



CORNELL  
UNIVERSITY  
LIBRARY



CORNELL UNIVERSITY LIBRARY



3 1924 063 472 835

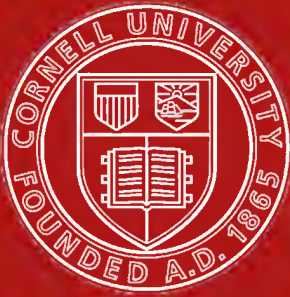

# Cornell University Library

The original of this book is in  
the Cornell University Library.

There are no known copyright restrictions in  
the United States on the use of the text.

<http://www.archive.org/details/cu31924063472835>





THE INTERNATIONAL STANDARD  
BIBLE ENCYCLOPAEDIA





THE  
INTERNATIONAL STANDARD  
BIBLE ENCYCLOPAEDIA

---

JAMES ORR, M.A., D.D., GENERAL EDITOR

JOHN L. NUELSEN, D.D., LL.D.

EDGAR Y. MULLINS, D.D., LL.D.

ASSISTANT EDITORS

MORRIS O. EVANS, D.D., PH.D., MANAGING EDITOR

---

VOLUME V  
SOCKET—ZUZIM  
INDEXES

---

CHICAGO  
THE HOWARD-SEVERANCE COMPANY

1915

5



COPYRIGHT, 1915, BY  
THE HOWARD-SEVERANCE COMPANY  
All Rights of Translation and  
Reproduction Reserved

---

International Copyright Secured

The Publishers supply this Encyclopaedia only through  
authorized sales-agents. Booksellers cannot obtain it.

Printed by The Lakeside Press  
Types cast and set by the University of Chicago Press  
Chicago, Illinois, U.S.A.

**SOCKET**, sok'et (סֹכֶת, 'edhen): The tabernacle in the wilderness being constructed as a portable building without permanent foundation, its stability was attained by the use of "sockets" into which the pillars and boards forming its walls were sunk. The word therefore is used solely in relation to the tabernacle, except in one poetic passage (Cant 5 15), where the legs of the beloved are compared to "pillars of marble set upon sockets of fine gold." In all, the tabernacle with its court rested upon 165 bases or sockets, apportioned thus: (1) silver sockets, each a talent (c 95 lbs.) in weight (Ex 38 27), viz. 96 to support the 48 boards of the tabernacle (Ex 26 19 ff); 4 for the pillars supporting the veil (ver 32)=100; (2) bronze sockets, weight not given, viz. 50 to support the 50 standards on which were hung the curtains of the tabernacle on N., S. and W. (27 10 ff), 10 to support 10 pillars on the E. (vs 13 ff), and 5 to support the 5 pillars upholding the screen at the tabernacle entrance (26 27)=65. The site for the tabernacle being chosen and leveled, these sockets would be "laid" upon it (Ex 40 18), and the tenons of the boards, or projecting base of the pillar, inserted into holes made for the purpose. W. SHAW CALDECOTT

**SOCOH**, sō'kō (שׁוֹכֹה, שׁוֹכֹה, sōkhōh, "branches"), **SOCO** (שׁוֹכֹה, sōkhō [in Ch only]; Σωχώ, Sōchō, most usual, but many forms in LXX and in AV: Socoh, Shochoh, Shoco, Shocho):

(1) A city in the Shephelah of Judah mentioned along with Jarmuth, Adullam, Azekah, etc (Josh 15 35); the Philis "gathered together at Socoh, which belongeth to Judah, and encamped between Socoh and Azekah" (1 S 17 1); it is mentioned as one of the districts from which Solomon drew his supplies (1 K 4 10, AV "Sochoh"); the association of Socoh in this verse with Hopher is worth noticing in connection with 1 Ch 4 18 ("Heber"). Soco (AV "Shoco") was one of the cities fortified by Rehoboam for the defence of Judah (2 Ch 11 7); it was captured by the Philis in the time of Ahaz (28 18). The site is, without doubt, *Kh. esh Shuweikeh* (*Shuweikeh* is a diminutive of *Shaukeh*, "a thorn"), a rounded, elongated hilltop, showing clear traces of ancient city walls. The situation is one of considerable natural strength on the south side of the Vale of Elah just where the *Wady es Sar* makes a sweep to the W. and becomes the *Wady es Sunt*. Like so many such ancient sites, the hill has very steep slopes on 3 sides (S., W., and N.), and is isolated from the ridge of higher ground to the E. by a narrow neck of lower ground. In the valley to the S.W. is a plentiful spring. The site was known to Jerome in the 4th cent. He described it as 8 or 9 Rom miles from Eleutheropolis (*Beit Jibrin*) (*PEF*, III, 53, 125, Sh XVII, *BR*, II, 21). The *Sucathites* (1 Ch 2 55) were probably inhabitants of Soco.

(2) A city of Judah in the S., associated (Josh 15 48) with Shamir and Jatir. This is doubtless *Kh. Shuweikeh*, a large ruin occupying a low hill, 10 miles S.W. of Hebron; there are many caves and rock-cut cisterns as well as drafted stones. Cheyne doubtfully locates the Socoh of 1 K 4 10 here. See *PEF*, 404, 410, Sh XXV; *BR*, I, 494.

E. W. G. MASTERMAN

**SOD, SODDEN**, sod'n. See SEETHE.

**SODA**, sō'da. See NITRE.

**SODERING**, sod'er-ing (סֹדֵרִי, *debhek*): AV in Isa 41 7, RV "soldering," of smith work.

**SODI**, sō'di (סֹדִי, *sōdhi*): One of the spies, representing the tribe of Zebulun (Nu 13 10).

**SODOM**, sod'um (סֹדֹם, *s'dhōm*; Σόδομα, *Sódoma*): One of the 5 CITIES OF THE PLAIN (q.v.), destroyed by fire from heaven in the time of Abraham and Lot (Gen 19 24). The wickedness of the city became proverbial. The sin of sodomy was an offence against nature frequently connected with idolatrous practices (see Rawlinson, *History of Phoenicia*). See SODOMITE. The fate of Sodom and Gomorrah is used as a warning to those who reject the gospel (Mt 10 15; 11 24; 2 Pet 2 6; Jude ver 7). The word is used in a typical sense in Rev 11 8. Sodom was probably located in a plain S. of the Dead Sea, now covered with water. The name is still preserved in *Jebel Usdum* (Mt. Sodom). See ARABAH; CITIES OF THE PLAIN; DEAD SEA.

LITERATURE.—Dillmann, *Genesis*, 111 f; Robinson, *BR*, II, 187 ff; G. A. Smith, *HGHL*, 505 ff; Blanckenhorn, *ZDPV*, XIX, 1896, 53 ff; Baedeker-Socin, *Pal*, 143; Buhl, *GAP*, II, 271, 274.

GEORGE FREDERICK WRIGHT

**SODOM, VINE OF** (סֹדֹם־גֵּפֶן, *gephen s'dhōm*):

"For their vine is of the vine of Sodom,  
And of the fields of Gomorrah:  
Their grapes are grapes of gall,  
Their clusters are bitter" (Dt 32 32).

This must be distinguished from the "Apples of Sodom" (q.v.), described by Jos (*BJ*, IV, viii, 4), which appear to have been an actual species of fruit, probably either the colocynth or the fruit of the Usher tree, *Calotropis procera*. It would appear, however, from the above, the only passage referring to the Vine of Sodom, that this expression is metaphorical and does not refer to any particular plant.

E. W. G. MASTERMAN

**SODOMITE**, sod'om-it (סֹדֹמִי, *s'dhēmī*, fem. סֹדֹמִיָּה, *s'dhēmīyāh*): *Kādēshēh* denotes properly a male temple prostitute, one of the class attached to certain sanctuaries of heathen deities, and "consecrated" to the impure rites of their worship. Such gross and degrading practices in Jeh's land could only be construed as a flagrant outrage; and any association of these with His pure worship was abhorrent (Dt 23 17f). The presence of Sodomites is noted as a mark of degeneracy in Rehoboam's time (1 K 14 24). Asa endeavored to get rid of them (15 12), and Jehoshaphat routed them out (22 46). Subsequent corruptions opened the way for their return, and Josiah had to break down their houses which were actually "in the house of the Lord" (2 K 23 7). The fem. *kādēshēh* is tr'd "prostitute" in Gen 38 21, 22; Hos 4 14; in Dt 23 17 "prostitute" (AVm "sodomitess," RVm transliterates). The Eng. word is, of course, derived from Sodom, the inhabitants of which were in evil repute for unnatural vice. W. EWING

**SODOMITISH**, sod'om-it-ish, **SEA**. See DEAD SEA.

**SODOMY**, sod'o-mi. See SODOM; SODOMITE; CRIMES; PUNISHMENTS.

**SOJOURNER**, soj'er-nēr, sō'jūr-nēr, suj'er-nēr. See STRANGER AND SOJOURNER.

**SOLDERING**, sod'er-ing. See SODERING.

**SOLDIER**, sōl'jēr. See ARMY.

**SOLEMN**, sol'em, **SOLEMNITY**, sō-lem'ni-ti: The word "solemn" had (1) at first the meaning "once in the year," through its derivation from Lat *sollus*, "whole," *annus*, "year." As, however, a regular annual occurrence is usually one of particular importance, the word took on (2) the mean-

ing "ceremonious." From this is derived (3) the usual modern force of "grave" in opposition to "joyous." This last meaning is not in Bib. Eng., and the meanings of "solemn" in EV are either (1) or (2). Nor is there any certain case of (1), for the word is always a gloss in EV and, although frequently introduced in references to annual events (Lev 23 36, etc), it is even more often used where "annual" is foreign to the passage (2 K 10 20; Ps 92 3, etc). The use of the word in AV is unsystematic. It is always (except in Jer 9 2) found in conjunction with "assembly" when (10 t) the latter word represents *'āṣārāh* (*'āṣeret*) (Lev 23 36, etc) (retained by RV with m "closing festival," Lev 23 36; 2 Ch 7 9; Neh 8 18). AV uses "solemnity" or "solemn day," "feast," etc, 17 t for the very common word *mō'ēdh* ("appointed" time, etc; see FEAST).

RV's treatment of these passages defies analysis. "Solemnity" is kept in Isa 33 20; Ezk 46 11, and "solemn" in Lam (4 t); Hos (3 t); Zeph 3 18. In Ezk 36 38; 45 17; 46 9 it is replaced by "appointed," elsewhere (and for *mō'ādāh*, 2 Ch 8 13) by "set." The margins further complicate the renderings. AV also uses "solemn" with *hagh*, "feast," 4 t, and with *hāghagh*, "keep a feast," in Dt 16 15. The word is dropped by RV, except ERV in Ps 81 3. Finally, AV and RV have "solemn sound" for *higgāyōn*, in Ps 92 3. The context, however, demands "resounding melody." And 11 t RV has introduced "solemn" to represent the intensive in the form *shabbath shabbāhōn* (Ex 16 23, etc), where AV has simply "sabbath" or "sabbath of rest." RV here has imitated the adverbial "solemnly" in the similar intensified expressions in Gen 43 3; 1 S 8 9.

RV Apoc translates *en hēmēraīs kairōi*, "in the days of the season" (Bar 1 14), by "on the days of the solemn assembly" (AV "solemn days"), and both AV and RV have "solemn feast days" for *dies festos* (2 Esd 1 31). Otherwise AV's use of "solemn" is dropped by RV. BURTON SCOTT EASTON

**SOLEMN ASSEMBLY (MEETING)** See CONGREGATION; FASTS AND FEASTS; SOLEMN, SOLEMNITY.

**SOLOMON**, sol'ō-mun (רַמְלֶכֶת, *shelōmōh*; NT Σολομών, *Solomōn*):

- I. EARLY LIFE
  1. Name and Meaning
  2. Sources
  3. Birth and Upbringing
  4. His Accession
  5. Closing Days of David
- II. REIGN OF SOLOMON
  1. His Vision
  2. His Policy
  3. Its Results
  4. Alliance with Tyre
  5. Alliance with Egypt
  6. Domestic Troubles
- III. HIS BUILDINGS
  1. The Temple
  2. The Palace
  3. Other Buildings
  4. The *Corbē*
- IV. HIS CHARACTER
  1. Personal Qualities
  2. His Wisdom
  3. His Learning
  4. Trade and Commerce
  5. Officers of State
  6. Wives
  7. Revenues
  8. Literary Works

#### LITERATURE

**I. Early Life.**—Solomon was the son of David and Bath-sheba, and became the 3d king of Israel. He was so named by his mother (2 S 12 24, K<sup>r</sup>ē; see TEXT), but by the prophet and Mean- ing Nathan, or by his father (Vulg), he was called Jedidiah—"loved of Jeh." The name "Solomon" is derived from the root meaning "to be quiet" or "peaceful," and S. was certainly the least warlike of all the kings of Israel or Judah, and in that respect a remarkable contrast to his father (so 1 Ch 22 9). His name

in Heb compares with Irenaeus in Gr, Friedrich in Ger., and Selim in Arab.; but it has been suggested that the name should be pronounced *shillūmāh*, from the word denoting "compensation," Bath-sheba's second son being given in compensation for the loss of the first (but see 3, below).

The oldest sources for the biography of S. are doubtless the "Annals of Solomon" referred to in 1 K 11 41, the "history of Nathan the prophet," the "prophecy of Ahijah the Shilonite" and the "visions of Iddo the seer," mentioned in 2 Ch 9 29, all which may be merely the relative sections of the great book of the "Annals of the Kings" from which our Books of K and Ch are both derived. These ancient works are, of course, lost to us save in so far as they have been embodied in the OT narrative. There the life of S. is contained in 2 S 12 24 f; 1 K 1-11; 1 Ch 22-2 Ch 9. Of these sources 2 S 12 24 f and 1 K 1, 2 are much the oldest and in fact form part of one document, 2 S 9-20; 1 K 1, 2 dealing with the domestic affairs of David, which may well be contemporary with the events it describes. The date of the composition of the Books of Ch is about 300 BC—700 years after the time of S.—and the date of the Books of K, as a completed work, must, of course, be later than the exile. Nothing of importance is gained from citations from early historians in Jos and later writers. Far and away the best source for, at least, the inner life of S. would be the writings ascribed to him in the OT, could we be sure that these were genuine (see below).

The children of David by Bath-sheba are given in 1 Ch 3 5 as Shimea, Shobab, Nathan and Solomon.

Cf also 2 S 5 14; 1 Ch 14 4, where the same persons evidently are named. It would thus appear that S. was the 4th son of Bath-sheba, supposing Shimea to be the child that died. Otherwise S. would be the 5th son. There are therefore some events omitted in 2 S 12 24 f, or else the names Shobab and Nathan are remains of some clause which has been lost, and not proper names. Like the heir apparent of a Turkish sultan, S. seems to have spent his best years in the seclusion of the harem. There he was doubtless more influenced by his mother than by his father, and in close intimacy with his mother was the prophet Nathan, who had given him his by-name of fortunate import (2 S 12 25).

It was not until David lay on his deathbed that S. left the women's quarters and made his appearance in public. That he had been selected by David, as the son of the favorite wife, to succeed him, is presupposed in the instructions which he received from his father regarding the building of the Temple. But as soon as it appeared that the life of David was nearing its end, it became evident that S. was not to have a "walk over." He found a rival in Adonijah the son of Haggith, who was apparently the eldest surviving son of his father, and who had the support of Joab, by far the strongest man of all, of Abiathar, the leading, if not the favorite, priest (cf 2 S 15 24 ff), and of the princes of the royal house. S., on the other hand, had the support of his mother Bath-sheba, David's favorite wife, of Nathan the court prophet, of Zadok who had eclipsed Abiathar, of Benaiah, the son of a priest, but one of the three bravest of David's soldiers, and captain of the bodyguard of Cherethites and Pelethites, and of the principal soldiers. It is esp. noted that Shimei and Hushai (so Jos) took no active part at any rate with Adonijah (1 K 1 8). The conspiracy came to nothing, for, before it developed, S. was anointed at Gibeon (not Gihon, 1 K 1 33.38.45), and entered Jerus as king.

The age of S. at his accession is unknown. The expression in 1 K 3 7 is not, of course, to be taken literally (otherwise *Ant*, VIII, vii, 8).

**5. Closing Days of David** His reign opened, like that of many an oriental monarch, with a settlement in blood of the accounts of the previous reign. Joab, David's nephew, who had brought the house within the bounds of blood revenge, was executed. Adonijah, as soon as his father had breathed his last, was on a nominal charge put to death. Abiathar was relegated to his home at Anathoth (1 K 2 26). Conditions were imposed on Shimei which he failed to keep and so forfeited his life (2 36 ff). These steps having been taken, S. began his reign, as it were, with a clean slate.

**II. Reign of Solomon.**—It was apparently at the very beginning of his reign that S. made his famous choice of a "hearing heart," i.e. an obedient heart, in preference to riches or long life. The vision took place at Gibeon (2 Ch 1 7, but in 1 K 3 4 f the ancient versions read "upon the altar that was in Gibeon. And the Lord appeared," etc). The life of S. was a curious commentary on his early resolution. One of the first acts of his reign was apparently, in the style of the true oriental monarch, to build himself a new palace, that of his father being inadequate for his requirements. In regard to politics, however, the events of Solomon's reign may be regarded as an endorsement of his choice. Under him alone was the kingdom of Israel a great world-power, fit almost to rank beside Assyria and Egypt. Never again were the bounds of Israel so wide; never again were north and south united in one great nation. There is no doubt that the credit of this result is due to the wisdom of S.

S. was by nature an unwarlike person, and his whole policy was in the direction of peace. He disbanded the above-mentioned foreign legion, the Cherethites and Pelethites, who had done such good service as bodyguard to his father. All his officers seem to have been mediocre persons who would not be likely to force his hand, as Joab had done that of David (2 S 3 39). Even the fortification of Jerus and of the frontier towns was undertaken with a view to repel attack, not for the purposes of offence. S. did, no doubt, strengthen the army, esp. the cavalry arm (1 K 4 26; 10 26), but he never made any use of this, and perhaps it existed largely on paper. At any rate S. seems to have been rather a breeder of and dealer in horse-flesh than a soldier. He appears also to have had a fine collection of armor (10 25), but much of it was made of gold (10 16 f) and was intended for show, not for use. Both in his reputation for wisdom and in his aversion to war S. bears a striking resemblance to King James VI of Scotland and I of England, as depicted by the hand of Sir Walter Scott. It was fortunate for him that both the neighboring great powers were for the time in a decadent state, otherwise the history of the kingdom of Israel would have ended almost before it had begun. On the other hand, it has been remarked that if S. had had anything like the military genius of David and his enthusiasm for the religion of Jeh, he might have extended the arms of Israel from the Nile to the Tigris and anticipated the advent of Islam. But his whole idea was to secure himself in peace, to amass wealth and indulge his love of grandeur with more than oriental splendor.

S., in fact, was living on the achievements and reputation of his father, who laid the basis of security and peace on which the commercial genius of S. could raise the magnificent structure which he did. But he took the clay from the foundations in

order to build the walls. The Hebrews were a military people and in that consisted their life. S. withdrew their energies from their natural bent and turned them to commerce, for which they were not yet ripe. Their soul rebelled under the irksome drudgery of an industry of which they did not reap the fruits. S. had in fact reduced a free people to slavery, and concentrated the wealth of the whole country in the capital. As soon as he was out of the way, his country subjects threw off the yoke and laid claim to their ancient freedom. His son found himself left with the city and a territory as small as an English county.

Solomon's chief ally was Hiram, the king of Tyre, probably the friend and ally of David, who is to be distinguished from Hiram the artificer of 1 K 7 13 ff. Hiram the king entered into a treaty with S. which was to the advantage of both parties.

**4. Alliance with Tyre** Hiram supplied S. with cedar and pine wood from Lebanon, as well as with skilled artisans for his building. Tyrian sailors were also drafted into the ships of S., the Hebrews not being used to the sea (1 K 9 26 f), besides which Phoen ships sailed along with those of S. The advantages which Hiram received in return were that the Red Sea was open to his merchantmen, and he also received large supplies of corn and oil from the land of Israel (1 K 5 11 corrected by LXX and 2 Ch 2 10). At the conclusion of the building of the palace and Temple, which occupied 20 years, S. presented Hiram with 20 villages (1 K 9 11; the converse, 2 Ch 8 2), and Hiram made S. a return present of gold (1 K 9 14; omitted in 2 Ch).

Second to Hiram was the Pharaoh of Egypt, whose daughter S. married, receiving as her dowry the town of Gezer (1 K 9 16). This **5. Alliance with Egypt** This alliance with Egypt led to the introduction of horses into Israel (10 28 f), though David had already made a beginning on a small scale (2 S 8 4). Both these alliances lasted throughout the reign. There is no mention of an alliance with the eastern power, which was then in a decadent state.

It was probably nearer the beginning than the end of Solomon's reign that political trouble broke out within the realm. When David had **6. Domestic Troubles** annexed the territory of the Edomites at the cost of the butchery of the male population (cf 2 S 8 14; Ps 60, title) one of the young princes of the reigning house effected his escape, and sought and found an asylum in Egypt, where he rose to occupy a high station. No sooner had he heard of the death of David and Joab than he returned to his native country and there stirred up disaffections against S. (1 K 11 14 ff; see HADAD), without, however, restoring independence to Edom (1 K 9 26). A second occasion of disaffection arose through a prophet having foretold that the successor of S. would have one of the Israelite tribes only and that the other ten clans would be under Solomon's master of works whom he had set over them. This officer also took refuge in Egypt and was protected by Shishak. He remained there until the death of S. (1 K 11 26 ff). A third adversary was Rezon who had fled from his master the king of Zobah (1 K 11 23), and who established himself at Damascus and founded a dynasty which was long a thorn in the side of Israel. These domestic troubles are regarded as a consequence of the falling away of S. from the path of rectitude, but this seems to be but a kind of anticipative consequence, that is, if it was not till the end of his reign that S. fell into idolatry and polytheism (1 K 11 4).

**III. His Buildings.**—The great undertaking of the reign of S. was, of course, THE TEMPLE (q.v.), which was at first probably considered as the Chapel Royal and an adjunct of the palace. The Temple was begun in the 4th year of the reign and finished in the 11th, the work of the building occupying 7½ years (1 K 6; 7 13 ff). The delay in beginning is remarkable, if the material were all ready to hand (1 Ch 22). Worship there was inaugurated with fitting ceremony and prayers (1 K 8).

To S., however, his own palace was perhaps a more interesting undertaking. It at any rate occupied more time, in fact 13 years (1 K 7

**1. The Temple** 1-12; 9 10; 2 Ch 8 1), the time of building both palace and Temple being 20 years. Possibly the building

of the palace occupied the first four years of the reign and was then intermitted and resumed after the completion of the Temple; but of this there is no indication in the text. It was called the House of the Forest of Lebanon, from the fact that it was lined with cedar wood (1 K 7 2). A description of it is given in 1 K 7 1-12.

S. also rebuilt the wall of the city and the citadel (see JERUSALEM; MILLO). He likewise erected castles at the vulnerable points of the

**3. Other Buildings** frontiers—Hazor, Megiddo and Gezer (1 K 9 15), lower Beth-horon and BAALATH (q.v.). According to the K<sup>erē</sup> of 1 K 9 18 and the ancient VSS as well as 2 Ch 8 4, he was the founder of Tadmor (Palmyra); but the K<sup>ethibh</sup> of 1 K 9 18 reads Tamar (cf Ezk 47 19). Some of the remains of buildings recently discovered at Megiddo and Gezer may go back to the time of S.

S. could not have built on the scale he did with the resources ordinarily at the command of a free ruler.

**4. The Corvée** Accordingly we find that one of the institutions fostered by him was the *corvée*, or forced labor. No doubt something of the kind always had existed (Josh 9 21) and still exists in all despotic governments. Thus the people of a village will be called on to repair the neighboring roads, esp. when the Pasha is making a progress in the neighborhood. But S. made the thing permanent and national (1 K 5 13-15; 9 15). The immediate purpose of the levy was to supply laborers for work in the Lebanon in connection with his building operations. Thus 30,000 men were raised and drafted, 10,000 at a time, to the Lebanon, where they remained for a month, thus having two months out of every three at home. But even when the immediate cause had ceased, the practice once introduced was kept up, and it became one of the chief grievances which led to the dismemberment of the kingdom (1 K 12 18, Adoram=Adoniram; cf 2 S 20 24), for hitherto the *corvée* had been confined to foreign slaves taken in war (1 K 9 21). It is said the higher posts were reserved for Israelites, the laborers being foreigners (9 22), that is, the Israelites acted as foremen. Some of the foreign slaves seem to have formed a guild in connection with the Temple which lasted down to the time of the exile (Ezr 2 55-57; Neh 7 57-59; see NETHINIM).

**IV. His Character.**—In S. we have the type of a Turkish sultan, rather than a king of Israel. The Heb kings, whether of Israel or

**1. Personal Qualities** Judah, were, in theory at least, elective monarchs like the kings of Poland.

If one happened to be a strong ruler, he managed to establish his family, it might be, for three or even four generations. In the case of the Judæan dynasty the personality of the first king made such a deep impression upon the heart of the people that the question of a change of dynasty

there never became pressing. But S. would probably have usurped the crown if he had not inherited it, and once on the throne he became a thorough-going despot. All political power was taken out of the hands of the sheiks, although outward respect was still paid to them (1 K 8 1), and placed in the hands of officers who were simply creatures of S. The resources of the nation were expended, not on works of public utility, but on the personal aggrandizement of the monarch (1 K 10 18 ff). In the means he took to gratify his passions he showed himself to be little better than a savage, and if he did not commit such great crimes as David, it was perhaps because he had no occasion, or because he employed greater cunning in working out his ends.

The wisdom for which S. is so celebrated was not of a very high order; it was nothing more than practical shrewdness, or knowledge of

**2. Wisdom** the world and of human nature. The

common example of it is that given in 1 K 3 16 ff, to which there are innumerable parallels in Indian, Gr and other literatures. The same worldly wisdom lies at the back of the Book of Prov, and there is no reason why a collection of these should not have been made by S., just as it is more likely that he was a composer of verses than that he was not (1 K 4 32). The statement that he had breadth of heart (4 29) indicates that there was nothing known which did not come within his ken.

The word "wisdom," however, is used also in another connection, namely, in the sense of theoretical knowledge or book learning,

**3. Learning** esp. in the department of natural history. It is not to be supposed that S. had any scientific knowledge of botany or zoölogy, but he may have collected the facts of observation, a task in which the Oriental, who cannot generalize, excels. The wisdom and understanding (1 K 4 29) for which S. was famous would consist largely in stories about beasts and trees like the well-known *Fables of Pilpai*. They included also the "wisdom" for which Egypt was famous (4 30), that is, occult science. It results from this last statement that S. appears in post-Bib. and Arabian lit. as a magician.

S. was very literally a merchant prince. He not only encouraged and protected commerce, but engaged in it himself. He was in fact

**4. Trade and Commerce** the predominant, if not sole, partner in a great trading concern, which was nothing less than the Israelite nation.

One of his enterprises was the horse trade with Egypt. His agents bought up horses which were again sold to the kings of the Hittites and the Aramaeans. The prices paid are mentioned (1 K 10 29). The best of these S. no doubt retained for his own cavalry (1 K 10 26). Another commodity imported from that country was linen yarn (1 K 10 28 AV). The navy which S. built at the head of the Gulf of Akaba was not at all for military, but purely commercial ends. They were ships of Tarshish, that is, merchant ships, not ships sailing to Tarshish, as 2 Ch 9 21. They traded to OPHIR (q.v.), from which they brought gold, silver, ivory, apes and peacocks, the round voyage lasting 3 years (1 K 9 26 ff; 10 22). Special mention is made of "almug" (10 11) or "algum" (2 Ch 9 10 f) trees (q.v.). The visit of the Queen of Sheba would point to the overland caravan routes from the Yemen being then open (1 K 10 15). What with direct imports and the result of sales, silver and cedar wood became very plentiful in the capital (10 27).

The list of Solomon's officers of state is given in 1 K 4 2 ff. These included a priest, two secretaries, a recorder, a commander-in-chief, a chief commissariat officer, a chief shepherd (if we may read

*rō'eh* for *rē'eh*), a master of the household, and the head of the *corée*. The list should be compared with those of David's officers (2 S 8 5. Officers 16 ff; 20 23 ff). There is much resemblance, but we can see that the machine of state was becoming more complicated. The bodyguard of foreign mercenaries was abolished and the captain Benaiah promoted to be commander-in-chief. Two scribes were required instead of one. Twelve commissariat officers were appointed whose duty it was to forward from their districts the supplies for the royal household and stables. The list of these officials, a very curious one, is given in 1 K 4 7 ff. It is to be noted that the 12 districts into which the country was divided did not coincide with the territories of the 12 tribes. It may be remarked that S. seems as far as possible to have retained the old servants of his father. It will be noticed also that in all the lists there is mention of more than one priest. These "priests" retained some of their original functions, since they acted as prognosticators and diviners.

Solomon's principal wife was naturally the daughter of Pharaoh; it was for her that his palace was built (1 K 3 1; 7 8; 9 16.24).

**6. Wives** But in addition to her he established marriage relations with the neighboring peoples. In some cases the object was no doubt to cement an alliance, as with the Zidonians and Hittites and the other nationalities (11 1), some of which were forbidden to Israelites (Dt 7 3). It may be that the daughter of Pharaoh was childless or died a considerable time before S., but his favorite wife was latterly a granddaughter of Nahash, the Ammonite king (1 K 14 21 LXX), and it was her son who succeeded to the throne. Many of S.'s wives were no doubt daughters of wealthy or powerful citizens who wished by an alliance with the king to strengthen their own positions. Yet we do not read of his marrying an Israelite wife. According to the Arabian story Bilkis, the Queen of Sheba who visited S. (1 K 10 1 ff), was also married to him. He appears to have had only one son; we are not told of any other than Rehoboam. His daughters were married to his own officers (1 K 4 11.15).

S. is said to have started his reign with a capital sum of 100,000 talents of gold and a million talents of silver, a sum greater than the national debt of Great Britain. Even so, this huge sum was ear-marked for the building of the Temple (1 Ch 22 14). His income was, for one year, at any rate, 666 talents of gold (1 K 10 14), or about twenty million dollars. This seems an immense sum, but it probably was not so much as it looks. The great mass of the people were too poor to have any commodities which they could exchange for gold. Its principal use was for the decoration of buildings. Its purchasing power was probably small, because so few could afford to buy it. It was in the same category as the precious stones which are of great rarity, but which are of no value unless there is a demand for them. In the time of S. there was no useful purpose to which gold could be put in preference to any other metal.

It is not easy to believe that the age of S., so glorious in other respects, had not a literature to correspond. Yet the reign of the sultan Ismail in Morocco, whom S. much resembles, might be cited in favor of such a supposition. S. himself is stated to have composed 3,000 animal stories and 1,005 songs (1 K 4 32). In the OT the following are ascribed to him: three collections of Proverbs, 1 1 ff; 10 1 ff; 25 1 ff; The Song of

Songs; Pss 72 and 127; Eccl (although S. is not named). In Prov 25 1 the men of Hezekiah are said to have copied out the following proverbs.

LITERATURE.—The relative portions of the histories by Ewald, Stanley (who follows Ewald), Renan, Wellhausen and Kittel; also H. Winckler, *Alttestamentliche Untersuchungen*; and the comms. on the Books of K and Ch.

THOMAS HUNTER WEIR  
SOLOMON, ODES OF. See APOCALYPTIC LITERATURE, B, III, 2.

SOLOMON, POOLS OF. See POOLS OF SOLOMON.

SOLOMON, PSALMS (PSALTER) OF. See APOCALYPTIC LITERATURE, B, III, 1.

SOLOMON, SONG OF. See SONG OF SONGS.

SOLOMON, WISDOM OF. See WISDOM OF SOLOMON.

SOLOMON'S PORCH. See PORCH, SOLOMON'S.

SOLOMON'S SERVANTS (עֲבָדֵי שְׁלֹמֹה, 'abh'dhē sh'ōmōh; δοῦλοι Σαλωμών, *douloi Salōmōn*): "The children of Solomon's servants" constituted a company or guild of the Jewish exiles who returned with Zerubbabel from Babylonia to Jerus in 537 BC, pursuant to the decree of Cyrus; they are mentioned 5 t (Ezr 2 55.58|Neh 7 57.60; Neh 11 3). As the prime purpose of the returning exiles was the rebuilding of the Temple and the restoration of Jeh's worship (Ezr 1 2.3), it was important that those who held the privileges of sanctuary service as a family heritage should go back to their duties. This included, besides priests and Levites, the NETHINIM (q.v.) and Solomon's Servants. In every reference to them, Solomon's Servants are connected with the Nethinim, who had been "given" or dedicated (*nethinim* or *nethūnim* is pass. participle of *nāthan*, "to give," "to appoint") by David "for the service of the Levites" (Ezr 8 20); so Solomon's Servants traced their official beginning back to Solomon's appointment, as their name indicates. In the joint references they always fall into the natural chronological order, i.e. following the Nethinim. It is possible, therefore, that they are referred to in Ezr 7 24 also, under the title "servants of this house of God," which immediately follows "Nethinim" in the list of those exempt from taxation and tolls.

What their duties in the house of God may have been is not stated in the records. These must have been more or less menial, the more formal and honorable duties being reserved for "the priests and Levites, the singers, [and] porters" (Ezr 7 24). When the ark was brought to Jerus by David and the ceremonial of the sacrificial system was more strictly observed, the services of priests and Levites were greatly increased, and to meet the needs of the new order David appointed the Nethinim (Ezr 8 20; cf 1 Ch 9 2). Likewise the much greater increase in such duties on the completion of Solomon's Temple was the occasion for the dedication of an additional number of these assistants to the Levites.

The number of those who returned with Zerubbabel was not great, together with the Nethinim being only 392. This does not appear to have been sufficient for the needs of the sanctuary, since Ezra, in preparation for his expedition in 458 BC, made special appeal for Nethinim to go with him, of whom 220 responded (Ezr 8 15-20). No doubt at the first their service was considered to be lowly; but by the time of the exile, certainly after it, their position had developed into one of considerable honor and constituted them a privileged class in the nation. While many of the people were required by Nehemiah to live in Jerus, they were allowed to dwell in their possessions "in the cities of Judah" (Neh 11 3).

A question of some interest and of difference of opinion is whether Solomon's Servants were Levites or non-Israelites. The latter view is the more generally held, for the following reasons:

(1) After the completion of the Temple and his other great buildings a large body of workmen, whom Solomon had drafted from the non-Israelite population, were without occupation, and might well have been assigned to the menial duties of the Temple (1 K 9), their name in LXX (*douloi*) properly indicating such a class; (2) Ezekiel excludes non-Israelites from the service of his ideal temple, as though they had been allowed in the preëxilic Temple (44 9); (3) they are always clearly distinguished from the Levites in the lists of religious bodies.

But, on the other hand, equally strong arguments favor their Levitical descent: (1) Levites also are called *douloi* in 1 Esd; (2) it is more probable that Ezekiel refers to the abuses of Athaliah, Ahaz and Manasseh than to the institutions of David and Solomon; (3) Ezra specifically classifies the Nethinim as Levites (8 15-20); (4) there is not the slightest intimation in the text of 1 K 9 15-22 that the gentile bondservants were assigned to temple-service after completion of the great building operations; such an interpretation is wholly inferential, while, on the contrary, it is more probable that such an innovation would have been mentioned in the narrative; and (5) it is not probable that Ezra and Nehemiah, or Zerubbabel, with their strict views of Israelitish privilege (cf Ezr 2 62), would have admitted non-Israelites to sacred functions, the less so in view of Ezekiel's prohibition. There is more ground, then, for holding that Solomon's Servants, like the porters and singers, were an order of Levites. EDWARD MACK

**SOMEIS**, sō'mē-is (Σομεῖς, *Someeís*; AV Samis): One of the Israelites who put away their foreign wives (1 Esd 9 34) = "Shimei" in Ezr 10 38.

**SOMETIME**, sum'tim: In modern Eng. means "occasionally," and is so used in Sir 37 14 for *évtore*, *entote*. Otherwise the word means "at some past time," and is the tr of *πρότε*, *poté*. RV changes to "aforetime" in Wisd 5 3; 1 Pet 3 20; to "once" in Eph 2 13; 5 8; to "in time past" in Col 1 21; while in Col 3 7 ERV has "aforetime," ARV "once." AV does not distinguish between "sometime" and "sometimes."

**SON**, sun, **SONS**, sunz: (1) In Bib. language the word "son" is used first of all in its strictly literal sense of male issue or offspring of a man or woman. In a few cases in the OT, as in Gen 3 16; Josh 17 2; Jer 20 15, the Heb word *bēn*, is tr<sup>d</sup> correctly in the Eng. by the word "child" or "children," as it includes both sexes, as in Gen 3 16, or is limited to males by the use of the modifying term "male." Closely connected with this meaning of direct male issue or of children is its use to denote descendants, posterity in the more general sense. This usage which, as in the case of the sons (children) of Israel, may be regarded perhaps as originating in the conception of direct descent from the common ancestor Israel, came in the course of time to be a mere ethnographic designation, so that the term "the children of Israel" and "the children of Ammon" meant no more than Israelites or Ammonites, that is, inhabitants of the lands of Israel or Ammon respectively. An extension of this usage is to be found in the designation of a people as the sons or children of a land or city; so in Am 9 7 "children of the Ethiopians," or Ezk 16 23, where the literal rendering would be "sons of Asshur," instead of the Assyrians, and "the children of Jerus" in Joel 3 6. See BAR (prefix); BEN-

(2) More characteristic of Bib. usage is the employment of the word "son" to indicate membership in a class or guild, as in the common phrase

"sons of the prophets," which implies nothing whatever as to the ancestry, but states that the individuals concerned are members of the prophetic guilds or schools. In the NT the word "sons" (*huiōi*) in Lk 11 19, rendered "children" in Mt 12 27 AV, means, not physical descendants, but members of the class or sect; according to Mt the Pharisees, who were attacking Christ.

(3) The word "son" is used with a following genitive of quality to indicate some characteristic of the person or persons described. In the Eng. the word "son" is usually omitted and the phrase is paraphrased as in 2 S 3 34, where the words tr<sup>d</sup> "wicked men" in AV mean lit. sons or children of wickedness. Two examples of this usage may be cited: the familiar phrase "sons of Belial" in the OT (Dt 13 13 AV, and often), where the meaning is simply base or worthless fellows (cf Nu 24 17, m "children of Sheth" [*Expos T*, XIII, 64b]); and in the NT the phrase "sons of thunder," which is given in Mk 3 17 as the explanation of the epithet "Boanerges." This use is common in the NT, as the phrases "children of the kingdom," "children of light," etc., indicate, the general meaning being that the noun in the genitive following the word children indicates some quality of the persons under consideration. The special phrases "Son of man" and "Son of God" are considered in separate articles. See also RELATIONSHIPS, FAMILY.

WALTER R. BETTERIDGE

**SON-IN-LAW**. See RELATIONSHIPS, FAMILY.

**SON OF GOD**, THE (ὁ υἱὸς θεοῦ, *ho huiōs theou*):

1. Use of Title in the Synoptists
  2. Meanings in the OT
  3. Sense as Applied to Jesus
  4. Physical Reason
  5. Alleged Equivalence to "Messiah" (Baptism, Temptation, etc)—Personal Sense Implied
  6. Higher Use by Jesus Himself
  7. The "Son" in Mt 11 27
  8. In Mk 13 32
  9. In Mt 28 18-20
  10. Apostolic Doctrine: Deity Affirmed
  11. The Fourth Gospel: Deity, Preëxistence, etc
- LITERATURE

While the title "the Son of man" is always, except once, applied by Jesus to Himself, "the Son of God" is never applied by Jesus to Himself in the Synoptists. When, however, it is applied to Him by others, He accepts it in such a way as to assert His claim to it. Now and then He Himself employs the abbreviated form, "the Son," with the same intention; and He often speaks of God as "the Father" or "my Father" or "my Father who is in heaven" in such a manner as to betray the consciousness that He is the Son of God.

While to the common mind "the Son of man" is a title designating the human side of Our Lord's person, "the Son of God" seems as obviously to indicate the Divine side. But scholarship cannot take this for granted; and, indeed, it requires only a hasty glance at the facts to bring this

home even to the general reader, because in Scripture the title is bestowed on a variety of persons for a variety of reasons. First, it is applied to angels, as when in Job 2 1 it is said that "the sons of God came to present themselves before Jeh"; they may be so called because they are the creatures of God's hands or because, as spiritual beings, they resemble God, who is a spirit. Secondly, in Lk 3 38 it is applied to the first man; and from the parable of the Prodigal Son it may be argued that it is applicable to all men. Thirdly, it is applied to the Heb nation, as when, in Ex 4 22, Jeh says to Pharaoh, "Israel is my son, my first-born," the reason being that Israel was the object of Jeh's special love and



gracious choice. Fourthly, it is applied to the kings of Israel, as representatives of the chosen nation. Thus, in 2 S 7 14, Jeh says of Solomon, "I will be his father, and he shall be my son"; and, in Ps 2 7, the coronation of a king is announced in an oracle from heaven, which says, "Thou art my son; this day have I begotten thee." Finally, in the NT, the title is applied to all saints, as in Jn 1 12, "But as many as received him, to them gave he the right to become children of God, even to them that believe on his name." When the title has such a range of application, it is obvious that the Divinity of Christ cannot be inferred from the mere fact that it is applied to Him.

It is natural to assume that its use in application to Jesus is derived from one or other of its OT uses; and the one almost universally fixed upon by modern scholarship as Applied to Jesus that from which it was derived is the fourth mentioned above—that to the Jewish kings. Indeed, it is frequently asserted that in the Jewish lit. between the OT and the NT, it is found already coined as a title for the Messianic king; but the instances quoted by Dalman and others in proof of this are far from satisfactory.

When we come to examine its use in the NT as applied by others to Jesus, the facts are far from simple, and it is not applied in a uniform sense. In Lk 1 35, the following reason for its use is given, "The Holy Spirit shall come upon thee, and the power of the Most High shall overshadow thee: wherefore also the holy thing which is begotten shall be called the Son of God." This is a physical reason, akin to that on account of which the angels or the first man received the title; but it is rather curious that this point of view does not seem to be adopted elsewhere, unless it be in the exclamation of the centurion at the foot of the cross, "Truly this was the Son of God" (Mt 27 54). As a pagan this soldier might be thinking of Jesus as one of those heroes, born of human mothers but divine fathers, of whom the mythology of his country had so much to tell (cf m).

(1) *Baptism, Temptation.*—It has been contended, not without plausibility, that for Jesus Himself the source of the title may have been the employment of it in the Equivalence voice from heaven at His Baptism, to Messiah "This is my beloved Son, in whom I am well pleased" (Mt 3 17). By these words, it is usually assumed, He was designated as the Messiah; but in the adj. "beloved," and the words "in whom I am well pleased," there is something personal, beyond the merely official recognition. The same may be said of the voice from heaven in the scene of the Transfiguration. Milton, in *Paradise Regained*, makes Satan become aware of the voice from heaven at the Baptism; but this is also implied in the terms with which he approached Him in the Temptation in the wilderness, "If thou art the Son of God" (Mt 4 3, etc); and, if this was the sense in which the prince of devils made use of the phrase, we may conclude that in the mouths of the demoniacs who hailed Jesus by the same title it must have had the same meaning.

(2) *At Caesarea Philippi.*—When, at Caesarea Philippi, Jesus evoked from the Twelve their great confession, this is given by two of the synoptists in the simple form, "Thou art the Christ" (Mk 8 29; Lk 9 20); but Mt adds, "the Son of the living God" (Mt 16 16). It is frequently said that Hebrew parallelism compels us to regard these words as a mere equivalent for "Messiah." But this is not the nature of parallelism, which generally includes

in the second of the parallel terms something in excess of what is expressed in the first; it would be quite in accordance with the nature of parallelism if the second term supplied the reason for the first. That is to say, Jesus was the Messiah because He was the Son of God.

(3) *Trial before Sanhedrin.*—There is another passage where it is frequently contended that "the Christ" and "the Son of God" must be exactly parallel, but a close examination suggests the reverse. In the account of the ecclesiastical trial in the Gospel of Lk, He is charged, "If thou art the Christ, tell us"; and, when He replies, "If I tell you, ye will not believe: and if I ask you, ye will not answer. But from henceforth shall the Son of man be seated at the right hand of the power of God," they all say, "Art thou then the Son of God?" and, when He replies in the affirmative, they require no further witness (Lk 22 67-71), Matthew informing us that the high priest hereupon rent his garments, and they all agreed that He had spoken blasphemy and was worthy of death (Mt 26 65 f). The usual assumption is that the second question, "Art thou . . . the Son of God?" implies no more than the first, "Art thou the Christ?"; but is not the scene much more intelligible if the boldness of His answer to the first question suggested that He was making a still higher claim than to be the Christ, and that their second question applied to this? It was when Jesus affirmed this also that their angry astonishment knew no bounds, and their sentence was immediate and capital. It may be questioned whether it was blasphemy merely to claim to be the Messiah; but it was rank and undeniable blasphemy to claim to be the Son of God. This recalls the statement in Jn 5 18, "The Jews sought the more to kill him, because he not only brake the sabbath, but also called God his own Father, making himself equal with God"; to which may be added (Jn 10 33), "The Jews answered him, For a good work we stone thee not, but for blasphemy; and because that thou, being a man, makest thyself God."

Naturally it is with the words of Jesus Himself on this subject that we are most concerned. He speaks of God as His Father, and to the disciples He speaks of God as their Father; but He never speaks to them of God as their common Father: what He says is, "My Father and your Father" (Jn 20 17). H. J. Holtzmann and others have attempted to make light of this, and even to speak of the opening words of the Lord's Prayer, "Our Father who art in heaven," as if Jesus might have uttered them in company with the disciples; but the distinction is a vital one, and we do not agree with those who can believe that Jesus could have uttered, for Himself along with others, the whole of the Lord's Prayer, including the petition, "Forgive us our debts, as we also have forgiven our debtors."

Of the passages in the Synoptists where Jesus speaks about God as "the Father" and Himself as "the Son," a peculiar solemnity attaches to Mt 11 27 || Lk 10 22, "Son" in "All things have been delivered unto me of my Father: and no one knoweth the Son, save the Father; neither doth any know the Father, save the Son, and he to whomsoever the Son willeth to reveal him." There is a Johannine flavor in these words, and they reveal an intimacy of the Son with the Father, as well as a power over all things, which could not have been conferred by mere official appointment, unless there had been in the background a natural position warranting the official standing. Not infrequently has the word "Messianic" been allowed by scholars to

6. **Higher Use by Jesus Himself** speaks of God as His Father, and to the disciples He speaks of God as their Father; but He never speaks to them of God as their common Father: what He says is, "My Father and your Father" (Jn 20 17). H. J. Holtzmann and others have attempted to make light of this, and even to speak of the opening words of the Lord's Prayer, "Our Father who art in heaven," as if Jesus might have uttered them in company with the disciples; but the distinction is a vital one, and we do not agree with those who can believe that Jesus could have uttered, for Himself along with others, the whole of the Lord's Prayer, including the petition, "Forgive us our debts, as we also have forgiven our debtors."

7. **The Son** attaches to Mt 11 27 || Lk 10 22, "Son" in "All things have been delivered unto me of my Father: and no one knoweth the Son, save the Father; neither doth any know the Father, save the Son, and he to whomsoever the Son willeth to reveal him." There is a Johannine flavor in these words, and they reveal an intimacy of the Son with the Father, as well as a power over all things, which could not have been conferred by mere official appointment, unless there had been in the background a natural position warranting the official standing. Not infrequently has the word "Messianic" been allowed by scholars to

7. **The Son** attaches to Mt 11 27 || Lk 10 22, "Son" in "All things have been delivered unto me of my Father: and no one knoweth the Son, save the Father; neither doth any know the Father, save the Son, and he to whomsoever the Son willeth to reveal him." There is a Johannine flavor in these words, and they reveal an intimacy of the Son with the Father, as well as a power over all things, which could not have been conferred by mere official appointment, unless there had been in the background a natural position warranting the official standing. Not infrequently has the word "Messianic" been allowed by scholars to

any know the Father, save the Son, and he to whomsoever the Son willeth to reveal him." There is a Johannine flavor in these words, and they reveal an intimacy of the Son with the Father, as well as a power over all things, which could not have been conferred by mere official appointment, unless there had been in the background a natural position warranting the official standing. Not infrequently has the word "Messianic" been allowed by scholars to

blind them to the most obvious facts. The conferring of an office on a mere man could not enable him to do things beyond the reach of human powers; yet it is frequently assumed that, if only Jesus was Messiah, He was able for anything, even when the thing in question is something for which a mere man is wholly incompetent.

There is a saying of Jesus (Mk 13 32) about His own Sonship which may seem to refute the church doctrine on the subject, as in it He confesses ignorance of the date of His

**8. The "Son" in Mk 13:32** Second Coming: "Of that day or that hour knoweth no one, not even the angels in heaven, neither the Son, but the Father." Yet, while there is much in this passage fitted to produce sane and sober views as to the real manhood of Jesus, there are few sayings of His that betray a stronger consciousness of His being more than man. Four planes of being and of knowledge are specified—that of men, that of angels, that of Himself, and that of God. Evidently the Son is above not only men but angels, and, if it is confessed that He is ignorant of anything, this is mentioned as a matter of surprise.

The conclusion would seem to be that He is a being intermediate between the angels and God; but this impression is corrected by the greatest of all the sayings in which He calls Himself the Son (Mt 28 18-20), "All authority hath been given unto me in heaven and on earth. Go ye therefore, and make disciples of all the

nations, baptizing them into the name of the Father and of the Son and of the Holy Spirit: teaching them to observe all things whatsoever I commanded you: and lo, I am with you always, even unto the end of the world." Here the Son is named along with the Father and the Holy Spirit in a way suggesting the equality of all three, an act of worship being directed to them jointly. By those who disbelieve in the Deity of Christ, the most strenuous attempts have been made to get rid of this passage, and in certain quarters it is taken for granted that it must have been an addition to the text of this Gospel. But for this there is no ground whatever; the passage is the climax of the Gospel in which it occurs, in the same way as the confession of Thomas is the climax of the Gospel of Jn; and to remove it would be an intolerable mutilation. Of course to those who disbelieve in the bodily resurrection of Our Lord, this has no more substance than the other details of the Forty Days; but to those who believe in His risen glory the words appear to suit the circumstances, their greatness being congruous with the entire representation of the NT.

Indeed, it is the Son of God, as He appears in this final scene in the First Gospel, who dominates the rest of the NT. Thus, in Acts 9 20,

**10. Apostolic Doctrine:** the beginning of Paul's testimony as a Christian is given in these words, "And straightway in the synagogues he proclaimed Jesus, that he is the Son of God"; and what this meant to Paul

may be gathered from his own statement in the opening of Rom, "Paul, a servant of Jesus Christ, called to be an apostle, separated unto the gospel of God, which he promised afore through his prophets in the holy scriptures, concerning his Son, who was born of the seed of David according to the flesh, who was declared to be the Son of God with power, according to the spirit of holiness, by the resurrection from the dead; even Jesus Christ our Lord" (Rom 1 1-4). In He the equality of the Son with the Father is the theme throughout the entire book; and in Rev 2 18, "the Son of God, who hath his eyes like a flame of fire," speaks from the right hand of power to the church.

On this subject there was no division of opinion in the apostolic church. On many other questions the followers of Jesus were divided; but on this one they were unanimous. For this the authority of Paul is often assumed to be responsible; but there was a prior and higher authority. This was the self-testimony of Jesus in the Gospel of Jn. Though this may not have been put in literary form till all the other books of the NT had been completed, it was active and influential in the church all the time, affecting Paul and the other NT writers.

There is no real disharmony between the expression of Our Lord's self-consciousness in the Synoptists and that in Jn; only in the latter it is far ampler and more distinct. Here Jesus is not only called "the Son of God" by others, but applies the title to Himself in its full shape, as well as in the abbreviated form of "the Son." He further calls Himself the

"only begotten Son of God" (3 16,18), that is to say, He is Son in a sense in which no others can claim the title. This seems expressly to contradict the statement, so often made, that He makes others sons of God in the same sense as Himself, or that His Sonship is ethical, not metaphysical. No doubt it is ethical—that is to say, He is like the Father in feeling, mind and will—but it does not follow that it is not at the same time metaphysical. In fact, the perfection of ethical unity depends upon that which is metaphysical. Between a dog and a man there may be deep sympathy, yet it is limited by the difference of their natures; whereas between a woman and a man there is perfect sympathy, because they are identical in nature.

Another feature of Sonship in the Fourth Gospel is preëxistence, though, strange to say, this is more than once connected with the title "Son of man." But the strongest and most frequent suggestions as to what is implied in Sonship are to be found in the deeds attributed to the Son; for these are far beyond the competence of any mere man. Thus, He executes judgment (5 22); He has life in Himself and quickeneth whom He will (5 26,21); He gives eternal life (10 10), and it is the will of the Father that all men should honor the Son, even as they do the Father (5 23). Nevertheless, the Son does nothing of Himself, but only what He hath seen the Father do (5 19); and only that which He hath heard of the Father does He speak (14 10). In short, God is not only His Father, but His God (20 17). To statements such as these a merely official Sonship is not adequate; the relation must be ethical and metaphysical as well; and to a perfect Sonship all three elements are essential.

LITERATURE.—See the books on the Theology of the NT by Weiss, Beyschlag, Holtzmann, Feine, Schlatter, Weinel, Bown, Stevens, Sheldon; and on the Teaching of Jesus by Bruce, Wendt, Dalman; Gore, *The Incarnation of the Son of God, Bampton Lectures*, 1891, and *Dissertations on Subjects Connected with the Incarnation*; Robertson, *Teaching of Jesus concerning God the Father*; full bibliography in Stalker, *Christ's Teaching concerning Himself*.

JAMES STALKER

**SON OF MAN, THE** (ὁ υἱὸς τοῦ ἀνθρώπου, *ho huios tou anthrōpou*):

1. Use in NT: Self-Designation of Jesus
2. Questions as to Meaning
- I. SOURCE OF THE TITLE
  1. The Phrase in the OT—Pss, Ezk, Dnl
  2. "Son of Man" in Dnl 7—NT Allusions
  3. Expressive of Messianic Idea
  4. Post-canonical Literature: Book of En
- II. WHY JESUS MADE USE OF THE TITLE
  1. Consciousness of Being the Messiah
  2. Half Concealed, Yet Half Revealed His Secret
  3. Expressive of Identification with Men in Sympathy, Fortunes and Destiny
  4. Speculations (Lietzmann, Wellhausen, etc) on Aramaic Meaning: These Rejected (Dalman, etc)

LITERATURE

This is the favorite self-designation of Jesus in the Gospels. In Mt it occurs over 30 t, in Mk 15 t, in Lk 25 t, and in Jn a dozen times.

**1. Use in the NT:** It is always in the mouth of Jesus Himself that it occurs, except once, when the bystanders ask what He means by the title (Jn 12 34). Outside the Gospels, it occurs only once in Acts, in Stephen's speech (Acts 7 56), and twice in the Book of Rev (1 13; 14 14).

At first sight it appears so apt a term for the human element in Our Lord's person, the Divine element being similarly denoted by "the Son of God," that this was supposed to be its meaning, as it still is by the common man at the present day. As long as it was assumed that the meaning could be elicited by merely looking at the words as they stand and guessing what they must signify, this was substantially the view of all, although this common conception went in two directions—some noting esp. the loftier and more ideal elements in the conception, while others emphasized what was lowly and painful in the human lot; and both could appeal to texts in support of their view. Thus, the view "that Christ by this phrase represented Himself as the head, the type, the ideal of the race" (Stanton, *The Jewish and the Christian Messiah*), could appeal to such a saying as, "The Son of man is Lord even of the sabbath" (Mk 2 28); while the humbler view could quote such a saying as, "The foxes have holes, and the birds of the heaven have nests; but the Son of man hath not where to lay his head" (Mt 8 20).

The more scientific investigation of the phrase began, however, when it was inquired, first, what the source was from which Jesus derived this title, and, secondly, why He made use of it.

**1. Source of the Title.**—That the phrase was not one of Jesus' own invention is manifest, because it occurs often in the OT. Thus, in Ps 8 4 it is used as an equivalent for "man" in the parallel lines,

**1. The Phrase in the OT (Pss, Ezk, Dnl)**

Ps 8 4 it is used as an equivalent for "man" in the parallel lines,  
"What is man, that thou art mindful of him?  
And the son of man, that thou visitest him?"

This passage has sometimes been regarded as the source whence Jesus borrowed the title; and for this a good deal might be said, the ps being an incomparable exposition both of the lowliness and the loftiness of human nature. But there is another passage in the Pss from which it is far from incredible that it may have been derived: in Ps 80 17 occur the words,

"Let thy hand be upon the man of thy right hand,  
Upon the son of man whom thou madest strong for thyself."

This is an appeal, in an age of national decline, for the raising up of a hero to redeem Israel; and it might well have kindled the spark of Messianic consciousness in the heart of the youthful Jesus.

There is a book of the OT in which the phrase "the son of man" occurs no fewer than 90 t. This is the Book of Ezk, where it is always applied to the prophet himself and designates his prophetic mission. In the words of Nösgen (*Christus der Menschen- und Gottessohn*): "It expresses the contrast between what Ezekiel is in himself and what God will make out of him, and to make his mission appear to him not as his own, but as the work of God, and thus to lift him up, whenever the flesh threatens to faint and fail." Thus there was one before Jesus of Nazareth who bore the title, at least in certain moments of his life; and, after Ezekiel, there arose another Heb prophet who has put on record that he was addressed from the same high

quarter in the same terms; for, in Dnl 8 17, it is written, "So he came near where I stood; and when he came, I was affrighted, and fell upon my face: but he said unto me, Understand, O son of man"—words then following intended to raise the spirit of the trembling servant of God. By Weizsäcker and others the suggestion has been made that Jesus may have borrowed the term from Ezk and Dnl to express His consciousness of belonging to the same prophetic line.

There is, however, in the same Book of Dnl another occurrence of the phrase, in a totally different sense, to which the attention

**2. "Son of Man" in Dnl 7—NT Allusions**

of science is more and more being drawn. In 7 3 ff, in one of the apocalyptic visions common to this prophetic, four beasts are seen coming out of the sea—the first a lion with

eagle's wings, the second a bear, the third a four-headed leopard, and the fourth a terrible monster with ten heads. These beasts bear rule over the earth; but at last the kingdom is taken away from them and given to a fifth ruler, who is thus described, "I saw in the night-visions, and, behold, there came with the clouds of heaven one like unto a son of man, and he came even to the ancient of days, and they brought him near before him. And there was given him dominion, and glory, and a kingdom, that all the peoples, nations, and languages should serve him: his dominion is an everlasting dominion, which shall not pass away, and his kingdom that which shall not be destroyed" (vs 13.14). Compare with these words from Dnl the words of Jesus to the high priest during His trial, "Henceforth ye shall see the Son of man sitting at the right hand of Power, and coming on the clouds of heaven" (Mt 26 64), and the echo of the OT words cannot be mistaken. Equally distinct is it in the great discourse in Mt 24 30, "Then shall appear the sign of the Son of man in heaven: and then shall all the tribes of the earth mourn, and they shall see the Son of man coming on the clouds of heaven with power and great glory."

The use of this self-designation by Jesus is esp. frequent and striking in passages referring to His future coming to judgment, in which

**3. Expressive of Messianic Idea**

there is necessarily a certain resemblance to the apocalyptic scene in Dnl. In such utterances the Messianic consciousness of Jesus is most emphatically expressed; and the passage in

Dnl is also obviously Messianic. In another considerable series of passages in which this phrase is used by Jesus, the references are to His sufferings and death; but the assumption which explains these also most easily is that they are Messianic too; Jesus is speaking of the fortunes to which He must submit on account of His vocation. Even the more dignified passages, expressive of ideality, are best explained in the same way. In short, every passage where the phrase occurs is best understood from this point of view, whereas, from any other point of view, not a few appear awkward and out of place. How little, for example, does the idea that the phrase is expressive of lowliness or of brotherhood with suffering humanity accord with the opening of the judgment-scene in Mt 25 31, "But when the Son of man shall come in his glory, and all the angels with him, then shall he sit on the throne of his glory"!

The son of man, or rather "one like unto a son of man" mentioned in Dnl, is primarily the Heb people, as is expressly noted in the prophecy itself; but Jesus must have looked upon Himself as the representative of the people of God, in the same way as, in the OT generally, the reigning sovereign was regarded as the representative of

the nation. But the question has been raised whether this transference of the title from a collective body to an individual may have been mediated for Him through post-canonical canonical religious literature or the Literature: prevalence among the people of ideas Book of En generated through this literature. In the Book of En there occur numerous references to the son of man, which bear a remarkable resemblance to some of the sayings of Jesus. The date usually assigned to this production is some 200 years BC; and, if these passages in it actually existed as early as this, the book would almost require to be included in the canonical Scriptures, though for other reasons it is far from worthy of any such honor. The whole structure of the Book of En is so loose and confused that it must always have invited interpolation; and interpolations in it are recognized as numerous. The probability, therefore, is that the passages referring to the son of man are of later date and of Christian origin.

**II. Why Jesus Made Use of the Title.**—The conclusion that this title expresses, not the personal qualities of Jesus as a man, but His functions as Messiah, may be disappointing; but there is a way of recovering what seems to have been lost; because we must now inquire for what reasons He made use of this term.

The first reason, of course, is, that in Dnl it expressed Messiahship, and that Jesus was conscious of being the Messiah. In the OT He was wont all His days to read His own history. He ranged over all the sacred books and found in them references to His own person and work. With divinatory glance

He pierced into the secrets of Scripture and brought forth from the least as well as the best-known portions of the ancient oracles meanings which are now palpable to all readers of the Bible, but which He was the first to discover. From the passage in Dnl, or from some other passage of the OT in which the phrase "the son of man" occurs, a hint flashed out upon Him, as He read or heard; and the suggestion grew in His brooding mind, until it rounded itself into the fit and satisfying expression for one side of His self-consciousness.

Another reason why He fixed upon this as His favorite self-designation may have been that it half concealed as well as half revealed

**2. Half Concealed Yet Half Revealed His Secret** His secret. Of the direct names for the Messiah He was usually shy, no doubt chiefly because His contemporaries were not prepared for an open declaration of Himself in this character; but at all stages of His ministry He called Himself the Son of man without hesitation. The inference seems to be, that, while the phrase expressed much to Himself, and must have meant more and more for those immediately associated with Him, it did not convey a Messianic claim to the public ear. With this accords well the perplexity once manifested by those listening to Him, when they asked, "Who is this Son of man?" (Jn 12 34); as it also explains the question of Jesus to the Twelve at Caesarea Philippi, "Who do men say that the Son of man is?" or, as it is in the margin, "that I the Son of man am?" (Mt 16 13). That He was the Son of man did not evidently mean for all that He claimed to be the Messiah.

But when we try to realize for what reasons Jesus may have picked this name out from all which presented themselves to Him in His intimate and loving survey of the OT, it is difficult to resist the belief that a third and the principal reason was because it gave expression to His sense of connection with all men in sympathy, for-

tunes and destiny. He felt Himself to be identified with all as their brother, their fellow-sufferer, their representative and champion; and, in

**3. Expressive of Identification with Men** some respects, the deepest word He ever spake was, "For the Son of man also came not to be ministered unto, but to minister, and to give his life a ransom for many" (Mk 10 45 ||).

In 1896, Hans Lietzmann, a young German scholar, startled the learned world with a speculation on the "Son of man." Making the assumption that Aram. was the language spoken by Jesus, he contended that Jesus could not have applied to Himself the Messianic title, because there is nothing corresponding with it in Aramaic. The only term approximating to it is *barnash*, which means something very vague, like "any-one" or "everyman" (in the sense of the old morality play thus entitled). Many supposed Lietzmann to be arguing that Jesus had called Himself Anyone or Everyman; but this was not his intention. He tried to prove that the Messianic title had been applied to Jesus in Asia Minor in the first half of the 2d cent. and that the Gospels had been revised with the effect of substituting it for the first personal pronoun. But he failed to show how the MSS could have been so universally altered as to leave no traces of this operation, or how, if the text of the NT was then in so fluid a state as to admit of such a substitution, the phrase should not have overflowed into other books besides the Gospels. Although the hypothesis has secured wide attention through being partially adopted by Wellhausen, whose view is to be found in *Skizzen und Vorarbeiten*, VI, and at p. 66 of his *Comm. on Mk*, it may be reckoned among the ghosts which appear for an hour on the stage of learning, attracting attention and admiration, but have no permanent connection with the world of reality. Dalman, the leading authority on Aram., denies the foundation on which the views of both Lietzmann and Wellhausen rest, and holds that, had the Messianic title existed, the Aram. language would have been quite capable of expressing it. And in 1911 Wellhausen himself explicitly admitted this (*Einleitung in die drei ersten Evangelien*<sup>2</sup>, 130).

**4. Speculations on Aramaic Meaning** LITERATURE.—See the books on NT Theology by Weiss, Beyschlag, Holtzmann, Feine, Schlatter, Weinel, Stevens, Sheldon; and on the Teaching of Jesus by Wendt, Bruce, Dalman; Abbott, *The Son of Man*, 1910; very full bibliography in Stalker, *The Teaching of Jesus concerning Himself*.

JAMES STALKER

**SONG** (שִׁיר, *shūr*, שִׁירָה, *shūrah*): Besides the great collection of sacred songs contained in the Psalter, as well as the lyric outbursts, marked by strong religious feeling, on great national occasions, it is natural to believe, and we have evidence to show, that the Hebrews possessed a large number of popular songs of a secular kind. Song of Songs (q.v.) of itself proves this. Probably the very oldest song or fragment of song in the OT is that "To the well" (Nu 21 17).

W. R. Smith (*Religions of the Semites*, 167) regards this invocation of the waters to rise as its origin hardly a mere poetic figure. He compares what *Cassini* 1, 189, records of the well of *Tabistan*: "When the water failed, a feast was held at its source with music and dancing to induce it to flow again." If, however, the song had its origin in an early form of religious belief, it must have been secularized later.

But it is in the headings of the Pss that we find the most numerous traces of the popular songs of the Hebrews. Here there are a number of words and phrases which are now believed to be the names or initial words of such lyrics. In AV they are prefaced with the prep. "on," in RV with "set to," i.e. "to the tune of." We give a list: (1) *Aijeleth Shahar* AV, RV *Aijeleth hash-shahar*, 'ayyeleth ha-shahar. The title means (RVm) "The hind of the morning," but whether the original song so named was a hunting song or a morning serenade it is useless to conjecture. See HIND OF THE MORNING. (2) *Al-tashith* (AV), *Al-tashheth* (RV), 'al-tashhēth, i.e. "Destroy not," Pss 57-59, 75, is apparently quoted in Isa 65 8, and in that case must refer to a vintage song. (3) *Jonah elem rehokim* or *Yonath-ēlem r'hōkīm* (Ps 56), RVm "The silent dove of them that are afar off," or—with a slightly different

reading—"The dove of the distant terebinths." (4) *Mahälath* (Ps 53) and *Mahälath l'annöth* (Ps 88). *Mahälath* may mean "sickness," and be the first word of a song. It might mean, on the other hand, a minor mode or rhythm. It has also been held to designate a musical instrument. (5) *Müth-labbën* (Ps 9) has given rise to many conjectures. Lit. it may mean "Die for the son," or "Death of the son." An ancient tradition referred the words to Goliath (death at the hand of the son [?]), and they have been applied to the fate of Absalom. Such guesses need only be quoted to show their worthlessness. (6) Lastly, we have *Shöshannim* = "Lilies" (Pss 45, 69), *Shüshan 'Édhüth* = "The lily of testimony" (Ps 60); and *Shöshannim 'Édhüth* = "Lilies, a testimony" (Ps 80), probably to be explained like the others.

The music to which these songs were sung is irretrievably lost, but it was, no doubt, very similar in character to that of the Arabs at the present day. While the music of the temple was probably much more elaborate, and of wider range, both in notes and expression of feeling, the popular song was almost certainly limited in compass to a very few notes repeated over and over in long recitations or ballads. This is characteristic of the performances of Arab minstrels of today. The melodies are plaintive, in spite of the majority of them being in major keys, owing to the 7th being flattened, as in genuine Scots music. Arab music, further, is marked by great variety and emphasis of rhythm, the various kinds of which have special names. See SPIRITUAL SONGS.

JAMES MILLAR

SONG OF SONGS (שִׁיר הַשִּׁירִים, *shir ha-shürim*; LXX "Ἄσμα, *Ásma*; Ἄ C, "Ἄσμα ἄσμα-των, *Ásma asmátôn*; Vulg *Canticum Canticorum*):

- I. CANONICITY
- II. TEXT
- III. AUTHORSHIP AND DATE
- IV. HISTORY OF INTERPRETATION
  1. The Allegorical Interpretation
  2. The Typical Interpretation
  3. The Literal Interpretation
- V. CLOSING HINTS AND SUGGESTIONS

LITERATURE

The full title in Heb is "The Song of Songs, which is Solomon's." The book is called by some Canticles, and by others Solomon's Song. The Heb title implies that it is the choicest of all songs, in keeping with the dictum of R. 'Akiba (90-135 AD) that "the entire world, from the beginning until now, does not outweigh the day in which Canticles was given to Israel."

**I. Canonicity.**—Early Jewish and Christian writers are silent as to the Song of Songs. No use is made of it by Philo. There is no quotation from it in the NT, nor is there any clear allusion to it on the part of Our Lord or the apostles. The earliest distinct references to the Song of Songs are found in Jewish writings of the 1st and 2d cents. AD (4 *Esd* 5 24.26; 7 26; *Ta'ânüth* 4 8). The question of the canonicity of the Song was debated as late as the Synod of Jamnia (c 90 AD), when it was decided that Canticles was rightly reckoned to "defile the hands," i.e. was an inspired book. It should be borne in mind that the Song of Songs was already esteemed by the Jews as a sacred book, though prior to the Synod of Jamnia there was probably a goodly number of Jewish teachers who did not accept it as canonical. Selections from Canticles were sung at certain festivals in the temple at Jerus, prior to its destruction by Titus in 70 AD (*Ta'ânüth* 4 8). The Mish pronounces an anathema on all who treat Canticles as a secular song (*Sanhedhrin*, 101a). The latest date for the composition of the Song of Songs, according to critics of the advanced school, is toward the close of the 3d cent. BC. We may be

sure that it was included in the *K'ithübbim* before the ministry of Our Lord, and so was for Him a part of the Scriptures.

**II. Text.**—Most scholars regard the text of Canticles as comparatively free from corruption. Grätz, Bickell, Budde and Cheyne have suggested a good many emendations of the traditional text, a few of which commend themselves as probable corrections of a faulty text, but most of which are mere guesses without sufficient confirmation from either external or internal evidence. For details see Budde's able commentary, and articles by Cheyne in *JQR* and *Expos T* for 1898-99 and in the *Expos*, February, 1899.

**III. Authorship and Date.**—The title in the Heb text ascribes the poem to Solomon. That this superscription was prefixed by an editor of Canticles and not by the original writer is evident from the fact that the relative pronoun employed in the title is different from that employed throughout the poem. The beauty and power of the book seemed to later students and editors to make the writing worthy of the gifted king, whose fame as a composer of both proverbs and songs was handed on to later times (1 K 4 32). Moreover, the name of Solomon is prominent in the Song of Songs itself (1 5; 3 7.9.11; 8 11 f). If the traditional view that Solomon wooed and won the Shulammitte be true, the Solomonic authorship may even yet be defended, though the linguistic argument for a later date is quite strong.

The question in debate among recent critics is whether the Song was composed in North Israel in præxilic days, or whether it is post-exilic. The author is at home in Heb. His vocabulary is extensive, and the movement of the poem is graceful. There is no suggestion of the use of lexicon and grammar by a writer living in the period of the decadence of the Heb language. The author is familiar with cities and mountains all over Pal, esp. in the northern section. He speaks of the beauty of Tirzah, the capital of North Israel in the 10th cent. BC, along with the glory of Jerus, the capital of Judah (6 4). The recollection of Solomon's glory and pomp seems to be fresh in the mind of the writer and his contemporaries. W. R. Smith regarded Canticles as a protest against the luxury and the extensive harem of Solomon. True love could not exist in such an environment. The fidelity of the Shulammitte to her shepherd lover, notwithstanding the blandishments of the wealthy and gifted king, stands as a rebuke to the notion that every woman has her price. Driver seems inclined to accept a præxilic date, though the arguments from vocabulary and philology cause him to waver in his opinion (*LOT*, 8th ed, 450). An increasing number of critics place the composition of Canticles in the post-exilic period, many bringing it down into the Gr period. Among scholars who date Canticles in the 3d cent. BC we may name Grätz, Kuenen, Cornill, Budde, Kautzsch, Martineau and Cheyne. The chief argument for bringing the Song into the time of the early Ptolemies is drawn from the language of the poem. There are many Heb words that are employed elsewhere only in later books of the OT; the word *pardēs* (4 13) is a Pers loan-word for "park"; the word for "palanquin" may be Indian, or possibly Gr. Moreover, the form of the relative pronoun is uniformly that which is found in some of the latest books of the OT. The influence of Aram. is apparent, both in the vocabulary and in a few constructions. This may be accounted for on the theory of the northern origin of the Song, or on the hypothesis of a post-exilic date. The question of date is still open.

**IV. History of Interpretation.**—All interpreters of all ages agree in saying that Canticles is a poem

of love; but who the lovers are is a subject of keen debate, esp. in modern times.

First in point of time and in the number of adherents it has had is the theory that the Song is a pure allegory of the love of Jeh and His people. The Jewish rabbis, from the latter part of the 1st cent. AD down to our own day, taught that the poem celebrates a spiritual love, Jeh being the bridegroom and Israel the bride. Canticles was supposed to be a vivid record of the loving intercourse between Israel and her Lord from the exodus on to the glad Messianic time. The Song is read by the Jews at Passover, which celebrates Jeh's choice of Israel to be His spouse. The Tg interprets Canticles as an allegory of the marital love of Jeh and Israel. Origen made the allegorical theory popular in the early church. As a Christian he represented the bride as the church or the soul of the believer. In more recent centuries the Christian allegorical interpreters have favored the idea that the soul of the believer was the bride, though the other type of the allegorical view has all along had its advocates.

Bernard of Clairvaux wrote 86 sermons on the first two chapters of Canticles; and a host of writers in the Roman church and among Protestants have composed similar mystical treatises on the Song. Devout souls have expressed their fervent love to God in the sensuous imagery of Canticles. The imagery could not become too fervid or ecstatic for some of these devout men and women in their highest moments of beatific vision. Whatever may be the final verdict of sane criticism as to the original purpose of the author of the Song, it is a fact that must not be overlooked by the student of Canticles that some of the noblest religious souls, both Heb and Christian, have fed the flame of devotion by interpreting the Song as an allegory.

What justification is there for the theory that Canticles is an allegory of the love between Jeh and His people, or of the love of Christ and the church, or of the love of the soul of the believer and Christ? It must be frankly confessed that there is not a hint in the Song itself that it is an allegory. If the modern reader of Canticles had never heard of the allegorical interpretation, nothing in the beginning, middle or end of the poem would be likely to suggest to his mind such a conception of the poet's meaning. How, then, did the early Jewish interpreters come to make this the orthodox interpretation of the Song? The question is not easy to answer. In the forefront of our answer we must recall the fact that the great prophets frequently represent the mutual love of Jeh and Israel under the symbolism of marriage (Hos 1-3; Jer 3; Ezk 16, 23; Isa 50 1; 54 5.6). The Heb interpreter might naturally expect to find some echo of this bold imagery in the poetry of the *K'thūbhim*. In the Torah the frequent command to love Jeh might suggest the marital relation as well as that of the father and son (Dt 6 5; 7 7-9.13; 10 12.15; 30 16.20), though it must be said that the language of Dt suggests the high ethical and religious teaching of Jesus in the matter of love to God, in which the sexual does not appear.

Cheyne suggests (*EB*, I, 683 f) that the Song was too joyous to be used, in its natural sense, by the Jews after the destruction of Jerus, and hence they consecrated it by allegorical interpretation. The suggestion may contain an element of truth.

It is an interesting fact that the Psalter has so few expressions in which love to Jeh is expressed (31 23; 97 10; 145 20; cf 18 1; 42 1; 63 1). In this manual of devotion one would not be surprised to find the expansion of the image of wedlock as expressive of the soul's relation to God; but we look in vain for such a poem, unless Ps 45 be capable of allegorical interpretation. Even that beautiful song of love and marriage contains no such highly sensuous imagery as is found in Canticles.

Christian scholars found it easy to follow the Jewish allegorical interpreters; for the figure of wedlock is employed in the NT by both Paul and

John to represent the intimate and vital union of Christ and His church (2 Cor 11 2; Eph 5 22-33; Rev 19 7-9; 21 2.9 ff).

The entire body of true believers is conceived of as the bride of Christ. Naturally the purity of the church is sullied through the impure conduct of the individuals of whom it is composed. Hence the appeal to individuals and to local churches to live pure lives (2 Cor 11 1). To the unmarried believer the Lord Jesus takes the place of the husband or wife as the person whom one is most eager to please (1 Cor 7 32 f). It is not difficult to understand how the fervid, sensuous imagery of Canticles would appeal to the mind of a man like Origen as a proper vehicle for the expression of his passionate love for Christ.

Sober inquiry discovers no sufficient justification of the allegorical interpretation of the Song of Songs. The pages of the mystical commentators are filled with artificial interpretations and conceits. Many of them practise a familiarity with Christ that is without example in the Bib. devotional literature.

The allegorical interpreters, for the most part, saw in the Song of Songs no historic basis. Solomon and the Shulammitte are introduced merely as figures through whom God and His people, or Christ and the soul, can express their mutual love.

In modern times interpreters have arisen who regard the Song as primarily the expression of strong and passionate human love between Solomon and a beautiful maiden, but by virtue of the typical relation of the old dispensation, secondarily, the fitting expression of the love of Christ and the church.

The way for this modern typical interpretation was prepared by Lowth (*Sacred Poetry of the Hebrews*, Lects XXX, XXXI) in his modified allegorical view, which is thus described by Canon Driver: "Bishop Lowth, though not abandoning the allegorical view, sought to free it from its extravagances; and while refusing to press details, held that the poem, while describing the actual nuptials of Solomon with the daughter of Pharaoh, contained also an allegoric reference to Christ espousing a church chosen from among the Gentiles" (*LOT*, 451). Few interpreters have been found to follow Theodore of Mopsuestia and Lowth in their view that the Song celebrates the marriage of Solomon and an Egypt princess; and Lowth's notion of a reference to the espousal of a church chosen from among the Gentiles is one of the curiosities of criticism. Of the typical interpreters Delitzsch is perhaps the ablest (*Comm. on Ecclesiastes and the Song of Songs*).

The typical commentators are superior to the allegorical in their recognition of Canticles as the expression of the mutual love of two human beings. The further application of the language to Jeh and His people (Keil), or to Christ and the church (Delitzsch), or to God and the soul (M. Stuart) becomes largely a matter of individual taste, interpreters differing widely in details.

Jewish interpreters were deterred from the literal interpretation of Canticles by the anathema in the Mish upon all who should treat the poem as a secular song (*Sanhedhrin*, 101a). Cheyne says of Ibn Ezra, a great mediaeval Jewish scholar, he "is so thorough in his literal exegesis that it is doubtful whether he is serious when he proceeds to allegorise." Among Christian scholars Theodore of Mopsuestia interpreted Canticles as a song in celebration of the marriage of Solomon and Pharaoh's daughter. This strictly literal interpretation of the Song was condemned at the second council of Constantinople (553 AD). For the next thousand years the allegorical theory reigned supreme among Christian interpreters. In 1544 Sebastian Castelleo revived the literal theory of the Song, though the allegorical view remained dominant until the 19th cent.

Herder in 1778 published a remarkable little treatise entitled *Lieder der Liebe, die ältesten und schönsten aus dem Morgenlande*, in which he ad-

vanced the theory that Canticles is a collection of independent erotic songs, about 21 in number, which have been so arranged by a collector as to trace "the gradual growth of true love in its various *nuances* and stages, till it finds its consummation in wedlock" (Cheyne). But the greatest and most influential advocate of the literal interpretation of Canticles was Heinrich Ewald, who published the 1st ed of his comm. in 1826. It was Ewald who first developed and made popular the theory that two suitors compete for the hand of the Shulammitte, the one a shepherd and poor, the other a wise and wealthy king. In the Song he ascribes to Solomon 1 9-11.15; 2 2; 4 1-7; 6 4-13 (quoting the dialogue between the Shulammitte and the ladies of the court in vs 10-13); 7 1-9. To the shepherd lover he assigns few verses, and these are repeated by the Shulammitte in her accounts of imaginary or real interviews with her lover. In the following passages the lover described is supposed to be the shepherd to whom the Shulammitte had plighted her troth: 1 2-7.9-14; 1 16-2 1; 2 3-7.8-17; 3 1-5; 4 8-5 1; 5 2-8; 5 10-16; 6 2 f; 7 10-8 4; 8 5-14. The shepherd lover is thus supposed to be present in the Shulammitte's dreams, and in her waking moments she is ever thinking of him and describing to herself and others his many charms. Not until the closing scene (8 5-14) does Ewald introduce the shepherd as an actor in the drama. Ewald had an imperial imagination and a certain strength of mind and innate dignity of character which prevented him from dragging into the mud any section of the Bib. lit. While rejecting entirely the allegorical theory of Canticles, he yet attributed to it an ethical quality which made the Song worthy of a place in the OT. A drama in praise of fidelity between human lovers may well hold a place beside Eccl and Prov in the Canon. Many of the ablest OT critics have followed Ewald in his general theory that Canticles is a drama celebrating the loyalty of a lowly maiden to her shepherd lover. Not even Solomon in all his glory could persuade her to become his queen.

Within the past quarter of a century the unity of Canticles has been again sharply challenged. An account of the customs of the Syrian peasants in connection with weddings was given by the Prussian consul at Damascus, J. G. Wetzstein, in 1873, in an article in Bastian's *Zeitschrift für Ethnologie*, 270 ff, on "Die syrische Dreschtafel," in which he illustrated the OT from modern Syrian customs. Driver thus describes the customs that are supposed to throw light upon Canticles: "In modern Syria, the first seven days after a wedding are called the 'king's week'; the young pair play during this time king and queen; the 'threshing-board' is turned into a mock-throne, on which they are seated, while songs are sung before them by the villagers and others, celebrating them on their happiness, among which the *wac̄f*, or poetical 'description' of the physical beauty of the bride and bridegroom, holds a prominent place. The first of these *wac̄fs* is sung on the evening of the wedding-day itself: brandishing a naked sword in her right hand, and with a handkerchief in her left, the bride dances in her wedding array, lighted by fires, and surrounded by a circle of guests, half men and half women, accompanying her dance with a *wac̄f* in praise of her charms" (*LOT*, 452). Wetzstein suggested the view that Canticles was composed of the wedding-songs sung during "the king's week." This theory has been most fully elaborated by Budde in an article in the *New World*, March, 1894, and in his comm. (1898). According to Budde, the bridegroom is called King Solomon, and the bride *Shūlammūth*. The companions of the bridegroom are the 60 valiant men who form his escort (3 7). As a

bride, the maiden is called the most beautiful of women (1 8; 5 9; 6 1). The pictures of wedded bliss are sung by the men and women present, the words being attributed to the bride and the bridegroom. Thus the festivities continue throughout the week. Budde's theory has some decided advantages over Ewald's view that the poem is a drama; but the loss in moral quality is considerable; the book becomes a collection of wedding-songs in praise of the joys of wedlock.

**V. Closing Hints and Suggestions.**—Having given a good deal of attention to Canticles during the past 15 years, the author of this article wishes to record a few of his views and impressions.

(1) Canticles is lyric poetry touched with the dramatic spirit. It is not properly classed as drama, for the Hebrews had no stage, though much of the OT is dramatic in spirit. The descriptions of the charms of the lovers were to be sung or chanted.

(2) The amount that has to be read between the lines by the advocates of the various dramatic theories is so great that, in the absence of any hints in the body of the book itself, reasonable certitude can never be attained.

(3) The correct tr of the refrain in 2 7 and 3 5 (cf 8 4) is important for an understanding of the purpose of Canticles. It should be rendered as follows:

'I adjure you, O daughters of Jerusalem,  
By the gazelles, or by the hinds of the field,  
That ye stir not up, nor awaken love,  
Until it please.'

Love between man and woman should not be excited by unnatural stimulants, but should be free and spontaneous. In 8 4 it seems to be implied that the women of the capital are guilty of employing artifices to awaken love:

'I adjure you, O daughters of Jerusalem,  
Why do ye stir up, or awaken love,  
Until it please?'

That this refrain is in keeping with the purpose of the writer is clear from the striking words toward the close of the book:

"Set me as a seal upon thy heart,  
As a seal upon thine arm;  
For love is strong as death;  
Jealousy is cruel as Sheol;  
The flashes thereof are flashes of fire,  
A very flame of Jehovah.  
Many waters cannot quench love,  
Neither can floods drown it:  
If a man would give all the substance of his  
house for love,  
He would utterly be contemned" (8 6 f).

(4) Canticles discloses all the secret intimacies of wedded life without becoming obscene. The imagery is too sensuous for our taste in western lands, so that words of caution are often timely, lest the sensuous degenerate into the sensual; but I have been told by several Syrian and Palestinian students whom I have had the privilege of teaching, that Canticles is considered quite chaste among their people, the wedding-songs now in use among them being more minute in their description of the physical charms of the lovers.

(5) Canticles is by no means excluded from the Canon by the acceptance of the literal interpretation. Ewald's theory makes it an ethical treatise of great and permanent value. Even if Canticles is merely a collection of songs describing the bliss of true lovers in wedlock, it is not thereby rendered unworthy of a place in the Bible, unless marriage is to be regarded as a fall from a state of innocency. If Canticles should be rejected because of its sensuous imagery in describing the joys of passionate lovers, portions of Prov would also have to be excised (Prov 5 15-20). Perhaps most persons need to enlarge their conception of the Bible as a repository for all things that minister to the welfare of men. The entire range of man's legitimate joys finds sympathetic and appreciative description in the Bible. Two young lovers in Paradise

need not fear to rise and meet their Creator, should He visit them in the cool of the day.

LITERATURE.—C. D. Ginsburg, *The Song of Songs, with a Comm., Historical and Critical*, 1857; H. Ewald, *Dichter des Alten Bundes*, III, 333–426, 1867; F. C. Cook, in *Bib. Comm.*, 1874; Franz Delitzsch, *Hoheslied u. Kehoheleth*, 1875 (also tr); O. Zöckler, in *Lange's Comm.*, 1875; S. Oettli, *Kurzgefasster Kommentar*, 1889; W. E. Griffis, *The Lily among Thorns*, 1890; J. W. Rothstein, *Das Hohe Lied*, 1893; K. Budde, art. in *New World*, March, 1894, and *Kommentar*, 1898; C. Siegfried, *Prediger u. Hoheslied*, 1898; A. Harper, in *Cambridge Bible*, 1902; G. C. Martin, in *Century Bible*, 1908; art. on "Canticles" by Cheyne in *EB*, 1899.

JOHN RICHARD SAMPEY

SONG OF THE THREE CHILDREN:

1. Name
  2. Canonicity
  3. Contents
  4. Author and Date
  5. Original Language
  6. Text and Versions
- LITERATURE

For general remarks concerning the Additions to Daniel see BEL AND THE DRAGON.

This Addition has no separate title in any MS or VS because in the LXX, Theod, Syr and Lat (Old Lat and Vulg) it follows Dnl 3 23

1. Name immediately, forming an integral portion of that chapter, viz. vs 24–90 in the LXX and Vulg. It is the only one of the three Additions which has an organic connection with Dnl; as regards the others see preliminary remarks to BEL AND THE DRAGON. The title in EV is "The Song of the Three Holy Children," a title describing its matter as formerly understood, though a more rigid analysis shows that in the 68 verses so designated, we have really two separate sections. See 3, below.

See introductory remarks to BEL AND THE DRAGON. The order in which the three "Additions to Dnl" are found in the (Separate Protestant)

2. Canon- Apoc is decided by their sequence  
icity in the Vulg, the Song of the Three Children forming part of ch 3, Sus of ch 13, and Bel of ch 14 of Dnl.

Though the Eng. and other Protestant VSS treat the 68 verses as one piece under the name given above, there are really two quite

3. Contents distinct compositions. These appear separately in the collection of Odes appended to the Psalter in Cod. A under the headings, "The Prayer of Azarias" (Προευχή Ἀζαρίου, *Pro-euchē Azariou*, Azariah, Dnl 1 6f) and "The Hymn of Our Fathers" (Ἕμνος τῶν πατέρων ἡμῶν, *Hymnos tōn patērōn hēmōn*); see Swete, *The OT in Gr*, 3804 ff, and *Intro to the OT in Gr*, 253 f. Luther with his usual independence makes each of these into a separate book under the titles, "The Prayer of Azaria" (*Das Gebet Asarjas*) and "The Song of the Three Men in the Fire" (*Der Gesang der drei Männer im Feuerofen*).

(1) *The Prayer of Azarias (vs 1–22) (Dnl 3 24–48)*.—Azariah is the Heb name of Abed-nego (= Abednebo, "servant of Nebo"), the latter being the Bab name (see Dnl 1 7; 2 49, etc). This prayer joins on to Dnl 3 23, where it is said that "Shadrach, Meshach and Abed-nego [Azariah] fell down bound into the midst of the burning fiery furnace." Θ (the VS of Theodotion; see "Text and Versions" below) adds, "And they walked [Syr adds "in their chains"] in the midst of the fire, praising God, and blessing the Lord." This addition forms a suitable connecting link, and it has been adopted by the Vulg and in modern VSS which are made from Θ and not from the LXX, which last was lost for many centuries (see BEL AND THE DRAGON, III). In the LXX the words with which the Prayer was introduced are these: "Thus therefore prayed Hananias, and Azarias and Misael and sang praises [hymns] to the Lord when the king commanded

that they should be cast into the furnace." The prayer (offered by Azarias) opens with words of adoration followed by an acknowledgment that the sufferings of the nation in Babylon were wholly deserved, and an earnest entreaty that God would intervene on behalf of His exiled and afflicted people. That this prayer was not composed for the occasion with which it is connected goes without saying. No one in a burning furnace could pray as Azarias does. There are no groans or sighs, nor prayer for help or deliverance of a personal nature. The deliverance sought is national.

(2) *The Song of the Three Holy Children (vs 28–68) (Dnl 3 51–90)*.—This is introduced by a brief connecting narrative (vs 23–27). The king's servants continued to heat the furnace, but an angel came down and isolated an inner zone of the furnace within which no flames could enter; in this the three found safety. Rothstein (Kautzsch, *Die Apok.*, 175) is inclined to think that this narrative section (vs 23–27) stood between Dnl 3 23 and 3 24 in the original Heb text. The "Song" is really a ps, probably a tr of a Heb original. It has nothing to do with the incident—the three young men in the furnace—except in ver 66 (EV) where the three martyrs call upon themselves by name to praise and bless the Lord for delivering them from the midst of the furnace. This verse is an interpolation, for the rest of the Song is a long litany recalling Ps 103 and esp. Pss 136, 148, and Sir 43. The Song, in fact, has nothing to do with the sufferings of the three young men, but is an ordinary hymn of praise. It is well known from the fact that it forms a part of the Anglican Prayer-book, as it had formed part of many early Christian liturgies.

(1) We know nothing whatever of the author besides what may be gathered from this Addition.

4. Author It is quite evident that none of the three Additions belong to the original text of Dnl, and that they were added because they contained legends in keeping with the spirit of that book, and a song in a slight degree (ver 66 EV) adapted to the situation of the three Heb youths in the furnace, though itself of an independent liturgical origin.

For a long time the three Additions must have circulated independently. Polychronius says that "The Song of the Three Holy Children" was, even in the 5th cent. AD, absent from the text of Dnl, both in the Pesh and in the LXX proper. Rothstein (Kautzsch, *Die Apok.*, 176) contends that the Additions formed a part of the LXX from the beginning, from which he infers that they were all composed before the LXX was made. What was the date of this VS of Dnl? Since its use seems implied in 1 Macc 1 54 (cf Dnl 11 31; 12 11), it would be safe to conclude that it existed about 100 BC.

(2) *Date of the Prayer of Azarias*.—In ver 15 (EV) it is said that at the time the prayer was offered, there was no prince, prophet or leader, nor sacrifice of any kind. This may point to the time between 168 and 165 BC, when Antiochus IV (Epiphanes) profaned the temple. If written in that interval, it must have been added to Dnl at a much later time. But on more occasions than one, in later times, the temple-services were suspended, as e.g. during the invasion of Jerus by the Egypt king, Ptolemy IV (Philopater).

(3) *Date of the Song*.—We find references in the Song (vs 62 f EV) to priests and temple-servants, and in ver 31 to the temple itself, suggesting that when the Song was written the temple-services were carried on. This, in itself, would suit a time soon after the purification of the temple, about 164 BC. But the terms of the Song are, except in ver 66 (EV), so general that it is impossible to fix the date definitely. On the date of the historical connecting narrative (vs 23–27) see 3, (2), above.



(1) Romanist scholars in general and several Protestants (Eichhorn, *Einleit.*, in *das AT*, IV, 24 f.; *Einleit.*, in *die apok. Schriften*, 419; Vatke; Delitzsch, *De Habacuci*, 50; Zöckler, Bissell, Ball, Rothstein, etc.) hold that the original language was Heb. The evidence, which is weak, is as follows: (a) The style is Hebraistic throughout (not more so than in writings known to have been composed in Alexandrian Gr; the idiom  $\kappa\alpha\tau\alpha\sigma\chi\upsilon\nu\epsilon\sigma\theta\alpha\iota + \acute{\alpha}\nu\omicron$ , *kataischúnesthai + apó* = בְּרִישׁ מִן, *bōsh min* [ver 44 EV; LXX ver 44], "to be ashamed of," occurs in parts of the LXX which are certainly not tr<sup>s</sup>). (b) The three Heb martyrs bear Heb names (ver 66 EV). This only shows that the *tale* is of Heb origin. (2) Most modern non-Romanist scholars hold that the original language of the Song (and Prayer) was Gr. So Keil, Fritzsche, De Wette, Schürer, König, Cornill, Strack, etc.

Some grounds: (1) The Hebraisms are comparatively few, and those which do exist can be paralleled in other writings composed in Hellenistic Gr. (2) It can be proved that in Dnl and also in Bel (see Intro to Bel in the *Oxford Apoc.* ed. R. H. Charles), Theodotion corrects the LXX from the Heb (lost in the case of Bel); but in Three, Theodotion corrects according to Gr idiom or grammar. It must be admitted, however, that the evidence is not very decisive either way.

As to the text and the various versions of the Song, see what is said in art. BEL AND THE DRAGON. It is important to note that the tr<sup>s</sup> in 6. Text and EV are made from Theodotion's Gr version, which occurs in ancient VSS of the LXX (A B V Q <sup>de</sup>) instead of the true LXX (Cod. 87).

LITERATURE.—See art. BEL AND THE DRAGON; Marshall (*HDB*, IV, 754); W. H. Bennett (*Oxford Apoc.* ed. R. H. Charles, 625 ff).

T. WITTON DAVIES  
SONS OF DEGREES. See DEGREES, SONS OF; DIAL OF AHAZ, 7.

SONS OF. See SON, SONS.

SONS OF GOD (OT) בְּנֵי הָאֱלֹהִים, *bēnē hā-'ēlōhīm*, "sons of God" [Gen 6 2, 4; Job 1 6; 2 1]; אֱלֹהִים בְּנֵי אֱלֹהִים, *bēnē 'ēlōhīm*, "sons of God" [Job 38 7]; אֱלֹהִים בְּנֵי אֱלֹהִים, *bēnē 'ēlīm*, "ye mighty," AV; "ye sons of the mighty," AVm, RV; "sons of God" or "sons of the gods," RVm [Ps 29 1]; "sons of the mighty," AV and RV; "sons of God" or "sons of the gods," RVm [Ps 89 6 (Heb 7)]; LXX  $\nu\iota\omicron\iota\ \tau\omicron\upsilon\ \theta\epsilon\omicron\upsilon$ , *huiōi tou theou*, οἱ ἄγγελοι τοῦ θεοῦ, *hoi ἄγγελοι τοῦ θεοῦ* [Gen 6 2];  $\nu\iota\omicron\iota\ \tau\omicron\upsilon\ \theta\epsilon\omicron\upsilon$ , *huiōi tou theou* [Gen 6 4]; οἱ ἄγγελοι τοῦ θεοῦ, *hoi ἄγγελοι τοῦ θεοῦ* [Job 1 6; 2 1]; ἄγγελοι μου, *ἄγγελοι μου* [Job 38 7];  $\nu\iota\omicron\iota\ \theta\epsilon\omicron\upsilon$ , *huiōi theou* [Ps 29 1; 89 6; cf Dnl 3 25] ]:

This article will deal with this phrase as it is used in the above passages. In the passages from Job and Pss it is applied to supernatural beings or angels. In Job the "sons of God" are represented as appearing before the throne of Jeh in heaven, ready to do Him service, and as shouting for joy at the creation of the earth. In the Pss they are summoned to celebrate the glory of Jeh, for there is none among them to be compared to Him. The phrase in these passages has no physical or moral reference. These heavenly beings are called "sons of God" or "sons of the 'ēlōhīm" simply as belonging to the same class or guild as the 'ēlōhīm, just as "sons of the prophets" denotes those who belong to the prophetic order (see A. B. Davidson, *Comm.* on Job 1 6).

Different views, however, are taken of the passage in Gen 6 2, 4: "The sons of God saw the daughters of men that they were fair; and they took them wives of all that they chose. . . . The Nephilim were in the earth in those days, and also after that, when the sons of God came in unto the daughters of men." See GIANTS; NEPHILIM.

(1) "Sons of God" is interpreted as referring to men. (a) to sons of the nobles, who married daughters of the common people. This is the view of many Jewish authorities, who hold that it is justified by the use of 'ēlōhīm in the sense of "judges" (Ex 21 6; 22 8 f, etc). But this cannot be the meaning of 'ēlōhīm here, for when 'adhām, "men," is used to denote the lower classes, it is contrasted with 'ish, as in Ps 49 2 (Heb 3), not with 'ēlōhīm. When contrasted with 'ēlōhīm it signifies the human race. (b) Some commentators hold that by "sons of God" is to be understood the pious race descended from Seth, and by "daughters of men" the daughters of worldly men. These commentators connect the passage with Gen 4 25 f, where the race of Seth is characterized as the worshippers of Jeh and is designated as a whole, a seed (of Dt 14 1; 32 5; Hos 1 10 [Heb 2 1]). They consider the restricted meaning they put upon "men" as warranted by the contrast (of Jer 32 20; Isa 43 4), and that as the term "daughters" expresses actual descent, it is natural to understand "sons" in a similar sense. The phrase "took wives," they contend also, supports the ethical view, being always used to signify real and lasting marriages, and cannot, therefore, be applied to the higher spirits in their unholy desire after flesh. On this view vs 1-4 are an introduction to the reason for the Flood, the great wickedness of man upon the earth (ver 5). It is held that nothing is said in ver 4 of a race of giants springing from the union of angels with human wives (see paragraph 2, below), and that the violence which is mentioned along with the corruption of the world (ver 11) refers to the sin of the giants.

(2) Most scholars now reject this view and interpret "sons of God" as referring to supernatural beings in accordance with the meaning of the expression in the other passages. They hold that Dt 14 1, etc, cannot be regarded as supporting the ethical interpretation of the phrase in a historical narrative. The reference to Jer 32 20, etc, too, is considered irrelevant, the contrast in these passages being between Israel and other nations, not, as here, between men and God. Nor can a narrower signification (daughters of worldly men) be attached to "men" in ver 2 than to "men" in ver 1, where the reference is to the human race in general. This passage (Gen 6 1-4), therefore, which is the only one of its kind, is considered to be out of its place and to have been inserted here by the compiler as an introduction to the story of the Flood (vs 5-8). The intention of the original writer, however, was to account for the rise of the giant race of antiquity by the union of demigods with human wives. This interpretation accords with En chs 6-7, etc, and with Jude vs 6 f, where the unnatural sin of the men of Sodom who went after "strange flesh" is compared with that of the angels (cf 2 Pet 2 4 ff). (See Hävernick, *Intro to the Pent*; Hengstenberg on the *Pent*, I, 325; Oehler, *OT Theology*, I, 196 f; Schultz, *OT Theology*, I, 114 ff; *Comms. on Gen* by Delitzsch, Dillmann, and Driver.) But see ANTE-DILUVIANS, 3; CHILDREN OF GOD; GIANTS; NEPHILIM; REPHAIM.

JAMES CRICHTON  
SONS OF GOD (NT): Two Gr words are tr<sup>d</sup> "son," τέκνον, *téknon*, *vlós*, *huiós*, both words indicating sonship by parentage, the former indicating that the sonship has taken place by physical descent, while the latter presents sonship more from the legal side than from the standpoint of relationship. John, who lays special emphasis on sonship by birth, uses *téknon*, while Paul, in emphasizing sonship from the legal side, as referring to adoption, which was current among the Romans but scarcely if at all known, to, or if known, practised by, the Jews, uses the word *huiós* (Jn 1 12; Rom 8 14.16.19; Gal 4 6.7; 1 Jn 3 1.2).

Men are not by nature the sons of God, at least not in the sense in which believers in Christ are so called. By nature those outside of Jesus Christ are "children of wrath" (Eph 2 3), "of disobedience" (2 2), controlled not by the Spirit of God (Rom 8 14), but by the spirit of disobedience

(Eph 2 2-4). Men become sons of God in the regenerative and adoptive sense by the acceptance of Jesus Christ as Lord and Saviour (Jn 1 12 f; Gal 3 26). The universal brotherhood which the NT teaches is that brotherhood which is based on faith in the Lord Jesus Christ as the Divine and only Saviour of the world. And the same is true of the universal Fatherhood of God. It is true that all men are "his offspring" (Acts 17 28 f) in the sense that they are God's created children; but that the NT makes a very clear and striking distinction between sonship by virtue of creation and sonship by faith in the Lord Jesus Christ, there can be no reasonable doubt.

Sonship is the present possession of the believer in Christ (1 Jn 3 2). It will be completed at the second coming of Our Lord (Rom 8 23), at which time the believer will throw off his incognito, by reason of which the world may not have recognized his sonship (1 Jn 3 1.2), and be fully and gloriously revealed as the son of God (2 Cor 5 10). It doth not yet appear, it hath not yet appeared, what we shall be; the revelation of the sons of God is reserved for a coming day of manifestation.

The blessings of sonship are too numerous to mention, save in the briefest way. His sons are objects of God's peculiar love (Jn 17 23), and His Fatherly care (Lk 12 27-33). They have the family name (Eph 3 14 f; 1 Jn 3 1); the family likeness (Rom 8 29); family love (Jn 13 35; 1 Jn 3 14); a filial spirit (Rom 8 15; Gal 4 6); a family service (Jn 14 23 f; 15 8). They receive fatherly chastisement (He 12 5-11); fatherly comfort (2 Cor 1 4), and an inheritance (Rom 8 17; 1 Pet 1 3-5).

Among the evidences of sonship are: being led by the Spirit (Rom 8 14; Gal 5 18); having a child-like confidence in God (Gal 4 5); having liberty of access (Eph 3 12); having love for the brethren (1 Jn 2 9-11; 5 1), and obedience (1 Jn 5 1-3).

WILLIAM EVANS

**SOOTHSAYERS**, sōōth'sā-ēr-z. See **ASTROLOGY**, 1; **DIVINATION**.

**SOP**, sop (ψωμίον, *psōmion*): A thin, wafer-like piece of bread dipped into the common dish as a sort of improvised spoon, is thus designated in Jn 13 26 ff. See **MORSEL**.

**SOPATER**, sō'pa-tēr, sop'a-tēr (Σόπατρος, *Sōpatros*): RV the son of Pyrrhus; AV omits. A man of Beroea who is mentioned with some Thessalonians and others as accompanying Paul as far as Asia on his return to Jerus after his 3d missionary journey (Acts 20 4). He is probably the same as the "Sospater" of Rom 16 21.

**SOPE**, sōp. See **SOAP**.

**SOPHEREETH**, sō-fē'reth, sof'ē-reth, sō'fē-reth (שֹׁפְרֵת, *šōphereth*): One of the remnant returning from captivity (Ezr 2 55 AV; Neh 7 57). In RV of Ezr 2 55 it is "Hassophereth," the def. art. being transliterated.

**SOPHONIAS**, sof-ō-ni'as (LXX Σοφονίας, *Sophonias*): The form in AV and RV of 2 Esd 1 40 for Zephaniah the prophet.

**SORCERER**, sōr'sēr-ēr, **SORCERY**, sōr'sēr-i. See **ASTROLOGY**, 1; **DIVINATION**; **MAGIC**; **WITCH-CRAFT**.

**SORE**, sōr (substantive) (שָׂרָה, *negha'*; ἔλκος, *hēlkos*, vb. ἑλκίζομαι, *hēlkozōmai*): In the account of the appearance of leprosy (Lev 13 42 f) the spot on the skin is called by this name, which in AV is tr'd

"sore," but in RV "plague"; similarly in the Dedication Prayer (2 Ch 6 28 f) RV has altered the rendering of *negha'* for "sore" to "plague" as it has done also in Ps 38 11. The word literally means a "stroke" or "blow," and so is applied to a disease or infliction from God. מַקְהָה טְרִיָּאָה, *makkāh ṭrīyāh*, in AV is rendered "putrifying sores," ERV "fester-ing sores," ARV and ERVm "fresh stripes." See **STRIPES**. In the only other text in the OT in which "sore" is used as a substantive in AV (Ps 77 2), the word used is *yādāh*, which lit. means the "outstretched hand," hence RV renders the text: "My hand was stretched out in the night and slacked not." In the NT the ulcers on the limbs of Lazarus which were the result of poverty and hardship (Lk 16 20), and were licked by the pariah dogs (ver 21), are called "sores." Sores also which are called noisome and grievous, were the result of the outpouring of the first of the seven bowls of the wrath of God (Rev 16 2-11).

ALEX. MACALISTER

**SOREK**, sō'rek, **VALLEY OF** (נַחַל שׁוֹרֵק, *nahal sōrēk*, "the valley of the choice [*sōrēk*] vine" [see **VINE**]; σωρήχ, *sōrēch*): "[Samson] loved a woman in the valley of Sorek, whose name was Delilah" (Jgs 16 4). Jerome (*OS*, 153 f, 6) mentions a Capharsorec which was near Saraa (ancient **ZORAH** [q.v.]); this latter is undoubtedly the village of *Sura'h*, high up upon the northern slopes of the great *Wādy es Surār*. About ¼ of a mile W. of this is *Khurbet Sūrīk*, which is certainly the site referred to by Jerome, and possibly marks that of a more ancient town which gave its name to the whole valley. This valley is of importance in the historical geography of Pal out of all proportion to its scanty mention in the OT (*HGHL*, 218 ff). The *Wādy es Surār* is an expansion of the ravine *Wādy Isma'īn* (which itself is formed by the junction of the great *Wādy Beit Hanūneh*, which rises near *Bereh*, and the *Wādy es Sikkēh*, which drains the "Plain of Rephaim" near Jerus). The Jerus-Jaffa Railway traverses successively the *Wādy es Surār*, the *Wādy Isma'īn* and the *Wādy es Sikkēh* to reach the Jerus plateau. The Valley of Sorek is a name which probably belonged only to the open, fertile valley, well suited for vineyards, which traverses the Shephelah. It is now given over almost entirely to the cultivation of wheat, barley and maize (*durra*). The valley passes between the lofty hill of *Sara'h* (Zorah) to the N. and *Ain Shems* (Beth-shemesh) and *Tibneh* (Timnah) on the S. Standing on the ruins of Beth-shemesh, one can watch the modern railway train winding for miles up the valley along almost the very road from *Ekron* (now *Akiv*), upon which came the strange sight of the milch kine dragging the ark (1 S 6 12). Very probably it was in this valley that the Philis were defeated (1 S 7 5-14) (*PĒF*, III, 53, Sh XVII).

E. W. G. MASTERMAN

**SORREL**, sor'el: RV in Zec 1 8 for "speckled." See **COLORS**.

**SORROW**, sor'ō (מַכְהָה, *hēbhel*, יָגוֹן, *yāghōn*, מַכְהָה, *makk'hōh*, etc; λύπη, *lūpē*): The OT has very many words tr'd "sorrow," those named being the most frequent; in the NT "sorrow" is usually the tr of *lūpē* (Lk 22 45; Jn 16 6; 2 Cor 2 3.7, etc). *Pénthos*, tr'd "sorrow" in Rev 18 7; 21 4, is in RV "mourning." *Odūnē*, of pain and distress, is thus rendered in Rom 9 2; 1 Tim 6 10 (of the vb. in Lk 2 48; Acts 20 38). RV frequently gives a more literal rendering of the words used, as "toil" (Gen 3 17), "pangs" (Ex 15 14), "pining" (Dt 28 65), "distress" (Isa 5 30), "lamentation" (Isa 29 2), etc; sometimes also it uses "sorrow" for other

words, as for "grief" (2 Ch 6 29; Ps 31 10; 69 26; etc; 2 Cor 2 5), "heaviness" (Rom 9 2; 2 Cor 2 1).

Sorrow or grief is necessary for discipline, for the development of the finer feelings and higher nature of the soul and spirit (Ecl 7 3, "Sorrow is better than laughter; for by the sadness of the countenance the heart is made glad," m "better"). Sorrow inevitably follows sin, and is its punishment, yet the righteous are not exempt from it. The "Servant of Jeh" was "a man of sorrows" (Isa 53 3). Christians learn how to be "sorrowful, yet always rejoicing" (2 Cor 6 10; 7 4; Col 1 24; 1 Thess 1 6; etc). In the New Jerus it is predicted that there shall be no sorrow, for sorrow shall have done its work, and the first things have passed away (Rev 21 4).

W. L. WALKER

**SOSIPATER**, sō-sip'a-tēr (Σωσίπατρος, *Sōsipatros*): Sosipater unites with Lucius and Jason in sending greetings to the Rom Christians (Rom 16 21). He is a "kinsman" of Paul, by which Paul means a Jew (Rom 9 3; 16 11.21). It is the same name as SOPATER (q.v.). "Sopater of Beroea" was one of the companions of Paul on his journey from Philippi after his 3d missionary journey (Acts 20 4). These two are probably the same person, Paul having with him in Corinth, at the time of writing to the Rom Christians, the two Macedonians, Sopater of Beroea and Jason of Thessalonica. The name Sosipater is found on a list of politarchs of Thessalonica.

S. F. HUNTER

**SOSTHENES**, sōs'the-nēz (Σωσθένης, *Sōsthēnēs*): Chief of the synagogue at Corinth (Acts 18 17). Possibly identical with the co-worker (afterward) of Paul mentioned in 1 Cor 1 1.

**SOSTRATUS**, sōs'tra-tus (Σώστρατος, *Sōstratos*, in V Σοσ-, *Sos-*): "The governor of the citadel" of Jerus under Antiochus IV (Epiphanes). His duty was to gather the revenues of the city and province for the imperial treasury. He made a new departure in demanding from Menelaus direct the sum promised to the king in 2 Macc 4 27 ff (for Jason had the privilege of sending the money by his own messenger to the king [2 Macc 4 23]). This claim the usurper Menelaus disputed; consequently he and the governor were both summoned to appear before the king. No more is told, and Sostratus is otherwise unknown.

S. ANGUS

**SOTAI**, sō'tī, sō'tā-ī, sō-tā-ī (שׂוֹטַי, *šōṭay*): One of those who returned from captivity, being descendants of Solomon's servants (Ezr 2 55; Neh 7 57).

**SOTTISH**, sot'ish (שׂוֹטִים, *šākhāl*, "thick-headed"): "They are sottish [stupid, very foolish] children" (Jer 4 22).

**SOUL**, sōl (שׁוּל, *nephesh*; ψυχή, *psuchē*; Lat *anima*):

(1) Soul, like spirit, has various shades of meaning in the OT, which may be summarized as follows:

**1. Shades of Meaning** "person," "desire," "appetite," "emotion" and "passion" (*BDB*, s.v.). In the first instance it meant that which breathes, and as such is distinguished from *bāsār*, "flesh" (Isa 10 18; Dt 12 23); from *sh'er*, "the inner flesh," next the bones (Prov 11 17, "his own flesh"); from *belen*, "belly" (Ps 31 10, "My soul and my belly are consumed with grief"), etc.

(2) As the *life-breath*, it departs at death (Gen 35 18; Jer 15 2). Hence the desire among OT

saints to be delivered from Sheol (Ps 16 10, "Thou wilt not leave my soul to Sheol") and from *shahath*, "the pit" (Job 33 18, "He keepeth back his soul from the pit"; Isa 38 17, "Thou hast . . . delivered it [my soul] from the pit of corruption").

(3) By an easy transition the word comes to stand for the *individual, personal life*, the *person*, with two distinct shades of meaning which might best be indicated by the Lat *anima* and *animus*. As *anima*, "soul," the life inherent in the body, the animating principle in the blood is denoted (cf Dt 12 23.24, "Only be sure that thou eat not the blood: for the blood is the soul; and thou shalt not eat the soul with the flesh"). As *animus*, "mind," the center of our mental activities and passivities is indicated. Thus we read of 'a hungry soul' (Ps 107 9), 'a weary soul' (Jer 31 25), 'a loathing soul' (Lev 26 11), 'a thirsty soul' (Ps 42 2), 'a grieved soul' (Job 30 25), 'a loving soul' (Cant 1 7), and many kindred expressions. Cremer has characterized this use of the word in a sentence: "*Nephesh* [soul] in man is the subject of personal life, whereof *pneuma* or *rūh* [spirit] is the principle" (*Lexicon*, s.v., 795).

(4) This individuality of man, however, may be denoted by *pneuma* as well, but with a distinction. *Nephesh* or "soul" can only denote the individual life with a material organization or body. *Pneuma* or "spirit" is not so restricted. Scripture speaks of "spirits of just men made perfect" (He 12 23), where there can be no thought of a material or physical or corporeal organization. They are "spiritual beings freed from the assaults and defilements of the flesh" (Delitzsch, in loc.). For an exceptional use of *psuchē* in the same sense see Rev 6 9; 20 4, and (irrespective of the meaning of Ps 16 10) Acts 2 27.

(1) In the NT *psuchē* appears under more or less similar conditions as in the OT. The contrast here is as carefully maintained as there. It is used where *pneuma* would be out of place; and yet it seems at times to be employed where *pneuma* might have been substituted. Thus in Jn 19 30 we read: "Jesus gave up his *pneuma*" to the Father, and, in the same Gospel (Jn 10 15), Jesus gave up His "*psuchē* for the sheep," and in Mt 20 28 He gave His *psuchē* (not His *pneuma*) as a ransom—a difference which is characteristic. For the *pneuma* stands in quite a different relation to God from the *psuchē*. The "spirit" (*pneuma*) is the outbreathing of God into the creature, the life-principle derived from God. The "soul" (*psuchē*) is man's individual possession, that which distinguishes one man from another and from inanimate nature. The *pneuma* of Christ was surrendered to the Father in death; His *psuchē* was surrendered, His individual life was given "a ransom for many." His life "was given for the sheep."

(2) This explains those expressions in the NT which bear on the salvation of the soul and its preservation in the regions of the dead. "Thou wilt not leave my soul unto Hades" (the world of shades) (Acts 2 27); "Tribulation and anguish, upon every soul of man that worketh evil" (Rom 2 9); "We are . . . of them that have faith unto the saving of the soul" (He 10 39); "Receive . . . the implanted word, which is able to save your souls" (Jas 1 21).

The same or similar expressions may be met with in the OT in reference to the soul. Thus in Ps 49 8, AV "The redemption of their soul is precious," and again: "God will redeem my soul from the power of Sheol" (Ps 49 15). Perhaps this may explain—at least this is Wendt's explanation—why even a corpse is called *nephesh* or soul in the OT, because, in the region of the dead, the individuality

is retained and, in a measure, separated from God (cf Hag 2 13; Lev 21 11).

The distinction between *psuchē* and *pneuma*, or *nephesh* and *rūh*, to which reference has been made, may best be described in the words of

**3. Oehler** Oehler (*OT Theology*, I, 217): "Man on Soul and is not spirit, but has it: he is soul. Spirit . . . In the soul, which sprang from

the spirit, and exists continually through it, lies the individuality—in the case of man, his personality, his self, his *ego*." He draws attention to the words of Elihu in Job (33 4): "God's spirit made me, the soul called into being; and the breath of the Almighty animates me," the soul kept in energy and strength, in continued existence, by the Almighty, into whose hands the inbreathed spirit is surrendered, when the soul departs or is taken from us (1 K 19 4). Hence according to Oehler the phrases *naphshī* ("my soul"), *naphsh'khā* ("thy soul") may be rendered in Lat *egomet, tu ipse*; but not *rūhī* ("my spirit"), *ruhākhā* ("thy spirit")—soul standing for the whole person, as in Gen 12 5; 17 14; Ezk 18 4, etc. See PSYCHOLOGY. J. I. MARAIS

**SOUND**, sound: In Isa 63 15 AV has "the sounding of thy bowels," a painfully literal tr of *hāmōn mē'eykhā*, with the similar phrase, "my bowels shall sound like an harp," in 16 11 (cf Jer 48 36). The intestines were considered a seat of emotion, and at times of great excitement were thought (in poetry, at least) to become tense and to give forth a musical sound. RV (following AV in Jer 48 36) substitutes "heart" for "bowels" in Isa 16 11, thus obscuring the figure but preserving the sense. In Isa 63 15 RV paraphrases "the yearning of thy heart" (ERV "bowels"), a needless change from 16 11. See also BATH KOL; SOLEMN, SOLEMNITY. BURTON SCOTT EASTON

**SOUNDINGS**, sound'ingz. See SHIPS AND BOATS, III, 2.

**SOUR**, sour: (1) בָּטָר, *bōṣer*, "immature," "unripe": "The fathers have eaten sour grapes" (Jer 31 29f; Ezk 18 2; cf Isa 18 5 AV). (2) סָר, *ṣūr*, "to turn aside," "degenerate": "Their drink is turned sour" (AVm "gone," RVm "Their carouse is over").

**SOUTH**, south: (1) נֶגֶב, *neghebb*, according to BDB from נָגַב, *nāghabh*, meaning "to be dry," the word oftenest used, in RV capitalized (South) in those places where it seems to denote a particular region, i.e. to the S. of Judah. (2) יָמִינִי, *yāmīn*, "right hand," "right." The derived meaning, "south," seems to imply an eastern posture in prayer in which the right hand is toward the S.; cf Arab. يَمِين, *yamīn*, "right," and يَمَن, *yemen*, "Yemen," a region in Southwestern Arabia. (3) תְּמָנָה, *tēmān*, from the same root as (2), is often used for the south; also for the south wind (Ps 78 26; Cant 4 16). (4) יָם, *yām*, lit. "sea" (Ps 107 3). (5) דְּרוֹם, *dārōm*, etymology doubtful (Dt 33 23; Ezk 40 24). (6) מִדְּבָר, *midhbār*, lit. "desert" (Ps 75 6, reading doubtful).

(7) לֵפֶס, *lēps*, "south west wind" (Acts 27 12). (8) μεσημβρία, *mesēmbria*, lit. "mid-day"; "south" (Acts 8 26); "noon" (22 6). (9) νότος, *nótos*, "south wind" (Lk 12 55; Acts 27 13; 28 13); "south" (1 Macc 3 57; Mt 12 42; Lk 11 31; 13 29; Rev 21 13).

The south wind is often referred to: see Cant 4 16; Job 37 9 (cf 9 9); Zec 9 14 (cf Isa 21 1); Lk 12 55.

Of the passages where South (*neghebb*) clearly refers to a particular region between Pal and Sinai see: "And Abraham journeyed, going on still toward the South" (*neghbāh*) (Gen 12 9; 13 1; Dt 1 7). We read of "the South of the Jerahmeelites," "the South of the Kenites" (1 S 27 10); "the South of the Cherethites," "the South of Caleb" (1 S 30 14); "the South of Judah" (2 Ch 28 18); "Ramoth of the South" (1 S 30 27).

In Ps 126 4, "Turn again our captivity, O Jeh, as the streams in the South," we have a figurative reference to the fact that, after a long period of drought, the dry watercourses are finally filled with rushing streams. The reference in Ezk 20 46 f to "the forest of the South" is to a condition of things very different from that which exists today, though the region is not incapable of supporting trees if they are only planted and protected.

ALFRED ELY DAY

**SOUTH, CHAMBERS OF THE**: The twelve constellations of the Zodiac. See ASTRONOMY, II, 12.

**SOUTH, QUEEN OF THE** (Mt 12 42). See QUEEN OF SHEBA.

**SOUTH RAMOTH**. See RAMOTH.

**SOUTHEAST**. See NORTHEAST.

**SOW**, sou. See SWINE.

**SOWER**, sō'ēr, **SOWING**, sō'ing. See AGRICULTURE.

**SPAIN**, spān (Σπασία, *Spania*): The country in the S.W. of Europe which still bears this name. It was Paul's purpose, as stated in Rom 15 24.28, to visit Spain. If, as is probable, he ultimately carried out this intention, it must have been after a release from his first imprisonment. Clement of Rome speaks of the apostle as having reached "the extreme limit of the W." (*Ep. of Clem.*, v). See PAUL, THE APOSTLE; TARSHISH.

**SPAN** (זֶרֶת, *zereth*; σπιθαμή, *spithamē*): A measure of length equal to half a cubit or about 9 in. (Ex 28 16; 39 9; 1 S 17 4, etc.) Lam 2 20 AV is a mistranslation; see RV. See WEIGHTS AND MEASURES.

**SPARK**, spārk. See LEVIATHAN.

**SPARROW**, spar'ō (צִפּוֹרִים, *ṣippōr*; στρούθιον, *strouthion*; Lat *passer*): A small bird of the *Fringillidae* family. The Heb *ṣippōr* seems to have been a generic name under which were placed all small birds that frequented houses and gardens. The word occurs about 40 t in the Bible, and is indiscriminately tr'd "bird," "fowl" or "sparrow." Our translators have used the word "sparrow" where they felt that this bird best filled the requirements of the texts. Sparrows are small brown and gray birds of friendly habit that swarm over the northern part of Pal, and W. of the Sea of Galilee, where the hills, plains and fertile fields are scattered over with villages. They build in the vineyards, orchards and bushes of the walled gardens surrounding houses, on the ground or in nooks and crannies of vine-covered walls. They live on seeds, small green buds and tiny insects and worms. Some members of the family sing musically; all are great chatterers when about the business of life. Repeatedly they are mentioned by Bible writers, but most of the references lose force as applying to the bird family, because they are tr'd "bird."

or "fowl." In a few instances the word "sparrow" is used, and in some of these, painstaking commentators feel that what is said does not apply to the sparrow. For example see Ps 102 7:

"I watch, and am become like a sparrow  
That is alone upon the housetop."

The feeling that this is not characteristic of the sparrow arises from the fact that it is such a friendly

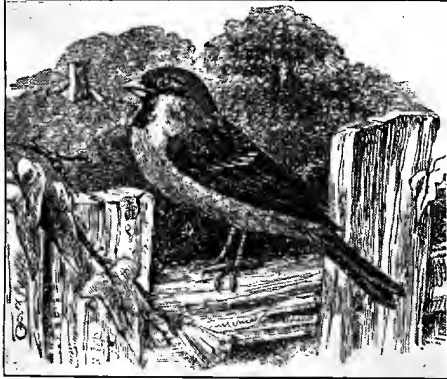

Sparrow (*Fringilla domestica*).

bird that if it were on the housetop it would be surrounded by half a dozen of its kind; so it has been suggested that a solitary thrush was intended. There is little force in the change. Thrushes of today are shy, timid birds of thickets and deep undergrowth. Occasionally a stray one comes around a house at migration, but once settled to the business of living they are the last and most infrequent bird to appear near the haunts of man. And bird habits do not change in one or two thousand years. In an overwhelmed hour the Psalmist poured out his heart before the Almighty. The reason he said he was like a "sparrow that is alone upon the housetop" was because it is the most unusual thing in the world for a sparrow to sit mourning alone, and therefore it attracted attention and made a forceful comparison. It only happens when the bird's mate has been killed or its nest and young destroyed, and this most cheerful of birds sitting solitary and dejected made a deep impression on the Psalmist who, when his hour of trouble came, said he was like the mourning sparrow—alone on the housetop. Another exquisite song describes the bird in its secure and happy hour:

"Yea, the sparrow hath found her a house,  
And the swallow a nest for herself, where she may  
lay her young,  
Even thine altars, O Jeh of hosts,  
My King, and my God" (Ps 84 3).

When the mind of man was young and he looked on the commonest acts of creatures around him as filled with mystery, miracle and sign—he held in superstitious reverence any bird that built on a temple, because he thought it meant that the bird thus building claimed the protection of God in so doing. For these reasons all temple builders were so revered that authentic instances are given of people being put to death, if they disturbed temple nests or builders. Because he noticed the sparrow in joyful conditions is good reason why the Psalmist should have been attracted by its mourning. There is a reference to the widespread distribution of these birds in Prov 26 2:

"As the sparrow in her wandering, as the swallow  
in her flying,  
So the curse that is causeless alighteth not."

Once settled in a location, no bird clings more

faithfully to its nest and young, so this "wandering" could only mean that they scatter widely in choosing locations. Mt 10 29: "Are not two sparrows sold for a penny? and not one of them shall fall on the ground without your Father." This is a reference to the common custom in the East of catching small birds, and selling them to be skinned, roasted and sold as tid-bits—a bird to a mouthful. These lines no doubt are the origin of the oft-quoted phrase, "He marks the fall of the sparrow." Then in ver 31 comes this comforting assurance: "Fear not therefore; ye are of more value than many sparrows." Lk 12 6: "Are not five sparrows sold for two pence? and not one of them is forgotten in the sight of God." This affirms the implication of Mark that these tiny birds were an article of commerce in the days of Jesus, just as they are now in the Far East. GENE STRATTON-PORTER

**SPARTA**, spär'ta, **SPARTANS**, spär'tanz (Σπάρτη, *Spártē* [1 Macc 14 16], Σπαρτιῶται, *Spartitiōtai*; Lacedaemonians [AV 1 Macc 12 2.5.6.10. 21; 14 20-23; 15 23; in 2 Macc 5 9, Gr *Lakedaimōniōi*]): The passages in 1 Macc relate to a correspondence initiated by Jonathan, the priest, during the Maccabean revolt, and continued after his death with his brother Simon, between the Jews and the Lacedaemonians or Spartans, with a view to a friendly alliance. The proposals, curiously based on a claim to kindredship, were favorably received by the Lacedaemonians. See the letters (1 Macc 12 5 ff. 19 ff; 14 16 ff). The claim to blood-relationship (cf 1 Macc 12 21; 2 Macc 5 9) is of course absurd, but there is no good reason to doubt the genuineness of the transaction described. See **ARIUS**; **ASMONEANS**; **LACEDAEMONIANS**; **MACCABEANS**, etc. JAMES ORR

**SPEAKING**, spē'king, **EVIL**. See **EVIL-SPEAKING**; **SLANDER**.

**SPEAR**, spēr, **SPEARMEN**, spēr'men. See **ARMOR**, III, 4; **ARMY**, 7.

**SPECIALLY**, spesh'al-i (מְשַׁלֵּי, *m'ōdh* [Ps 31 11 AV]; μάλιστα, *mālista*): Used in an emphatic sense; derived from a superlative. While usually employed for emphasis, it carries with it slightly the idea of something additional. Not used in the OT in RV, the sense of the Heb being expressed more clearly by "exceedingly," "very." Its ordinary NT usage is, "mostly," "particularly," "chiefly" or, "most of all." Paul in his practical exhortations says: "But if any provideth not for his own, and specially his own household, he hath denied the faith" (1 Tim 5 8; cf Gal 6 10; 1 Tim 4 10).

WALTER G. CLIPPINGER  
See **COLORS**; **HYENA**.

**SPECTACLE**, spek'ta-k'l (θέατρον, *théatron*): Occurs twice in the NT: (1) of the place where assemblies or exhibitions were held (Acts 19 29, "theatre"); (2) figuratively of the suffering apostles (1 Cor 4 9).

**SPEECH**, spēch (דַּבָּר, *'imrāh*, דְּבַר, *dābhār*, etc; λόγος, *lógos*): "Speech," the articulate utterance of thought, is the tr of various Heb terms which convey this idea of "saying" or "word"; so, in the NT, the term generally so rendered is *logos*, "word." See **LOGOS**; **WORD**. *Eulogia* in Rom 16 18 is "fair speech"; *lalia* in Mt 26 73; Mk 14 70 AV; Jn 8 43 is simply "talk." RV has "speech" for various other words in AV, as "matters" (1 S 16 18, m "business"), "communication" (Mt 5 37;

Eph 4 29), "words" (Lk 20 20; 1 Cor 14 9); "persuasiveness of speech" for "enticing words" (Col 2 4), etc. W. L. WALKER

**SPELT**, spelt (סְפֵלְתָא, *kussemeth*; ὄλυρα, *ólura*, ζέα, *zóa* [Ex 9 32, AV "rye"; Isa 28 25, AV "rye," m "spelt"; Ezk 4 9, AV "fitches," m "spelt"; RV adopts "spelt," influenced by LXX, in all passages]: Spelt is the seed of *Triticum spelta*, a kind of wild wheat. Several writers would identify this *kussemeth* with the Arab. *kirsemeḥ* (*Vicia ervilia*), a kind of vetch much used as camels' fodder.

**SPICE**, spís, **SPICES**, spí'sis, -sez:

(1) (בְּשֵׂם, *besem* [Ex 30 23], בִּשְׂמִים, *bōsem*, pl. בְּשַׁמִּים, *b'sāmim*, all from root "to attract by desire," esp. by smell): The list of spices in Ex 30 23 includes myrrh, cinnamon, "sweet calamus and cassia." These, mixed with olive oil, made the "holy anointing oil." Officials of the temple had charge of the spices (1 Ch 9 29). Among the treasures of the temple shown by Hezekiah to the messengers of Babylon were the spices (2 K 20 13). They were used in the obsequies of kings (2 Ch 16 14) and in preparation of a bride for a royal marriage (Est 2 12, "sweet-odors" = balsam). Spices are frequently mentioned in Cant (4 10.14.16; 5 1, m and AV "balsam"; 5 13; 6 2, "bed of spices," m "balsam"; 8 14). These passages in Cant may refer in particular to balsam, the product of the balsam plant, *Balsamodendron opobalsamum*, a plant growing in Arabia. According to Jos it was cultivated at Jericho, the plant having been brought to Pal by the Queen of Sheba (*Ant*, VIII, vi, 6; see also XIV, iv, 1; XV, iv, 2; *BJ*, I, vi, 6). See MYRRH.

(2) (סַמִּים, *šammim* [Ex 30 34, "sweet spices"]): "Take unto thee sweet spices, stacte, and onycha, and galbanum; sweet spices with pure frankincense." It is a general term for fragrant substances finely powdered. Cf Arab. شَم, *shamm*, "a

smell" or "sense of smell"; generally tr<sup>d</sup> "sweet incense" (Ex 25 6; 30 7; 31 11; 35 8.15.28; 39 38; 40 27 [AV only]; Lev 4 7; 16 12; Nu 4 16; 2 Ch 2 4 [AV only]; 13 11). In Ex 37 29; 40 27; 2 Ch 2 4, we have קְטֹרֶת סַמִּים, *q'tōreth šammim*, "incense of sweet spices."

(3) (בְּכַתֵּר, *ne'khō'th*; θυμιάματα, *thumiámata* [Gen 37 25, "spicery," m "gum tragacanth or storax"; θυμίαμα, *thumiáma*, "incense" [43 11, "spicery"; some Gr versions and the Vulg have "storax"]): Storax is the dried gum of the beautiful *Styrax officinalis* (see POPLAR), which was used as incense—a different article from that now passing under that name. Tragacanth is the resinous gum of several species of milk vetch (N.O. *Leguminosae*), esp. of the *Astragalus gummifer*. LXX "incense" is probably the best tr.

(4) (רֵקֶחַ, *reḳah*, "spiced" wine [Cant 8 2]). See WINE.

(5) (ἀρωμα, *árōma*, "spices" [Mk 16 1, AV "sweet spices"; Lk 23 56; 24 1; Jn 19 40; in ver 39 defined as a mixture of aloes and myrrh]). See PERFUMES; BURIAL.

(6) (ἀμύμον, *ámōmon* [Rev 18 13], m "amomum"; AV "odours"): The Gr means "blameless," and it was apparently applied in classical times to any sweet and fine odor. In modern botany the name *Amomum* is given to a genus in the N.O. *Zingiberaceae*. The well-known cardamon seeds (*Amomum cardamomum*) and the *A. grana Paradisi* which yields the well-known "grains of Paradise," used as a stimulant, both belong to this genus. What was the substance indicated in Rev 18 13 is quite uncertain. E. W. G. MASTERMAN

**SPIDER**, spí'dér ([1] עֲכָבִישׁ, 'akkābhīsh; of Arab. عَنَكَبُوت, 'ankabūt, EV "spider"; LXX ἀράχνη, *aráchnē* [Job 8 14; Isa 59 5]; [2] שְׂמַמִּית, *s'māmīth*, "lizard," AV "spider"; LXX καλαβώτης, *kalabōtes* [Prov 30 28]): *S'māmīth* of Prov 30 28

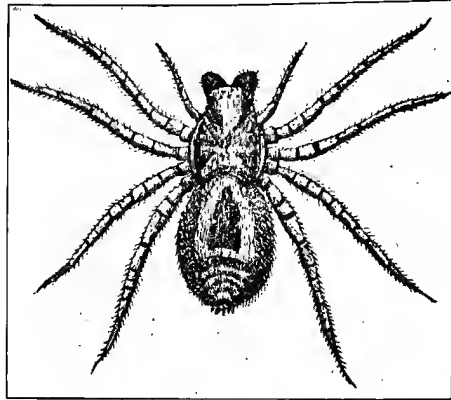

Spider (*Clubiona atroz*).

is probably the gecko, a kind of lizard, as LXX and RV have it. See LIZARD. In Job 8 14 the spider's web is an emblem of frailty: "Whose confidence shall break in sunder, and whose trust is a spider's web." Frailty or futility seems to be indicated also in Isa 59 5.6: "They hatch adders' eggs, and weave the spider's web: . . . Their webs shall not become garments, neither shall they cover themselves with their works." "Spider's web" is in Job 8 14 *bēth 'akkābhīsh*, "spider's house," while in Isa 59 5 it is *kūrē 'akkābhīsh*, קוּר, *kūr*, according to BDB, being "thread" or "film."

ALFRED ELY DAY

**SPIKENARD**, spik'nard (נֶרְדַּי, *nērd*; νάρδος,

*nárdos* [Cant 1 12; 4 14]; נֶרְדִּים, *ne'rdhīm*; νάρδοι, *nárdoi* [Cant 4 13], "spikenard plants"; νάρδος πιστιάκη, *nárdos pistiákē* [Mk 14 3; Jn 12 3], "pure nard," m "liquid nard"; the Eng. word is for "spiked nard," which comes from the *Nardus spicatus* of the Vulg): Spikenard is the plant *Nardostachys jatamansi* (N.O. *Valerianaceae*); in Arab. the name *Sunbul hind*, "Indian spike," refers, like the Eng. and Lat name, to the "spike"-like shape of the plant from which the perfume comes. The dried plant as sold consists of the "withered stalks and ribs of leaves cohering in a bundle of yellowish-brown capillary fibres and consisting of a spike about the size of a small finger" (Sir W. Jones, *As. Res.*, II, 409); in appearance the whole

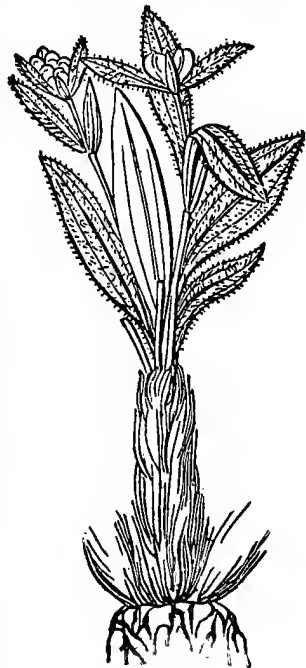

Nard.

plant is said to look like the tail of an ermine. It grows in the Himalayas. The extracted perfume is an oil, which was used by the Romans for anointing the head. Its great costliness is mentioned by Pliny.

With regard to the exact meaning of the *πιστική*, *psistikē*, in the NT, there is much difference of opinion: "pure" and "liquid" are both given in m, but it has also been suggested among other things that this was a local name, that it comes from the Lat *spicita* or from *pisitā*, the Sanskrit name of the spikenard plant. The question is an open one: either "genuine" or "pure" is favored by most commentators.

E. W. G. MASTERMAN

**SPINDLE**, spin'd'l. See SPINNING.

**SPINNING**, spin'ing: Although spinning must have been one of the commonest of the crafts in Bible times, it is mentioned definitely in three pas-

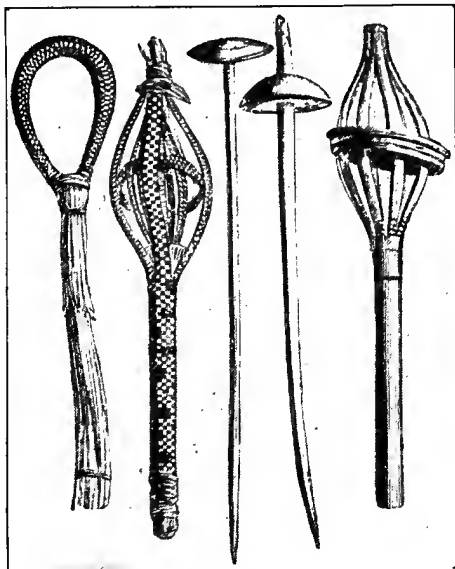

Spindles.

sages only, namely, Ex 35 25f, where *טַרְבֵּיחַ*, *tāwāh*, is so tr<sup>d</sup>, and in Mt 6 28; Lk 12 27 (*νήθειν*, *nēthein*), where Jesus refers to the lilies of the field as neither toiling nor spinning.

The materials commonly spun were flax, cotton, wool, goats' hair. Goats' hair required little preparation other than washing, before spinning. Wool was first cleansed and then carded. The present method of carding, which no doubt is of ancient origin, is to pile the wool on a mat and then detach the fibers from each other by snapping a bow-string against the pile. The bow is specially constructed and carefully balanced so that it can be easily held with one hand while with the other the string is struck with a pestle-shaped mallet like a carver's mallet. The same instrument is used for carding cotton.

Flax was treated anciently as today, if the Egypt sculptures have been rightly interpreted. The stalks after being stripped of their seeds were first retted. This operation consisted in soaking the stems in water until fermentation or rotting had so loosened the fibers that they could be separated from each other by combing. A series of washings and long exposure to the weather finally produced what was termed snowy-white linen.

The various fibers, mentioned above, to be made into thread, were gathered into a loose rope which was wound around a distaff or about the left hand. From this reel it was unwound as needed, the fibers more carefully adjusted with the thumbs and two first fingers of both hands, and then the rope twisted by means of a spindle. The spindle varied in form but was always a shaft, 8 to 12 in. in length, provided at one end with a hook or other means of fastening the thread and at the other end with a circular wharve or whorl of stone or other heavy material to give momentum to the rotating spindle. When 2 or 3 ft. of the rope was prepared as mentioned above, the spindle was twirled with the right hand or laid on the thigh and rotated by passing the hand over the shaft. After the thread was twisted it was wound on the spindle, fastened, and a new portion of rope prepared and twisted. The rope was sometimes fastened to a post and the spindle twisted with both hands, in which case the whorl was not necessary (see Wilkinson, *Anc. Egypt*, I, 317; II, 170, 172). Spinning was the work of both men and women in ancient Egypt. The Bible characterizes it as the work of women (Ex 35; Prov 31 19). The same method of spinning is still used by the women of Syria, although imported yarn is largely taking the place of homespun thread (see DISTAFF).

JAMES A. PATCH

**SPIRIT**, spir'it (רוּחַ, *rūh*; πνεῦμα, *pnēuma*; Lat *spiritus*):

1. Primary and Figurative Senses
  - (1) As Wind, Breath
  - (2) As Anger or Fury
  - (3) As Mental and Moral Qualities in Man
2. Shades of Meaning
  - (1) As Life-Principle
  - (2) As Surviving Death
  - (3) Spiritual Manifestations
3. Human and Divine Spirit
  - (1) The Human as Related with the Divine
  - (2) Operations of the Divine Spirit as Third Person of the Trinity
4. OT Applications
5. Various Interpretations

(1) Used primarily in the OT and NT of the *wind*, as in Gen 8 1; Nu 11 31; Am 4 13 ("creatheth the wind"); He 1 7 (angels,

1. **Primary** "spirits" or "winds" in m); often and **Figura-** used of the *breath*, as in Job 12 10; **tive Senses** 15 30, and in 2 Thess 2 8 (wicked consumed by "the breath of his mouth"). (2) In a figurative sense it was used as indicating *anger* or *fury*, and as such applied even to God, who destroys by the "breath of his nostrils" (Job 4 9; Ex 15 8; 2 S 22 16; see 2 Thess 2 8). (3) Hence applied to man—as being the seat of emotion in desire or trouble, and thus gradually of mental and moral qualities in general (Ex 28 3, "the spirit of wisdom"; Ezk 11 19, "a new spirit," etc). Where man is deeply stirred by the Divine Spirit, as among the prophets, we have a somewhat similar use of the word, in such expressions as: "The Spirit of the Lord came . . . upon him" (1 S 10 10).

(1) The spirit as life-principle in man has various applications: sometimes to denote an *apparition* (Mt 14 26, AV "saying, It is a spirit"; 2. **Shades** Lk 24 37, AV "had seen a spirit"); of **Meaning** sometimes to denote angels, both fallen and unfallen (He 1 14, "ministering spirits"; Mt 10 1, "unclean spirits"; cf also 12 43; Mk 1 23, 26, 27; and in Rev 1 4, "the seven Spirits . . . before his throne"). (2) The spirit is thus in man the principle of life—but of man as distinguished from the brute—so that in death this spirit is yielded to the Lord (Lk 23 46; Acts 7 59; 1 Cor 5 5, "that the spirit may be saved"). Hence God is called the "Father of spirits" (He 12 9).

(3) Thus generally for all the manifestations of the spiritual part in man, as that which thinks, feels, wills; and also to denote certain qualities which characterize the man, e.g. "poor in spirit" (Mt 5 3); "spirit of gentleness" (Gal 6 1); "of bondage" (Rom 8 15); "of jealousy" (Nu 5 14); "of fear" (2 Tim 1 7 AV); "of slumber" (Rom 11 8 AV). Hence we are called upon to "rule over our own spirit" (Prov 16 32; 25 28), and are warned against being overmastered by a wrong spirit (Lk 9 55 AV, "Ye know not what manner of spirit ye are of"). So man may submit to the "spirit of error," and turn away from the "spirit of truth" (1 Jn 4 6). Thus we read of the "spirit of counsel" (Isa 11 2); "of wisdom" (Eph 1 17).

(1) We go a step higher when we find the human spirit brought into relationship with the Divine Spirit. For man is but a creature to whom life has been imparted by God's and Divine spirit—life being but a resultant of Spirit God's breath. Thus life and death are realistically described as an imparting or a withdrawing of God's breath, as in Job 27 3; 33 4; 34 14, "spirit and breath" going together. The spirit may thus be "revived" (Gen 45 27), or "overwhelmed" (Ps 143 4), or "broken" (Prov 15 13). And where sin has been keenly felt, it is "a broken spirit" which is "a sacrifice to God" (Ps 51 17); and when man submits to the power of sin, a new direction is given to his mind: he comes under a "spirit of whoredom" (Hos 4 12); he becomes "proud in spirit" (Eccl 7 8), instead of being "patient in spirit"; he is a fool because he is "hasty in spirit" and gives way to "anger" (Eccl 7 9). The "faithful in spirit" are the men who resist talebearing and backbiting in the world (Prov 11 13). In such instances as these the difference between "soul" and "spirit" appears. See SOUL; PSYCHOLOGY.

(2) On this higher plane, too, we find the Divine Spirit at work. The terminology is very varied here: In the NT we read of the "Holy Spirit," (1 Cor 6 19; Mt 1 18,20; 1 Thess 1 5,6; the "Spirit of God" (1 Cor 2 10 ff.; 3 16; Rom 8 9,11; Eph 3 16, etc.); the "Spirit of Christ" (Rom 8 9; 1 Cor 3 17; Gal 4 6); or simply of "Spirit," with distinct reference to God (1 Cor 2 10; Rom 8 16,23, etc.) God Himself is Spirit (Jn 4 24). Hence God's power is manifested in human life and character (Lk 4 14; Rom 1 1; 1 Cor 2 4; esp. Lk 24 49). The Book of Acts may be termed the Book of the Holy Spirit, working with power in man. This Spirit is placed on a level with Father and Son in the Apostolic Benediction (2 Cor 13 14) and in the parting message of the Saviour to His disciples (Mt 28 19). As the agent in redemption and sanctification His work is glorified by lives "renewed" in the very "spirit of the mind"—a collocation of terms which has puzzled many interpreters (Eph 4 23,24), where *pneuma* and *noûs* appear together, to indicate a renewal which is all-embracing, "renewed in the spirit of your mind, so that the new man is put on, created in righteousness and true holiness" (see also Jn 14 17,26; 15 26; 16 13; 1 Cor 12 11, etc.).

In the OT this spirit of God appears in varied functions, as brooding over chaos (Gen 1 2; Job 26 13); as descending upon men, on heroes like Othniel, Gideon, etc (Jgs 3 10; 6 34), on prophets (Ezek 37 1), on "cunning workmen," like Bezalel and Aholiab (Ex 31 2,3,4, "filled with the Spirit of God"), and specially in such passages as Ps 51 11, where the very presence of God is indicated by an abiding influence of the Holy Spirit: "The Spirit of Jeh is Jeh himself."

May we not reach a still higher stage? Wendt in his interesting monograph (*Die Begriffe Fleisch und Geist*), of which extracts are given in Dickson's

5. Various Interpretations  
*St. Paul's Use of the Terms Flesh and Spirit*, draws attention to the transcendental influence of the Divine *ruach* in the OT as expressed in such phrases as "to put on" (Jgs 6 34), "to fall upon" (14 6,19), "to settle" (Nu 11 25 f). May we not then rightly assume that more is meant than a mere influence emanating from a personal God? Are we not right in maintaining with Davidson that "there are indeed a considerable number of passages in the OT which might very well express the idea that the Spirit is a distinct *hypostasis* or person"? (see SUBSTANCE). Rejecting the well-known

passage in Gen: "Let us make man after our own image," which some have interpreted in a trinitarian sense, we may point to such texts as Zec 4 6, "by my Spirit"; Isa 63 10,11, "They rebelled, and grieved his holy Spirit"; "Where is he that put his holy Spirit in the midst of them?" This is borne out by the NT, with its warnings against "grieving the Holy Spirit," "lying against the Holy Spirit," and kindred expressions (Eph 4 30; Acts 5 3). It is this Spirit which "beareth witness with our spirit, that we are children of God" (Rom 8 16)—the spirit which, as Auberlen has put it (*PREL*, art. "Geist des Menschen"), "appears in a double relationship to us, as the principle of natural life, which is ours by birth, and that of spiritual life, which we receive through the new birth (*Wiedergeburt*)." Hence Paul speaks of God whom he serves "with his spirit" (Rom 1 9); and in 2 Tim 1 3 he speaks of serving God "in a pure conscience." See CONSCIENCE; FLESH; HOLY SPIRIT; PSYCHOLOGY; SOUL.

J. I. MARAIS

SPIRIT, EVIL. See SATAN; DEMON, DEMONIAIC.

SPIRIT, FAMILIAR. See FAMILIAR SPIRIT; DIVINATION; PYTHON.

SPIRIT, HOLY. See HOLY SPIRIT.

SPIRIT OF DIVINATION. See DIVINATION.

SPIRIT, UNCLEAN (OR EVIL). See DEMON, DEMONIAIC.

SPIRITS, DISCERNINGS OF. See DISCERNINGS OF SPIRITS; SPIRITUAL GIFTS.

SPIRITS IN PRISON. See PRISON, SPIRITS IN.

SPIRITUAL, spir'it-ŭ-al (πνευματικός, *pneumatikós*, "spiritual," from πνεῦμα, *pneuma*, "spirit"): Endowed with the attributes of spirit. Any being made in the image of God who is a Spirit (Jn 4 24), and thus having the nature of spirit, is a *spiritual* being.

(1) *Spiritual* hosts of wickedness (Eph 6 12), in distinction from beings clothed in "flesh and blood"—the devil and his angels. This use of the word has reference to nature, essence, and not to character or moral quality. God, angels, man, devil, demons are in essence *spiritual*. The groundwork and faculties of their rational and moral being are the same. This limited use of the word in the NT has its advb. equivalent in Rev 11 8, "which [the great and wicked city] spiritually is called Sodom." As the comprehensive term moral includes immoral, so spiritual includes unspiritual and all that pertains to spirit.

(2) With the above exception, "spiritual" in the NT signifies moral, not physical antithesis: an essence springing from the Spirit of God and imparted to the spirit of man. Hence spiritual in this sense always presupposes the infusion of the Holy Spirit to quicken, and inform. It is opposed (a) to *sarkikós*, *sarkikós*, "fleshly" (1 Cor 3 1), men of the flesh and not of the spirit; (b) to *ψυχικός*, *psuchikós*, "natural" man in whom the *pneuma*, "spirit," is overriden, because of the Fall, by *psuchê*, the principle of the animal life, "soul"; hence the unrenewed man, unspiritual, alienated from the life of God (1 Cor 2 14; 2 Pet 2 12; Jude ver 10). See MAN, NATURAL; (c) to *natural*, meaning physical, "... sown a natural body; ... raised a spiritual body" (1 Cor 15 44).

(3) In the NT and general use "spiritual" thus indicates man regenerated, indwelt, enlightened, endued, empowered, guided by the Holy Spirit; conformed to the will of God, having the mind of Christ, living in and led by the Spirit. The spiritual man is a new creation born from above (Rom 8 6; 1 Cor 2 15; 3 1; 14 37; Col 1 9; 1 Pet 2 5).

(4) Ecclesiastically used of things sacred or



religious, as spiritual authority, spiritual assembly, spiritual office. See SPIRIT. DWIGHT M. PRATT

**SPIRITUAL BLESSING** (εὐλογία πνευματικῆ, *eulogia pneumatikῆ*): Any blessing administered in the realm of the spiritual life; specifically the blessing of the Spirit in introducing the believer into "the heavenly places in Christ" (Eph 1 3); a term expressing the fulness of blessing in God's gift of eternal life in Jesus Christ.

**SPIRITUAL BODY** (σῶμα πνευματικόν, *sōma pneumatikόν*, "body spiritual"): The resurrection-body, a body fitted to the capacities and wants of the spirit in the celestial world; an organism conformed to the spiritual life at the resurrection (see 1 Cor 15 44). See BODY, SPIRITUAL.

**SPIRITUAL DRINK** (πνευματικόν πόμα, *pneumatikόν pōma*): Having a spiritual significance, as referring to the water that flowed miraculously from the smitten rock (1 Cor 10 4; Nu 20 11). Symbolic also of nourishment for the thirsty soul in the sacramental cup and the outpoured blood (life) of Christ. See ROCK, 2, (1); SPIRITUAL ROCK.

### SPIRITUAL GIFTS (χαρίσματα, *charismata*):

1. Gifts Connected with the Ministry of the Word
  - (1) Apostleship
  - (2) Prophecy
  - (3) Discernings of Spirits
  - (4) Teaching
  - (5) The Word of Knowledge
  - (6) The Word of Wisdom
  - (7) Kinds of Tongues
  - (8) Interpretation of Tongues
2. Gifts Connected with the Ministry of Practical Service
  - (1) Workings of Miracles
  - (2) Gifts of Healings
  - (3) Ruling, Governments
  - (4) Helps

#### LITERATURE

The word *charisma*, with a single exception (1 Pet 4 10), occurs in the NT only in the Pauline Epp., and in the pl. form is employed in a technical sense to denote extraordinary gifts of the Spirit bestowed upon Christians to equip them for the service of the church. Various lists of the *charismata* are given (Rom 12 6-8; 1 Cor 12 4-11, 28-30; cf Eph 4 7-12), none of which, it is evident, are exhaustive. Some of the gifts enumerated cannot be said to belong in any peculiar sense to the distinctive category. "Faith" (1 Cor 12 9), for example, is the essential condition of all Christian life; though there were, no doubt, those who were endowed with faith beyond their fellows. "Giving" and "mercy" (Rom 12 8) are among the ordinary graces of the Christian character; though some would possess them more than others. "Ministry" (Rom 12 7), again, i.e. service, was the function to which every Christian was called and the purpose to which every one of the special gifts was to be devoted (Eph 4 12). The term is applied to any spiritual benefit, as the confirmation of Christians in the faith by Paul (Rom 1 11). And as the general function of ministry appears from the first in two great forms as a ministry of word and deed (Acts 6 1-4; 1 Cor 1 17), so the peculiar charismatic gifts which Paul mentions fall into two great classes—those which qualify their possessors for a ministry of the word, and those which prepare them to render services of a practical nature.

(1) *Apostleship* (1 Cor 12 28 f; cf Eph 4 11).—The name "apostle" is used in the NT in a narrower and a wider sense. It was the peculiar title and privilege of the Twelve (Mt 10 2; Lk 6 13; Acts 1 25 f), but was claimed by Paul on special grounds (Rom 1 1; 1 Cor 9 1, etc.); it was probably conceded to James the Lord's brother (1 Cor

15 7; Gal 1 19), and in a freer use of the term is applied to Barnabas (Acts 14 4, 14; cf 1 Cor

9 5, 6), Andronicus and Junias (Rom 16 7). From the *Didache* (xi. 4 ff)

we learn that the ministry of apostles Connected with Ministry of the Word

was continued in the church into the sub-apostolic age (see LITERATURE, SUB-APOSTOLIC). The special gift and function of apostleship, taken in the widest sense, was to proclaim the word of the gospel (Acts 6 2; 1 Cor 1 17, etc), and in particular to proclaim it to the world outside of the church, whether Jewish or gentile (Gal 2 7, 8). See APOSTLE.

(2) *Prophecy* (Rom 12 6; 1 Cor 12 10, 28, 29), under which may be included *exhortation* (Rom 12 8; cf 1 Cor 14 3). The gift of prophecy was bestowed at Pentecost upon the church as a whole (Acts 2 16 ff), but in particular measure upon certain individuals who were distinctively known as prophets. Only a few of the Christian prophets are directly referred to—Judas and Silas (Acts 15 32), the prophets at Antioch (13 1), Agabus and the prophets from Jerus (11 27 f), the four daughters of Philip the evangelist (ver 9). But 1 Cor shows that there were several of them in the Corinthian church; and probably they were to be found in every Christian community. Some of them moved about from church to church (Acts 11 27 f; 21 10); and in the *Didache* we find that even at the celebration of the Eucharist the itinerant prophet still takes precedence of the local ministry of bishops and deacons (*Did.*, x. 7).

It is evident that the functions of the prophet must sometimes have crossed those of the apostle, and so we find Paul himself described as a prophet long after he had been called to the apostleship (Acts 13 1). And yet there was a fundamental distinction. While the apostle, as we have seen, was one "sent forth" to the unbelieving world, the prophet was a minister to the believing church (1 Cor 14 4, 22). Ordinarily his message was one of "edification, and exhortation, and consolation" (1 Cor 14 3). Occasionally he was empowered to make an authoritative announcement of the Divine will in a particular case (Acts 13 1 ff). In rare instances we find him uttering a prediction of a future event (Acts 11 28; 21 10 f).

(3) With prophecy must be associated the *discernings of spirits* (1 Cor 12 10; 14 29; 1 Thess 5 20 f; cf 1 Jn 4 1). The one was a gift for the speaker, the other for those who listened to his words. The prophet claimed to be the medium of Divine revelations (1 Cor 14 30); and by the spiritual discernment of his hearers the truth of his claim was to be judged (ver 29). There were false prophets as well as genuine prophets, spirits of error as well as spirits of truth (1 Jn 4 1-6; cf 2 Thess 2 2; *Did.*, xi). And while prophesying was never to be despised, the utterances of the prophets were to be "proved" (1 Thess 5 20 f), and that in them which came from the Spirit of God spiritually judged (1 Cor 2 14), and so discriminated from anything that might be inspired by evil spirits. See DISCERNINGS OF SPIRITS.

(4) *Teaching* (Rom 12 7; 1 Cor 12 28 f).—As distinguished from the prophet, who had the gift of uttering fresh truths that came to him by way of vision and revelation, the teacher was one who explained and applied established Christian doctrine—the rudiments and first principles of the oracles of God (He 5 12). Possibly (5) *the word of knowledge (gnōsis)* and (6) *the word of wisdom (sophia)* (1 Cor 12 8) are to be distinguished, the first as the utterance of a prophetic and ecstatic intuition, the second as the product of study and reflective thought; and so are to be

related respectively to the functions of the prophet and the teacher. See TEACHER, TEACHING.

(7) *Kinds of tongues (1 Cor 12 10, 28, 30).*—What Paul means by this he explains fully in ch 14. The gift was not a faculty of speaking in unknown foreign languages, for the tongues (*glōssai*) are differentiated from the "voices" or languages (*phōnai*) by which men of one nation are distinguished from those of another (vs 10.11). And when the apostle says that the speaker in an unknown tongue addressed himself to God and not to men (vs 2.14) and was not understood by those who heard him (ver 2), that he edified himself (ver 4) and yet lost the power of conscious thought while praying with the spirit (vs 14 f), it would appear that the "tongues" must have been of the nature of devout ejaculations and broken and disjointed words, uttered almost unconsciously under the stress of high ecstatic feeling.

(8) Parallel to this gift was that of the *interpretation of tongues (1 Cor 12 10.30)*. If the gift of tongues had been a power of speaking unknown foreign languages, the interpretation of tongues would necessarily have meant the faculty of interpreting a language unknown to the interpreter; for to from a familiar language could hardly be described as a *charisma*. But the principle of economy makes it improbable that the edification of the church was accomplished in this round-about way by means of a double miracle—a miracle of foreign speech followed by a miracle of interpretation. If, on the other hand, the gift of tongues was such as has been described, the gift of interpretation would consist in turning what seemed a meaningless utterance into words easy to be understood (ver 9). The interpretation might be given by the speaker in tongues himself (vs 5.13) after his mood of ecstasy was over, as he tr<sup>d</sup> his exalted experiences and broken cries into plain intelligible language. Or, if he lacked the power of self-interpretation, the task might be undertaken by another possessed of this special gift (vs 27.28). The ability of a critic gifted with sympathy and insight to interpret the meaning of a picture or a piece of music, as the genius who produced it might be quite unable to do (e.g. Ruskin and Turner), will help us to understand how the ecstatic half-conscious utterances of one who had the gift of tongues might be put into clear and edifying form by another who had the gift of interpretation. See TONGUES, GIFT OF.

(1) *Workings of miracles (1 Cor 12 10.28.29).*—The word used for miracles in this chapter (*dunámeis*, lit. "powers") is employed in

**2. Gifts** Acts (8 7.13; 19 11.12) so as to cover those cases of exorcism and the cure with **Prac-** tical Service under the separate category of "gifts of healing." As distinguished from the ordinary healing gift, which might be possessed by persons not otherwise remarkable, the "powers" point to a higher faculty more properly to be described as miraculous, and bestowed only upon certain leading men in the church. In 2 Cor 12 12 Paul speaks of the "powers" he wrought in Corinth as among "the signs of an apostle." In He 2 4 the writer mentions the " manifold powers" of the apostolic circle as part of the Divine confirmation of their testimony. In Rom 15 18 ff Paul refers to his miraculous gifts as an instrument which Christ used for the furtherance of the gospel and the bringing of the Gentiles to obedience. The working of "powers," accordingly, was a gift which linked itself to the ministry of the word in respect of its bearing upon the truth of the gospel and the mission of the apostle to declare it. And yet, like the wider and lower gift of healing, it must be regarded primarily as a gift of practical beneficence,

and only secondarily as a means of confirming the truth and authenticating its messenger by way of a sign. The Book of Acts gives several examples of "powers" that are different from ordinary healings. The raising of Dorcas (9 36 ff) and of Eutychus (20 9 ff) clearly belong to this higher class, and also, perhaps, such remarkable cures as those of the life-long cripple at the Temple gate (3 1 ff) and Aeneas of Lydda (9 32 ff).

(2) *Gifts of healings (1 Cor 12 9.28.30).*—See HEALING, GIFTS OF.

(3) *Ruling (Rom 12 8), governments (1 Cor 12 28).*—These were gifts of wise counsel and direction in the practical affairs of the church, such as by and by came to be formally intrusted to presbyters or bishops. When Paul wrote to the Corinthians, the ministry of office had not yet supplanted the ministry of inspiration, and Christian communities were guided and governed by those of their members whose wisdom in counsel proved that God through His Spirit had bestowed upon them the gift of ruling.

(4) *Helps (1 Cor 12 28).*—This has sometimes been understood to denote the lowliest Christian function of all in Paul's list, the function of those who have no pronounced gifts of their own and can only employ themselves in services of a subordinate kind. But the usage of the Gr word (*antilēmpsis*) in the papyri as well as the LXX points to succor rendered to the weak by the strong; and this is confirmed for the NT when the same Gr word in its verbal form (*antilambánō*) is used in Acts 20 35, when Paul exhorts the elders of the Ephesian church to follow his example in helping the weak. Thus, as the gift of government foreshadowed the official powers of the presbyter or bishop, the gift of helps appears to furnish the germ of the gracious office of the deacon—the "minister" *par excellence*, as the name *diákonos* denotes—which we find in existence at a later date in Philippi and Ephesus (Phil 1 1; 1 Tim 3 1–13), and which was probably created, on the analogy of the *diakonia* of the Seven in Jerus (Acts 6 1 ff), as a ministry, in the first place, to the poor. See, further, HELPS.

LITERATURE.—Hort, *Christian Ecclesia*, Lect X; Neander, *Hist of the Planting of the Christian Church*, I, 131 ff; Weizsäcker, *Apostolic Age*, II, 255–75; Lindsay, *Church and Ministry*, *passim*; EB, IV, art. "Spiritual Gifts"; ERE, III, art. "Charismata"; PRE, VI, art. "Geistgaben."

J. C. LAMBERT

**SPIRITUAL HOUSE** (*οἶκος πνευματικός, oikos pneumatikós*, "house spiritual"): A body of Christians (a church), as pervaded by the Spirit and power of God (1 Pet 2 5); a term applicable to God's house: "house of prayer," the temple (Mt 21 13); to heaven: "my Father's house" (Jn 14 2); to the tabernacle: "Moses . . . faithful in all his house" (He 3 2); to saints: as "the household of God" (Eph 2 19), and "the temple of the Holy Spirit" (1 Cor 6 19); hence any "habitation of God in the spirit" (Eph 2 22) in which His glory dwells and His power and grace are manifest.

**SPIRITUAL MAN** (*ὁ πνευματικός, ho pneumatikós*): In distinction from the natural, the unrenewed man (1 Cor 2 15); man in whom the Holy Spirit dwells and rules. This Divine indwelling insures mental illumination: "He that is spiritual discerneth [AVm] [or interpreteth] all things"; moral renewal: "a new creature" (2 Cor 5 17); "a new man" (Eph 4 24); spiritual endowment: "Ye shall receive power" (Acts 1 8). See SPIRITUAL, 2; SPIRITUALITY; MAN, NEW.

**SPIRITUAL MEAT** (*βρῶμα πνευματικόν, brōma pneumatikón*, "food spiritual"): Nourishment for the soul, referring specifically (1 Cor 10 3) to the

manna by which the children of Israel were miraculously fed and which was made by Paul prophetically equivalent to the broken bread of the Christian sacrament symbolizing the body of Christ. Hence (1) Christ Himself as the food of the soul: "I am the bread of life" (Jn 6 48-58); (2) anything that nourishes the spiritual life: (a) obedience to the will of God: "My meat is to do the will of him that sent me" (Jn 4 32-34); (b) the truths of God in the Scriptures: "Word of righteousness" = "strong meat" (He 5 12-14); "word of God" (Mt 4 4); (c) the things of the Spirit (1 Cor 3 1-2; cf ch 2).

DWIGHT M. PRATT

**SPIRITUAL ROCK** (πνευματικὴ πέτρα, *pneumatikḗ pétra*): Having a spiritual significance: supernatural, manifesting the power of the Divine Spirit; allegorically applied to Christ as fulfilling the type in the smitten rock in the desert, from which water miraculously burst forth to nourish the Israelites. A tradition current among the Jews affirms that this rock followed the people in their journeyings and gave forth a living stream for their supply. Paul made this ever-flowing rock a beautiful and accurate symbol of Christ: "The rock was Christ" (1 Cor 10 4).

Without the characterizing word "spiritual," this figurative term, with the same significance, is common to the Scriptures, applied (1) to Jeh, God: "Rock of his salvation," (their rock is not as our Rock" (Dt 32 15-31); "Jeh is my rock" (Ps 18 2; cf Isa 26 4: 32 2: 1 S 2 2; 2 S 22 2); (2) to the foundation-stone of Christian confession and testimony (Mt 16 18; cf Eph 2 20; 1 Cor 3 11; 1 Pet 2 6-8), and thus to Christ Himself; (3) in Christian hymnology to Jesus crucified and spear-pierced: "Rock of ages, cleft for me."

DWIGHT M. PRATT

**SPIRITUAL SACRIFICE** (πνευματικὰ θυσίαι, *pneumatiká thusíai*): A figure taken from the victim slain and offered on the altar, as e.g. the paschal lamb; thus signifying the complete and acceptable offering of the self-dedicated spirit. As the temple, priesthood and God Himself are spiritual, so is the sacrifice of the consecrated believer (1 Pet 2 5); cf "living sacrifice" (Rom 12 1); "sacrifice of praise" (He 13 15,16). Any self-dedicating act of the inner man; the devout, renewed, consecrated spirit, e.g. Christian benevolence (Phil 4 18); "to do good and to communicate" (He 13 16); "mercy" and "knowledge of God," instead of material and outward sacrifice (Hos 6 6). This is defined and beautifully illustrated in the classic verse on this theme, "The sacrifices of God are a broken spirit," etc (Ps 51 17).

DWIGHT M. PRATT

**SPIRITUAL SONGS** (ὕμνοι πνευματικοί, *hymnoi pneumatikoi*): ὕμνος, ὁδῆ, Eng. "ode," is the general, and generic word for "song," of which "psalms and hymns" are specific varieties (Eph 5 19; Col 3 16). It includes all lyric poetry, but is limited by the word "spiritual" to songs inspired by the Holy Spirit and employed in the joyful and devotional expression of the spiritual life. While songs, like psalms and hymns, were used in public worship and praise, they were more intended for, and suited to, personal and private and social use; as, e.g. in family worship, at meals, in the *agapai* ("love-feasts"), in meetings for prayer and religious intercourse from house to house. The passages above cited give apostolic authority for the use of other than the OT psms in public praise, and rebuke the narrowness and unbelief that would forever limit the operations of the Holy Spirit and the hymnology of the church to the narrow compass of the Davidic era and the Davidic school of poetry and song.

The "new song" of Rev 5 9; 14 3, and "the song of Moses and of the Lamb" (15 3), indicate that spiritual songs are to be perpetuated in the eternal melodies of the redeemed. DWIGHT M. PRATT

**SPIRITUAL THINGS** (τὰ πνευματικά, *tá pneumatiká*): Things proceeding from the Holy Spirit and pertaining to man's spiritual life, worship, service. Contrasted in 1 Cor 9 11 and in Rom 15 27 with τὰ σαρκικά, *tá sarviká*, things fleshly, physical, which have to do with man's sensuous, corporeal nature, such as food, raiment, money. By "spiritual things" Paul signifies the benefits accompanying salvation, the gifts of the Spirit—faith, hope, love, justification, sanctification, peace—all the fruits and blessings and aids of the regenerate life.

**Ecclesiastically:** Things pertaining to spiritual office, the ministry of the Word, or the service of the sanctuary. DWIGHT M. PRATT

**SPIRITUALITY**, spir-it-ŭ-al'i-ti: The state of being spiritual in the higher use of the word. It is purely a religious term and signifies the state of a soul vitalized by the Divine Spirit and made alive unto God. It covers the entire range of man's faculties: intellect, feeling, will—all the attributes of personality.

The intellectual can be divorced from the spiritual, but the spiritual can never be divorced from the intellectual. If a man is spiritual,

1. **Intellect** his intellect is touched with the Divine life and comes under the power of the Divine baptism. One word describes this mental quickening and illumination—"vision." "The pure in heart shall see God." Paul affirms (1 Cor 2 12,13) that the Spirit of God operates directly on the mental faculties, adjusting reason and intellect to the Divine reason, and enabling man to think God's thoughts and discern His purposes, nature and will. The common use of the word "spirituality" limits it mistakenly to religious experience, narrowly interpreted, but as spirituality brings the intellect into harmony with the Divine reason in every realm of mental action, it may be as manifest in science, art, philosophy, commerce and law as in religion.

The feelings and emotions are fertile soil for the spiritual life. Love is the beginning and end of true religion. Spirituality in the realm of the affections is that state of soul in which the heart with its holiest love is centered on God as revealed in Christ. The specific and supreme work of the Holy Spirit is to shed abroad God's love in the heart (Rom 5 5). Spirituality sets the affections on things above and brings the entire emotional nature under the regulating and redeeming sway of the Holy Spirit.

A spiritually-minded man is one whose will is set on God as well as his intellect and affections.

2. **Affections** in every fiber of his moral being, and in all the activities of his soul, he is under the guidance and dominion of the Holy Spirit. The affections present motives, the intellect estimates their worthiness, the will decides upon the course of action. When this trinity of mental operation—necessary to normal manhood—is under the sway of the Divine Spirit, man possesses spirituality, a state in which all the faculties of the soul are voluntarily and joyfully under the dominion and guidance of Christ's indwelling Spirit. When intellect, heart and will focus their energies reverently and affectionately upon Him, love—a passionate, ever-present, everdominant love—is the result. This is the triune sphere of the Holy Spirit's indwelling and activity, and the character of such a God-centered and Spirit-filled life is described by the exalted word "spirituality."

DWIGHT M. PRATT

**SPIRITUALLY**, spir-it-ŭ-al-i (πνευματικῶς, *pneumatikōs*): As in 1 Cor 2 14, "spiritually judged,"

i.e. by means of the spirit renewed and enlightened by the Spirit of God; having the mind of the Spirit is to be spiritually-minded (cf AV and RV Rom 8 6).

Allegorically used also (Rev 11 8) to characterize, in a bad sense, the qualities of the spiritual (i.e. the spirit's) life: "which spiritually is called Sodom." See SPIRITUAL.

**SPIT**, spit, **SPITTLE**, spit'1 (רַקַּק, *yāraḳ*, רָק, *rōk*; [ἐμ]πτύω, [*em*]ptūō): Spitting in a person's face indicated gross contempt (Nu 12 14; Dt 25 9; Job 30 10; Isa 50 6; Mt 26 67; 27 30, etc); when performed by an unclean person it produced defilement (Lev 15 8) which necessitated washing the clothes and a bath. When David allowed his spittle (רִיר, *rīr*) to run down over his beard, it was his purpose to behave like a lunatic (1 S 21 13). "Till I swallow down my spittle" (Job 7 19) has the same import as the Eng. "in the twinkling of an eye" (1 Cor 15 52). Spittle was used by Our Lord in restoring sight and speech (Mk 7 33; Jn 9 6) as signifying His will to cure. It was a widespread belief that spittle, accompanied with magical formulae, possessed medicinal qualities. "Oil" possessed a similar virtue (Mk 6 13; Jas 5 14).  
T. LEWIS

**SPOIL**, spoil. See BOOTY; WAR, 8.

**SPOILER**, spoil'er (חַשְׁבֵּר, *ha-shōdhēdh*, "the spoiler"): A favorite expression of the prophet Jeremiah by which he describes generally the enemies that invade and devastate a country—with special reference to enemies that invade Judah (Jer 12 12; 15 8); to enemies who devastate Moab (48 8,18); to enemies from the N. who are to assail Babylon (51 48), and in one case (6 26) to Nebuchadrezzar making an irresistible advance upon Jerus. ARV uniformly renders "destroyer."

**SPOKE**, spōk (1 K 7 33). See SEA, MOLTEN.

**SPONGE**, spunj (σπόγγος, *spōggos*): The word "sponge," AV "spunge," occurs only in the accounts of Our Lord's crucifixion in Mt 27 48; Mk 15 36; Jn 19 29. Sponges have been known from the earliest periods. They are mentioned by Homer, Aeschylus, Aristophanes and other ancient writers. The sponge fisheries of the Eastern Mediterranean are still among the most important in the world. Sponges are animals of a very simple organization, fixed to rocks or other objects in the sea or in fresh water. The marketable sponge consists of a mass of soft interlacing fibers which constituted the skeleton of the living animal. The sponge fishers of the Levant dive from boats, with or without diving apparatus, and tear the sponges from the rocks with their hands. The sponges are allowed to die and rot in the air and are then thoroughly washed until nothing but the skeleton remains. Sponges which have calcareous or silicious skeletons are unfit for use.  
ALFRED ELY DAY

**SPOON**, spōon (כַּף, *kaph*; LXX θυτήρα, *thutēskē*, except in Jer 52 18, where it is κρέατρα, *krēātra*, lit. "fork"): A hollow vessel, a censer; a small vessel in which incense was to be burnt, as is seen from the account given in Nu 7 of the oblations of the princes of the tribes after the setting-up of the tabernacle. Beginning with ver 14 of this chapter, we meet at every succeeding 6th verse the statement, "one golden spoon of ten shekels, full of incense," till at ver 86 the summary statement is made, "the twelve golden spoons, full of incense."

**SPORTS**, spōrts. See GAMES.

**SPOT**, spot, **SPOTTED**, spot'ed (מַמְ, *mūm*; σπῆλος, *spīlos*): The Heb word is used to denote a blemish which mars the perfection of the face, as in Cant 4 7; Job 11 15. It is tr'd "blemish" in Lev 24 19 f, where it means an injury the result of violence, and is rendered "blot" in Prov 9 7, where it signifies "shame" or "disgrace." The "spotted" cattle of Gen 30 32-39 are animals of variegated color (טָלָא, *tālā*; cf Ezk 16 16, "decked with divers colors"; Josh 9 5, "patched"). For ḥābharburāh in Jer 13 23, see LEOPARD. *Spilos* is used in the figurative sense of a stain of sin in 2 Pet 3 14, and similarly along with *rhutis* ("a wrinkle") in Eph 5 27. The "garment spotted [vb. *spilōmai*] by the flesh" of Jude ver 23 is, as Calvin has paraphrased it, anything that in any way savors of sin or temptation. The "spots" of Jude ver 12 AV are *spīlades*, "hidden [sunken] rocks" which are betrayed by the surf beating over them (as in Homer *Od.* iii.298), and are so rendered in RV. "Spot" in Lev 13 is referred to under FRECKLED SPOT; LEPROSY; TETTER.

"Without spot" in Nu 19 2, etc, is *tāmīm*, a usual word for "perfect" (so RVm); *aspīlos* (the negative form of *spīlos*) occurs in 1 Tim 6 14; 1 Pet 1 19; 2 Pet 3 14, with Jas 1 27 ("unspotted"). For AV He 9 14 see BLEMISH. ALEX. MACALISTER

**SPOUSE**, spouz (קַלְהָ, *kallāh*, "bride," "daughter-in-law"): RV gives "bride" for AV "spouse" in Cant 4 8 ff, and "brides" for "spouses" in Hos 4 13 f (m "daughters-in-law"). See ESPOUSAL; MARRIAGE; RELATIONSHIPS, FAMILY.

**SPREAD**, spred, **SPREADING**, spred'ing: Alone, or in phrases like "spread abroad," "spread forth," etc, "spread" represents very many Heb terms, principally פָּרַשׁ, *pāras*; in the NT the act of spreading is *στρόννυμι*, *strōnnumi*, where in Mt 21 8b AV has "strawed" (g.v.); compound in Lk 19 36. For "spread abroad" in Mk 1 28; 1 Thess 1 8 (*exērchomai*), RV has "went out" and "gone forth"; conversely, RV has "spread abroad" for AV "break forth" (Isa 54 3) and "published" (*diaphērō*, Acts 13 49), and for "commonly reported" (*diaphēmīzō*, Mt 28 15).

**SPRING**. See FOUNTAIN; WELL.

**SPRINKLE**, sprin'k'l, **SPRINKLING**, sprin'kling (רָקַק, *zarak*, נָזַח, *nāzāh*; ραντίζειν, *ranitizein*): The first word means "to toss" or "scatter abundantly," e.g. in handfuls, as dust on the head (Job 2 12) or blood from a bowl (Ex 9 8). The other Heb word is used of sprinkling with the finger (Lev 14 7; 16 14, etc). In the account of Jezebel's death the word is used in its literal meaning of "spurt" (2 K 9 33).

Sprinkling (blood, water, oil) formed an important—if not the essential—part of the act of sacrifice. A consideration of the chief passages in the OT will reveal the prominence and the significance of sprinkling as a feature of the sacrificial act. The significance of the sprinkling of blood is seen in the account of the establishment of the covenant between Jeh and Israel (Ex 24 6-8). Half the blood was sprinkled on the altar as representing the Deity, while the remainder was put into a basin and then sprinkled on the people. This ceremony is a survival in a modified form of the communal meal in which the tribal god and his worshippers sat together and participated in the same food, and in this way came to possess the same life. The two-fold sprinkling of blood resulted in the establishment

of an inviolable bond (Nu 18 17; 2 K 16 15). In the account of the consecration of Aaron and his sons (Ex 29 16.20.21) the blood of the ram of the burnt offering was sprinkled on the altar, while the blood of the ram of consecration was put on the altar and sprinkled on Aaron and his sons and on their garments. Water of purifying was sprinkled on the Levites at their ordination (Nu 8 7). Lev gives detailed information in regard to sacrificial sprinkling. In the case of burnt offering the blood was sprinkled round about upon the altar (Lev 1 5.11). The same practice obtained in the case of peace offerings, whether ox, lamb or goat (Lev 3 2.8.13). When a sin offering for sins inadvertently committed was made, the priest dipped his fingers in the blood and sprinkled it seven times before Jeh, before the veil of the Holy Place (Lev 4 6). Elsewhere (Lev 16 11.15) we read that Aaron took the blood of the sin offering and sprinkled it with his finger upon the mercy-seat, eastward, 7 t (see also Nu 19 4). Sprinkling constituted part of the process of purification. But it is obvious that the sprinkling, even in this case, was a religious act, and not part of the actual physical cleaning. A simple kind of sprinkler was made by fastening a bunch of hyssop to a cedar rod by a piece of scarlet thread or wool and then the patient was besprinkled 7 t (Lev 14 7), while oil was sprinkled with the finger, also 7 t, before Jeh (Lev 14 16; see also Ex 12 22; Nu 19 18; Ps 51 7). The house in which the leper lived was disinfected in the same thorough manner (Lev 16 51).

In the case of persons who had contracted uncleanness through contact with a corpse, sprinkling with the "water of separation" was part of the process of cleansing. The water of separation consisted of the ashes of a red heifer (slain for the purpose) mixed with running water (Nu 19). A sprinkler was used as in the case of the leper (19 18). The final sprinkling—on the 7th day—was followed by a bath (ver 19). The "tent" in which the corpse lay, together with all the contents, were thoroughly disinfected (see *HEIFER*, *KED*).

According to Ex (9 8.10) the plague of "boils and blains" was caused through the sprinkling of ashes ("soot" RVm) in the air toward heaven, which settled on man and beast and produced the eruption. The narrative gives no clue in reference to the connection between the ashes and the eruption, but the religious character of the act is obvious. By means of it, the assistance of the Deity was invoked. According to primitive thought, there was no necessary connection between the religious act and the consummation devoutly wished for. The purpose of the religious observance was to influence, or bring pressure to bear upon, the Deity so that He might exert Himself on behalf of the worshipper. It is evident that sprinkling as part of the act of worship was believed to be religiously effectual. It was not symbolical nor morally significant. It was a religious act. It is not denied that in some passages sprinkling is symbolical. According to Ezk (36 25) the restored community will experience moral and spiritual renewal. There will be a "new heart" and a "new spirit." The sprinkling with clean water is the outward symbol of the inward lustration. In Isa 63 3 the sacrificial allusion is obvious. The conqueror who strides triumphantly from Bozrah is "besprinkled" with the life-blood (or juice) of his victims. In Isa 52 15 "sprinkle" is a doubtful rendering. There is no apparent connection between bodily disfigurement and national purification. RVm renders "startle" (lit. "cause to spring"). The exalted dignity of the "martyr" will excite the wonder of kings and peoples.

In 1 Pet 1 2, "sprinkling of the blood of Jesus Christ" is used figuratively of its cleansing efficacy (cf He 9 13.14; 10 22). T. LEWIS

**SPURIOUS**, spū'ri-us, ACTS, EPISTLES, GOSPELS. See APOCRYPHAL ACTS; APOCRYPHAL EPISTLES; APOCRYPHAL GOSPELS.

**SPY**, spī. See *ESPY*.

**STACHYS**, stāk'is (Στάχυς, *Stáchus*): The name of a Rom Christian to whom Paul sent greetings. The name is Gr and uncommon; it has been found in inscriptions connected with the imperial household. Paul designates him "my beloved" (Rom 16 9).

**STACK**, stak: Ex 22 6 AV, RV "shocks" (of grain).

**STACTE**, stak'tē (שֹׁטָף, *nāṭāph*, "drops" [Job 36 27]; στακρή, *staklē*, meaning "oozing out in drops"): One of the ingredients of the holy ointment (Ex 30 34; Eccles 24 15, m "opobalsamum," AV "storax"). The marginal reading is a concession to Jewish tradition, but see *SPICE*, (1). Dioscorides describes two kinds of stacte, one of pure myrrh and one of storax and a fat mixed. See *MYRRH*. This *nāṭāph* must have been either myrrh "in drops," as it is collected, or some other fragrant gum, similarly collected, such, for example, as gum tragacanth.

**STAFF**, staf: Many Heb terms are represented by this word. The "staves" of the ark translate the word שֵׁט, *badh*, lit. "a part," hence branch, bar, etc (Ex 25 13.14.15.27.28, etc). Other words, as *matteh*, *makkel*, *shebhet*, used of the staff in the hand, the shepherd's staff, figuratively, "staff of bread" (*matteh*, Ezk 4 16; 5 16; 14 13), as indispensable for support of life, are dealt with under *ROD* (q.v.). The NT word is *πάβδος*, *rhábdos* (Mt 10 10 || Lk 9 3; He 11 21). See also *SCEPTRE*.

**STAIR**, stár. See *HOUSE*.

**STAKE**, sták: Isa 33 20; 54 2 for שֵׁט, *yāthēdh*, "tent-pin," or, perhaps, "tent-pole" (Ex 27 19; Jgs 4 21, etc). AV Sir 43 19, "The hoar frost, . . . being congealed, lieth on the top of sharp stakes," is of course meaningless. RV "When it is congealed, it is as points of thorns" renders the Gr very exactly, but the Heb would indicate for the original meaning "forms frost-flowers of sapphire."

**STALK**, stók: In Gen 41 5.22 is for קָנֶה, *kāneh*, "cane"; in Josh 2 6 for עֵץ, 'ēg, "wood." In Hos 8 7, RVm has "stalk" for קָמָה, *kāmāh*, "that which stands." RV's "standing grain" is due to this meaning of *kāmāh* in Ex 22 6, etc, but this tr spoils the figure. The meaning is, "They sow the wind, a worthless sowing, for such seed produces no stalk, it yields no grain."

**STALL**, stól ([1] מַרְבֵּק, *marbēk*, lit., "a place for tying up" [Am 6 4; Mal 4 2], [2] אֲבָשָׁה, 'ābhaš, "to give fodder" [Prov 15 17], [3] אֲרָוָה, 'urwāh, "to pluck and feed" [1 K 4 26; 2 K 9 25; 32 28], [4] רֵפֶת, *repheth*, "a resting place" [Hab 3 17]; [5] פֶּאֲרַת, *phātme*, "a manger" or "crib" [Lk 13 15; cf אֲבָשָׁה, 'ēbhūš, tr<sup>d</sup> "crib" in Isa 1 3; Prov 14 4]): During the season when cattle are not being used they are allowed to roam in the fields. Otherwise they are tied in rooms in the winter time, or under shelters made of green boughs in the summer, and all their food brought to them. Horses and cattle alike are haltered and the chains fastened through holes made in stones projecting from the walls. No stanchions and no separating partitions between

animals are used. The horses are usually hobbled as well.

JAMES A. PATCH

**STAMMERER**, *stam'ēr-ēr*: Isa 32 4, שִׁטְט, *šillēgh*, "inarticulate speaking." In Isa 28 11; 33 19, *l'g* (pointing uncertain) is rendered "strange" by RV, with "stammering" in AV, RVm. Probably the word means both, as primitive people always think that their own language alone is clearly pronounced. Or the word may mean "mocking."

**STANDARD-BEARER**, *stand'ard-bār'ēr*. See WAR, 5; BANNER.

**STANDARDS**, *stand'ardz*. See WAR, 5; BANNER; ASTRONOMY, II, 7.

**STANDING**, *stand'ing*. See ATTITUDES.

**STAR**, *stār*, **STARS**, *stārz*. See ASTRONOMY, I, 6.

**STARGAZERS**, *stār'gāz-ērz*. See ASTROLOGY, 5.

**STAR IN THE EAST**. See STAR OF THE MAGI; MAGI.

**STAR OF BETHLEHEM**. See STAR OF THE MAGI.

**STAR OF THE MAGI:**

1. The Magi
2. Herod's Enquiry
3. Two Facts concerning the Star
4. The Wisdom of the Magi Not Astrological
5. The Prophecy of Balaam
6. The Star Not a Conjunction of Planets
7. The Star Not *Nova Cassiopeiae*
8. The Legend of the Well
9. Lesson of the Narrative

The birth of Our Lord was announced in a supernatural manner not only to Jews by the angelic message to the shepherds, but also to

**1. The Gentiles**, for "Wise-men from the east came to Jerusalem, saying, Where is he that is born King of the Jews? for we saw his star in the east, and are come to worship him" (Mt 2 1.2). The word which has been rendered "wise men" in AV and ERV (ARV "Wise-men") is "Magi." These, according to Herodotus, were originally a tribe of the Medes (Herodotus i.101) and from their supposed skill in divination the term was applied to the learned and priestly caste among the followers of Zoroaster; they were thus in principle worshippers of one only God, and rejecters of polytheism and idolatry. The simple creed and high morality, which Zoroastrianism in its purest form professed, were well adapted to prepare its faithful disciples to receive a further revelation, and we may reasonably believe that the wise men who had been thus guided to worship the new-born king of the Jews had been faithful to the light afforded to them, for "in every nation he that feareth him [God], and worketh righteousness, is acceptable to him" (Acts 10 35). See MAGI.

The gospel tells us that the arrival of the Magi at Jerus threw Herod the king and all the city into great excitement, and Herod at once

**2. Herod's Enquiry** called a council of all the chief priests and scribes of the people that he might learn from them where the Messiah should be born. In reply they quoted to him the prophecy of Micah which had indicated Bethlehem as the destined site. "Then Herod privily called the Wise-men, and learned of them exactly what time the star appeared. And he sent them to Bethlehem,

and said, Go and search out exactly concerning the young child; and when ye have found him, bring me word, that I also may come and worship him. And they, having heard the king, went their way; and lo, the star, which they saw in the east, went before them, till it came and stood over where the young child was. And when they saw the star, they rejoiced with exceeding great joy" (Mt 2 7-10). So much, and no more, are we told of the star of the Magi, and the story is as significant in its omissions as in that which it tells us.

What sort of a star it was that led the wise men; how they learned from it that the King of the Jews

**3. Two Facts concerning the Star** was born; how it went before them; how it stood over where the young Child was, we do not know. We are indeed told but two facts concerning it: first, that its appearance in some way or other did inform the wise men,

not of the birth of a king of the Jews, but of the King of the Jews for whose coming, not Israel only, but more or less consciously the whole civilized world was waiting; next, that, when they had come to Judaea in consequence of this information, the star pointed out to them the actual spot where the new-born King was to be found. It went before them till it came and stood over where the young Child was. It may also be inferred from Mt 2 10 that in some way or other the wise men had for a time lost sight of the star, so that the two facts mentioned refer to two separate appearances. The first appearance induced the Magi to leave the East and set out for Judaea; the second pointed out to them the place at Bethlehem where the object of their search was to be found. Nothing is told us respecting the star except its work as a guide.

There can be no doubt that the Magi took their journey in obedience to direct revelation from God, and since we are told that God warned them in a dream not to return to Herod, so that they departed to their own country another way, it is but reasonable to suppose that their outward journey had been directed in a similar manner.

It has been conjectured that as the Magians were credited with a great skill in astrology they may have been able to forecast the birth of Our Lord by the rules of their art. But this conjecture must be peremptorily rejected. It ascribes to the pseudo-science of astrology a reality to which it has no claim, for it is inconceivable that the planetary configurations can really foretell the birth of princes.

**4. The Wisdom of the Magi Not Astrological** Even if it were admitted that such could be the case, no such event could be taken as indicating the One Birth for which the world was waiting, unless some direct and explicit revelation from God had been received to that effect. For that Birth was necessarily unique, and science can deal only with repeated events. No astronomical research is now, or was at any time, competent in itself to supply the indication needed; it was not in virtue of any natural learning that the wise men understood the meaning of the star. And if a mere astronomical research was helpless to supply any such power of prediction, still more emphatically must the claim of "occult knowledge" be disallowed. So far as occult knowledge has had any basis in fact at all, it has been simply a euhemistic way of describing the frauds, impostures and crimes by which debased heathen priesthoods and "medicine men" have imposed upon the gross superstition of their followers. The very suggestion that, by means like these, God's purpose would be made known shows that those who suggest it have not entirely shaken off the influence of heathenism.

The suggestion has often been made that the prophecy of Balaam, "There shall come forth a star out of Jacob, and a sceptre shall rise out of Israel" (Nu 24 17), may have been preserved in the East and have furnished the clue upon which the Magi acted. It is a pleasing thought that these devout Gentiles had thus preserved and meditated upon the prophecy given through one who may well have been of an allied

**5. The Prophecy of Balaam** star out of Jacob, and a sceptre shall rise out of Israel" (Nu 24 17), may have been preserved in the East and have furnished the clue upon which the Magi acted. It is a pleasing thought that these devout Gentiles had thus preserved and meditated upon the prophecy given through one who may well have been of an allied

**5. The Prophecy of Balaam** star out of Jacob, and a sceptre shall rise out of Israel" (Nu 24 17), may have been preserved in the East and have furnished the clue upon which the Magi acted. It is a pleasing thought that these devout Gentiles had thus preserved and meditated upon the prophecy given through one who may well have been of an allied

order to themselves; but that prophecy can surely not have been sufficient in itself, and some much more direct intimation must have been vouchsafed to them; though the prophecy may have aided their faith and have dictated the form in which they announced their mission to King Herod and the Jews.

We are not told how the Magi learned the meaning of the star, neither are we told what kind of a star it was.

### 6. The Star Not a Conjunction of Planets

Some three centuries ago the ingenious and devout Kepler supposed that he could identify the star with a conjunction of the planets Jupiter and Saturn in the constellation *Pisces*, the two planets being so close as to seem a single star. This conjunction took place in the month of May, 7 BC, not very long before the birth of Our Lord is supposed to have taken place. But the late Professor Pritchard has shown (*Nature and Revelation*, 243-55), first, that a similar and closer conjunction occurred 59 years earlier, and should therefore have brought a Magian deputation to Judaea then. Next, that the two planets never approached each other nearer than twice the diameter of the moon, so that they would have appeared, not as one star, but as two, and thirdly, if the planets had seemed to stand over Bethlehem as the wise men left Jerus, they would assuredly not have appeared to do so when they arrived at the little city. Ingenious as the suggestion was, it may be dismissed as unworthy of serious consideration.

Another suggestion has received at times a very wide popularity. In the year 1572 a wonderful new star appeared in the constellation *Cassiopeia*.

### 7. Not *Nova Cassiopeiae*

At its brightest it outshone Venus and was visible in the daylight, and though it gradually declined in splendor it was not lost to sight until after 16 months. There have been other instances of outbursts of short-lived bright stars, and in the annals of the years 1265 and 952 some brief notices have been found which may have referred to objects of this class, but more probably described comets. The guess was then hazarded that these three events might all refer to the same object; that the star in *Cassiopeia* might be a "variable" star, bursting into brilliancy about every 350 years or so; that it was the star that announced the birth of Our Lord, and that it would reappear about the end of the 19th cent. to announce His second coming. This rumor was widely spread, and from time to time ignorant people have noticed the planet Venus which shines with extraordinary brilliancy when in particular parts of her orbit, and have imagined, esp. when she has been thus seen as a morning star in the east, that she was none other than the star of Bethlehem at its predicted return. There is no reason to suppose that the star of 1572 had ever appeared before that date or will ever appear again; but in any case we are perfectly sure that it could not have been the star of Bethlehem, for *Cassiopeia* is a northern constellation, and the wise men in their journey from Jerus to Bethlehem had *Cassiopeia* and all her stars behind their back.

The statement that the star "went before" the Magi gives the impression that it was some supernatural light like the *sh'khinah*, "glory," resting upon the tabernacle, or the pillar of fire which led the children of Israel through the wilderness. But this view raises the questions as to the form in which it first appeared to the wise men, when they were still in the East, and how they came to call it a star, when they must have recognized how un-starlike it was. On the other hand, if what they saw when in the East was really a star, it seems most difficult to understand how it can have appeared to go before them and to stand over the place where the young Child lay.

Yet there is a legend still current in Pal which may possibly explain how an actual star may have fulfilled this part, and there is a well at Bethlehem that is still shown to

### 8. The Legend of the Well

pilgrims as the means whereby the wise men "saw the star" the second time. It is said that when they had reached Bethlehem, apparently nearly at mid-day, one of them went to the well of the inn in order to draw water. Looking down into the well he saw the star reflected from the surface of the water and knew that it must be directly overhead. Its re-observation under such unusual circumstances would be a sufficient assurance to the Magi that they had

reached the right place, and inquiry in the inn would soon inform them of the visit of the shepherds, and of the angelic message which had told them where to find the babe "born in the city of David, the Saviour, which is Christ the Lord."

If we may accept this legend we may take the star as having been what astronomers know as a "new" or "temporary" star, like that of 1572. When the Magi first saw it, and in consequence set out upon their journey, it may have been an evening star and thus, being seen only in the west shortly after sunset, it would appear, evening after evening, to point them their way to Judaea. As they journeyed thither it probably faded as temporary stars in general quickly do. At the same time it would have drawn nearer and nearer to the sun, until it was lost in its rays by the time they reached Jerus, when they would seem to have lost sight of it altogether. Having thus lost it, they would naturally not expect to see it again until it had drawn away from the sun on the other side, and been detected as a morning star in the east before sunrise; they would not expect to discover it in the daytime.

In the ordinary way, the planet Venus is, after the two "great lights," the brightest object in the heavens, but temporary stars are on record that have even exceeded Venus in brightness. The difficulty of seeing the planet Venus in full sunshine does not lie in her want of brightness, but in picking up and holding steadily so minute a point of light in the broad expanse of the gleaming sky. This difficulty, which would be even greater in the case of a star, would be lessened by looking down the well, as the shaft would narrow the field of view down to a small area, and would direct the observer's gaze straight to the star. There may also have been, at the very time of observation, a temporary revival of the brightness of the star as has been recorded in the case of one or two objects of the same class. The legend, whether well founded or not, seems to have some astronomical verisimilitude, and at any rate suggests a mode in which an actual star could have seemed to stand over the place where the young Child lay. It would also explain what seems to have been implied in the narrative, how it happened that the Magi alone, and not the Jews in general, perceived the star at its second appearance.

Yet it seems safer to conclude that the narrative has been purposely left—astronomically—too incomplete for any astronomical

### 9. Lesson of the Narrative

conclusion to be drawn from it. One verse more, and that a short one, could have answered all our inquiries, could have told us whether the star was a conjunction of the planets, a comet, or a temporary star; or whether it was a supernatural light like the pillar of fire in the wilderness. But that verse has not been given. The score of additional words which could have cleared up the matter have been withheld, and there can be no doubt as to the reason. The star, whatever its physical nature, was of no importance except as a guide to the birthplace of the infant Jesus. The reticence of the gospel narrative on all points, except those directly relating to Our Lord Himself, enforces the truth that the Scriptures were not written to instruct us in astronomy, or in any of the physical sciences, but that we might have life eternal (Jn 17 3).

E. W. MAUNDER  
STAR OF WORMWOOD. See WORMWOOD.

STARS, COURSES OF. See ASTRONOMY, I, 1.

STARS, FALLING; MORNING; WANDERING. See ASTRONOMY, I, 8; I, 7; I, 9.

**STARS, SEVEN.** See ASTRONOMY.

**STATELY**, stāt'li (כְּבִדָּה, *k'bhūddāh*, "weight," "honor," "wealth"): "And sit upon a stately [magnificent] bed" (Ezk 23 41).

**STATER**, stā'tēr (στατήρ, *statēr*): Used only once, Mt 17 27, where it is rendered by "piece of money" in AV and "shekel" in RV. It was originally a standard Gr weight equal to two drachmas, but later it was used to designate the tetradrachma, and this is probably the coin referred to in the above passage. See MONEY.

**STATURE**, sta'tūr (מִדָּה, *madh*, מְדִינָה, *middāh*, "measure" [Nu 13 32, etc], קִמְיָה, *kōmāh*, "standing up" [1 S 16 7, etc]; ἡλικία, *hēlikia*, "greatness"): This last word means "height of the body," "stature," in Lk 2 52; 19 3; Eph 4 13, but it can mean "length of life" equally well and has this force in Jn 9 21.23; He 11 11. And this meaning, not "stature" (as in AV), is fixed for Mt 6 27|| Lk 12 25, for to add some 18 inches (see CUBIT) to one's "stature" would be a grotesque feat, while it is the smallness of the act that is emphasized. Hence the tr "able to extend his long path of life by a single cubit" (RV "measure of life"). Cf also "great of stature," Bar 3 26 (εὐμεγέθης, *eumegēthēs*).

BURTON SCOTT EASTON

**STAVES**, stāvz (בָּרִים, *baddīm*): Ten or eleven Heb words are used in the OT to describe various staffs, bars, and wooden rods used by the Hebrews (cf STAFF; ROD; SCEPTER). One word only is used to describe the staves or wooden poles used for carrying the holy furniture of the tabernacle from place to place. That word is *badh* (pl. *baddīm*), which occurs 28 t in Ex and Nu and 5 t in K and Ch (cf also Job 17 16; Hos 11 6). The only passage in which these staves are mentioned by another name is 1 Ch 15 15, where the staves used for carrying the ark from its captivity into Jerus are called *mōtāh*. The reason for this probably is that the original *baddīm* had been lost during the long absence of the sacred chest from its home in the tabernacle.

In the wilderness wanderings, arrangements were made that four items of the holy furniture of the portable tabernacle should be carried on the shoulders of Levites, suspended on these staves. These were the golden altar of incense, the golden table for shewbread, the brazen altar of sacrifice, and the ark of the covenant (Ex 35 12-16).

In the case of the large altar of sacrifice, which was in reality a hollow wooden chest covered with brass (bronze) plates (see ALTAR), four rings were attached to the brass grating which rose midway in the chest, and through these rings the staves passed. The staves were of acacia wood and were covered with brass plating. In the case of the three golden utensils of the sanctuary, the staves were of acacia wood, covered with gold plates.

The last mention of any of these staves is in 1 K 8 7-9, where it is stated of the ark, in the holy of holies in Solomon's Temple, that the ends of its staves were seen by anyone standing in the adjoining holy place, before (i.e. east of) the oracle. Priests only might view them there, the curtain being withdrawn. The writer of 1 K 8 adds that the staves were thus visible when he wrote, an item of evidence worthy of note as to the date of the document.

W. SHAW CALDECOTT

**STAY**, stā: Is derived from two distinct forms. From one derivation it has the meaning "to stand" and so "to continue in one place" (Gen 8 10; Lev 13 23.28, etc), "to forbear to act" (Ruth 1 13), "to rest," "to be trustful" (AV, ERV Isa 10 20;

see below). Transitively it means "to cause to stay," "to hinder" (Dnl 4 35, etc), and "stay" as a noun means "cessation of progress" (Lev 13 5.37), "sojourn." From the second derivation the vb. means "to support" (Ex 17 12; 1 K 22 35; Cant 2 5), while the noun means "a support" (1 K 10 19; Isa 3 1, etc). ARV has judged obsolete "stay on" in the sense "trust in," and for "stay" has substituted "lean" in Isa 10 20 and "rely" in 30 12; 31 1; 50 10, although "stay themselves upon" (= "support themselves by") has been kept in 48 2. Otherwise RV has made few alterations. But such as have been made ("tarry ye" for "stay yourselves" in Isa 29 9 and ARV "restrain" for "stay" in Job 37 4) could have been carried farther with advantage.

BURTON SCOTT EASTON

**STEAD**, sted, **STEADS**, stedz (טַהַת, *taḥath*, "[same] place"; AS *stede*, "place"): Occurs only in 1 Ch 5 22, "They dwelt in their stead [place] until the captivity."

**STEALING**, stē'ling. See CRIMES; PUNISHMENTS.

**STEDFASTNESS**, sted'fast-nes: (1) στερέωμα, *sterēōma*, "firmness": "The stedfastness of your faith in Christ" (Col 2 5). Some take this figuratively, in a military sense, of a "solid front" (see Thayer, *Gr-Eng. Lex of NT*, s.v.). (2) στεριγμός, *sterigmós*, "stability" (2 Pet 3 17; cf 1 Cor 15 58).

**STEEL**, stēl: RV substitutes "brass" for "steel" in 2 S 22 35; Job 20 24; Ps 18 34; Jer 15 12, and "steel" for "torches" in Nah 2 3. See BRASS.

**STEPHANAS**, stēf'a-nas (Στεφάνος, *Stephanós*): The name occurs only in 1 Cor 1 16; 16 15-18. Stephanas was a Christian of Corinth; his household is mentioned in 1 Cor 16 15 as the first family won to Christ in Achaia, and in 1 Cor 1 16 as among the few personally baptized by Paul at Corinth. The "house of Stephanas," apparently of independent means, had "set themselves to minister unto the saints" (1 Cor 16 15), i.e. to do Christian service. Possibly this service consisted in putting their house at the disposal of the Christians at Corinth for worshipping, or in rendering especial assistance in establishing intercommunication between the Corinthian church and the apostle, or the other churches. An instance of such service was the commission of S. at Ephesus referred to in 1 Cor 16 17.18. At the occasion of some disorders in the Corinthian church S., with Fortunatus and Achaicus in the deputation, brought a letter of the Corinthians to Paul. Our present 1 Cor is the reply to this letter, and thus, in all probability, the three men mentioned above were the bearers of this ep. With fine courtesy Paul expresses his appreciation for this service in 1 Cor 16 18, referring to it as a cherished opportunity of fellowship with his beloved Corinthians through these representatives. It is in consideration of such Christian service that Paul enjoins upon the Corinthians to show the house of S. that respect and deference due to Christian leaders by willingly submitting to their direction.

S. D. PRESS

**STEPHEN**, stē'v'n (Στέφανος, *Stēphanos*, "crown" [Acts 6 5-8 12]):

1. His Personal Antecedents
2. His Character and Activity
3. His Teaching
4. His Arraignment before the Sanhedrin
5. His Defence before the Sanhedrin
  - (1) Personal Defence
  - (2) Defence of His Teaching
6. Martyrdom of Stephen

LITERATURE



Known best as the proto-martyr of the Christian church, introducing the heroic period of persecutions. He deserves as well to be called the first great apologist for Christianity, since it was this that brought on his death as a martyr (c 36 or 37 AD).

As his name and his relations in the church at Jerus seem to imply (Acts 6 3 ff), he was a Hellenist, i.e. a Greek-speaking Jew. Thus he **1. Personal** belonged to that class of Jews usually **Antecedents** residing outside of Pal who, though distinguished from the orthodox Palestinian Jew by a broader outlook on life due to a more liberal education, were Jews none the less, the original Jewish element predominating in their character, and who might be true Israelites indeed, as Stephen was. Of his conversion to Christianity we know nothing, though there is a tradition that he was among the Seventy. As Stephen by his life and work marks a period of transition in the development of the early Christian church, so his name is connected with an important new departure within the organization of the church itself, viz. the institution of the office of the Seven (Acts 6 1 ff), who were intrusted with the administration of the work of relief in the church at Jerus—the foundation of the diaconate (Iren., *Haer.*, i.26; Cyprian, *Epist.*, iii.3). Of the seven men, all Hellenists, elected to this office at the occasion of a grievance of the Hellenistic Christians in the Jerus church against the Heb Christians, to the effect that in the distribution of alms their widows were being discriminated against, Stephen, who heads the list, is by far the most distinguished.

Stephen more than met the requirements of the office to which he was elected (Acts 6 3); the record characterizes him as "a man full of faith and of the Holy Spirit" (Acts 6 5), i.e. of an enthusiastic faith and of a deep spirituality, and his activity was not restricted to the functions of his office; in fact while nothing is said of the manner in which he fulfilled the duties of his office, though without doubt he fulfilled them faithfully, the record makes it very clear that the importance of Stephen lay in his activity as a preacher, a witness for Christ; it is this activity which has given him the place he holds in history (Acts 22 20). In itself that is not surprising, for in the early Christian church every Christian was at once a witness for Christ, and lay-preaching was common. The Seven from the first were occupied with essentially spiritual work, as also the later diaconate was engaged in something far different from mere charity organization. But Stephen was esp. qualified for this high work, having been endued by the Holy Spirit with apostolical gifts, not only that of preaching, but also that of working miracles (Acts 6 8). In his freer views of Jewish law and customs, due to his deeper conception and better understanding of the essence of Christianity, he even excelled the apostles.

He burst the bonds of Judaism, by which the other apostles were still bound, by teaching that the temple and the Law of Moses were **3. Teaching** evanescent and that Christianity was destined to supersede Judaism (Acts 6 14). These freer views of Stephen, though possibly attributable to his Hellenic culture, were certainly not of Hellenistic origin, for just their promulgation is what brought him into controversy with the Hellenistic synagogues of Jerus. Though the Hellenist dispensed himself from keeping all of the Pharisaic additions to the Law, he always regarded the Law of Moses and the temple at Jerus as highly as the Palestinian Jew. Even Philo characterizes the Law of Moses in distinction from the laws of other nations, as steadfast, immov-

able and unchangeable, placing it on a level with the laws of Nature. The true source of Stephen's freer views of the Mosaic Law and the temple was Christ's own teachings, Stephen showing a wonderfully ripened understanding of them, paralleled only by that of Paul some time later. Christ's words regarding the temple (Jn 4 20-24; Mk 13 2) not only led Stephen to see that the true worship of God was not confined to the temple, but opened his eyes as to the purely formal character of this worship in that day, which, far from being true worship, had become a mere ceremonialism (Mk 7 6), and in the words of Christ (Jn 2 19) he saw an intimation of the new temple which was to take the place of the old. Thus also his conception of the transitory nature of the Mosaic Law may be traced to Christ's teaching as to the Sabbath, the laws of purifying, the fulfilment of the Law and Jewish customs of the day (Mt 5 20) and of a better righteousness than that of the Pharisees and scribes (Mt 9 16). As Christ had been drawn into controversy with Pharisees and scribes on account of these freer views, and as His word about the temple was used to frame the accusation against Him in His trial, so also in the case of Stephen. He did not hesitate to preach his views, choosing the Hellenistic synagogues for this purpose, and soon became engaged in controversies there. But, as the record says, his opponents "were not able to withstand the wisdom," i.e. better understanding, convincing knowledge, "and the Spirit," i.e. the deep earnestness and spirituality, "by which he spake" so convincingly (Acts 6 10; Mt 10 19.20). Seeing themselves beaten, they took recourse to the ignoble method of declaring him a blasphemer and a heretic, by using the same foul means that the enemies of Jesus had resorted to, by suborning false witnesses to the plot, by stirring up the people against him, by appealing to their Jewish prejudices and to the scribes and elders, members of the Sanhedrin, and thus eventually brought about his arraignment.

The accusation which they brought against him, through the introduction of false witnesses, included a twofold charge, one against his **4. Arraign-** person, a charge of blasphemous words **ment before** against Moses which would make him **the San-** also a blasphemer of God, and one **hedrin** against his teaching, charging him with revolutionary and radical statements concerning the temple and the Law (cf Mk 14 58; 13 2; 15 29).

"Customs of Moses" (Acts 6 14) were the institutions that distinguished the Jews and that were derived from Moses. By his reference to "this place" and "these customs" Stephen was understood to imply the destruction of the temple and the change of the Law, Christianity thus aiming not only at the overthrow of the Jews' religion but the very termination of their national existence.

The charge against Stephen's person was a baseless accusation. There was no blasphemy on the part of Stephen, save by perversion of his words. The charge against his teaching was both false and true. It was false as an implied insinuation that he impugned the Divine origin and character of the temple and the Mosaic Law, but it was true as far as he conceived both to be only of a temporary nature and serving a merely provisional purpose, which, as we have seen, constituted the peculiarity of his teaching. As in the trial of Christ, the judge, Pontius Pilate, read his true verdict, "I find no guilt in him," written on His countenance and whole bearing, thus here the record tells us that the judges of Stephen, "All that sat in the council . . . saw his face as it had been the face of an angel" (Acts 6 15; 2 Cor 3 18); as if in refutation of the charge made against him, Stephen receives the

same mark of Divine favor which had been granted to Moses. It is a significant fact that Stephen was not arraigned before the Sanhedrin as being a Nazarene, though at bottom it was the real cause of his arraignment. Thus also his defence before the Sanhedrin, though the name of Jesus was not mentioned until the very last, was in reality a grand apology for Christ.

While the assembly was overawed by the evidence of singular innocence and holiness written upon the countenance of Stephen

**5. Defence** (Acts 6 15), the question of the high before the priest "Are these things so?" broke in Sanhedrin upon the silence. It drew forth from Stephen that masterful pleading which, so sublime in form and content and bare of all artificiality, belongs to the highest type of oratory, characterized by its deep, earnest, and genuine spirituality, the kind of oratory of which the great speeches of our own martyred Lincoln were models. It is not so much a plea in self-defence as a grand apology for the cause which Stephen represents.

Beginning by mentioning "the God of glory" and ending with a vision of that glory itself, the speech is a wonderful apotheosis of the humble cause of the Nazarene, the enthusiastic tribute of its first great martyr delivered in the face of death. The contents of his speech are a recital of the most marked phases of Jewish history in the past, but as read from the point of view of its out-workings in the present—old facts interpreted by a spirit-filled disciple of Christ. It is in reality a philosophy of Israel's history and religion, and in so far it was a *novum*. Thus the new feature that it furnishes is its philosophy of this history which might be termed the Christian philosophy of Jewish history. In appealing to their reason he calls up picture after picture from Abraham to Moses; the speech exhibits vividly the continuity and the progress of the Divine revelation which culminated in Jesus of Nazareth, the same thought as that expressed by Christ in Mt 5 17 of the principal agreement between the OT and the NT revelation.

The emotional appeal lies in the reverential and feeling manner in which he handles the history sacred to them all. The strong appeal to the will is made by holding up the figure of Moses' type of the Law, in its vital significance, in such a way as passionately to apply it to the fundamental relation of Divine plan and human conduct. Thus the aim of Stephen was to point out to his hearers the true meaning of Jewish history and Jewish Law in reference to the present, i.e. in such a way that they might better understand and judge the present and adjust their conduct to it accordingly. Their knowledge of Jewish history and Jewish religion as he would convey it to them would compel them to clear him of the accusation against him as blasphemer and false teacher.

In accordance with the accusation against him, his defence was a twofold one: personal defence and defence of his teaching.

(1) *Personal defence*.—The charge of blasphemy against God and contempt of the Law is implicitly repudiated by the tenor of the whole speech. The courteous and at once endearing terms in Stephen's address (Acts 7 2) to the council, and the terms "our fathers" and "our race" in vs 2.19 by which he closely associates himself with his hearers, his declaration of the Divine majesty of Jeh with which the speech opens (ver 2), of the providential leading of the patriarchs (vs 8.10), his recognition of the OT institutions as Divinely decreed (ver 8), his reference to the Divine sanction of the Law and its condemnation of those who had not kept it (ver 53), at the close of his speech, show clearly his reverence, not only for the past history of the Jewish race, but as well for its Sacred Writings and all of its religious institutions. It makes evident beyond doubt how ungrounded the accusation of blasphemy against him was. Not to impiety or frivolity in Stephen, but to some other cause, must be due therefore the difference between him and his opponents. What it is Stephen himself shows unmistakably in the second part of his defence.

(2) *Defence of his teaching*.—The fundamental differences between Stephen and his opponents, as is

evident from the whole tone and drift and purpose of his speech, lay in that he judged OT history from the prophetic point of view, to which Jesus had also allied Himself, while his opponents represented the legalistic point of view, so characteristic of the Jewish thought of that day. The significance of this difference is borne out by the fact upon which Stephen's refutation hinges, viz. the fact, proved by the history of the past, that the development of the Divine revelation and the development of the Jewish nation, so far from combining, move in divergent lines, due to a disposition of obstinate disobedience on the part of their fathers, and that therefore not he but they were disobedient to the Divine revelation. Thus in a masterful way Stephen converts the charge of Antinomianism and anti-Mosaism brought against him into a counter-charge of disobedience to the Divine revelation, of which his hearers stood guilty in the present as their fathers had in the past. In this sense the speech of Stephen is a grand apology for the Christian cause which he represented, inasmuch as it shows clearly that the new religion was only the Divinely ordered development of the old, and not in opposition to it.

The main arguments of the speech may be summed up as follows: (a) God's self-manifestation to Israel in revealing His covenant and His will, so far from being bound to one sanctuary and conveyed to one single person (Moses), began long before Moses and long before there was a temple. Thus it was gradual, and as it had begun before Moses it was not completed by him, as is evident from his own words, "A prophet shall God raise up unto you from among your brethren, like unto me" (Acts 7 2-37).

(b) The Jews to whom these revelations were granted, so far from being thankful at all stages of their history, had been slow to believe and understand them because they "would not be obedient" (vs 39.57). They resisted the purpose of God by obstinately and stiff-neckedly opposing those through whom God worked. Thus their fathers had turned away from Moses at the very moment when he was receiving God's greatest revelation, and, instead of obeying the "living oracles" (ver 38) he gave them, turned to idol-worship for which God punished them by the Bab captivity (vs 39-43). They had killed the prophets who had protested against the dead ritualism of the temple-worship and raised their voice in behalf of a true spiritual worship as that of the tabernacle had been (vs 44-50.52). This disposition of disobedience so characteristic of the race in its whole history, because, in spite of the Divine revelation received, they remained unregenerate (ver 51), reached its culmination in that awful crime of betrayal and murder committed by the present generation upon the "Righteous One" whose coming the prophets had predicted—the rejection of Jesus of Nazareth, by which the Jews doomed not only their national existence, but also their temple-worship and the reign of the Law to destruction (7 52-6 14).

Though the name of Jesus was not uttered by Stephen in his speech and does not occur until in his dying prayer, his hearers could not fail to notice the hidden reference to Him throughout the entire speech and to draw parallels intended by Stephen: As Joseph and Moses, types of the Messiah, had been rejected, scorned and ill-treated (Acts 7 9.27.39), before being raised to be ruler and deliverer, so Jesus had also been repulsed by them.

The climax of his speech is reached in vs 51-53, when Stephen, breaking off the line of argument, suddenly in direct address turns upon his hearers, and, the accused becoming the accuser, charges them openly with the sin of resisting the Holy Spirit, with the murder of the prophets and the Righteous One, and with continual disobedience to the Law. These words which mark the climax, though probably not the close of the speech, pointed the moral in terms of the most cutting rebuke, and were at once prophetic as to the effect the speech would have upon his hearers and for him.

Such arguing and directness as Stephen's could have but one result. Prejudiced and enraged as they were, the unanswerable arguments of Stephen, based on their own Scriptures, made them mad with fury, and doubtless through their demonstrations they stopped the speech. But Stephen,

transported with enthusiasm and inspiration, was vouchsafed a vision of the "glory of God," which he had mentioned in the beginning of his speech (7 2), and of Jesus, whose cause he had so gallantly defended (ver 55). Stephen standing there, his gaze piercing into heaven, while time and human limitations seemed effaced for him, marks one of the most historic moments in the history of Israel, as his words constitute the most memorable testimony ever uttered in behalf of Christ: "Behold, I see the heavens opened, and the Son of man"—the only place where this title is uttered by any other person than Jesus—"standing on the right hand of God" (ver 56). Now the audience could restrain its rage no longer, and the catastrophe followed immediately. Contrary to Rom law and order they took Stephen, and without awaiting sentence against him, amid a tumultuous scene, stoned him to death, the punishment prescribed in Mosaic Law for a blasphemer (Dt 17 7; Lev 24 14-16). This recourse to lynch law may have been connived at by the Rom authorities, since the act was without political significance. It is noteworthy, however, that the Jewish legal forms were observed, as if to give to the violence the appearance of legality. Accordingly, Stephen was taken outside the city (Lev 24 14; cf Lk 4 29); the witnesses threw the first stone at him (cf Dt 17 7) after taking off their upper garments and laying them at the feet of a "young man named Saul" (Acts 7 58)—afterward Paul, now about 30 years old—who evidently had charge of the whole proceedings.

Stephen died as he had lived, a faithful witness to his Master whom he acknowledged as such amid the rain of stones hurled at him, loudly calling upon His name, "Lord Jesus, receive my spirit" (Acts 7 59; cf Lk 23 46), and whose spirit he exemplified so nobly when, with a final effort, bending his knees, he "cried with a loud voice, Lord, lay not this sin to their charge" (Acts 7 60; cf Lk 23 34). "And when he had said this, he fell asleep" (7 60; cf 1 Cor 15).

The impression made by Stephen's death was even greater than that made by his life. Though it marks the beginning of the first great persecution of Christians, the death of the first Christian martyr resulted in the greatest acquisition Christianity has probably ever made, the conversion of Saul of Tarsus. The vision of the risen and exalted Jesus vouchsafed to the dying Stephen presented Christianity to Saul of Tarsus in a new light, tending to remove what had been its greatest stumbling-block to him in the Crucified One. This revelation coupled with the splendid personality of Stephen, the testimony of his righteous life and the noble bravery of his sublime death, and above all his dying prayer, fell upon the honest soul of Saul with an irresistible force and inevitably brought on the Damascus event, as Augustine clearly recognized: "Si Stephanus non prasset, ecclesia Paulum non habuisset." Judged by his teaching, Stephen may be called the forerunner of Paul. He was one of the first to conceive of the fact that Christianity represented a new order of things and as such would inevitably supersede the old order. Thus his teachings forecast that greatest controversy of the first Christian century, the controversy between Judaism and Christianity, which reached its culmination-point in the Council of Jerus, resulting in the independence of the Christian church from the fetters of Judaistic legalism.

LITERATURE.—R. J. Knowling, "Acts" in *Expositor's Gr Test.*, II (1900); Feine, *PREB.*, XIX (1907); Pahncke in *Studien u. Krit.* (1912), I.

S. D. PRESS

STEWARD, stü'erd (אִישׁ עַל בַּיִת, 'ish 'al bayith [Gen 43 16.19; 44 1; 1 K 16 9], הַמְלָצָר, ha-melçar [Dnl 1 11], הַסֹּכֵן, ha-sôkhên

1. OT  
Usage

is found in Gen 15 2; 1 Ch 28 1, in addition to the above. ARV renders Gen 15 2 as "possessor," and 1 Ch 28 1 "rulers."

The phrase *ben-meshek* in Gen 15 2 is best rendered "son of acquisition," hence "heir." But this is disputed. Skinner in the *ICC* on Gen regards the text as hopelessly corrupt, and offers no solution of the difficulty. In the other passages, the phrase 'ish 'al bayith is conveniently tr<sup>d</sup> "steward," though lit. it is "man over the house." The word *ha-melçar* in Dnl 1 11 is tr<sup>d</sup> in AV as a proper noun. This is certainly a mistake. The margin gives "the steward," and this is followed in RV. A better rendering perhaps would be "overseer," as this man seemed to have the superintendence of the training and feeding of the young men until they were fitted to enter the king's service. He was thus rather a steward of persons than of property (see MELZAR). In Isa 22 15 Shebna is described in the text as "treasurer," but in the margin as "steward," and seems to combine the ideas in both the words "treasurer" and "steward." Shebna was thus one of the highest officials, having charge of the city's funds, and of administering them for the city's benefit.

Though the word for "steward" occurs but once in that sense, the idea is one familiar to the OT. Eliezer of Damascus was Abraham's slave and trusted steward. He seems to have had the oversight of all his affairs and was intrusted with the important duty of getting a wife for Isaac. He apparently had charge over the family of his master as well as his property. Whether Isaac had such a steward or not is nowhere stated, but it is practically certain that he had. Jacob seems to have been Laban's steward for a time, as he apparently had full charge of the flocks and herds of his master. Joseph was practically Potiphar's steward, and when he became Pharaoh's chief minister, he himself had a steward over his own house (Gen 39 4.5; 44 1.4). The king Elah in his brief reign of two years had a steward in charge of his household (1 K 16 9). The same was doubtless true of all the kings, and it may be safely inferred that every household of distinction or of sufficient wealth had a steward in charge. The functions of this officer seem at times to have included the care of the children or minors, as well as of the property. Sometimes he was a slave, sometimes a freedman.

ἐπιτροπος, *epitropos*, οἰκονόμος, *oikonomos*. These two terms denote similar positions. The exact difference cannot be clearly defined, as

2. In the NT they are sometimes almost synonymous. The two are found together in Gal 4 2. Some scholars say they are used synonymously, others that the first word is a more general term including the latter. Lightfoot and Eliott think that the former refers rather to the guardianship of persons, the child's legal representative, while the latter word refers to the head servant appointed to manage the household or property (cf 2 Macc 11 1; 13 2). There would, however, not be any such hard-and-fast line between their respective duties; these might vary with every master, or might be combined in one individual.

(1) *In the Gospels.*—The idea seems to have been perfectly familiar to the people in Christ's day. Every household of distinction seems to have had a steward in charge, Herod's steward was named Chuzas, and his wife, Joanna, followed and ministered to Jesus (Lk 8 3). The word *epitropos* used here is held by some scholars to imply that he had charge of the education of Herod's children. This is very probable but not certain. In the parable of the Laborers in the Vineyard, it is the steward who pays the laborers at the close of the day (Mt 20 8). The parable of the Unjust Steward best illustrates the practice. This steward was a

freeman, had full charge of his master's affairs and could use them to his own advantage if he chose, was fully accountable to his master and had to render an account when called upon. If unfaithful he was usually discharged at once (Lk 16 1-13). The parables of the Minae or Pounds (Lk 19 12-27), the Talents (Mt 25 14-30), and the Wicked Husbandmen (Mt 21 33-46) teach similar truths. In His warning to His disciples Jesus seems to imply that they were to act as stewards in His absence (Lk 12 42). According to this passage a steward's task was to manage all the affairs of his master, attend to receipts and expenditures, and portion out to each one of the household what should come to him. The disciples were left thus in charge of His gospel and were to use this gift to the best advantage in behalf of others until His return. In Jn 2 8 the term "ruler" is given in the margin as "steward." The one referred to here was really director of the feast rather than steward, though in a sense charged with the responsibility of conducting it. Many stewards were no doubt slaves, as is implied in Mt 24 45, while others were freedmen (Lk 16 1-21).

(2) *In the Epistles.*—The application of this term is largely confined to the ministry of the gospel. Paul and his fellow-laborers regarded themselves as stewards of the mysteries of God (1 Cor 4 1.2). The idea is that he take scrupulous care of that which was intrusted to him, and give it out to others faithfully and as directed by his master Jesus Christ. A bishop or overseer is to be as God's steward (Tit 1 7). Peter considered himself and all other Christians as "stewards of the manifold grace of God" (1 Pet 4 10). The prevalence of the custom of having guardians and stewards over children in their minority is shown in Gal 4 2. The difference in meaning of the two words used here is stated above. In Rom 16 23 Erastus is called the *oikonomos* of the city. This is best tr'd "treasurer." Erastus was thus an influential member of the community of Corinth and evidently a faithful Christian.

JAMES JOSIAH REEVE

**STEWPAN**, stū'pan (Lev 11 35 m). See PAN.

**STIFF-NECKED**, stif'nekt (קָשָׁה עֵרֶף, *k'shēh 'oreph*, lit. "hard of neck"): As it is figuratively used, both in the OT and in the NT, the word means "stubborn," "untractable," "not to be led." The derivation of the idea was entirely familiar to the Jews, with whom the ox was the most useful and common of domestic animals. It was esp. used for such agricultural purposes as harrowing and plowing (Jgs 14 18; 1 Cor 9 9).

The plow was usually drawn by two oxen. As the plowman required but one hand to guide the plow, he carried in the other an "ox-goat." This was a light pole, shod with an iron spike. With this he would prick the oxen upon the hind legs to increase their speed, and upon the neck to turn, or to keep a straight course when deviating. If an ox was hard to control or stubborn, it was "hard of neck," or stiff-necked. Hence the figure was used in the Scriptures to express the stubborn, untractable spirit of a people not responsive to the guiding of their God (Ex 32 9; 33 3; Dt 9 6; 2 Ch 36 13; Jer 17 23, etc.). See also the NT where σκληροτράχηλος, *sklērotráchēlos*, is so tr'd (Acts 7 51), "Ye stiff-necked and uncircumcised in heart and ears, ye do always resist the Holy Spirit." Cf Bar 2 30.33.

ARTHUR WALWYN EVANS

**STILL**, stil: "To be still" is "to keep silence" (Ps 4 4, etc.) and so "to be quiet" (Ps 107 29, etc.) or "inactive" in any way (Jgs 18 9; 1 K 22 3; Zec 1 11, etc.). So "be still" in Ps 46 10 means "desist from your war" (cf RVm "let be"). The

"still small voice" of 1 K 19 12 (RVm "sound of gentle stillness") is due to taking the Heb *d'māmāh* in its literal force of "silent," but the word here means "whisper"—"a whispering, little voice." This familiar passage, however, has made "still voice" good Eng., and the combination is used in Job 4 16 by RVm. In Ps 23 2 the tr "still waters" takes "waters of rest" (so lit. for מִי־יְהִיָּהּ, *m'nyhāh*; cf RVm) to mean "waters with little motion." But the meaning is either "wells by which the flocks rest" or "wells that give refreshing water." As an advb. "still" is perhaps more emphatic than in modern Eng.; cf "power to keep still the kingdom," 2 Ch 22 9 AV (RV "to hold the kingdom").

BURTON SCOTT EASTON

**STING**, sting (פָּרָשׁ, *pārash*, "to cut into"; κέντρον, *kéntron*, "a goad," "spur"): A sharp, pointed organ or instrument for inflicting wounds by puncture; sting of an adder, Prov 23 32; of scorpions, Rev 9 10. In the free quotation of 1 Cor 15 55 from Hos 13 14, death is personified as a deadly animal, like a scorpion or serpent, which inflicts destruction by means of sin as its *kéntron*. It should also be remembered that in Acts 26 14 the same Gr word is used with reference to an instrument for exciting fear, rather than death. Both figures are pertinent; for death is powerless, except through sin, and, also, when sin is vanquished, the fear of death (He 2 15) is gone. H. E. JACOBS

**STIR**, stûr, **STIR UP**: Used transitively and intransitively to indicate inner, concentrated movement; translates a number of Heb and Gr vbs., each of which has its different shade of meaning. Thus e.g. in Ps 39 2, we have 'akhar, "to be troubled," "excited"; in Cant 2 7, 'ur, "to awake," "disturb" (by the festal dances and songs). In 2 Tim 1 6, it stands for Gr *anazōpurēō*, used of the resuscitation of a flame; in 2 Pet 1 13; 3 1, Gr *diegetrō*, "to awaken from sleep or stupor"; in Acts 21 27, Gr *sugchēō*, "to commingle," vividly portraying the confusion and tumult that resulted; in Acts 13 50, Gr *parotrūnō*, "to urge on"; Acts 17 13, Gr *saleiō*, "to shake to and fro."

**STOCK**, stok: In EV is used for:

(1) The stem of a tree, whether alive (Job 14 8; Isa 40 24) or cut down (Isa 44 19; Wisd 14 21). In Jer 2 27; 3 9; Hos 4 12, where the Heb has simply עֵץ, 'ēz, "wood," either meaning is possible (tree-worship? idolatry?). In Jer 10 8 the text is doubtful.

(2) A family (Lev 25 47; 1 Esd 5 37; Tob 5 13; 1 Macc 12 21; 2 Macc 1 10; Acts 13 26; Phil 3 5).

(3) Elsewhere (Job 13 27, etc) the word refers to an instrument of punishment. See PUNISHMENTS.

**STOICS**, stō'iks (Στωϊκοί, *Stōikoí*):

1. Origin and Propagation
2. Metaphysics and Religion
3. Sensationalist Epistemology
4. Ethical Teaching
5. Relation to Christianity

#### LITERATURE

The name was derived from the *Stoa Poikilē*, the painted porch at Athens, where the founders of the school first lectured. This school

1. Origin of Gr philosophy was founded at and Propagation Athens c 294 BC by Zeno (c 336-264 BC), a native of Citium, a Gr colony in Cyprus. But the Sem race predominated in Cyprus, and it has been conjectured that Zeno was of Sem rather than Hellenic origin. His Gr critics taunted him with being a Phoenician. It has therefore been suggested that the distinctive moral tone of the system was Sem and not Hellenic.

Further color is given to this view by the fact that Zeno's immediate successors at the head of the school also hailed from Asia Minor, Cleanthes (331-232 BC) being a native of Assos, and Chrysippus (280-206 BC) of Soli in Cilicia. Several other adherents of the system hailed from Asia Minor, and it flourished in several Asiatic cities, such as Tarsus and Sidon. In the 2d cent. BC the doctrine was brought to Rome by Panaetius of Rhodes (c 189-109 BC), and in the course of the two succeeding centuries it spread widely among the upper classes of Rom society. It reckoned among its adherents a Scipio and a Cato, Seneca and Marcus Aurelius, as well as the freedman Epictetus. The most adequate account of the teaching of the Gr Stoics has been preserved in the writings of Cicero, who, however, was a sympathetic critic, rather than an adherent of the school. The system acquired its most lasting influence by its adoption as the formative factor in the jurisprudence of imperial Rome, and Rom law in its turn contributed to the formation of Christian doctrine and ethics.

The main principles of Stoicism were promulgated by Zeno and Cleanthes, and Chrysippus

**2. Meta-** doctrine which became a standard of physics and orthodoxy for the school, and which **Religion** permitted but little freedom of speculation for its subsequent teachers.

Whatever may have been the Sem affinities of mind of Zeno and his followers, they derived the formal principles of their system from Gr antecedents. The ethical precept, "Follow Nature," they learnt from the Socratic school of Antisthenes, the Cynics. But they followed the earlier philosopher Heraclitus in defining the law of Nature as reason (*lógos*), which was at once the principle of intelligence in man, and the Divine reason immanent in the world. This doctrine they again combined with the prevalent Gr hylozoism, and therefore their metaphysics inclined to be a materialistic pantheism. On the one side, Nature is the organization of material atoms by the operation of its own uniform and necessary laws. On the other side, it is a living, rational being, subduing all its parts to work out a rational purpose inherent in the whole. As such it may be called Providence or God.

While the Stoics rejected the forms and rites of popular religion, they defended belief in God and inculcated piety and reverence toward Him. Their pantheism provided a basis for Gr polytheism also alongside of their monism, for where all the world is God, each part of it is Divine, and may be worshipped. Another consequence of their pantheism was their attitude to evil, which they held to be only apparently or relatively evil, but really good in the harmony of the whole. Therefore they bore evil with courage and cheerfulness, because they believed that "all things worked together for good" absolutely.

The materialistic trend of their metaphysics also comes out in their epistemology, which was sensationalist.

**3. Sensa-** The human mind at its birth was a *tabula* **Episte-** *rasa*. Its first ideas were derived from mology impressions made by the external world upon the soul, which they also conceived as a material body, though made of finer atoms than the external body. Out of these sense-impressions the mind built up its intuitions or preconceptions, and its notions, which constituted its store of ideas.

It is not clear how far they attributed originative power to the mind as contributing some factor to the organization of knowledge, which was not derived from experience. The Stoic system is never consistently materialistic, nor consistently idealistic. Most of its terms are used in a dual sense, material and spiritual.

But its ethical teaching shows that the main trend of the system was spiritualistic. For its crown and climax was the ethics. The

**4. Ethical** Stoics did not pursue knowledge for Teaching its own sake. They speculated about ultimate problems only for the practical purpose of discovering a rule of life and conduct. And in their ethics, the great commandment,

"Follow Nature," is interpreted in a distinctly idealistic sense. It means, "Follow reason," as reason inheres both in man and in the universe as a whole. It is submission to Providence or the rational order of the universe, and the fulfilment of man's own rational nature. The life according to Nature is man's supreme good. How actual Nature could be the ideal good that man ought to seek, or how man was free to pursue an ideal, while he was bound in a system of necessity, were fundamental paradoxes of the system which the Stoics never solved. They summed up their moral teaching in the ideal of the sage or the wise man. His chief characteristic is ataraxy, a calm passionless mastery of all emotions, and independence of all circumstances. He therefore lives a consistent, harmonious life, in conformity with the perfect order of the universe. He discovers this order by knowledge or wisdom. But the Stoics also defined this ideal as a system of particular duties, such as purity in one's self, love toward all men, and reverence toward God. In Stoic ethics, Gr philosophy reached the climax of its moral teaching. Nowhere else outside Christianity do we find so exalted a rule of conduct for the individual, so humane, hopeful and comprehensive an ideal for society.

When "certain . . . of the Epicurean and Stoic philosophers encountered" Paul at Athens, and

when, after the apostle had spoken on Mars' Hill, "some mocked; but to Chris-

others said, We will hear thee concerning this yet again" (Acts 17 18.32), it is no improbable inference that the Epicureans mocked, while the Stoics desired to hear more. For they would find much in the apostle's teaching that harmonized with their own views.

Paul's quotation from the classics in his Athenian speech was from the Stoic poet, Aratus of Soli in Cilicia: "For we are also his offspring."

His doctrine of creation, of Divine immanence, of the spirituality and fatherhood of God, would be familiar and acceptable to them. His preaching of Christ would not have been unwelcome to them, who were seeking for the ideal wise man. Paul's moral teaching as it appears in his Epp. reveals some resemblance to Stoic ethics. It is possible that Paul had learnt much from the Stoic school at Tarsus. It is certain that subsequent Christian thought owed much to Stoicism. Its doctrine of the immanent Logos was combined with Philo's conception of the transcendent Logos, to form the Logos doctrine through which the Gr Fathers construed the person of Christ. And Stoic ethics was taken over almost bodily by the Christian church. See EPICUREANS; PHILOSOPHY.

LITERATURE.—The chief extant sources are the writings of Cicero, *De Finibus*, *De Natura Deorum*, etc.; Seneca, Plutarch, M. Antoninus Aurelius, Epictetus, Diogenes Laertius, Sextus Empiricus and Stobaeus. Modern works: H. von Arnim, *Stoicorum veterum fragmenta*; Zeller, *Stoics, Epicureans and Sceptics*; R. D. Hicks, *Stoic and Epicurean*; W. L. Davidson, *The Stoic Creed*; E. V. Arnold, *Roman Stoicism*, which contains a full bibliography and deals with the relation of Stoicism to Christianity; on the latter point see also Lightfoot, *Phil.*, Excursus II, "St. Paul and Seneca"; histories of philosophy by Rogers, Windelband, Ueberweg, and E. Caird.

T. REES

**STOMACH**, stum'uk (στόμαχος, *stómachos*): In man and most vertebrates, a membranous sac-like portion of the alimentary canal, in which the earlier stages of digestion take place and in which food is prepared to yield its nourishment (1 Tim 5 23).

Used figuratively of *pride*, "A proud look and high stomach" (Ps 101 7, Prayer-book Version), and *courage*, "Stirring up her womanish thoughts with a manly stomach" (2 Macc 7 21 AV, RV "with manly passion").

**STOMACHER**, stum'uk-ēr: Used to translate **שְׂתֵי־יָדַיִל**, *p̄thāghīl* (Isa 3 24 AV), where the meaning is uncertain. The Eng. word denotes that part of a woman's dress which covered the breast and the pit of the stomach. It was usually much ornamented.

**STONE**, stōn, **STONES**, stōnz:

(1) Chiefly **אֶבֶן**, 'ebhen, and **λίθος**, *lithos*; but also, occurring rarely, **אֶשְׁכַּח**, 'eshekh (Lev 21 20); **צִוּר**, *çūr* (Job 22 24), usually "rock";

**1. Hebrew and Greek Words** **אֶבֶן**, *çrōr* (2 S 17 13); **πέτρος**, and **πέτρος** *pétros* (Jn 1 42); **ψήφος**, *psēphos* (Rev Words 2 17). For **צֵלָא**, *çela*, usually "cliff," "crag," "rock," AV, in Ps 137 9;

141 6, has "stone," but RV "rock." For AV "stones," **הֶרֶשֶׁת**, *heres* (Job 41 30); RV has "potsherds." See **SELA**.

The word is used of great stones (Gen 29 2); of small stones (1 S 17 40); of stones set up as memorials (1 S 7 12, "Eben-ezer,"

**2. Literal Usage** "stone of help"); of precious stones (Ex 35 9, etc); of hailstones (Josh 10 11).

Of hardness: "I will take the stony heart out of their flesh" (Ezk 11 19); of one smitten: "[Nabal's] heart died within him, and

**3. Figurative Usage** became a stone" (1 S 25 37); of weight: "A stone is heavy, and the sand weighty" (Prov 27 3); of dumbness: "Woe unto him that saith to the wood, Awake; to the dumb stone, Arise!" (Hab 2 19); of Jerus: "I will make Jerus a burdensome stone for all the peoples" (Zec 12 3); of the corner-stone as a figure of high position:

"The stone which the builders rejected  
Is become the head of the corner" (Ps 118 22).

See **FLINT**; **ROCK**.

(2) Used also anatomically of the testicles (Lev 21 20; Dt 23 1; Job 40 17, **פַּהַד**, *paḥadh*, RV "thighs").

ALFRED ELY DAY

**STONE-SQUARERS**, stōn'skwâr-ērz: AV in 1 K 5 18; RV "the Gebalites" (q.v.).

**STONES, PRECIOUS:**

1. Ancient and Modern Names
2. Change of Signification of Names
3. Three Important Lists of Stones
4. Interpretation of Greek Names Used by St. John
5. Interpretation of Hebrew Names
6. Greek and Latin Equivalents of Hebrew Names
7. Inconsistencies of Text or Translation
8. Vulgate and LXX
9. Hebrew Texts of LXX and EV
10. Equivalence of Hebrew and Greek Names
11. Interpretation of Greek Names Used by LXX
12. List of Names with Biblical References

Great difficulty is met with in any attempt to translate the Gr and Heb names mentioned in the Bible into names that would be used

**1. Ancient and Modern Names** for the same minerals in a particular country at the present day. It is only within the last century, through the development of the sciences of chemistry and crystallography, that

it has become possible to define mineral species with any considerable approach to precision. In ancient times various minerals were regarded as belonging to a single kind, and indicated by a single name, that are now distributed into different kinds and mentioned under different names.

For example, 2,000 years ago the Gr term *anthrax* was used to signify various hard, transparent, red stones that are now known to differ much from one another in chemical composition, and are therefore assigned to different species and given different names; among them are oriental ruby (red corundum), balas ruby (red spinel),

almandine and pyrope (red garnets); a stone designated *anthrax* by the ancient Greeks might thus belong to any one of a number of various kinds to the assemblage of which no name is now given, and the word *anthrax* has no simple equivalent in a modern language.

Confusion is introduced in another way. The Eng. names of most of the precious stones mentioned in the Bible are adaptations of the Gr names through the Lat; for instance, the Eng. word "topaz" is a modification of the Lat word *topazius*, itself merely a Lat form of the Gr word *topázion*. It would at first sight

appear that the Gr word *topázion* must be tr<sup>d</sup> into Eng. by the word "topaz"; but, strangely, although the words are virtually identical, the stones indicated by the words are quite different. The *topázion* of the ancient Greeks was a green stone yielding to the action of a file and said to be brought from an island in the Red Sea, whereas the topaz of the present day is not a green stone, does not yield to the action of a file, and has not been brought from an island in the Red Sea. The *topázion* of the ancient Greeks is really the peridot, not the topaz, of modern mineralogy; *topázion* and topaz are different kinds of stone. For the interpretation of the Bible it is thus necessary to ascertain, if possible, the kind of stone to which a Gr or Heb name was applied at the time when the word was written.

Most of the names of the precious stones mentioned in the Bible are contained in the Heb description of the breastplate of the high priest and the Gr description of the foundations of the New Jerusalem.

**3. Three Important Lists of Stones** The ornaments assigned to the king of Tyre (Ezk 28 13) included only stones that had been used in the breastplate; indeed, in the LXX, they are the same twelve, mentioned in precisely the same order.

The stones of the breastplate according to our Heb text (Ex 28 17-21) were:

	No. 1	No. 2	No. 3
1st row . . . . .	אֶבֶן 'odhem	פֶּטְרָה piṭṭēhāh	בָּרָקֶת bārēkēth
2d row . . . . .	נֹפֶךְ nōphekh	סַפִּיר çappīr	יָהֳלֹם yahālōm
3d row . . . . .	לֶשֶׁם leshem	שֹׁבַל shebhō	אֶהֱלָמָה 'ahlāmāh
4th row . . . . .	תַּרְשִׁישׁ tarshīsh	שֹׁהַם shōham	יָשֶׁפֶה yāshephēh

The foundations of the New Jerusalem are (Rev 21 19,20):

1	<i>iaspis</i>	2	<i>sāppheiros</i>	3	<i>chalkēdōn</i>
4	<i>smaragdōs</i>	5	<i>sardōnux</i>	6	<i>sárdion</i>
7	<i>chrusōlīthos</i>	8	<i>berullos</i>	9	<i>topázion</i>
10	<i>chrusōprasos</i>	11	<i>huakīnthos</i>	12	<i>amēthustos</i>

Only 4 of the latter stones are mentioned elsewhere in the NT, also in the Book of Rev, namely: *iaspis* (4 3; 21 18), *smaragdōs* (4 3), *sardion* (4 3) and *huakīnthos* (9 17).

For the interpretation of the Gr names used by St. John, much help is given by Pliny's great work on *Natural History*, published 77 AD,

**4. Interpretation of Greek Names Used by St. John** for it records what was known about precious stones at the very time when St. John himself was living. The Gr names of stones and their Lat verbal equivalents had presumably the same signification for both these writers; it

is thus possible, in some cases at least, to ascertain what name is now assigned to a stone mentioned in the NT if the name and description

are recorded in the treatise of Pliny; the results are given in the alphabetical list below. All twelve stones, except *chalkedon*, are mentioned by Pliny; the few important stones described by him, but not mentioned by St. John as foundations, are *crystalum* and *adamas*, both of them colorless; *onyx*, remarkable rather for structure than color; *electrum* (amber), a soft material; *carbunculus*, fiery red; *callaina*, pale green, probably turquoise; *cyanus*, dark blue; and *opalus* (opal), ranked in Pliny's time immediately after *smaragdus* in value. *Achates* (agate) is omitted, but was no longer precious.

In the interpretation of the Heb names of the stones of the breastplate there is much greater difficulty, for no Heb lit. other than

**5. Interpretation of Hebrew Names**

the OT has been preserved, and little help is afforded by the contexts of other verses in which some of the Heb names of precious stones occur. If we could assume that the LXX and Vulg VSS of the description of the breastplate were made from Heb texts absolutely identical in respect of the names of the stones with those used for the preparation of the EV, and that the VSS were correctly made, the Gr equivalents of the Heb terms for the time of the LXX translators (about 280 BC) and their Lat equivalents for the time of St. Jerome (about 400 AD) would be directly determinable by collation of the Heb original with the Gr and Lat tr<sup>s</sup>.

It must be remembered, however, that a Heb writer, in describing the arrangement of a row of stones, began with that on his right and mentioned them in the order right to left, while a western writer begins with the stone on his left and mentions them in the reverse order. Hence, in translating a Heb statement of arrangement into a western language, one may either translate literally word by word, thus adopting the Heb direction of reading, or, more completely, may adopt the western direction for the order in the row. As either method may have been adopted by the LXX translators, it follows that ' *odhem* and *bareketh*, the first and last stones of the 1st row according to our Heb text, may respectively be equivalent either to *sardion* and *smaragdus*, or, conversely, to *smaragdus* and *sardion*; and similarly for the other rows. The number of the middle stone of any row is the same whichever direction of reading is adopted. ' *Odhem* being red, and *sardion* and *smaragdus* respectively red and green (see below), ' *odhem* must be equivalent to the former, not the latter, and the LXX translators must have adopted the Heb direction of reading the rows.

Other sets of possible equivalents are derivable by collation of the Bib. description with each of the two descriptions given by Jos (*Ant*,

**6. Greek and Latin Equivalents**

	No. 1	No. 2	No. 3
1st row	Heb ' <i>odhem</i> LXX <i>sardion</i> Vulg <i>sardius</i> Ant <i>sardónuz</i> BJ <i>sárdion</i>	<i>pipédah</i> <i>ópázion</i> <i>topazius</i> <i>topázion</i>	<i>báreketh</i> <i>smáragdos</i> <i>smaragdus</i> <i>smáragdos</i>
2d row	Heb <i>nôphekh</i> LXX <i>ánthraz</i> Vulg <i>carbunculus</i> Ant <i>ánthraz</i> BJ <i>ánthraz</i>	<i>gappir</i> <i>sáppheiros</i> <i>sápphirus</i> <i>iaspis</i> <i>iaspis</i>	<i>yahálóm</i> <i>iaspis</i> <i>iaspis</i> <i>sáppheiros</i> <i>sáppheiros</i>
3d row	Heb <i>leshem</i> LXX <i>ligúrión</i> Vulg <i>ligurius</i> Ant <i>ligúrión</i> BJ <i>achátēs</i>	<i>shébhā</i> <i>achátēs</i> <i>achates</i> <i>améthustos</i> <i>améthustos</i>	' <i>ahlámāh</i> <i>améthustos</i> <i>amethystus</i> <i>achátēs</i> <i>ligúrión</i>
4th row	Heb <i>tarshish</i> LXX <i>chrusólithos</i> Vulg <i>chrysolithus</i> Ant <i>chrusólithos</i> BJ <i>onúchion</i>	<i>shóham</i> <i>bérállion</i> <i>onychinus</i> <i>onúchion</i> <i>bérállion</i>	<i>yáshēphēh</i> <i>onúchion</i> <i>beryllus</i> <i>bérállion</i> <i>chrusólithos</i>

It may be remarked, as regards the 1st stone of the 1st row, that in the time of Jos the stone *sardónuz* could be signified also by the more general term *sardion*; and, as regards the 1st stone of the 2d row, that *ánthraz* and *carbo* being respectively Gr and Lat for "glowing coal," *ánthraz* and *carbunculus*, diminutive of *carbo*, were used as synonyms for certain red stones.

From the inconsistencies of the above table of possible equivalents it may be inferred that either (1) essentially different tr<sup>s</sup> were given in several cases for the same Heb word, or (2) the Heb texts used in the preparation of the LXX and Vulg VSS were, in respect of the precious stones, different from each other and from that used in the preparation of EV, or (3) the breastplate differed at different epochs, or (4) one or other, or both, of the descriptions by Jos are incorrect. Conceivably differences may have arisen in all the above-mentioned ways.

(1) *Inconsistency of LXX translators.*—That the LXX translators were uncertain as to the correct tr of the Heb names used for the precious stones into the Gr names used in their time, and that they tr<sup>d</sup> the Heb name of a stone in more than one way may be shown as follows. In the Heb text corresponding to EV the word *shóham*, designating the 2d stone of the 4th row of the breastplate, occurs also in several verses where there is no mention of other stones, and where there is thus no risk of accidental interchange, such as may easily occur when technical terms, more esp. if unintelligible to the transcriber, are near to one another in the text. Now, for our VSS *shóham* has been systematically tr<sup>d</sup> "onyx," and for the Vulg the Heb word having the same position in the text has been systematically tr<sup>d</sup> by a Lat synonym of onyx, namely, *lapis onychinus* (except in Job 28 16, where *lapis sardonichus* is the rendering). Hence it is probable that the word in these particular verses was *shóham* in the Heb original of the Vulg, and therefore also of the Heb original of the LXX. Yet in the LXX the Heb word is tr<sup>d</sup> *sóom* (1 Ch 29 2, indicating that the translator, not knowing the Gr word for *shóham*, gave merely its Gr transliteration), as well as *smaragdus* (Ex 28 9; 35 27; 39 6 or LXX 36 13), *prásinos* (Gen 2 12), *sardion* (Ex 25 7; 35 9 or LXX 35 8), *ónux* (Job 28 16).

These differences suggest that there were different LXX translators, even for different chapters of the same book, and that little care was taken by them to be consistent with one another in the tr of technical terms.

(2) *Differences of Hebrew texts.*—That the Heb texts used for the LXX, Vulg and EV were not identical in all the verses in which there is mention of precious stones is esp. clear from an analysis of the respective descriptions of the ornaments of the king of Tyre (Ezk 28 13). In the LXX 12 stones are mentioned; as already stated, they have precisely the same names and are mentioned in precisely the same order as the stones of the breastplate described in that version, the only difference being that gold and silver are inserted in the middle of the list. On the other hand, in Vulg and EV descriptions of the ornaments, only 9 of the 12 stones of the breastplate are mentioned; they are not in the same order as the corresponding stones in the breastplate as described in those VSS, silver is not mentioned at all, while gold is placed, not in the middle, but at the end of the list. Further, the order of mention of the stones in EV differs from that of mention in Vulg.

(3) *Changes in the breastplate.*—That the breastplate in use in the time of the LXX translators (about 280 BC) may have been different from the one described in the Book of Ex is manifest if we have regard to the history of the Jewish nation; for Jerus was captured by Shishak, king of Egypt, about 973 BC, by Nebuchadnezzar, king of Babylon, about 586 BC, and by Ptolemy Soter, king of Egypt, about 320 BC. The original breastplate may have been part of the spoil on one or other of these occasions, and have then disappeared forever.

Again, between the times of the LXX translators and Jos, Jerus was more than once in the hands of its enemies; in 198 BC the city was captured by Antiochus the Great; in 170 BC it was stormed, and its temple plundered, by Antiochus Epiphanes; in 54 BC the temple was desecrated by Crassus. The breastplate familiar to Jos (for he was long a priest in the temple of Jerus) may thus not have been identical with that in use when the LXX version was made.

And if the signification of the Heb names of the stones had not been carefully passed down from one

generation to another while the breastplate was no longer in existence (for instance, during the Bab captivity), or if stones like those of the original breastplate were not available when a new breastplate was being made, there would inevitably be differences in the breastplate at different times.

The probability of this hypothesis of one or more replacements of the breastplate is still further increased if we have regard to the large stones that were set in gold buttons and fastened to the shoulder-pieces of the ephod, the vestment to which the breastplate itself was attached (Ex 28 9; 39 6 or LXX 36 13). According to the LXX, the material was *smaragdōs* (and therefore green); according to Jos it was *sardonux* (and therefore red with a layer of white). Though the LXX translators may never have had opportunities of looking closely at the stones, they might be expected to know the color of the material; Jos must have seen them often. But the complete difference of colors of *smaragdōs* and *sardonux* suggests that the difference of the names is due, not to a LXX mistranslation of the Heb name *shōham*, but to an actual difference of the material; it may have been *smaragdōs* (and green) at the time when the LXX tr was made, and yet *sardonux* (and red with a layer of white) in the time of Jos.

(4) *Descriptions given by Jos.*—That in respect of the breastplate it is unsafe to collate the Heb texts of the various VSS with that of Jos may be demonstrated as follows. The 2d stone of the 2d row, termed *šappīr* in our Heb text, is termed *sappheiros* in the LXX and *sapphirus* in the Vulg. Wherever else *šappīr* occurs in our Heb text, *sappheiros* occurs in the corresponding place in the LXX and *sapphirus* in the Vulg; it may thus be inferred that in respect of the word *šappīr* our Heb text and the Heb texts used for the LXX and Vulg VSS were in complete accord with one another. Also, it is certain that the Lat word *sapphirus* was derived from the Gr word *sappheiros*, and that either the latter had its origin in the Heb word *šappīr* or that both words had the same source. There is no reason to think that from the time of the LXX translators to that of St. Jerome the word *sappheiros* was ever used to signify any other than one kind of stone or that the kind was ever called *iaspis*. But in both the descriptions given by Jos the middle stone of the 2d row is given as *iaspis*, not as *sappheiros*, which he makes the last stone of the row. Hence, for the middle stone of the 2d row, the Heb texts were concordant in giving the name *šappīr*, but they fundamentally differed from that of Jos whose two descriptions agree in giving the name *iaspis*; it is not a difference of mere nomenclature or tr, but of the kind of stone set in a definite part of the breastplate. This being the case, collation of the Heb, LXX and Vulg descriptions of the breastplate with those given by Jos cannot be relied on to give a true Gr or a true Lat equivalent for the Heb name of any of the stones.

It may be added that the two descriptions given by Jos differ from each other only as regards the order of the stones in the last two rows; in the 3d row, the order is precisely reversed; in the 4th row the order is *chrusolīthos*, *onuchion*, *bērullion* for *Ant*, and *onuchion*, *bērullion*, *chrusolīthos* for *BJ*. *Ant* was written at greater leisure than *BJ*, and was not completed till 18 years later; Jos had thus more time for the consultation of old MSS. Speaking generally, it is more accurate than his earlier treatise as regards the history of those times of which he had no direct knowledge; its description of the breastplate is more precise as regards the arrangement of the stones, and is therefore the one to which the greater weight must be given. It differs from the LXX only through the interchange of the 2d

and 3d stones in the 2d, 3d and 4th rows; and possibly Jos gave the order from his memory either of the LXX or of the actual breastplate.

The only difference between the descriptions given in LXX and Vulg is that the last two stones, namely *bērullion* (*beryllus*) and *onuchion* (*onychinus*), are interchanged.

**8. Vulgate and LXX** As already pointed out, the Heb texts of the LXX and EV must have differed completely as regards the descriptions of the ornaments of the king of Tyre; it is thus not at all certain that they were in complete accord as regards the descriptions of the breastplate. In fact, it is generally accepted that the Heb word *yāshephēh* and the Gr word *iaspis* are virtually identical, and that they were used to signify the same kind of stone. Hence it follows that the Heb text of EV is not identical with the Heb texts of the LXX and Vulg VSS in respect of the stones

in the 2d and 4th rows; if our Heb text is correct as regards *yāshephēh*, that stone was the last stone in the last row; if the Heb texts of the LXX and Vulg VSS were correct, *yāshephēh*, which had for its Gr equivalent *iaspis*, must have been the last stone in the 2d row; further, *onuchion* (LXX) and *beryllus* (Vulg) must be equivalent, not to *yāshephēh*, but to some other stones of the breastplate.

Taking these matters into consideration, the following have considerable claims to be regarded as equivalents:

	Heb	Gr
<b>10. Equivalence of Hebrew and Greek Names</b>	'ādhem pītdhāh bāreketh nāphekh šappīr lēshem sh'bhō 'ahlāmāh yāshephēh	<i>sardion</i> <i>topazion</i> <i>smaragdōs</i> <i>anthrax</i> <i>sappheiros</i> <i>ligurion</i> <i>achatēs</i> <i>amethystos</i> <i>iaspis</i>

The remaining three stones, *tarshish*, *shōham* and *yahōlōm*, are thus equivalent to *chrusolīthos*, *onuchion* and *bērullion*, but it is uncertain which Gr name corresponds to any of those Heb names.

For the interpretation of the Gr names of stones mentioned in the LXX (and thus of the Heb names in the original text), the work of Theophrastus, a contemporary of the LXX translators, is very useful. That author mentions, besides *krīstallos* and *margārītēs* which occur elsewhere than in the description of the breastplate, nine of the LXX names of the breastplate stones, namely:

**11. Interpretation of Greek Names** *achatēs*, *amethystos* (as *amēthuson*), *anthrax*, *iaspis*, *ligurion* (as *lugkārion*), *onuchion*, *sappheiros*, *sardion*, *smaragdōs*. The three stones mentioned in the LXX but not by Theophrastus are *bērullion*, *chrusolīthos* and *topazion*. As he mentions only four stones that are not referred to in LXX, namely *chrusōkolla*, *hualoeidēs*, *kuanós* and *ōmphax*, it follows that the LXX translators at Alexandria introduced every important name that was then in use at Athens for a precious stone.

In the following alphabetical list references are given to all the verses in which each name of a precious stone occurs, and for each use of a tr<sup>d</sup> name the corresponding word in the original text.

*Achatēs* (ἀχάτης, *achātēs*): probably LXX tr of *sh'bhō* (Ex 28 19; 39 12). It is not mentioned in Apoc or the NT.

**12. Names with Biblical References** Adamant (see also special art.): in Ezk 3 9; Zec 7 12, EV tr of Heb *shāmīr*.

Agate: in Ex 28 19; 39 12, EV tr of Heb *sh'bhō*; in Isa 54 12; Ezk 27 16, AV tr of Heb *kadhkōdh*.

'Ahlāmāh, אֶהְלָמָה: in Ex 28 19; 39 12: 3d stone, 3d row, of the breastplate. LXX translates *amethystos*; Vulg translates *amethystus*; EV "amethyst."

The LXX rendering *amethystos* is generally accepted as correct, but the late Professor N. S. Maskelyne, F. R. S., formerly (1857-80) Keeper of Minerals in the British Museum, gave reasons for regarding the 'ahlāmāh of breastplate times as possibly an onyx in which white bands alternated with waxy-yellow to reddish-yellow bands.

Amber: in Ezk 1 4.27; 8 2, AV, ERV and



ARV<sup>m</sup> tr of Heb *hashmal*; in Ex 28 19, RV<sup>m</sup> tr of Heb *leshem*.

*Amethystos* (ἀμέθυστος, *amethystos*): in Rev 21 20: the 12th foundation of the New Jerusalem; Vulg translates *amethystus*; EV "amethyst." Four varieties of *amethystus* were recognized by Pliny as precious; all of them were transparent, and of purple tint or of tints derived from purple. According to LXX, *amethystos* was the 3d stone, 3d row, of the breastplate, and the stone occupying this position is given in our Heb text as *'ahlāmāh*. *Amethystos* is mentioned under the name *amethuson* by Theophrastus; he describes it as a transparent stone resembling wine in color and as used by the gem engravers of his day. *Amethystus* and *amethuson* were doubtless identical with the amethyst of the present day, a purple variety of quartz (silica). Beads and other ornaments of amethyst found in old Egypt tombs show that the stone was regarded as precious in very ancient times.

*Amethyst*: in Ex 28 19; 39 12, EV tr of Heb *'ahlāmāh*; in Rev 21 20, EV tr of Gr *amethystos*.

*Anthrax* (ἀνθραξ, *ánthrax*): in Tob 13 17; Eccles 32 5, EV translates "carbuncle." According to LXX, *ánthrax* was also a stone of the breastplate, 1st stone, 2d row, but there is uncertainty as to the Heb text of the LXX in respect of this word. The *ánthrax* of Theophrastus included different kinds of hard, red stone used by the gem engravers. It is the *carbunculus* of Pliny's time, and probably included the oriental ruby (corundum, alumina), the balas ruby (spinel, aluminate of magnesium), the almandine (a kind of garnet, aluminosilicate of iron) and pyrope (another kind of garnet, aluminosilicate of magnesium) of the present day.

*Bārekeṭh*, בָּרֵקֶת, in Ex 28 17; 39 10; Ezk 28 13: 3d stone, 1st row, of breastplate. LXX probably translates *smaragdus*, but there is uncertainty as to the Heb text of the LXX in respect of this word: EV translates "carbuncle"; RV<sup>m</sup> translates "emerald." The rendering *smaragdus* may be correct, but no emeralds of very early age have been found in Egypt. From the similarity of the words *bārekeṭh* and *bārak* ("lightning"), it has been suggested that possibly the breastplate stone was not green but of bluish-red color, in which case it may have been an almandine (garnet). EV has interchanged the names given by LXX to the 3d stone of the 1st row (*smaragdus*, "emerald") and the 1st stone of the 2d row (*ánthrax*, "carbuncle").

*Bdellium* (see also special art.): in Gen 2 12; Nu 11 7, EV tr of Heb *b'dhōlah*.

*B'dhōlah*, בְּדִלְיָה: LXX translates *ánthrax* in Gen 2 12, and *krustallos* in Nu 11 7; Vulg and EV translate *bdellium*. Some commentators, rejecting both the LXX tr<sup>s</sup>, interpret the material to be pearl, others to be the gum of an Arabian tree.

*Bērullus* (βήρυλλος, *bērullus*): in Tob 13 17; Rev 21 20: the 8th foundation of the New Jerusalem. Vulg translates *beryllus*; EV translates "beryl." According to LXX, *bērullion* was a stone of the breastplate, the 2d stone, 4th row; owing to uncertainty as to their Heb text, there is doubt as to the Heb word tr<sup>d</sup> *bērullion*. *Bērullus* is not mentioned by Theophrastus, who may have regarded it as included in the *smaragdus* of his day.

In the time of Pliny 8 varieties were recognized; he says that *beryllus* was already thought by some to be "of the same nature as the *smaragdus*, or at least closely analogous. India produces them, and they are rarely to be found elsewhere. The lapidaries cut all beryls of a hexagonal form because the color which is deadened by a dull uniformity of surface is heightened by the reflections resulting from the angles. If they are cut in any other way, these stones have no brilliancy whatever. The most esteemed beryls are those which in color resemble the pure green of the sea. Some are of opinion that beryls are naturally angular."

This description suggests the identity of the sea-green *beryllus* of Pliny's time with the sea-green beryl (aluminosilicate of beryllium) of the present day.

*Beryl*: in Ex 28 20; 39 13; Cant 5 14; Ezk 1 16; 10 9; 28 13; Dnl 10 6, EV tr of Heb *tarshish*; in Gen 2 12; Ex 25 7 m; 28 9,20; 35 27 m; 1 Ch 29 2 m; Job 28 16 m, RV<sup>m</sup> tr of Heb *shōham*; in Tob 13 17; Rev 21 20, EV tr of Gr *berullos*.

*Carbuncle*: in Ex 28 17; 39 10; Ezk 28 13, EV tr of Heb *bārekeṭh*; in Ex 28 18 m; 39 11; Ezk 27 16; 28 13, RV<sup>m</sup> tr of Heb *nōphekkh*; in Isa 54 12, EV tr of Heb *'ekdāh*; Tob 13 17; Eccles 32 5, EV tr of Gr *ánthrax*.

*Chalcedony*: in Ex 28 20, RV<sup>m</sup> tr of Heb *tarshish*; in Rev 21 19, EV tr of Gr *chalkēdōn*.

*Chalkēdōn* (χαλκήδών, *chalkēdōn*): in Rev 21 19: the 3d foundation of the New Jerusalem. Vulg translates *calcedonius*; EV translates "chalcedony." Though the name Chalcedon (Lat form) occurs in Pliny, it is not as the name of a stone but as that of a free town then standing on the southern side of the Bosphorus, probably close to the site on which Scutari now stands. Chalcedon had once been noted for its copper mines; but the latter, when Pliny wrote, had been so far exhausted that they were no longer worked.

Pliny refers to a kind of *smaragdus* (a green stone) as having been found near Chalcedon, but adds that the stones were of very small size and value. They were "brittle, and of a color far from distinctly pronounced; they resembled in their tints the feathers that are seen in the tail of the peacock or on the neck of the pigeon. More or less brilliant, too, according to the angle at which they were viewed, they presented an appearance like that of veins and scales." In another place he refers to a stone from Chalcedon or Calchedon (another reading) as being an *iaspis* of turbid hue. It is possible that at Patmos or Ephesus, at one of which St. John was living when he wrote the Book of Rev, the word *chalkēdōn* was used to specify the particular kind of *smaragdus* or *iaspis* that had been found near the town of that name. It is uncertain what name would be given to such a stone in the present day, but the signification now attached to the name "chalcedony" (cryptocrystalline silica) cannot be traced farther back than the 15th cent.

*Chrusolīthos* (χρυσόλιθος, *chrusolīthos*): in Rev 21 20: the 7th foundation of the New Jerusalem. Vulg translates *chrysolithus*; AV translates "chrysolite"; RV translates "chrysolite." According to LXX *chrusolīthos* was one of the stones of the breastplate (1st stone, 4th row), but there is uncertainty as to the Heb text of the LXX in respect of this word; the name is not mentioned by Theophrastus. The *chrysolithus* of Pliny was a "transparent stone with a refulgence like that of gold." Those were most valued which "when placed by the side of gold, impart to it a sort of whitish hue, and so give it the appearance of silver."

It may perhaps have included the yellow sapphire (alumina), the yellow quartz (citrine, silica) and the yellow jargon (zircon, silicate of zirconium) of the present day. The term "chrysolite" is now applied to a different mineral, namely, to a yellow variety of olivine (silicate of magnesium and iron), a species that includes the green precious stone peridot as another of its varieties.

*Chrusoprasos* (χρυσόπρασος, *chrusoprasos*): in Rev 21 20: the 10th foundation of the New Jerusalem. Vulg and AV translate *chrysoprasus*; RV translates "chrysoprase." The *chrysoprasus* was regarded by some naturalists of the time of Pliny as a variety of *beryllus*. The 1st variety of *beryllus* and the most esteemed was, as stated above, of a pure sea-green color; the 2d was paler, and approached a golden tint; the 3d, allied to the 2d in brilliancy but more pallid, was the *chrysoprasus*. The latter was thought by other naturalists to belong to an independent genus of stone. In another place Pliny describes the color

as like that of the leek, but as varying in tint between the *topazion* of his day (our peridot) and gold. The stone may have been a yellowish-green plasma (*chalcledony*, crypto-crystalline silica) or, as suggested by King, pale chrysoberyl (aluminate of beryllium); it is not the chryso-prase of the present day, which is an apple-green chalcledony (colored by nickel).

**Chrysolite, chrysolite:** "chrysolite" in Ezk 28 13, AVm tr of Heb *tarshish*; Rev 21 20, RV tr of Gr *chrusolithos*; "chrysolite" in Rev 21 20, AV tr of Gr *chrusolithos*.

**Chryso-prase, chryso-prasus:** "chryso-prase" in Ezk 27 16, AVm tr of Heb *kadhkôdh*; Rev 21 20, RV tr of Gr *chrusoprasos*; "chryso-prasus" in Rev 21 20, AV tr of Gr *chrusoprasos*.

**Coral, red coral** (see special art.): "coral" in Job 28 18; Ezk 27 16, EV tr of Heb *râ'môth*; Lam 4 7, RVm tr of Heb *p'nînim*; "red coral" in Job 28 18, RVm tr of Heb *p'nînim*.

**Crystal** (see special art.): in Job 28 17, AV tr of Heb *z'chûkhûth*; Ezk 1 22, AV tr of Heb *kerah*; in Job 28 18, RV tr of Heb *gâbhîsh*; in Rev 4 6; 22 1, EV tr of Gr *krustallos*; in Rev 21 11, EV tr of Gr *krustallizô* ("to shine like crystal").

**Diamond:** in Jer 17 1, EV tr of Heb *shâmûr*; in Ex 28 18; 39 11; Ezk 28 13, EV tr of Heb *yahôm*.

**Ekdâh, קָרָה:** in Isa 54 12: LXX translates *krustallos*; Vulg periphrases as *lapides sculpti* ("engraved stones"); EV translates "carbuncles." From the similarity to קָרָה, *kâdhah*, "to burn," it is interpreted as meaning fiery or sparkling, whence comes the rendering "carbuncles."

**Electrum** (see special art.): Ezk 1 4, RVm tr of Heb *hashmal*, "amber."

**Emerald:** in Ex 28 18; 39 11; Ezk 27 16; 28 13, EV tr of Heb *nôphekh*; in Ex 28 17; 39 10, RVm tr of Heb *bâreket*; in Tob 13 16; Jth 10 21; Ecclus 32 6; Rev 21 19, EV tr of Gr *smaragdus*; in Rev 21 19, EV tr of Gr adj. *smaragdinos*.

**Gâbhîsh, גַּבְיִשׁ:** in Job 28 18: LXX transliterates *gabîs*; AV translates "pearls"; RV translates "crystal." From the similarity to גַּבְיִשׁ, *gâbhash*, "ice," the rendering "crystal" is suggested.

**Hashmal, הַשְּׂמַל:** in Ezk 1 4.27; 8 2: LXX translates *elektron*; Vulg and RVm translate *electrum*; AV, ERV and ARVm translate "amber"; ARV translates "glowing metal." The *elektron* of the time of the LXX and Theophrastus was the amber of the present day; in the time of Pliny amber was an object of luxury ranked next to crystal, and the term *electrum* was then applied, not only to amber, but also to a metallic alloy of gold and silver.

**Huâkinthos (ὕακινθος, huâkinthos):** in Rev 9 17; 21 20: the 11th foundation of the New Jerusalem. Vulg translates *hyacinthus*; AV translates "jacinth"; RV translates "jacinth" (Rev 21 20) and "hyacinth" (Rev 9 17); RVm translates "sapphire" (Rev 21 20). Pliny describes the *hyacinthus* as being very different from *amethystus*, "though partaking of a color that closely borders upon it" and as being of a more diluted violet. It may have been the pale blue sapphire (alumina) of the present day; the modern hyacinth, or jacinth, is a quite different stone, a brownish to reddish zircon (silicate of zirconium).

**Hyacinth, jacinth** (see also special art. on HYACINTH): "hyacinth" in Rev 9 17, RV tr of Gr *huâkinthos*; "jacinth" in Ex 28 19; 39 12, RV tr of Heb *leshem*; in Rev 9 17; 21 20, AV tr of Gr *huâkinthos*.

**Iaspis (ἰάσπις iaspis):** in Rev 4 3; 21 11.18 f: the 1st foundation of the New Jerusalem. Vulg

translates *jaspis*; EV translates "jasper." According to LXX *iaspis* was the 3d stone, 2d row, of the breastplate, but there is uncertainty as to the Heb text of the LXX in respect of this word; LXX translates also *kadhkôdh* as *iaspis* (Isa 54 12). Pliny describes *iaspis* as being generally green and often transparent; he recognizes as many as 14 varieties.

He adds that "many countries produce this stone: that of India is like *smaragdus* in color; that of Cyprus is hard and of a full sea-green; and that of Persia is sky-blue. Similar to the last is the Caspian *iaspis*. On the banks of the river Thermodon the *iaspis* is of an azure color; in Phrygia it is purple; and in Cappadocia of an azure-purple, somber and not refugent. The best kind is that which has a shade of purple, the next best being the rose-colored, and the next the stone with the green color of the *smaragdus*," etc.

The term "jasper" is now restricted to opaque stones; the green transparent kind of *iaspis* may have been identical with the green chalcledony (crypto-crystalline silica) called plasma at the present day.

**Jasper:** in Ex 28 20; 39 13; Ezk 28 13, EV tr of Heb *yâsh'phêh*; in Rev 4 3; 21 11.18.19, EV tr of Gr *iaspis*.

**Kadhkôdh, קָדְדָה:** in Isa 54 12; Ezk 27 16: LXX translates *iaspis* (Isa 54 12) and transliterates *chorchor* (Ezk 27 16); Vulg translates *jaspis* (Isa 54 12) and transliterates *chodchod* (Ezk 27 16); AV translates "agate"; AVm translates "chryso-prase" (Ezk 27 16); RV translates "ruby." There is little to indicate the probable meaning of the word.

**Kerâh, קָרָה:** in Ezk 1 22: LXX translates *krustallos*; Vulg translates *crystalum*; EV translates "crystal"; RVm translates "ice." The translations are suggested by the similarity to the Heb *kerâh, קָרָה, "ice."*

**Krustallos (κρυσταλλος, krústallos):** in Rev 4 6; 22 1: Vulg translates *crystalum*; EV translates "crystal." The *crystalum* of Pliny was the rock-crystal (clear quartz) of the present day. Among the localities cited for *crystalum* by Pliny are "the crags of the Alps, so difficult of access that it is usually found necessary to be suspended by ropes in order to extract it."

**Lapis lazuli:** in Rev 21 19, RVm tr of Gr *sappheiros*.

**Leshem, לֶשֶׁם:** in Ex 28 19; 39 12: 1st stone, 3d row, of the breastplate. LXX probably translates *ligurion*, but there is uncertainty as to their Heb text; Vulg probably translates *ligurius*; AV translates "ligure"; RV translates "jacinth"; RVm translates "amber."

The *ligurion* of LXX is probably identical with the *lugkurion* of Theophrastus; this was a yellow to yellowish-red stone used by seal engravers, and was transparent and difficult to polish. The yellow *ligurion* may be the yellow jargon of the present day (zircon, silicate of zirconium), a stone much used by the ancient Gr and Rom engravers; but as the jargon has not been found among ancient Egypt work, it has been suggested that the *ligurion* of the breastplate may have been a yellow quartz (citrine) or agate. The yellowish-red *ligurion* may have been one of the stones to which the name "jacinth" (also a zircon) is now applied. Professor Maskelyne, rejecting the LXX tr, suggests that the *leshem* was identical with the *neshem* of the Egyptians, namely the green feldspar now called amazon stone; as an alternative rendering to this he suggests yellow jasper. The tr "amber" (RVm) is not likely to be correct, for that material would have been too soft for use as a stone of the breastplate; its properties do not accord with those assigned by Theophrastus to the *lugkurion*.

**Ligure:** in Ex 38 19; 39 12, AV tr of Heb *leshem*.

**Ligurion (Λιγύριον, ligúrión):** in LXX Ex 28 19; 39 12, LXX tr of Heb *leshem*: 1st stone, 3d row, of breastplate.

**Margarites (μαργαρίτης, margarítēs):** in Mt 7 6;

13 45.46; 1 Tim 2 9; Rev 18 12.16; 21 21: Vulg translates *margarita*; EV translates "pearl." The *margaritēs* is mentioned by Theophrastus as being one of the precious stones, but not pellucid, as produced in a kind of oyster and in the *pinna*, and as brought from the Indies and the shores of certain islands in the Red Sea. Hence it was identical with the pearl of the present day.

*Nōphekkh*, נֹפֶחַךְ: in Ex 28 18; 39 11; Ezk 27 16; 28 13: 1st stone, 2d row, of the breastplate. There is uncertainty as to the Heb text used by the LXX, but probably *nōphekkh* is translated *anthrax* (except in Ezk 27 16, where the text differs); Vulg probably translates *carbunculus*; EV translates "emerald"; RVM translates "carbuncle." EV interchanges the names given by the LXX to the 3d stone, 1st row (*smaragdus*, "emerald") and the 1st stone, 2d row (*anthrax*, "carbuncle"). Professor Maskelyne suggests that the *nōphekkh* of the breastplate may have been the *mophak* or *mafka* of the Egyp hieroglyphics, the turquoise of the present day.

*ʾōdhem*, אֹדְהֵם: in Ex 28 17; 39 10; Ezk 28 13: 1st stone, 1st row, of the breastplate. LXX probably translates *sardion*; Vulg probably translates *sardius*; EV translates "sardius"; EVM translates "ruby." The Heb word is related to *ʾādham*, אֲדָמָה, "to be red," and signifies a reddish stone; it may have been sard (a name given not only to red, but also to pale reddish-yellow or brown, translucent chalcidony), but was more probably carnelian, a red stone closely allied to sard, and much used by the ancient Egyptians and Assyrians.

*Onuchion*, *onux* (ὀνύχιον, *onūchion*, ὄνυξ, *onux*): "onux," LXX tr of Heb *shōham* (Job 28 16); *onuchion*, perhaps LXX tr of *shōham* in the descriptions of the ornaments of the king of Tyre (Ezk 28 13) and the stones of the breastplate (being there made 3d stone, 4th row, in Ex 28 20; 39 13), but there is uncertainty as to the Heb text of the LXX; Vulg translates *onyx*, *lapis onychinus*, *lapis sardonichus*. The *onuchion* of Theophrastus was a hard, translucent stone used by the seal engravers; it consisted of white and dusky layers in alternation. The *onyx* of Rom times was an opaque stone of white and black layers, like the *onyx* of the present day.

*Onyx*: in Gen 2 12; Ex 25 7; 28 9.20; 35 9. 27; 39 6.13; 1 Ch 29 2; Job 28 16; Ezk 28 13, EV tr of Heb *shōham*.

*Pearl*: in Job 28 18, AV tr of Heb *gābhāsh*; in Job 28 18, RVM tr of Heb *pʾnānīm*; in Mt 7 6; 13 45f; 1 Tim 2 9; Rev 18 12.16; 21 20.21, EV tr of Gr *margaritēs*.

*Pʾnānīm*, פְּנִינִים: in Job 28 18; Prov 3 15; 8 11; 20 15; 31 10; Lam 4 7: LXX (from which Prov 20 15 is missing) paraphrases the word or had a different Heb text; Vulg translates *ebur antiquum* ("old ivory") in Lam 4 7, but elsewhere paraphrases the word or had a different Heb text; EV translates "rubies"; RVM translates "red coral," or "pearls," except for Lam 4 7, where the tr is "corals." The word is similar to an Arab. word meaning "branches" and may signify red coral, which has been highly esteemed since very ancient times; a description of *korāllion* is given by Theophrastus. Pliny says that in his day the reddest and most branched was most valued.

*Pīʾdhāh*, פִּידְהָה: in Ex 28 17; 39 10; Job 28 19; Ezk 28 13: 2d stone, 1st row, of the breastplate. LXX translates *topazion* in Job 28 19 and probably also in the other verses; Vulg translates *topazius*; EV translates "topaz." The *topazion* of ancient times appears to have been scarcely known before the Ptolemaic period, and Professor Maskelyne suggested that the Heb word may possibly be

allied to *bijada*, which in Pers and Arab. signifies "garnet."

*Ramoth*: in Job 28 18, AVm tr of Heb *rāʾmōth*. *Rāʾmōth*, רָאֲמוֹת: in Job 28 18; Ezk 27 16: LXX translates *metēōra* (Job 28 18) and *ramoth* (Ezk 27 16); Vulg paraphrases the passages; EV translates "coral"; AVm translates "ramoth" (only in Job 28 18). There is little to indicate the meaning of the Heb word.

*Ruby*: in Job 28 18; Prov 3 15; 8 11; 20 15; 31 10; Lam 4 7, EV tr of Heb *pʾnānīm*; in Isa 54 12; Ezk 27 16, RV tr of Heb *kadhkōdh*; in Ex 28 17; 39 10; Ezk 28 13, AVm tr of Heb *ʾōdhem*.

*Sappheiros* (σάπφειρος, *sappheiros*): in Tob 13 16; Rev 21 19: the 2d foundation of the New Jerusalem. Vulg translates *sapphirus*; EV translates "sapphire"; RVM translates "lapis lazuli" (but only in Rev 21 19). According to LXX, *sappheiros* was the 2d stone, 3d row, of the breastplate, but there is uncertainty as to the Heb text. Pliny describes *sapphirus* as "refulgent with spots like gold. It is also of an azure color, though sometimes, but rarely, it is purple; the best kind being that which comes from Media. In no case, however, is this stone transparent." These characteristics correspond to the lapis lazuli (sulphato-silicate of sodium and aluminium), not to the sapphire (alumina) of the present day.

*Sappīr*, סַפִּיר: in Ex 24 10; 28 18; 39 11; Job 28 6.16; Cant 5 14; Isa 54 11; Lam 4 7; Ezk 1 26; 10 1; 28 13: 2d stone, 2d row, of the breastplate. LXX translates *sappheiros*; Vulg translates *sapphirus* and (Ex 24 10) *lapis sapphirinus*; EV translates "sapphire." The Heb word is universally accepted as equivalent to the Gr *sappheiros*; that name was used, not for the stone now known as sapphire, but for that now known as lapis lazuli, a substance which was regarded by the ancient Egyptians as a precious stone.

*Sardine* (stone), *sardius*: "sardine" (stone) in Rev 4 3, AV tr of Gr *sárdinon*, an error of text for *sardion*; "sardius" in Rev 4 3, RV tr of Gr *sardion*; in Rev 21 20, EV tr of Gr *sardion*; in Ex 28 17; 39 10; Ezk 28 13, EV tr of Heb *ʾōdhem*.

*Sardion* (σάρδιον, *sárdion*): in Rev 4 3; 21 20: the 6th foundation of the New Jerusalem. According to LXX, *sardion* was the 1st stone, 1st row, of the breastplate. Vulg translates *sardius*; AV translates "sardine" (stone) (Rev 4 3) and "sardius" (Rev 21 20); RV translates "sardius." The *sarda* of Pliny's time was much used by the seal engravers. There were three Indian varieties, all of them transparent, one of them red in color; there was then no precious stone in more common use; those of honey-color were less valued. It probably included both the sard and the carnelian of the present day (crypto-crystalline silica).

*Sapphire*: in Ex 24 10; 28 18; 39 11; Job 28 6.16; Cant 5 14; Isa 54 11; Lam 4 7; Ezk 1 26; 10 1; 28 13, EV tr of Heb *sappīr*; in Tob 13 16; Rev 21 19, EV tr of Gr *sappheiros*; in Rev 21 20, RVM tr of Gr *huakinthos*.

*Sardonux* (σαρδόνυξ, *sardónux*): in Rev 21 20: the 5th foundation of the New Jerusalem. Vulg and EV translate *sardonux*. According to Pliny, the name *sardonux* was at first given to an Indian (red) *sarda* with a layer of white in it, both being transparent.

Pliny says that later three colors were considered essential, but that they might be repeated indefinitely. The Arabian *sardonux* was "characterized by several different colors, black or azure for the base and vermilion surrounded with a line of rich white for the upper part, not without a certain glimpse of purple as the white passes into the red."

The *sardonux* of St. John's time is included in the *sardonux* of the present day.

**Sardonyx:** in Rev 21 20, EV tr of Gr *sardonuz*; Ex 28 18; 39 11, RVm tr of Heb *yahālōm*.

**Shāmīr, שַׁמִּיר:** in Jer 17 1; Ezk 3 9; Zec 7 12; LXX omits Jer 17 1, and in the other two verses either periphrases the word or had a different text; Vulg translates (*unguis adamantinus* in Jer 17 1, and *adamas* in the other two verses; EV translates "diamond" (Jer 17 1) and "adamant" (Ezk 3 9; Zec 7 12). *Shāmīr* was a hard material used for engraving precious stones; in the days of Jeremiah, Ezekiel and Zechariah, splinters of both diamond and corundum (white sapphire or adamant stone) were probably available for the purpose. Both diamond and adamant are Eng. modifications of the Lat *adamas*; the form "diamond" has been restricted for some centuries to the more precious of the above stones.

**Sh'bhō, שְׁבֹר:** in Ex 28 19; 39 12: the 2d stone, 3d row, of the breastplate. Both LXX and Vulg probably translate *achatēs*, but their Heb texts are uncertain; EV translates "agate." The name *achatēs* was given in ancient times to certain stones having banded structures, the agates of the present day. In the time of Theophrastus *achatēs* was sold at a great price, but by the time of Pliny had ceased to be a precious stone. Professor Maskelyne suggests that the *sh'bhō* of the breastplate may have signified the "stone of Sheba" or "Seba," a district in Southern Arabia, and have been the Arabian onyx.

**Shōham, שְׁהָם:** in Gen 2 12; Ex 25 7; 28 9. 20; 35 9.27; 39 6.13; 1 Ch 29 2; Job 28 16; Ezk 28 13: the 2d stone, 4th row, of the breastplate. LXX translates *prāsinos*, i.e. "leek-green stone" (Gen 2 12), *sardion* (Ex 25 7; 35 9), *smaragdus* (Ex 28 9; 35 27), *bērullion*, probably through interchange of words in the Heb text (Ex 28 20; 39 13), *soom* (1 Ch 29 2), *onuz* (Job 28 16) and perhaps *onuchion* (Ezk 28 13); Vulg translates *onyx* (Ezk 28 13), *lapis sardonichus* (Job 28 16) and *lapis onychinus* elsewhere; EV translates "onyx"; RVm translates "beryl" (except in Ezk 28 13). Professor Maskelyne and Professor Sayce, accepting green as the color of *shōham*, have expressed the opinion that the stone known by that name in very early times was the stone called 'siamu by the Assyrians, and therefore the green turquoise; Professor Maskelyne gives "amazon stone" as an alternative rendering of the word. *Bērullion* is given by LXX as the 2d stone, *onuchion* as the 3d stone, of the 4th row; *sardion* as the 1st stone, *smaragdus* as the 3d stone, of the 1st row; but their Heb text is uncertain.

**Smaragdinos, smaragdus (σμαράγδινος, smaragdinos):** in Rev 4 3: Vulg translates *smaragdinus*; EV translates "emerald." *Smaragdus (σμαραγδος, smaragdus)* in Tob 13 16; Jth 10 21; Ecclus 32 5; Rev 21 19: Vulg translates *smaragdus*; EV translates "emerald." According to LXX, *smaragdus* was the 3d stone, 1st row, of the breastplate, but their Heb text is uncertain. The *smaragdus* of Theophrastus was a small, scarce, presumably green, stone used by the gem engravers. In Pliny's time the genus *smaragdus* comprised no fewer than 12 kinds; one of them was the emerald of the present day, and probably the *smaragdus* of Theophrastus.

**Tarshish, תַּרְשִׁישׁ:** in Ex 28 20; 39 13; Cant 5 14; Ezk 1 16; 10 9; 28 13; Dnl 10 6: the 1st stone, 4th row, of the breastplate. LXX translates *tharsis* (Cant 5 14; Ezk 1 16; Dnl 10 6), *anthrax* (Ezk 10 9); in the remaining verses there is uncertainty as to the order of the Heb words in the several texts. The most likely LXX equivalent of *tarshish* is either *chrusolithos* or *bērullion*; Vulg

translates *hyacinthus* (Cant 5 14), *mare* ("sea") (Ezk 1 16), *chrusolithus* (Ezk 10 9; Dnl 10 6). LXX gives *anthrax* as the 1st stone, 2d row, *chrusolithos* as the 1st stone, 4th row, *bērullion* as the 2d stone, 4th row, of the breastplate; EV translates "beryl"; AVm translates "chrysolite" (in Ezk 28 13 only); RVm translates "chalcidony" (Ex 28 20; 39 13), "topaz" (Cant 5 14) and "stone of Tarshish" (Ezk 10 9). Professor Maskelyne suggests that the stone may have been citrine (quartz), if yellow as suggested by *chrusolithos*, and green jasper, if green as suggested by *bērullion*.

**Topaz:** in Ex 28 17; 39 10; Job 28 19; Ezk 28 13, EV tr of Heb *pit'dhāh*; in Rev 21 20, EV tr of Gr *topazion*; in Cant 5 14, RVm tr of Heb *tarshish*.

**Topazion (τοπάσιον, topázion):** in Rev 21 20: the 9th foundation of the New Jerusalem. According to LXX *topazion* was the 2d stone, 1st row, of the breastplate. Vulg translates *topazius*; EV translates "topaz."

The *topazion* of Pliny's time was "held in very high estimation for its green tints; when it was first discovered it was preferred to every other kind of precious stone." It was said to be brought from an island in the Red Sea, off the coast of Arabia. It was the only stone of high value that yielded to the action of the file. *Topazion* is not mentioned by Theophrastus. Pliny's account corresponds to the peridot of the present day (silicate of magnesium and iron), not to our topaz (fluosilicate of aluminium).

**Yahālōm, יְהָלֹם:** in Ex 28 18; 39 11; Ezk 28 13: the 3d stone, 2d row, of the breastplate. Owing to the uncertainty as to the order of the words in the Heb text of the LXX, there is uncertainty as to the Gr equivalent of *yahālōm*; probably it is one of the words *chrusolithos*, *bērullion*, *onuchion*, given by the LXX as the names of the stones of the 4th row. EV translates "diamond"; this is certainly wrong, for the stone had a name engraved on it and the method of engraving a diamond was not invented till 2,000 or 3,000 years after the breastplate was made; nor were diamonds, if known at all, then known so large as to be comparable in respect of size, with the other stones of the breastplate. RVm translates "sardonyx" (in Ex only). Professor Maskelyne suggests that the Heb *yahālōm* and the Gr *hualos* may be kindred words and that *yahālōm* may have been a bluish glass (considered valuable in very early times), or blue chalcidony, or perhaps even beryl.

**Yāsh'phēh, יָאֶשֶׁפֶה:** in Ex 28 20; 39 13; Ezk 28 13: the 3d stone, 4th row, of the breastplate. LXX probably translates *iaspis*, though *iaspis* is placed by LXX as the 3d stone, 2d row; Vulg probably translates *jaspis*; EV translates "jasper." The equivalence of the Heb *yāsh'phēh* and the Gr *iaspis* is generally accepted.

**Z'khūkhūth, זְכוּכְחִית:** in Job 28 17: LXX translates *hualos*, a name given at first to any transparent stone, but in later times only to glass; Vulg translates *vitrum*; AV translates "crystal"; RV translates "glass." *Z'khūkhūth* is related to a Heb word meaning "to be pure," whence the renderings crystal and glass. LAZARUS FLETCHER

**STONING, stōn'ing.** See PUNISHMENTS.

**STOOL, stōol (בִּגְדִים, 'obhnayim):** It is not clear what the character and purpose of this stool were (LXX has no reference to it). It seems to have been a chair of a peculiar sort upon which a woman reclined in parturition (Ex 1 16). The Heb word is in the dual number and primarily means "two stones." The only other place where it occurs is Jer 18 3, where it is rendered "wheels" (LXX ἐπι τῶν κλῶων, *epi tōn klōōn*, "on the stones"). In 2 K 4 10, the word tr<sup>d</sup> in AV as "stool" (בִּגְדִים,

*kissē*) is in RV more correctly tr<sup>d</sup> "seat." See also BIRTH-STOOL; SEAT. JESSE L. COTTON

**STORAX**, stō'raks. See POPLAR; STACTE.

**STORE-CITIES**, stōr'cit-iz (מִשְׁכָּנֹת, *mišk'nōth*): RV Ex 1 11 (of PITHOM and RAAMESSES [q.v.]) for AV "treasure cities" (cf 1 K 9 19; 2 Ch 8 4.6; 16 4, etc). Depots of provisions and magazines of arms.

**STOREHOUSES**, stōr'houz-iz, -ez: The following chief changes in the use of this word (representing various Heb words) in RV to be noted are: In Dt 28 8, RV has "barns" ('*āsāmīm*); in 1 Ch 27 25, "treasures" ('*ōṣārōth*); in Neh 12 25, for "thresholds" has "storehouses" ('*āsuppīm*), so, for "Asuppim" in 1 Ch 26 15.17 ("house of Asuppim," "toward Asuppim") has "store-house"; in Lk 12 24, for "storehouse" has "store-chamber" (*tamēion*). In other passages AV "storehouse" is retained (Gen 41 56; 2 Ch 32 28, *mišk'nōth*; Ps 33 7, '*ōṣārōth*; Jer 50 26, *ma'ābhūšim*).

**STORIES**, stō'rīz: For AV "stories" (*ma'ālōth*) in Am 9 6, RV reads "chambers" (in heavens); in Gen 6 16 (ark); Ezk 42 3.6 (temple), the word is supplied. RV in the latter verse reads in the text "the third story" (m as in AV). In 1 K 6 5.10, RV has "stories" (*yāṣi'a*, *yāṣi'a*; see TEMPLĒ), and in Ezk 41 6 supplies "stories."

**STORK**, stōrk (הַסִּידָה, *hāsīdhāh*; variously rendered in LXX: Lev 11 19, *ἐροδιός*, *erōdiós*; Dt 14 18, *πελεκάν*, *pelekán*; Job 39 13, *ἀσιδά*,

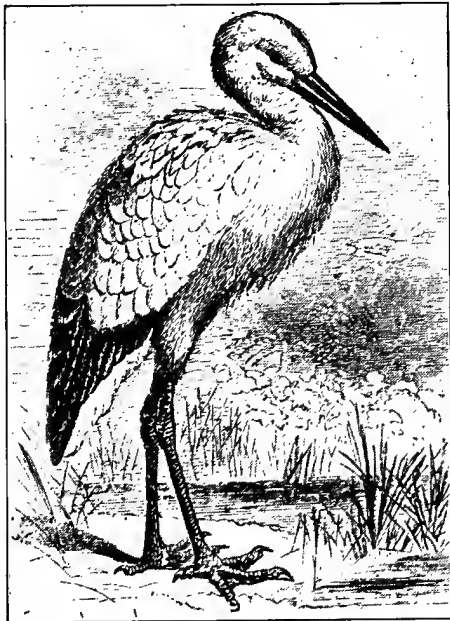

Stork.

*hasidā* [transliteration of Heb]; Zec 5 9, *ἔποψ*, *ēpops*; Lat *Ciconia alba*): A large wading bird of the family *Ardeidae*, related to crane, ibis, heron and bittern. The stork on wing is a bird of exquisite beauty. The primary, secondary and a few of the tertiary wing feathers are black, the remainder, also the head, neck, and back and under parts white, the bill and legs red. When a perching white bird suddenly unfolds these wonderful wings, having at times a sweep of 7 ft., and sails away, it makes

a very imposing picture. Zechariah in a vision saw a woman having the wings of a stork; Zec 5 9, "Then lifted I up mine eyes, and saw, and, behold, there came forth two women, and the wind was in their wings; now they had wings like the wings of a stork; and they lifted up the ephah between earth and heaven." These birds winter in Africa. In their spring migration many pairs pause in Pal, others cross the Mediterranean and spread over the housetops, ruins and suitable building-places of Europe as far north as Holland and England. Always and everywhere the bird has been more or less protected on account of its fidelity to a chosen location, its fearlessness of man and the tender love between mated pairs and for its young.

The stork first appears among the birds of abomination, and it is peculiar that the crane does not, for they are closely related. But the crane eats moles, mice, lizards and smaller animals it can capture, also frogs and fish. To this same diet the stork adds carrion and other offensive matter, and the laws of Moses, as a rule, are formulated with good reason. Yet at one time, storks must have been eaten, for Pliny quoted Cornelius Nepos, who died in the days of Augustus Caesar, as saying that "in his time storks were held for a better dish at board than cranes." Pliny adds: "Yet see, how in our age now, no man will touch a stork if it be set before him on the board, but everyone is ready to reach into the crane and no dish is more in request." He also wrote that it was a capital crime in Thessaly to kill storks, because of their work in slaying serpents. This may have been the beginning of the present laws protecting the bird, reinforced by the steady growth of respect and love for its tender, gentle disposition. The Heb word *hāsīdhāh*, from which the stork took its name, means "kindness."

There is a smaller stork having a black neck and back, that homes in Pal, but only in small numbers as compared with the white. These birds flock and live in forests around the borders of waste and desert places, and build in trees. The young of both species remain a long time in the nest and are tenderly cared for, so much so indeed that from their performances and love of building on housetops arose the popular tradition that the stork delivers newly born children to homes. The birds first appear in Lev 11 19 and Dt 14 18. Jeremiah noticed that the stork was migratory; see 8 7: "Yea, the stork in the heavens knoweth her appointed times; and the turtle-dove and the swallow and the crane observe the time of their coming; but my people know not the law of Jeh." The Psalmist referred to their nesting in the cedars of Lebanon, for in Pal these birds could not build on housetops, which were flat, devoid of chimneys and much used by the people as we use a veranda today; see Ps 104 17:

"Where the birds make their nests:  
As for the stork, the fir-trees are her house."

GENE STRATTON-PORTER

**STORY**, stō'ri. See COMMENTARY.

**STORY TELLING**. See GAMES, I, 4.

**STORY WRITER**, stō'ri-rīt-ēr: In the sense of chronicler or historian occurs in 1 Esd 2 17 (m "recorder") and 2 25.

**STOUT**, stout, **STOUTNESS**, stout'nes: In modern Eng. the word signifies strength, firmness, corpulence, etc, but in EV (Ps 76 5; Isa 10 12; 46 12; Dnl 7 20; Mal 3 13, with "stoutness" in Isa 9 9) it always means "bold" or "proud" and invariably in a bad sense; cf the Ger. *stolz*, with which "stout" is allied.

**STRAIGHT**, strāt, **STRAIGHTWAY**, strāt'wā: "Straight" and "strait" are two entirely different words that have no connection with each other in Eng., the former being derived from the Anglo-Saxon, while the latter has come back from the Lat through the Romance. At some point still farther back, however, the two words may have had some common original with the general meaning "to stretch." But in straight the stretched object is a cord from which all curvature is removed, while in strait a solid is thought of, which is drawn out and made narrow, used figuratively in Job 20 22; 36 16; Mt 7 13f; Phil 1 23. Before Eng. spelling had reached a relatively settled stage the spelling of the two words was interchanged occasionally, but in even Elizabethan times this could happen only through ignorance. In EV the forms are kept distinct with great care. "Straight," then, appears only in the sense "not crooked," in the OT most commonly for some form of **יָשָׁר**, *yāshar*, "be smooth" (2 Ch 32 30, etc). In the Apoc and NT the word is not very common, being used for *ὀρθός*, *orthós* (Bar 6 27; He 12 13); *εὐθύς*, *euthús* (Jth 13 20; Mk 1 3 and ||s), with the vbs. *ἀπορθῶ*, *anorthōō* (Lk 13 13), and *εὐθύνω*, *euthúnō* (Jn 1 23; He 12 12 RVm), "to make straight," and *εὐθύνω*, *euthudromēō*, "to make a straight course" (Acts 16 11; 21 1). For straightway in EV overwhelmingly the most common word is *εὐθύς*, *euthús*, or *εὐθέως*, *euthéōs*. AV varies the tr of this advb. by using either "straightway" or "immediately" without distinction, but RV (with a very few exceptions, e.g., Mt 24 29) has adhered to "straightway." The other occurrences in the Bible (1 S 9 13; 28 20, etc) represent no special word.

BURTON SCOTT EASTON

**STRAIGHT STREET**, strāt strēt. See DAMASCUS.

**STRAIN**, strān (**διυλίζω**, *diulizō*, "to strain off," "to filter"): Mt 23 24, "Ye blind guides, that strain out the gnat, and swallow the camel!" The imagery is that of a drinking-vessel full of liquid, from which tiny impurities are carefully removed while immense masses of other impure matter (Lev 11 4) are overlooked (cf Mt 7 3 f). The first ed of AV read the same as RV, but in the later edd a misprint converted "strain out" into "strain at," an error that has never been corrected.

**STRAIT**, strāt, **STRAITEN**, strāt'n, **STRAITLY**, strāt'li: The word "strait" and its compounds are used in EV in the literal sense of "narrow" (*צר*, 2 K 6 1; Isa 49 20; *مضيق*, Job 37 10; *أضال*, Ezk 42 6) and in the figurative sense of "strict" (*shābha'*, Ex 13 19; *ساقط*, Josh 6 1; *ضار*, "to be distressed," 2 S 24 14||; *يأقار*, Job 20 22; *مأقار*, Lam 1 3). In Apoc the vb. "straitened" occurs in Sus ver 22. In the NT we have *stenós* (Mt 7 13 f||, RV "narrow"; *πολύς*, "much"; so RV Mk 3 12; 5 43; *sunécho*, "to urge," "hold together," Lk 12 50; Phil 1 23). It occurs in its superlative form in Acts 26 5, "After the strictest [*akribéstatos*, "most exact," "scrupulous"] sect of our religion," i.e. "the most precise and rigorous in interpreting the Mosaic Law, and in observing the more minute precepts of the Law and of tradition" (Thayer, *Lex.*, s.v.; cf Acts 22 3). See also STRAIGHT, STRAIGHTWAY. M. O. EVANS

**STRAKES**, strāks: An older form for "streaks" (so ARV) in AV, ERV Gen 30 37 (*πιπλή*, "peeled spot"); Lev 14 37 (*sh'ka'arūōth*, "hollow places"). For "strake," Tob 11 11; AV Acts 27 17, see STRIKE.

**STRANGE**, strānj, **FIRE** (**אֵשׁ זָרָה**, *'esh zārāh*, "alien fire"): These words are mentioned in connection with the fatal sin committed by the two oldest sons of Aaron, Nadab and Abihu, in "offering strange fire before Jeh" on the occasion of the formal consecration of the Aaronitic priesthood (Lev 10 1.2). The fact is mentioned again in Nu 3 4; 26 61. The greatest calamity of all befell them in that they were cut off childless, which for every true Israelite was the darkest fate imaginable. This fact is mentioned twice (Nu 3 4 and 1 Ch 24 2). The power which cut off the lives of Nadab and Abihu (Lev 10 1.2) is the same as that which shortly before had consumed the consecratory burnt offering (Lev 9 24). What was its true character, whether, as Rosenmüller and Dachselt surmise, it was a lightning stroke or some other supernatural agency, is not worth while debating. It is enough for us to know that "there came forth fire from before Jeh and devoured them." Yet this latter word is not to be taken literally, since they were carried out for burial in their own linen garments (Lev 10 5). They were therefore merely killed, not incinerated. What was their sin? The words "strange fire" have been explained either as common fire, which they placed in their censers, or as unholy incense, which they put thereon (Ex 39 38). But the text plainly points to the former. The sacred fire, once kindled on the altar, was never to be permitted to go out (Lev 6 12 f). When later the temple was dedicated Jeh again lighted the fire on the altar from heaven, as in the case of the dedication of the tabernacle. As, however, the injunction to take fire for the censers of the incense offering only from the coals of the altar is not found before (Lev 16 12), Rosenmüller's observation would seem to be very much to the point: "Quamquam enim in iis quae praecedunt, non extat hoc interdictum, tamen est verisimile Mosem vetasse Aaroni et filiis eius ne ignem alienum altari imponerent." ("For although his injunction does not hold in regard to the preceding cases, yet it is very probable that Moses had forbidden Aaron and his sons to place strange fire upon the altar.") A verbal injunction of Moses must have preceded the fatal mistake. But the text leads us to believe there was more than a mistake here. Some find here the sin of drunkenness, from the enjoined abstinence from any intoxicating drink before the priests thereafter minister before Jeh (Lev 10 9). The likeliest explanation is that, inflated with pride on account of the exaltation of the Aaronitic family above all Israel, they broke unbidden into the ritual of the consecration of the tabernacle and priesthood, eager to take part in the ceremony, and in their haste bringing strange fire into the tabernacle, and thus met their death (see Oehler, *OT Theol.*, 126, 282). The fire burning on the altar came from God, it might never go out, since it represented "the unbroken course of adoration of Jeh, carried on in sacrifice." And this course was interrupted by Nadab and Abihu. The fire on the altar was a symbol of holiness, and they sought to overlay it with unholiness. And thus it became to them a consuming fire, because they approached the Holy One in a profane spirit (cf Isa 33 14).

HENRY E. DOSKER

**STRANGE GODS.** See GODS, STRANGE.

**STRANGE WIFE:** "Strange" as contrasted with "an Israelite." Such wives are spoken of in AV Ezr 10 2.11 (ERV "strange women," ARV "foreign women"); see STRANGER AND SOJOURNER; in the || 1 Esd 8 68—9 37, AV uses "strange wives" and "strange women" indifferently, and RV here follows AV) as "wives of the people of the land," in taking whom the men of Israel are said

to have "trespassed against their God." Accordingly such wives were "put away."

**STRANGE WOMAN:** The Heb גֵר, *zār*, tr<sup>d</sup> "stranger," meant primarily one "who turns aside," i.e. to visit another country; then a "sojourner," "stranger." The "strange woman" of Prov 2 16 is a technical term for "harlot"; cf Jgs 11 1,2, where "son of a strange [RV "another"] woman" (ver 2, 'ahēr) is parallel to "the son of a harlot" (ver 1). See STRANGE WIFE.

### STRANGER, strānj'ēr, AND SOJOURNER (IN THE OT):

- I. THE *gēr*
  1. Legal provisions
    - (1) Principles
    - (2) Rules
  2. Relation to Sacrifice and Ritual
  3. Historical Circumstances
- II. THE *tōshābh*
- III. THE *nokhrī* or *ben nēkhār*
  1. Marriage
  2. Exclusion of Some Races from the Assembly
- IV. THE *zār*

Four different Heb words must be considered separately: (1) גֵר, *gēr*, ARV "sojourner" or "stranger"; (2) תּוֹשָׁב, *tōshābh*, ARV "sojourner"; (3) נֹכְרִי, *nokhrī*, בֶּן נֶכְחָר, *ben nēkhār*, ARV "foreigner"; (4) זָר, *zār*, ARV "stranger."

**I. The *gēr*.**—This word with its kindred vb. is applied with slightly varying meanings to anyone who resides in a country or a town of which he is not a full native land-owning citizen; e.g., the word is used of the patriarchs in Pal, the Israelites in Egypt, the Levites dwelling among the Israelites (Dt 18 6; Jgs 17 7, etc), the Ephraimite in Gibeah (Jgs 19 16). It is also particularly used of free aliens residing among the Israelites, and it is with the position of such that this article deals. This position is absolutely unparalleled in early legal systems (A. H. Post, *Grundriss der ethnologischen Jurisprudenz*, I, 448, n. 3), which are usually far from favorable to strangers.

(1) **Principles.**—The dominant principles of the legislation are most succinctly given in two passages: He "loveth the *gēr* in giving him food and raiment" (Dt 10 18); **Provisions** "And if a *gēr* sojourn with thee [variant "you"] in your land, ye shall not do him wrong. The *gēr* that sojourneth with you shall be unto you as the home-born among you, and thou shalt love him as thyself; for ye were *gērīm* in the land of Egypt" (Lev 19 33 f). This treatment of the stranger is based partly on historic recollection, partly on the duty of the Israelite to his God. Because the *gēr* would be at a natural disadvantage through his alienage, he becomes one of the favorites of a legislation that gives special protection to the weak and helpless.

(2) **Rules.**—In nationality the freeman followed his father, so that the son of a *gēr* and an Israelites was himself a *gēr* (Lev 24 10-22). Special care was to be taken to do him no judicial wrong (Dt 1 16; 24 17; 27 19). In what may roughly be called criminal law it was enacted that the same rules should apply to *gērīm* as to natives (Lev 18 26, which is due to the conception that certain abominations defile a land; 20 2, where the motive is also religious; 24 10-22; see *SBL*, 84 ff; Nu 35 15). A free Israelite who became his slave was subject to redemption by a relative at any time on payment of the fair price (Lev 25 47 ff). This passage and Dt 28 43 contemplate the possibility of a stranger's becoming wealthy, but by far the greater number of the legal provisions regard him as probably poor. Thus provision is made for him to participate in tithes (Dt 14 29; 26 12), gleanings

of various sorts and forgotten sheaves (Lev 19 10; 23 22; Dt 24 19,20,21), and poor hired servants were not to be oppressed (Dt 24 14).

Nearly all the main holy days apply to the *gēr*. He was to rest on the Sabbath (Ex 20 10; 23 12, etc), to rejoice on Weeks and Tabernacles 2. **Relation** (Dt 16), to observe the Day of Atonement (Lev 16 29), to have no leaven and Ritual (Ex 12 19). But he could not keep the Passover unless he underwent circumcision (12 48). He could not eat blood at any rate during the wilderness period (Lev 17 10-12), and for that period, but not thereafter, he was prohibited from eating that which died of itself (Lev 17 15; Dt 14 21) under pain of being unclean until the even. He could offer sacrifices (Lev 17 8 f; 22 18; Nu 15 14 f), and was subject to the same rules as a native for unwitting sins (15 22-31), and for purification for uncleanness by reason of contact with a dead body (Nu 19 10-13).

The historical circumstances were such as to render the position of the resident alien important from the first. A "mixed multitude" went up with the Israelites from Egypt, and after the conquest we find Israelites and the races of Pal living side by side throughout the country. We repeatedly read of resident aliens in the historical books, e.g. Uriah the Hittite. According to 2 Ch 2 17 f (Heb 16 f) there was a very large number of such in the days of Solomon, but the figure may be excessive. These seem to have been the remnant of the conquered tribes (1 K 9 20 f). Ezekiel in his vision assigned to *gērīm* landed inheritance among the Israelites (47 22 f). Hospitality to the *gēr* was of course a religious duty and the host would go to any lengths to protect his guest (Gen 19; Jgs 19 24).

**II. The *tōshābh*.**—Of the *tōshābh* we know very little. It is possible that the word is practically synonymous with *gēr*, but perhaps it is used of less permanent sojourning. Thus in Lev 22 10 it appears to cover anybody residing with a priest. A *tōshābh* could not eat the Passover or the "holy" things of a priest (Ex 12 45; Lev 22 10). His children could be purchased as perpetual slaves, and the law of the Jubilee did not apply to them as to Israelites (Lev 25 45). He is expressly mentioned in the law of homicide (Nu 35 15), but otherwise we have no information as to his legal position. Probably it was similar to that of the *gēr*.

**III. The *nokhrī*.**—The *nokhrī* or *ben nēkhār* was a foreigner. The word is far wider than those considered above. It covers everything of alien or foreign character regardless of the place of residence. By circumcision a foreign slave could enter into the covenant with Abraham. Foreigners were of course excluded from the Passover (Ex 12 43), but could offer sacrifices to Israel's God at the religious capital (Lev 22 25). The Israelite could exact interest of them (Dt 23 20) and the payment of debts in cases where an Israelitish debtor was protected by the release of Dt 15 (ver 3). Moses forbade the appointment of a foreigner as a ruler (Dt 17 15, in a law which according to MT relates to a "king," but in the preferable text of LXX to a ruler generally). Later the worship of God by foreigners from a distance was contemplated and encouraged (1 K 8 41-43; Isa 2 2 f; 56 3,6 f; etc), while the case of Naaman shows that a foreigner might worship Him abroad (2 K 5 17). A resident foreigner was of course a *gēr*. The distinction between these three words is perhaps best seen in Ex 12 43,45,48 f. In the first of these verses we have *ben nēkhār*, used to cover "alien"

generally; in the last the *gēr* is contemplated as likely to undergo a complete naturalization; while in ver 45 the *tōshābh* is regarded as certain to be outside the religious society.

In the earlier period marriages with foreigners are common, though disliked (e.g. Gen 24 3; 27 46 ff; Nu 12 1; Jgs 14 3, etc).

**1. Marriage** The Law provides for some unions of this kind (Dt 21 10 ff; cf Nu 31 18), but later Judaism became more stringent. Moses required the high priest to marry a virgin of his own people (Lev 21 14); Ezekiel limited all descendants of Zadok to wives of the house of Israel (44 22); Ezra and Nehemiah carried on a vigorous polemic against the intermarriage of any Jew with foreign women (Ezr 10; Neh 13 23-31).

Dt further takes up a hostile attitude to Ammonites and Moabites, excluding them from the assembly of the Lord even to the tenth generation, while the children of the third generation of Edomites and Egyptians could enter it (23 3-8 [Heb 4-9]). From 1 K 9 20.21.24; 1 Ch 22 2 we learn of the existence of foreign quarters in Israel.

**IV. The *zār*.**—The remaining word *zār* means "stranger" and takes its coloring from the context. It may mean "stranger in blood," e.g. non-Aaronite (Nu 16 40 [Heb 17 5]), or non-Levite (e.g. 1 51), or a non-member of some other defined family (Dt 25 5). In opposition to priest it means "lay" (Lev 22 10-13), and when the contrast is with holy, it denotes "profane" (Ex 30 9). See FOREIGNER; GENTILE; PROSELYTE; CHERETHITES; PELETHITES; MARRIAGE; COMMERCE.

HAROLD M. WIENER

**STRANGER AND SOJOURNER (IN THE APOC AND NT):** The technical meaning attaching to the Heb terms is not present in the Gr words *trōs* "stranger" and "sojourner," and the distinctions made by EV are partly only to give uniformity in the tr. For "stranger" the usual Gr word is *ξένος, xénos*, meaning primarily "guest" and so appearing in the combination "hatred toward guests" in Wisd 19 13 (*μισοξενία, misoxenia*). *Xénos* is the most common word for "stranger" in the NT (Mt 25 35, etc), but it seems not to be used by itself with this force in the Apoc. Almost equally common in the NT is *ἀλλότριος, allótrios*, "belonging to another" (Mt 17 25.26; Jn 10 5 [*bis*]), and this is the usual word in the Apoc (Sir 8 18; 1 Macc 1 38, etc), but for some inexplicable reason RV occasionally translates by "alien" (contrast, e.g. 1 Macc 1 38; 2 7). Cf the corresponding vb. *ἀπαλλοτριῶ, apallotriōō* (Eph 2 12; 4 18; Col 1 21). With the definite meaning of "foreigner" are *ἀλλογενής, allogenēs*, "of another nation," RV "stranger" (1 Esd 8 83; 1 Macc 3 45 [AV "alien"]); Lk 17 18 [RVm "alien"], and *ἀλλόφυλος, allóphulos*, "of another tribe," RV "stranger" (Bar 6 5; 1 Macc 4 12, etc) or "of another nation" (Acts 10 28). For "to sojourn" the commonest form is *παροικέω, paroikéō*, "to dwell beside," RV always "to sojourn" (Jth 5 7; Sir 41 19; Lk 24 18 [AV "to be a stranger"]); He 11 9). The corresponding noun for "sojourner" is *παροικος, paroikos* (Sir 29 26 f [AV "stranger"]); Acts 7 6.26; Eph 2 19; 1 Pet 2 11), with *παροικία, paroikía*, "sojourning" (Wisd 19 10; Sir 16 8; Acts 13 17 [AV "dwelling as strangers"]); 1 Pet 1 17). In addition, *ἐπιδημέω, epidēmēō*, "to be among people," is *trōd* "to sojourn" in Acts 2 10; 17 21, and its compound *παρεπιδημέω, parepidēmōs*, as "sojourner" in 1 Pet 1 1 (in He 11 13; 1 Pet 2 11, "pilgrim").

BURTON SCOTT EASTON

**STRANGLED,** *stran'g'ld* (קָנַח, *hānak*; πνικτός, *pniktós*, from vb. πνίγω, *pnigō*, "to choke," "to

smother," "to strangle" [cf choking of swine in the lake, Mk 5 13; the seed are choked by the thorns, Mt 13 7; the servant takes his fellow-servant by the throat, AV Mt 18 28]): As adj. "strangled," used of animals deprived of life by choking, and so without the shedding of the blood. Flesh thus killed was forbidden as food among the Hebrews, because it contained the blood (Lev 17 12). Even Jewish Christians in the Jerus council thought it best to forbid things strangled to be eaten by gentile converts, so as not to give offence to Jewish sentiment, and doubtless also to prevent participation in heathen sacrificial feasts (Acts 15 20; 21 25). EDWARD BAGBY POLLARD

**STRANGLING,** *stran'g'ling*. See PUNISHMENTS

**STRAW, strō, STUBBLE, stub'**! The cognates of Heb קָבֵץ, *tebhen*, "straw," and קָשָׁשׁ, *kashsh*, "stubble," have been retained in the modern Arab. terms *tibn* and *kashsh*. *Tibn* applies to the straw which has been cut up into short pieces and more or less split by the threshing operations. It is commonly used throughout the East as a coarse fodder or roughage for domestic herbivorous animals (cf Gen 24 25.32; Jgs 19 19; 1 K 4 28; Isa 11 7; 65 25). Hay and similar cured crops are practically unknown. Barley, peas and other grain, when fed to animals, are mixed with the *tibn*. The animals will frequently reject the *tibn* unless there is grain in it. They often nose about the *tibn* until the grain settles to the bottom so that they can eat the latter without the straw. Straw left in the manger is thrown out in the stall to form part of the bedding (cf Isa 25 10).

*Tibn* is mixed with clay for plastering walls or for making sun-dried bricks. It is also mixed with lime and sand for plastering. The children of Israel had their task of brickmaking made more arduous by being required to gather stubble and prepare it by chopping it up instead of being given the already prepared straw of the threshing-floors (Ex 5 7 ff).

*Kashsh* (lit. "dried up") refers to the stalks left standing in the wheat fields or to any dried-up stalks or stems such as are gathered for burning. Camels and other flocks sometimes supplement their regular meals by grazing on the stubble, otherwise it has no use. In the Bible stubble is used to typify worthless inflammable material (Ex 15 7; Job 13 25; 41 28.29; Ps 83 13; Isa 5 24, etc; 1 Cor 3 12, *καλάμη, kalāmē*).

מִתְבַּן, *mathbēn*, is *trōd* "straw" in Isa 25 10.

JAMES A. PATCH

**STRAWED, strōd:** Past part. of "to strew," "scatter," or "spread about," as powder (of the golden calf, Ex 32 20, RV "strewed"); branches (Mt 21 8, RV "spread"); seed (Mt 25 24.26, RV "scatter").

**STREAM, strēm:** (1) נַחַל, *nahal*, EV "stream," as: "Behold, he smote the rock, so that waters gushed out, and streams overflowed" (Ps 78 20). Often "valley," as "the valley [AV "river"] of the Arnon" (Dt 2 24); or "brook," as "the brook [AV "river"] of Egypt" (Josh 15 4; see Brook or Egypt); or "river," as "the river Kishon" (Jgs 4 7). (2) נָהָר, *nāhār* (Aram. נַהַר, *n'har* [Dnl 7 10];

cf Arab. نَهْر, *nahr*, "river"): "He bindeth the streams," AV "floods" (Job 28 11); "the River" (Euphrates) (Ex 23 31, etc); "Abanah and Pharpar, the rivers of Damascus" (2 K 5 12). (3) פְּלֵגָה, *pelegh*, √ פָּלַג, *pālāgh*, "to split," "to divide," hence "cleft," "channel": "a tree planted by the streams [AV "rivers"] of water" (Ps 1 3); "There is a river,



the streams whereof make glad the city of God" (Ps 46 4); but: "The king's heart is . . . as the watercourses" (AV "rivers of water") (Prov 21 1). (4) אֶפְתָּח, 'aphthak, √ פִּתַּח, 'aphak, "to be strong," hence "channel," "valley," as holding, confining (BDB): "the streams in the South" (Ps 126 4); elsewhere "brook," as "the brooks [AV "rivers"] of Judah" (Joel 3 18); or "channel," as "the channel of brooks" (Job 6 15); or "watercourses" (RVm "ravines," AV "rivers") (Ezk 6 3, etc.). (5) יַאֲרוֹר, *y'ārōr*, from Egyp 'iōtr, 'iō'r, esp. of the Nile, as: "Seven other kine came up after them out of the river" (Gen 41 3); RV "stream," AV "river" (Ex 7 19; 8 5); RV "stream," AV "brook"; "The streams [m "canals"] of Egypt shall be diminished and dried up" (Isa 19 6). (6) יַבְחָל, √ יָבַח, *yābhal*, "to bear along": "brooks and streams of waters" (Isa 30 25); cf יַבְחַל, *yābhal*, "river," "that spreadeth out its roots by the river" (Jer 17 8); אַיְבַּל, 'āybal, "the river Ulai" (Dnl 8 2). (7) נָזַל, *nāzal*, "to flow," "to trickle": "He brought streams also out of the rock" (Ps 78 16). (8) אֶשְׁדָּה, 'eshedh, "the slope of the valleys," AV "the stream of the brooks" (Nu 21 15); cf אֶשְׁדָּרוֹת, 'āshēdhōth, "the slopes" (Josh 10 40); "the slopes [m "springs"] of Pisgah" (Dt 3 17). (9) ποταμός, *potamós*, "The stream brake against that house" (Lk 6 48.49); elsewhere "river," as "the river Jordan" (Mk 1 5). (10) κλύδων, *klūdōn*, "stream," AV Wisd 19 7 (RV "surge"). See BROOK; CANAL; CHANNEL; RIVER; VALE; WATERCOURSE.

ALFRED ELY DAY

STREET, strēt. See CITY.

**STRENGTH, strength, OF ISRAEL:** For "the strength of the children of Israel," applied to Jeh in AV Joel 3 16, RV reads "a stronghold to the children of Israel."

**STRIKE, strik:** The vbs. "to strike" and "to stroke" (latter not in EV) have the same derivation, and originally "strike" was the intrans, "stroke" the trans form. "Strike," however, became used in both senses (always trans in EV), while "to stroke" took on the meaning "to rub gently." But in AV this last force still belonged sometimes to "strike" and is so found in 2 K 5 11, "strike his hand over the place" (RV "wave"), and perhaps Ex 12 7.22; Tob 11 11. Otherwise AV's uses of the simple "strike" are modern, including "strike sail" (Acts 27 17; here and in Tob 11 11 with an archaic preterite "strake," elsewhere "struck"). RV's "They lowered the gear" is a more precise tr, not a modernizing of AV's Eng. The combination "to strike through," however, is not modern Eng., and was used by AV as meaning either "to pierce" (Jgs 5 26; Job 20 24; Prov 7 23; Lam 4 9) or, as an intensive, "to strike violently," "to crush" (Ps 110 5). RV has attempted to distinguish only in Hab 3 14, "pierce," m "smite." "Striking hands" is a common custom at the conclusion of a bargain (Ad Est 14 8), but in Job 17 3; Prov 6 1; 17 18; 22 26; RVm 11 15, the ceremony is used technically for an agreement to be surety for another. Striking (RVm "firing") stones to produce a fire is mentioned (2 Macc 10 3).

The past part. of "strike" is stricken (modern Eng. "struck") (cf Prov 23 35; Jer 5 3; Lam 4 9). So Isa 1 5, "Why will ye be still stricken?" is equivalent to "Why should ye receive any more blows?" (cf 16 7; 63 4.8 m). But in the phrase "stricken in age" (Gen 18 11, etc) "strike" has an older meaning, "advance."

Striker is found in 1 Tim 3 3; Tit 1 7 as a literal tr of *πληκτρης*, *plēktēs*. A hot-tempered man, prone to physical outbursts, is meant. A stroke is simply a "blow," but in Dt 17 8; 21 5, "stroke" is used technically for "assault."

BURTON SCOTT EASTON

**STRINGED**, stringd, INSTRUMENTS. See MUSIC.

**STRIPES**, strips. See PUNISHMENTS.

**STRIVE**, strīv. See GAMES, II, 2.

**STRONGHOLD**, strong'höld. See FORTIFIED CITIES, IV, 1.

**STUBBLE**, stub'l (שָׁבַע, *šābaʿ* [Ex 5 12, etc]; καλάμη, *kalāmē* [Wisd 3 7; 1 Cor 3 12]): These Heb and Gr forms are used of the stalks of wheat, etc, left knee-high in the field by the reapers. תֵּבֶנֶן, *tebhen* (Job 21 18), is a mixture of chopped straw and chaff produced in threshing, which is winnowed out by the fan (cf Jer 23 28; Isa 5 24; Mt 3 12). When *tebhen* was withheld from them the Israelites had to utilize *šābaʿ* for the manufacture of their bricks (Ex 5 12).

**STUDS**, studz (קִדְדוֹת, *qiddōth*, "engraving," "stud"): Ornaments consisting of small silver points which it was proposed (Cant 1 11) to affix to the new golden "plaits" (RV) or "borders" (AV), and which were to replace the strung beads of the bride's necklace.

**STUFF**, stuf (כֶּלִי, *keli*; σκεύος, *skeúos*): "Material" for any purpose (Ezk 12 3.4.7); or "supplies" in a more general sense (Ex 36 7, Heb *m'lā'khāh*; cf AV, ERV 1 S 10 22; 25 13; 30 24 [ARV substitutes "baggage"]); frequently, "household possessions" (Gen 31 37; 45 20; Ex 22 7; Josh 7 11; Neh 13 8; Jth 16 19; AV 15 11 [*skēuás-mata*, RV "furniture"]; AV Lk 17 31, where RV reads "goods"). "Mingled stuff" is the tr of *sha'alnēz* in RV instead of "garment of divers sorts" AV (Dt 22 11).

**STUMBLING-BLOCK**, stum'bling-blok, **STUMBLING-STONE** (מִכְשָׁל, *mikshāl*, מִכְשָׁלָה, *makhshēlāh*; πρόσκομμα, *próskomma*, σκάνδαλον, *skándalon*): These are the most important of the varied renderings of either of two cognate Heb words, or of two different Gr words. Sometimes the Gr word for "stone" (λίθος, *lithos*) accompanies the principal word. There is no important difference in the meaning of the words or of their renderings. RV generally substitutes "stumbling" for "offence" of AV.

The literal meaning of the Heb words—an object which causes one to stumble or fall—appears in such passages as Lev 19 14: "Thou shalt not . . . put a stumblingblock [*mikshāl*] before the blind" (cf Jer 6 21). But the expression is ordinarily figurative, referring to that which causes material ruin or spiritual downfall, which were closely connected in OT thought (Ps 119 165; Ezk 21 15). The things that lead astray are silver and gold (Ezk 7 19); idols (Ezk 14 3; Zeph 1 3, etc).

One of the NT words, σκάνδαλον, *skándalon*, lit. means the stick of a trap to which the bait is attached, and which when touched springs the trap. Figuratively either word refers to a thing or a person that leads one to fall into error, into sin or into destruction: the cross of Christ (Gal 5 11; Rom 11 9); another's liberty (1 Cor 8 9); Peter in Mt 16 23; Christ, whose life and character were so different from Jewish expectation (Rom 9 33). See also OFFENCE.

GEORGE RICE HOVEY

**SUA**, sū'a (Σουά, *Souá*; AV *Sud*): Name of a family of temple-servants who went up from exile with Zerubbabel (1 Esd 5 29) = "Sia" of Neh 7 47; "Siaha" of Ezr 2 44.

**SUAH**, sū'a (סוּחַ, *sū'ah*): Son of Zophah, of the tribe of Asher (1 Ch 7 36).

**SUBAI**, sū'bā-ī, sū'bī (Συβαί, *Subaēi*): Name of a family of temple-servants who returned with Zerubbabel (1 Esd 5 30) = "Shamlai" of Ezr 2 46; "Salmāi" of Neh 7 48.

**SUB-APOSTOLIC LITERATURE**. See **LITERATURE**, **SUB-APOSTOLIC**.

**SUBAS**, sū'bas (Σουβάς, *Soubás*; AV *Suba*): Name of a family of "the sons of the servants of Solomon" returning with Zerubbabel (1 Esd 5 34), wanting in the || lists of Ezr 2 57; Neh 7 59.

**SUBORN**, sub-ōrn' (ὑποβάλλω, *hypobállō* [Acts 6 11; only here in the NT]): The word means to introduce by collusion, to put one person in the place of another, to employ anyone in a secret manner and instruct such a one to act for and as though he were another person.

**SUBSTANCE**, sub'stans (ὑπόστασις, *r'khūsh*; ὑπόστασις, *hypóstasis*): Lit. that which stands under, is in the Bible used chiefly of material goods and possessions. In the OT it is the tr of numerous Heb words, of which *r'khūsh*, "that which is gathered together," is one of the earliest and most significant (Gen 12 5; 13 6; 15 14; 1 Ch 27 31; Ezr 8 21, etc). In the NT "substance" appears in a few passages as the tr of *ousia*, "being," "subsistence" (Lk 15 13), *húparxis*, "goods," "property" (He 10 34), *hypárchonta*, "things at hand" (Lk 8 3). Special interest attaches to He 11 1, AV "Now faith is the substance of things hoped for," etc, where the word is used in its proper etymological sense as the tr of *hypostasis*, "that which stands under." RV changes to "assurance," m "the giving substance to," which last seems best to bring out the idea of faith as that which makes the things hoped for real to the soul. The same Gr word *hypostasis* is rendered "substance" in He 1 3 RV, instead of AV "person," with reference to Christ, "the very image [m "impress"] of his substance," i.e. of God's invisible essence or being, the manifestation of God Himself. W. L. WALKER

**SUBTIL**, sub'til, **SUBTLE**, sut'1, **SUBTLETY**, sut'1-ti, **SUBTILTY** (ἡκχᾶμ, *hākhām*, נָכְל, *nākhāl*, מִרְמָה, *mirmāh*; δόλος, *dólos*): These words are used (1) in a good sense: 2 S 13 3, *hākhām*, "wise," "Jonadab was a very subtil [ARV "subtle"] man" (discreet); Prov 1 4, *ormāh*, "prudence," "to give subtilty to the simple," ARV and ERV "prudence"; Wisd 7 22, *leptōs*, "thin," said of the spirit in Wisdom (very fine or refined); 8 8, *strophē*, "winding," "subtilties of speeches"; Ecclus 39 2, "subtil parables," RV "the subtilties of parables"; (2) in a bad sense: Gen 3 1, *ārūm*, "crafty," "Now the serpent was more subtil than any beast of the field," ARV "subtle."

Gen 27 35, *mirmāh*, "deceit," "fraud," "Thy brother came with subtilty," RV "with guile"; Ps 105 25, *nākhāl*, "to deceive," AV "deal subtilly," ARV "subtly"; Prov 7 10, *nāzar*, "to watch," "guard," "to be hidden or subtle of heart," RV "wily," m "close," Heb "guarded"; 2 K 10 19, *okēbhāh*, "deceit" or "treachery" (here only); Jth 5 11, *katasophizō*, "to use subtilty"; Ecclus 19 25, *panourgta*, "cunning," "unscrupulousness," "There is an exquisite subtilty, and the same is unjust"; 2 Cor 11 3, "The serpent beguiled Eve through his subtilty," RV "in his craftiness";

Mt 26 4, *dolos*, "deceit," "that they might take Jesus by subtilty, and kill him"; Acts 13 10, "O full of all subtilty and all mischief," RV "all guile and all villany."

ERV has "subtily" for "wisdom" (Prov 8 5.12), m and ARV, "prudence"; for "with subtilty" (ERV Mk 14 1, AV "by craft") ARV has "with subtilty." W. L. WALKER

**SUBURBS**, sub'urbz. See **CITY**.

**SUBVERT**, sub-vurt' (ὑβρίζω, *āwath*; ἀνατρέπω, *anatrepō*): Occurs 5 t: (1) in the sense of overturning, etc, as the tr of *āwath*, "to make bent or crooked" (Lam 3 36), "to subvert a man in his cause"; of *anaskēuizō*, primarily, "to pack up baggage"; then, "to ravage," etc (Acts 15 24, "subverting your souls"); of *anatrepō*, "to turn upside down," "to overturn" (Tit 1 11, "who subvert whole houses," RV "overthrow"); of *katastrōphē*, "overthrow," "destruction" (2 Tim 2 14, "to the subverting of them that hear"); (2) in the sense of perverting: *ekstrēphō*, "to turn or twist out," "to turn about" (Tit 3 11, "such is subverted," RV "perverted"). For "overthrown me" (Job 19 6) RV has "subverted me [in my cause]," m "overthrown me"; for "perverteth" (Prov 19 3), "subverteth." W. L. WALKER

**SUCATHITES**, sū'kath-its (שִׁכְתִּיּוֹת, *sūkhāthim*; Β, Σωκαθίται, *Sōkathieim*, Α, Σωκαθίται, *Sōkathieim*; AV *Suchathites*): These are named only once (1 Ch 2 55), a family of scribes living at Jabez.

**SUCCEED**, suk-sēd', **SUCCESS**, suk-ses' (יָרַשׁ, *yārash*, שָׂכַל, *sākhāl*; εὐμερία, *euēmeria*): "To succeed" means, (1) and originally, "to follow after"; (2) mostly in modern Eng., "to prosper"; in AV, with one exception, the word has a qualifying adjective. (1) In the first sense it is the tr of *yārash*, "to seize" or "to take possession" (Dt 2 12; 12 29, ARV "dispossesest," ERV "possesest"); of *kūm*, "to rise up" (Dt 25 6, "shall succeed in the name of his brother"); of *diadēchomai* (Ecclus 48 8, "prophets to succeed after him"). (2) In the sense of prospering, "success" is the tr of *sākhāl*, "to be wise," "to prosper" (Josh 1 8, "Thou shalt have good success," AVm "do wisely," RVm "deal wisely"; cf AVm Job 22 2; Ps 111 10; Prov 3 4); "good success" occurs in Tob 7 12, *euodōsei tā kālīsta*; Wisd 13 19, *epituchia*; Ecclus 20 9, *euodia*, RV "prosperity," "There is a prosperity that a man findeth in misfortunes; and there is a gain that turneth to loss"; 38 13, *euōdia* (so N C—this word = "sweet savor," "fragrance"; cf Phil 4 18; Eph 5 2; 2 Cor 2 15). See further **EUODIA**. RV "the issue for good"; 1 Macc 4 55, *euodōō*; 8 23, *kalōs*, etc. "Success," simply (as "prosperity," *euēmeria*), 2 Macc 10 28, "a pledge of success and victory"; "successor" occurs (Ecclus 46 1, "Joshua . . . was the successor [*diadochos*] of Moses"); 2 Macc 9 23; 14 26). W. L. WALKER

**SUCCOR**, suk'ēr, **SUCCORER**, suk'ēr-ēr (יָצַר, *āzar*; βοηθέω, *boēthēō*, προστάτης, *prostātis*): Is the tr of *āzar*, "to gird" (2 S 8 5, etc); of *boēthēō*, "to come in aid of" (2 Cor 6 2, "In a day of salvation did I succor thee"; He 2 18, "He is able to succor them that are tempted"); of *prostatis*, "one standing before" (Rom 16 2, ARV "helper of many"); of *antilepsis* (Ecclus 51 7, AV "I looked for the succour of men, but there was none"); of *phugaderition* (1 Macc 1 53, "flee for succor," RV "place of refuge"); of *sōzō* (2 44, "for succor," RV "for safety"); of *skēpē* (2 Macc 5 9, RV "shelter"); "succors" occurs (Wisd 17 12, AV *boēthēma*, "for

fear is nothing else but a betraying [RV "surrender"] of the succours which reason offereth"); "succoreth" (1 Macc 12 15, *boēthēō*, "help from heaven that succoreth us," RV "to help us"). RV has "succor" for "help" (1 Ch 18 5); "O thou my succor," for "O my strength" (Ps 22 19). W. L. WALKER

**SUCCOTH**, suk'oth, suk'ōth (סֻכּוֹת, *ṣukkōth*, "booths"; Σκηναι, *Skenai*, Σοκχῶθ, *Sokchōth*, etc): After parting with Esau, Jacob journeyed to Succoth, a name which he gave to the place from the "booths" which he erected to shelter his cattle (Gen 33 17). It was in the territory of Gad, and is mentioned with Beth-nimrah (Josh 13 27). In his pursuit of Zeba and Zalmunnah, Gideon seems to have retraced the path followed by Jacob, passing Succoth before Penuel (Jgs 8 5 ff). Their churlishness on that occasion brought dire punishment upon the men of Succoth. Gideon on his return "taught them" with thorns and briers (ver 16). In the soil of the valley between Succoth and Zarethan, which was suitable for the purpose, the brass castings of the furniture for Solomon's Temple were made (1 K 7 46; 2 Ch 4 17). Jerome (on Gen 33 17) says that in his day it was a city beyond Jordan in the district of Scythopolis. From the above data it is clear that Succoth lay on the E. of the Jordan and N. of the Jabbok. From Ps 60 6; 108 7, we may infer that it was close to the Jordan valley, part of which was apparently known by its name. Neubauer (*Géog. du Talm.*, 248) gives the Talmudic name as *Tar'ala*. Merrill (*East of the Jordan*, 386) and others compare this with *Tell Deir 'Allā*, the name of an artificial mound about a mile N. of the Jabbok, on the edge of the valley, fully 4 miles E. of the Jordan. There is a place called *Sakūt* W. of the Jordan, about 10 miles S. of *Beisān*. This has been proposed by some; but it is evident that Succoth lay E. of the river. No trace of the name has been found here.

W. EWING

**SUCCOTH** (סֻכּוֹת, *ṣukkōth*; Σοκχῶθ, *Sokchōth* [Ex 12 37; 13 20; Nu 33 5]): The first station of the Hebrews on leaving Rameses (see EXODUS). The word means "booths." The distance from ETHAM (q.v.) suggests that the site may have lain in the lower part of *Wādī Tumeilat*, but the exact position is unknown. This region seems possibly to have been called *T-K-u* by the Egyptians (see PITHOM). Brugsch and other scholars suppose this term to have been changed to Succoth by the OT writer, but this is very doubtful, Succoth being a common Heb word, while *T-K-u* is Egypt. The Heb *ṣ* does not appear ever to be rendered by *t* in Egypt. The capital of the Sethroitic nome was called *T-K-t* (Pierret, *Vocab. hiéroglyph.*, 697), and this word means "bread." If the region of *T-K-u* was near this town, it would seem to have lain on the shore road from Edom to Zoan, in which case it could not be the Succoth of the Exodus. C. R. CONDER

**SUCCOTH-BENOTH**, suk'oth, -ōth-bē'noth, -nōth (סֻכּוֹת בְּנוֹת, *ṣukkōth b'nōth*; Ποκχῶθβανυειθελ, *Rhochōthbaineithel*, A [better], Σοκχῶθβενιθει, *Sokchōthbenithēi*): The name of an idol made by the Babylonians sent into exile at Samaria by an Assyrian king (Shalmaneser), and mentioned among the deities of the various nationalities there assembled (2 K 17 30). In Heb, Succoth-benoth means "booths of daughters," and has been explained as the chambers wherein the Babylonians placed women for prostitution; or booths or tabernacles in which images of certain goddesses were worshipped.

The parallelism, however, requires a deity, like the Nergal of the Cutheans, the Ashima of the Hamathites, etc, and not a chamber or shrine. This consideration caused Rawlinson's Sir H. Rawlinson to suggest an identification of Succoth-benoth with the Babylonian *Zēr-panthum* (= *Zēr-banīthum*), whose name was probably pronounced *Zēr-panth*, the spouse of Merodach (the god of Babylon), as the "seed-creatress." The difference in the first component, *zēr*, was regarded as due to its possible Hamitic (=Sumerian) equivalent, or to a Sem translation, both of which explanations are now known to be untenable.

As the people who made Succoth-benoth were Babylonians, we should expect here either a name of Merodach, the god of Babylon, or one of the deities identified with him. At present the only suggestion which can be made is that Benoth is for Sakut?

בָּן וָת, *ban wāth*, i.e. *ban'(i) mātī*, "creator of the land." Both the Sem and the bilingual creation-stories speak of Merodach as the creator of the world, with its products, and the great cities of Babylonia; and "father Enlil," who bore the title "lord of the world," bestowed the same upon Merodach at the creation, thus identifying Merodach with himself. Now there is a group which may be read either *Dikut*, "the Judge," or *Sakut*, "the Counsellor," and if we can read Succoth-benoth as *Sakut(h)ban' wāt(h)*, "the Counsellor, creator of the land," a satisfactory explanation of this puzzling name will be furnished. The terminal *i* of the Bab has been preserved in the *ei*, of the Gr. The adoption of such a descriptive name of Enlil-Merodach would form a compromise between abandoning their old objects of worship and accepting "the god of the land" (2 K 17 26).

T. G. PINCHES

**SUCHATHITES**, sū'kath-its. See SUCATHITES.

**SUD**, sud: AV=RV SUA (q.v.).

**SUDIAS**, sū'di-as (Σουδίας, *Soudias*): In 1 Esd 5 23, a Levitical family that returned with Zerubabel, called in Ezr 2 40 "Hodaviah" and in Neh 7 43 "Hodevah" (q.v.).

**SUFFERING**, suf'ēr-ing: A great variety of Heb and Gr expressions, too large to be here enumerated, have been tr'd by "suffering" and other forms derived from the same vb. The most obvious meanings of the word are the following: (1) The commonest meaning perhaps in the EV is "to permit," "to allow," "to give leave to": "Moses suffered to write a bill of divorce, and to put her away" (Mk 10 4). (2) "To experience," "to go through," "to endure": "I have suffered many things this day in a dream because of him" (Mt 27 19). A woman "had suffered many things of many physicians" (Mk 5 26). Other common phrases are "to suffer affliction" (1 Thess 3 4; He 11 25, RV "share ill-treatment"), "to suffer hardship" (2 Tim 2 9), "to suffer adversity" (He 13 3 AV, RV "to be ill-treated"), "to suffer dishonor" (AV "shame," Acts 5 41), "to suffer violence" (Mt 11 12), "to suffer wrong" (Acts 7 24), "to suffer terror" (Ps 88 15), "to suffer shipwreck" (2 Cor 11 25), "to suffer hunger" (Ps 34 10; Prov 19 15), "to suffer thirst" (Job 24 11). (3) "To put up with," "to tolerate": AV, "For ye suffer fools gladly [RV "ye bear with the foolish gladly"], seeing ye yourselves are wise" (2 Cor 11 19). (4) "To undergo punishment": "Think ye that these Galileans were sinners above all the Galileans, because they have suffered these

things?" (Lk 13 2). (5) "To sustain loss": "If any man's work shall be burned, he shall suffer loss" (1 Cor 3 15; also Phil 3 8). (6) "To suffer death." Here the clearest references are to the suffering or passion of Christ, which indeed includes the enduring of untold hardships and affliction, all of which culminate in His vicarious death for man (Mt 16 21; Mk 8 31; 9 12; Lk 9 22; 17 25; 22 15; 24 26,46; Acts 3 18; 17 3; 26 23; 1 Pet 3 18).

Suffering belongs to the discipline of all Christ's followers (Rom 8 17; 2 Cor 1 7; Gal 3 4; Phil 3 10; 1 Thess 2 2; 2 Thess 1 5; 2 Tim 2 12; 3 12; Jas 5 10; 1 Pet 2 20 f; 3 14,17; 4 1,13,16; 5 10). Such suffering is called a suffering for God's or Christ's sake (Jer 15 15; Acts 9 16; Phil 1 29; 2 Tim 1 12). This fellowship in suffering unites us with the saints of God in all times (Jas 5 10), and is indeed a fellowship with the Lord Himself (Phil 3 10), who uses this discipline to mold us more and more according to His character.

H. L. E. LUERING

**SUFFOCATION**, suf-ô-kâ'shun. See PUNISHMENTS.

**SUICIDE**, sū'i-sid. See CRIMES.

**SUKKIIM**, suk'i-im (סֻכִּיִּים, *sukkīyīm*): Named in 2 Ch 12 3 as a tribe that took part with Libyans and Cretons in the invasion of Judaea by Shishak. The identification is uncertain.

**SULPHUR**, sul'fur. See BRIMSTONE.

**SUMMER**, sum'ēr (צִיָּץ, *kayīç*; Aram. קִיָּץ, *kayīç* [Dnl 2 35], from קָץ, *kūç*, קִיָּץ, *kūç*, "to cut off," "to pluck or gather fruit," hence the time of fruit, summer [2 S 16 1,2; Jer 40 10,12]; θέρος, *théros* [Mt 24 32; Lk 21 30]): The Heb vb., mentioned above, occurs in Isa 18 6, "to summer," used of the ravenous birds feeding upon carcases of the slain. The term "summer parlor" in Jgs 3 20 (cf ver 24) is lit. "upper room," and is so rendered in RV. The summer was the dry season extending from April to October when usually no rain falls. Hence the "drought of summer" (Ps 32 4). See SEASONS.

H. PORTER

**SUMMER-HOUSE** (בֵּית הַקִּיָּץ, *bēth ha-kāyīç*): Am 3 15 notes it as part of the judgment on Israel that Jeh would smite "the winter-house with the summer-house." It belonged to the luxury of the period that kings and wealthy persons had separate residences for the cold and hot seasons. This is the only mention of "the summer-house," but Eglon's "cool upper room" (Jgs 3 20, AV and ERV "summer parlour," not in this case a separate building) may be compared. See WINTER-HOUSE.

**SUN**. See ASTRONOMY, I, 2.

**SUN** (Figurative): Poetical conceptions for the sun are frequently found in the Scriptures, though the strictly figurative expressions are not common. Undoubtedly the Jewish festivals, religious as well as agricultural, were determined by the sun's movements, and this fact, together with the poetical nature of the Hebrews and their lack of scientific knowledge, had a tendency to multiply spiritual and metaphorical expressions concerning the "greater light" of the heavens. Some of these poetical conceptions are very beautiful, such as the sun having a habitation (Hab 3 11), a tabernacle (Ps 19 4 f) set for him by Jeh, out of which he comes as a bridegroom from his chamber, rejoicing as a strong man to run a race. The sun is also

given as the emblem of constancy (Ps 72 5,17), of beauty (Cant 6 10), of the law of God (Ps 19 7), of the purity of heavenly beings (Rev 1 16; 12 1), and of the presence and person of God (Ps 84 11). The ancient world given to personifying the sun did not refrain from sun-worship, and even the Hebrew in the time of the kings came perilously near this idolatry (2 K 23 11). See SUN-WORSHIP.

C. E. SCHENK

**SUN, CHARIOTS OF THE**. See HORSES OF THE SUN.

**SUN GATE**. See EAST GATE.

**SUN, HORSES OF THE**. See HORSES OF THE SUN.

**SUN-IMAGES**. See IMAGES.

**SUNDAY**, sun'dā. See LORD'S DAY.

**SUNRISING**, sun'riz-ing: A frequent designation in the OT for the East (Nu 21 11; Dt 4 41,47; Josh 1 15, etc). In Rev 7 2, RV has "sunrising" for AV "east."

**SUN, SMITING**, smit'ing, BY: Exposure of the uncovered head to the heat of the sun is likely to produce either of two conditions; the commoner is heat exhaustion with faintness, the rarer is heat-stroke with fever and paralysis of the heat-regulating apparatus of the nervous system. This condition is described as *siriasis*. The two fatal instances recorded were probably of the latter kind. One, the case of the Shunammite's son (2 K 4 19), was apparently very acute, like some of the cases described by Manson and Sambon. Of the other case, that of Manasseh, Judith's husband, we have no particulars (Jth 8 3), except that it was likewise brought on by exposure in the harvest field, and occurred at the time of barley harvest, that is, early in May. Jonah's attack was one of heat syncope, as he fainted from the heat (Jon 4 8). According both to psalmist (Ps 121 6) and to prophet (Isa 49 10), the people of God are protected from the stroke of the sun as well as from that of the moon. The latter was supposed to cause lunacy (hence the name), and epilepsy, so in Mt 4 24 the word rendered "lunatic" (AV for "epileptic" (RV) is *selēniazomēnous*, lit. "moon struck." See MOON.

ALEX. MACALISTER

**SUNSTROKE**, sun'strök. See SUN, SMITING BY.

**SUN-WORSHIP**, sun'wūr-ship: The splendor of the sun makes it a natural object of adoration, once the purer idea of the one true God (Rom 1 20, 21) is parted with, and in most ancient nations the worship of the sun was an outstanding feature. It is found in Bab and Assyr (*Samaš*; special seats of sun-worship were Sippara and Larsa); in Egypt it is a leading feature of the religion (Ra, and, under special phases, Horus, Tum, Aten; a special seat of sun-worship was Heliopolis, the OT On, called in Jer 43 13 Beth-shemesh, "house of the sun"). Other cities bore the same name: Beth-shemesh (Josh 15 10=Ir-shemesh; 19 41, in Judah; Josh 19 22, in Issachar; 19 38, in Naphtali; see BETH-SHEMESH). Allusions to, and warnings against, sun-worship are frequent in the OT, as in Lev 26 30; 2 Ch 14 5; 34 4,7; Isa 17 8; 27 9; Ezk 6 4,6, in which passages for AV "images," "idols," RV has "sun-images" (q.v.); Job 31 26,27 and numerous passages show that this form of idolatry latterly penetrated deeply into Judah—even into its temple-worship (2 K 23 5,11, "horses . . . given to the sun" [see under HORSES OF THE SUN,

"Chariots of the Sun"]; and Ezk 8 16). Josiah's reformation took account of these abuses (2 K 23 5.11 ff; 2 Ch 34 4.7), and Ezekiel strenuously denounced them (8 16 ff). JAMES ORR

**SUP, SUPPER**, sup'ēr. See MEALS.

**SUPERFLUOUS**, sū-pūr'flood-us, **SUPERFLUITY**, sū-pēr-flood'i-ti (שָׂרָא; *sāra*; περισσός, *perissós* [2 Cor 9 1], *περισετα*, *perisseta*): According to the Levitical Law, "a blind man, or a lame, or he that hath a flat nose, or anything superfluous" could not fulfil priestly functions (Lev 21 18; 22 23). According to Dillmann (Baentsch, *BDB*) the word should be rendered "a limb too long," but Ewald (following the LXX) suggests "having cropped ears." The only instance of **superfluity** occurs in Jas 1 21, AV "superfluity of naughtiness"; according to Mayor "overflowing ebullition of malice" (RV "overflowing of wickedness," m "malice"); but the Gr word is used in other connections, e.g. of "grace" (Rom 5 17); "joy" (2 Cor 8 2). T. LEWIS

**SUPERSCRPTION**, sū-pēr-skip'shun (ἐπιγραφή, *epigraphē*): (1) The legend on a coin designating the person in whose honor or by whose authority it is issued (Mt 22 20; Mk 12 16; Lk 20 24). (2) The accusation on the cross of Jesus (Mk 15 26; Lk 23 38). According to Rom custom an inscription bearing the charge or ground of a criminal's condemnation was fixed to the cross on which he was crucified. The use of such an inscription at the crucifixion of Jesus is mentioned by all four evangelists. The fullest description is that of Mark, "the superscription of his accusation" (ἡ ἐπιγραφή τῆς αἰτίας αὐτοῦ, *hē epigraphē tēs aítias autou*) (15 26). Matthew calls it more briefly "his accusation" (τὴν αἰτίαν αὐτοῦ, *tēn aítian autou*) (27 38), while Luke styles it merely "a superscription" (*epigraphē*) (23 38). In the Fourth Gospel it is called a "title" (τίτλον, *títlon*) (Jn 19 19). The text of the superscription is given by the four evangelists in varying terms and with various degrees of fulness. RUSSELL BENJAMIN MILLER

**SUPERSTITION**, sū-pēr-stish'un, **SUPERSTITIOUS**, sū-pēr-stish'us (δεισιδαιμονία, *deisidaimonía*, "fearing demons"): The Bib. use of these words is limited to that of the former in Acts 25 19 AV, and of the latter in Acts 17 22. In the former reference, Festus speaks of the Jews' "superstition" (RV "religion"), thus artfully dodging an avowal of his own convictions "respecting the Heb faith." In Acts 17 22 AV Paul tactfully refers to the Athenians as being "too superstitious" (RV "too religious"), thus using the term correctly from both their and his point of view. They were truly too "religious" with their superstitions. LEONARD W. DOOLAN

**SUPH**, sōf (סוּף, *sūph*; πηλοῦν τῆς ἐρυθρᾶς [θαλάσσης], *plēsion tēs eruthrās [thalássēs]*; AV Red Sea): As the verse stands, the place where Moses addressed the children of Israel is indicated as "beyond the Jordan in the wilderness, in the Arabah over against Suph" (Dt 1 1). AV, following LXX, takes the name as a contraction of *yām sūph* (see RED SEA). The abbreviation is not found elsewhere. The name of the sea was not derived from that of a city; so we need not look in that direction. Knobel suggested *Nakh es-Safā*, a pass about 25 miles W.S.W. of the Dead Sea. But it is "unsuitably situated; nor does the name agree phonetically (for *ص* agrees with *ס*, not with *פ*)" (Driver, "Dt," *ICC*, 4). No identification is possible. W. EWING

**SUPHAH**, sōf'fā (סוּפָה, *sūphāh*, for סוּפָה בְּהַר הַיַּבֵּשׁ, *wāhēbh b'sūphāh*; LXX reads τὴν Ζωὴν ἐφλόγιση, *tēn Zōōn ephlōgise*; AV Rea Sea): Suphah is the region in which Vaheb is situated (Nu 21 14). It is probably identical with Suph of Dt 1 1. Tristram (*Land of Moab*, 50 f) suggested identification with *Ghōr es-Sāfiyeh*, a small oasis E. of the mud flats of *Es-Sebkhalah*, S. of the Dead Sea; but "the sibilants do not correspond, and *Sāfiyeh* is a specifically Arab. term (Wetzstein in Delitzsch, *Gen*, 586, n. 2) which does not seem to be a likely explanation of Suphah" (Gray, "Nu," *ICC*, 285 f). This, and other questions of identification, must wait for solution until a more thorough exploration of the whole district has been accomplished. W. EWING

**SUPPER**, sup'ēr. See MEALS.

**SUPPER, LORD'S**. See LORD'S SUPPER.

**SUPPLY**, su-pli': Phil 4 19 for πληρῶ, *plērōō*; 1 Cor 16 17; Phil 2 30 for ἀναπληρῶ, *anaplērōō*; 2 Cor 9 12 (AV); 11 9 for προσαναπληρῶ, *prosanaplērōō*. All three vbs. mean "to fill," the 3d containing the additional connotation "fill up to a certain point." Eph 4 16; Phil 1 19 for the noun ἐπιχορηγία, *epichorēgia*, lit. "an additional supply." But no special force of "additional" seems to be contained in the passages. In 2 Cor 9 10a; Gal 3 5; Col 2 9; 2 Pet 1 5.11, we have ἐπιχορηγέω, *epichorēgēō*, "to furnish besides," i.e. fully supply; in 2 Cor 9 10b; 1 Pet 4 11 the simple *chorēgēō*, "to furnish." BURTON SCOTT EASTON

**SUR**, sūr (B, Ἀσσοῦρ, *Assour*, A, Σοῦρ, *Sour*): Those that dwelt in Sur are mentioned along with the inhabitants of Sidon, Tyre, Oeina, etc, as dreading the approach of Holofernes and the Assyrian army (Jth 2 28). The names run from N. to S., and Sur immediately follows Tyre (modern *Šūr*), with which, therefore, it can hardly be identified. No probable identification has been suggested. See also JERUSALEM.

**SURE**, shōōr, **SURELY**, shōōr'li: In modern Eng. is used chiefly in the phrases "to be sure" or "to make sure," and as a simple adjective it is usually either archaic or exceedingly colloquial. The adjectival use, however, is common (chiefly for אָמַן, *āman*, "to confirm," and its derivatives) in EV, where modern Eng. would prefer "secure" or "certain" (1 S 2 35; Sir 40 25; Acts 13 34, etc). "To be sure that" is also fairly common in AV, and occasionally (as in Dt 12 23, "Be sure that thou eat not the blood," for הָזַק, *hāzak*, "to be firm") it has rather more emphasis than in modern Eng. But usually the phrase is a mere periphrasis for some word meaning "to know" (cf RV Ex 3 19; Lk 10 11; Rom 2 2, etc). In Prov 6 3, AV has "Make sure thy friend" for רָהַב, *rāhabh*, "be boisterous" "beset," RV "importune." The sense is "Force him to pay his debt."

**Surely** in EV is used almost always to qualify an entire phrase, as in Gen 28 16, "Surely Jeh is in this place." In modern Eng. "surely" used in this way suggests that the statement is being argued and is therefore slightly doubtful, but in Elizabethan Eng. the purpose is to exclude all doubt ("beyond question"). With this force AV uses "surely" to translate almost any emphatic form, and RV has conformed to AV's use, and such changes as have been made by RV (Mt 26 73; Lk 4 23; Rev 22 20, etc) are merely to preserve uniformity of rendition. The most common use of "surely" in this sense is to translate a vb. when emphasized by its own part. (absolute inf. in Heb), as "Thou shalt

surely die" (Gen 2 17) for "dying thou shalt die" (cf Gen 22 17 for the Heb construction). In this sense "surely" is sometimes varied by "of a surety" (Gen 15 13, etc) without the slightest difference in meaning (cf Gen 9 5 and 26 9). In addition, "surely" is used occasionally as a simple advb. where modern Eng. would prefer "securely" or "certainly" (cf Prov 10 9 and AV Lk 1 1, "surely believed," RV "fulfilled," RVm "fully established").

Surety, besides its use in "of a surety" appears in the OT to translate עֲרָב, 'arabh, "to be surety," and in He 7 22 for ἑγγυος, ἑγγυος, "guarantor," "giver of security." Modern Eng. prefers "security," as does even AV in Acts 17 9. "Suretiship" (ARV "suretyship") in Prov 11 15 for יָדָא, tāka, "to strike [hands]." See STRIKE; SURETY.

BURTON SCOTT EASTON

**SURETY**, shōor'ti: This word is used in three different connections or groups:

(1) *As a derivative of the word "sure" it means "of a certainty" or "surely."*—In Gen 15 13 the infinitive absolute of the vb. is used to give emphasis to the idea of the vb. and is rendered "of a surety." In Gen 18 13 the Heb 'omnām is tr<sup>d</sup> "of a surety." In Gen 26 9 'akh is similarly rendered, and has the force of our "indeed." In Acts 12 11 ἀληθῶς, alēthōs, is tr<sup>d</sup> in AV "of a surety," but better in RV "of a truth."

(2) *In the sense of security or pledge for a person.*—This means that one person may become security for another, that such a one will do a certain thing at a time in the future. Judah was "surety" to his father Jacob that Benjamin would safely return from Egypt (Gen 43 9). He pledged his life that the younger brother would return safely. He tells Joseph (Gen 44 32) how he had become surety for Benjamin, and offers to become Joseph's slave for the sake of his brother. Job says (Job 17 3), "Give now a pledge, be surety for me with thyself; who is there that will strike hands with me?" The striking of hands refers to the action or gesture by which the surety or pledge was publicly manifested and thus ratified. Job here beseeches God to become surety for him, to pledge him that some time in the future He will cause Job's innocence to be made known and be acknowledged by God Himself. In Isa 38 14 Hezekiah says, "O Lord, I am oppressed, be thou my surety." He wishes God to give him a pledge of some kind, to go security for him in such a way that he will surely be saved out of his sickness and distress. Jesus is called "the surety [ἑγγυος, ἑγγυος] of a better covenant" (He 7 22). Jesus is the pledge or surety that through Him we may obtain the assurance and certainty that a more excellent covenant has been established by God, and are assured also of the truth of the promises connected with it.

(3) *It is used to describe the practice of going security for another by striking hands with that person and becoming responsible for money or any object loaned.*—The Book of Prov unhesitatingly condemns the practice. No mention is made of it in the Mosaic Law, as if the custom were then practically unknown. The Book of Prov makes no distinction between a stranger and a neighbor; the person who does such a thing is likened unto an animal caught in a trap. He is exhorted to sleep no more until he has got out of the trap, or freed himself from this obligation (Prov 6 1-5). The wisdom of such advice has been abundantly verified by experience. It does not necessarily preclude certain special cases, where the practice may be justified. The international relationships of the Jews in the period of the monarchy, together with the unsettled condition of the country (Neh 5 3) and people, needed such commercial strictness.

Their trade was mostly in the hands of the Phoenicians and other foreigners, and the pressure of taxation for the payment of foreign tribute, etc, was heavy (Neh 5 4 f). Prov 11 15; 17 18 declare one "void of understanding" who thus goes security for another. Prov 20 16 seems to contain an exclamation of contemptuous rebuke for the man who goes security. Prov 22 26; 27 13 contain like admonitions. See DEBT; PLEDGE; SECURITY; STRIKE.

JAMES JOSIAH REEVE

**SURNAME**, sūr'nām (קָנָה, kānāh; ἐπικαλεῖν, epikalein): A word derived from the Fr., meaning "an additional name"; in modern Eng. always the family name of a person. Indeed, the spelling "surname" in AV 1 Macc 1 10; 2 2; 6 43 may be due to a confusion with "sire's name." But the custom of family names was entirely unknown among the Hebrews. The word is used twice in AV of the OT, viz. Isa 44 5; 45 4. The Heb word means "to give flattering or honorary titles." In the former passage foreigners are so envious of the prosperity of the Jews that they are anxious to be surnamed by the name of Israel, i.e. to be enrolled as members of the Jewish nation. In the latter case Jeh gives Cyrus an honorary title, viz. "servant of Jeh," and thus appoints him to be His instrument in the restoration of His people. The same word is rendered in Job 32 21, AV "give flattering titles." Elihu declares his intention to examine the situation without fear or favor. He will not allow such high-sounding titles as "Your Worship" or "My Lord" to stand in his way. He will not be overawed by Job's social position. In the NT the word is used in the case of Peter—Simon whose surname is Peter (Acts 10 5,32; 11 13); of Mark—John whose surname was Mark (Acts 12 12, 25; 15 37); of Judas—surnamed Iscariot (Lk 22 3); of Barsabbas—who was surnamed Justus (Acts 1 23); and of Judas—surnamed Barsabbas (Acts 15 22). It was a widespread custom in the ancient world to give honorary and symbolical titles. Our Lord surnamed Simon Peter (Mk 3 16), and James and John Boanerges (Mk 3 17). Acts 15 37 AV has "surname" for the simple "call" (so RV).

T. LEWIS

**SUSA**, sū'sa, sōō'sa (Ad Est 11 3). See SHUSHEAN.

**SUSANCHITES**, sū-san'kits (שֻׁשַׁנְכִּיָּתִים, shūshan-khāyē'). See SHUSHANCHITES.

### SUSANNA, sū-zan'a, THE HISTORY OF:

1. Name
2. Canonicity and Position
3. Contents
4. Fact or Fiction?
5. Date
6. Original Language

This novelette has, in the LXX, the bare title "Susanna" (Σουσάννα, *Sousanna*, from Heb שֻׁשַׁנָּה, shōshannāh, "lily"). So also in the

1. **Name** Syro-Hexapla. In Cod. A (Θ) it is designated Ὁρασις α, *Hórasis a* (Vision I); see BEL AND THE DRAGON, I. In the Harklensian Syr (Ball's W<sub>2</sub>) its title is "The Book of Little [or the child?] Daniel."

Sus was with the other Additions included in the Bible Canon of the Gr, Syrian and Lat churches. Julius Africanus (c 230 AD) was the first to dispute the right of Sus to a place in the Canon, owing to its improbable character. Origen replied to him, strongly maintaining its historicity (see Schürer, *GJV*, III, 455; *HJP*, II, 3, p. 186, where the references are given). In the LXX, Syro-Hexapla and Vulg, Sus is ch 14 of Dnl, but in Θ (A B Q) it opens Dnl, preceding ch 1, a position implied in AV and RV which are based on Θ, formerly believed to be the true

LXX. Yet it is probable that even in  $\Theta$  the original place agreed with that in the true LXX (Swete's 87); so Roth (Kautzsch, *Die Apok.*, 172) and Driver (Comm. on Dnl, *Cambridge Bible*, xviii). See BEL AND THE DRAGON.

The story of Sus is thus told in  $\Theta$  (Theodotion's version), and therefore in EV which follows it.

Susanna was the beautiful and devout wife of Joakim who resided in Babylon in the early years of the exile, and owned a fine park which was open to his fellow-exiles (vs 1-4). Two of these last were elders and judges who, though held in high esteem, suffered impure thoughts toward Susanna to enter their minds. One day, meeting in the park, they divulged to each other their lustful passion toward this beautiful woman, and resolved together to seize the first opportunity to waylay her in the park and to overpower her (vs 5-15). A joint attempt was made upon Susanna, who resisted, notwithstanding threats of false accusation (vs 22-26). The elders make a false charge, both in private and in public, and she is accordingly condemned to death (vs 27-41). On the way to execution she is met by Daniel (=judge "of God") who has the case reopened, and by a system of cross-examination of the two elders succeeds in convincing the people that Susanna is innocent of the charge brought against her. She is acquitted, but her accusers are put to death.

The story told in LXX (87) is essentially the same, though varying somewhat in details. Vs 1-4 seem to have been prefixed for clearness by  $\Theta$ , for in ver 7 of LXX Susanna is introduced for the first time: "These seeing a woman of beautiful appearance called Susanna, the wife of one of the Israelites," etc. The original text began therefore with ver 5, though in a slightly different form. LXX omits vs 15-18 which tell of the two elders concealing themselves and watching as Susanna entered the park and took her bath. There is not a word in LXX concerning the threats of the elders to defame Susanna in the event of her refusing what they desired (vs 20 ff); this omission makes the LXX form of the story obscure, suggesting that this section has fallen out by error. Nor does the LXX mention the crying out of Susanna and the elders (ver 24). The trial took place in the house, according to  $\Theta$  (and EV) (ver 28), but, according to LXX, in the synagogue (ver 28). In LXX (ver 30) it is said that the number of Susanna's relatives, servants and servant-maids present at the trial was 500;  $\Theta$  is silent on this. LXX (ver 35) makes Susanna pray to God before her condemnation, but  $\Theta$  (EV, vs 42-44) after. According to LXX the young man whom the elders falsely said they found with Susanna escaped unobserved because masked;  $\Theta$  says he got away because the elders had not strength to hold him (ver 39). LXX is silent about the two maids who, according to  $\Theta$  (ver 36), accompanied Susanna to the bath.  $\Theta$  does not speak of the angel who according to LXX imparted to Daniel the wisdom he displayed (but cf  $\Theta$ , ver 50); but on the other hand he adds the words ascribed to Daniel (ver 51, EV), though he leaves out the words imputed to him by LXX (=even elders may lie). LXX omits the words of the people addressed to Daniel: "What mean these words which thou hast spoken?" (ver 47,  $\Theta$ , EV). According to  $\Theta$  (ver 50) the people entreated Daniel to act as judge among them; LXX omits this statement. Two questions were put to the elders, according to LXX: "Under what kind of tree?" "In what part of the park?" but only one, according to  $\Theta$  (and EV): "Under what kind of tree?" LXX has it that as a punishment the two elders were hurled down the precipice; according to  $\Theta$  they were slain (ver 62). In the last two verses (vs 63f) LXX points the moral of the story, but  $\Theta$  closes by describing the joy of Susanna's relatives at the happy issue of the trial and the increased respect in which Daniel came to be held. For the dependence of the VS see TEXT AND VERSIONS.

It is quite evident that the story is a fabrication and that it came to be attached to Dnl on account of the part played in it by Daniel

**4. Fact or the judge.** (1) The form of the Fiction? story differs in LXX,  $\Theta$  and the various

Syr recensions, showing that it was a floating legend, told in manifold ways. (2) No confirmation of what is here narrated has been discovered in written or epigraphic sources. (3) The grounds on which Susanna was condemned are

trivial and wholly inadequate. (4) The conduct of the judge, Daniel, is unnatural and arbitrary.

Though, however, the story is fictitious, it rests in part or wholly on older sources. (1) Ewald (*Geschichte*, IV, 386) believed that it was suggested by the Bab legend in which two old men are seduced by the goddess of love (cf Koran 2 96). (2) Brüll (*Das apokryphische Sus-Buch*, 1877), followed by Ball (*Speaker's Apoc*, II, 323-31), Marshall and R. H. Charles, came to the following conclusions: (a) That the first half of the story rests on a tradition regarding two elders (Ahab and Zedekiah) who seduced certain women by persuading them that they would thus become the mother of the Messiah. This tradition has its origin probably in Jer 29 21-23, where it is said that Jeh would sorely punish Ahab and Zedekiah because they had "committed villany in Israel," having "committed adultery with their neighbours' wives" (AV). We can trace the above story amid many variations in the writings of Origen and Jerome and in sundry rabbinical works. (b) The trial scene is believed to have a wholly different origin. It is said to have arisen about 100-96 BC, when Simon ben Shetach was president of the Sanhedrin. His son was falsely accused of a capital offence and was condemned to death. On the way to execution the accusers admitted that he was innocent of the crime; yet at his own request the son is executed in order that the father's hands might be strengthened in the inauguration of new reforms in the administration of justice. The Pharisees and Sadducees differed as to the punishment to be meted out to false witnesses where the death sentence was involved. The first party advocated a stricter examination of witnesses, and a severer penalty if their testimony could be proved false. The Sadducee party took up a more moderate position on both points. Sus has been held to be a kind of tract setting forth by example the views of the Pharisee party. If this opinion of the origin of Sus be accepted, this tract was written by a Palestinian Jew, a position rendered probable by other considerations.

If, as the Gr, Lat and Syr churches held and hold, Sus forms an integral part of Dnl, the date of this last book (see DANIEL) is the date of Sus. But there is conclusive evidence that the three "Additions" circulated independently, though we have no means of fixing the date with any certainty. Perhaps this piece arose during the struggles between the Pharisees and Sadducees about 94-89 BC; see preceding section. In that case 90 BC would be a suitable date. On the date of Theodotion's tr see DANIEL; BEL AND THE DRAGON; TEXT AND VERSIONS.

Our materials for judging of the language in which the author wrote are slender, and no great probability can at present be reached.

**6. Original Language** The following scholars argue for Gr original: Fritzsche, De Wette,

Keil, Herzfeld, Graf, Holtzmann. The following are some of the grounds: (1) There are several paronomasias or word-plays, as in vs 54 f,  $\sigma\chi\acute{\iota}\nu\omicron\nu$ , *schínon* ["under a mastick tree"] . . .  $\sigma\chi\lambda\omicron\epsilon\iota$ , *schísei* ("will cut"); vs 58 f,  $\pi\acute{\rho}\iota\nu\omicron\nu$ , *prínon* ["under a holm tree"] . . .  $\pi\acute{\rho}\iota\sigma\alpha\iota$ , *prísaí* ("to cut"). But this last word (*prísaí*) is absent from the true LXX, though it occurs in  $\Theta$  (Swete's text, ver 59, has *kataprisē* from the same root). If the word-play in vs 58 f is due to a tr based on LXX, the first example (vs 54 f), found in LXX and  $\Theta$ , is as likely to be the work of the translator of those verses from the Heb. (2) It is said that no trace of a Heb original has been discovered; but up to a few years ago the same statement could have been made of Sir.

There is a growing opinion that the author wrote in Heb (or Aram.?). so Ball, J. T. Marshall, R. H. Charles. (1) The writer was almost certainly a

Palestinian Jew, and he would be far more likely to write in his own language, esp. as he seems to have belonged to the Pharisaic party, who were ardent nationalists (see preceding section, at end). (2) There is a goodly number of Hebraisms, rather more than one would expect had the writer composed in Hellenistic Gr.

For versions and literature see BEL AND THE DRAGON; DANIEL; the Oxford Apoc, ed by R. H. Charles, 638 ff.

T. WITTON DAVIES

**SUSI**, sū'si, sōō'si (סוסי, *sūšī*): Father of Gaddi, one of the spies, who represented the tribe of Manasseh (Nu 13 11). See Gray, *HPN*, 92.

**SWADDLE**, swod'1, **SWADDLING-BAND**, swod'ling-band (vb. הָתַל, *hāthal*, "enwrap," "swaddle" [Ezk 16 4], noun הַתְּלָה, *hāthullāh*, "swaddling-band" [Job 38 9]; vb. σπαργανῶ, *sparganōō*, "to wrap in swaddling clothes" [Lk 2 7.12], noun σπάργανα, *spārgana* (pl.), "swaddling clothes" [Wisd 7 4]. AV also has "swaddle" [Lam 2 22] for תַּפְחָה, *tāphah*, lit. "to extend." But the word means "to carry on the outstretched palms of the hands" [cf. תַּפְּחִים, *tippuhim*, "dandled in the hands," Lam 2 20], whence RV's "to dandle"): "To swaddle" and "to swathe" are really the same word, both forms going back to an AS form *swethel*, "a bandage," but "swaddle" has become the technical term for the wrapping of an infant in the Orient or elsewhere. The oriental swaddling-clothes consist of a square of cloth and two or more bandages. The child is laid on the cloth diagonally and the corners are folded over the feet and body and under the head, the bandages then being tied so as to hold the cloth in position. This device forms the clothing of the child until it is about a year old, and its omission (Ezk 16 4) would be a token that the child had been abandoned. The mention of darkness as a "swaddling-band" at the birth of the sea (Job 38 9) is only a poetic way of saying that the sea, at its creation, was covered with clouds and darkness, and to find any idea of restraint involved is fanciful.

BURTON SCOTT EASTON

**SWALLOW**, swal'ō (דָּרוֹר, *d'rōr*; στρουθός, *strouthós*, in Prov and Pss, χελιδόν, *chelidōn*, in Isa; Lat *Hirundo rustica*): A small long-winged bird of

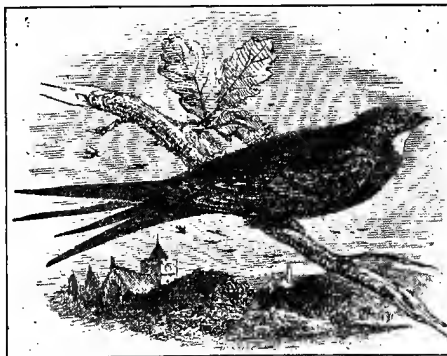

Swift (*Cypselus apus*).

exhaustless flight, belonging to the family *Hirundinidae*. *D'rōr* means the bird of freedom, and as the swallow is of tireless wing, it has been settled upon as fitting the requirements of the text. In the passages where 'āghūr is tr<sup>d</sup> "swallow," there is a mistake, that word referring to the crane. There is also a word, *sūš* or *šūš*, that means a rushing sound, that is incorrectly tr<sup>d</sup> "swallow," when it should be "swift" (*Cypselus apus*).

These birds are near relatives and so alike on the wing as to be indistinguishable to any save a close observer. Yet the Hebrews knew and made a difference. The swallow is a trifle larger and different in color. It remains all the year, while in numerous instances the swift migrates and is a regular sign of returning spring. The swallow is of long and tireless flight. The swift is so much faster that the sound of its wings can be heard when passing. The swallow plasters a mud nest under eaves, on towers, bellies, and close to human habitations. The swifts are less intimate, building in deserted places, under bridges and on rocky crevices. The swallows utter constantly a rather sweet low note; the swifts chatter harshly and incessantly at their nests. These differences are observable to the most careless people. Scientists separate the birds on account of anatomical structure also. Despite this, the birds are confused in most of our tr.

"Like a swallow or a crane, so did I chatter;  
I did moan as a dove; mine eyes fail with looking upward.  
O Lord, I am oppressed, be thou my surety" (Isa 38 14).

Here 'āghūr is tr<sup>d</sup> "swallow" and *sūš* "crane," which is clearly interchanging words, as the Arab. for "swift" is *šūš*, the same as the Heb. The line should read, "swift and crane." And another reason for changing swallow to swift, in this passage, lies in the fact that of the two birds the swift is the incessant and raucous chatterer, and this was the idea in the mind of Hezekiah when he sang his Trouble Song. Another incorrect reference is found in Jer 8 7: "Yea, the stork in the heavens knoweth her appointed times; and the turtle-dove and the swallow and the crane observe the time of their coming; but my people know not the law of Jeh." Few swallows migrate. Returning swifts are one of the first signs of spring.

"As the sparrow in her wandering, as the swallow in her flying,  
So the curse that is causeless alighteth not" (Prov 26 2).

This reference might apply to either, remembering always that the swift took its name from its exceptional flight, it being able to cover over 80 miles an hour. However, the swallow is credited with 800 miles in a night.

"Yea, the sparrow hath found her a house,  
And the swallow a nest for herself, where she may lay her young.  
Even thine altars, O Jeh of hosts,  
My King, and my God" (Ps 84 3).

Here is one instance, at least, where the swallow is at home and the tr correct. The swift might possibly have built in the temple: the swallow was sure to be there.

GENE STRATTON-PORTER

**SWAN**, swon (תִּשְׁמֶת, *tinshemeth*, "chameleon," "tree-toad," "water-hen," "owl"; κύκνος, *kúkynos*; Lat *cygnus*; AS *swan* and *swon*): Mentioned only in old VSS and RVm in Lev 11 18: "the swan, and the pelican, and the gier eagle," and in Dt 14 16 (LXX πορφυρίων, *porphuridōn*="water-hen"; Vulg *ibis*). In RV this is rightly changed to "the horned owl, and the pelican, and the vulture." A bird of the duck family wrongly placed among the abominations in old VSS of the Bible, now changed to horned owl.

White and gray swans spend their winter migratory season on the waters of the Holy Land. They are among the most ancient birds of history; always have been used for food; when young and tender, of fine flesh and delicious flavor; so there is no possibility that they were ever rightfully placed among the birds unsuitable for food. Their feeding habits are aquatic, their food in no way objectionable.

GENE STRATTON-PORTER

**SWEARING**, swā'ring. See OATH; PERJURY; CRIMES; PUNISHMENTS.

**SWEAT**, swet (זֵיעָה, *zē'ah* [Gen 3 19], זֵיעָה, *yeza'* [Ezk 44 18]; ἵδρωσ, *hidrōs* [2 Macc 2 26; Lk 22 44]): "In the sweat of thy face shalt thou eat bread" (Gen 3 19). Somewhat difficult is the



passage, which RV renders: "But the priests the Levites, the sons of Zadok . . . shall have linen ties upon their heads, and shall have linen breeches upon their loins; they shall not gird themselves with anything that causeth sweat," lit. "they shall not gird themselves with sweat" (Ezk 44 15.18). The idea is evidently that profuse perspiration would make their ministrations unpleasant. The rule was of special importance in the sultry climate of Pal.

Luke, the physician, describing the agony of the Lord in Gethsemane, says: "His sweat became as it were great drops (*θρόμβοι, thrómboi*) of blood falling down upon the ground" (Lk 22 44, RV, following N<sup>a</sup> A B, etc, notes in m: "Many ancient authorities omit vs 43.44"). There are two difficulties of interpretation in this passage, apart from the difficulty which the physiological explanation of the phenomenon presents: (1) the word (*θρόμβος, thrómbos*) tr<sup>d</sup> "drop" means lit. "a clot of blood," "a lump," "a curd," and is nowhere else used in the sense of drop. (2) It has been generally accepted that the sweat of the brow of Jesus had become bloody in appearance and in character, a symptom called in ancient medicine *αἱματώδης ἰδρῶς, haimatódēs hidrós*, "bloody sweat." It must, however, be observed that this tr would make the Gr particle *ὡσεὶ, hōseti*, superfluous, by which, not the identity of the sweat with drops of blood, but a certain similarity or comparison must be intended. Ch. Th. Kuinoel, in his Lat comm. on the historical books of the NT (Leipzig, 1809, II, 654), has given all known parallel instances in history and legend, which seem to prove that under certain psychological or physiological conditions, though rarely, *haimatódēs hidrós* has occurred.

Olshausen in his *Comm.*, II, 469, thinks that the following points of comparison might have been in the mind of Luke: (1) the sweat may have appeared on the forehead of Jesus in heavy drops; (2) these may have dropped visibly to the ground, just as drops of blood fall from a wound; (3) in addition, possibly a reddish color may have been noticeable, owing to an exudation of the arteries, though the latter is not directly expressed in the words of the evangelist. See also Dr. Stroud, *On the Physical Cause of the Death of Christ*, 183; Bynaesus, *De morte Christi*, II, 33.

The people of Pal in Gr-Rom times were generally provided with handkerchiefs, used esp. to wipe off the perspiration. The fashion was derived from Rome, whence the name of these napkins became *σουδάριον, soudáron*, Lat *sudarium*. The late legend of St. Berenice or St. Veronica, who presented her handkerchief to the Saviour on His way to be crucified, and who found, when it had been returned to her by the Lord, that His features had been imprinted upon the cloth, is a reminiscence of this use. These handkerchiefs were frequently used to tie up small bundles of certain possessions, money, etc (Lk 19 20). As a rule the dead had their faces covered with one, or had it tied around the head (Jn 11 44; 20 7). In Ephesus the handkerchiefs of St. Paul were carried to the sick, and achieved miraculous cures (Acts 19 12).

The vb. *ἰδρῶ, hidróō*, "to sweat," is found in a rather difficult passage of the *Didache* (1.6), which is introduced as a quotation, the source of which, however, we do not know: "Let thy alms sweat into [in?] thy hands, until thou knowest to whom thou givest." The context seems to show that we have here a free repetition of the arguments of Sir 12 1 ff, so that the meaning would be: "In giving charity, do not give indiscriminately or thoughtlessly, but consider carefully so that no one who is unworthy receive your benefaction." Still it is not impossible that the text is corrupt in the passage.

H. L. E. LUERING

**SWEET CANE**, swēt kân. See REED.

**SWEET INCENSE**. See SPICES.

**SWELL**, swel (*צָבְחָה, çābhāh*): In the ordeal of the Water of Jealousy described in Nu 5 11-31 (P), the effect on the unfaithful wife of the drinking of the holy water was to cause the thigh to fall away (RV) or rot (AV) and the abdomen to "swell."

This ceremonial was a direct appeal to the judgment of God, for there was nothing in the holy water (taken from the laver) or the dust of the temple which was mixed with it to produce this effect. In the Talmudic tract *Šōtāh* there are given many rabbinical opinions and particulars as to the procedure in later times. Apparently from the passage in Nu, the judgment speedily followed the appeal, but according to *Šōtāh*, iii.4, it might be postponed even for four years, and in v.1, it is said to have produced the same effect on the adulterer as on the unfaithful wife. We have no details as to the nature or permanency of the swelling.

"Swell" as the tr of another word, *bāçēk*, is used in the sense of blistering of the feet from long tramping. Both in Dt 8 4 and Neh 9 21 it is said that in spite of their long wilderness marches the feet of the Israelites did not swell. This was a token of Divine protection. See SWOLLEN.

ALEX. MACALISTER

**SWELLING**, swel'ing: The vb. *גָּאָה, gā'āh*, means "rise up" (Ezk 47 5, etc), so that the noun *gā'āwāh* (Ps 46 3) means "arising." The "swelling" of the sea that shakes the mountains is a perfectly good tr, and "pride" (so ARVm) is beside the mark. In Jer 12 5; 49 19 || 50 44; Zec 11 3 is found the phrase *g'ōn ha-yardēn*, "exaltation of the Jordan," which AV translates "pride of Jordan" in Zec and "swelling of Jordan" in Jer (RV has "pride" throughout, with "swelling" in m of Jer). What is described is a place, with a mass of vegetation, easily burned (Zec 11 1-3), a lair of lions (Jer 49 19; Zec 11 3), and a particularly dangerous place for human beings (Jer 12 5). The luxuriant thicket of the Jordan bank is evidently meant, which could well be spoken of as "Jordan's pride" (*OHL*, "majesty of the Jordan"), and "swelling" is quite impossible.

In the NT "swelling" is used in 2 Cor 12 20 for *φυσίωσις, phusiósis*, "puffing up," "blatant self-conceit," and 2 Pet 2 18 || Jude ver 16 for *ὑπερόγκος, huperógkos*, "overgrown," "solemnly inane."

BURTON SCOTT EASTON

**SWIFT**. See SWALLOW.

**SWIFT BEASTS** (*קִרְקָרוֹת, kirkārōth* [Isa 66 20]): AV and ERV "swift beasts," ERVm and ARV "dromedaries." In Mic 1 13 (*רֶכֶשֶׁת, rekheset*) a horse is meant, RV "swift steed." See CAMEL; HORSE.

**SWINE**, swin (*חֲזִיר, ḥāzīr*; cf Arab. *خنزير, khinzīr*; vs, *hūs*, LXX and NT; cf Gr *σῦς, sūs*, and Lat *sūs*; adj. *ἕγιος, hūgios*, as subst., LXX; *χοίρος, chōiros*, LXX and NT): In both ancient and modern times domestic swine have been little kept in Pal, but wild swine are well known as inhabitants of the thickets of the *Hāleh*, the Jordan valley, the Dead Sea, and some of the mountains. The species is *Sus scrofa*, the wild pig of Europe, North Africa and Western Asia.

In the OT the swine is mentioned in Lev 11 7 and Dt 14 8 as an unclean animal: "And the swine, because he parteth the hoof, and is clovenfooted, but cheweth not the cud, he is unclean unto you." In Isa 65 4 and 66 3.17 the eating of swine's flesh and the offering of oblations of swine's blood are referred to as abominations. LXX also refers to swine in three passages where these animals are not mentioned in the Heb and EV. In 2 S 17 8 where EV has "as a bear robbed of her whelps in the field," LXX adds (tr) "and as a savage boar in the plain." In 1 K 21 19 (LXX 20 19), where EV

has "in the place where dogs licked the blood of Naboth," LXX has "where the swine and the dogs licked"; similarly in 1 K 22 38. In 1 Macc 1 47 there is reference to a decree of Antiochus ordering the sacrifice of swine. In 2 Macc 6 and 7 there are accounts of the torture and death of Eleazar, an aged scribe, and of a mother and her seven sons for refusing to taste swine's flesh. Swine, the property of Gentiles, are mentioned in the account of the Gadarene demoniac (Mt 8 30.31.32; Mk 5 11.12.13.14.16; Lk 8 32.33), and in the parable of the Prodigal Son (Lk 15 15.16).

**Figurative:** We find the following figurative references to swine:

- "The boar out of the wood doth ravage it,  
And the wild beasts of the field feed on it" (i.e. on the "vine out of Egypt") (Ps 80 13);
- "As a ring of gold in a swine's snout,  
So is a fair woman that is without discretion" (Prov 11 22);
- "The Carmonians [AV Carmanians, perhaps of Kirman or Carmania, in Southwestern Persia] raging in wrath shall go forth as the wild boars of the wood" (2 Esd 15 30);
- "The dog turning to his own vomit again, and the sow that had washed to wallowing in the mire" (2 Pet 2 22; cf Prov 26 11).

ALFRED ELY DAY

**SWOLLEN**, swōl'n (πυμρασθαί, *pimprasthai*, only in Acts 28 6): The Melitans expected to see Paul poisoned by the viper's bite. RV and AV translate it "swollen," but the word is used by certain medical writers in the sense of inflammation; see Nicander, *Theriaca*, 306; Hesiod, *Theogonia*, 856, expressing thereby the burning up by a thunderbolt. Swelling accompanies the local lesion of snake-bite and often large purpuric exudation of blood, as well as paralysis, esp. of the lower limbs.

**SWORD**, sōrd. See ARMOR, III, 5.

**SYCAMINE**, sik'a-mīn, **TREE** (συκάμινος, *sukáminos* [Lk 17 6]): This is generally accepted as the black mulberry tree (*Morus nigra*; N.O.



Sycamine or Black Mulberry.

*Urticaceae*), known in Arab. as *tāl shāmī*, "the Damascus mulberry," a fine tree which grows to the height of 30 ft. It produces the dark blood-red mulberry juice referred to in 1 Macc 6 34 (*μόρον, mōron*), "the blood of . . . mulberries," which was shown to the elephants of the Syrians. The white

mulberry, *M. alba*, has white and less juicy fruit, and it is cultivated largely for the sake of its leaves with which the silkworms of the Lebanon are fed.

E. W. G. MASTERMAN

**SYCAMORE**, sik'a-mōr. See SYCOMORE.

**SYCHAR**, sī'kār (Συχάρ, *Suchár*): Mentioned only once, in connection with the visit of Jesus to Jacob's Well (Jn 4 5). He was passing through



Fountain at 'Askar.

Samaria on His way to Galilee, "so he cometh to a city of Samaria, called Sychar, near to the parcel of ground that Jacob gave to his son Joseph: and Jacob's well was there." Jerome thought the name was a clerical error for Sychem (*Ep.* 86). In *Onom* he is content to translate Eusebius, placing Sychar E. of Neapolis. It is now generally admitted that the text is correct. Some have held, however, that Sychar is only another name for Shechem ("Sychem"). It is suggested, e.g., that it is a nickname applied in contempt by the Jews, being either *shikkōr*, "drunken," or *sheker*, "falsehood." Others think the form has arisen through change of *m* to *r* in pronunciation; as *l* to *r* in Beliar. These theories may safely be set aside. The evidence that Sychar was a distinct place E. of Shechem may be described as overwhelming. It is carefully and perspicuously marshaled by G. A. Smith (*HGHL*, 367 ff). The manner in which it is mentioned shows that it was not a specially well-known place: "a city of Samaria called Sychar." No one familiar with Pal would have written "a city of Samaria called Sychem." It is mentioned only because of its nearness to the well.

As to the position of the well, there is general agreement (see JACOB'S WELL). It is on the right of the road where it bends from the plain of *Makhneh* into the pass of Shechem. Fully half a mile off, on the edge of the plain, is the village of 'Askar, on the lower slope of Ebal. A little to the W. is the

traditional tomb of Joseph. This is the district E. of Shechem usually identified with Jacob's "parcel of ground." Many have sought to find Sychar in the modern 'Askar. There are two difficulties. The first is the initial letter 'ain in the modern name. But G. A. Smith has shown that such a change as this, although unusual, is not impossible. The second is the presence of the copious spring, 'Ain 'Askar, which would make it unnecessary for the villagers to carry water from Jacob's Well. This cannot easily be explained away. One could understand a special journey at times, if any peculiar value attached to the water in the well; but from it, evidently, the woman drew her ordinary supplies (ver 15). This difficulty would probably in any case be fatal to the claim of the village at 'Ain 'Askar to represent the ancient Sychar. But Professor R. S. A. Macalister has shown reason to believe that the village is not older than Arab times (PEFS, 1907, 92 ff). He examined the mound *Telul Balāta*, nearly  $\frac{1}{2}$  mile S.W. of 'Askar, and just W. of Joseph's tomb. There he found evidence of occupation from the days of the Heb monarchy down to the time of Christ. Here there is no spring; and it is only  $\frac{1}{4}$  mile distant from Jacob's Well—nearer therefore to the well than to 'Askar. In other respects the site is suitable, so that perhaps here we may locate the Sychar of the Gospel. The name may easily have migrated to 'Askar when the village fell into decay. W. EWING

**SYCHEM**, si'kem (Συχέμ, *Suchém*): In this form the name of Shechem appears in Acts 7 16 AV, in the report of Stephen's speech. AV is a transcription from the Gr; RV in accordance with its practice, to give uniformity in the Eng., follows the Heb form of the name given in the OT.

**SYCOMORE**, sik'ō-mōr, TREE (שִׁקְמוֹרָה, *shikmāh*, Aram. שִׁקְמָא, *shikmā'*, pl. שִׁקְמִים, *shikmīm*; in LXX wrongly tr<sup>d</sup> by συκάμινος, *sukáminos*, "the mulberry"; see SYCAMINE [1 K 10 27; 1 Ch 27 28; 2 Ch 1 15; 9 27; Isa 9 10; Am 7 14]; שִׁקְמוֹת, *shikmōth* [Ps 78 47]; συκομοῦρα, *sukomōraia* [Lk 19 4]): The sycamore-fig, *Ficus sycomorus* (N.O. *Urticaceae*), known in Arab. as *Jummeiz*, is one of the finest of the lowland trees of Pal, and attains still greater proportions in Lower Egypt. It is evident from 1 K 10 27; 2 Ch 1 15 that it was once abundant, and at a later period it was so plentiful in the neighborhood of what is now *Haiifa* as to give the name Sykaminon to the town which once stood near there. It is a tree which cannot flourish in the cooler mountain heights; it cannot stand frost (Ps 78 47). It was one of the distinguishing marks of Lower, as contrasted with Upper, Galilee that the sycamore could flourish there. It is highly improbable that sycomores could ever have flourished near Tekoa (cf Am 7 14), but it is quite possible that the town or individual inhabitants may have held lands in the Jordan valley or in the Shephelah on which these trees grew. Villages in Pal today not infrequently possess estates at considerable distances; the village of *Silwān* (Siloam), for example, possesses and cultivates extensive fertile lands halfway to the Dead Sea. The sycamore produces small, rounded figs, about an inch long, which grow upon tortuous, leafless twigs springing from the trunk or the older branches; they are more or less tasteless. It would appear that in ancient times some treatment was adopted, such as piercing the apex of the fruit to hasten the ripening. Amos was a "nipper" (בֹּלֵס, *bōlēṣ*) of sycamore figs (Am 7 14). The tree not uncommonly attains a height of 50 ft., with an enormous trunk; in many parts, esp. where, as near the coast,

the tree grows out of sandy soil, the branching roots stand out of the ground for some distance. The timber is of fair quality and was much valued in ancient times (1 K 10 27; 2 Ch 1 15; 9 27; Isa 9 10). Mummy cases and many of the best preserved wooden utensils of ancient Egypt life

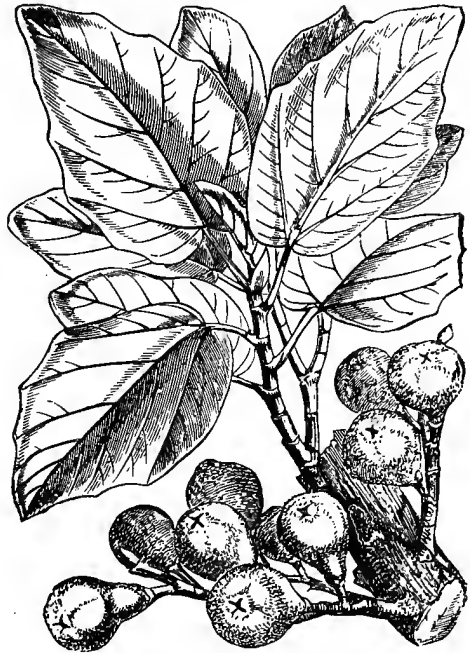

Sycamore (*Ficus sycomorus*).

are made of it. This tree must be distinguished from the Eng. sycamore, *Acer pseudo-platanus* (N.O. *Spindaceae*), the "false plane tree," a kind of maple. E. W. G. MASTERMAN

**SYENE**, si-ē'nē. See SEVENEH.

**SYMEON**, sim'ē-on (Συμεών, *Symeōn*): RV in Lk 3 30; Acts 13 1; 15 14 for AV "Simeon" (q.v.). The persons are:

- (1) An ancestor of Jesus (Lk 3 30).
- (2) Symeon, called Niger, one of the prophets and teachers in the church at Antioch (Acts 13 1).
- (3) For Simon Peter, see PETER; cf Acts 15 14. See SIMEON, (4), (5), (6).

**SYNAGOGUE**, sin'a-gog:

1. Name
2. Origin
3. Spread of Synagogues
4. The Building
  - (1) The Site
  - (2) The Structure
  - (3) The Furniture
5. The Officials
  - (1) The Elders
  - (2) The Ruler
  - (3) The Servant (or Servants)
  - (4) Delegate of the Congregation
  - (5) The Interpreter
  - (6) The Almoners
6. The Service
  - (1) Recitation of the *sh'ma'*
  - (2) Prayers
  - (3) Reading of the Law and the Prophets
  - (4) The Sermon
  - (5) The Benediction

LITERATURE

Synagogue, Gr συναγωγή, *sunagōgē*, "gathering" (Acts 13 43), "gathering-place" (Lk 7 5), was the name applied to the Jewish place of worship

in later Judaism in and outside of Pal. *Proseuchē*, "a place of prayer" (Acts 16 13), was probably more of the nature of an inclosure,

**1. Name** marking off the sacred spot from the profane foot, than of a roofed building like a synagogue. *Sabbateton* in *Ant*, XV, i, 6, 2, most probably also meant synagogue. In the Mish we find for synagogue *bēth ha-k'neseth*, in the Tgs and Talm *bē-kh'nīshā'*, or simply *k'nīshā'*. The oldest Christian meetings and meeting-places were modeled on the pattern of the synagogues, and in Christian-Palestinian Aram. the word *k'nīshā'* is used for the Christian church (cf Zahn, *Tatian's Diatessaron*, 335).

That the synagogue was, in the time of Our Lord, one of the most important religious institutions of the Jews is clear from the fact that

**2. Origin** it was thought to have been instituted by Moses (*CAP*, ii, 17; Philo, *De Vita Moses*, iii.27; cf Tg Jer to Ex 18 20). It must have come into being during the Bab exile. At that time the more devout Jews, far from their native land, having no sanctuary or altar, no doubt felt drawn from time to time, esp. on Sabbath and feast days, to gather round those who were specially pious and God-fearing, in order to listen to the word of God and engage in some kind of worship. That such meetings were not uncommon is made probable by Ezk 14 1; 20 1. This would furnish a basis for the institution of the synagogue. After the exile the synagogue remained and even developed as a counterpoise to the absolute sacerdotalism of the temple, and must have been felt absolutely necessary for the Jews of the Dispersion. Though at first it was meant only for the exposition of the Law, it was natural that in the course of time prayers and preaching should be added to the service. Thus these meetings, which at first were only held on Sabbaths and feast days, came also to be held on other days, and at the same hours with the services in the temple. The essential aim, however, of the synagogue was not prayer, but instruction in the Law for all classes of the people. Philo calls the synagogues "houses of instruction, where the philosophy of the fathers and all manner of virtues were taught" (cf Mt 4 23; Mk 1 21; 6 2; Lk 4 15.33; 6 6; 13 10; Jn 6 59; 18 20; *CAP*, ii, 17).

In Pal the synagogues were scattered all over the country, all the larger towns having one or more (e.g. Nazareth, Mt 13 54; Capernaum,

**3. Spread** Mt 12 9). In Jerus, in spite of the fact that the Temple was there, there were many synagogues, and all parts of the Diaspora were represented by particular synagogues (Acts 6 9). Also in heathen lands, wherever there was a certain number of Jews, they had their own synagogue: e.g. Damascus (Acts 9 2), Salamis (13 5), Antioch of Pisidia (13 14), Thessalonica (17 1), Corinth (18 4), Alexandria (Philo, *Leg Ad Cai*, xx), Rome (ib, xxiii). The papyrus finds of recent years contain many references to Jewish synagogues in Egypt, from the time of Euergetes (247-221 BC) onward. According to Philo (*Quod omnis probus liber sit*, xii, et al.) the Essenes had their own synagogues, and, from 'Ābhōth 3 10, it seems that "the people of the land," i.e. the masses, esp. in the country, who were far removed from the influence of the scribes, and were even opposed to their narrow interpretation of the Law, had their own synagogues.

(1) *The site*.—There is no evidence that in Pal the synagogues were always required to be built upon high ground, or at least that they should overlook all other houses (cf *PEFS*, July, 1878, 126), though we read in the Talm that this was one of the requirements (*Tōš M'ghillāh*, ed Zunz, 4 227;

*Shabbāth* 11a). From Acts 16 13 it does not follow that synagogues were intentionally built outside the city, and near water

**4. The Building** for the sake of ceremonial washing (cf *Monatsschr. für Gesch. und Wissenschaft. des Judenthums*, 1889, 167-70; *HJP*, II, 370).

(2) *The structure*.—Of the style of the architecture we have no positive records. From the description in the Talm of the synagogue at Alexandria (*Tōš Šukkāh*, ed Zunz, 198 20; *Šukkāh* 51b) one imagines the synagogues to have been modeled on the pattern of the temple or of the temple court. From the excavations in Pal we find that in the building the stone of the country was used. On the lintels of the doors were different forms of ornamentation, e.g. seven-branched candlesticks, an open flower between two paschal lambs, or vine leaves with bunches of grapes, or, as in Capernaum, a pot of manna between two representations of Aaron's rod. The inside plan "is generally that of two double colonnades, which seem to have formed the body of the synagogue, the aisles E. and W. being probably used as passages. The intercolumnar distance is very small, never greater than 9½ ft." (Edersheim). Because of a certain adaptation of the corner columns at the northern end, Edersheim supposes that a woman's gallery was once erected there. It does not appear, however, from the OT or NT or the oldest Jewish tradition that there was any special gallery for women. It should be noted, as against this conclusion, that in *De Vita Contemplativa*, attributed by some to Philo, a certain passage (sec. iii) seems to imply the existence of such a gallery.

(3) *The furniture*.—We only know that there was a movable ark in which the rolls of the Law and the Prophets were kept. It was called 'ārōn ha-kōdhesh, but chiefly *tēbhāh* (*M'ghillāh* 3 1; *N'dhārīm* 5 5; *Ta'ānūth* 2 1.2), and it stood facing the entrance. According to *Ta'ānūth* 15a it was taken out and carried in a procession on fast days. In front of the ark, and facing the congregation, were the "chief seats" (see CHIEF SEATS) for the rulers of the synagogue and the learned men (Mt 23 6). From Neh 8 4 and 9 4 it appears that the *bēmah* (Jerus *M'ghillāh* 3 1), a platform from which the Law was read, although it is not mentioned in the NT, was of ancient date, and in use in the time of Christ.

(1) *The elders*.—These officials (Lk 7 3) formed the local tribunal, and in purely Jewish localities acted as a Committee of Management

**5. The Officials** of the affairs of the synagogue (cf *B'rākhōth* 4 7; *N'dhārīm* 5 5; *M'ghillāh* 3 1). To them belonged, most probably, among other things, the power to excommunicate (cf Ezr 10 8; Lk 6 22; Jn 9 22; 12 42; 16 2; 'Ēdhuyōth 5 6; *Ta'ānūth* 3 8; *Middōth* 2 2).

(2) *The ruler*.—Gr *archisynāgōgos* (Mk 5 35; Lk 8 41.49; 13 14; Acts 13 8.17), Heb *rō'sh ha-k'neseth* (*Šōtāh* 7 7.8). In some synagogues there were several rulers (Mk 5 22; Acts 13 15). They were most probably chosen from among the elders. It was the ruler's business to control the synagogue services, as for instance to decide who was to be called upon to read from the Law and the Prophets (*Yōmā'* 7 1) and to preach (Acts 13 15; cf Lk 13 14); he had to look after the discussions, and generally to keep order.

(3) *The servant (or servants)*.—Gr *hupērētēs*; Talm *hazzān* (Lk 4 20; *Yōmā'* 7 1; *Šōtāh* 7 7.8). He had to see to the lighting of the synagogue and to keep the building clean. He it was who wielded the scourge when punishment had to be meted out to anyone in the synagogue (Mt 10 17; 23 34; Mk 13 9; Acts 22 19; cf *Makkōth* 16). From *Shabbāth* 1 3 it seems that the *hazzān* was also an elementary teacher (see EDUCATION).



CHORAZIN—RUIN OF JEWISH SYNAGOGUE. ONLY RUIN EXTANT



(4) *The delegate of the congregation.*—Heb *sh'lv'h çbbûr* (*Rô'sh ha-shânâh* 4 9; *B'râkhôth* 5 5). This office was not permanent, but one was chosen at each meeting by the ruler to fill it, and he conducted the prayers. According to *M'ghillâh* 4 5, he who was asked to read the Scriptures was also expected to read the prayers. He had to be a man of good character.

(5) *The interpreter.*—Heb *m'thōrg'mân*. It was his duty to translate into Aram. the passages of the Law and the Prophets which were read in Heb (*M'ghillâh* 3 3; cf 1 Cor 14 28). This also was probably not a permanent office, but was filled at each meeting by one chosen by the ruler.

(6) *The almoners.*—(*D'mā'î* 3 1; *Kiddûshîn* 4 5). Alms for the poor were collected in the synagogue (cf Mt 6 2). According to *P'êâh* 8 7, the collecting was to be done by at least two persons, and the distributing by at least three.

(1) *The recitation of the "sh'ma'."*—At least ten persons had to be present for regular worship (*M'ghillâh* 4 3; *Sanhedhrîn* 1 6). There were special services on Saturdays and feast days. In order to keep the synagogue services uniform with those of the temple, both were held at the same hours. The order of service was as follows: the recitation of the *sh'ma'*, i.e. a confession of God's unity, consisting of the passages Dt 6 4-9; 11 13-21; Nu 15 37-41 (*B'râkhôth* 2 2; *Tâmûdh* 5 1). Before and after the recitation of these passages "blessings" were said in connection with the passages (*B'râkhôth* 1 4). This formed a very important part of the liturgy. It was believed to have been ordered by Moses (cf *Ant*, IV, viii, 13).

(2) *Prayers.*—The most important prayers were the *Sh'mōneh 'esrêh*, "Eighteen Eulogies," a cycle of eighteen prayers, also called "The Prayer" (*B'râkhôth* 4 3; *Ta'ânûth* 2 2). Like the *sh'ma'* they are very old.

The following is the first of the eighteen: "Blessed art Thou, the Lord our God, and the God of our fathers, the God of Abraham, the God of Isaac, and the God of Jacob: the great, the mighty and the terrible God, the most high God, Who showest mercy and kindness, Who createst all things, Who rememberest the pious deeds of the patriarchs, and wilt in love bring a redeemer to their children's children for Thy Name's sake; O King, Helper, Saviour and Shield! Blessed art Thou, O Lord, the Shield of Abraham."

The prayers of the delegate were met with a response of Amen from the congregation.

(3) *The reading of the Law and the Prophets.*—After prayers the *pârâshâh*, i.e. the pericope from the Law for that Sabbath, was read, and the interpreter tr<sup>d</sup> verse by verse into Aram. (*M'ghillâh* 3 3). The whole Pent was divided into 154 pericopes, so that in the course of 3 years it was read through in order. After the reading of the Law came the *Haphtârâh*, the pericope from the Prophets for that Sabbath, which the interpreter did not necessarily translate verse by verse, but in paragraphs of 3 verses (*M'ghillâh*, loc. cit.).

(4) *The sermon.*—After the reading from the Law and the Prophets followed the sermon, which was originally a casuistical exposition of the Law, but which in process of time assumed a more devotional character. Anyone in the congregation might be asked by the ruler to preach, or might ask the ruler for permission to preach.

The following example of an old (1st cent. AD) rabbinic sermon, based on the words, "He hath clothed me with the garments of salvation" (Isa 61 10, a verse in the chapter from which Jesus took His text when addressing the synagogue of Nazareth), will serve as an illustration of contemporary Jewish preaching:

"Seven garments the Holy One—blessed be He!—has put on, and will put on from the time the world was created until the hour when He will punish the wicked Edom (i.e. Rom empire). When He created the world,

He clothed Himself in honor and majesty, as it is said (Ps 104 1): 'Thou art clothed in honor and majesty.' Whenever He forgave the sins of Israel, He clothed Himself in white, for we read (Dnl 7 9): 'His raiment was white as snow.' When He punishes the peoples of the world, He puts on the garments of vengeance, as it is said (Isa 59 17): 'He put on garments of vengeance for clothing, and was clad with zeal as a cloke.' The sixth garment He will put on when the Messiah comes; then He will clothe Himself in a garment of righteousness, for it is said (Isa 61 10): 'He put on righteousness, as a breast-plate, and an helmet of salvation upon His head.' The seventh garment He will put on when He punishes Edom; then He will clothe Himself in 'adhôm, i.e. 'red,' for it is said (Isa 63 2): 'Wherefore art Thou red in Thine apparel?' But the garment which He will put upon the Messiah, this will shine afar, from one end of the earth to the other, for it is said (Isa 61 10): 'As a bridegroom decketh himself with a garland.' And the Israelites will partake of His light, and will say: 'Blessed is the hour when the Messiah shall come! Blessed the womb out of which He shall come! Blessed His contemporaries who are eye-witnesses! Blessed the eye that is honored with a sight of Him! For the opening of His lips is blessing and peace; His speech is a moving of the spirits; The thoughts of His heart are confidence and cheerfulness; The speech of His tongue is pardon and forgiveness; His prayer is the sweet incense of offerings; His petitions are holiness and purity. O how blessed is Israel, for whom such has been prepared! For it is said (Ps 31 19): 'How great is Thy goodness, which thou hast laid up for them that fear thee!'" (*Pesikktâ*, ed Buber).

(5) *The benediction.*—After the sermon the benediction was pronounced (by a priest), and the congregation answered Amen (*B'râkhôth* 5 4; *Shôth* 7 2.3).

LITERATURE.—L. ZUNZ, *Die gottesdienstlichen Vorträge der Juden*, 2d ed; Herzfeld, *Geschichte des Volkes Israel*, III, 129-37, 183-226; Hausrath, *Neutestamentliche Zeitgesch.*, 2d ed, 73-80; HJP, II, 357-86; GJV<sup>4</sup>, II, 497-544; Edersheim, *Life and Times of Jesus the Messiah*, 5th ed, I, 431-50; Oesterly and Box, "The Religion and Worship of the Synagogue," *Church and Synagogue*, IX, no. 2, April, 1907, p. 46; W. Bacher, art. "Synagogue" in *HDB*; Strack, art. "Synagogen," in *RE*, 3d ed, XIX.

PAUL LEVERTOFF

SYNAGOGUE OF LIBERTINES. See LIBERTINES.

SYNAGOGUE OF SATAN. See SATAN, SYNAGOGUE OF.

SYNAGOGUE, THE GREAT: A college or assembly of learned men, originating with Ezra, to whom Jewish tradition assigns an important share in the formation of the OT Canon, and many legal enactments (see CANON OF THE OT). One of its latest members is said to have been Simon the Just (c 200 BC). The oldest notice of the Great Synagogue is in the tract of the Mish, *Pirḳê 'Ābhôth* (c 200 AD); this is supplemented by an often-quoted passage in another tract of the Mish, *Bābhâ' Bathrâ'* (14b), on the Canon, and by later traditions. It tells against the reliableness of these traditions that they are late, and are mixed up with much that is self-evidently unhistorical, while no corroboration is found in *Ezr* or *Neh*, in the *Apoc*, or in *Jos*. On this account, since the exhaustive discussion by Kuenen on the subject (*Over de Mannen der Groote Synagoge*), most scholars have been disposed to throw over the tradition altogether, regarding it as a distorted remembrance of the great convocation described in *Neh* 8-10 (so W. R. Smith, *Driver*, etc; cf art. by Selbie in *HDB* in support of total rejection). This probably is an excess of skepticism. The convocation in *Neh* has no points of resemblance to the kind of assembly recalled in this tradition; and while fantastic details may be unreal, it is difficult to believe that declarations so circumstantial and definite have no foundation at all in actual history. The direct connection with Ezra may be discounted, though possibly—indeed it is likely—somebody associated with Ezra in his un-

deniable labors on the Canon may have furnished the germ from which the institution in question was developed (see the careful discussion in C. H. H. Wright, *Eocl.*, 1-10, and Excursus III, "The Men of the Great Synagogue").

For the rabbinical quotations and further important details, see C. Taylor's *Sayings of the Jewish Fathers*, 11 f and 110 f.

JAMES ORR

**SYNOPTIC**, si-nop'tik, **GOSPELS**. See **GOSPELS**, **SYNOPTIC**.

**SYNTYCHE**, sin'ti-kē (Συντύχη, *Suntýchē*, lit. "fortunate" [Phil 4 2]): A Christian woman in the church at Philippi. She and Euodia, who had some quarrel or cause of difference between them, are mentioned by name by Paul, and are besought separately: "I beseech Euodia, and I beseech Syntyche" (AV) to be reconciled to one another, to be "of the same mind in the Lord." The apostle also entertains an unnamed Christian at Philippi, whom he terms "true yokefellow," to "help these women, for they labored with me in the gospel." What he means is that he asks the true yokefellow to help Euodia and Syntyche, each of whom had labored with Paul.

This refers to the visit which he, in company with Silas and Luke and Timothy, paid to Philippi (Acts 16 12 ff), and which resulted in the gospel being introduced to that city and the church being formed there. Euodia and Syntyche had been among the first converts and had proved helpful in carrying on the work. The word used for "labored," signifies "they joined with me in my struggle," and probably refers to something more than ordinary labor, for those were critical times of danger and suffering, which the apostle and his companions and fellow-workers then encountered at Philippi.

That workers so enthusiastic and so honored should have quarreled, was very sad. Paul, therefore, entertains them to be reconciled. Doubtless his request was given heed to, esp. in view of his promised visit to Philippi. See **EUODIA**; **YOKEFELLOW**.

JOHN RUTHERFURD

**SYNZYGUS**, sin'zi-gus (σύνζυγος, *súnzyge*): In Phil 4 3 it is rendered "yokefellow." WHm (Σύνζυγε, *Súnzyge*), Thayer, *Lex. NT*, 594 (Σύζυγε, *Súzyge*), and others, take it as a proper name in this passage. See **YOKEFELLOW**.

**SYRACUSE**, sir'a-kūs, sir-a-kūs' (Συράκουσαι, *Surákousai*; Lat *Syracusae*, Ital. *Siracusa*): Situated on the east coast of Sicily, about midway between Catania and the southeastern extremity of the island.

The design of the present work scarcely permits more than a passing allusion to Syracuse, the most brilliant Gr colony on the shores of the Western Mediterranean, where Paul halted three days, on his way from Melita to Rome (Acts 28 12). The original Corinthian colony founded in 734 BC (Thucydides vi.3) was confined to the islet Ortygia, which separates the Great Harbor from the sea. Later the city spread over the promontory lying northward of Ortygia and the harbor.

Syracuse assumed a preëminent position in the affairs of Sicily under the rule of the tyrants Gelon (485-478 BC; cf Herodotus vii.154-55) and Hieron (478-467 BC). It flourished greatly after the establishment of popular government in 466 BC (Diodorus xi.68-72). The Syracusans successfully withstood the famous siege by the Athenians in 414 BC, the narrative of which is the most thrilling part of the work of Thucydides (vi, vii).

Dionysius took advantage of the fear inspired by the Carthaginians to elevate himself to despotic power in 405 BC, and he was followed, after a reign of 38 years, by his son of the same name. Although democratic government was restored by Timoleon

after a period of civil dissensions in 344 BC (Plutarch, *Timoleon*), popular rule was not of long duration.

The most famous of the later rulers was the wise Hieron (275-216 BC), who was the steady ally of the Romans. His grandson and successor Hieronymus deserted the alliance of Rome for that of Carthage, which led to the celebrated siege of the city by the Romans under Marcellus and its fall in 212 (Livy xxiv.21-33). Henceforth Syracuse was the capital of the Rom province of Sicily. Cicero calls it "the greatest of Greek cities and the most beautiful of all cities" (Cicero *Verr.* iv.52).

GEORGE H. ALLEN

**SYRIA**, sir'i-a (Συρία, *Suria* [Mt 4 24; Lk 2 2]):

1. Name and Its Origin
2. Other Designations
3. Physical
  - (1) The Maritime Plain
  - (2) First Mountain Belt
  - (3) Second Mountain Belt
  - (4) Great Central Valley
  - (5) The Eastern Belt
  - (6) Rivers
  - (7) Nature of Soil
  - (8) Flora
  - (9) Fauna
  - (10) Minerals
  - (11) Central Position
4. History
  - (1) Canaanitic Semites
  - (2) Sargon of Agade
  - (3) Babylonian Supremacy
  - (4) Hittite and Aramaean
  - (5) Hittites and Egyptians
  - (6) Amarna Period
  - (7) Ramesses II
  - (8) Philistines
  - (9) Tiglath-pileser I
  - (10) Aramaean States
  - (11) Peaceful Development
  - (12) Shalmaneser II
  - (13) Tiglath-pileser III
  - (14) Shalmaneser IV and Sargon
  - (15) Pharaoh-necho and Nebuchadnezzar

The name does not occur in the MT nor the Pesh of the OT, but is found in the LXX, in the Pesh of the NT and in the Mish. In the

**1. Name and Its Origin** LXX it represents "Aram" in all its combinations, as Aram-zobah, etc. The name itself first appears in Herodotus vii.63, where he says that "Syrians" and "Assyrians" were the Gr and barbarian designations of the same people. Otherwise he is quite vague in his use of the term. Xenophon is clearer when he (*Anab.* vii.8, 25) distinguishes between Syria and Phoenicia. Syria is undoubtedly an extension of the name "Suri," the ancient Bab designation of a district in North Mesopotamia, but later embracing regions beyond the Euphrates to the N. and W., as far as the Taurus. Under the Seleucidae, Syria was regarded as coextensive with their kingdom, and the name shrank with its dimensions. Strabo, Pliny and Ptolemy give its boundaries as the Taurus Mountains, the Euphrates, the Syro-Arabian desert and the Mediterranean, and the territory within these limits is still politically designated Syria, though popularly Pal is generally named separately.

Homer (*Iliad* ii.785) and Hesiod (*Theog.* 304) call the inhabitants of the district "Arimoi," with which of the cuneiform "Arimu" or "Aramu" for Aramaeans. The earliest Assyrian name was "Martu," which Hommel regards as a contraction of "Amartu," the land of the "Amurru" or Amorites. In Egypt records the country is named "Ruten" or "Luten," and divided into "Lower" and "Upper," the former denoting Pal and the latter Syria proper.

(1) *The maritime plain.*—Syria, within the boundaries given, consists of a series of belts of low and high land running N. and S., parallel to the Mediterranean. The first of these is the maritime plain. It consists of a



broad strip of sand dunes covered by short grass and low bushes, followed by a series of low undulating hills and wide valleys which gradually rise to a height of about 500 ft. This belt begins in North Syria with the narrow Plain of Issus, which extends to a few miles S. of Alexandretta, but farther S. almost disappears, being represented only by the broader valleys and the smaller plains occupied by such towns as Latakia, Tripolis and Beirut. S. of the last named the maritime belt is continuous, being interrupted only where the Ladder of Tyre and Mt. Carmel descend abruptly into the sea. In the Plain of Akka it has a breadth of 8 miles, and from Carmel southward it again broadens out, till beyond Caesarea it has an average of 10 miles. Within the sand dunes the soil is a rich alluvium and readily yields to cultivation. In ancient times it was covered with palm trees, which, being thence introduced into Greece, were from their place of origin named *phoenikes*.

**3. Physical**

(2) *First mountain belt.*—From the maritime plain we rise to the first mountain belt. It begins with the Amanus, a branch of the Taurus in the N. Under that name it ceases with the Orontes valley, but is continued in the *Nuseiriyeh* range (Mt. Cassius, 5,750 ft.), till the Eleutherus valley is reached, and thence rising again in Lebanon (average 5,000 ft.), Jebel Sunnin (8,780 ft.), it continues to the Leontes or *Quasmiyeh*. The range then breaks down into the rounded hills of Upper Galilee (3,500 ft.), extends through the table-land of Western Pal (2,500 ft.), and in the S. of Judaea broadens out into the arid *Badiet et-Tih* or Wilderness of Wandering.

(3) *Second mountain belt.*—Along with this may be considered the parallel mountain range. Beginning in the neighborhood of Riblah, the chain of Anti-Lebanon extends southward to Hermon (9,200 ft.), and thence stretches out into the plateau of the Jaulan and Hauran, where we meet with the truncated cones of extinct volcanoes and great sheets of basaltic lava, esp. in *el-Leja* and *Jebel ed-Druz*. The same table-land continues southward, with deep ravines piercing its sides, over Gilead, Moab and Edom.

(4) *Great central valley.*—Between Lebanon and Anti-Lebanon lies the great valley of Coele-Syria. It is continued northward along the Orontes and thence stretches away eastward to the Euphrates, while southward it merges into the valleys of the Jordan and the Arabah. From the sources of the Orontes and Leontes at Baalbek (4,000 ft.) it falls away gently to the N.; but to the S. the descent is rapid. In *Merj 'Ayun* it has sunk to 1,800 ft., at Lake Huleh it is +7 ft., at the Lake of Tiberias -682 ft., and at the Dead Sea -1,292 ft., and thence it rises again to the Gulf of Akabah. This great valley was caused by a line of fault or fracture of the earth's crust, with parallel and branching faults. In ancient times the whole valley formed an arm of the sea, and till the Glacial period at the end of the Tertiary (Pleistocene) Age, a lake extended along the whole Jordan valley as far as the *Huleh*. We can thus understand that the great plain and adjoining valleys consist mainly of alluvial deposits with terraces of gravel and sand on the inclosing slopes. See **LEBANON; NATURAL FEATURES; PALESTINE; PHOENICIA.**

(5) *The eastern belt.*—To the E. of the Anti-Lebanon belt there is a narrow stretch of cultivated land which in some places attains a breadth of several miles, but this is always determined by the distance to which the eastern streams from Anti-Lebanon flow. Around Damascus the Abana (Barada) and neighboring streams have made the district an earthly paradise, but they soon lose themselves in the salt marshes about 10 miles E. of the city. Elsewhere the fruitful strip gradually falls away into the sands and rocks of the Syrian desert, barren alike of vegetable and animal life.

(6) *Rivers.*—The mountain ranges determine the course of the rivers and their length. The streams flowing westward are naturally short and little more than summer torrents. Those flowing to the desert are of the same character, the only one of importance being the Abana, to which Damascus owes its existence. Only the great central valley permits the formation of larger rivers, and there we find the Orontes and Leontes rising within a few feet of each other beside Baalbek, and draining Coele-Syria to the N. and S., till breaking through the mountains they reach the sea. The Jordan is the only other stream of any size. In ancient, as also in modern times, the direction of these streams determined the direction of the great trade route from Mesopotamia to Egypt through Coele-Syria and across Pal, as also the position of the larger

towns, but, not being themselves navigable, they did not form a means of internal communication.

(7) *Nature of the soil.*—The variation in altitude both above and below the sea-level is naturally conducive to a great variety of climate, while the nature of the disintegrating rocks and the alluvial soil render great productivity possible. Both of the mountain belts in their whole length consist chiefly of cretaceous limestone, mixed with friable limestone with basaltic intrusions and volcanic products. The limestone is highly porous, and during the rainy season absorbs the moisture which forms reservoirs and feeds the numerous springs on both the eastern and western slopes. The rocks too are soft and penetrable and can easily be turned into orchard land, a fact that explains how much that now appears as barren wastes was productive in ancient times as gardens and fruitful fields (Bab Talm, *M<sup>gh</sup>*. 6a).

(8) *Flora.*—The western valleys and the maritime plain have the flora of the Mediterranean, but the eastern slopes and the valleys facing the desert are poorer. On the southern coasts and in the deeper valleys the vegetation is tropical, and there we meet with the date-palm, the sugar-cane and the sycamore. Up to 1,600 ft., the products include the carob and the pine, after which the vine, the fig and the olive are met with amid great plantations of dwarf oak, till after 3,000 ft. is reached, then cypresses and cedars till the height of 6,200 ft., after which only Alpine plants are found. The once renowned "cedars of Lebanon" now exist only in the Kadisha and Baruk valleys. The walnut and mulberry are plentiful everywhere, and wheat, corn, barley, maize and lentils are widely cultivated. Pasture lands are to be found in the valleys and plains, and even during the dry season sheep, goats and cattle can glean sufficient pasturage among the low brushwood.

(9) *Fauna.*—The animal world is almost as varied. The fox, jackal, hyena, bear, wolf and hog are met nearly everywhere, and small tigers are sometimes seen (cf 2 K 14 9). The eagle, vulture, partridge and blue pigeon are plentiful, and gay birds chirp everywhere. The fish in the Jordan and its lakes are peculiar and interesting. There are in all 22 varieties, the largest being a kind of perch, the coracinus, which is known elsewhere also in the Nile (Jos, *Ant*, III, x, 8), and a peculiar old-world variety locally named 'Abu-musht.

(10) *Minerals.*—In both the eastern and the western mountain belts there are abundant supplies of mineral wealth. They consist chiefly of coal, iron, bitumen, asphalt and mineral oil, but they are mostly unworked. In the Jordan valley all the springs below the level of the Mediterranean are brackish, and many of them are also hot and sulphurous, the best known being those at Tiberias.

(11) *Central position.*—The country, being in virtue of its geographical configuration separated into small isolated districts, naturally tended to break up into a series of petty independent states. Still the central position between the Mesopotamian empires on the one hand and Egypt and Arabia on the other made it the highway through which the trade of the ancient world passed, gave it an importance far in excess of its size or productivity, and made it a subject of contention whenever East and West were ruled by different powers.

(1) *Canaanitic Semites.*—When history begins for us in the 3d millennium BC, Syria was already occupied by a Sem population belonging to the Canaanitic wave of immigration, i.e. such as spoke dialects akin to Heb or Phoen. The Semites had been already settled for a considerable time, for a millennium earlier in Egypt we find Sem names for Syrian

#### 4. History

articles of commerce, as well as Semites depicted on the Egypt monuments.

(2) *Sargon of Agade*.—Omitting as doubtful references to earlier relations between Babylonia and Syria, we may consider ourselves on solid ground in accepting the statements of the *Omen Tablets* which tell us that Sargon of Agade (2750 BC) four times visited the land of Martu and made the peoples of one accord. His son Naram-sin, while extending the empire in other directions, maintained his authority here also. Commercial relations were continued, and Babylonia claimed at least a supremacy over Martu, and at times made it effective.

(3) *Babylonian supremacy*.—Hammurabi and also his great-grandson Ammisatana designate themselves in inscriptions as kings of Martu, and it is very likely that other kings maintained the traditional limits of the empire. The long-continued supremacy of Babylon not only made itself felt in imposing place-names, but it made Assyrian the language of diplomacy, even between Syria and Egypt, as we see in the Am Tab.

(4) *Hittite and Aramaean*.—By the middle of the 2d millennium BC we find considerable change in the population. The Mitanni, a Hittite people, the remains of whose language are to be found in the still undeciphered inscriptions at Carchemish, Marash, Aleppo and Hamath, are now masters of North Syria. See HITTITES.

The great discoveries of Dr. H. Winckler at Boghazkeui have furnished a most important contribution to our knowledge. The preliminary account may be found in *OLZ*, December 15, 1906, and the *Mitteilungen der deutschen orient. Gesellschaft*, no. 35, December, 1907.

Elsewhere the Aramaean wave has become the predominant Sem element of population, the Canaanitic now occupying the coast towns (Phoenicians) and the Canaan of the OT.

(5) *Hittites and Egyptians*.—At this time Babylonia was subject to the Kassites, an alien race of kings, and when they fell, about 1100 BC, they gave place to a number of dynasties of short duration. This gave the Egyptians, freed from the Hyksos rule, the opportunity to lay claim to Syria, and accordingly we find the struggle to be between the Hittites and the Egyptians. Thothmes I, about 1600 BC, overran Syria as far as the Euphrates and brought the country into subjection. Thothmes III did the same, and he has left us on the walls of Karnak an account of his campaigns and a list of the towns he conquered.

(6) *Amarna period*.—In the reign of Thothmes IV the Hittites began to leave their mountains more and more and to press forward into Central Syria. The Am Tab show them to be the most serious opponents to the Egypt authority in Syria and Pal during the reign of Amenhotep IV (c 1380 BC), and before Seti I came to the throne the power of the Pharaohs had greatly diminished in Syria. Then the Egypt sphere only reached to Carmel, while a neutral zone extended thence to Kadesh, northward of which all belonged to the Hittites.

(7) *Rameses II*.—Rameses II entered energetically into the war against Hatesar, king of the Hittites, and fought a battle near Kadesh. He claims a great victory, but the only result seems to have been that his authority was further extended into the neutral territory, and the sphere of Egypt influence extended across Syria from the Lycus (Dog River) to the S. of Damascus. The arrangement was confirmed by a treaty in which North Syria was formally recognized as the Hittite sphere of influence, and, on the part of the Assyrians who were soon to become the heirs of the Hittite pretensions, this treaty formed the basis of a claim against Egypt. About the year 1200 BC the

Hittites, weakened by this war, were further encroached upon by the movements of northern races, and the empire broke up into a number of small separate independent states.

(8) *Philistines*.—Among the moving races that helped to weaken and break up the Hittite influence in Syria were the Pulusati (or Purusati), a people whose origin is not yet definitely settled. They entered Syria from the N. and overcame all who met them, after which they encamped within the Egypt sphere of influence. Rameses III marched against them, and he claims a great victory. Later, however, we find them settled in Southeastern Pal under the name of Philis. Their settlement at that time is in harmony with the Am Tab in which we find no trace of them, while in the 11th cent. BC they are there as the inveterate foes of Israel.

(9) *Tiglath-pileser I*.—Assyria was now slowly rising into power, but it had to settle with Babylon before it could do much in the W. Tiglath-pileser I, however, crossed the Euphrates, defeated the Hittite king of Carchemish, advanced to the coast of Arvad, hunted wild bulls in Lebanon and received gifts from the Pharaoh, who thus recognized him as the successor of the Hittites in North Syria.

(10) *Aramaean states*.—When the Hittite empire broke up, the Aramaeans in Central Syria, now liberated, set up a number of separate Aramaean states, which engaged in war with one another, except when they had to combine against a common enemy. Such states were established in Hamath, Hadrach, Zobah and Rehob. The exact position of Hadrach is still unknown, but Hamath was evidently met on its southern border by Rehob and Zobah, the former extending along the *Big'a* to the foot of Hermon, while the latter stretched along the eastern slopes of Anti-Lebanon and included Damascus, till Rezon broke away and there set up an independent kingdom, which soon rose to be the leading state; S.E. of Hermon were the two smaller Aramaean states of Geshur and Maacah.

(11) *Peaceful development*.—For nearly three centuries now, Syria and Pal were, except on rare occasions, left in peace by both Mesopotamia and Egypt. In the 12th cent. BC Babylonia was wasted by the Elamite invasion, and thereafter a prolonged war was carried on between Assyria and Babylonia, and although a lengthened period of peace succeeded, it was wisely used by the peaceful rulers of Assyria for the strengthening of their kingdom internally. In Egypt the successors of Rameses III were engaged against the aggressive Theban hierarchy. During the XX1st Dynasty the throne was usurped by the high priests of Amen, while the XXII<sup>d</sup> were Lybian usurpers, and the three following dynasties Ethiopian conquerors.

(12) *Shalmaneser II*.—In the 9th cent. Assurnazirpal crossed the Euphrates and overran the recently established state of Patin in the Plain of Antioch. He besieged its capital and planted a colony in its territory, but the arrangement was not final, for his successor, Shalmaneser II, had again to invade the territory and break up the kingdom into a number of small principalities. Then in 854 BC he advanced into Central Syria, but was met at Karkar by a strong confederacy consisting of Ben-hadad of Damascus and his Syrian allies including Ahab of Israel. He claims a victory, but made no advance for 5 years. He then made three unsuccessful expeditions against Damascus, but in 842 received tribute from Tyre, Sidon and Jehu of Israel, as recorded and depicted on the Black Obelisk. It was not till the year 797 that Ramman-nirari, after subduing the coast of Phoenicia, was able to reduce Mari'a of Damascus to obedience, at which time also he seems to have

carried his conquests through Eastern Pal as far as Edom. The Assy power now suffered a period of decline, during which risings took place at Hadrach and Damascus, and Jeroboam II of Israel was able (2 K 14 25) to extend his boundaries northward to the old limits.

(13) *Tiglath-pileser III.*—It thus happened that Tiglath-pileser III (745–728) had to reconquer the whole of Syria. He captured Arpad after two years' warfare (742–740). Then he divided the territory of Hamath among his generals. At this juncture Ahaz of Judah implored his aid against Rezin of Damascus and Remaliah of Israel. Ahaz was relieved, but was made subject to Assyria. Damascus fell in 732 BC and a Great Court was held there, which the tributary princes of Syria, including Ahaz (2 K 16 10), attended. The Assy empire now possessed the whole of Syria as far as the River of Egypt. Sibahe, however, encouraged revolt in what had been the Egypt sphere of influence, and insurrections took place in Phoenicia and Samaria.

(14) *Shalmaneser IV and Sargon.*—After some difficulty Shalmaneser IV compelled Tyre and Sidon to submit and to pay tribute. Samaria, too, was besieged, but was not taken till Sargon came to the throne in 722. Hamath and Carchemish again rose, but were finally reduced in 720 and 717 respectively. Again in 711 Sargon overran Pal and broke up a fresh confederacy consisting of Egypt, Moab, Edom, Judah and the Philis. In 705 the Egyptians under Sibahe and their allies the Philis under Hanun of Gaza were defeated at Raphia.

The last three rulers of Assyria were in constant difficulties with Babylonia and a great part of the empire was also overrun by the Scythians (c 626 BC), and so nothing further was done in the W. save the annexation of the mainland possessions of Phoenicia.

(15) *Pharaoh-necho and Nebuchadnezzar.*—In 609 when Assyria was in the death grapple with Babylonia, Pharaoh-necho took advantage of the situation, invaded Syria, and, defeating Josiah en route, marched to Carchemish. In 605, however, he was there completely defeated by Nebuchadnezzar, and the whole of Syria became tributary to Babylonia. The former Syrian states now appear as Bab provinces, and revolts in Judah reduced it also to that position in 586 BC.

Under Pers rule these provinces remained as they were for a time, but ultimately "Ebir nari" or Syria was formed into a satrapy. The Gr conquest with the Ptolemies in Egypt and the Seleucidae in Babylon brought back some of the old rivalry between E. and W., and the same unsettled conditions. On the advent of Rome, Syria was separated from Babylonia and made into a province with Antioch as its capital, and then the Sem civilization which had continued practically untouched till the beginning of the Christian era was brought more and more into contact with the W. With the advent of Islam, Syria fell into Arab hands and Damascus became for a short time (661–750 AD) the capital of the new empire, but the central authority was soon removed to Babylonia. Thenceforward Syria sank to the level of a province of the caliphate, first Abbasside (750–1258), then Fatimite (1258–1517), and finally Ottoman. W. M. CHRISTIE

**SYRIA-MAACHAH**, sir'i-a-mā'a-ka. See MAACHAH; SYRIA.

**SYRIAC**, sir'i-ak: In Dnl 2 4, for AV "Syriack" RV has "Syrian," and in m "Or, 'in Aramaic.'" See ARAMAIC LANGUAGE; LANGUAGES OF THE OT.

## SYRIAC VERSIONS:

1. Analogy of Latin Vulgate
2. The Designation "Peshito" ("Peshitta")
3. Syriac OT
4. Syriac NT
5. Old Syriac Texts
  - (1) Curetonian
  - (2) Tatian's *Diatessaron*
  - (3) Sinaitic Syriac
  - (4) Relation to Peshito
6. Probable Origin of Peshito
7. History of Peshito
8. Other Translations
  - (1) The Philoxenian
  - (2) The Harclean
  - (3) The Jerusalem Syriac

## LITERATURE

As in the account of the Lat VSS it was convenient to start from Jerome's Vulg, so the Syr VSS may be usefully approached from the Pesh, which is the Syr Vulg.

Not that we have any such full and clear knowledge of the circumstances under which the Pesh was produced and came into circulation. Whereas the authorship of the Lat Vulg has never been in dispute, almost every assertion regarding the authorship of the Pesh, and the time and place of its origin, is subject to question. The chief ground of analogy

between the Vulg and the Pesh is that both came into existence as the result of a revision. This, indeed, has been strenuously denied, but since Dr. Hort in his *Intro* to Westcott and Hort's *NT in the Original Gr*, following Griesbach and Hug at the beginning of the last century, maintained this view, it has gained many adherents. So far as the Gospels and other NT books are concerned, there is evidence in favor of this view which has been added to by recent discoveries; and fresh investigation in the field of Syr scholarship has raised it to a high degree of probability. The very designation, "Peshito," has given rise to dispute. It has been applied to the Syr as the version *in common use*, and regarded as equivalent to the Gr κοινή (*koine*) and the Lat *Vulg.*

The word itself is a fem. form (*peshitā*), meaning "simple," "easy to be understood." It seems to have been used to distinguish the

version from others which are en-Designation cumbered with marks and signs in "Peshito" the nature of an *apparatus criticus*.

However this may be, the term as a designation of the version has not been found in any Syr author earlier than the 9th or 10th cent.

As regards the OT, the antiquity of the Version is admitted on all hands. The tradition, however, that part of it was tr<sup>d</sup> from Heb into Syr for the benefit of Hiram in the days of Solomon is a myth. That a tr was made by a priest named Assa, or Ezra, whom the king of Assyria sent to Samaria, to instruct the Assy colonists mentioned in 2 K 17, is equally legendary. That the tr of the OT and NT was made in connection with the visit of Thaddaeus to Abgar at Edessa belongs also to unreliable tradition. St. Mark has even been credited in ancient Syr tradition with translating his own Gospel (written in Lat, according to this account) and the other books of the NT into Syr.

But what Theodore of Mopsuestia says of the OT is true of both: "These Scriptures were tr<sup>d</sup> into the tongue of the Syrians by someone

indeed at some time, but who on earth this was has not been made known

down to our day" (Nestle in *HDB*, IV, 645b).

Professor Burkitt has made it probable that the tr of the OT was the work of Jews, of whom there was a colony in Edessa about the commencement of the Christian era (*Early Eastern Christianity*, 71 ff). The older view was that the translators were Christians, and that the work was done late in the 1st cent. or early in the 2d. The OT known to the early Syrian church was substantially that of the Palestinian Jews. It contained the same number of books but it arranged them in a different order. First there was the Pent, then Job, Josh, Jgs, 1 and 2 S, 1 and 2 K, 1 and 2 Ch, Pss, Prov, Eccl, Ruth, Cant, Est, Ezr, Neh, Isa followed by the Twelve Minor Prophets, Jer and Lam, Ezk, and lastly Dnl. Most of the apocryphal books of the OT are found

in the Syr, and the Book of Sir is held to have been tr<sup>d</sup> from the Heb and not from the LXX.

Of the NT, attempts at translation must have been made very early, and among the ancient VSS of NT Scripture the Syr in all likelihood is the earliest. It was at Antioch, the capital of Syria, that the disciples of Christ were first called Christians, and it seemed natural that the first tr of the Christian Scriptures should have been made there. The tendency of recent research, however, goes to show that Edessa, the literary capital, was more likely the place.

If we could accept the somewhat obscure statement of Eusebius (*HE*, IV, xxii) that Hegesippus "made some quotations from the Gospel according to the Hebrews and from the Syr Gospel," we should have a reference to a Syr NT as early as 160-80 AD, the time of that Heb Christian writer. One thing is certain, that the earliest NT of the Syr church lacked not only the *Antilegomena*—2 Pet, 2 and 3 Jn, Jude, and Rev—but the whole of the Catholic Epp. and the Apocalypse. These were at a later date tr<sup>d</sup> and received into the Syr Canon of the NT, but the quotations of the early Syrian Fathers take no notice of these NT books.

From the 5th cent., however, the Pesh containing both OT and NT has been used in its present form only as the national version of the Syr Scriptures. The tr of the NT is careful, faithful and literal, and the simplicity, directness and transparency of the style are admired by all Syr scholars and have earned for it the title of "Queen of the VSS."

It is in the Gospels, however, that the analogy between the Lat Vulg and the Syr Vulg can be established by evidence. If the Pesh is the result of a revision as the Vulg was, then we may expect to find Old Syr texts answering to the Old Lat. Such texts have actually been found.

Three such texts have been recovered, all showing divergences from the Pesh, and believed by competent scholars to be anterior to it. These are, to take them in the order of their recovery in modern times, (1) the Curetonian Syr, (2) the Syr of Tatian's *Diatessaron*, and (3) the Sinaitic Syr. They are known respectively as  $\mathfrak{S}^c$ ,  $\mathfrak{S}^t$ ,  $\mathfrak{S}^s$ , the Pesh being  $\mathfrak{S}^p$ .

(1) *Curetonian Syriac*.—The Curetonian consists of fragments of the Gospels brought in 1842 from the Nitrian Desert in Egypt, and now in the British Museum. The fragments were examined by Canon Cureton of Westminster and edited by him in 1858. The MS from which the fragments have come appears to belong to the 5th cent., but scholars believe the text itself to be as old as the 2d cent. In this recension the Gospel according to St. Matthew has the title *Evangelion da-Mepharreshê*, which will be explained in the next section.

(2) *Tatian's "Diatessaron."*—The *Diatessaron* of Tatian is the work which Eusebius ascribes to that heretic, calling it that "combination and collection of the Gospels, I know not how, to which he gave the title *Diatessaron*." It is the earliest harmony of the Four Gospels known to us. Its existence is amply attested in the church of Syria, but it had disappeared for centuries, and not a single copy of the Syr work survives.

A commentary upon it by Ephraem the Syrian, surviving in an Armenian tr, was issued by the Mechitarist Fathers at Venice in 1836, and afterward tr<sup>d</sup> into Lat. Since 1876 an Arab. tr of the *Diatessaron* itself has been discovered; and it has been ascertained that the Cod. Fuldensis of the Vulg represents the order and contents of the *Diatessaron*. A tr from the Arab. can now be read in Eng. in Dr.

J. Hamlyn Hill's *The Earliest Life of Christ Ever Compiled from the Four Gospels*.

Although no copy of the *Diatessaron* has survived, the general features of Tatian's Syr work can be gathered from these materials. It is still a matter of dispute whether Tatian composed his Harmony out of a Syr version already made, or composed it first in Gr and then tr<sup>d</sup> it into Syr. But the existence and widespread use of a Harmony, combining in one all four Gospels, from such an early period (172 AD), enables us to understand the title *Evangelion da-Mepharreshê*. It means "the Gospel of the Separated," and points to the existence of single Gospels, Mt, Mk, Lk, Jn, in a Syr tr, in contradistinction to Tatian's Harmony. Theodoret, bishop of Cyrhus in the 5th cent., tells how he found more than 200 copies of the *Diatessaron* held in honor in his diocese and how he collected them, and put them out of the way, associated as they were with the name of a heretic, and substituted for them the Gospels of the four evangelists in their separate forms.

(3) *The Sinaitic Syriac*.—In 1892 the discovery of the 3d text, known, from the place where it was found, as the Sin Syr, comprising the four Gospels nearly entire, heightened the interest in the subject and increased the available material. It is a palimpsest, and was found in the monastery of St. Catherine on Mt. Sinai by Mrs. Agnes S. Lewis and her sister Mrs. Margaret D. Gibson. The text has been carefully examined and many scholars regard it as representing the earliest tr into Syr, and reaching back into the 2d cent. Like the Curetonian, it is an example of the *Evangelion da-Mepharreshê* as distinguished from the Harmony of Tatian.

(4) *Relation to Peshito*.—The discovery of these texts has raised many questions which it may require further discovery and further investigation to answer satisfactorily. It is natural to ask what is the relation of these three texts to the Pesh. There are still scholars, foremost of whom is G. H. Gwilliam, the learned editor of the Oxford *Peshito* (*Tetraevangelium sanctum*, Clarendon Press, 1901), who maintain the priority of the Pesh and insist upon its claim to be the earliest monument of Syrian Christianity. But the progress of investigation into Syr Christian lit. points, distinctly the other way. From an exhaustive study of the quotations in the earliest Syr Fathers, and, in particular, of the works of Ephraem Syrus, Professor Burkitt concludes that the Pesh did not exist in the 4th cent. He finds that Ephraem used the *Diatessaron* in the main as the source of his quotation, although "his voluminous writings contain some clear indications that he was aware of the existence of the separate Gospels, and he seems occasionally to have quoted from them" (*Evangelion da-Mepharreshê*, 186). Such quotations as are found in other extant remains of Syr lit. before the 5th cent. bear a greater resemblance to the readings of the Curetonian and the Sinaitic than to the readings of the Pesh. Internal and external evidence alike point to the later and revised character of the Pesh.

How and where and by whom was the revision carried out? Dr. Hort, as we have seen, believed that the "revised" character of the

6. Probable Syr Vulg was a matter of certainty, Origin of and Dr. Westcott and he connected the Peshito authoritative revision which resulted in the Pesh with their own theory, now widely adopted by textual critics, of a revision of the Gr text made at Antioch in the latter part of the 3d cent., or early in the 4th. The recent investigations of Professor Burkitt and other scholars have made it probable that the Pesh was the work of Rabbûla, bishop of Edessa, at the beginning of

the 5th cent. Of this revision, as of the revision which plays such an important part in the textual theory of Westcott and Hort, direct evidence is very scanty, in the former case altogether wanting. Dr. Burkiitt, however, is able to quote words of Rabbūla's biographer to the effect that "by the wisdom of God that was in him he tr<sup>d</sup> the NT from Gr into Syr because of its variations, exactly as it was." This may well be an account of the first publication of the Syr Vulg, the Old Syr texts then available having been brought by this revision into greater conformity with the Gr text current at Antioch in the beginning of the 5th cent. And Rabbūla was not content with the publication of his revision; he gave orders to the priests and the deacons to see that "in all the churches a copy of the *Evangelion da-Mepharreshē* shall be kept and read" (ib 161 ff, 177 f). It is very remarkable that before the time of Rabbūla, who ruled over the Syr-speaking churches from 411 to 435, there is no trace of the Pesh, and that after his time there is scarcely a vestige of any other text. He very likely acted in the manner of Theodoret somewhat later, pushing the newly made revision, which we have reason to suppose the Pesh to have been, into prominence, and making short work of other texts, of which only the Curetonian and the Sinaitic are known to have survived to modern times.

The Pesh had from the 5th cent. onward a wide circulation in the East, and was accepted and honored by all the numerous sects of the 7. **History** greatly divided Syr Christianity. It of Peshito had a great missionary influence, and the Armenian and Georgian VSS, as well as the Arab. and the Pers, owe not a little to the Syr. The famous Nestorian tablet of Sing-an-fu witnesses to the presence of the Syr Scriptures in the heart of China in the 7th cent. It was first brought to the West by Moses of Mindin, a noted Syrian ecclesiastic, who sought a patron for the work of printing it in vain in Rome and Venice, but found one in the Imperial Chancellor at Vienna in 1555—Albert Widmanstadt. He undertook the printing of the NT, and the emperor bore the cost of the special types which had to be cast for its issue in Syr. Immanuel Tremellius, the converted Jew whose scholarship was so valuable to the Eng. reformers and divines, made use of it, and in 1569 issued a Syr NT in Heb letters. In 1645 the *editio princeps* of the OT was prepared by Gabriel Sionita for the Paris Polyglot, and in 1657 the whole Pesh found a place in Walton's London Polyglot. For long the best edition of the Pesh was that of John Leusden and Karl Schaaf, and it is still quoted under the symbol Syr<sup>Schaaf</sup>, or Syr<sup>Sch</sup>. The critical ed of the Gospels recently issued by Mr. G. H. Gwilliam at the Clarendon Press is based upon some 50 MSS. Considering the revival of Syr scholarship, and the large company of workers engaged in this field, we may expect further contributions of a similar character to a new and complete critical edition of the Pesh.

(1) *The Philoxenian*.—Besides the Pesh there are other tr<sup>s</sup> which may briefly be mentioned. One of these is the Philoxenian, made by Philoxenus, bishop of Mabug (485–519) on Translations the Euphrates, from the Gr, with the help of his Chorepiscopus Polycarp. The Pss and portions of Isa are also found in this version; and it is interesting as having contained the *Antilegomena*—2 Pet, 2 and 3 Jn, and Jude.

(2) *The Harelean*.—Another is the Harelean, which is a revision of the Philoxenian, undertaken by Thomas of Harkel in Mesopotamia, and carried out by him at Alexandria about 616, with the help of Gr MSS exhibiting western readings. The OT was undertaken at the same time by Paul of Tella.

The NT contains the whole of the books, except Rev. It is very literal in its renderings, and is supplied with an elaborate system of asterisks and daggers to indicate the variants found in the MSS.

(3) *The Jerusalem Syriac*.—Mention may also be made of a Syr version of the NT known as the Jerusalem or Palestinian Syr, believed to be independent, and not derived genealogically from those already mentioned. It exists in a Lectionary of the Gospels in the Vatican, but two fresh MSS of the Lectionary have been found on Mt. Sinai by Dr. Rendel Harris and Mrs. Lewis, with fragments of Acts and the Pauline Epp. The dialect employed deviates considerably from the ordinary Syr, and the Gr text underlying it has many peculiarities. It alone of Syr MSS has the *pericope adulterae*. In Mt 27 17 the robber is called Jesus Barabbas. Gregory describes 10 MSS (*Textkritik*, 523 f).

LITERATURE.—Nestle, *Syrische Uebersetzungen*, PRE<sup>3</sup>, *Syriac VSS*, HDB, and *Intro to the Textual Criticism of the Gr NT*, 95–106; G. H. Gwilliam, *Studia Biblica*, II, 1890, III, 1891, V, 1903, and *Tetraevangelium sanctum Syriacum*; Scrivener, *Intro*, 6–40; Burkiitt, "Early Eastern Christianity," *Texts and Studies*, VII, 2 1–91, *Evangelion da-Mepharreshē*, I, II, and "Syr VSS," *EB*; Gregory, *Textkritik*, 479–528.

T. NICOL

**SYRIAN**, sir'i-an (AV SYRIACK), LANGUAGE. See SYRIAC.

**SYRIANS**, sir'i-anz (ܣܘܪܝܝܐ, 'ārām; Σύροι, Sūroi; Assyr Aramu, Arumu, Arimu):

1. Division of Aram
2. A Semitic Race
3. Syria and Israel
4. Under Nabathaeans and Palmyrenes
5. A Mixed Race, Semitic Type
6. Religion

The terms "Syria" and "Syrians" are used in two senses in the Bible. In the OT they are uniformly "Aram," "Aramaean," while in the NT they are used in a wider and more indefinite sense (Mt 4 24; Acts 15 23; 18 18; Gal 1 21), and include all the dwellers of the land whether Aramaeans or not.

Aram was divided into several districts, comprising, in general, the region to the E. of the Jordan, but extending in the N. over 1. **Division** most of Northern Syria, or from the of Aram Orontes eastward, and Northern Mesopotamia. This latter division was called Aram-naharaim—Aram of the two rivers, i.e. Tigris and Euphrates—and is the Nahrina of the Eyp inscriptions. It is also called Paddan-aram in the OT (Gen 25 20) or field of Aram (Hos 12 12). The most important of the divisions of Aram in OT times was Aram-dammeseq, the Syria of Damascus, which sometimes dominated all of the other divisions lying to the S., such as Rehob, Tob, Zobah, and Maacah (2 S 10 8). Geshur was in this region and should be reckoned as an Aramaean district (2 S 15 8).

The Aramaeans were of Sem stock and closely akin to the Hebrews. Aram is called a son of Shem (Gen 10 22), which means a 2. **A Sem-** descendant, for we find him after- itic Race ward called a grandson of Nahor, the brother of Abraham (Gen 22 21).

The Israelites were taught to say "A Syrian [Aramaean] ready to perish was my father" (Dt 26 5), and the kinship of the Hebrews and Aramaeans was further cemented by the marriage of Isaac with Rebekah, the sister of Laban the Syrian, and of Jacob with his daughters (Gen 24, 29). The period when the Aramaeans first appeared in Syria is uncertain, but was probably later than 2000 BC. When Abraham came from Haran, Damascus was already occupied (Gen 15 2), and this may have been the oldest settlement of the Aramaeans in

Syria proper, although it is not mentioned on the monuments until long after, in the time of Thothmes III of Egypt, about 1479 BC. The Syrians were generally hostile to the Hebrews and had wars with them from the time of David onward. David subdued them, although they were aided by the tribes from beyond the Euphrates (2 S 10), but after the division of the kingdom they often proved too strong for the northern Israelites.

In the days of Omri the Syrians of Damascus brought them into subjection, but Ahab recovered

all the lost territory and Damascus seems to have been subordinate for a time (1 K 20 34). The king of Damascus afterward regained the supremacy, as appears from the Assy records, for in the war of Shalmaneser II with the peoples of Syria we find them led by Ben-hadad of Damascus and, among his subject allies, Ahab, who furnished 2,000 chariots and 10,000 men. Ben-hadad succeeded in uniting most of the petty kingdoms of Syria together in opposition to Assyria, but could not hold them, and they fell, one after another, as well as Damascus itself, into the hands of the great world-power. Jeroboam II recovered the districts that had been taken from Israel by the Syrians (2 K 14 25), but this was only a temporary success, for Rezin extended his authority over all the East-Jordanic region as far as Elath on the Red Sea (2 K 16 6), and he and Pekah joined in an attack upon Judah, but failed on account of the Assy advance (2 K 16 5-9). Damascus fell into the hands of Tiglath-pileser in 732 BC, and the power of the Syrians was completely broken.

The Aramaic peoples became prominent again under the Nabathaeans and Palmyrenes, both of

whom were of this stock, as their language is clearly Aramaic. The Nabathaeans former established a kingdom extending from the Euphrates to the Red Sea, their capital being Petra, and

Palmyrenes Damascus was under their control in the reign of their king Aretas (el-Harith) (2 Cor 11 32). This kingdom was absorbed by Rome in the reign of Trajan. The Palmyrenes did not come into prominence until the 3d cent. AD, but became, for a short time, the leading power in Western Asia. In the weakness of Rome, under Gallienus, Odenathus and his still more distinguished wife, Zenobia, dominated all Syria, and the latter dared to dispute with Aurelian the empire of the East. With her fall in 272 AD the power of the Aramaeans was extinguished and never revived.

The Syrians in the broader sense have always been a mixed people, though of a prevailing Sem type.

The earliest layer of Sem population was the Amorite which was found in Syria when the first Bab empire extended its authority over the land. Later appear the Canaanites, Phoenicians, Jebusites, Hivites and other tribes,

all of which are classed together as descendants of Canaan in Gen 10, but their Sem character in historic times is undoubted. The Hyksos who were driven from Egypt to Pal and Syria were of the same race, as would appear from the Eyp records. The Aramaeans formed the next wave of Sem stock, but there were others, like the Hittites, who were not Sem, and the Philis, whose race affinity is doubtful. The Egyptians occupied the country for a

long period, but did not contribute much to the population. Some of the tribes brought in by the Assyrians may have been non-Sem, but most of them were evidently of cognate race (2 K 17 24), and the racial characteristics of the Syrians were not changed. When Alexander and his successors brought in the Gr and Macedonian elements there was a decided change in the city population, but little in the country districts, and although the Greeks had a powerful influence upon the civilization of the country the Sem type overcame the admixture of Gr blood and prevailed in the country as a whole. The Romans ruled the country for centuries and established a number of military colonies, but they did not affect the population even as much as the Greeks. When, in the 7th cent. AD, the Mohammedan conquest swept over Syria, it brought in another great wave of pure Sem stock with the numerous Arab settlers, who tended to obliterate any non-Sem elements that might have existed. The effects of the influx of Europeans in the time of the Crusades were not sufficient to produce any marked change, and the same may be said of all later invasions of Turks and Kurds.

The Syrians, while thus a mixed people to a large extent, have maintained the Sem type, but they have never, in all their history, been able to unite politically, and have always been divided, when independent. They have been, during the greater part of their history, under foreign domination, as they still are, under Turkish rule.

The religion of the Syrians in ancient times was undoubtedly similar to that of the Babylonians, as is shown by the names of their gods.

6. Religion The Aramaeans worshipped Hadad and Rimmon (2 K 5 18), sometimes joined as Hadadrimmon (Zec 12 11). Baal, or Bel, Ash-toreth, or Ishtar, were almost universally worshipped, and Nebu, Agli-bol, Melakh-bol, Ati and other deities are found in the Palmyrene inscriptions, showing the Bab influence in their cult. This was to be expected from the known prevalence of Bab culture throughout Western Asia for centuries.

H. PORTER

**SYROPHOENICIAN**, sī'ro-fē-nish'an, sir'ō-(Συροφονίκισσα, *Syrophoinissa*, Συροφονίκισσα; *Syro-phoinikissa*; WH has variant *Súra Phoinikissa*; AV *Syrophenician*): The woman from the borders of Tyre and Sidon whose daughter Jesus healed is described as "a Greek, a Syrophenician by race" (Mk 7 26), and again as "a Canaanitish woman" (Mt 15 22). This seems to mean that she was of Can. descent, a native of the Phoen seaboard, Gr in religion, and probably also in speech. The names Syria and Phoenicia are both applied to the same region in Acts 21 2,3. Syrophenician may therefore denote simply an inhabitant of these parts. According to Strabo (xvii.3), this district was called Syrophenicia to distinguish it from the North African Lybophoenicia. W. EWING

**SYRTIS**, sir'tis (σύρτις, *sýrtis*): RV form for "quicksands" in Acts 27 17. These sandbanks, off the northern coast of Africa, have from early times been regarded as a source of danger to mariners. Virgil refers to them (*Aen.* iv.40f). In Paul's voyage, the ship, driven by a tempestuous wind, *Euraquilo*, was in peril of being cast upon them.

**SYZYGUS**, siz'i-gus. See **SYNZYGUS**.

like a "tent," and the difficulty at once presents itself of how, in such a structure, "sagging" of the roof was to be prevented. Mr. J. Fergusson, in his art. "Temple" in Smith's *DB*, accordingly, advanced the other conception that the structure was essentially that of a tent, with ridge-pole, sloping roof, and other appurtenances of such an erection. He plausibly, though not with entire success, sought to show how this construction answered accurately to the measurements and other requirements of the text (e.g. the mention of "pins of the tabernacle," Ex 35 18). With slight modification this view here commends itself as having most in its favor.

To avoid the difficulty of the ordinary view, that the coverings, hanging down *outside* the framework, are unseen from within, except on the roof, it has sometimes been argued that the tapestry covering hung down, not outside, but *inside* the tabernacle (Keil, Bähr, etc.). It is generally felt that this arrangement is inadmissible. A newer and more ingenious theory is that propounded by A. R. S. Kennedy in his art. "Tabernacle" in *HDB*. It is that the "boards" constituting the framework of the tabernacle were, not solid planks, but really open "frames," through which the finely wrought covering could be seen from within. There is much that is fascinating in this theory, if the initial assumption of the flat roof is granted, but it cannot be regarded as being yet satisfactorily made out. Professor Kennedy argues from the excessive weight of the solid "boards." It might be replied: In a purely "ideal" structure such as he supposes this to be, what does the weight matter? The "boards," however, need not have been so thick or heavy as he represents.

In the minuter details of construction yet greater diversity of opinion obtains, and imagination is often allowed a freedom of exercise incompatible with the sober descriptions of the text.

The attempt at reconstruction of the tabernacle begins naturally with the "court" (*hāqēr*)

or outer inclosure in which the taber-

**1. Inclosure** nacle stood (see COURT OF SANCTUARY). The description is given in Ex 27 9-18; 38 9-20. The court

is to be conceived of as an inclosed space of 100 cubits (150 ft.) in length, and 50 cubits (75 ft.) in breadth, its sides formed (with special arrangement for the entrance) by "hangings" or curtains (*ḥāḏā'im*) of "fine twined linen," 5 cubits (7½ ft.) in height, supported by pillars of brass (bronze) 5 cubits apart, to which the hangings were attached by "hooks" and "fillets" of silver. It thus consisted of two squares of 50 cubits each, in the anterior of which (the easterly) stood the "altar of burnt-offering" (see ALTAR), and the "laver" (see LAVER), and in the posterior (the westerly) the tabernacle itself. From Ex 30 17-21 we learn that the laver—a large (bronze) vessel for the ablutions of the priests—stood between the altar and the tabernacle (ver 18). The pillars were 60 in number, 20 being reckoned to the longer sides (N. and S.), and 10 each to the shorter (E. and W.). The pillars were set in "sockets" or bases (*'ēden*) of brass (bronze), and had "capitals" (AV and ERV "chapters") overlaid with silver (38 17). The "fillets" are here, as usually, regarded as silver rods connecting the pillars; some, however, as Ewald, Dillmann, Kennedy, take the "fillet" to be an ornamental band round the base of the capital. On the eastern side was the "gate" or entrance. This was formed by a "screen" (*māṣākḥ*) 20 cubits (30 ft.) in breadth, likewise of fine twined linen, but distinguished from the other (white) hangings by being embroidered in "blue, and purple, and scarlet" (see EAST GATE). The hangings on either side of the "gate" were 15 cubits in breadth. The 10

pillars of the east side are distributed—4 to the entrance screen, 3 on either side to the hangings. The enumeration creates some difficulty till it is remembered that in the reckoning round the court no pillar is counted twice, and that the corner pillars and those on either side of the entrance

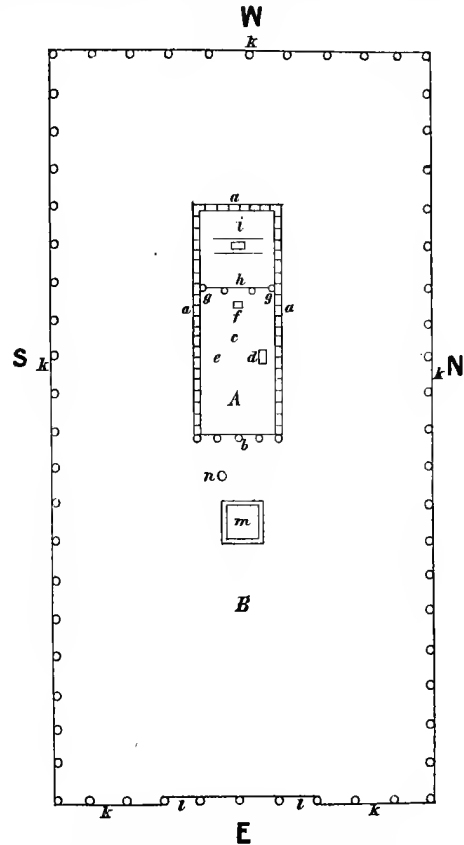

Ground Plan, according to Keil.

- A. The Dwelling-Place**  
*a*, the framework; *b*, the pillars of the entrance; *c*, the holy place; *d*, the table of shewbread; *e*, the candlestick; *f*, the altar of incense; *g*, the veil and pillars; *h*, the Holy of Holies; *i*, the ark and mercy-seat.
- B. The Court**  
*k*, the pillars of the court; *l*, the entrance curtain and pillars; *m*, the altar of burnt offering; *n*, the laver.

had each to do a double duty. The reckoning is really by the 5-cubit spaces between the pillars. Mention is made (27 19; 38 20) of the "pins" of the court, as well as of the tabernacle, by means of which, in the former case, the pillars were held in place. These also were of brass (bronze).

In the inner of the two squares of the court was reared the tabernacle—a rectangular oblong structure, 30 cubits (45 ft.) long and 10 cubits (15 ft.) broad, divided into two parts, a holy and a most holy (26 33). Attention has to be given here (1) to the coverings of the tabernacle, (2) to its framework and divisions, and (3) to its furniture.

(1) *Coverings of the tabernacle* (Ex 26 1-14; 36 8-19).—The wooden framework of the tabernacle to be afterward described had 3 coverings—one, the immediate covering of the tabernacle or "dwelling," called by the same name, *mishkān* (26 1.6); a second, the "tent" covering of goats' hair; and a third, a protective covering of rams' and seal- (or porpoise-) skins, cast over the whole.

(a) The covering of the tabernacle proper (26 1-6) consisted of 10 curtains (*yər'i'ōth*, lit. "breadth") of fine twined linen, beautifully woven with blue, and purple, and scarlet, and with figures of cherubim. The 10 curtains, each 28 cubits long and 4 cubits broad, were joined together in sets of 5 to form 2 large curtains, which again were fastened by 50 loops and clasps (AV "taches") of gold, so as to make a single great curtain 40 cubits (60 ft.) long, and 28 cubits (42 ft.) broad. (b) The "tent" covering (vs 7-13) was formed by 11 curtains of goats' hair, the length in this case being 30 cubits, and the breadth 4 cubits. These were joined in sets of 5 and 6 curtains, and as before the two divisions were coupled by 50 loops and clasps (this time of bronze), into one great curtain of 44 cubits (66 ft.) in length and 30 cubits (45 ft.) in breadth—an excess of 4 cubits in length and 2 in breadth over the fine tabernacle curtain. (c) Finally, for purposes of protection, coverings were ordered to be made (ver 14) for the "tent" of rams' skins dyed red, and of seal- or porpoise-skins (EV "badgers' skins"). The arrangement of the coverings is considered below.

(2) *The framework of the tabernacle* (Ex 26 15-37; 36 20-38) was, as ordinarily understood, composed of upright "boards" of acacia wood, forming 3 sides of the oblong structure, the front being closed by an embroidered "screen," depending from 5 pillars (26 36,37; see below). These boards, 48 in number (20 each for the north and south sides, and 8 for the west side), were 10 cubits (15 ft.) in height, and 1½ cubits (2 ft. 3 in.) in breadth (the thickness is not given), and were overlaid with gold. They were set by means of "tenons" (lit. "hands"), or projections at the foot, 2 for each board, in 96 silver "sockets," or bases ("a talent for a socket," 38 27). In the boards were "rings" of gold, through which were passed 3 horizontal "bars," to hold the parts together—the middle bar, apparently, on the long sides, extending from end to end (26 28), the upper and lower bars being divided in the center (5 bars in all on each side). The bars, like the boards, were overlaid with gold. Some obscurity rests on the arrangement at the back: 6 of the boards were of the usual breadth (= 9 cubits), but the 2 corner boards appear to have made up only a cubit between them (vs 22-24). Notice has already been taken of the theory (Kennedy, art. "Tabernacle," *HDB*) that the so-called "boards" were not really such, but were open "frames," the 2 uprights of which, joined by cross-pieces, are the "tenons" of the text. It seems unlikely, if this was meant, that it should not be more distinctly explained. The inclosure thus constructed was next divided into 2 apartments, separated by a "veil," which hung from 4 pillars overlaid with gold and resting in silver sockets. Like the tabernacle-covering, the veil was beautifully woven with blue, purple, and scarlet, and with figures of cherubim (vs 31,32; see VEIL). The outer of these chambers, or "holy place," was, as usually computed, 20 cubits long by 10 broad; the inner, or "most holy place," was 10 cubits square. The "door of the tent" (ver 36) was formed, as already stated, by a "screen," embroidered with the above colors, and depending from 5 pillars in bronze sockets. Here also the hooks were of gold, and the pillars and their capitals overlaid with gold (36 38).

Preference has already been expressed for Mr. Fergusson's idea that the tabernacle was not flat-roofed, the curtains being cast over it like drapery, but was tent-like in shape, with ridge-pole, and a sloping roof, raising the total height to 15 cubits. Passing over the ridge pole, and descending at an angle, 14 cubits on either side, the inner curtain would extend 5 cubits beyond the walls of the tabernacle, making an awning of that

width N. and S., while the goats'-hair covering above it, 2 cubits wider, would hang below it a cubit on either side. The whole would be held in position by ropes secured by bronze tent-pins to the ground (27 19; 38 31). The scheme has obvious advantages in that it preserves the idea of a "tent," conforms to the principal measurements, removes the difficulty of "sagging" on the (flat) roof, and permits of the golden boards, bars and rings, on

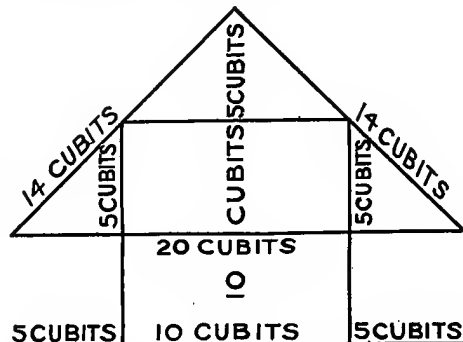

Construction of Tabernacle, according to Fergusson.

the outside, and of the finely wrought tapestry, on the inside, being seen (Professor Kennedy provides for the latter by his "frames," through which the curtain would be visible). On the other hand, it is not to be concealed that the construction proposed presents several serious difficulties. The silence of the text about a ridge-pole, supporting pillars, and other requisites of Mr. Fergusson's scheme (his suggestion that "the middle bar" of 26 28 may be the ridge-pole is quite untenable), may be got over by assuming that these parts are taken for granted as understood in tent-construction. But this does not apply to other adjustments, esp. those connected with the back and front of the tabernacle. It was seen above that the inner covering was 40 cubits in length, while the tabernacle-structure was 30 cubits. How is this excess of 10 cubits in the tapestry-covering dealt with? Mr. Fergusson, dividing equally, supposes a porch of 5 cubits at the front, and a space of 5 cubits also behind, with hypothetical pillars. The text, however, is explicit that the veil dividing the holy from the most holy place was hung "under the clasps" (26 33), i.e. on this hypothesis, midway in the structure, or 15 cubits from either end. Either, then, (1) the idea must be abandoned that the holy place was twice the length of the Holy of Holies (20x10; it is to be observed that the text does not state the proportions, which are inferred from those of Solomon's Temple), or (2) Mr. Fergusson's arrangement must be given up, and the division of the curtain be moved back 5 cubits, depriving him of his curtain for the porch, and leaving 10 cubits to be disposed of in the rear. Another difficulty is connected with the porch itself. No clear indication of such a porch is given in the text, while the 5 pillars "for the screen" (ver 37) are most naturally taken to be, like the latter, at the immediate entrance of the tabernacle. Mr. Fergusson, on the other hand, finds it necessary to separate 2 pillars and screen, and to place the pillars 5 cubits farther in front. He is right, however, in saying that the 5th pillar naturally suggests a ridge-pole; in his favor also is the fact that the extra breadth of the overlying tent-covering was to hang down, 2 cubits at the front, and 2 cubits at the back of the tabernacle (26 9,12). It is possible that there was a special disposition of the inner curtain—that belonging peculiarly to the "dwelling"—according to which its "clasps" lay above the "veil" of the Holy of Holies (20 cubits from the entrance), and its hinder folds closed the aperture at the rear which otherwise would have admitted light into the secrecy of the shrine. But constructions of this kind must ever remain more or less conjectural.

The measurements in the above reckoning are internal. Dr. Kennedy disputes this, but the analogy of the temple is against his view.

(3) *The furniture of the sanctuary* is described in Ex 25 10-40 (ark, table of shewbread, candlestick); 30 1-10 (altar of incense); cf ch 37 for making. In the innermost shrine, the Holy of Holies, the sole object was the ark of the covenant, overlaid within and without with pure gold, with its molding and rings of gold, its staves overlaid with gold passed through the rings, and its lid or covering of solid gold—the propitiatory or mercy-seat—at either end of which, of one piece with it (25 19; 37 8), stood cherubim, with wings out-





TABERNAACLE (SCHICK'S MODEL)



stretched over the mercy-seat and with faces turned toward it (for details see **ARK OF COVENANT**; **MERCY-SEAT**; **CHERUBIM**). This was the meeting-place of Jeh and His people through Moses (25 22). The ark contained only the two tables of stone, hence its name, "the ark of the testimony" (25 16,22). It is not always realized how small an object the ark was—only 2½ cubits (3 ft. 9 in.) long, 1½ cubits (2 ft. 3 in.) broad, and the same (1½ cubits) high.

The furniture of the outer chamber of the tabernacle consisted of (a) the table of shewbread; (b) the golden candlestick; (c) the altar of incense, or golden altar. These were placed, the table of shewbread on the north side (40 22), the candlestick on the south side (40 24), and the altar of incense in front of the veil, in the holy place.

(a) The table of shewbread was a small table of acacia wood, overlaid with gold, with a golden rim round the top, gold rings at the corners of its 4 feet, staves for the rings, and a "border" (at middle?) joining the legs, holding them together. Its dimensions were 2 cubits (3 ft.) long, 1 cubit (18 in.) broad, and 1½ cubits (2 ft. 3 in.) high. On it were placed 12 cakes, renewed each week, in 2 piles (cf Lev 24 5-9), together with dishes (for the bread), spoons (incense cups), flagons and bowls (for drink offerings), all of pure gold (see **SHEWBREAD**, **TABLE OF**).

(b) The candlestick or lampstand was the article on which most adornment was lavished. It was of pure gold, and consisted of a central stem (in 25 32-35 this specially receives the name "candlestick"), with 3 curved branches on either side, all elegantly wrought with cups of almond blossom, knobs, and flowers (lilies?)—3 of this series to each branch and 4 to the central stem. Upon the 6 branches and the central stem were 7 lamps from which the light issued. Connected with the candlestick were snuffers and snuff-dishes for the wicks—all of gold. The candlestick was formed from a talent of pure gold (ver 38). See **CANDLESTICK**.

(c) The description of the altar of incense occurs (30 1-10) for some unexplained reason or displacement out of the place where it might be expected, but this is no reason for throwing doubt (with some) upon its existence. It was a small altar, overlaid with gold, a cubit (18 in.) square, and 2 cubits (3 ft.) high, with 4 horns. On it was burned sweet-smelling incense. It had the usual golden rim, golden rings, and gold-covered staves. See **ALTAR OF INCENSE**.

**III. History.**—We may fix 1220 BC as the approximate date of the introduction of the tabernacle. It was set up at Sinai on the 1. **Removal** 1st day of the 1st month of the 2d from Sinai year (Ex 40 2.17), i.e. 14 days before the celebration of the Passover on the first anniversary of the exodus (see **CHRONOLOGY OF THE OT**, VII, VIII). When the people resumed their journey, the ark was wrapped in the veil which had served to isolate the most holy place (Nu 4 5). This and the two altars were carried upon the shoulders of the children of Kohath, a descendant of Levi, and were removed under the personal supervision of the high priest (Nu 3 31,32; 4 15). The rest of the dismembered structure was carried in six covered wagons, offered by the prince, each drawn by two oxen (Nu 7). Doubtless others were provided for the heavier materials (cf Keil). Before leaving Sinai the brazen altar had been dedicated, and utensils of gold and silver had been presented for use at the services. The tabernacle had been standing at Sinai during 50 days (Nu 10 11).

The journey lay along the "great and terrible wilderness" between Horeb in the heart of Arabia and Kadesh-barnea in the Negeb of Judah; of the 40 years occupied at Kadesh in the journey to Canaan, nearly 38 were spent at Kadesh, a fact not always clearly recognized. The tabernacle stood here during 37 years (one year being occupied in a punitive journey southward to the shore of the Red Sea). During this whole time the ordinary sacrifices were not offered (Am 5 25), though it is possible that the appropriate seasons were nevertheless marked in more than merely chronological fashion. Few incidents are recorded as to these years, and little mention is made of the tabernacle throughout the whole journey except that the ark of the covenant preceded the host when on the march (Nu 10 33-36). It is the unusual that is recorded; the daily aspect of the tabernacle and the part it played in the life of the people were among the things recurrent and familiar.

When, at last, the Jordan was crossed, the first consideration, presumably, was to find a place on

which to pitch the sacred tent, a place hitherto uninhabited and free from possible defilement by human graves. Such a place was found in the neighborhood of Jericho, and came to be known as Gilgal (Josh 4 19; 5 10; 9 6; 10 6,43). Gilgal, however, was always regarded as a temporary site. The tabernacle is not directly mentioned in connection with it. The question of a permanent location was the occasion of mutual jealousy among the tribes, and was at last settled by the removal of the tabernacle to Shiloh, in the territory of Ephraim, a place conveniently central for attendance of all adult males at the three yearly festivals, without the zone of war, and also of some strategic importance. During the lifetime of Joshua, therefore, the tabernacle was removed over the 20 miles, or less, which separated Shiloh among the hills from Gilgal in the lowlands (Josh 18 1; 19 51). While at Shiloh it seems to have acquired some accessories of a more permanent kind (1 S 1 9, etc), which obtained for it the name "temple" (1 9; 3 3).

During the period of the Judges the nation lost the fervor of its earlier years and was in imminent danger of apostasy. The daily serv-

**4. Destruction of Shiloh**—ices of the tabernacle were doubtless observed after a perfunctory manner, but they seem to have had little effect

upon the people, either to soften their manners or raise their morals. In the early days of Samuel war broke out afresh with the Philis. At a council of war the unprecedented proposal was made to fetch the ark of the covenant from Shiloh (1 S 4 1 ff). Accompanied by the two sons of Eli—Hophni and Phinehas—it arrived in the camp and was welcomed by a shout which was heard in the hostile camp. It was no longer Jeh but the material ark that was the hope of Israel, so low had the people fallen. Eli himself, at that time high priest, must at least have acquiesced in this superstition. It ended in disaster. The ark was taken by the Philis, its two guardians were slain, and Israel was helpless before its enemies. Though the Heb historians are silent about what followed, it is certain that Shiloh itself fell into the hands of the Philis. The very destruction of it accounts for the silence of the historians, for it would have been at the central sanctuary there, the center and home of what literary culture there was in Israel during this stormy period, that chronicles of events would be kept. Ps 78 60 ff no doubt has reference to this overthrow, and it is referred to in Jer 7 12. The tabernacle itself does not seem to have been taken by the Philis, as it is met with later at Nob.

For lack of a high priest of character, Samuel himself seems now to have become the head of religious worship.

### 5. Delocalization of Worship

It is possible that the tabernacle may have been again removed to Gilgal, as it was there that Samuel appointed Saul to meet him in order to offer burnt offerings and peace offerings. The ark, however, restored by the Philis, remained at Kiriath-jearim (1 S 7 1.2), while courts for ceremonial, civil, and criminal administration were held, not only at Gilgal, but at other places, as Beth-el, Mizpah and Ramah (1 S 7 15-17), places which acquired a quasi-ecclesiastical sanctity. This delocalization of the sanctuary was no doubt revolutionary, but it is partly explained by the fact that even in the tabernacle there was now no ark before which to burn incense. Of the half-dozen places bearing the name of Ramah, this, which was Samuel's home, was the one near to Hebron, where to this day the foundations of what may have been Samuel's sacred inclosure may be seen at the modern *Râmet-el-Khâlîl*.

We next hear of the tabernacle at Nob, with Ahimelech, a tool of Saul (probably the Ahijah of 1 S 14 3), as high priest (1 S 21 1 ff). This Nob was

### 6. Nob and Gibeon

4 miles to the N. of Jerus, and was more over a high place, 30 ft. higher than Zion. It does not follow that the tabernacle was placed at the top of the hill. Here it remained a few years, till after the massacre by Saul of all the priests at Nob save one, Abiathar (1 S 22 11 ff). Subsequently, possibly by Saul himself, it was removed to Gibeon (1 Ch 16 39; 21 29). Gibeon was 6 miles from Jerus, and 7 from Beth-el, and may have been chosen for its strategic advantage as well as for the fact that it was already inhabited by priests, and was Saul's ancestral city.

This removal by Saul, if he was the author of it, was recognized afterward by David as a thing done, with which he did not think it wise

### 7. Restoration of the Ark

to interfere (cf 1 Ch 16 40). On his capturing the fortress of Jebus (later Jerus), and building himself a "house" there, David prepared a place for the ark of God, and pitched a tent on Zion in imitation of the tabernacle at Gibeon (2 S 6 17 ff; 1 Ch 16 1). He must also have provided an altar, for we read of burnt offerings and peace offerings being made there. Meanwhile the ark had been brought from Kiriath-jearim, where it had lain so long; it was restored in the presence of a concourse of people representing the whole nation, the soldiery and civilians delivering it to the priests (2 S 6 1 ff). On this journey Uzzah was smitten for touching the ark. Arrived near Jerus, the ark was carried into the house of Obed-edom, a Levite, and remained there for 3 months. At the end of this time it was carried into David's tabernacle with all fitting solemnity and honor.

Hence it was that there were now two tabernacles, the original one with its altar at Gibeon, and the new one with the original ark in Jerus,

### 8. The Two Tabernacles

both under the protection of the king. However, were soon to be superseded by the building of a temple. The altar at Gibeon continued in use till the time of Solomon. Of all the actual material of the tabernacle, the ark alone remained unchanged in the temple. The tabernacle itself, with its sacred vessels, was brought up to Jerus, and was preserved, apparently, as a sacred relic in the temple (1 K 8 4). Thus, after a history of more than 200 years, the tabernacle ceases to appear in history.

**IV. Symbolism.**—Though the tabernacle was historically the predecessor of the later temples, as a matter of fact, the veil was the only item actually retained throughout the series of temples. Nevertheless it is the tabernacle rather than the temple which has provided a substructure for much NT teaching. All the well-known allusions of the writer to the He, e.g. in chs 9 and 10, are to the tabernacle, rather than to any later temple.

In general the tabernacle is the symbol of God's dwelling with His people (Ex 25 8; cf 1 K 8 27), an idea in process of realization in more and more perfect forms till it reaches its completion in the incarnation of the Word ("The Word became flesh,

and dwelt [Gr "tabernacled"] among us," Jn 1 14; cf 2 Cor 5 1), in the church collectively (2 Cor 6 16) and in the individual believer

### 1. NT References

(1 Cor 6 19) and finally in the eternal glory (Rev 2 13 ff). In the Ep. to the He, the *locus classicus* of the tabernacle in Christian thought, the idea is more cosmical—the tabernacle in its holy and most holy divisions representing the earthly and the heavenly spheres of Christ's activity. The OT was but a shadow of the eternal substance, an indication of the true ideal (He 8 5; 10 1). The tabernacle in which Christ ministered was a tabernacle which the Lord pitched, and not man (8 2). He is the high priest of "the greater and more perfect tabernacle" (9 11). "Christ entered not into a holy place made with hands, like in pattern to the true; but into heaven itself, now to appear before the face of God for us" (9 24). The symbolical significance of the tabernacle and its worship is not, however, confined to the Ep. to the He. It must be admitted that St. Paul does not give prominence to the tabernacle symbolism, and further, that his references are to things common to the tabernacle and the temple. But St. Paul speaks of "the laver of regeneration" (Tit 3 5 R.Vm), and of Christ, who "gave himself up for us, an offering and a sacrifice to God, for an odor of a sweet smell" (Eph 5 2). The significance which the synoptic writers give to the rending of the veil of the temple (Mt 27 51; Mk 15 38; Lk 23 45) shows how this symbolism entered deeply into their thought and was felt by them to have Divine attestation in this supernatural fact. The way into the holiest of all, as the writer to the He says, was now made manifest (9 8; 10 19.20).

The suggestion which underlies all such NT references is not only that Christ, in His human manifestation,

### 2. God's Dwelling with Man

was both tabernacle and priest, altar and sacrifice, but also, and still more, that God ever has His dwelling among men, veiled no doubt from the unbelieving and insincere, but always manifest and accessible to the faithful and devout. As we have a great high priest who is now passed into the heavens, there to appear in our behalf in the true tabernacle, so we ourselves have permission and encouragement to enter into the holiest place of all on earth by the blood of the everlasting covenant. Of the hopes embodied in these two planes of thought, the earthly tabernacle was the symbol, and contained the prospect and foretaste of the higher communion. It is this which has given the tabernacle such an abiding hold on the imagination and veneration of the Christian church in all lands and languages.

The symbolism of the various parts of the tabernacle furniture is tolerably obvious, and is considered under the different headings.

### 3. Symbol-Furniture

The ark of the covenant with its propitiatory was the symbol of God's gracious meeting with His people on the ground of atonement (cf Rom 3 25; see ARK OF THE COVENANT). The twelve cakes of shewbread denote the twelve tribes of Israel, and their presentation is at once an act of gratitude for that which is the support of life, and, symbolically, a dedication of the life thus supported; the candlestick speaks to the calling of Israel to be a people of light (cf Jesus in Mt 5 14-16); the rising incense symbolizes the act of prayer (cf Rev 5 8; 8 3).

**LITERATURE.**—See the arts. on "Tabernacle" and "Temple" in Smith's *DB*, *HDB*, *EB*, *The Temple BD*, etc; also the comms. on Exodus (the *Speaker's Pulpit Comm.*, Keil's, Lange's, etc); Bähr, *Symbolik d. Mosaischen Cultus*; Keil, *Archaeology*, I, 98 ff (ET); Westcott, essay on "The General Significance of the Tabernacle," in his *Hebrews*; Brown, *The Tabernacle* (1899); W. S. Caldecott, *The Tabernacle: Its History and Structure*. See arts. in this Encyclopaedia on the special parts of the tabernacle; and see also **TEMPLE**.

W. SHAW CALDECOTT  
JAMES ORR

## B. IN CRITICISM

- I. CONSERVATIVE AND CRITICAL VIEWS  
 II. ARGUMENTS IN SUPPORT OF THE CRITICAL THEORY EXAMINED
1. Not Stated That the Temple Was Constructed after the Pattern of the Tabernacle
  2. No Trace of the Tabernacle in Pre-Solomonic Times
  3. The Tabernacle Could Not Have Been Built as Exodus Describes
  4. Biblical Account Contains Marks of Its Unhistorical Character
  5. Preëxilic Prophets Knew Nothing of Levitical System of Which the Tabernacle Was Said to Be the Center.

## LITERATURE

**I. Conservative and Critical Views.**—The conservative view of Scripture finds (1) that the tabernacle was constructed by Moses in the wilderness of Sinai; (2) that it was fashioned according to a pattern shown to him in the Mount; (3) that it was designed to be and was the center of sacrificial worship for the tribes in the wilderness; and (4) that centuries later the Solomonic Temple was constructed after it as a model. The critical (higher) view of Scripture says, (1) that the tabernacle never existed except on paper; (2) that it was a pure creation of priestly imagination sketched after or during the exile; (3) that it was meant to be a miniature sanctuary on the model of Solomon's Temple; (4) that it was represented as having been built in the wilderness for the purpose of legitimating the newly published PC or Levitical ritual still preserved in the middle books of the Pent; and (5) that the description of the tabernacle furnished in P (Ex 25-31; 36-40; Nu 2 2:17; 5 1-4; 14 44) conflicts with that given in E (Ex 33 7-11), both as to its character and its location.

The principal grounds on which it is proposed to set aside the conservative and put in its place the critical theory are these:

**II. Arguments in Support of the Critical Theory Examined.**—(1) It is nowhere stated that Solomon's Temple was constructed after the pattern of the Mosaic tabernacle; hence it is reasonable to infer that the Mosaic tabernacle had no existence when or before the Solomonic Temple was built.

(2) No trace of the Mosaic tabernacle can be found in the pre-Solomonic period, whence it is clear that no such tabernacle existed.

(3) The Mosaic tabernacle could not have been produced as Ex describes, and accordingly the story must be relegated to the limbo of romance.

(4) The Bib. account of the Mosaic tabernacle bears internal marks of its completely unhistorical character.

(5) The preëxilic prophets knew nothing of the Levitical system of which the Mosaic tabernacle was the center, and hence the whole story must be set down as a sacred legend.

These assertions demand examination.

It is urged that *nowhere is it stated that Solomon's Temple was fashioned after the pattern of the Mosaic tabernacle.* Wellhausen thinks. (*GI*,

**1. First** ch i, 3, p. 44) that, had it been so, the **Alleged** narrators in K and Ch would have **Ground** said so. "At least," he writes, "one would have expected that in the report concerning the building of the new sanctuary, casual mention would have been made of the old." And so there was—in 1 K 8 4 and 2 Ch 5 5. Of course, it is contended that "the tent of meeting" referred to in these passages was not the Mosaic tabernacle of Ex 25, but simply a provisional shelter for the ark—though in P the Mosaic tabernacle bears the same designation (Ex 27 21). Conceding, however, for the sake of argument, that the tent of the historical books was not the Mosaic tabernacle of Ex, and that this is nowhere spoken

of as the model on which Solomon's Temple was constructed, does it necessarily follow that because the narrators in K and Ch did not expressly state that Solomon's Temple was built after the pattern of the Mosaic tabernacle, therefore the Mosaic tabernacle had no existence when the narrators wrote? If it does, then the same logic will demonstrate the non-existence of Solomon's Temple before the exile, because when the writer of P was describing the Mosaic tabernacle he made no mention whatever about its being a miniature copy of Solomon's Temple. A *reductio ad absurdum* like this disposes of the first of the five pillars upon which the new theory rests.

It is alleged that *no trace of the Mosaic tabernacle can be found in pre-Solomonic times.* On the

**2. Second** principle that silence about a person, **Alleged** thing or event does not prove the non- **Ground** existence of the person or thing or the non-occurrence of the event, this 2d argument might fairly be laid aside as irrelevant. Yet it will be more satisfactory to ask, if the assertion be true, why no trace of the tabernacle can be detected in the historical books in pre-Solomonic times. The answer is, that of course it is true, if the historical books be first "doctored," i.e. gone over and dressed to suit the theory, by removing from them every passage, sentence, clause and word that seems to indicate, presuppose or imply the existence of the tabernacle, and such passage, sentence, clause and word assigned to a late R who inserted it into the original text to give color to his theory, and support to his fiction that the Mosaic tabernacle and its services originated in the wilderness. Could this theory be established on independent grounds, i.e. by evidence derived from other historical documents, without tampering with the sacred narrative, something might be said for its plausibility. But every scholar knows that not a particle of evidence has ever been, or is likely ever to be, adduced in its support beyond what critics themselves manufacture in the way described.

That they do find traces of the Mosaic tabernacle in the historical books, they unconsciously and unintentionally allow by their efforts to explain such traces away, which moreover they can only do by denouncing these traces as spurious and subjecting them to a sort of surgical operation in order to excise them from the body of the text. But these so-called spurious traces are either true or they are not true. If they are true, whoever inserted them, then they attest the existence of the tabernacle, first at Shiloh, and afterward at Nob, later at Gibeon, and finally at Jerus; if they are not true, then some other things in the narrative must be written down as imagination, as, e.g. the conquest of the land, and its division among the tribes, the story of the altar on the E. of Jordan, the ministry of the youthful Samuel at Shiloh, and of Ahimelech at Nob.

(1) *The Mosaic tabernacle at Shiloh.*—That the structure at Shiloh (1 S 1 3.9.19.24; 2 11.12; 3 3) was the Mosaic tabernacle everything recorded about it shows. It contained the ark of God, called also the ark of the covenant of God and the ark of the covenant of Jeh, or more fully the ark of the covenant of Jeh of Hosts, names, esp. the last, which for the ark associated with the tabernacle were not unknown in the period of the wandering. It had likewise a priesthood and a sacrificial worship of three parts—offering sacrifice (in the forecourt), burning incense (in the holy place), and wearing an ephod (in the Holy of Holies)—which at least bore a close resemblance to the cultus of the tabernacle, and in point of fact claimed to have been handed down from Aaron. Then Elkanah's pious custom of going up yearly from

Ramathaim-zophim to Shiloh to worship and to sacrifice unto Jeh of Hosts suggests that in his day Shiloh was regarded as the central high place and that the law of the three yearly feasts (Ex 23 14; Lev 23 1-18; Dt 16 16) was not unknown, though perhaps only partially observed; while the statement about "the women who did service at the door of the tent of meeting" as clearly points back to the similar female institution in connection with the tabernacle (Ex 38 8). To these considerations it is objected (a) that the Shiloh sanctuary was not the Mosaic tabernacle, which was a portable tent, but a solid structure with posts and doors, and (b) that even if it was not a solid structure but a tent, it could be left at any moment without the ark, in which case it could not have been the Mosaic tabernacle of which the ark was an "inseparable companion"; while (c) if it was the ancient "dwelling" of Jeh, it could not have been made the dormitory of Samuel. But (a) while it need not be denied that the Shiloh sanctuary possessed posts and doors—Jer 7 12 seems to admit that it was a structure which might be laid in ruins—yet this does not warrant the conclusion that the Mosaic tabernacle had no existence in Shiloh. It is surely not impossible or even improbable that, when the tabernacle had obtained a permanent location at Shiloh, and that for nearly 400 years (cf above under A, III, 1, 8 and see CHRONOLOGY OF THE OT, VII, VIII), during the course of these centuries a porch with posts and doors may have been erected before the curtain that formed the entrance to the holy place, or that strong buildings may have been put up around it as houses for the priests and Levites, as treasure-chambers, and such like—thus causing it to present the appearance of a palace or house with the tabernacle proper in its interior. Then (b) as to the impossibility of the ark being taken from the tabernacle, as was done when it was captured by the Philis, there is no doubt that there were occasions when it was not only legitimate, but expressly commanded to separate the ark from the tabernacle, though the war with the Philis was not one. In Nu 10 33, it is distinctly stated that the ark, by itself, went before the people when they marched through the wilderness; and there is ground for thinking that during the Benjamite war the ark was with Divine sanction temporarily removed from Shiloh to Beth-el (Jgs 20 26,27) and, when the campaign closed, brought back again to Shiloh (21 12). (c) As for the notion that the Shiloh sanctuary could not have been the Mosaic tabernacle because Samuel is said to have slept in it beside the ark of God, it should be enough to reply that the narrative does not say or imply that Samuel had converted either the holy place or the most holy into a private bed-chamber, but merely that he lay down to sleep "in the temple of the Lord where the ark of God was," doubtless "in the court where cells were built for the priests and Levites to live in when serving at the sanctuary" (Keil). But even if it did mean that the youthful Samuel actually slept in the Holy of Holies, one fails to see how an abuse like that may not have occurred in a time so degenerate as that of Eli, or how, if it did, it would necessarily prove that the Shiloh shrine was not the Mosaic tabernacle.

(2) *The Mosaic tabernacle at Nob.*—That the sanctuary at Nob (1 S 21 1-6) was the Mosaic tabernacle may be inferred from the following circumstances: (a) that it had a high priest with 85 ordinary priests, a priest's ephod, and a table of shewbread; (b) that the eating of the shewbread was conditioned by the same law of ceremonial purity as prevailed in connection with the Mosaic tabernacle (Lev 15 18); and (c) that the Urim was employed there by the priest to ascertain the Divine will—all of which circumstances pertained to the Mosaic

tabernacle and to no other institution known among the Hebrews. If the statement (1 Ch 13 3) that the ark was not inquired at in the days of Saul calls for explanation, that explanation is obviously this, that during Saul's reign the ark was dissociated from the tabernacle, being lodged in the house of Abinadab at Kirjath-jearim, and was accordingly in large measure forgotten. The statement (1 S 14 18) that Saul in his war with the Philis commanded Ahijah, Eli's great-grandson, who was "the priest of the Lord in Shiloh, wearing an ephod" (ver 3) to fetch up the ark—if ver 18 should not rather be read according to the LXX, "Bring hither the ephod"—can only signify that on this particular occasion it was fetched from Kirjath-jearim at the end of 20 years and afterward returned thither. This, however, is not a likely supposition; and for the LXX reading it can be said that the phrase "Bring hither" was never used in connection with the ark; that the ark was never employed for ascertaining the Divine will, but the ephod was; and that the Heb text in ver 18 seems corrupt, the last clause reading "for the ark of God was at that day and the sons of Israel," which is not extremely intelligible.

(3) *The Mosaic tabernacle at Gibeon.*—The last mention of the Mosaic tabernacle occurs in connection with the building of Solomon's Temple (1 K 8 4; 2 Ch 1 3; 5 3), when it is stated that the ark of the covenant and the tent of meeting, and all the holy vessels that were in the tent were solemnly fetched up into the house which Solomon had built. That what is here called the tabernacle of the congregation, or the tent of meeting, was not the Mosaic tabernacle has been maintained on the following grounds: (a) that had it been so, David, when he fetched up the ark from Obed-edom's house, would not have pitched for it a tent in the city of David, but would have lodged it in Gibeon; (b) that had the Gibeon shrine been the Mosaic tabernacle it would not have been called as it is in K, "a great high place"; (c) that had the Gibeon shrine been the Mosaic tabernacle, Solomon would not have required to cast new vessels for his Temple, as he is reported to have done; and (d) that had the Gibeon shrine been the Mosaic tabernacle the brazen altar would not have been left behind at Gibeon but would also have been conveyed to Mt. Moriah.

But (a) if it was foolish and wrong for David not to lodge the ark in Gibeon, that would not make it certain that the Mosaic tabernacle was not at Gibeon. That it was either foolish or wrong, however, is not clear. David may have reckoned that if the house of Obed-edom had derived special blessing from the presence of the ark in it for three months, possibly it would be for the benefit of his (David's) house and kingdom to have the ark permanently in his capital. And in addition, David may have remembered that God had determined to choose out a place for His ark, and in answer to prayer David may have been directed to fetch the ark to Jerus. As good a supposition this, at any rate, as that of the critics.

(b) That the Gibeon shrine should have been styled "the great high place" (1 K 3 4) is hardly astonishing, when one calls to mind that it was the central sanctuary, as being the seat of the Mosaic tabernacle with its brazen altar. And may not the designation "high place," or *bāmāh*, have been affixed to it just because, through want of its altar, it had dwindled down into a mere shadow of the true sanctuary and become similar to the other "high places" or *bāmōth*?

(c) The casting of new vessels for Solomon's Temple needs no other explanation than this, that the new house was at least twice as spacious as the old, and that in any case it was fitting that the new house should have new furniture.

(d) That the brazen altar would not have been left behind at Gibeon when the Mosaic tabernacle was removed, may be met by the demand for proof that it was actually left behind. That it was left behind is a pure conjecture. That it was transplanted to Jerus and along with the other

tabernacle utensils laid up in a side chamber of the temple is as likely an assumption as any other (see 1 K 8 4).

It is maintained that the *Mosaic tabernacle could not have been produced as Ex describes*: (1) that the time was too short, (2) that the

**3. Third Alleged Ground** Israelites were too little qualified, and (3) that the materials at their disposal were too scanty for the construction of so splendid a building

as the Mosaic tabernacle. But (1) does any intelligent person believe that 9 months was too short a time for 600,000 able-bodied men, to say nothing of their women and children, to build a wooden house 30 cubits long, 10 high and 10 broad, with not as many articles in it as a well-to-do artisan's kitchen oftentimes contains? (2) Is it at all likely that they were so ill-qualified for the work as the objection asserts? The notion that the Israelites were a horde of savages or simply a tribe of wandering nomads does not accord with fact. They had been bondmen, it is true, in the land of Ham; but they and their fathers had lived there for 400 years; and it is simply incredible, as even Knobel puts it, "that they should not have learnt something of the mechanical arts." One would rather be disposed to hold that they must have had among them at the date of the Exodus a considerable number of skilled artisans. At least, archaeology has shown that if the escaped bondmen knew nothing of the arts and sciences, it was not because their quondam masters had not been able to instruct them. The monuments offer silent witness that every art required by the manufacturers existed at the moment in Egypt, as e.g. the arts of metal-working, wood-carving, leather-making, weaving and spinning. And surely no one will contend that the magnificent works of art, the temples and tombs, palaces and pyramids, that are the world's wonder today, were the production always and exclusively of native Egypt, and never of Heb thought and labor! Nor (3) is the reasoning good, that whatever the Israelites might have been able to do in Egypt where abundant materials lay to hand, they were little likely to excel in handicrafts of any sort in a wilderness where such materials were wanting. Even Knobel could reply to this, that as the Israelites when they escaped from Egypt were not a horde of savages, so neither were they a tribe of beggars; that they had not entered on their expedition in the wilderness without preparation, or without taking with them their most valuable articles; that the quantities of gold, silver and precious stones employed in the building of the tabernacle were but trifles in comparison with other quantities of the same that have been found in possession of ancient oriental peoples; that a large portion of what was contributed had probably been obtained by despoiling the Egyptians before escaping from their toils and plundering the Amalekites whom they soon after defeated at Rephidim, and who, in all likelihood, at least if one may judge from the subsequent example of the Midianites, had come to the field of war bedecked with jewels and gold; and that the acacia wood, the linen, the blue, the purple and the scarlet, with the goats', rams', and seal-skins might all have been found and prepared in the wilderness (cf Kurtz, *Geschichte des alten Bundes*, II, § 53). In short, so decisively has this argument, derived from the supposed deficiency of culture and resources on the part of the Israelites, been disposed of by writers of by no means too conservative proclivities, that one feels surprised to find it called up again by Benzinger in *EB* to do duty in support of the unhistorical character of the tabernacle narrative in Ex.

The Bib. account of the Mosaic tabernacle, it is further contended, bears internal marks of its completely unhistorical character, as e.g.

**4. Fourth Alleged Ground** (1) that it represents the tabernacle as having been constructed on a model which had been supernaturally shown to Moses; (2) that it habitually

speaks of the south, north, and west sides of the tabernacle although no preceding order had been issued that the tent should be so placed; (3) that the brazen altar is described as made of timber overlaid with brass, upon which a huge fire constantly burned; (4) that, the tabernacle is depicted, not as a mere provisional shelter for the ark upon the march, but "as the only legitimate sanctuary for the church of the twelve tribes before Solomon"; and (5) that the description of the tabernacle furnished in P (Ex 25-31; 36-40; Nu 2 2.17; 5 1-4; 14 44) conflicts with that given in E (Ex 33 7-11), both as to its character and its location.

But (1) why should the story of the tabernacle be a fiction, because Moses is reported to have made it according to a pattern showed to him in the Mount (Ex 25 40 [Heb 8 5])? No person says that the Temple of Solomon was a fiction, because David claimed that the pattern of it given to Solomon had been communicated to him (David) by Divine inspiration (1 Ch 28 19). Every critic also knows that Ezekiel wrote the book that goes by his name. Yet Ezekiel asserts that the temple described by him was beheld by him in a vision. Unless therefore the supernatural is ruled out of history altogether, it is open to reply that God could just as easily have revealed to Moses the pattern of the tabernacle as He afterward exhibited to Ezekiel the model of his temple. And even if God showed nothing to either one prophet or the other, the fact that Moses says he saw the pattern of the tabernacle no more proves that he did not write the account of it, than Ezekiel's stating that he beheld the model of his temple attests that Ezekiel never penned the description of it. The same argument that proves Moses did not write about the tabernacle also proves that Ezekiel could not have written about the vision-temple. Should it be urged that as Ezekiel's temple was purely visionary so also was Moses' tabernacle, the argument comes with small consistency and less force from those who say that Ezekiel's vision-temple was the model of a real temple that should afterward be built; since if Ezekiel's vision-temple was (or should have been, according to the critics) converted into a material sanctuary, no valid reason can be adduced why Moses' vision-tabernacle should not also have been translated into an actual building.

(2) How the fact that the tabernacle had three sides, south, north and west, shows it could not have been fashioned by Moses, is one of those mysteries which it takes a critical mind to understand. One naturally presumes that the tabernacle must have been located somewhere and oriented somehow; and, if it had four sides, it would assuredly suit as well to set them toward the four quarters of heaven as in any other way. But in so depicting the tabernacle, say the critics, the fiction writers who invented the story were actuated by a deep-laid design to make the Mosaic tabernacle look like the Temple of Solomon. Quite a harmless design, if it was really entertained! But the Books of K and Ch will be searched in vain for any indication that the Temple foundations were set to the four quarters of heaven. It is true that the 12 oxen who supported the molten sea in Solomon's Temple were so placed—4 looking to the N., 4 to the S., 4 to the E., and 4 to the W. (1 K 7 25); but this does not necessarily warrant the inference that the sides of the Temple were so placed. Hence on the well-known principle of modern criticism, that when a thing is not mentioned by a writer the thing does not exist, seeing that nothing is recorded about how the temple was placed, ought it not to be concluded that the whole story about the Temple is a myth?

(3) As to the absurdity of representing a large fire as constantly burning upon a wooden altar

overlaid with a thin plate of brass, this would certainly have been all that the critics say—a fatal objection to receiving the story of the tabernacle as true. But if the story was invented, surely the inventor might have given Moses and his two skilled artisans, Bezalel and Oholiab, some credit for common sense, and not have made them do, or propose to do, anything so stupid as to try to keep a large fire burning upon an altar of wood. This certainly they did not do. An examination of Ex 27 1-8; 38 1-7 makes it clear that the altar proper upon which "the strong fire" burned was the earth or stone-filled (Ex 20 24 f) hollow which the wooden and brass frame enclosed.

(4) The fourth note of fancy—what Wellhausen calls "the chief matter"—that the tabernacle was designed for a central sanctuary to the church of the Twelve Tribes before the days of Solomon, but never really served in this capacity—is partly true and partly untrue. That it was meant to be a central sanctuary, until Jeh should select for Himself a place of permanent habitation, which He did in the days of Solomon, is exactly the impression a candid reader derives from Ex, and it is gratifying to learn from so competent a critic as Wellhausen that this impression is correct. But that it really never served as a central sanctuary, it is impossible to admit, after having traced its existence from the days of Joshua onward to those of Solomon. That occasionally altars were erected and sacrifices offered at other places than the tabernacle—as by Gideon at Ophrah (Jgs 6 24-27) and by Samuel at Ramah (1 S 7 17)—is no proof that the tabernacle was not the central sanctuary. If it is, then by parity of reasoning the altar in Mt. Ebal (Dt 27 5) should prove that Jerus was not intended as a central sanctuary. But, if alongside of the Temple in Jerus, an altar in Ebal could be commanded, then also alongside of the tabernacle it might be legitimate to erect an altar and offer sacrifice for special needs. And exactly this is what was done. While the tabernacle was appointed for a central sanctuary the earlier legislation was not revoked: "An altar of earth thou shalt make unto me, and shalt sacrifice thereon thy burnt-offerings, and thy peace-offerings, thy sheep, and thine oxen: in every place where I record my name I will come unto thee and I will bless thee" (Ex 20 24). It was still legitimate to offer sacrifice in any spot where Jeh was pleased to manifest Himself to His people. And even though it had not been, the existence of local shrines alongside of the tabernacle would no more warrant the conclusion that the tabernacle was never built than the failure of the Christian church to keep the Golden Rule would certify that the Sermon on the Mount was never preached.

(5) With regard to the supposed want of harmony between the two descriptions of the tabernacle in P and E, much depends on whether the structures referred to in these documents were the same or different. (a) If different, i.e. if the tent in E (Ex 33 7-11) was Moses' tent (Kurtz, Keil, Kallsch, Ewald and others), or a preliminary tent erected by Moses (Hävernick, Lange, Kennedy, and A [I, 1], above), or possessed by the people from their forefathers (von Gerlach, Benzinger in *EB*), no reason can be found why the two descriptions should not have varied as to both the character of the tent and its location. The tent in E, which according to the supposition was purely provisional, a temporary sanctuary, may well have been a simple structure and pitched outside the camp; while the tent in P could just as easily have been an elaborate fabric with an ark, a priesthood and a complex sacrificial ritual and located in the midst of the camp. In this case no ground can arise for suggesting that they were contradictory of one another, or that P's tent was a fiction, a paper-tabernacle, while E's tent was a reality and the only tabernacle that ever existed in Israel. But (b) if on the other hand the tent in E was the same as the tent in P (Calvin, Mead in Lange, König, Eerdmans, Valetton and others), then the question may arise whether

or not any contradiction existed between them, and, if such contradiction did exist, whether this justifies the inference that P's tent was unhistorical, i.e. never took shape except in the writer's imagination.

That the tent in E was not P's Mosaic tabernacle has been argued on the following grounds: (a) that the Mosaic tabernacle (assuming it to have been a reality and not a fiction) was not yet made; so that E's tent must have been either the tent of Moses or a provisional tent; (b) that nothing is said about a body of priests and Levites with an ark and a sacrificial ritual in connection with E's tent, but only of a non-Levitical attendant Joshua, and (c) that it was situated outside the camp, whereas P's tabernacle is always represented as in the midst of the camp.

The first of these grounds largely disappears when Ex 33 7 is read as in RV: "Now Moses used to take the tent and to pitch it without the camp." The verbs, being in the imperfect, point to Moses' practice (Driver, *Intro and Heb Tenses*; cf Ewald, *Syntax*, 348), which again may refer either to the past or to the future, either to what Moses was in the habit of doing with his own or the preliminary tent, or what he was to do with the tent about to be constructed. Which interpretation is the right one must be determined by the prior question which tent is intended. Against the idea of E's tent being Moses' private domicile stands the difficulty of seeing why it was not called *his* tent instead of *the* tent, and why Moses should be represented as never going into it except to hold communion with Jeh. If it was a provisional tent, struck up by Moses, why was no mention of its construction made? And if it was a sort of national heirloom come down from the forefathers of Israel, why does the narrative contain not the slightest intimation of any such thing?

On the other hand if E's tent was the same as P's, the narrative does not require to be broken up; and Ex 33 7-11 quite naturally falls into its place as an explanation of how the promises of vs 3 and 5 were carried out (see *infra*).

The second supposed proof that E's tent was not P's but an earlier one, viz. that P's had a body of priests and Levites, an ark and a complex ritual, while E's had only Joshua as attendant and made no mention of ark, priests or sacrifices, loses force, unless it can be shown that there was absolute necessity that in this paragraph a full description of the tabernacle should be given. But obviously no such necessity existed, the object of the writer having been as above explained. Driver, after Wellhausen (*GJ*, 387), conjectures that in E's original document Ex 33 7-11 may have been preceded "by an account of the construction of the Tent of Meeting and of the ark," and that "when the narrative was combined with that of P this part of it (being superfluous by the side of chs 25-35) was probably omitted." As this however is only a conjecture, it is of no more (probably of less) value than the opinion that chs 25-35 including 33 7-11 proceeded from the same pen. The important contribution to the interpretation of the passage is that the absence from the paragraph relating to E's tent of the ark, priests and sacrifices is no valid proof that E's tent was not the Mosaic tabernacle.

The third argument against their identity is their different location—E's outside and P's inside the camp. But it may be argued (a) that the tr in RV distinctly relieves this difficulty. For if Moses used to take and pitch the tabernacle outside the camp, the natural implication is that the tabernacle was often, perhaps usually, inside the camp, as in P, and only from time to time pitched outside the camp, when Jeh was displeased with the people (Eerdmans, Valetton). Or (2) that "outside the camp" may signify away, at an equal distance from all the four camps ("over against the tent of meeting"—in AV "far off," after Josh 3 4—were the various tribes with their standards, i.e. the four camps, to be pitched; Nu 2 2); so that the tabernacle might easily be in the midst of all the camps and yet "outside" and "far off" from each camp separately, thus requiring every individual who sought the Lord to go out from his camp unto the tabernacle. Nu 11 26-30 may perhaps shed light upon the question. There it is stated that "there remained two men in the camp [who] had not gone out with Moses unto the Tent," and that Moses and the elders after leaving the tent, "gat [them] into the camp." Either the tent at this time was in the center of the square, around which the four camps were stationed, or it was outside. If it was outside, then the first of the foregoing explanations will hold good; if it was inside the camp, then the second suggestion must be adopted, viz. that while the camps were round about the tabernacle, the tabernacle was outside each camp. "Although the tabernacle stood in the midst of the camp, yet it was practically separated from the tents of the tribes by an open space and by the encampment of the Levites" (*Pulpit Comm.*, in loc.; cf Keil, in loc.). When one calls to mind that the tabernacle was separated from each side of the square probably, as in Josh 3 4, by 2,000 cubits (at 19-25 in. each = about  $\frac{1}{2}$  of a mile), one has small difficulty in understanding how the tabernacle could be both outside the several camps and inside them all; how the two promises in Ex 33 (AV)—"I will not go up in the midst of thee" (ver 3) and "I will come up into



the midst of thee" (ver 5)—might be fulfilled; how Moses and the elders could go out from the camp (i.e. their several camps) to the tabernacle and after leaving the tabernacle return to the camp (i.e. their several camps); and how no insuperable difficulty in the shape of an insoluble contradiction exists between E's account and P's.

That the preëxilic prophets knew nothing about the Levitical system of which the tabernacle was the center is regarded as perhaps the strongest proof that the tabernacle had no existence in the wilderness and indeed never existed at all except on paper. The assertion about the ignorance of the preëxilic prophets as to the sacrificial system of the PC has been so often made that it has come to be a "commonplace" and "stock-phrase" of modern criticism. In particular, Amos in the 8th cent. BC (5 25.26) and Jeremiah in the 7th cent. BC (7 21-23) are quoted as having publicly taught that no such sacrificial ritual as the tabernacle implied had been promulgated in the wilderness. But, if these prophets were aware that the Levitical Law had not been given by Moses, one would like to know, (1) how this interpretation of their language had been so long in being discovered; (2) how the critics themselves are not unanimous in accepting this interpretation—which they are not; (3) how Amos could represent Jeh as saying "I hate, I despise your feasts, and I will take no delight in your solemn assemblies. Yea, though ye offer me your burnt-offerings and meal-offerings, I will not accept them; neither will I regard the peace-offerings of your fat beasts" (5 21.22), if Jeh had never accepted and never enjoined them; (4) how Jeremiah could have been a party to putting forward Dt as a work of Moses if he knew that Jeh had never commanded sacrifices to be offered, which Dt does; and (5) how Jeremiah could have blamed Judah for committing spiritual adultery if Jeh had never ordered the people to offer sacrifice.

In reply to (1) it will scarcely do to answer that all previous interpreters of Am and Jer had failed to read the prophets' words as they stand (Am 5 25.26; Jer 7 22), because the question would then arise why the middle books of the Pent should not also be read as they stand, as e.g. when they say, "The Lord spake unto Moses," and again "These [the legislative contents of the middle books] are the commandments, which Jeh commanded Moses for the children of Israel in mount Sinai" (Lev 27 34). As for (2) it is conveniently forgotten that Bohlen (*Intro to Gen*, I, 277) admitted that some of the Pent "might possibly have originated in the time of Moses," and when quoting Jer 7 22 never dreamt of putting forward an explanation different from the orthodox rendering of the same, and certainly did not cite it as a proof that the Law had no existence prior to the exile; that De Wette in his *Einleitung* (261, 262, 8th ed) stated that "the holy laws and institutions of the theocratic people had for their author Moses, who in giving them stood under Divine guidance"; that Knobel (*Die Bücher Ex und Lev*, xxii) explicitly declared that Moses must be regarded not only as the liberator and founder of his people, but also the originator of the peculiar Israelitish constitution and lawgiving, at least in its fundamental elements; that Ewald (*Die Propheten*, II, 123) regarded Jer 7 22 as making no announcement about the origin of the sacrificial cultus; and that Bleek (*Intro to the OT*) forgot to read the modern critical interpretation into the words of Amos and Jeremiah for the simple reason that to have done so would have stultified his well-known view that many of the laws of the middle books of the Pent are of Mosaic origin. Nor is the difficulty (3) removed by holding that, if prior to the days of Amos Jeh did accept the burnt offerings

and meal offerings of Israel, these were not sacrifices that had been appointed in the wilderness, because Jeh Himself appears to intimate (Am 5 25.26) that no such sacrifices or offerings had been made during the whole 40 years' wandering. Had this been the case, it is not easy to see why the post-exilic authors of the PC should have asserted the contrary, should have represented sacrifices as having been offered in the wilderness, as they have done (see Nu 16, 18). The obvious import of Jeh's language is either that the sacrificial worship which He had commanded had been largely neglected by the people, or that it had been so heartless and formal that it was no true worship at all—their real worship being given to their idols—and that as certainly as the idolaters in the wilderness were excluded from Canaan, so the idolaters in Amos' day, unless they repented, would be carried away into exile. As to (4) Jeremiah's action in putting forward or helping to put forward Dt as a work of Moses when he knew that it represented Jeh as having commanded sacrifices to be offered both in the wilderness and in Canaan (Dt 12 6.11.13), and must have been aware as well that JE had represented Jeh as commanding sacrifice at Sinai (Ex 20 24.25), no explanation can be offered that will clear the prophet from the charge of duplicity and insincerity, or prevent his classification with the very men who were a grief of mind to him and against whom a large part of his life was spent in contending, viz. the prophets that prophesied lies in the name of God. Nor does it mend matters to suggest (Cheyne) that when Jeremiah perceived that Dt, though floated into publicity under high patronage, did not take hold, he changed his mind, because in the first place if Jeremiah did so, he should, like an honest man, have washed his hands clear of Dt, which he did not; and in the second place, because had he done so he could not have been "the iron pillar and brazen wall" which Jeh had intended him to be and indeed had promised to make him against the princes, priests and people of the land (1 18). And, still further, (5) it passes comprehension how, if Jeh never commanded His people to offer sacrifice to Him, Jeremiah could have represented Jeh as enjoining him to pronounce a curse upon the inhabitants of Jerus because they transgressed the words of Jeh's covenant, which He had made with their fathers in the day when He brought them out of the land of Egypt, by running after other gods to serve them, setting up altars and burning incense unto Baal and even working lewdness in Jeh's house (Jer 11 1-15). It is urged in answer to this, that the offence complained of was not that the men of Judah did not offer sacrifices to Jeh, but that they offered them to Baal and polluted His temple with heathen rites—that what Jeh demanded from His worshippers was not the offering of sacrifice, but obedience to the moral law conjoined with abstinence from idolatry. But in that case, what was the use of a temple at all? And why should Jeh speak of it as "mine house," if sacrifices were not required to be offered in it (cf on this Kittel, *The Scientific Study of the OT*, 218)? Why idolatrous sacrifices were denounced was not merely because they were wrong in themselves, but also because they had supplanted the true sacrificial worship of Jeh. As already stated, it is not easy to perceive how Jeremiah could have said that Jeh had never commanded sacrifices to be offered to Him, when he (Jeremiah) must have known that the Book of the Covenant in JE (Ex 20 24.25) represented Jeh as expressly enjoining them. Had Jeremiah not read the Book of the Covenant with sufficient care? This is hardly likely in so earnest a prophet. Or will it be lawful to suggest that Jeremiah knew the

Book of the Covenant to be a fiction and the assumption of Divine authority for its enactments to be merely a rhetorical device? In this case his words might be true; only one cannot help regretting that he did not distinctly state that in his judgment the Book of the Covenant was a fraud.

It may now be added in confirmation of the preceding, that the various references to a tabernacle in the NT appear at least to imply that in the 1st Christian cent. the historicity of the Mosaic tabernacle was generally accepted. These references are Peter's exclamation on the Mount of Transfiguration (Mt 17 4; Mk 9 5; Lk 9 33); Stephen's statement in the council (Acts 7 44); the affirmations in He (chs 8, 9); and the voice which John heard out of heaven (Rev 21 3). It may be admitted that taken separately or unitedly these utterances do not amount to a conclusive demonstration that the tabernacle actually existed in the wilderness; but read in the light of OT declarations that such a tabernacle did exist, they have the force of a confirmation. If the language of Peter and that of John may fairly enough be regarded as figurative, even then their symbolism suggests, as its basis, what Stephen and the writer to the He affirm to have been a fact, viz. that their "fathers had the tabernacle . . . in the wilderness," and that, under the first covenant, "there was a tabernacle prepared."

LITERATURE.—I, critical: De Wette, *Beiträge*; von Bohlen, *Genesis*; Georg, *Jüdische Feste*; Reuss, *Geschichte der heiligen Schriften des AT*; Graf, *de Templo Sionensi*; Kuenen, *The Religion of Israel*; Wellhausen, *Prolegomena zur Geschichte Israels*; HDB and EB, arts. "Tabernacle." II, conservative: Bredenkamp, *Gesetz und Propheten*; Kurtz, *Geschichte des alten Bundes*; Hävernick, *Einführung*; Hengstenberg, *Egypt and the Books of Moses*; Riehm, *Handwörterbuch*, and Herzog, *RE* (ed 1; ed 3 is "critical"), arts. "Stiftshütte"; Baxter, *Sanctuary and Sacrifice*; Bissell, *The Pentateuch: Its Origin and Structure*; Orr, *The Problem of the OT*; Whitelaw, *OT Critics*.

T. WHITELAW

**TABERNACLE OF TESTIMONY (WITNESS)** (Nu 9 15; 2 Ch 24 6, RV "the tent of the testimony"). See **TABERNACLE**.

**TABERNACLES, FEAST OF.** See **FEASTS AND FASTS, I, A, 3.**

**TABITHA**, tab'i-tha (Ταβειθά, *Tabethá*). See **DORCAS.**

**TABLE:** "Table" is derived from the Lat *tabula*, meaning primarily "a board," but with a great variety of other significances, of which "writing-tablet" is the most important for the Bib. use of "table." So in Eng. "table" meant at first "any surface" and, in particular, "a surface for writing," and further specialization was needed before "table" became the name of the familiar article of furniture ("object with a horizontal surface"), a meaning not possessed by *tabula* in Lat. After this specialization "table" in the sense of "a surface for writing" was replaced in later Eng. by the diminutive form "tablet." But "surface for writing" was still a common meaning of "table," and in this sense it represents טָבֵל, *lūḥ* (Ex 24 12, etc), a word of uncertain origin, πλάξ, *pláx*, "something flat" (2 Cor 3 3; He 9 4), δέλτος, *déltos*, "a writing tablet" (1 Macc 8 22; 14 18.27.48), or πινακίδιον, *pinakídion*, "writing tablet" (Lk 1 63—a rather unusual word). ARV has kept the word in the familiar combination "tables of stone" (Ex 24 12, etc), but elsewhere (Prov 3 3; 7 3; Isa 30 8; Jer 17 1; Hab 2 2; Lk 1 63) has replaced "table" by "tablet," a change made by ERV only in Isa 30 8; Lk 1 63. See **TABLET**.

The table as an article of furniture is שֻׁלְחָן, *shulḥān*, in the Heb and τράπεζα, *trápeza*, in the Gr. The only exceptions are Cant 1 12, מֵשָׁבֵט, *mēšabbh*, "something round," perhaps a "round table," perhaps a "cushion," perhaps a "festal procession," and Mk 7 4, AV κλίνη, *klínē*, "couch" (so RV), while Jn 13 28 and Jn 12 2, AV "at the table," and Tob 7 8, AV "on the table," represent only the general sense of the original. Of the two regu-

lar words, *shulḥān* is properly "a piece of hide," and so "a leather mat," placed on the ground at meal time, but the word came to mean any "table," however elaborate (e.g. Ex 25 23-30). *Trapeza* means "having four feet."

2 K 4 10 seems to indicate that a table was a necessary article in even the simpler rooms. Curiously enough, however, apart from the table of shewbread there is no reference in the Bible to the form or construction of tables, but the simpler tables in Pal of the present day are very much lower than ours. The modern "tables of the money changers" (Mk 11 15 and ||s) are small square trays on stands, and they doubtless had the same form in NT times. See **SHEWBREAD, TABLE OF; MONEY-CHANGERS.**

To eat at a king's table (2 S 9 7, etc) is naturally to enjoy a position of great honor, and the privilege is made by Christ typical of the highest reward (Lk 22 30). Usually "to eat at one's table" is meant quite literally, but in 1 K 18 19; Neh 5 17 (cf 1 K 10 5) it probably means "be fed at one's expense." On the other hand, the misery of eating the leavings of a table (Jgs 1 7; Mk 7 28; Lk 16 21) needs no comment. The phrase "table of the Lord [Jeh]" in Mal 1 7.12 AV (cf Ezk 41 22; 44 16—Ezk 39 20 is quite different) means "the table [altar] set before the Lord," but the same phrase in 1 Cor 10 21 is used in a different sense and the origin of its use by St. Paul is obscure. Doubtless the language, if not the meaning, of Mal had its influence and may very well have been suggested to St. Paul as he wrote 1 Cor 10 18. On the other hand, light may be thrown on the passage by such a papyrus fragment as "Chareimon invites you to dine at the table [*klínē*] of the lord Serapis," a formal invitation to an idol-banquet (1 Cor 8 10; Pap. Oxyr. i.110; cf iii.523). This would explain St. Paul's "table of demons"—a phrase familiar to the Corinthians—and he wrote "table of the Lord" to correspond (cf, however, *Pirkē 'Abhōth*, iii.4). "Table at which the Lord is Host," at any rate, is the meaning of the phrase. On the whole passage see the comms., esp. that of Lietzmann (fullest references). Probably Lk 22 30 has no bearing on 1 Cor 10 21. The meaning of Ps 69 22 (quoted in Rom 11 9), "Let their table before them become a snare," is very obscure ('let them be attacked while deadened in revelings?'), and perhaps was left intentionally vague.

BURTON SCOTT EASTON

**TABLE OF NATIONS:**

1. The Table and Its Object
2. What It Includes and Excludes
3. Order of the Three Races
4. Extent of Each
5. Sons of Japheth
6. Sons and Descendants of Ham
7. Further Descendants of Ham
8. Sons of Shem
9. Further Descendants of Shem
10. Value of Table and Its Historical Notes
11. Further Arguments for Early Date of Table

This is the expression frequently used to indicate "the generations of the sons of Noah" contained in Gen 10. These occupy the whole

1. The chapter, and are supplemented by the Table and first 9 verses of ch 11, which explain Its Object how it came about that there were so many languages in the world as known to the Hebrews. The remainder of ch 11 traces the descent of Abram, and repeats a portion of the information contained in ch 10 on that account only. The whole is seemingly intended to lead up to the patriarch's birth.

Noah and his family being the only persons left alive after the Flood, the Table naturally begins with them, and it is from his three sons, Shem, Ham and Japheth, that the inhabitants of the earth,

as known to the Hebrews, were descended. All others—the Mongolians of the Far East and Japan, the American Indians, both North and South, the natives of Australia Includes and New Zealand—were naturally and Excludes omitted from the list. It may, of course, be argued that all the nations not regarded as descended from Shem and Japheth might be included among the descendants of Ham; but apart from the fact that this would give to Ham far more than his due share of the human race, it would class the Egyptians and Canaanites with the Mongolians, Indians, etc, which seems improbable. "The Table of Nations," in fact, excludes the races of which the Sem East was in ignorance, and which could not, therefore, be given according to their lands, tongues, families, and nations (Gen 10 5.20.31).

Notwithstanding that the sons of Noah are here (ver 1) and elsewhere mentioned in the order Shem, Ham and Japheth (5 32; 6 10), and Ham was apparently the youngest (see HAM), the Table begins (ver 2) with Japheth, enumerates then the descendants of Ham (ver 6), and finishes with those of Shem (ver 21). This order in all probability indicates the importance of each race in the eyes of the Hebrews, who as Semites were naturally interested most in the descendants of Shem with whom the list ends. This enabled the compiler to continue the enumeration of Shem's descendants in 11 12 immediately after the verses dealing with the building of the Tower of Babel and the Confusion of Tongues.

The numbers of the descendants of each son of Noah, however, probably bear witness to the compiler's knowledge, rather than their individual importance in his eyes. Thus the more remote and less known race of Japheth is credited with 14 descendants only (7 sons and 7 grandsons), while Ham has no less than 29

descendants (4 sons, 23 grandsons, and 2 great-grandsons), and Shem the same (5 sons, 5 grandsons, 1 great-grandson, and 20 remoter descendants to the 6th generation). Many of the descendants of Shem and Ham, however, are just as obscure as the descendants of Japheth. How far the relationship to the individual sons of Noah is to be taken literally is uncertain. The earlier names are undoubtedly those of nations, while afterward we have, possibly, merely tribes, and in ch 11 the list develops into a genealogical list of individuals.

It is difficult to trace a clear system in the enumeration of the names in the Table. In the immediate descendants of Japheth (10 2), Gomer, Magog, Tubal and Mesech, Japheth we have the principal nations of Asia Minor, but Madai stands for the Medes on the extreme E., and Javan (the Ionians) for the Greeks (? and Romans) on the extreme W. (unless the Greeks of Asia Minor were meant). Gomer's descendants apparently located themselves northward of this tract, while the sons of Javan extended themselves along the Mediterranean coast-lands westward, Tarshish standing, apparently, for Spain, Kittim being the Cyprians, and Rodanim the Rhodians.

Coming to the immediate descendants of Ham (10 6), the writer begins with those on the S. and then goes northward in the following order: Cush or Ethiopia, Mizraim or Egypt, Phut (better Put, RV) by the Red Sea, and lastly Canaan—the Holy Land—afterward occupied by the Israelites. The sons of Cush, which follow (10 7), are apparently nationalities of the Arabian coast, where Egypt influence was predominant. These, with the sons of Raamah, embrace the interior of Africa as known to the Hebrews, and the Arabian tract as far as Canaan, its extreme northern boundary. The reference to Babylonia (Nimrod) may be regarded as following not unnaturally here, and prominence is given to the district on account of its importance and romantic history from exceedingly early times. Nevertheless, this portion (10 8-12) reads like an

interpolation, as it not only records the foundation of the cities of Babylonia, but those of Assyria as well—the country mentioned lower down (ver 22) among the children of Shem.

The text then goes back to the W. again, and enumerates the sons of Mizraim or Egypt (10 13), mostly located on the southeastern and eastern shores of the Mediterranean. These include the "Libyans in the narrowest sense" (Lehabim), two districts regarded as Egypt (Naph-tuhim and Pathrusim), the Casluhim

from whom came the Philistines, and the Caphtorim, probably not the Cappadocians of the Tgs, but the island of Crete, "because such a large island ought not to be wanting" (Dillmann). The more important settlements in the Canaanitish sphere of influence are referred to as the sons of Canaan (10 15)—Sidon, Heth (the Hittites), the Jebusites (who were in occupation of Jerus when the Israelites took it), the Amorites (whom Abraham found in Canaan), and others. Among the sons of Canaan are, likewise, the Girgashites, the Arkites and Sinites near Lebanon, the Arvadites of the coast, and the Hamathites, in whose capital, Hamath, many hieroglyphic inscriptions regarded as records of the Hittites or people of Heth have been found. It is possibly to this occupation of more or less outlying positions that the "spreading abroad" of the families of the Canaanites (10 18) refers. In 10 19 the writer has been careful to indicate "the border of the Canaanites," that being of importance in view of the historical narrative which was to follow; and here he was evidently on familiar ground.

In his final section—the nations descended from Shem (10 21)—the compiler again begins with the farthest situated—the Elamites—after which we have Asshur (Assyria), to the N.W.; Arpachshad (? the Chaldaeans), to the W.; Lud (Lydia), N.W. of Assyria; and Aram (the Aramaean states), S. of Lud and W. of Assyria. The tribes or states mentioned as the sons of Aram (Uz, Hul, Gether and Mash), however, do not give the names with which we are familiar in the OT (Aram Naharaim, Aram Zobah, etc), and have evidently to be sought in different positions, indicating that they represent an earlier stage of their migrations. With regard to their positions, it has been suggested that Uz lay in the neighborhood of the Hauran and Damascus; Hul near the Sea of Galilee; and that Mash stands for Mons Masius. This last, however, may have been the land of Mas, W. of Babylonia.

Only one son is attributed to Arpachshad, namely, Shelah (*shālah*, *shelah*, 10 24), unidentified as a nationality. This name should, how-

ever, indicate some part of Babylonia, esp. if his son, Eber, was the ancestor of the Hebrews, who were apparently migrants from Ur (*Mugheir*) (see ABRAHAM; UR OF THE CHALDEES).

Though Peleg, "in whose days the land was divided," may not have been an important link in the chain, the explanatory phrase needs notice. It may refer to the period when the fertilizing watercourses of Babylonia—the "rivers of Babylon" (Ps 137 1)—were first constructed (one of their names was *pelegh*), or to the time when Babylonia was divided into a number of small states, though this latter seems to be less likely. Alternative renderings for Shelah, Eber and Peleg are "sending forth" (Bohlen), "crossing" (the Euphrates), and "separation" (of the Joktanites) (Bohlen), respectively.

The Bab geographical fragment 80-6-17, 504 has a group explained as *Pulukku*, perhaps a modified form of Peleg, followed by (*Pulukku*) *ša ebirti*, "Pulukku of the crossing," the last word being from the same root as

Eber. This probably indicates a city on one side of the river (? Euphrates), at a fordable point, and a later foundation bearing the same name on the other side.

Reu, Serug, and Nahor, however, are regarded generally as place-names, and Terah as a personal name (the father of Abram, Nahor and Haran). From this point onward the text (11 27) becomes the history of the Israelitish nation, beginning with these patriarchs.

*Arguments for its early date.*—There is hardly any doubt that we have in this ethnographical section of Gen one of the most valuable records of its kind. Concerning the criticisms upon it which have been made, such things are unavoidable, and must be regarded as quite legitimate, in view of the importance of the subject. The interpolated sections concerning Nimrod and the Tower of Babel are such as would be expected in a record in which the compiler aimed at giving all the information which he could, and which he thought desirable for the complete understanding of his record. It may be regarded as possible that this information was given in view of the connection of Abraham with Babylonia. In his time there were probably larger cities than Babylon, and this would suggest that the building of the Bab capital may have been arrested. At the time of the captivity on the other hand, Babylon was the largest capital in the then known world, and the reference to its early abandonment would then have conveyed no lesson—seeing the extent of the city, the reader realized that it was only a short setback from which it had suffered, and its effects had long since ceased to be felt.

**10. Value of Table and Its Historical Notes**

*Limits of its information.*—For the early date of the Table also speaks the limited geographical knowledge displayed. Sargon of Agadé warred both on the E. and the W. of Babylonia, but he seems to have made no expeditions to the N., and certainly did not touch either Egypt or Ethiopia. This suggests not only that the information available was later than his time, but also that it was obtained from merchants, travelers, envoys and ambassadors. The scantiness of the information about the North of Europe and Asia, and the absence of any reference to the Middle or the Far East, imply that communications were easiest on the W., the limit of trade in that direction being apparently Spain. If it could be proved that the Phoenicians came as far westward as Britain for their tin, that might fix the latest date of the compilation of the Table, as it must have been written before it became known that their ships went so far; but in that case, the date of their earliest journeys thither would need to be fixed. Noteworthy is the absence of any reference to the Iranians (Aryan Persians) on the E. These, however, may have been included with the Medes (Madaï), or one of the unidentified names of the descendants of Japheth in Gen 10 2.3.

See SHERM; HAM; JAPHETH, and the other special articles in this Encyclopaedia; also, for a great mass of information and theories by many scholars and specialists, Dillmann, *Kurzgefasstes exegetisches Handbuch zum AT*, "Die Genesis," Leipzig, 1882; W. Max Müller, *Asien und Europa*, Leipzig, 1893; and F. Hommel, *Grundriss der Geographie und Geschichte des alten Orients*, Munich, 1904.

T. G. PINCHES

**TABLET**, tab'let: A rigid flat sheet (plate, pad or slab) used to receive writing. Stone, clay, wood and perhaps bronze, gold and lead tablets, at least, are mentioned in the Bible. In the Old Eng. sense of "locket" the word is incorrectly used in AV also

of what RV translates as "armlets," m "necklaces" (Ex 35 22; Nu 31 50) and "perfume boxes" (Isa 3 20).

The technical Heb word for tablet, לִיטָה, *lū'ah*, is generally tr<sup>d</sup> in both AV and RV as "table." This is used for stone, wood or metal plates or tablets with or without writing. In Isa (30 8) where RV translates "tablet," it is contrasted with the "roll" and probably means the wood or waxed tablet. In Hab (2 2, ARV "tablet," AV and ERV "table") it perhaps refers to a metal tablet to be erected on a wall, but more likely it refers to the wooden tablet. It is also used in Prov (3 3; 7 3, ARV "tablet," AV and ERV "table") and in Jer (17 1) figuratively of the writing upon the tablets of the heart, the word being rendered in LXX by the same word (*plax*) used by St. Paul (2 Cor 3 3, "tables" in AV and RV) in the same figure. In other cases (Ex 24 12, etc) it is used of the tablets of stone containing the Decalogue.

The word גְּלִיּוֹן, *gillayōn* (Isa 8 1), which is tr<sup>d</sup> in RV "tablet" and in AV "roll," is elsewhere (3 23) tr<sup>d</sup> "mirror," and is thought to mean a blank polished surface for writing, particularly because in later use it means the blank margin of a roll. But see ROLL.

The clay tablet is referred to in Ezk (4 1, EV "tile"), and its use there for a map of the city has been strikingly illustrated in modern excavation by a tablet map discovered at Nippur (Hilprecht, *Explorations*, 518). Jeremiah (32 14, RV "deeds," AV "evidences") may also refer to clay tablets, but not surely, since roll deeds were also kept in earthen jars. Job (19 24) is thought by some to refer to the writing on leaden tablets, such as were in very common use in antiquity and in the Middle Ages for the writing of charms and esp. curses, but more hold that inscriptions filled with lead are meant here. The plate of pure gold (Ex 28 36; Lev 8 9), engraved like the gravings of a signet, which was on Aaron's miter, may also be properly described as a tablet, recalling the silver treaty between the Hittites and Egyptians and the gold plate on which Queen Helena of Adiabene (*Yōmā* 37a; *Jew Enc*, VI, 334) had engraved a passage from the Pent (Nu 5 19-22). Bronze tablets (*δέλτος*, *deltos*) are several times referred to in 1 Macc (8 22; 14 18.27.48).

"Daleth" (*dāleth* or *deleth*), the Sem (Phoen) original from which the generic Gr word for tablet (*deltos*) is derived (Gardthausen, p. 124, n. 1), is perhaps not found strictly in this meaning in the OT. The word is used, however, of two kinds of written documents and in such a way as to suggest that one is the original of, and the other derived from, the "daleth"-tablet. In Dt 6 9 and 11 20 it is enjoined that the laws of Jeh shall be written upon the gates of the houses, and in each case the "daleths" or doors are meant, since the door-posts are also mentioned, and in 1 S 21 13, where David "scrabbles," it is expressly said to be upon the "doors" ("daleths") of the gate. This practice of writing upon house doors and city gates corresponds to the modern posting of notices on church doors and scoring of tallies on a door by the rural innkeeper; and the name seems to have passed from this great door tablet to the portable tablet. On the other hand Jeremiah (36 23) uses "daleths" (EV "leaves") for the columns of a roll, obviously transferring the term from the panel form of the folding tablets.

Πινακίς, *pinakis*, or πινακίδιον, *pinakidion*, is found in Ezk 9 2.11 in the version of Symmachus in place of the "writer's inkhorn," and *pinakidion*, in Lk 1 63, of the (wooden) tablet on which Zacharias wrote the name of John. *Puxion* is used several

times by LXX as the tr for *lū<sup>h</sup>*, and once (Cant 5 14) for ivory tablets. *Sanis* is used as the tr of "daleth" or *lū<sup>h</sup>* 2 or 3 t in LXX and still oftener in the other VSS. The commonest Gr term both in the NT (2 Cor 3 3; He 9 4) and in the Gr OT is *πλάξ*, *plāx*, oftenest used of the tables of stone. This, like *plátos*, which is also used for *lū<sup>h</sup>* in LXX, is not recognized in the modern textbooks (Thompson, Gardthausen, Birt).

LITERATURE.—Gardthausen, *Griechische Palaelog.*, Leipzig, I (1911), 123-32; cf pp. 24-45. See also literature under WRITING.

E. C. RICHARDSON

**TABOR**, *tā'bēr*, *tā'bôr* (תָּבוֹר, *tābhôr*; B, Θαχχειά, *Thachcheiá*, A, Θαβώρ, *Thabôr*): One of the towns in the territory of Zebulun, given to the Merarite Levites (1 Ch 6 77). The ¶ list in Josh 21 24 f contains no name like this. There is no indication of its position. Some have thought that it may correspond to Daberath in the territory of Issachar (ver 28), now represented by *Debáriyeh* on the western slope of Mt. Tabor; others that it may be the mountain itself; and yet others that it may be a city on the mountain, which probably was occupied from very early times. There is a Tabor mentioned as on the border of Issachar (Josh 19 22); but that is almost certainly the mountain. It has been suggested that Tabor in 1 Ch 6 17 may be a contraction of Chisloth-tabor (Josh 19 12), the modern *Iksāl*, 3 miles W. of the mountain. No certainty is possible. W. EWING

**TABOR, MOUNT** (תְּבוֹר, *tābhôr*, הַר תְּבוֹר, *har tābhôr*; ὄρος Θαβώρ, *óros Thabôr*, τὸ Ἰταβύριον, *tó Itabúrión*): This mountain seems to be named as on the border of Issachar (Josh 19 22). It is possibly identical with the mountain to which Zebulun and Issachar were to call the peoples (Dt 33 19). Standing on the boundary between the tribes, they would claim equal rights in the sanctuary on the top. The passage seems to indicate that it was a place of pilgrimage. The worshippers, bringing with them the "abundance of the sea" and the "treasures of the sand," would be a source of profit to the local authorities. The mountain can be no other than *Jebel et-Tūr*, an isolated and shapely height, rising at the northeast corner of the Plain of Esdraelon, about 5 miles W. of Nazareth. The mountain has retained its sacred character, and is still a place of pilgrimage, only the rites being changed. The present writer has mingled with great interest among the crowds that assemble there from all parts at the Feast of the Transfiguration.

It was on the summit and slopes of this mountain that Deborah and Barak gathered their forces; and hence they swept down to battle with Sisera in the great plain (Jgs 4 6.12.14). Here probably the brothers of Gideon were murdered by Zeba and Zalmunna (8 18). Moore ("Jgs," ICC, ad loc.) thinks the scene of the slaughter must have been much farther S. He does not see what the brothers of Gideon were doing so far N. of their home in Abiezer. There is, however, no reason for placing Ophrah so far to the S. as he does; and in any case the men were probably captured and taken to Tabor as prisoners. Jos (*Ant.*, VII, ii, 3) says it was in one of Solomon's administrative districts (cf 1 K 4 17). Such a prominent and commanding position must always have invited fortification. In the time of Antiochus the Great, 218 BC, we find a fortress here, which that king took by stratagem, Atabyrion by name (Polyb. v. 70, 6). It was recovered by the Jews, and was held by them under Jannæus, 105-70 BC (*Ant.*, XIII, xv, 4). The place fell to the Romans at the conquest under Pompey; and not far from the mountain Alexander,

son of Aristobulus II, suffered defeat at the hands of Gabinius, proconsul of Syria, 53 BC (*Ant.*, XIV, iv, 3; *BJ*, I, viii, 7). Jos, who commanded in Galilee at the outbreak of the Jewish war, recognized the importance of the position, and built a wall round the summit. After the disaster to Jewish arms at Jotapata, where Jos himself was taken prisoner, many fugitives took refuge here. Placidus the Rom general did not attempt an assault upon the fortress. Its defenders were by a feint drawn into the plain, where they were defeated, and the city surrendered.

A tradition which can be traced to the 4th cent. AD places the scene of the Transfiguration on this mountain. Allusion has been made above to the sacred character of the place. To this, and to the striking appearance of the mountain, the rise of the tradition may have been due. Passing centuries have seen a succession of churches and monasteries erected on the mountain. The scene of the Transfiguration was laid at the southeastern end of the summit, and here a church was built, probably by Tancred. Hard by was also shown the place where Melchizedek met Abraham returning from the pursuit of Chedorlaomer. The mountain shared to the full the vicissitudes of the country's stormy history. In 1113 AD the Arabs from Damascus plundered the monasteries and murdered the monks. An unsuccessful attack was made by Saladin in 1183, but 4 years later, after the rout of the Crusaders at Hattin, he devastated the place. Twenty-five years after that it was fortified by el-Melek el-Ádel, brother of Saladin, and the Crusaders failed in an attempt to take it in 1217. In 1218, however, the Saracens threw down the defences. Sultan Bihars in 1263 ordered the destruction of the Church of the Transfiguration, and for a time the mountain was deserted. The Feast of the Transfiguration, however, continued to be celebrated by the monks from Nazareth. During the last quarter of the 19th cent. much building was done by the Lat and Gr churches, who have now large and substantial monasteries and churches. They have also excavated the ruins of many of the old ecclesiastical buildings. The remains now to be seen present features of every period, from Jewish times to our own.

Mt. Tabor rises to a height of 1,843 ft. above the sea, and forms the most striking feature of the landscape. Seen from the S. it presents the shape of a hemisphere; from the W. that of a sugar loaf. Its rounded top and steep sides are covered with thick brushwood. It is about half a century since the oak forest disappeared; but solitary

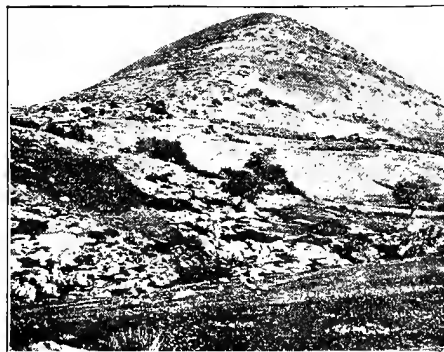

Mt. Tabor.

survivors here and there show what the trees must have been. A low neck connects the mountain with the uplands to the N. It is cut off from *Jebel ed-Duhy* on the S. by a fertile vale, which breaks down into *Wady el-B'reh*, and thence to the Jordan. A zigzag path on the N.W. leads to the top, whence most interesting and comprehensive views are obtained. Southward, over Little Hermon, with Endor and Naim on its side, and Shunem at its western base, we catch a glimpse of Mt. Gilboa. Away across the plain the eye runs along the hills on the northern boundary of Samaria, past Taanach and Megiddo to Carmel by the sea,

and the oak forest that runs northward from the gorge of the Kishon. A little to the N. of W., 5 miles of broken upland, we can see the higher houses of Nazareth gleaming white in the sun. Eastward lies the hollow of the Jordan, and beyond it the wall of Gilead and the steep cliffs E. of the Sea of Galilee, broken by glens and watercourses, and esp. by the great chasm of the *Yarmūk*. The mountains of Zebulun and Naphtali seem to culminate in the shining mass of Great Hermon, rising far in the northern sky. Standing here one realizes how aptly the two mountains may be associated in the Psalmist's thought, although Hermon be mighty and Tabor humble (Ps 89 12). Tabor is referred to by Jeremiah (46 18), and Hosea alludes to some ensnaring worship practised on the mountain (5 1).

The present writer spent some weeks on Mt. Tabor, and as the result of careful observation and consideration concluded that the scene of the Transfiguration cannot be laid here. The place would appear to have been occupied at that time; and the remoteness and quiet which Jesus evidently sought could hardly have been found here. See TRANSFIGURATION, MOUNT OF.

W. EWING

**TABOR, OAK (AV PLAIN) OF** (אֵלֶּן תְּבוֹר, *ēlōn tābhōr*; ἡ δρῦς Θαβώρ, *hē drūs Thabōr*): A place mentioned only in Samuel's directions to Saul after his anointing (1 S 10 3). It lay between the city where the two met and Gibeath whither Saul was returning. Ewald and Thenius thought it might be identical with the palm tree of Deborah, but there is nothing to support this conjecture. Others have thought we might read "oak of Deborah," as signifying the place where Rachel's nurse was buried (Gen 35 8). The truth is that nothing whatever is now known of the site.

W. EWING

**TABRET**, tab'ret, **TIMBREL**, tim'brel. See MUSIC, III, 3, (1).

**TABRIMMON**, tab-rim'on, tab'ri-mon (תְּבַרִּימֹן, *tabhrimmōn*, "Rimmon is good"; B, Ταβερεμά, *Taberemá*, A, Ταβερνημά, *Tabernraēmá*): The son of Hezion and father of BEN-HADAD (q.v.) (1 K 15 18, AV "Tabrimon").

**TACHES**, tach'iz. See CLASPS.

**TACHMONITE**, tak'mō-nīt. See TAHCHEMONITE.

**TACKLING**, tak'ling. See SHIPS AND BOATS, II, 2, (2).

**TADMOR**, tad'mor, tad'mōr (תְּדְמוֹר, *tadmōr*): A city built by Solomon in the wilderness (2 Ch 8 4), the Rom Palmyra. Tadmor is the native name and is found on inscriptions. It occurs also in the Kēre of 1 K 9 13, where the Kēthibh or consonants read "Tamar" (cf Ezk 47 19; 48 23). It is famous in Arabian as well as in Heb lit., and enters Rom history in connection with Zenobia and Longinus. The inscriptions, which belong for the most part to the latter period (266-73 AD), have been published by Dawkins and Wood and also by M. Waddington and the Duc de Luynes. Popular works on the subject are *An Account of Palmyra and Zenobia* by W. Wright, and *The Last Days and Fall of Palmyra* by W. Ware. See TAMAR.

THOMAS HUNTER WEIR

**TAHAN**, tā'han, **TAHANITES**, tā'han-its (תַּחַן, *tahān*, תַּחַנִּי, *tahānī*): The name of two Ephraimites who lived toward the end of the exodus of the Israelites (c 1415 BC).

(1) The head of one of the families of the tribe of Ephraim (Nu 26 35).

(2) The son of Telah and father of Ladan, also of the tribe of Ephraim (1 Ch 7 25 f).

**TAHAPANES**, ta-hap'a-nēz (תַּחַפְּנֵז, *tahpan-hēs*). See TAHAPANES.

**TAHASH**, tā'hash (תַּחַשׁ, *tahash*; Τόχος, *Tóchos*; AV *Tahash*): A son of Nahor by his concubine Reumah (Gen 22 24). The word תַּחַשׁ means a kind of leather or skin, and perhaps the animal yielding it, probably the "dungong" (cf Brown, Briggs, and Driver). *Tahash* has been identified by Winckler with Tihis (Egypt), located on the Orontes, N. of Kadesh.

**TAHATH**, tā'hath (תַּחַת, *tahath*, "below"): A wilderness station of the Israelites (Nu 33 26,27), between Makheloth and Terah. See WANDERINGS OF ISRAEL.

**TAHATH:**

(1) A Kohathite Levite (1 Ch 6 24).

(2) The name is mentioned twice among the sons of Ephraim (1 Ch 7 20); two families may be meant, or perhaps the name has been accidentally repeated.

**TAHCHEMONITE**, ta-kē'mō-nīt, tā'kē-mon-it (תַּחְכְּמוֹנִי, *tahkēmōnī*): Name of a family to which Jashobeam, the chief captain in David's army, belonged (2 S 23 8; 1 Ch 11 11). In 1 Ch it is "Hachmonite."

**TAHPANHES**, tā'pan-hēz, tā-pan'hēz (usually in the OT תַּחַפְּנֵז, *tahpanhēs*; LXX Ταφνάς, *Taphnás*; Coptic, *Taphnes*): The various spellings of the Heb text are fairly well indicated in AV by Tahapanes (Jer 2 16); Tahpanhes (Jer 43 7-9; 44 1; 46 14); Tehaphnehes (Ezk 30 18), while an Egypt queen (XXIst Dynasty) is named Tahpenes (1 K 11 19,20). T. was a city on the eastern frontier of Lower Egypt, represented today by *Tell Defenneh*, a desert mound lying some 20 miles S.W. from Pelusium (Bib. "Sin") and a little N. of the modern *Al-Kantarah* ("the bridge"), marking the old caravan route from Egypt to Pal, Mesopotamia and Assyria. Its Egypt name is unknown, but it was called *Δαφναί*, *Daphnaí*, by the Greeks, and by the modern Arabs *Defneh*. The site is now desolate, but it was a fertile district when watered by the Pelusiac branch of the Nile (cf Isa 19 6,7). T. was so powerful that Jeremiah can say that it, with Memphis, has "broken the crown" of Israel's head (2 16), and Ezekiel can speak of its "daughters" (colonies or suburban towns), and names it with Heliopolis and Bubastis when the "yokes [LXX "sceptres"] of Egypt" shall be broken by Jeh (30 18). In a later passage Jeremiah describes the flight of the Jews from their ruined capital to T. after the death of Gedaliah (43 1-7) and prophesies that Nebuchadnezzar shall invade Egypt and punish it, establishing his throne upon the brick pavement (AV "kiln") which is at the entry of Pharaoh's royal palace at T. (43 8-11). He calls T. as a witness to the desolation of the cities of Judah (44 1), but prophesies an equal destruction of T. and other Egypt cities (probably occupied by fugitive Jews) when Nebuchadnezzar shall smite them (46 14).

This invasion of Egypt by Nebuchadnezzar was for a long time strenuously denied (e.g. as late as 1839 by Kuenen, *Historisch-critisch Onderzoek*, 265-318); but since the discovery and publication (1878) of fragments of Nebuchadnezzar's annals in which he affirms his invasion

of Egypt in his 37th year (568-567 BC), most scholars have agreed that the predictions of Jeremiah (43 9-13; 44 30) uttered shortly after 586 BC and of Ezekiel (29 30) uttered in 570 BC were fulfilled, "at least in their general sense" (Driver, *Authority and Archaeology*, 116). Three cuneiform inscriptions of Nebuchadnezzar were found by Arabs probably on or near this site. The excavation of T. in 1886 by W. M. Flinders Petrie made it "highly probable that the large oblong platform of brickwork close to the palace fort built at this spot by Psammetichus I, c 664 BC, and now called *Kasr Bint el-Yehudi*, 'the castle of the Jew's daughter,' is identical with the quadrangle 'which is at the entry of Pharaoh's house in T.' in which Jeremiah was commanded to bury the stones as a token that Nebuchadnezzar would spread his pavilion over them when he led his army into Egypt" (ib. 117). Jos explicitly mentions that Nebuchadnezzar, when he captured T., carried off a Jewish contingent from that city (*Ant.* IX, vii). Dr. Petrie found that while a small fort had existed here since the Rameside era (cf Herod. ii.17), yet the town was practically founded by Psammetichus I, continued prosperous for a century or more, but dwindled to a small village in Ptolemaic times. Many sealings of wine jars stamped with the cartouches of Psammetichus I and Amosis were found *in situ*. T. being the nearest Egypt town to Pal, Jeremiah and the other Jewish refugees would naturally flee there (43 7). It is not at all unlikely that Nebuchadnezzar's invasion of Egypt was partly due to Egypt's favorable reception of these refugees.

The pottery found at T. "shows on the whole more evidence of Greeks than Egyptians in the place. . . . Esp. between 607-587 BC a constant intercourse with the Gr settlers must have been going on and a wider intercourse than even a Gr colony in Pal would have produced. . . . The whole circumstances were such as to give the best possible opportunity for the permeation of Gr words and Gr ideas among the upper classes of the Jewish exiles" (Petrie, *Nebeshah and Defenneh*, 1888, 50). This was, however, only one of many places where the Greeks and Hebrews met freely in this century (see e.g. Duruy, *Hist of Greece*, II, 126-80; Cobern, *Daniel*, 301-7). A large foreign traffic is shown at T. in which no doubt the Jews took part. Discoveries from the 6th cent. BC included some very finely painted pottery, "full of archaic spirit and beauty," many amulets and much rich jewelry and bronze and iron weapons, a piece of scale armor, thousands of arrow heads, and three seals of a Syrian type. One of the few inscriptions prays the blessing of Neit upon "all beautiful souls." There was also dug up a vast number of minute weights evidently used for weighing precious metals, showing that the manufacture of jewelry was carried on here on a large scale. One of the most pathetic and suggestive "finds" from this century, which witnessed the Bab captivity, consisted of certain curious figures of captives, carved in limestone, with their legs bent backward from their knees and their ankles and elbows bound together (Petrie, *op. cit.*, chs ix-xii).

CAMDEN M. COBERN

**TAHPENES**, tā'pe-nēz, tā-pē'nēz (תַּהֲפֵנִים, *tahp'nēs*; LXX Θεκεμ[ε]ίνα, *Thekem[e]ina*): Queen of Egypt, the sister of Hadad's wife and the foster-mother of his son Genubath (1 K 11 19 f). See PHARAOH.

**TAHREA**, tā'rē-a, ta-rē'a (תַּהֲרֵא, *tahrēa*): Son of Micah, a descendant of Gibeon (1 Ch 9 41; in 8 35 "Tarea").

**TAHTIM-HODSHI**, tā-tim-hod'shī. See KADESH ON ORONTES.

**TAIL**, tāl (אַיִל, *'alyāh*; זָנָב, *zānābh*; οὐρά, *ourá*): The broad tail of the Syrian sheep, wrongly rendered "rump" (q.v.) in AV, is mentioned as one of the portions of sacrifice which was burned on the altar as a sweet savor to God (Ex 29 22). The 2d Heb word is used of the tails of serpents (Ex 4 4), of foxes, which Samson tied together in his cruel sport, in order to destroy the cornfields of the Philis by means of attached firebrands (Jgs 15 4,

etc). The following seems to be an allusion to this incident: "Fear not, neither let thy heart be faint, because of these two tails of smoking firebrands, for the fierce anger of Rezin and Syria, and of the son of Remaliah" (Isa 7 4).

Figurative: "Tail"=inferiority, as opposed to "head"=superiority, leadership. "Jeh will make thee the head, and not the tail; and thou shalt be above only, and thou shalt not be beneath; if thou shalt hearken unto the commandments of Jeh" (Dt 28 13; cf also ver 44).

In the NT we find *oura* used of the apocalyptic animals, scorpions, horses, and the dragon (Rev 9 10,19; 12 4).

H. L. E. LUERING

**TAKE**, tāk: Most of the very numerous examples of this word are still in good use and only a few call for special attention. "To take" in the sense of "capture" is still common, but when a person or living animal is in point, modern Eng. usually adds "prisoner" or "captive." EV not infrequently has this addition (Gen 14 14, etc), but more commonly "take" is used without it (Josh 10 39; Job 5 13; Sir 23 21; Jn 7 30, etc). An occasional obscurity is thus caused, as in Gen 27 3, "take me venison" for "hunt venison for me." "To take advice" (2 Ch 25 17; AV Jgs 19 30, RV "counsel") is "to reflect," not "to consult others" (cf 1 K 12 28; but contrast 2 K 6 8, etc). "To take knowledge of" is "to learn thoroughly," "investigate" (1 S 23 23, etc), as is "to take notice of" (2 S 3 36). "To take an oath of" (Gen 50 25, etc) is "to exact an oath of." "To be taken with a disease" in AV Mt 4 24; Lk 4 38 is "to suffer with" (RV "be holden with"), but in 1 Macc 9 55; 2 Macc 9 21 (AV and RV), the context gives the force "be attacked by," as in modern Eng. Cf AV Lk 8 37 (RV "holden"); Mic 4 9 (RV "take hold of"). "Take" occurs in the sense "overtake" in AV Gen 19 19 (RV "overtake"); Sir 36 26. "Take away" has sometimes a more forcible significance than in modern Eng., as in AV Lev 6 2, "a thing taken away by violence" (RV "robbery"); Dnl 11 12, AV "He hath taken away the multitude," where the meaning is "swept away" (cf RVm "carried away"; RV "shall be lifted up" is inappropriate here). So in "lest he take thee away with his stroke" (AV Job 36 18), "take away" means simply "slay." (The text here is intensely obscure, and RV has followed a different interpretation.) So "to be taken away" may mean simply "to die," as in Ezk 33 6; Wisd 14 15; Sir 16 9; 19 3; Mk 2 20, although in 1 Cor 5 2 it means "to be expelled." "To take away judgment" or "right" (Job 27 2; 34 5; Acts 8 33) is "to refuse it," but in Zeph 3 15 EV means "the sentence against thee is canceled" (Heb text dubious). Neh 5 2 AV has "take up" for "get" (so RV), perhaps with the connotation "on credit." "Take up" is also used frequently for "utter solemnly" (Nu 23 7; Isa 14 4, etc), a use due to the Heb "lift up," "exalt" (נָשָׂא, *nāsā*). For "take up" in the sense of "lift" (physically), cf Isa 40 15; Acts 7 43; AV 21 15. "Take care" in Tob 5 20; 1 Cor 9 9 AV (RV "to care") means "be anxious about," "have in mind." And the very obscure "scurility in the matter of giving and taking" (Sir 41 19) is explained by the Heb to mean "refusing the gift for which thou art besought." The following phrases are archaic, but hardly need explanation: "Take indignation" (Neh 4 1); "take wrong" (1 Cor 6 7); "take up in the lips" (Ezk 36 3; AV Ps 16 4, "take . . . into my lips," RV "take . . . upon my lips"); and in AV "take to record" (Acts 20 26, RV "testify unto"); "take shame" (Mic 2 6 AV).

BURTON SCOTT EASTON

**TALE**, tāl (תֹּלַע, *tōkhen*, מִתְּכֹנֶת, *mithkōneth*, מִשְׁפָּר, *mišpār*; ἄρος, *lēros*): In AV of the OT (with one exception, Ps 90 9) "tale" (in the sing.) means number. "Tell" often has the same meaning, e.g. "I may tell [i.e. reckon] all my bones" (Ps 22 17). When Moses requested permission to go three days' journey into the wilderness to sacrifice to Jeh, Pharaoh replied by demanding the full "tale" of bricks from the Israelites although they were compelled to provide themselves with straw (Ex 5 8.18; see also 1 S 18 27; 1 Ch 9 28). In Ps 90 9, "as a tale that is told" is a doubtful rendering (see GAMES). The LXX and Vulg render "as a spider's web." The literal and perhaps accurate tr is "as a sigh" (Driver, in the Parallel Psalter, gives "as a murmur"). The word used in this ps means "to whisper," or "speak *sotto voce*," as a devout believer repeats to himself the words of a favorite hymn or passage (Ps 1 2).

The disciples considered the account given by the women in regard to the resurrection as "idle tales" (AV, RV "idle talk"), lit. "nonsensical talk" (Lk 24 11).

In talebearer the word has another meaning, viz. "slandorous talk or gossip." The word occurs 5 t in Prov (11 13; 18 8 AV; 20 19; 26 20.22 AV) and once in Lev (19 16). The word used in Lev and also in Prov 20 19 means a person who gads about from house to house hawking malicious gossip (cf 1 Tim 5 13). From the same root comes the Heb word for "merchant." In Ezk 22 9 for AV "men that carry tales" RV gives "slandorous men," as Doeg (1 S 22 9.22); Ziba (2 S 16 3; 19 27); and a certain maid-servant (2 S 17 17). See SLANDER.

T. LEWIS

**TALENT**, tal'ent (כִּכְרָה, *kikkār*; τάλαντον, *tálan-ton*): A weight composed of 60 manehs (EV "pounds") equal to about 120 pounds troy and 96 pounds avoirdupois, or 672,500 grains, of the Phoen standard. See WEIGHTS AND MEASURES. When used in the monetary sense the talent might be either of silver or gold, and the value varied according to the standard, but is probably to be taken on the Phoen, which would give about £410, or \$2,050, for the silver talent and £6,150, or \$30,750, for the gold. See MONEY.

Figurative: "Talent," like "pound," is used metaphorically in the NT for mental and spiritual attainments or gifts (Mt 25 15-28).

H. PORTER

**TALITHA CUMI**, ta-lé'tha kōō'mē (ταλιθά κουμι, *talithá koumī*): Derived from the Aram. (תַּלְיָתָא קַמִּי, *talý'thā k'umī*, "damsel, arise"), which in the NT MSS is transliterated variously (WH, Ταλειθα κουμι, *Taleithá koumī*, otherwise Ταλιθα κουμι, *Talithá koumī*). We have no data for determining how far Jesus employed the Aram. language, but Mark (5 41) notes its use in this tender incident, and there is strong probability that Aram. was used normally, if not exclusively, by Christ. There is, however, no ground for attributing any magical significance to the use of the Aram. words in connection with this miracle.

**TALMAI**, tal'mī, tal'mā-i (תַּלְמַי, *talmai*):

(1) A clan, possibly of Aramaean origin, generally reputed to be of gigantic height; resident in Hebron at the time of the Heb conquest and driven thence by Caleb (Nu 13 22; Josh 15 14; Jgs 1 10).

(2) A son of Ammihur (or Ammihud), king of Geshur, a small Aramaean kingdom, and a contemporary of David, to whom he gave his daughter Maacah in marriage. When Absalom fled from David after the assassination of Amnon he took refuge with Talmai at Geshur (2 S 3 3; 13 37; 1 Ch 3 2).

**TALMON**, tal'mon (טַלְמוֹן, *ṭalmōn*): One of the porters in connection with the temple-service (1 Ch 9 17; Ezr 2 42; Neh 7 45; 11 19; 12 25).

**TALMUD**, tal'mud (תַּלְמוּד, *ṭalmūdh*):

- I. PRELIMINARY REMARKS AND VERBAL EXPLANATIONS
- II. IMPORTANCE OF THE TALMUD
- III. THE TRADITIONAL LAW UNTIL THE COMPOSITION OF THE MISHNA
- IV. DIVISION AND CONTENTS OF THE MISHNA (AND THE TALMUD)
  1. *Zerā'im*, "Seeds"
  2. *Mō'ēd*, "Feasts"
  3. *Nashim*, "Women"
  4. *Nēzikin*, "Damages"
  5. *Kōdāshim*, "Sacred Things"
  6. *Tēharōth*, "Clean Things"
- V. THE PALESTINIAN TALMUD
- VI. THE BABYLONIAN TALMUD
- VII. THE NON-CANONICAL LITTLE TREATISES AND THE TOSEPHTA
  1. Treatises after the 4th *šēdher*
  2. Seven Little Treatises

LITERATURE

The present writer is, for brevity's sake, under necessity to refer to his *Einleitung in den Talmud*, 4th ed, Leipzig, 1908. It is quoted here as *Intro*.

There are very few books which are mentioned so often and yet are so little known as the Talmud. It is perhaps true that nobody can now be found, who, as did the Capuchin monk Henricus Seynensis, thinks that "Talmud" is the name of a rabbi. Yet a great deal of ignorance on this subject still prevails in many circles. Many are afraid to inform themselves, as this may be too difficult or too tedious; others (the anti-Semites) do not want correct information to be spread on this subject, because this would interfere seriously with their use of the Talm as a means for their agitation against the Jews.

**I. Preliminary Remarks and Verbal Explanations.**—(1) מִשְׁנָה, *Mishnāh*, "the oral doctrine and the study of it" (from *shānāh*, "to repeat," "to learn," "to teach"), esp. (a) the whole of the oral law which had come into existence up to the end of the 2d cent. AD; (b) the whole of the teaching of one of the rabbis living during the first two centuries AD (*tannā'*, pl. *tannā'im*); (c) a single tenet; (d) a collection of such tenets; (e) above all, the collection made by Rabbi Jehūdāh (or Judah) ha-Nāsī'. (2) מַתְּוֵה, *G'mārā'*, "the matter that is learned" (from *g'mar*, "to accomplish," "to learn"), denotes since the 9th cent. the collection of the discussions of the Amoraim, i.e. of the rabbis teaching from about 200 to 500 AD.

(3) תַּלְמוּד, *Talmūdh*, "the studying" or "the teaching," was in older times used for the discussions of the Amoraim; now it means the Mish with the discussions thereupon.

(4) הֲלָכָה, *Hālākāh* (from *hālakh*, "to go"): (a) the life as far as it is ruled by the Law; (b) a statutory precept.

(5) הִגְדָּה, *Higgādāh* (from *higgād*, "to tell"), the non-halakhic exegesis.

**II. Importance of the Talmud.**—Commonly the Talm is declared to be the Jewish code of Law. But this is not the case, even for the traditional or "orthodox" Jews. Really the Talm is the source whence the Jewish Law is to be derived. Whoever wants to show what the Jewish Law says about a certain case (point, question) has to compare at first the *Shulhān 'arākh* with its comm., then the other codices (Maimonides, Alphasi, etc) and the *Responsa*, and finally the Talmudic discussions; but he is not allowed to give a decisive sentence on the authority of the Talm alone (see *Intro*, 116, 117; David Hoffmann, *Der Schulchan-Aruch*, 2d ed, Berlin, 1894, 38, 39). On the other hand, no decision is valid if it is against the yield of the Tal-



metic discussion. The liberal (Reformed) Jews say that the Talm, though it is interesting and, as a Jewish work of antiquity, ever venerable, has in itself no authority for faith and life.

For both Christians and Jews the Talm is of value for the following reasons: (1) on account of the language, Heb being used in many parts of the Talm (esp. in Haggadic pieces), Palestinian Aram. in the Palestinian Talm, Eastern Aram. in the Bab Talm (cf "Literature," [7], below). The Talm also contains words of Bab and Pers origin; (2) for folklore, history, geography, natural and medical science, jurisprudence, archaeology and the understanding of the OT (see "Literature," [6], below, and *Intro*, 159-75). For Christians esp. the Talm contains very much which may help the understanding of the NT (see "Literature," [12], below).

**III. The Traditional Law until the Composition of the Mishna.**—The Law found in the Torah of Moses was the only written law which the Jews possessed after their return from the Bab exile. This law was neither complete nor sufficient for all times. On account of the ever-changing conditions of life new ordinances became necessary. Who made these we do not know. An authority to do this must have existed; but the claim made by many that after the days of Ezra there existed a college of 120 men called the "Great Synagogue" cannot be proved. Entirely untenable also is the claim of the traditionally orthodox Jews, that ever since the days of Moses there had been in existence, side by side with the written Law, also an oral Law, with all necessary explanations and supplements to the written Law.

What was added to the Pentateuchal Torah was for a long time handed down orally, as can be plainly seen from Jos and Philo. The increase of such material made it necessary to arrange it. An arrangement according to subject-matter can be traced back to the 1st cent. AD; very old, perhaps even older, is also the formal adjustment of this material to the Pentateuchal Law, the form of Exegesis (Midr). Cf *Intro*, 19-21.

A comprehensive collection of traditional laws was made by Rabbi Akiba c 110-35 AD, if not by an earlier scholar. His work formed the basis of that of Rabbi Me'ir, and this again was the basis of the ed of the Mish by Rabbi Jehudah ha-Nasi'. In this Mish, the Mish *par excellence*, the anonymous portions generally, although not always, reproduce the views of Rabbi Me'ir. See TIBERIAS.

The predecessors of Rabbi (as R. Jehudah ha-Nasi', the "prince" or the "saint," is usually called), as far as we know, did not put into written form their collections; indeed it has been denied by many, esp. by German and French rabbis of the Middle Ages, that Rabbi put into written form the Mish which he edited. Probably the fact of the matter is that the traditional Law was not allowed to be used in written form for the purposes of instruction and in decisions on matters of the Law, but that written collections of a private character, collections of notes, to use a modern term, existed already at an early period (see *Intro*, 10 ff).

**IV. Division and Contents of the Mishna (and the Talmud).**—The Mish (as also the Talm) is divided into six "orders" (*ṣedharim*) or chief parts, the names of which indicate their chief contents, viz. *Zerā'im*, Agriculture; *Mō'edah*, Feasts; *Nāshim*, Women; *Nezikin*, Civil and Criminal Law; *Kōdhashim*, Sacrifices; *T'harōth*, Unclean Things and Their Purification.

The "orders" are divided into tracts (*massekheth*, pl. *masskhtōth*), now 63, and these again into chapters (*perak*, pl. *perakim*), and these again into paragraphs (*mishnayōth*). It is customary to cite the Mish accord-

ing to tract, chapter and paragraph, e.g. *Sanh.* (*Sanhedrin*) x.1. The Bab Talm is cited according to tract and page, e.g. (*Bab Shabbāth* 30b; in citing the Palestinian Talm the number of the chapter is also usually given, e.g. (*Pal Shabbāth* vi.8d (in most of the edd of the Palestinian Talm each page has two columns, the sheet accordingly has four).

(1) *Bērākōth*, "Benedictions": "Hear, O Israel" (Dt 6 4, *shema'*); the 18 benedictions, grace at meals, and other prayers.

1. *Zerā'im*, "Seeds" (2) *Pē'ah*, "Corner" of the field (Lev 19 9 f; Dt 24 19 ff).

(3) *Demā'ī*, "Doubtful" fruits (corn, etc) of which it is uncertain whether the duty for the priests and, in the fixed years, the 2d tithe have been paid.

(4) *Kil'ayim*, "Heterogeneous," two kinds, forbidden mixtures (Lev 19 19; Dt 22 9 ff).

(5) *Shebh'it*, "Seventh Year," Sabbatical year (Ex 23 11; Lev 25 1 ff); *Shemittāh* (Dt 15 1 ff).

(6) *Terūmōth*, "Heave Offerings" for the priests (Nu 18 8 ff; Dt 18 4).

(7) *Ma'āsērōth* or *Ma'āsēr rī'shōn*, "First Tithe" (Nu 18 21 ff).

(8) *Ma'āsēr shēni*, "Second Tithe" (Dt 14 22 ff).

(9) *Hallah*, (offering of a part of the) "Dough" (Nu 15 18 ff).

(10) *Orlāh*, "Foreskin" of fruit trees during the first three years (Lev 19 23).

(11) *Bikkūrim*, "First-Fruits" (Dt 26 1 ff; Ex 23 19).

(1) *Shabbāth* (Ex 20 10; 23 12; Dt 5 14).

(2) *Erabbim*, "Mixtures," i.e. ideal combination of localities with the purpose of facilitating the observance of the Sabbatical laws.

2. *Mō'edah*, "Feasts" (3) *Pesākim*, "Passover" (Ex 12; Lev 23 5 ff; Nu 28 16 ff; Dt 16 1); ch 9, the Second Passover (Nu 9 10 ff).

(4) *Shekalim*, "Shekels" for the Temple (cf Neh 10 33; Ex 30 12 ff).

(5) *Yamā*, "The Day" of Atonement (Lev 16).

(6) *Sukkah*, "Booth," Feast of Tabernacles (Lev 23 34 ff; Nu 29 12 ff; Dt 16 13 ff).

(7) *Bē'ah*, "Egg" (first word of the treatise) or *Yōm tōbh*, "Feast," on the difference between the Sabbath and festivals (cf Ex 12 10).

(8) *U'vsh ha-shanāh*, "New Year," first day of the month Tishri (Lev 23 24 f; Nu 29 1 ff).

(9) *Ta'anith*, "Fasting."

(10) *Meghillāh*, "The Roll" of Esther, Purim (Est 9 28).

(11) *Mō'edah katan*, "Minor Feast," or *Mashkin*, "They irrigate" (first word of the treatise), the days between the first day and the last day of the feast of Passover, and likewise of Tabernacles.

(12) *Haghighah*, "Feast Offering," statutes relating to the three feasts of pilgrimage (Passover, Weeks, Tabernacles); cf Dt 16 16 f.

(1) *Yebhamōth*, "Sisters-in-Law" (perhaps better, *Yebhamōth*, Levirate marriage; Dt 25 5 ff; cf Ruth 4 5; Mt 22 24).

(2) *Kethubōth*, "Marriage Deeds."

(3) *Nedharim*, "Vows," and their annul-

ment (Nu 30).

(4) *Nazir*, "Nazirite" (Nu 6).

(5) *Gittin*, "Letters of Divorce" (Dt

24 1; cf Mt 5 31).

(6) *Sotah*, "The Suspected Woman" (Nu 5 11 ff).

(7) *Kiddūshin*, "Betrothals."

(1) (2) and (3) *Bābhā kammā*, *Bābhā me'ē'ā*, *Bābhā bathrā*, "The First Gate," "The Second Gate," "The Last Gate," were in ancient times only one treatise called *Nezikin*: (a) Damages and injuries and the responsibility; (b) and

"Damages" (c) right of possession.

(4) and (5) *Sanhedrin*, "Court of Justice," and *Makkōth*, "Stripes," (Dt 25 1 ff; cf 1 Cor 11 24). In ancient times only one treatise; criminal law and criminal proceedings.

(6) *Shebh'it*, "Oaths" (Lev 5 1 ff).

(7) *Eduyōth*, "Attestations" of later teachers as to the opinions of former authorities.

(8) *Abhōdhah zārāh*, "Idolatry," commerce and intercourse with idolaters.

(9) *Abhōth*, (sayings of the) "Fathers"; sayings of the *Tannā'im*.

(10) *Hōrāyōth*, (erroneous) "Decisions," and the sin offering to be brought in such a case (Lev 4 13 ff).

(1) *Zebhā'im*, "Sacrifices" (Lev 1 ff).

(2) *Menāhōth*, "Meal Offerings" (Lev 2 5.11 ff; 6 7 f; Nu 5 15 ff, etc).

5. *Kōdhāshim*, "Sacred Things" (3) *Hullin*, "Common Things," things non-sacred; slaughtering of animals and birds for ordinary use.

(4) *Bekhorōth*, "The Firstborn" (Ex 13 2.12 f; Lev 27 26 f.32; Nu 8 6 ff, etc).

(5) *Arākbin*, "Estimates," "Valuations" of persons and things dedicated to God (Lev 27 2 ff).

(6) *Temurāh*, "Substitution" of a common (non-sacred) thing for a sacred one (cf Lev 27 10.33).

(7) *Kerūthōh*, "Excisions," the punishment of being cut off from Israel (Gen 17 14; Ex 12 15, etc.).

(8) *M'ūlāh*, "Unfaithfulness," as to sacred things, embezzlement (Nu 5 6 ff; Lev 5 15 f).

(9) *Tamidh*, "The Daily Morning and Evening Sacrifice" (Ex 29 38 ff; Nu 38 3 f).

(10) *Middōth*, "Measurements" of the Temple.

(11) *Kinnim*, "Nests," the offering of two turtle-doves or two young pigeons (Lev 1 14 ff; 5 1 ff; 12 8). This title is used euphemistically for "unclean things":

(1) *Kēlīm*, "Vessels" (Lev 6 20 ff; 11 32 ff; Nu 19 14 ff; 31 20 ff).

(2) *ʿOholōth*, "Tents," the impurity originating with a corpse or a part of it (cf Nu 19 14).

(3) *N'oghā'im*, "Leprosy" (Lev 13, 14).

(4) *Pārāh*, "Red Heifer"; its ashes used for the purpose of purification (Nu 19 2 ff). See HEIFER, RED.

(5) *T'ehārōth*, "Clean Things," euphemistically for defilements.

(6) *Mikwā'ōth*, "Diving-Baths" (Lev 15 12; Nu 31 33; Lev 14 8; 15 5 ff; cf Mk 7 4).

(7) *Niddāh*, "The Menstruous" (Lev 15 19 ff; 12).

(8) *Makhsirīn*, "Preparers," or *Mashkīn*, "Fluids" (first word of the treatise). Seven liquids (wine, honey, oil, milk, dew, blood, water) which tend to cause corn, etc. to become defiled (cf Lev 11 34.37 f).

(9) *Zābhīm*, "Persons Having an Issue," flux (Lev 15).

(10) *T'ebhāl yōm*, "A Person Who Has Taken the Ritual Bath during the Day," and is unclean until sunset (Lev 15 5; 22 6 f).

(11) *Yōdhayim*, "Hands," the ritual impurity of hands and their purification (cf Mt 15 2.20; Mk 7 22 ff).

(12) *Ukēin*, "Stalks," the conveyance of ritual impurity by means of the stalks and hulls of plants.

**V. The Palestinian Talmud.**—Another name, *Talmūd Y'erushalmī* ("Jerus Talm"), is also old, but not accurate. The Palestinian Talm gives the discussions of the Palestinian Amoraim, teaching from the 3d cent. AD until the beginning of the 5th, esp. in the schools or academies of Tiberias, Caesarea and Sepphoris. The edd and the Leyden MS (in the other MSS there are but few treatises) contain only the four *ṣ'dhārīm* i-iv and a part of *Niddāh*. We do not know whether the other treatises had at any time a Palestinian Gemara. "The Mish on which the Palestinian Talm rests" is said to be found in the MS Add. 470.1 of the University Library, Cambridge, England (ed W. H. Lowe, 1883). The treatises *'Eduyōth* and *'Abhōth* have no Gemara in the Palestinian Talm or in the Bab.

Some of the most famous Palestinian Amoraim may be mentioned here (cf *Intro*, 99 ff): 1st generation: Hānīnā bar Hāmā, Jannai, Jonathan, Osha'ya, the Haggadist Joshua ben Levi; 2d generation: Johanan bar Nappāhā, Simeon ben Lakish; 3d generation: Samuel bar Nahman, Levi, Eliezer ben Pedāth, Abhahu, Ze'ira (i); 4th generation: Jeremiah, Ahā, Abin (i), Jūdah, Hūnā; 5th generation: Jonah, Phinehas, Berechiah, Jose bar Ahin, Māni (ii), Tanhūmā'.

**VI. The Babylonian Talmud.**—The Bab Talm is later and more voluminous than the Palestinian Talm, and is a higher authority for the Jews. In the first *ṣ'dher* only *B'rākhōth* has a Gemara; *She'kālīm* in the 2d *ṣ'dher* has in the MSS and in the edd the Palestinian Gemara; *Middōth* and *Kinnim* in the 5th *ṣ'dher* have no Bab Gemara. The greatest Jewish academies in Babylonia were in Nehardea, Šura, Pumbeditha and Maḥza.

Among the greatest Bab Amoraim are the following (cf *Intro*, 99 ff): 1st generation: Abba Arikhā or, shortly, Rab in Šura (d. 247 AD). Mar Samuel in Nehardea (d. 254 AD). 2d generation: Rab Hūnā, Rab Judah (bar Ezekiel). 3d generation: Rab Hišda, Rab Shēsheth, Rab Naḥman (bar Jacob), Rabbāh (רַבָּה) bar Ḥana, the story-teller, Rabbāh bar Nahmāni, Rab Joseph (d. 323 AD). 4th generation: Abāyē, Rābā (רַבָּא) (bar Joseph). 5th generation: Rab Pāpā. 6th generation: Amēmar, Rab Ashi.

**VII. The Non-canonical Little Treatises and the Tōsephā'.**—In the edd of the Bab Talm after

the 4th *ṣ'dher* we find some treatises which, as they are not without some interest, we shall not pass over in silence, though they do

1. Treatises not belong to the Talm itself (cf *Intro*, after the 69 ff).

**4th ṣ'dher** (1) *'Abhōth d'Rabbī Nāthān*, an expansion of the treatise *'Abhōth*, ed S. Schechter, Vienna, 1887.

(2) *Šōpherīm*, ed Joel Müller, Leipzig, 1878.

(3) *'Ebbel Rabbāthī*, "Mourning," or, euphemistically, *Semāhōth*, "Joys."

(4) *Kallāh*, "Bride."

(5) *Derekh 'erec*, "Way of the World," i.e. Deportment; *Rabbā* and *Zūṭā*, "Large" and "Small." *Septem Libri Talmudici parvi Hierolymitani*, ed R. Kirchheim, Frankfurt a. Main, 1851; *Šēpher Tōrah*, *M'ezūāh*, *T'ephillīn*, *Čičūth*,

2. Seven *'Abhādīm*, *Kūthīm* (Samaritans), Little *Gērīm* (Proselytes).

**Treatises** The *Tōsephā'*, a work parallel to Rabbi's Mish, is said to represent the views of R. Nehemiah, disciple of R. Aqiba, ed M. S. Zuckerman, Posewalk, 1880. Zuckerman tries to show that the *Tōsephā'* contains the remains of the old Palestinian Mish, and that the work commonly called Mish is the product of a new revision in Babylonia (cf his *Tosephta, Mischna und Boraiha in ihrem Verhältniss zu einander*, 2 vols, Frankfurt a. Main, 1908, 1909).

**LITERATURE.**—(1) *Intros*: Hermann L. Strack, *Einführung in d. Talm.*, 4th ed, Leipzig, 1908, in which other books on this subject are mentioned, pp. 139-44.

(2) *Manuscripts* (*Intro*, 72-76): There are MSS of the whole Mish in Parma, in Budapest, and in Cambridge, England (the latter is published by W. H. Lowe, 1883). The only codex of the Palestinian Talm is in Leyden; Louis Ginsberg, *Yerushalmi Fragments from the Genizah*, vol I, text with various readings from the *editio princeps*, New York, 1909 (372 pp., 4to). The only codex of the Bab Talm was published whole in 1912 by the present writer: *Talmud Bab codicis Heb Monacensis 95 phototypice depictum*, Leyden (1140 plates, royal folio). On the MSS in the Vatican see S. Ochser, *ZDMG*, 1909, 365-93.626, 822 f.

(3) *Editions* (*Intro*, 76-81): (a) Mish, *editio princeps*, Naples, 1492, folio, with the comm. of Moses Maimonides; *Riva di Trento*, 1559, folio, contains also the comm. of Obadiāh di Bertinoro. The new ed printed in Wilna contains a great number of comms. (b) Palestinian Talm, *editio princeps*, Venice, 1523 ff, folio; Cracow, 1609, folio. Of a new ed begun by A. M. Luncz, Jerus, 1908 ff, two books, *B'rākhōth* and *P'ēah*, are already published. Another new critical ed, with Ger. tr and notes, was begun in 1912 by G. Beer and O. Holtzmann (*Die Mischna*, Giessen). Cf also B. Ratner, *Ahabath Čiṭjon Wirushalayim, Varianten und Ergänzungen des Jerus Talmuds*, Wilna, 1901 ff. (c) Bab Talm, *editio princeps*, Venice, 1520-23. The ed, Bāle, 1578-81, is badly disfigured by the censorship of Marcus Marinus, Amsterdam, 1644-48, Berlin 1862-66. Cf R. Rabinowicz, *Variae Lectiones in Mish et in Talm Babylonicum*, Munich, 1868-86, Przemysl, 1897 (the *ṣ'dhārīm* 3, 6 and 5 in part are missing).

(4) *Translations*: E. Bischoff, *Krit. Geschichte d. Talmudübersetzungen*, Frankfurt a. Main, 1899. (a) Mish, Lat: Guil. Surenhousius, Amsterdam, 1698-1703 (contains also a tr of Maimonides and Obadiāh di Bertinoro); Ger.: J. J. Rabe, Onolzbach, 1760 ff; A. Samtner, D. Hoffmann and others, Berlin, 1887 ff (not yet complete); Eng.: De Sola and Raphall, *18 Treatises from the Mish*, London, 1843; Jos. Barclay, *The Talm.*, a Tr of 18 Treatises, London, 1878 (but 7 treatises also in De Sola and Raphall; Fiebig, *Ausgewählte Mischnatractate*, Tübingen, 1905 ff (annotated Ger. tr)). (b) Palestinian Talm, Lat: 20 treatises in B. Ugolini, *Thesaurus antiquitatum sacrarum*, vols XVII-XXX, Venice, 1755 ff. French: M. Schwab, Paris, 1878-89 (in 1890 appeared a 2d ed of vol I). (c) Bab Talm, Ger.: L. Goldschmidt, Berlin (Leipzig), 1897 ff; gives also the text of the 1st Venetian ed and some variant readings (*ṣ'dhārīm* 1, 2, and 4 are complete); A. Wünsche, *Der Bab Talm in seinen haggadischen Bestandteilen übersetzt*, Leipzig, 1886-89. Eng.: M. L. Rodkinson, *New Ed of the Bab Talm*. . . . Trd into Eng., New York, 1896 ff (is rather an abridgment [unreliable]).

(5) *Comms.* (*Intro*, 146-51): (a) Mish: Moses Maimonides (1135-1204), Obadiāh di Bertinoro (d. 1510), Yōm-Tōbbh Lipmann Heller (1579-1654), Israel Lipšütz. (b) Bab Talm: Rashi or Solomon Yīčāki (d. 1105); *The Tōsaphōth* (see L. Zunz, *Zur Geschichte und Literatur*, Berlin, 1845, 29-60); Menahem ben Solomon

or Mō'irī (1249-1306); Solomon Luria (d. 1573), commonly called *Maharshal*; Bezaleel Ashkenazi (16th cent.), author of the *Shifṭāh M'kubbeceth*; Samuel Edels (1559-1631) or *Maharshe'*; Moir Lublin (d. 1616); Elijah Wilna (d. 1797); Akiba Eger (d. 1837).

(6) *Single treatises* (cf *Intro*, 151-55): (a) Mish: The present writer is publishing: *Ausgewählte Mishnatraktate, nach Handschriften und alten Drucken (Text vokalisiert, Vokabular)*, übersetzt und mit Berücksichtigung des Neuen Testaments erläutert, Leipzig (J. C. Hinrichs); *Yomā*, 3d ed, 1912, 'Abhōdhāh Zārāh, 2d ed, 1909, *Pirṭe 'Abhōth*, 4th ed, 1914, *Shabbāth*, 2d ed, 1914, *Sanhedhrin*, *Makkōth*, 1910, *P'sāhim*, 1911, *B'rākhōth*, 1914. This series is to be continued (H. Laible, e.g., is writing *N'edahrim*); Ch. Taylor, *Sayings of the Jewish Fathers*, in Heb and Eng., 2d ed, Cambridge, 1897; W. A. L. Elmslie, *The Mish on Idolatry*, with Tr. Cambridge, 1911. (b) Gemara, *B'rākhōth*, Ger.: E. M. Pinner, Berlin, 1842, fol; *P'ēh* (Palestinian Talm.), Ger.: J. J. Rahe, Ansbach, 1781; *Sukkah*, Lat.: F. B. Dachs, Utrecht, 1726, 4to; *Rō'sh ha-shānāh*, Ger.: M. Rawicz, Frankfurt a. Main, 1836; *Ta'anūth*, Ger.: Straschun, Halle, 1883; *Hāghighāh*, Eng.: A. W. Streane, Cambridge, 1891; *K'ihūbhōth*, Ger.: M. Rawicz, 1891; *Sōtah*, Lat.: J. Chr. Wagenseil, Altdorf, 1674-78; *Bābhā M'ēṣ'ā*, Ger.: A. Sammter, Berlin, 1876, fol; *Sanhedhrin*, Lat.: Ugolini, *Thesaurus*, vol XXV, Ger.: M. Rawicz, 1892; 'Abhōdhāh Zārāh, Ger.: F. Chr. Ewald, Nürnberg, 1856; *Z'bhāhin* and *M'nāhōth*, Lat.: Ugolini, *Thesaurus*, vol XIX; *Hullīn*, Ger.: M. Rawicz, Offenburg, 1908; *Tāmīdh*, Lat.: Ugolini, *Thesaurus*, vol XIX.

(7) *Helps for the Grammatical Understanding* (*Intro*, 155-58): (a) Mish: M. H. Segal, "Mishnaic Hebrew," *JQR*, 1908, 647-737; K. Albrecht, *Grammatik des Neuhebräischen (Sprache der Mishna)*, Munich, 1913; (b) Talmud: J. Levy, *Neuhebr. und chald. Wörterbuch*, Leipzig, 1876-89; M. Jastrow, *Dictionary of the Talmud Bab and Yerushalmi*, New York, 1886-1903; W. Bacher, *Die Terminologie der jüd. Traditionsliteratur*, Leipzig, 1905; G. Dalman, *Grammatik des jüdisch-paläst. Aramäisch*, 2d ed, Leipzig, 1905; C. Levias, *Grammar of the Aramaic Idiom Contained in the Bab Talmud*, Cincinnati, 1900; Max L. Margolis, *Grammar of the Aram. Language of the Bab Talmud with a Chrestomathy*, Munich, 1909.

(8) *The Haggadah* (*Intro*, 159-62): The Haggadic elements of the Palestinian Talm are collected by Samuel Jaffe in *Y'phēh Mar'eh*, Constantinople, 1587, etc, those of the Bab by Jacob ibn Ḥabib in 'En Ya'akōbh, Saloniki, about 1516, etc; W. Bacher, *Die Agada der Tannaiten*, 2 vols, Strassburg, 1884, 1890 (1st vol, 2d ed, 1903); *Die A. der babylon. Amoräer*, 1878; *Die A. der palästinensischen Amoräer*, 1892-99, 3 vols; P. T. Hershon, *A Talmudic Miscellany or 1001 Extracts*, London, 1880; *Treasures of the Talm.*, London, 1882.

(9) *Theology* (*Intro*, 162-65): F. Weber, *Jüdische Theologie*, 2d ed, Leipzig, 1897; J. Klausner, *Die messianischen Vorstellungen des jüd. Volkes im Zeitalter der Tannaiten*, Berlin, 1904; K. T. Herford, *Christianity in Talmud and Midrash*, London, 1903; H. L. Strack, *Jesus, die Häretiker und die Christen nach den ältesten jüd. Angaben* (texts, tr, comm.), Leipzig, 1910; L. Blau, *Das altjüdische Zauberwesen*, Budapest, 1898; M. Lazarus, *Die Ethik des Judentums*, 2 vols, Frankfurt a. Main, 1898, 1911.

(10) *The Talm and the OT* (*Intro*, 167 f): G. Aicher, *Das AT in der Mischna*, Freiburg i. Baden, 1906; V. Aptowitzer, *Das Schriftwort in der rabbin. Literatur*, 4 parts, Wien, 1906-11 (to be continued; various readings in the quotations); P. T. Hershon, *Gen. with a Talmudical Comm.*, London, 1883.

(11) *The Talm and the NT* (*Intro*, 165-67): Joh. Lightfoot, *Horae hebraicae et talmudicae*, ed Leusden, 2 vols, fol T, Franeker, 1699; Chr. Schöttgen, *Horae hebraicae et talmudicae in universum Novum Test.*, 2 vols, 4to, Dresden, 1733; Franz Delitzsch, "Horae hebraicae et talmudicae," in *Zeitschrift für die gesammte luther. Theologie u. Kirche*, 1876-78; Aug. Wünsche, *Neue Beiträge zur Erläuterung der Evangelien aus Talm und Midr.*, Goettingen, 1878; Th. Robinson, *The Evangelists and the Mish.*, London, 1859; W. H. Bennett, *The Mish as Illustrating the Gospels*, Cambridge, 1884; Erich Bischoff, *Jesus und die Rabbinen, Jesu Bergpredigt und "Himmelreich" in ihrer Unabhängigkeit vom Rabbinismus*, Leipzig, 1905.

(12) *Jurisprudence* (*Intro*, 169-71): J. L. Saalschütz, *Das Mosaische Recht*, 2d ed, Berlin, 1853; Jos. Kohler, "Darstellung des talmudischen Rechts," in *Zeitschrift für vergleichende Rechtswissenschaft*, 1908, 161-264; Z. Frankel, *Der gerichtliche Beweis nach mosaisch-talmud. Rechte*, Berlin, 1846; P. B. Benny, *The Criminal Code of the Jews*, London, 1880; S. Mendelsohn, *The Criminal Jurisprudence of the Ancient Hebrews*, Baltimore, 1891; H. B. Fassel, *Das mosaisch-rabbinische Civilrecht*, Gross-Kanischa, 2 vols, 1852-54; *Das mos.-rabb. Gerichtsverfahren in civilrechtl. Sachen*, 1859; M. Mielziner, *The Jewish Law of Marriage and Divorce*, Cincinnati, 1884; D. W. Amram, *The Jewish Law of Divorce*, Philadelphia, 1896; M. Rapaport, *Der Talmud und sein Recht*, Berlin, 1912.

(13) *History* (*Intro*, 171 f): J. Derenbourg, *Histoire de la Palestine depuis Cyrus jusqu'à Adrien*, Paris, 1867;

L. Herzfeld, *Handelsgeschichte der Juden des Altertums*, 2d ed, Braunschweig, 1894; A. Büchler, *The Political and the Social Leaders of the Jewish Community of Sephoris*, London, 1909; S. Funk, *Die Juden in Babylonien 200-600*, 2 vols, Berlin, 1902, 1908.

(14) *Medical Science* (*Intro*, 173): Jul. Preuss, *Biblich-talmudische Medizin*, Berlin, 1911 (735 pp.); L. Kotelmann, *Die Ophthalmologie bei den alten Hebräern*, Hamburg, 1910 (436 pp.).

(15) *Archaeology*: Sam. Krauss, *Talmudische Archäologie*, 3 vols, Leipzig, 1910-12.

HERMANN L. STRACK

**TALSAS**, tal'sas (A, Σαλόας, *Salóas*, B, Ζάλας, *Zálhas*; RV "Saloas"): In 1 Esd 9 22 AV = "Elasha" of Ezr 10 22.

**TAMAH**, tā'ma. See **TEMAH**.

**TAMAR**, tā'mar (תָּמָר, *tāmār*, "palm"; B, Θημάρ, *Thēmár*, A, Θαμάρ, *Thamár* [so B in Gen]):

(1) The wife of Er, the eldest son of Judah (Gen 38 6 ff). On her husband's death under the displeasure of Jeh, his brother Onan ought to have performed the husband's part, but he evaded his duty in this respect, and likewise perished. Shelah, the next brother, was promised to her, but not given. This led Tamar to the extraordinary course narrated in Gen 38 13 ff, on which see **JUDAH**. By her father-in-law she became the mother of Perez and Zerah (AV "Pharez and Zarah"). Judah, who at first condemned her to be burned (ver 24), was compelled to vindicate her (vs 25, 26). Through Perez she became an ancestress of Jesus (Θαμάρ, *Thamár*, Mt 1 3).

(2) A daughter of David and sister of Absalom (2 S 13 1 ff). Her beauty inflamed her half-brother Amnon with passion, and by stratagem he forcibly violated her. This brought upon Amnon the terrible revenge of Absalom. See **ABSALOM**; **AMNON**.

(3) A daughter of Absalom (2 S 14 27). See **MAACAII**. JAMES ORR

**TAMAR** (תָּמָר, *tāmār*, "palm tree"; Θαμάρ, *Thamár*):

(1) This name occurs in Ezekiel's ideal delimitation of the territory to be occupied by Israel (47 19; 48 28). The Dead Sea is the eastern border; and the southern boundary runs from Tamar as far as the waters of Meriboth-kadesh to the Brook of Egypt and the Great Sea. The place therefore lay somewhere to the S.W. of the Dead Sea. "Hazon-tamar (the same is En-gedi)" (2 Ch 20 2) is of course out of the question, being much too far to the N. *Onom* mentions Asasonthamar, with which *Thamara* was identified. This place was a village with fortress and Rom garrison, a day's journey from Mampsis on the way from Hebron to Elath. It is the *Thamara* mentioned by Ptolemy (v.16, 8), as a military station on the road from Hebron to Petra. It is named also in the Peutinger Tables. Neither Mampsis nor *Thamara* has been identified.

(2) Among the towns "built" or fortified by Solomon, named in 1 K 9 18, is Tamar (RV following K<sup>thibh</sup>), or Tadmor (AV following K<sup>rē</sup>; cf 2 Ch 8 4). Gezer, Beth-horon and Baalath, named along with it, are all in Southern Pal, while Tamar is described as in the wilderness in the land, pointing to the Negeb or to the Wilderness of Judah. It was probably intended to protect the road for trade from Ezion-geber to Jerus. We may with some confidence identify it with (1) above. It is interesting to note that the Chronicler (2 Ch 8 4) takes it out of connection with the other cities (ver 5), and brings its building into relation with Solomon's conquest of Hamath-zobah. Clearly in his mind it denoted the great and beautiful city of Palmyra, which has so long been known as "Tadmor in the Wilderness." W. EWING

**TAMARISK**, tam'a-risk: (1) אֶשֶׁל, 'ēshel (Gen 21 33, AV "grove," m "tree"; 1 S 22 6, AV "tree," m "grove"; 1 S 31 13, AV "tree"). The RV tr is due to the similarity of 'ēshel to the Arab. 'āthl, "the tamarisk." (2) עֲרֵעָר, 'ar'ār (Jer 17 6 m [cf 48 6], EV "heath" [q.v.]). The tamarisk (*Tamarix*, with various species in Pal, chiefly *T. Syriaca*) is a very characteristic tree of Pal, esp. in the Maritime Plain, near the sea itself, and in the Jordan valley. Eight species are described. They are characterized by their brittle, feathery branches and by their tiny scale-like leaves. Some varieties flourish not infrequently in salty soil unsuited to any ordinary vegetation.

E. W. G. MASTERMAN

**TAMMUZ**, tam'uz, tam'mōz (תַּמְזוּז, *tammūz*; Θαμμοῦζ, *Thammoúz*):

(1) The name of a Phoen deity, the Adonis of the Greeks. He was originally a Sumerian or Bab sun-god, called Dumuzu, the husband of Ishtar, who corresponds to Aphrodite of the Greeks. The worship of these deities was introduced into Syria in very early times under the designation of Tammuz and Astarte, and appears among the Greeks in the myth of Adonis and Aphrodite, who are identified with Osiris and Isis of the Egyp pantheon, showing how widespread the cult became. The Bab myth represents Dumuzu, or Tammuz, as a beautiful shepherd slain by a wild boar, the symbol of winter. Ishtar long mourned for him and descended into the underworld to deliver him from the embrace of death (Frazer, *Adonis, Attis and Osiris*). This mourning for Tammuz was celebrated in Babylonia by women on the 2d day of the 4th month, which thus acquired the name of Tammuz (see CALENDAR). This custom of weeping for Tammuz is referred to in the Bible in the only passage where the name occurs (Ezk 8 14). The chief seat of the cult in Syria was Gebal (modern *Gebail*, Gr *Bublos*) in Phoenicia, to the S. of which the river Adonis (*Nahr Ibrahīm*) has its mouth, and its source is the magnificent fountain of Apheca (modern 'Aḩka), where was the celebrated temple of Venus or Aphrodite, the ruins of which still exist. The women of Gebal used to repair to this temple in midsummer to celebrate the death of Adonis or Tammuz, and there arose in connection with this celebration those licentious rites which rendered the cult so infamous that it was suppressed by Constantine the Great.

The name Adonis, by which this deity was known to the Greeks, is none other than the Phoen אֲדוֹן, 'Ādhōn, which is the same in Heb. His death is supposed to typify the long, dry summer of Syria and Pal, when vegetation perishes, and his return to life the rainy season when the parched earth is revived and is covered with luxuriant vegetation, or his death symbolizes the cold, rough winter, the boar of the myth, and his return the verdant spring.

Considering the disgraceful and licentious rites with which the cult was celebrated, it is no wonder that Ezekiel should have taken the vision of the women weeping for Tammuz in the temple as one of the greatest abominations that could defile the Holy House. See ADONIS.

(2) The fourth month of the Jewish year, corresponding to July. The name is derived from that of a Syrian god, identified with Adonis (Ezk 8 14). See above, and CALENDAR. H. PORTER

**TANACH**, tā'nakh (תַּנְכַּח, *ta'nākh*, תַּנְכַּח, *ta'anākh*). See TAANACH.

**TANHUMETH**, tan-hū'meth (תַּנְחֻמֶת, *tanhumeth*): One of those who were left in Judah by

Nebuchadnezzar under the governorship of Gedaliah (2 K 25 23; Jer 40 8).

**TANIS**, tā'nis (Τάνις, *Tánis* [Jth 1 10]). See ZOAN.

**TANNER**, tan'ēr (βουρεύς, *burseús*, from βύρα, *búrsa*, "a hide"): The only references to a tanner are in Acts 9 43; 10 6.32. The Jews looked upon tanning as an undesirable occupation and well they



Dipping Skins in Vats of Sumach.

might, for at best it was accompanied with unpleasant odors and unattractive sights, if not even ceremonially unclean. We can imagine that Simon the tanner found among the disciples of Jesus a fellowship which had been denied him before. Peter made the way still easier for Simon by choosing his house as his abode while staying in Joppa. Simon's house was by the seashore, as is true of the tanneries along the Syrian coast today, so that the foul-smelling liquors from the vats can be drawn off with the least nuisance, and so that the salt water may be easily accessible for washing the skins during the tanning process. These tanneries are very unpretentious affairs, usually consisting of one or two small rooms and a courtyard. Within are the vats made either of stone masonry, plastered within and without, or cut out of the solid rock. The sheep or goat skins are smeared on the flesh side with a paste of slaked lime and then folded up and allowed to stand until the hair loosens. The hair and fleshy matter are removed, the skins are plumped in lime, bated in a concoction first of dog dung and afterward in one of fermenting bran, in much the same way as in a modern tannery. The bated skins are tanned in sumach (Arab. سَمَانِي, *summāḩī*), which is the common tanning material in Syria and Pal. After drying, the leather is blackened on one side by rubbing on a solution made by boiling vinegar with old nails or pieces of copper, and the skin is finally given a dressing of olive oil. In the more modern tanneries *dégras* is being imported for the currying processes. For dyeing the rams' skins red (Ex 25 ff) they rub on a solution of *kermes* (similar to cochineal; see DYEING), dry, oil, and polish with a smooth stone.

Pine bark is sometimes used for tanning in Lebanon. According to Wilkinson (*Ancient Egypt*, II, 186), the Arabs use the juice of a desert plant for dehairing and tanning skins. The skins for pouches are either tawed, i.e. tanned with a mineral salt like alum, or treated like parchment (see PARCHMENT). About Hebron oak branches, chopped into small chips, are used for tanning the leather bottles or water skins. In this case the hair is not removed. The tanning is accomplished, after removing the fleshy matter, by filling the skin with oak chips and water, tying up all openings in the skins, and allowing them to lie in the open on their "backs," with "legs" upright, for weeks. The field near Hebron

where they arrange the bulging skins in orderly rows during the tanning process presents a weird sight. These are the bottles referred to in AV (RV "skins") (Josh 9 4.13; Hos 7 5; Mt 9 17; Mk 2 22; Lk 5 37).

Leather was probably used more extensively than any records show. We know that the Egyptians used leather for ornamental work. They understood the art of making stamped leather. The sculptures give us an idea of the methods used for making the leather into sandals, trimmings for chariots, coverings of chairs, decorations for harps, sarcophagi, etc. There are two Bib. references to leather, where leathern girdles are mentioned (2 K 1 8; Mt 3 4). See also CRAFTS, II, 17.

JAMES A. PATCH

N.W. of the territory of Judah. Tristram suggested identification with 'Artuf, about 1½ miles S.E. of Zorah. G. A. Smith places it in *Wady el-'Afranj*, possibly identifying it with *Tuffuh*, fully 4 miles W. of Hebron. This position, however, is not in the Shephelah. The place probably represents "Beth-tappuah" of Josh 15 53. No quite satisfactory identification has yet been suggested.

(3) A place on the border between Ephraim and Manasseh (Josh 16 8). "The land of Tappuah," i.e. the land adjoining the town, belonged to Manasseh, but the town itself belonged to Ephraim (17 8). En-tappuah was probably a neighboring spring. Tappuah was to the S. of Michmethath, and the border ran from here westward to the brook Kanah. Some would place it at *Khirbet 'Atuf*, about 11 miles



DRESSING HIDES IN A SYRIAN TANNERY.

**TAPESTRY**, tap'es-tri (מִרְבְּדִים, *marbhaddim*, from רָבַד, *rābhadh*, "to spread"): "Carpets of tapestry" are mentioned in Prov 7 16; 31 22. We have no means of knowing just what form of weaving is here referred to. See WEAVING.

**TAPHATH**, tā'fath (תַּפְתָּח, *tāphath*): Daughter of Solomon and wife of Ben-abinadab (1 K 4 11).

**TAPHON**, tā'fon. See TEPHON.

**TAPPUAH**, tap'ū-a, ta-pū'a (תַּפְּוֹהַ, *tappūh*, "apple"):

(1) A royal city of the Canaanites, the king of which was slain by Joshua (12 17). It is named between Beth-el and Hopher, and may possibly be identical with the city named in Josh 16 8; see (3) below. There is nothing to guide us to a decision.

(2) (Omitted by LXX.) A city in the Shephelah of Judah (Josh 15 34). It is named between Engannim and Enam in a group of cities that lay in the

N. E. of *Nāblus*. More probably it should be sought to the S.W. of the plain of *Makhneh* (Michmethath). It may be identical with Tephon, which, along with Timnath, Pharathon, and other cities, Bacchides fortified "with high walls and gates and bars" (1 Macc 9 50). No identification is possible.

W. EWING

**TAPPUAH** (תַּפְּוֹהַ, *tappūh*; B, Θαπούς, *Thapous*, A, Θαφφού, *Thaphphou*, Luc., Φεθρούθ, *Phethroúth*): A "son" of Hebron (1 Ch 2 43).

**TARAH**, tā'ra, tár'a (Nu 33 27 f AV). See TERAH.

**TARALAH**, tar'a-lā (תַּרְאֵלָה, *tar'ālāh*; B, Θαραλά, *Tharela*, A, Θαραλά, *Tharalá*): A town in the territory of Benjamin named between Irpeel and Zelah (Josh 18 27). *Onom* (s.v. "Therama") simply says it was in the tribe of Benjamin. In the times of Eusebius and Jerome, therefore, the site was already lost, and has not since been recovered.

**TAREA**, tār'ē-a, ta-rē'a (תָּרְעָא, ta'ārē'a, a copyist's mistake [1 Ch 8 35] for תָּהָרְעָא, tahārē'a, "the shrewd one," in 1 Ch 9 41; B, Θεπέε, Therée, A, Θαπέε, Tharée, Luc., Θαπάα, Tharāa; in 1 Ch 9 41, B, Θαπάχ, Tharāch, A, Θαπά, Tharā, Luc., Θαπάα, Tharāa; see TAHEEA): A descendant of Saul mentioned in a genealogy of Benjamin (1 Ch 9 41).

**TARES**, tārz (ζιζάνια, zizania [Mt 13 25 ff], m "darnel"): *Zizania* is equivalent to Arab. *zuwān*, the name given to several varieties of darnel of which *Lolium temulentum*, the "bearded darnel,"



Bearded Darnel (*Lolium temulentum*).

is the one most resembling wheat, and has been supposed to be degenerated wheat. On the near approach of harvest it is carefully weeded out from among the wheat by the women and children. *Zuwān* is commonly used as chickens' food; it is not poisonous to human beings unless infected with the mold ergot.

**TARGET**, tār'get. See MARK.

**TARGUM**, tār'gum (תַּרְגּוּם, targūm):

1. Meaning and Etymology of the Term
2. Origin of the Targums
3. Language of the Targums
4. Mode in Which the Targums Were Given
5. Date of the Targums
6. Characteristics of the Different Targums
  - (1) Onkelos—the Man  
Characteristics of His Targum
  - (2) Jonathan ben Uzziel—the Man  
Characteristics of His Targum—Earlier Prophets;  
Later Prophets
  - (3) Hagiographa: Psalms, Job and Proverbs
    - (a) The *M<sup>g</sup>hillōth*
    - (b) Chronicles
  - (4) The Non-official Targums—Jonathan ben Uzziel  
and the Pentateuch
7. Use of the Targums

LITERATURE

The Targums were explanations of the Heb Scriptures in Chaldaic (Western Aram.) for the benefit of those Jews who had partially or completely ceased to understand the sacred tongue.

By Gesenius the word *m<sup>t</sup>hurgām*, which occurs in Ezr 4 7, is interpreted as derived from *rāgham*, "to pile up stones," "to throw," hence "to

**1. Meaning and Etymology of the Term** stone," and then "to translate," though no example is given. Jastrow derives it from the Assy *r-g-m*, "to speak aloud," an etymology which suits the origin of the Tgs. It is unfortunate that he gives no reference to any Assy document.

The word *turgamanu* is found, e.g., in the Am Tab (Berlin ed, 21, l. 25, Knudtzon, 154), with the meaning "interpreter." It may, none the less, be of Aram. origin. See Muss-Arnolt, *Concise Dict. Assy Language*, 1191f, and the references there given.

The word is used as the Aram. interpretation of *shiggāyōn* (Ps 7 1), a term the precise force of which is yet unfixed. From this *rāgham* comes *m<sup>t</sup>hurgāmān*, "an interpreter," and our modern "dragoman." Whatever the original meaning of the root, the word came to mean "to translate," "to explain."

At the time when Nebuchadnezzar carried the inhabitants of Jerus and Judah captive to the banks of the Tigris and the Euphrates,

**2. Origin of the Targums** the language of everyday life in Assyria and Babylonia had ceased to be that which has come down to us in the cuneiform inscriptions, and had become

Aram., the *lingua franca* of Southwestern Asia. It was the language of diplomacy, of business and of social intercourse, and had long been so. Dwelling in the midst of those who used Aram. alone, the Jews soon adopted it for every occasion save worship. In the family they might retain their mother tongue for a time, but this would yield at length to continuous pressure from without. In Pal a similar process had been going on in the absence of the captives. Intruders from various neighboring peoples had pressed in to occupy the blanks left by the removal of the Jewish captives to Babylon. Although it is not recorded, it is not impossible that following the example of the Assyrians, Nebuchadnezzar may have sent into Judaea compulsory colonists from other parts of his empire. The language common to all these, in addition to their native dialect, was Aramaic. The Jewish inhabitants that had been left in the land would, like their relatives in Babylonia, have become accustomed to the use of Aram., to the exclusion, more or less complete, of Hebrew. Another process had begun among the captives. Away from the site of their destroyed temple, the exiles did not, like those in Upper Egypt, erect another temple in which to offer sacrifices. Their worship began to consist in the study of the Law in common, in chanting of the Psalms and united prayers. This study of the Law implied that it should be understood. Though some form of synagogue worship was known in the times preceding the captivity under the direction probably of the prophets (2 K 4 23), it must have become weak and ineffective. With the arrival of Ezra there was a revival of the study of the Law, and with that the necessity for the interpretation of it in language which the people could understand.

From the facts above narrated, this language was of necessity Aramaic. There were, however, forces at work to modify the language. A

**3. Language of the Targums** tr is liable to be assimilated so far, to the language from which it is made. Thus there is a difference, subtle but

observable, between the Eng. of our AV of the Bible and that of Shakespeare, Bacon, or even Hooker. Or, to take an example more cognate, if less accessible to the general reader, the difference may be seen if one compares the Syr of the NT Pesh with that of the Pesh of the OT. The Aram. of the Tgs is Western Aram., but it is Western Aram. tintured with Hebrew. The fact that the returned

captives originally had spoken Heb would doubtless have its effect on their Aramaic. German in Jewish lips becomes Yiddish. One very marked feature is the presence of *yath*, the sign of the accusative translating the Heb 'ēh, whereas in ordinary Aram., Eastern and Western, this is unused, except as supporting the oblique case of pronouns. Further, the intensive construction of infinitive with finite sense, so frequent in Heb, though little used in ordinary Aram., appears in the Tgs wherever it occurs in the Heb text. As a negative characteristic there is to be noted the comparative rarity with which the emphatic repetition of the personal pronoun, so frequent in ordinary Aram., occurs in the Targumic.

The account given in Neh (8 8) of the reading of the Law to the people not only mentions that Ezra's helpers read "distinctly" (*m'phōrāsh*), but "gave the sense" (*sōm sekhel*) "and which caused them to understand the reading," AV (*wayyābhīnū ba-mikrā*). This threefold process implies more than merely distinct enunciation. If this passage is compared with Ezr 4 18 it would seem that *m'phōrāsh* ought to mean "interpreted." The most natural explanation is that alongside of the readers of the Law there were interpreters, *m'turgh'mānīm*, who repeated in Aram. what had been read in Heb. What interval separated this public reading of the Law from the reading of the Law as a portion of synagogue worship we have no means of knowing. The probability is that in no long time the practice of reading the Law with an Aram. interpretation was common in all Jewish synagogues. Elaborate rules are laid down in the Talm for this interpretation; how far these were those actually used we cannot be absolutely certain. They at least represent the ideal to which after-generations imagined the originators of the practice aspired. The Law was read by the reader verse by verse, and each verse was followed by a recitation by the *m'turgh'mān* of the Aram. version. Three verses of the prophetic books were read before the Aram. was recited. The Talmudists were particular that the reader should keep his eye on the roll from which he read, and that the *m'turgh'mān* should always recite his version without looking at any writing, so that a distinction should be kept between the sacred word and the version. At first the Tg was not committed to writing, but was handed down by tradition from *m'turgh'mān* to *m'turgh'mān*. That of the Law became, however, as stereotyped as if it had been written. So to some extent was it with the Prophets and also the Psalms. The Tgs of the rest of the *K'thūbhīm* seem to have been written from the beginning and read in private.

We have assumed that the action of Ezra narrated in Neh 8 8 implied not only the reading of the Law, but also the interpretation of its language—its tr in fact from Heb to Aram., and that, further, this practice was ere long followed in all the synagogues in Judaea. This view is maintained by Friedmann (*Onkelos u. Akylas*, 1896) and was that assumed to be correct by the Talm. Dr. Dalman assures his readers that this is a mistake, but without assigning any reasons for his assertion. Dr. Dalman is a very great authority, but authority is not science, so we venture to maintain the older opinion. The fact is undeniable that, during the Pers domination all over South-western Asia, Aram. was the *lingua franca*, so much so that we see by the Assouan and Elephantine papyri the Jewish garrison at Assouan in Egypt wrote to their co-religionists in Judaea, and to the Pers governors, in Aramaic. Moreover, there is no

trace that they used any other tongue for marriage contracts or deeds of sale.

We may assume that in Judaea the language commonly used in the 5th cent. BC was Aramaic. We may neglect then the position of Mr. Stenning (*Enc Brit* [11th ed], XXVI, 418b) that "probably as early as the 2d cent. BC the people had adopted Aramaic." By that time Aram. was giving place to Greek. His reason for rejecting the position above maintained is that the dates assigned by criticism to certain prophetic writings conflict with it—a mode of reasoning that seems to derive facts from theories, not theories from facts.

The fact that the necessity for tr into Aram. existed in the Pers period implies the existence of the *m'turgh'mān* and the *targum*. It is more difficult to know when these Tgs were committed to writing. It is probable that the same movement, which led Jehūdāh ha-Nāsī' to commit to writing the decisions of the rabbis which form the Mish, would lead to writing down the Tgs—that is to say late in the 2d cent. of our era. Aram. was disappearing in Pal and the traditional renderings would be liable to be forgotten. Talmudic stories as to dates at which the various Tgs were written down are absolutely valueless.

The Tgs that require most to be considered are the official Tgs, those that are given in the rabbinic Bibles in columns parallel with the columns of Hebrew. In addition, there is for the Law the *Targum Y'rūshalīmī*, of another version of which is called *Different Targum Yōnāthān ben Uzziel*. The Book of Est has two Tgs. Besides these, Tgs of doubtful value have been

written by private individuals. Certain books have no official Tgs: Dnl, Ezr, Neh and Ch. The reason for this is supposed to be that in both Dnl and Ezr there are portions written in Aramaic. Neh and Ch were regarded as forming one book with Ezr. A late Tg on Ch has been found and published separately. Some of the apocryphal additions to Est appear in a late Tg to that book. The official Tgs of the Law and the Prophets approach more nearly the character of tr<sup>s</sup>, though even in them verses are at times explained rather than tr<sup>d</sup>. The others are paraphrastic to a greater or less degree.

(1) *Onkelos*.—This is the name given to the official Tg of the Pent. The legend is that it was written by one Onkelos, a proselyte son of Kalonymus or Kalonikus, sister's son of Titus. He was associated with the second Gamaliel and is represented as being even more minutely punctilious in his piety than his friend. The legend goes on to say that, when he became a proselyte, his uncle sent company after company of soldiers to arrest him, but he converted them, one after another. It is at the same time extremely doubtful whether there ever was such a person, a view that is confirmed by the fact that legends almost identical are related of Aquila, the translator of the Heb Scriptures into Greek. The names are similar, and it may be are identical. While there may have been a person so named, the admission of this does not imply that he had any connection with the Tg of the Pent named after him. Another explanation is that as the Gr version of Aquila was much praised by the Jews for its fastidious accuracy, and this Tg of the Law was credited with equally careful accuracy, so all that is meant is that it was regarded as a version which as accurately represented in Aram. the Heb of the Law as did Aquila's Greek. The probability is that whoever it was who committed the Tg to writing did little or no actual translating. It might not be the work of one unassisted author; the reference to the guidance Onkelos is alleged to have received from the rabbi Eliezer and Joshua suggests this. Owing to the fact that the Law was read through in the course of a year in Bab (once in

three years in Pal) and every portion interpreted verse by verse in Aram., as it was read, the very words of the traditional rendering would be remembered. This gives the language of the Tg an antique flavor which may be seen when it is compared with that of the Palestinian lectionary discovered by Mrs. Gibson and Mrs. Lewis. Esp. is this observed when the renderings of the same passage are put in comparison. Both in vocabulary and grammar there is a difference; thus *mār* occurs for *shallēt*, and *yath* as the sign of the accusative has disappeared in the lectionary. An analogy may be seen in the antique flavor of the language of our Eng. Bible, even in RV. If any credence were to be given to the traditional account of the alleged authors, the date of this Tg would be the end of the 1st cent. AD. But we have seen that it has been named Aquila and that the title means "as accurate as Aquila." He, however, lived in the beginning of the 2d cent. His Gr version must have already gained a reputation before the Aram. Tg appeared. We cannot therefore date the actual committing of this Tg to writing earlier than late in the 2d cent., not improbably, as suggested above, contemporary with the writing down of the Mish by Jehūdāh ha-Nāsī'.

The characteristics of this Tg are in general close adherence to the original, sometimes even to the extent of doing violence to the genius of the language into which it has been tr<sup>d</sup>. One prominent example of this is the presence of *yath* as the sign of the accusative; and there is also the intensive construction of infinitive with finite tense. There is a tendency to insert something between God and His worshipper, as "*mīm'ā* Jeh" instead of simply "Jeh." Where anthropomorphisms occur, an exact tr is not attempted, but the sense is represented in an abstract way, as in Gen 11 5, where instead of "The Lord [YHWH] came down" there is "The Lord [*yivā*]" was revealed." At the same time there is not a total avoidance of paraphrase. In Gen 4 7 the Tg renders, "If thou doest thy work well, is it not remitted unto thee? if thou doest not thy work well, thy sin is reserved unto the day of judgment when it will be required of thee if thou do not repent, but if thou repent it shall be remitted to thee." It will be observed that the last clause of the Heb is omitted. So in Gen 3 22, instead of "Man has become as one of us," Onkelos writes "Man has become alone in the world by himself to know good and evil." A more singular instance occurs in Gen 27 13, where Rebekah answers Jacob, "Upon me he thy curse, my son"; in the Tg it is, "Unto me it hath been said in prophecy, there shall be no curse upon thee my son." Sometimes there is a mere explanatory expansion, as in Ex 3 1, where instead of "the mount of God," Onkelos has "the mountain on which the glory of the Lord was revealed." In the mysterious passage, Ex 4 24-26, later Jewish usage is brought in to make an easy sense. "And it was on the way in the inn [house of rest] that the angel of the Lord met him and sought to slay him. And Zipporah took a flint knife and cut off the foreskin of her son and came near before him and said 'In the blood of this circumcision is the bridegroom given back to us,' and when therefore he had desisted she said, 'Had it not been for the blood of this circumcision the bridegroom would have been condemned to die.'" Here *hāhān* ("bridegroom") is used according to later custom of the child to be circumcised. Sometimes reasons of propriety come in, as when the sin of Onan is described "corrupting his way on the earth." It is, however, in the poetical passages that the writer gives loose rein to paraphrase. As an example the blessing of Judah in Jacob's blessing of his sons may be given: "Judah, thou art praise and not shame; thee thy brethren shall praise. Thy hands shall be strong upon thine enemies, those that hate thee shall be scattered; they shall be turned back before thee; the sons of thy father shall come before thee with salutations. [Thy] rule shall be in the beginning, and in the end the kingdom shall be increased from the house of Judah, because from the judgment of death, my son, thy soul hast thou removed. He shall rest, he shall abide in strength, as a lion and as a lioness there is nothing may trouble him. The ruler shall not depart from the house of Judah nor the scribe from his son's sons for ever till the Messiah come whose is the kingdom and whom the heathen shall obey. Israel shall trade in his cities, the people shall build his temple, the saints shall be going about to him and shall be doers of the Law through his instruction. His raiment shall be goodly crimson; his clothing covering him, of wool dyed bright with colours. His mountains shall be red with his vineyards, his hills shall flow down with wine, and his valleys shall be white with corn and with flocks of sheep."

Committed to writing in Pal, the Tg of Onkelos

was sent to Babylon to get the *imprimatur* of the famous rabbis residing there. There are said to be traces in the language of a revision by the Bab teachers, but as this lies in the prevalence of certain words that are regarded as more naturally belonging to Eastern than Western Aram., it is too restrictedly technical to be discussed here. The result of the Bab sanction was the reception of this Tg as the official interpretation of the books of the Law. It seems probable that the mistake which led to its being attributed to Onkelos was made in Babylon where Aquila's Gr version was not known save by vague reputation.

(2) *The Tg of Jonathan ben Uzziel on the Prophets.*—This Jonathan, to whom the Tg on the Prophets is attributed, is declared to be one of the most distinguished pupils of Hillel. The prophetic section of the Bible according to the Jews contains, besides what we ordinarily reckon prophetic books, also all the earlier historical books except Ruth, which is placed among the Hagiographa. During the persecution of the Jews by Epiphanes, when the Law was forbidden to be read in the synagogue, portions of the Prophets were read instead. There was no attempt to read the whole of the Prophets thus, but very considerable portions were used in worship. This necessitated the presence of the *m'turgh'mān*. If one might believe the Talmudic traditions, Jonathan's Tg was committed to writing before that of Onkelos. Jonathan is regarded as the contemporary of the first Gamaliel, whereas Onkelos is the friend of Akiba, the contemporary of Hadrian. The tradition is that when he published his Tg of the Prophets, all Pal was shaken, and a voice from heaven was heard demanding, "Who is this who revealeth my secrets to the sons of men?" As an example of the vagueness of Talmudic chronology, it may be mentioned that Jonathan was said to have made his Tg under the guidance of Haggai, Zechariah and Malachi. He is said to have desired to write a Tg of the *K'thūbhīm*, but was forbidden by a voice from heaven. The Tg of Job was said to have been already written, but was buried by Gamaliel. It is said to have been exhumed and that the present Tg on that book is from Jonathan's hand. The tomb of Jonathan ben Uzziel is shown on the face of a hill to the N. of *Safed*, Palestine.

In the former Prophets—the historical books—the style does not differ much from that of Onkelos. Occasionally there are readings followed which are not in the MT, as Josh 8 12, where the Tg has "the west side of Ai" instead of as in the MT, "the west side of the city." Sometimes two readings are combined, as in 8 16, where the MT has "all the people which were in the city," the Tg adds "in Ai." Again, the Tg translates proper names, as, in Josh 7 5, "Shebarim" (*sh'bhārim*) is rendered "till they were scattered." Such are the variations to be seen in the narrative portion of the Tg of the earlier Prophets. When, however, a poetical piece occurs, the writer at times gives rein to his imagination. Sometimes one verse is exceedingly paraphrastic and the next an accurate rendering without any addition. In the song of Deborah (Jgs 5) the 1st verse has only a little of paraphrase: "Then sang praises Deborah and Barak the son of Abinoam on account of the lifting up and deliverance which had been wrought in that day, saying . . ." The verse which follows is very paraphrastic; instead of the 7 words of the verse in the MT the Tg has 55. It is too long to quote in full, but it begins, "Because the house of Israel rebelled against His Law, the Gentiles came up upon them and disturbed their assemblies, and because they refused to obey the Law, their enemies prevailed against them and drove them from the borders of the land of Israel," and so on, Sisera and all his host being introduced. Ver 3 reads thus, "Hear O kings who are with him, with Sisera for war, who obey the officers of Jabin the king of Canaan; with your might and your valour ye shall not prevail nor go up against Israel, said I Deborah in prophecy before the Lord. I will sing praise and bless before Jeh the God of Israel."

The later prophets are more paraphrastic as a whole than the earlier, as having more passages



with poetic metaphors in them—a fact that is made plain to anyone by the greater space occupied in the rabbinic Bibles by the Tgs of the Prophets. A marked example of this tendency to amplify is to be found in Jer 10 11: "Thus shall ye say unto them, The gods that have not made the heavens and the earth, these shall perish from the earth, and from under the heavens." As this verse is in Aram. it might have been thought that it would have been transferred to the Tg unchanged, but the Targumist has made of the 10 words of the original text 57. Sometimes these expansions may be much shorter than the above example, but are illuminative, showing the views held by the Jewish teachers. In Isa 29 1, "Ho Ariel, Ariel, the city where David encamped!" the Tg has "Woe to the altar, the altar which David built in the city in which he dwelt." In this rendering we see the Jewish opinion that "Ariel," which means "Lion of God," in this connection stood for the "altar" which David erected in Jerus. It seems unlikely that this whole Tg was the work of one writer, but the style gives little indication of difference. The paraphrase of the synagogal *haphṭārōth* being traditional, the style of the person who committed it to writing had little scope. The language represents naturally an older stage of development than we find in the contemporary Christian lectionaries. As only portions of the Prophets were used in synagogue worship, only those portions would have a traditional rendering; but these fixed the style. In the RV of the Apoc the 70 verses which had been missing from 2 Esd 7 are tr<sup>d</sup> in the style adopted by the translators under King James. It is impossible to fix the date at which the Tg of any of the prophetic books was written down. It is probable that it was little if at all after that of Onkelos. The completion of the paraphrases of the prophetic writings, of which only portions were used in the synagogue, seems to imply that there were readers of the Aram. for whose benefit those Tgs were made.

(3) The Tgs of the third division of the Heb sacred writings, the *K'thūbhīm* (the Hagiographa), are ascribed to Joseph Caecus, but this is merely a name. There is no official Tg of any of the Hagiographa, and several of them, Dnl, Neh and Ezr, as above noted, have no Tg at all. Those of the longer books of this class, Pss, Prov and Job, are very much closer to the text than are the Tgs of the *M'ghillōth*. In the Pss, the paraphrase is explanatory rather than simply expansive. Thus in Ps 29 1, "ye sons of the mighty" is rendered "ye companies of angels, ye sons of the mighty." Ps 23 is further from the text, but it also is exegetic; instead of "Jeh is my shepherd, I shall not want," the Tg reads, "The Lord nourished His people in the wilderness so that they lacked nothing." So the last clause of the last verse of this ps is, "I shall indeed dwell in the house of the holiness of the Lord for the length of days." Another example of exegesis is Ps 46 4, in which the "river whose streams make glad the city of our God" is explained as "the nations as rivers making glad the city of Jeh." Much the same may be said of Job, so examples need not be given.

The Tg of Prov has been very much influenced by the Pesh; it may be regarded as a Jewish recension of it. Those of the five *M'ghillōth*, as they are called, Song of Songs, Ruth, Lam, Eccl, and Est, are excessively paraphrastic. If one compare the space occupied by the text of Cant and Prov, it will be found that the former occupies about one-sixth of the latter; if the Tgs of the two books are compared in Lagarde's text, the Cant is two-thirds of Prov. So Lam occupies in the MT less than a quarter the space which Prov occupies; but the Tg of Lam is two-fifths the size of the Tg of Prov.

Ruth has not suffered such a dilatation; in the text it is a fifth, in the Tg a fourth, the size of Prov. The expansion mainly occurs in the first verse in which ten different famines are described. Eccl in the MT uses about three-eighths of the space occupied by Prov. This is increased to five-sixths in the Tg. There are two Tgs of Est, the first about five-sixths the size of Prov, the second, nearly double. The text is under one-half. We subjoin the Tg of Lam 1 1 from Mr. Greenup's tr: Jeremiah the prophet and high priest said: "How is it decreed against Jerus and against her people that they should be condemned to exile and that lamentation should be made for them? How? Just as Adam and Eve were condemned who were ejected from the garden of Eden and over whom the Lord of the universe lamented. How? God the judge answers and speaks thus: 'Because of the multitude of the sins which were in the midst of her, therefore she will dwell alone as the man in whose flesh is the plague of leprosy dwells alone! And the city that was full of crowds and many people hath been deserted by them and become like a widow. And she that was exalted among the peoples and powerful among the provinces, to whom they paid tribute, hath been scattered abroad so as to be oppressed and to give tribute to them after this.'" This gives a sufficient example of the extent to which expansion can go. Ver 1 of Est in the first Tg informs us that the cessation of the work of building the Temple was due to the advice of Vashti, and that she was the daughter of Evil-merodach, the son of Nebuchadnezzar, and a number of equally accurate pieces of information. Yet more extravagant is the 2d Tg; it begins by asserting that there are ten great monarchs of whom Achhashverosh was the 6th, the Gr and Rom were the 7th and the 8th, Messiah the king the 9th, and the Almighty Himself the 10th. It evidently has no connection with the first Tg. The Tg of Ch, although late, is modeled on the Tgs of Jonathan ben Uzziel. In cases where the narrative of Ch runs parallel with that of S the resemblance is very great, even to verbal identity at times. The differences sometimes are worthy of note, as where in 1 Ch 21 2, instead of "Dan" the Tg has "Pameas" (Pameas), which affords an evidence of the lateness of this Tg. In the rabbinic Bible, Ch appear, as do Ezr, Neh and Dnl, without a parallel Tg.

(4) There is a Tg on the Pent attributed to Jonathan ben Uzziel which is very paraphrastic. Fragments of another closely related Tg have been preserved, known as the Jerus Tg. In fact the two may really be regarded as different recensions of the same Tg. It is supposed that some MS was denominated simply "the targum of J," which, really being the initial representing "Jerusalem," was taken as representing "Jonathan." At the end of each of the books of the Pent it is stated that this Tg is the "targum *Y'rūshalmī*." Of the two the *Y'rūshalmī* is the longer. Both assert that five signs accompanied Jacob in his stay in Haran: the time was shortened; the distance was shortened; the four stones for his pillow became one; his strength was increased so that with his own arm he moved the stone covering the well which it took all the shepherds to move; the water gushed from the well all the days he dwelt in Haran. But the narrative of ben Uzziel is expanded to nearly twice the length in the *Y'rūshalmī*. This Tg may be regarded as to some extent semi-official.

As the Tgs appear to have been committed to writing after the MT was fixed, textual differences are few and unimportant. Kohn mentions that in a few cases Onkelos agrees with the Sam against the MT; they are, however, few, and possibly may be explained by differences of idiom, though from the slavish way in which Onkelos follows the Heb text this is improbable. The Pal Tg agrees with the Sam and the VSS in adding "Let us go into the field" in Gen 4 8. The main benefit received from the Tgs is the knowledge

of the views of the Jewish rabbis as to the meaning of certain passages. Thus in Gen 49 10 there is no doubt in the mind of the Targumist that "Shiloh" refers to the Messiah. Some other cases have been noted above. The frequency with which the word of the Lord (*mām'ra' y'ya'*) is used in Onkelos as equivalent to Y H W H, as Gen 3 8, "They heard the voice of the word of the Lord God," *mām'ra' dh'y'ya' 'Ēloh'im*, requires to be noted from its bearing on Christian theology. There is a peculiar usage in Gen 15 1: Y H W H says to Abraham, "Fear not, Abram, my word [*mām'ra'*] shall help thee." Pharaoh is represented as using this periphrasis: "The word of the Lord [*mām'ra' y'ya'*] be for your help when I send away you and your little ones" (Ex 10 10). A striking use of this phrase is to be found in Dt 33 27, where instead of "Underneath are the everlasting arms," we have "By His word the world was made." This is at once seen to resemble the usage of Philo and the apostle John. As the Tgs had not been committed to writing during the lifetime of either of these writers, it might be maintained that the Targumists had been influenced by Philo. This, however, does not follow necessarily, as both apostle and philosopher would have heard the Tg of the Law recited Sabbath after Sabbath from their boyhood, and the phrase *mām'ra' y'ya'* would remain in their memory. The Tgs of the pseudo-Jonathan and that of Jerus have a yet more frequent use of the term. Edersheim has counted 176 occurrences of the phrase in Onkelos and 321 in that of the pseudo-Jonathan and in the fragments of the *Y'rushalmi* 99. This is made the more striking by the fact that it rarely occurs in the rest of Scripture. In Am 1 2, instead of "Jeh . . . will utter his voice from Jerus," we have "From Jerus will He lift up His word" (*mēm'rih*). The usual equivalent for the prophet's formula "the word of the Lord" is *pihgām Y H W H*. An example of the usage before us may be found in Ps 56 4.10: "In the righteousness of the judgment of God will I praise his word" (*mēm'rih*). There was thus a preparation for the Christian doctrine of the Trinity imbedded in the most venerated Tg, that of the Law.

LITERATURE.—The text of the official Tgs is to be found in every rabbinic Bible. Berliner has published a careful, vocalized edition of Onkelos. The Prophets and the Hagiographa have been edited by Lagarde, but unvocalized. For the language Petermann's grammar in the *Porta Linguarum Orientalium* is useful. Levy's *Challdaisches Wörterbuch* is very good. Jastrow's *Dict. of the Targumim* is invaluable. Brextorf's *Lexicon Talmudicum* supplies information not easily available elsewhere. The Tgs on the Pent have been tr'd by Etheridge. There is an extensive lit. on this subject in German. In Eng. the different Bible Dicts. may be consulted, esp. McClintock, *DB*, *HDB*, *EB*, etc. The art. in *Enc Brit* is worthy of study, as also naturally that in the *Jew Enc*.

J. E. H. THOMSON

**TARPELITES**, tār'pel-its (אֲרַפְלָיִם, *tarp'layē'* [Ezr 4 9]): Various theories have been advanced as to the identity of the Tarpeletes. Rawlinson suggested the Tuplai, which name appears in the inscriptions as equivalent to the Gr *Τιβαρηνοί*, *Tibarēnoi*, a tribe on the coast of Pontus. Hitzig located them in Tripolis in Northern Phoenicia. The latest theory emends the text to אֲרַפְרָיִם, *tīphs'rayā'*, "tablet-writers" (from the Assy *dup sarru*); cf Schrader, *COT*, on Jer 51 27.

**TARSHISH**, tār'shish (תַּרְשִׁישִׁי, *tarshīsh*):

(1) Eponym of a Benjamite family (1 Ch 7 10); B, *Ραμεσσαί*, *Rhamessai*, A and Luc., *Θαρρεΐς*, *Tharsēis*.

(2) One of the "seven princes" at the court of Ahasuerus (Est 1 14 MT).

(3) The Heb name of a precious stone (Ezk 10 9 m, EV "beryl"; Ex 28 20; 39 13; Ezk 1 16;

28 13; Cant 5 14; Dnl 10 6). See STONES, PRECIOUS.

**TARSHISH, NAVY (SHIPS) OF**. See SHIPS AND BOATS, II, 1, (2).

**TARSUS**, tār'sus (Ταρσός, *Tarsós*, ethnic *Ταρσεύς*, *Tarseús*):

1. Situation
  2. Foundation Legends
  3. Tarsus under Oriental Power
  4. Tarsus under Greek Sway
  5. Tarsus in the Roman Empire
  6. The University
  7. The Tarsian Constitution
  8. Paul of Tarsus
  9. Later History
- LITERATURE

The chief city of Cilicia, the southeastern portion of Asia Minor. It lay on both banks of the river Cydnus, in the midst of a fertile alluvial plain, some 10 miles from the seacoast. About 6 miles below the city the river broadened out into a considerable lake called Rhegma (Strabo xiv.672), which afforded a safe anchorage and was in great part fringed with quays and dockyards. The river itself, which flowed southward from the Taurus Mountains with a clear and swift stream, was navigable to light craft, and Cleopatra, when she visited Antony at Tarsus in 38 BC, was able to sail in her richly decorated barge into the very heart of the city (Plut. *Ant*. 26). The silting-up of the river's mouth seems to have resulted in frequent floods, against which the emperor Justinian (527-65 AD) attempted to provide by cutting a new channel, starting a short distance N. of the city, to divert the surplus water into a watercourse which lay to the E. of Tarsus. Gradually, however, the original bed was allowed to become choked, and now the Cydnus flows wholly through Justinian's channel and passes to the E. of the modern town. Two miles N. of Tarsus the plain gives way to low, undulating hills, which extend to the foothills of Taurus, the great mountain chain lying some 30 miles N. of the city, which divides Cilicia from Lycaonia and Cappadocia. The actual frontier-line seems to have varied at different periods, but the natural boundary lies at the Cilician Gates, a narrow gorge which Tarsian enterprise and engineering skill had widened so as to make it a wagon road, the chief highway of communication and trade between Cilicia and the interior of Asia Minor and one of the most decisive factors in Anatolian history. Eastward from Tarsus ran an important road crossing the Sarus at Adana and the Pyramus at Mopsuestia; there it divided, one branch running southeastward by way of Issus to Antioch on the Orontes, while another turned slightly northward to Castabala, and thence ran due E. to the passage of the Euphrates at Zeugma. Thus the fertility of its soil, the safety and convenience of its harbor and the command of the main line of communication between Anatolia and Syria or Mesopotamia combined to promote the greatness of Tarsus, though its position was neither a healthful or a strong one and the town had no acropolis.

Of the foundation of the city various traditions were current in antiquity, and it is impossible to arrive at any certain conclusion, for such foundation legends often reflected the sympathies and wishes of a city's later population rather than the historic facts of its origin.

**2. Foundation Legends**  
At Anchiale, about 12 miles S.E. of Tarsus, was a monument commonly known as the tomb of Sardauapalus, king of Assyria, bearing an inscription "In Assy letters" stating that that monarch "built Anchiale and Tarsus in a single day" (Strabo xiv. 672; Arrian *Anab*. ii.5). The statement of Alexander Polyhistor, preserved by Eusebius (*Chron*. i, p. 27, ed Schoene), that Sennacherib, king of Nineveh (705-681 BC), founded the city, also ascribes to it an Assy origin.

On the other hand, the Greeks had their own traditions, claiming Tarsus as a Gr or semi-Gr foundation. Strabo says that it owed its rise to the Argives who with Triptolemus wandered in search of Io (xiv.673), while others spoke of Heracles or Perseus as the founder. It must be admitted that these tales, taken by themselves, give us little aid.

Ramsay believes that Tarsus existed from time immemorial as a native Cilician settlement, to which was added, at some early date unknown to us, a body of Ionians, which migrated from the western coast of Asia Minor under the auspices and direction of the oracle of Clarian Apollo near Colophon. The earliest historical

record of the town is found on the Black Obelisk of Shalmaneser, about 850 BC, where it figures among the places captured by that king. It is thus proved that Tarsus already existed at that remote date. For many centuries it remained an oriental rather than a Hellenic city, and its history is almost a blank. After the fall of the Assyrian empire, Cilicia may have regained its independence, at least partially, but it subsequently became a province of the Persians, paying to the Great King an annual tribute of 360 white horses and 500 talents of silver (Herod. iii.90) and contributing considerable fleets, when required, to the Persians' navy. From time to time we hear of rulers named Syennesis, who appear to have been vassal princes in a greater or less degree of dependence upon the oriental empires. Two clear glimpses of the city are afforded us, thanks to the passage through it of Hellenic troops engaged upon eastern expeditions. Xenophon (*Anab.* i.2, 21 ff) tells how, in 401 BC, Cyrus the Younger entered Cilicia on his famous march against his brother Artaxerxes, and how some of his Gr mercenaries plundered Tarsus, which is described as a great and prosperous city, in which was the palace of King Syennesis. The king made an agreement with Cyrus, who, after a delay of 20 days, caused by the refusal of his troops to march farther, set out from Tarsus for the Euphrates. Again, in 333 BC, Alexander the Great passed through the Cilician Gates on his way to Issus, where he met and routed the Persian army under Darius III. Arsames, the satrap of Cilicia, failed to post a sufficient force at the pass, the garrison fled without resistance and Alexander thus entered the province without striking a blow. The Persians thereupon set fire to Tarsus, but the timely arrival of the Macedonian advance guard under Parmenio saved the city from destruction. A bath in the cold waters of the Cydnus which Alexander took while heated with his rapid advance brought on a fever which all but cost him his life (Arrian *Anab.* ii.4; Q. Curtius *Hist. Alex.* iii.4 f). For two centuries Tarsus had been the capital of a Persian satrapy, subject to oriental rather than to Hellenic influence, though there was probably a Hellenic element in its population, and its trade brought it into touch with the Greeks. The Cilician coins struck at Tarsus confirm this view. Down to Alexander's conquest, they ordinarily bear Aram. legends, and many of them show the effigy of Baal Tarz, the Lord of Tarsus; yet these coins are clearly influenced by Gr types and workmanship.

Alexander's overthrow of the Persian power brought about a strong Hellenic reaction in Southeastern

Asia Minor and must have strengthened the Gr element in Tarsus, but more than a century and a half were to elapse before the city attained that civic autonomy which was the ideal and the boast of the Gr *pólis*. After

Alexander's death in 323 BC his vast empire was soon dismembered by the rivalries and wars of his

powerful generals. Cilicia ultimately fell under the rule of the Seleucid kings of Syria, whose capital was Antioch on the Orontes. Though Greeks, they inherited certain features of the old Persian policy and methods of rule; Cilicia was probably governed by a satrap, and there was no development within

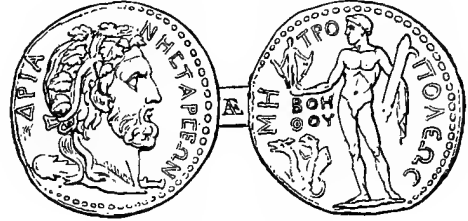

Coin of Tarsus.

it of free city life. Early in the 2d cent., however, came a change. Antiochus III, defeated by the Romans in the battle of Magnesia (190 BC), was forced to evacuate most of his possessions in Asia Minor. Cilicia thus became a frontier province and gained greatly in importance. The outcome was the reorganization of Tarsus as an autonomous city with a coinage of its own, which took place under Antiochus IV Epiphanes (175-164), probably in 171 BC. It is at this time that Tarsus is first mentioned in the Bible, unless we are to accept the disputed identification with Tarsus (q.v.). In 2 Mace 4 30 f we read that, about 171 BC, "it came to pass that they of Tarsus and Mallus made insurrection, because they were to be given as a present to Antiochus, the king's concubine. The king therefore came to Cilicia in all haste to settle matters." That this settlement took the form of a compromise and the grant to Tarsus of at least a municipal independence we may infer from the fact that Tarsus struck its own coins from this reign onward. At first they bear the name of Antioch on the Cydnus, but from the death of Antiochus this new appellation falls into disuse and the old name reasserts itself. But it is almost certain that, in accordance with Seleucid policy, this reorganization was accompanied by the enlargement of the citizen body, the new citizens in this case consisting probably of Jews and Argive Greeks. From this time Tarsus is a city of Hellenic constitution, and its coins no longer bear Aram. but Gr legends. Yet it must be remembered that there was still a large, perhaps a preponderating, native and oriental element in the population, while the coin types in many cases point to the continued popularity of non-Hellenic cults.

About 104 BC part of Cilicia became a Roman province, and after the Mithridatic Wars, during which Tarsus fell temporarily into the hands of Tigranes of Armenia, Pompey the Great reorganized the eastern portion of the Roman Empire (64-63 BC), and Tarsus became the capital of a new and enlarged province, administered by Roman governors who usually held office for a single year. Thus we find Cicero in command of Cilicia from the summer of 51 BC to the summer of the following year, and though he expressly mentions Tarsus only rarely in his extant letters of this period (e.g. *Ad Att.* v.20.3; *Ad Fam.* ii.17.1), yet there is reason to believe that he resided there during part of his year of office. Julius Caesar passed through the city in 47 BC on his march from Egypt to Pontus, and was enthusiastically received. In his honor the name Tarsus was changed to Juliopolis, but this proved no more lasting than Antioch on the Cydnus had been. Cassius tempo-

**4. Tarsus under Greek Sway**

**5. Tarsus in the Roman Empire**

rarily overawed it and imposed on it a crushing fine, but, after the overthrow of the republican cause at Philippi and the assignment of the East to Antony's administration, Tarsus received the position of an independent and duty-free state (*civitas libera et immunitis*) and became for some time Antony's place of residence. This privileged status was confirmed by Augustus after the victory of Actium had made him sole master of the Rom Empire (31 BC). It did not by itself bestow Rom citizenship on the Tarsians, but doubtless there were many natives of the city to whom Pompey, Caesar, Antony and Augustus granted that honor for themselves and, as a consequence, for their descendants.

It is under the rule of Augustus that our knowledge of Tarsus first becomes fairly full and precise.

## 6. The University

Strabo, writing about 19 AD, tells us (xiv.673 ff) of the enthusiasm of its inhabitants for learning, and esp. for philosophy. In this respect, he says, Tarsus surpasses Athens and Alexandria and every other university town. It was characterized by the fact that the student body was composed almost entirely of natives, who, after finishing their course, usually went abroad to complete their education and in most cases did not return home, whereas in most universities the students were to a large extent foreigners, and the natives showed no great love of learning. Alexandria, however, formed an exception, attracting a large number of foreign students and also sending out many of its younger citizens to other centers. In fact, adds Strabo, Rome is full of Tarsians and Alexandrians. Among the famous men who learned or taught at Tarsus, we hear of the Stoics Antipater, Archedemus, Nestor, Athenodorus surnamed Cordylion, the friend and companion of the younger Marcus Cato, and his more famous namesake (called Cananites after the village of his birth), who was the tutor and confidant of Augustus, and who subsequently reformed the Tarsian constitution. Other philosophers of Tarsus were Nestor, a representative of the Academy, and tutor of Marcellus, Augustus' nephew and destined successor, and of Tiberius, Plutades and Diogenes; the latter was also famous as an improvisatore, and indeed the Tarsians in general were famed for their ease and fluency in impromptu speaking. Artemidorus and Diodorus the grammarians and Dionysides the tragic poet, a member of the group of seven writers known as "the Pleiad," complete Strabo's list of eminent Tarsians. A less attractive view of the life in Tarsus is given by Philostratus in his biography of Apollonius of Tyana, who went there to study in the early part of Tiberius' reign (14-37 AD). So disgusted was he by the insolence of the citizens, their love of pleasure and their extravagance in dress, that he shook the dust of Tarsus off his feet and went to Aegae to pursue his studies in a more congenial atmosphere (*Vit. Apollon.* i.7). But Strabo's testimony is that of a contemporary and an accurate historian and must outweigh that of Philostratus, whose work is largely tinged with romance and belongs to the early years of the 3d cent. AD.

Strabo also tells us something of an important constitutional reform carried out in Tarsus under the Emperor Augustus, probably about

7. The Tarsian Constitution 15-10 BC. Athenodorus Cananites, the Stoic, returned to his city as an old man, after some 30 years spent at Rome, armed with authority from the emperor to reform abuses in its civic life. He found the constitution a democracy, swayed and preyed upon by a corrupt clique headed by a certain Boethus, "bad poet and bad citizen," who owed his position partly to his ready and persuasive

tongue, partly to the favor of Antony, whom he had pleased by a poem composed to celebrate the victory of Philippi. Athenodorus sought at first to mend matters by argument and persuasion, but, finding Boethus and his party obdurate, he at length exercised his extraordinary powers, banished the offenders and remodeled the constitution, probably in a timocratic mold, restricting the full citizenship to those possessed of a considerable property qualification. On his death, his place as head of the state was taken for a while by the academic philosopher Nestor (Strabo xiv.674 f). Next to Strabo's account our most valuable source of information regarding Tarsus is to be found in the two orations of Dio Chrysostom addressed to the Tarsians about 110 AD (*Orat.* xxxiii, xxxiv; see *Jour. Hell. Studies*, XXIV, 58 ff). Though admitting that the city was an Argive colony, he emphasized its non-Hellenic character, and, while criticizing much in its institutions and manners, found but a single feature to commend, the strictness with which the Tarsian women were veiled whenever they appeared in public.

Such was Tarsus, in which Paul was born (Acts 22 3) and of which he was a citizen (Acts 9 11; 21 39). Its ancient traditions and

8. Paul of Tarsus its present greatness explain and justify the pride with which he claimed to be "a citizen of no mean city"

(Acts 21 39). It is probable that his forefathers had been among the Jews settled at Tarsus by Antiochus Epiphanes, who, without sacrificing nationality or religion, became citizens of a community organized after the Gr model. On what occasion and for what service Rom *civitas* had been conferred on one of Paul's ancestors we cannot say; this only we know, that before his birth his father had possessed the coveted privilege (Acts 22 28). It is a fascinating, but an elusive, quest to trace in Paul's life and writings the influence of his Tarsian ancestry, birth and early life. Jerome, it is true, claims that many Pauline words and phrases were characteristic of Cilicia, and some modern scholars profess to find traces, in the apostle's rhetoric and in his attitude toward pagan religion and secular learning, of Tarsian influence. But such speculations are likely to be misleading, and it is perhaps best to admit that, save in the trade learned by Paul, which was characteristic of his birthplace, we cannot with any precision gauge the effects of his early surroundings. At the same time it is certain that the character of his native city, its strong oriental element, its Gr constitution and speech, its position in the Rom Empire, its devotion to learning, must have made an impression upon one who, uniting Jewish nationality with membership of a Gr state and Rom citizenship, was to be the great interpreter to the Graeco-Rom world of a religion which sprang from the soil of Judaism. How long Paul remained at Tarsus before beginning his studies in Jerus we cannot say. His own declaration that he was "born in Tarsus of Cilicia, but brought up in this city" (Acts 22 3) seems to show that his training at Jerus began at an early age, and is inconsistent with the supposition that he was one of those Tarsian students who, after studying at their native university, completed their education abroad. During his first visit to Jerus after his conversion, plots were formed against his life, and he was induced to return to Tarsus (Acts 9 30), where, according to Ramsay's chronology, he remained for some 8 years. Thither Barnabas went to seek him when he felt the need of a helper in dealing with the new problems involved in the growth of the Antiochene church and the admission into it of Gentiles in considerable numbers (Acts 11 25). Tarsus is not again mentioned in the NT,

but Paul doubtless revisited it on his second missionary journey, when he "went through Syria and Cilicia" (Acts 15 41), and traveled thence by way of the Cilician Gates into Lycaonia, and again at the beginning of his third journey when, after some time spent at Antioch, "he departed, and went through the region of Galatia, and Phrygia, in order" (Acts 18 23).

This is not the place to discuss in detail the later history of Tarsus, many passages of which are obscure and difficult. It remained a focus of imperial loyalty, as is indicated by the names Hadriane, Commodiane, Severiane and others, which appear, isolated or conjoined, upon its coins, together with the title of metropolis and such epithets as "first," "greatest," "fairest." Indeed it was chiefly in the matter of such distinctions that it carried on a keen, and sometimes bitter, rivalry, first with Mallus and Adana, its neighbors in the western plain, and later with Anazarbus, the chief town of Eastern Cilicia. But Tarsus remained the capital of the district, which during the 1st cent. of the empire was united with Syria in a single imperial province, and when Cilicia was made a separate province Tarsus, as a matter of course, became its metropolis and the center of the provincial Caesar-worship, and, at a later date, the capital of "the three eparchiae," Cilicia, Isauria and Lycaonia. Toward the close of the 4th cent. Cilicia was divided into two, and Tarsus became the capital of Cilicia Prima only. Soon after the middle of the 7th cent. it was captured by the Arabs, and for the next three centuries was occupied by them as their northwestern capital and base of operations against the Anatolian plateau and the Byzantine empire. In 965 it was recaptured, together with the rest of Cilicia, by the emperor Nicephorus Phocas, but toward the close of the following century it fell into the hands of the Turks and afterward of the Crusaders. It was subsequently ruled by Armenian princes as part of the kingdom of Lesser Armenia, and then by the Memluk sultans of Egypt, from whom it was finally wrested by the Ottoman Turks early in the 16th cent. The modern town, which still bears the ancient name in the slightly modified form *Tersous*, has a very mixed population, numbering about 25,000, and considerable trade, but suffers from its unhealthy situation and the proximity of large marshy tracts. Few traces of its ancient greatness survive, the most considerable of them being the vast substructure of a Graeco-Rom temple, known locally as the tomb of Sardanapalus (R. Koldewey in C. Robert, *Aus der Anomia*, 178 ff.).

LITERATURE.—The best account of Tarsus will be found in W. M. Ramsay, *The Cities of St. Paul* (London, 1907), 85-244; the same writer's arts. on "Cilicia, Tarsus and the Great Taurus Pass" in the *Geographical Journal*, 1903, 357 ff. and on "Tarsus" in *HDB* should also be consulted, as well as H. Böhlig, *Die Geisteskultur von Tarsos im augusteischen Zeitalter* (Göttingen, 1913). For inscriptions see LeBas-Waddington, *Voyage archéologique*, III, nos. 1476 ff.; *Inscr. Graec. ad res Rom. pertinentes*, III, 876 ff. For coins, B. V. Head, *Historia Numorum*, 729 ff.; G. F. Hill, *British Museum Catalogue of Coins: Lycaonia, Isauria and Cilicia*, lxxvi ff., 162 ff.

M. N. TOD

**TARTAK**, tār'tak (תַּרְתָּק, *tartāk*): In 2 K 17 31 mentioned as the name of an idol of the Avvites, one of the peoples sent by Shalmaneser to the cities of Samaria. It is otherwise unknown.

**TARTAN**, tār'tan (תַּרְתָּן, *tartān*): For a long time the word was interpreted as a proper name, but the Assyrian inscriptions have shown it to be the title of a high official. From the eponym lists it would seem that it was the title of the highest official next to the king, which in a military empire like Assyria would be the "commander-in-chief." The Assyrian form of the name is *tartanu* or *turtanu*. In both OT passages the reference is to a military officer. In Isa 20 1 it is used of the officer sent by Sargon, king of Assyria, against Ashdod; according to 2 K 18 17, Sennacherib sent Tartan and Rabsaris (q.v.) and Rabshakeh (q.v.) with a great host against Jerus. The names of the two officials are not known.

F. C. EISELEN

**TASKMASTER**, task'mas-tēr (שַׂר מַסָּ, *sar mas*, "chief of the burden" or "levy" [Ex 1 11]; נֹגְהֵס, *nōghēs*, "distress," "driver," "oppressor," "raiser of taxes," "taskmaster" [Ex 3 7; 5 6.10.13.14]): Officials of this class seem to have been officially

appointed by Pharaoh for the purpose of oppressing the Israelites and subduing their spirits, lest they seek complete independence or organize a rebellion against the government (Ex 1 11). The condition of the Israelites at this time became one of complete vassalage or slavery, probably owing to the fact that the Hyksos were driven out and a new dynasty was established, which knew nothing of Joseph and his people.

FRANK E. HIRSCH

**TASSEL**, tas'l (תַּצִּיחַ, *ṭāṣīḥ*): This word occurs only in Nu 15 38 (RVm), which reads "tassels in the corners" for "fringes in the borders of their garments" (AV).

It is probable that the dress of the Palestinian peasant has undergone little change in the centuries since the occupation of the land by the Hebrews. His outer garment, worn for protection against cold and rain, is the *simlāh* of Ex 22 26, now known as *'abāyah* by the Arabs. It is a square cloak, with unsewn spaces for armholes, and is composed of either three or four widths of woven stuff. The outer strips of the stuff, folded back and sewn at the upper edges, form shoulder-straps. It was to such a garment as this that the injunctions of Nu 15 37-41 and of Dt 22 12 applied. See FRINGES.

W. SEAW CALDECOTT

**TASTE**, tāst (Heb טַעַם, *ṭā'am*, "the sense of taste," "perception," from טָעַם, *ṭā'am*, "to taste," "to perceive"; Aram. טַעַם, *ṭā'em*, "flavor," "taste" [of a thing]; Heb הֶחֱךָ, *hēkhk*, "palate," "roof of the mouth" = "taste"; γεύομαι, *geiōmai*; noun γεύσις, *geúsīs*; in 2 Macc 7 1 the vb. is ἐφάπτομαι, *epháptomai*):

(1) **Literal**: (a) Gustation, to try by the tongue: "The taste [*ṭā'am*] of it [manna] was like wafers made with honey" (Ex 16 31); "Doth not the ear try words, even as the palate [*hēkhk*] tasteth [*ṭā'am*] its food?" (Job 12 11); "Belshazzar, while he tasted [lit. "at the taste of," *ṭā'em*] the wine, commanded to bring the golden and silver vessels which Nebuchadnezzar his father had taken out of the temple which was in Jerus; that the king and his lords, his wives and his concubines, might drink therefrom" (Dnl 5 2). (b) "To sample," "to eat but a small morsel": "I did certainly taste [*ṭā'am*] a little honey with the end of the rod that was in my hand; and, lo, I must die" (1 S 14 43).

(2) **Figurative**: "To experience," "to perceive": "Oh taste and see that Jeh is good" (Ps 34 8; cf 1 Pet 2 3); "How sweet are thy words unto my taste!" (m "palate," *hēkhk*) (Ps 119 103); "That by the grace of God he should taste of death for every man" (He 2 9); "For as touching those who were once enlightened and tasted of the heavenly gift, and were made partakers of the Holy Spirit, and tasted the good word of God, and the powers of the age to come . . ." (6 4.5).

H. L. E. LUERING

**TATTENAI**, tat'e-nī (תַּתַּנַּי, *tatt'nay*, various forms in LXX; AV *Tatnai*, *tat'ni*, *tat'nā-i*): A Pers governor, who was the successor of Rehum in Samaria and some other provinces belonging to Judah, bordering on Samaria. He governed the provinces during the reign of Darius Hystaspis and Zerubbabel (Ezr 5 3.6; 6 6.13). He was friendly to the Jews, and when he heard adverse reports from Jerus he suspended judgment till he had investigated the matter on the ground, and then reported to the Pers government in a very moderate manner. In 1 Esd 6 3.7.27; 7 1 he is called "Sisinnēs."

S. L. UMBACH

**TATTLER**, tat'lēr: Only in 1 Tim 5 13 for φλύαρος, *phlyáaros*. A "silly talker," rather than a "revealer of secrets," is meant.

TĀV, tāv. See TAW.

**TAVERNS, tav'érnz, THREE:**

Three Taverns (Lat *Tres Tabernae*, Gr transliterates *tréis tabérnai*; Cicero *Ad Att.* i.13; ii.12, 13) was a station on the Appian Road at the 33d milestone (30½ Eng. miles from Rome), according to the Itineraries of the Rom Empire (*Itin. Ant.* vii; *Tab. Peut.*; *Geogr. Rav.* iv.34), a converging point of traffic at the crossing of a road from Antium to Norba. Tripontium, 6 miles down the Appian Road in the direction of Appii Forum, was reckoned as the point where the highway entered the region of the Pontine marshes, the most notable natural feature of this part of Italy.

Parties of the Christian brethren in Rome went out to greet the apostle Paul when news was brought that he had arrived at Puteoli, one group proceeding as far as Appii Forum, while another awaited his coming at Three Taverns (Acts 28 15).  
GEORGE H. ALLEN

**TĀW, tāu** (תָּ, t, תּ, תּ): The 22d letter of the Heb alphabet; transliterated in this Encyclopaedia with the *dāḡhesh* as *t*, and as *th* without. It came also to be used for the number 400. For name, etc, see ALPHABET; see also FOREHEAD; MARK.

**TAX, taks, TAXING, taks'ing:**

**I. INTRODUCTION**

1. General Considerations
2. Limits of the Discussion

**II. TAXES IN ISRAEL UNDER SELF-GOVERNMENT**

1. In the Earliest Period
2. Under the Theocracy; in the Period of the Judges
3. Under the Kings

**III. TAXES IN ISRAEL UNDER CONQUERORS**

1. Under the Assyrians and Babylonians
2. Under the Persians
3. Under the Ptolemies and Seleucid Kings
4. Under the Romans

**I. Introduction.**—Taxation, in the sense of regular, graduated imposts levied by authority upon wealth, whether in the form of flocks and herds, tilled lands or accumulated treasure, is a comparatively late product of social evolution. The beginnings of this trouble-breeding institution are, of course, very ancient. If in the beginning all wealth was common wealth, all property vested in the family or tribe, making any kind of levies unnecessary, with the rise of individualism, the pro-rata setting aside, for common uses, of certain possessions held as private property by individuals, which is the essence of taxation, is inevitable. With the advent of more advanced civilization, by which is meant fixed residence, systematic use and cultivation of defined and limited territory, established political organization centering in rulers of one kind or another, regular taxation must necessarily have begun. Throughout history the burden of taxation has kept pace with the elaboration of the machinery of government; kings, courts, ceremonies, legislative and judicial administration, wars, diplomacy—all these institutions spell expense and, consequently, taxation. In a very real sense, the history of taxation is the history of civilization.

In following the history of taxation in the Bible, two lines of development are to be noted: Israel's internal history when left to herself,

**2. Limits of the Discussion** and her experiences as tributary to successive conquerors. These two lines of experience form the main divisions of this article. We shall confine ourselves so far as possible to the civil aspects of the subject, leaving for others those interesting problems of taxation connected with the origin and

development of the priestly legislation. See THESE, etc.

**II. Taxes in Israel under Self-Government.**—In the first glimpses of the ancestors of the Heb people given us in the Bible, no such institution as taxation appears.

Like all primitive communities, the nomadic Hebrews had no regular system of taxation nor use for any. Voluntary presents were given by the less to the more powerful in return for protection or other advantages. These are really ominous words, for even as late as the United Kingdom, when, of a certainty, the voluntary element had long since gone out,

the royal income was spoken of, with perhaps unconscious irony, as "presents" (1 S 10 27; 1 K 4 21; 10 25). One great taproot of the whole after-development of systematic taxation is to be found in this primitive custom of giving presents (Gen 32 13-21; 33 10; 43 11). The transition is so fatally easy from presents voluntarily given to those which are expected and finally to those which are demanded (2 K 16 8; cf 17 4, where AV has "presents").

The first evidence of what corresponds to compulsory taxation discoverable in the Bible is in connection with the conquered Canaanites who were compelled to serve under tribute, that is, to render forced labor (Josh 16 10; 17 13; Jgs 1 28-35). In the early custom of making presents to the powerful and in the exactions laid upon conquered peoples, with the necessary public expense of community life as the natural basis, we have the main sources of what grew to be institutional taxation.

The only fixed impost under the theocracy which has a semi-civil character was the so-called "atonement money" (Ex 30 11-16), really a

**2. Under the Theocracy and Judges** poll-tax amounting to a half-shekel for each enrolled male member of the community above 20 years of age. The proceeds of this tax were to be used for the service of the Tent of Meeting (see TABERNACLE). It seems to have been levied by the authorities and accepted by the people whenever faithfulness to the ordinances of Jeh was the order of the day (2 Ch 24 4-14; Neh 10 32; note here the emphasis laid upon the offering as voluntary, and the variation in amount from one-half to one-third shekel). In later times this tax was devoted to the service of the temple, and was paid by Jews at a distance during the Dispersion. Jos speaks of the large amounts accruing to the temple-treasury from this source (*Ant.* XIV, vii, 2). It was still collected as the distinctive temple-tax levied upon the citizen as such (Mt 17 24). It is interesting to note that Jesus paid it under protest and with one of the most distinctive of His miracles, on the ground of His being the founder and head of a new temple, and hence not subject to the impost which was the badge of citizenship in the old order.

The period of the Judges was too disorganized and chaotic to exhibit many of the characteristics of a settled mode of procedure. As far as we know the only source of public moneys was the giving of presents. If the action of Gideon (Jgs 8 24) is to be taken as indicating the ordinary policy of the period, the judges received nothing more than a share of the spoil taken in battle. The account emphasizes, evidently with purpose, the fact that Gideon proffers a request (ver 24), and that the people respond freely and gladly.

As was to be expected, taxation assumes far greater prominence the moment we cross the threshold of the kingdom. 1 S 8 10-18 is

**3. Under the Kings** equally significant for our purpose whether it was, as appears on the face of the narrative, the actual words of warning uttered by Samuel in view of the well-known attitude of kings in general, or a later recension from the viewpoint of experience. In either case, the passage gives us a fairly exhaustive list of royal prerogatives. Aside from various forms

of public and private service, the king would *take* (note the word) the best of the vineyards, etc. together with a tenth of the seed and of the flocks. The underlying principle, suggested by Samuel's summary and fully exemplified in the actions of Israel's kings, is that the king would take what he needed for his public and private needs from the strength and substance of his people. Constitutional laws regulating the expenditure of public funds and the amount of exactions from the people in taxation seem never to have been contemplated in these early monarchies. The king took what he could get; the people gave what they could not hold back. The long battle for constitutional rights has centered from the beginning about the matter of taxation.

In 1 S 10 27 (cf 2 Ch 17 5) the case cited of worthless fellows who brought Saul no present clearly shows that fealty to the new king was expressed in the giving of presents. The refusal to make these so-called presents was an act of constructive treason, so interpreted by the writer, who mentions Saul's silence in the premises as something notable. It is evident that the word "present" has become euphemistic. In 1 S 17 25 exemption from taxation is specifically mentioned, together with wealth and marriage into the royal family, as one element in the reward to be obtained for ridding Israel of the menace of Goliath.

In David's time an unbroken series of victories in war so enriched the public treasury (see 2 S 8 2.7.8) that we hear little of complaints of excessive taxation. If David's census was for fiscal purposes (24 2), we can understand why he was so severely dealt with for it, but the matter is still obscure. David's habit of dedicating spoil to Jeh (8 10-12) kept the sacred treasury well supplied. Solomon undoubtedly inherited David's scale of public expense (1 Ch 27 25-31) and added to it through his well-developed love of luxury and power. At the same time the cessation of war made the development of internal resources for carrying on his ambitious schemes imperative. The boundaries of his kingdom are specified (1 K 4 21 (Heb 5 1) together with the amount of his income (1 K 10 14.28; cf 2 K 3 4). It is also stated that other kingdoms paid tribute to him. His system of fiscal administration was very thoroughly organized. He put the whole country under twelve officers (to specify one feature) whose business it was to provide, by months, provisions for the court (1 K 4 7-19). Under Solomon also, for the first time, so far as we know, Israelites were compelled to render forced labor (1 K 5 13-17). By the end of his reign the burden of taxation had become so severe that in the public address made to Rehoboam the people demanded a lightening of the "grievous service" of Solomon as the condition of their fealty to his successor. Rehoboam's foolish answer of defiance precipitated the separation of the tribes which proved in the end so disastrous. During the period of prophetic activity which follows, one recurring specification in the denunciations uttered by the prophets against the kings was the excessive burden of taxation imposed upon the people. Amos speaks of "exactions of wheat taken from the poor" (5 11; cf 2 6-8). In 7 1 he incidentally refers to a custom which has grown up of rendering to the king the first mowings of grass. Isaiah speaks of eating up the vineyards and taking the spoil of the poor (3 14). Micah, with even greater severity, denounces rulers "who eat the flesh of my people" (3 1-4). These citations are sufficient to show that all through the later monarchy the Israelites suffered more or less from official rapacity and injustice.

**III. Israel under Conquerors.**—During the reign of Menahem, who succeeded Jeroboam II as king of Israel, the Assyrian invasion under

**1. Assyria** Tiglath-pileser III (Bib. "Pul," 2 K and 15 19) began. The one act of Menahem (aside from his general sinfulness) which is specified in 2 K 15 17-22, the remainder of his unedifying career being left to the Chronicles of the kings of Israel, is that he bought off the Assyrian conqueror by a tribute of a thousand talents which he obtained by mulcting men of wealth in his kingdom to the extent of fifty talents each. A little later, Ahaz of Judah sent a present to the same ruler. He took the novel method of robbing the temple-treasury and adding the sum thus gained to the accumulations at hand in the royal treasury. Both these kings were somewhat original in their methods. Hoshea of Israel, a contemporary of Ahaz, was reduced to tribute;

later, upon his neglect to pay, he was put in prison (2 K 17 4). A little later still, Jehoahaz, the son of Josiah, was deposed by Pharaoh-necho, who placed a tribute upon the land of a hundred talents of silver and one of gold (2 K 23 31-33). Jehoia-kim, the puppet king, raised this tribute by a special tax upon the people (vs 34.35). This latter passage is especially interesting because it seems to indicate (vs 35 f) a graduated system of taxation supposedly honored more often in the breach than in the observance. This same unfortunate Jehoia-kim came under the heavy hand of Nebuchadnezzar (2 K 24 1-7). This latter ruler seems not to have levied a special tribute, at least it is not mentioned; but reimbursed himself for the expenses of conquest by carrying away to Babylon the vessels of the temple (2 Ch 36 7).

In Ezr 4 13, a part of a letter addressed to Artaxerxes by officials "west of the river" (see whole passage vs 7-24) who were hostile to the Jews, it is charged that in the event of rebuilding the city the inhabitants would not pay "tribute, custom, or toll." These three words, which are evidently combined in a formula and indicate three distinct classes of taxes, are interesting as being characteristic of the Pers period.

The three words are: (1) מְדָה, *middāh* = "tribute" (Ezr 4 13.20; cf Neh 5 4, where the expression is "king's tribute"); (2) בְּרִי, *b'rī* = according to Gesenius s.v.: "tax on articles consumed" or "excise" (*HDB* "impost") (Ezr 4 13.20; 7 24); (3) הַלָּאָה, *hālākāh* = "road-toll" or "custom tax" (Ezr 4 13.20; 7 24). These Assyrian words are to be contrasted with the words used elsewhere: (1) מַס, *maṣ* = "forced labor" (1 K 5 13 [Heb 5 27]; cf ut sup. Josh 16 10; 17 13; Jgs 1 28. 30.33.35; Dt 20 11; Est 10 1); (2) מַשָּׂא, *massā* = "burden" (2 Ch 17 11); (3) מִקְשָׁה, *mekheṣ* = "measure," used of tribute exacted for Jeh, taken from people, cattle, and spoil, etc (Nu 31 25-31). From this enumeration and comparison it will be seen that the Heb had no general word corresponding to the Eng. word "tax."

To return to the situation in the Pers period, it is evident that the Pers rulers exacted practically the same classified tributes, direct and indirect, that are found elsewhere. It is recorded that Artaxerxes, in response to the letter of his officers in Pal (Ezr 4 21), stopped the work of the rebuilding of Jerus in anticipation of the refusal of the Jewish leaders to pay taxes. The work was resumed in the 2d year of Darius under the protection of a royal decree which gave to the Jewish authorities a sufficient amount from the "tribute beyond the river" to finish without delay.

Artaxerxes, in addition to his generous gifts, exempted the priests and temple-servants from all taxation (Ezr 7 24). In the days of Nehemiah a serious condition arose. The king's tribute was so heavy that the Jewish common people were compelled to borrow money upon mortgages, and in so doing fell into the hands of usurers of their own people, by whom they were so impoverished as to be compelled to sell their sons and daughters into slavery (Neh 5 1-13). In addition to the royal tribute, they were forced to support the governors who were entitled to bread, wine and forty shekels of silver annually (vs 14.15). In the prayer offered on the fast day (Neh 9) it was asserted that their burdens of taxation were so heavy that they were servants in their own land (vs 36.37).

The Ptolemies, who practically controlled Pal from 301 to 218 BC, do not appear to have been excessive in their demands for tribute (twenty talents for Jews [*Ant*, XII, iv, 1] seems no great amount), but the custom which they introduced, or at least established, of farming the taxes to the highest bidder, introduced a principle which pre-

veiled through all the subsequent history and was the cause of much popular suffering and discontent.

**3. Under the Ptolemies and Seleucid Kings**

The story of Joseph, the Jewish tax-collector (*Ant*, XII, iv, 1-5), who was for 23 years farmer-general of taxes for Pal under Ptolemy Euergetes, and the cause of "a long train of disasters," is peculiarly significant for the student of the NT.

The conquest of Pal by Antiochus the Great (202 BC) brought a certain amount of relief to the "storm-tossed" (Jos) Jews of Pal, as of old the buffer state between contending powers. According to Jos (*Ant*, XII, iii, 3), Antiochus gave the Jews generous gifts in money, remitted their taxes for three years, and permanently reduced them one-third (see Kent's discussion of the credibility of these statements, *Historical Series for Bible Students*, Bab, Pers, Gr Periods, 296).

That the Seleucid kings were particularly severe in their exactions is clearly shown in the letter of Demetrius to the Jews, whose favor he was seeking in rivalry with Alexander Balas of Smyrna, the pretender to the Seleucid throne (see 1 Macc 10 26-30; 11 34.35; 13 39; cf 11 28).

In this quoted letter Demetrius promises the following exemptions: from (1) "tributes" (*φόροι, phōroi* = "poll-taxes"); (2) tax on salt; (3) crown taxes (*στέφανοι, stēphanōi* = "crowns of gold" or their equivalents); (4) the tribute of one-third of the seed; (5) another of one-half of the fruit of the trees (10 29.30). This seems almost incredibly severe, but evidence is not lacking of its probability (Lange's *Comm. Apoc*, ed 1901, 525). With Seleucus IV (187-176 BC) the Jews felt for the first time, indirectly but powerfully, the pressure of Rome. This disreputable ruler had to pay tribute to Rome as well as to find means whereby to gratify his own passion for luxury, and was correspondingly rapacious in the treatment of his subjects (2 Macc 3).

During the early part of the Herodian epoch, taxes were paid to the king and collected by officers appointed by him. This method

**4. Under the Romans**

which worked fairly well, at least under Herod the Great, had passed away before any books of the NT were written. After the deposition of Archelaus (6 AD), at the request of the Jews themselves, Judaea was incorporated into the Rom empire and put under procurators who were in charge of all financial administration, although the tetrarchs still collected the internal taxes. This fact conditions all that is to be said about "tribute" and "publicans" in connection with the NT. It is to be noted first of all (a fact that is often overlooked by the student) that in the imperial era the direct taxes were not farmed out, but collected by regular imperial officers in the regular routine of official duty. The customs or tolls levied upon exports and imports, and upon goods in the hands of merchants passing through the country, were sold to the highest bidders, who were called "publicans."

With this distinction clearly in mind we may dismiss the subject of general taxation with the following remarks: First, that the taxes in Judaea went to the imperial treasury (Mt 22 17; Mk 12 14; Lk 20 22); second, that these taxes were very heavy. These two facts explain why the question of paying tribute to Caesar, which Our Lord was obliged to meet, was so burning an issue. It touched at once religious and financial interest—a powerful combination. In 7 AD, immediately after the appointment of Coponius as procurator, Quirinius (see Quirinius, *NT Chronology*, etc) was sent to Judaea to take a census (*ἀπογραφή, apographē*) for the purpose of a poll-tax (*κηνσος, kēnsos, φόρος, phōros*, or *ἐπικεφάλαιον, epikēphalaion* [Mt 22 17; Mk 12 13.14; Lk 20 20 ff]). This census was the occasion for the bloody uprising of Judas of Gamala (or Galilee) (Acts 5 37; cf *Ant*, XVIII, i, 1, 6). As a matter of historical fact this same census was the occasion of the final destruction of the Jewish commonwealth, for the fierce antagonism to Rome which was aroused at that time never died out until it was extinguished in blood, 70 AD.

We are now free to discuss those matters which

center in a general way about the term "publican." According to Stapfer (*PTC*, 215) this term (*τελώνης, telōnēs*) is commonly used to cover several grades of minor officials engaged in the customs service. The word was extended in meaning from the *publicanus*, properly so called, the farmer-general of a province, to his subordinate local officials. The publicans of the NT "examined the goods and collected tolls on roads and bridges" (Stapfer, *op. cit.*, 216; cf Mt 9 9). These tolls (Lat *portoria*; Gr *τέλη, télē*) were collected in Pal at Caesarea, Capernaum and Jericho (Jos, *BJ*, II, xiv, 4). Those collected at Capernaum went into the treasury of Herod Antipas. At Jericho there was a chief publican (*ἀρχιτελώνης, architelōnēs*), but most of the publicans mentioned in the NT were probably subordinate to men higher in authority.

Sufficient cause for the unpopularity of publicans in NT times is not far to seek. Hatred of paying duties seems to be ingrained in human nature. Customs officials are always unpopular. The method is necessarily inquisitorial. The man who opens one's boxes and bundles to appraise the value of what one has, is at best a tolerated evil. In Judaea, under the Rom system, all circumstances combined to make the publican the object of bitter hatred. He represented and exercised in immediate contact, at a sore spot with individuals, the hated power of Rome. The tax itself was looked upon as an inherent religious wrong, as well as civil imposition, and by many the payment of it was considered a sinful act of disloyalty to God. The tax-gatherer, if a Jew, was a renegade in the eyes of his patriotic fellows. He paid a fixed sum for the taxes, and received for himself what he could over and above that amount. The ancient and widespread curse of arbitrariness was in the system. The tariff rates were vague and indefinite (see Schürer, *HJP*, I, ii, 67 f.). The collector was thus always under the suspicion of being an extortioner and probably was in most instances. The name was apt to realize itself. The usual combination in a publican of petty tyrant, renegade and extortioner, made by circumstances almost inevitable, was not conducive to popularity. In the score of instances in the NT where publicans are mentioned, their common status, their place in the thought and action of Jesus, their new hope in the gospel are clearly set forth. The instances in which Our Lord speaks of them are especially illuminating: (1) He uses them on the basis of the popular estimate which the disciples undoubtedly shared, to point in genial irony a reproach addressed to His hearers for their low standard of love and forgiveness (Mt 5 46.47). (2) He uses the term in the current combination in giving directions about excommunicating a persistently unrepentant member of the church (Mt 18 17). (3) He uses the term in the popular sense in describing the current condemnation of His attitude of social fellowship with them, and constructively accepts the title of "friend of publicans and sinners" (Mt 11 19; Lk 7 34). (4) Most significant of all, Jesus uses the publican, as He did the Samaritan, in a parable in which the despised outcast shows to advantage in an attitude acceptable to God (Lk 18 9 ff).

This parable is reinforced by the statement, made more than once by Our Lord, that the readiness to repent shown by the publicans and other outcasts usually found with them was more promising of salvation than the spiritual pride shown by some who were satisfied with themselves (Lk 3 12; cf 7 29; Mt 21 31.32; Lk 15 1). The choice of Levi as a disciple (Mt 10 3, etc) and the conversion of Zacchaeus (Lk 19 8 f.), of whom Jesus speaks so beautifully as a son of Abraham (ver 9), justified the characteristic attitude which Our Lord adopted toward this despised class, about equally guilty and unfortunate. He did not condone their faults or crimes; neither did He accept the popular verdict that pronounced them unfit for companionship with the good



and without hope in the world. According to the teaching and accordant action of Jesus, no man or woman is without hope until the messenger of hope has been definitely rejected.

It is fitting, if somewhat dramatic, that a study of taxation—that historic root of bitterness periodically springing up through the ages—should end in contemplation of Him who spoke to an outcast and guilty tax-collector (Lk 19 10) the wonderful words: "The Son of man came to seek and to save that which was lost." LOUIS MATTHEWS SWEET

**TEACH**, *tēch*, **TEACHER**, *tēch'ēr*, **TEACHING**, *tēch'ing*:

- |                     |                           |                           |
|---------------------|---------------------------|---------------------------|
| <b>I. OT TERMS</b>  |                           | 5. Exposition             |
| 1. Discipline       |                           | 6. Authority              |
| 2. Law              |                           | 7. Care                   |
| 3. Discernment      |                           | 8. Supervision            |
| 4. Wlsdom           | <b>III. OT HISTORY</b>    | 1. In the Home            |
| 5. Knowledge        |                           | 2. In Public              |
| 6. Illumination     | <b>IV. EXTRA-BIBLICAL</b> | <b>TEACHING</b>           |
| 7. Vision           |                           | <b>V. NT HISTORY</b>      |
| 8. Inspiration      |                           | 1. Christ's Life          |
| 9. Nourishment      |                           | 2. Apostolic Labors       |
| <b>II. NT TERMS</b> |                           | 3. General Considerations |
| 1. Instruction      |                           |                           |
| 2. Acquisitlon      |                           |                           |
| 3. Presentation     |                           |                           |
| 4. Elucidation      |                           |                           |

A rich variety of words is employed in the Bible to describe the teaching process. The terms do not so much indicate an office and an official as a function and a service, although both ideas are often expressed or implied.

**I. OT Terms.**—**לָמַד**, *lāmādh*, "to beat": A very common word for "to teach"; it may have meant "to beat with a rod," "to chastise," and may have originally referred to the striking and goading of beasts by which they were curbed and trained.

### 1. Discipline

By a noble evolution the term came to describe the process of disciplining and training men in war, religion and life (Isa 2 3; Hos 10 11; Mic 4 2). As teaching is both a condition and an accompaniment of disciplining, the word often means simply "to teach," "to inform" (2 Ch 17 7; Ps 71 17; Prov 5 13). The glory of teaching was its harmony with the will of God, its source in God's authority, and its purpose to secure spiritual obedience (Dt 4 5,14; 31 12,13).

**רָאָה**, *yārāh*, "to cast": The teaching idea from which the law was derived is expressed by a vb. which means "to throw," "to cast as an arrow or lot." It is also used of thrusting the hand forth to point out or show clearly (Gen 46 28; Ex 15 25). The original idea is easily changed into an educational conception, since the teacher puts forth new ideas and facts as a sower casts seed into the ground. But the process of teaching was not considered external and mechanical but internal and vital (Ex 35 34,35; 2 Ch 6 27). The nominal form is the usual word for law, human and Divine, general and specific (Dt 4 8; Ps 19 8; Prov 1 8). The following are suggestive phrases: "the book of the law" (Dt 28 61; 2 K 22 8); "the book of the law of Moses" (Josh 8 31; 2 K 14 6); "the book of the law of God" (Josh 24 26); "the book of the law of Jeh" (2 Ch 17 9). Thus even in the days of Joshua there was in the possession of the religious teachers a book of the Law of the Lord as given by Moses. This recorded revelation and legislation continued to be the Divine norm and ultimate authority for priest, king and people (2 Ch 23 11; Neh 8 1-3).

### 2. Law

**בִּיָּר**, *bīyār*, "to separate": The word meaning "to separate," "to distinguish," is often used in a causative sense to signify "to teach." The idea of teaching was not an aggregation of facts bodily transferred like merchandise. Real learning

followed genuine teaching. This word suggests a sound psychological basis for a good pedagogy.

The function of teaching might be exercised with reference to the solution of difficult problems, the interpretation of God's will, or the manner of a godly life (Dnl 8 16,26; Neh 8 7-9; Ps 119 34).

**שָׁחַל**, *sākhāl*, "to be wise": The vb. from which the various nominal forms for "wisdom" are derived means "to look at," "to behold," "to view," and in the causative stem describes the process by which one is enabled to see for himself what had never before entered his physical or intellectual field of consciousness. The noun indicates a wise person or sage whose mission is to instruct others in the ways of the Lord (Prov 16 23; 21 11; and often in the Wisdom literature). In Dnl 12 3 we read: "They that are wise [m "the teachers"] shall shine as the brightness of the firmament."

**יָדָה**, *yādāh*, "to see" (cf *ōdā*, *ōdā*): This vb. lit. means "to see" and consequently "to perceive," "to know," "to come to know," and "cause to know or teach." It describes the act of knowing as both progressive and completed. The causative conception signifies achievement in the sphere of instruction. It is used of the interpretation and application by Moses of the principles of the law of God (Ex 18 16,20), of the elucidation of life's problems by the sages (Prov 9 9; 22 19), and of constant Providential guidance in the way of life (Ps 16 11).

**זָהַר**, *zāhar*, "to shine": This verbal root signifies "to shine," and when applied to the intellectual sphere indicates the function of teaching to be one of illumination. Ignorance is darkness, knowledge is light. Moses was to teach the people statutes and laws, or to enlighten them on the principles and precepts of God's revelation (Ex 18 20). The service rendered by the teachers—priests, Levites and fathers—sent forth by Jehoshaphat, was one of illumination in the twofold sense of instruction and admonition (2 Ch 19 8-10).

**רָאָה**, *rā'āh*, "to see": The literal meaning of this vb. is "to see," and the nominal form is the ancient name for prophet or authoritative teacher who was expected to have a clear vision of spiritual realities, the will of God, the need of man and the way of life (1 S 9 9; 1 Ch 9 22; 2 Ch 16 7 f; Isa 30 10).

**נָבָה**, *nābhā*, "to boil up": The most significant word for "prophet" is derived from the vb. which means "to boil up or forth like a fountain," and consequently to pour forth words under the impelling power of the Spirit of God. The Hebrews used the passive forms of the vb. because they considered the thoughts and words of the prophets due not to personal ability but to Divine influence. The utterances of the prophets were characterized by instruction, admonition, persuasion and prediction (Dt 18 15-22; Ezk 33 1-20).

**רָעָה**, *rā'āh*, "to feed a flock": The name "shepherd," so precious in both the OT and the NT, comes from a vb. meaning "to feed," hence to protect and care for out of a sense of devotion, ownership and responsibility. It is employed with reference to civil rulers in their positions of trust (2 S 5 2; Jer 23 2); with reference to teachers of virtue and wisdom (Prov 10 21; Eccl 12 11); and preëminently with reference to God as the great Shepherd of His chosen people (Ps 23 1;

Hos 4 16). Ezk 34 presents an arraignment of the unfaithful shepherds or civil rulers; Ps 23 reveals Jeh as the Shepherd of true believers, and Jn 10 shows how religious teachers are shepherds under Jesus the Good Shepherd.

**II. NT Terms.**—Further light is thrown upon religious teaching in Bible times by a brief view of the leading educational terms found in the NT.

*διδάσκω, didáskō*, "to teach": The usual word for "teach" in the NT signifies either to hold a discourse with others in order to instruct

**1. Instruc-** them, or to deliver a didactic dis-  
**tion** course where there may not be direct personal and verbal participation.

In the former sense it describes the interlocutory method, the interplay of the ideas and words between pupils and teachers, and in the latter use it refers to the more formal monologues designed esp. to give information (Mt 4 23; chs 5-7; 13 36 f; Jn 6 59; 1 Cor 4 17; 1 Tim 2 12). A teacher is one who performs the function or fills the office of instruction. Ability and fitness for the work are required (Rom 2 20; He 5 12). The title refers to Jewish teachers (Jn 1 38), to John the Baptist (Lk 3 12), to Jesus (Jn 3 2; 8 4, and often), to Paul (1 Tim 2 7; 2 Tim 1 11), and to instructors in the early church (Acts 13 1; Rom 12 7; 1 Cor 12 28). Teaching, like preaching, was an integral part of the work of an apostle (Mt 28 19; Mk 16 15; Eph 4 1).

*μανθάνω, manthánō*, "to learn": The central thought of teaching is causing one to learn. Teaching and learning are not scholastic

**2. Acqui-** but dynamic, and imply personal  
**sition** relationship and activity in the acquisition of knowledge (Mt 11 29;

28 19; Acts 14 21). There were three concentric circles of disciples in the time of Our Lord: learners, pupils, superficial followers, the multitude (Jn 6 66); the body of believers who accepted Jesus as their Master (Mt 10 42); and the Twelve Disciples whom Jesus also called apostles (Mt 10 2).

*παρὰθῆμι, paratithēmi*, "to place beside": The presentative idea involved in the teaching process is intimately associated with the principle of adaptation. When it is stated

**3. Presen-** that Christ put forth parables unto the  
**tation** people, the sacred writer employs the

figure of placing alongside of, or near one, hence before him in an accessible position. The food or teaching should be sound, or hygienic, and adapted to the capacity and development of the recipient (Mt 13 24; Mk 8 6; Acts 16 34; 1 Cor 10 27; 2 Tim 4 3; He 5 12-14).

*διερμηνεύω, diermeneuō*, "to interpret": In the walk to Emmaus, Christ explained to the perplexed disciples the OT Scriptures in reference to Himself. The work of interpreter is to make truth clear

**4. Eluci-** and to effect the edification of the  
**dation** hearer (Lk 24 27; 1 Cor 12 30; 14 5.13.27).

*ἐκτίθῆμι, ektithēmi*, "to place out": The vb. lit. means "to set or place out," and signifies to bring out the latent and secret ideas

**5. Expo-** of a literary passage or a system of  
**sition** thought and life. Thus Peter interpreted his vision, Aquila and Priscilla

unfolded truth to Apollos, and Paul expounded the gospel in Rome (Acts 11 4; 18 26; 28 23). True teaching is an educational exposition.

*προφήτης, prophētēs*, "one who speaks for": A prophet was a man who spoke forth a message from God to the people. He might deal

**6. Author-** with past failures and achievements,  
**ity** present privileges and responsibilities, or future doom and glory. He received

his message and authority from God (Dt 18 15-22;

Isa 6). The word refers to OT teachers (Mt 5 12), to John the Baptist (Mt 21 26), to Jesus the Messiah (Acts 3 25), and to special speakers in the Apostolic age (Mt 10 41; Acts 13 1; 1 Cor 14 29.37).

*ποιμήν, poimēn*, "a shepherd": The word for "shepherd" signifies one who tends a flock, and by analogy a person who gives mental and

**7. Care** spiritual nourishment, and guards and supports those under his care (Mt 9

36; Jn 10 2.16; 1 Pet 2 25; Eph 4 11). Love is a fundamental prerequisite to the exercise of the shepherding function (Jn 21 15-18). The duties are to be discharged with great diligence and in humble recognition of the gifts and appointment of the Holy Spirit (Acts 20 28).

*ἐπίσκοπος, episkopos*, "an overseer": The bishop or overseer was to feed and protect the blood-

**8. Super-** bought church of God (Acts 20 28).  
**vision** Among the various qualifications of the religious overseers was an aptitude for teaching (1 Tim 3 2; Tit 1 9). The

Lord is preëminently shepherd and bishop (1 Pet 2 25).

**III. OT History.**—In the Jewish home the teaching of the law of the Lord was primarily incumbent upon the parents. The teaching was

**1. In the** to be diligent, the conversation reli-  
**Home** gious, and the atmosphere wholesome (Dt 6 7-9).

Provision was also made for public instruction in the law of God (Dt 31 12.13). This is a compact summary of early Heb teaching in

**2. In Public** regard to the extent of patronage, the  
**sition** substance of instruction, and the purpose of the process. Samuel the judge and prophet recognized that his duty was fundamentally

to pray to God for his people and to teach the nation "the good and the right way" (1 S 12 23). The glory and prosperity of Judah under Jehoshaphat were due in large measure to the emphasis he laid upon religious instruction as the basis of national character and stability. His peripatetic Bible school faculty consisted of five princes, nine Levites and two priests who effected a moral and religious transformation, for "they taught in Judah, having the book of the law of Jeh with them" (2 Ch 17 7-9). The most striking illustration we have of public religious instruction in the OT is found in Neh 8. Ezra the priest and scribe was superintendent, and had an ample corps of teachers to instruct the multitude of men, women and children eager to hear. Prayer created a devotional atmosphere. The reading was distinct, the interpretation correct and intelligible. There was real teaching because the people were made to understand and obey the law. In Neh 9 and 10 we have recorded the spiritual, ceremonial, social and civic effects of ancient religious instruction.

**IV. Extra-Biblical History.**—The captivity gave a mighty impulse to teaching. In far-away Babylon the Jews, deprived of the privilege and inspiration of the temple, established the synagogue as an institutional center of worship and instruction. During the latter part of the inter-Bib. period, religious teaching was carried on in the synagogue and attendance was compulsory, education in the Law being considered the fundamental element of national security (Deutsch, *Literary Remains*, 23; Edersheim, *Life and Times of Jesus the Messiah*, I, 230). The Bible text alone was taught those from 5 to 10 years of age, the first lessons being taken from Lev (Taylor, *Sayings of the Jewish Fathers*, 111). From 10 to 15 years of age the pupil was taught the substance of the Mish or unwritten tradition, and accorded the privilege of entering into the discussions of the Mish, which constitute the Gemara (Edersheim, op. cit., I, 232). Selections of Scriptures like the *sh'ma'* (Dt 6 4-9) were made for study, and lesson helps were adapted to the capacity of the pupils (Ginsburg, art. "Education" in *Cyc. of Bib. Lit.*). The significance of the teaching idea among the Jews is indicated by numerous expressions for school (art. "Education," *Cyc. of Bib. Lit.*) and the prevalence of the synagogues, there

being perhaps 480 in Jerus in the time of Christ (*Hor. Heb.* 1, 78). The pupil was not expected to be a passive hearer but an active participant (*Ab.* vi.6; Taylor, *Sayings of the Jewish Fathers*, 115 f.). Great emphasis was laid upon audible repetition and exact memory, yet the teacher was culpable if the pupil failed to understand the prescribed lesson (*Hamburger, RE.* II, 672, 674). The pupil was regarded as the child of his teacher (*Sanhedrin* 19), which is a familiar idea in the NT. The faithful teacher was considered destined to occupy a high seat among the ancients (*Dnl* 12 3). The scribes were secretaries or copyists of the sacred Law, and would thus acquire at least an accurate verbal knowledge of its contents. Quite naturally they would become religious teachers (*Neh* 8 4). Hence also their prominence in the NT.

LITERATURE.—Art. "Torah," *Jew Enc* (cf arts. "Talmud" and "Education"); Trumbull, *Yale Lectures on the Sunday-School*, 3-40; *Hamburger, RE.*

**V. NT History.**—In the NT we find that Jesus is preëminently the teacher, though He was also preacher and healer (*Mt* 4 23). His **1. Christ's** Sermon on the Mount was matchless teaching. He opened His mouth and "taught" (*Mt* 5 2). The titles "teacher," "master," "rabbi" all indicate the most prominent function of His active ministry. Even at the age of 12 years He revealed His wisdom and affinity in the midst of the rabbis or Jewish teachers of the Law in the temple (*Lk* 2 41 f.). In the power of the Spirit He taught so that all recognized His authority (*Lk* 4 14.15; *Mt* 7 29). He explained to the disciples in private what He taught the people in public (*Mt* 13 36). His principles and methods of teaching constitute the standard by which all true pedagogy is measured, and the ideal toward which all subsequent teachers have toiled with only partial success (*Mt* 7 28.29; *Jn* 1 49; 3 2; 6 46). In the Commission as recorded in *Mt* 28 18.19.20 we have the work of Christianity presented in educational terms. We find the supreme authority (ver 18), the comprehensive content—the evangelistic, the ceremonial, the educational, the practical (vs 19 and 20a), and the inspiring promise (ver 20b).

The emphasis laid upon teaching in the Apostolic age is a natural consequence of the need of the people and the commands of Jesus. **2. Apostolic** The practice of the apostles is quite uniform. They preached or proclaimed, but they also expounded. In Jerus the converts continued in the apostles' teaching (*Acts* 2 42); and daily in the temple and in the homes of the people the teaching was correlated with preaching (*Acts* 5 42). In Antioch, the center of foreign missionary operations, Paul, Silas, Barnabas and many others taught the word of the Lord (*Acts* 15 35). In Thessalonica, Paul and Silas for three weeks reasoned with the people out of the Scriptures, opening up the sacred secrets and proving to all candid minds that Jesus was the Messiah (*Acts* 17 1-3). In Berea, instruction in the synagogue was followed by private study, and as a result many believed in the Lord (*Acts* 17 10-15). In Athens, Paul discussed and explained the things of the kingdom of God, both in the synagogue 3 t a week and in the market daily (*Acts* 17 16 f.). In Corinth, Paul having been denied the use of the synagogue taught the word of the Lord for a year and a half in the house of Justus, and thus laid the foundation for a great church (*Acts* 18 1-11). In Ephesus, Paul taught for 2 years in the school of Tyrannus, disputing and persuading the people concerning the kingdom of God (*Acts* 19 8-10). In Rome, Paul expounded the word, testified to its truth, and persuaded men to accept the gospel (*Acts* 28 23). His method of work in Rome under trying limitations is described as cordially receiving the people and preaching the kingdom of God, and "teaching the things concerning the Lord Jesus Christ" (*Acts* 28 30.31).

The office of teacher is fundamentally related to the creation of a missionary atmosphere (*Acts* 13 1). Religious teaching is necessary to the development of Christian character and the highest efficiency in service (*1 Cor* 12 4-11.28.29; *Eph* 4 11.12). The qualification of the pastor is vitally connected with the teaching function of the church. He is to hold the truth, or to be orthodox (*Tit* 1 9), to apply the truth, or to be practical (*Tit* 1 9), to study the truth, or to be informed (*1 Tim* 4 13.15), to teach the truth, or to be equipped or able and tactful (*2 Tim* 2 2; *1 Tim* 3 2), to live the truth, or to be faithful in all things (*2 Tim* 2 2; *1 Tim* 4 16). The teaching function of Christianity in the 2d cent. became strictly official, thereby losing much of its elasticity. A popular manual for the guidance of religious teachers was styled the "Teaching of the Twelve" (see *DIDACHE*). The writings of the Apostolic Fathers give valuable information in regard to the exercise of the gifts of teaching in the early centuries (*Did.*, xiii.2; xv.1, 2; *Barn* 18; *Ign. Eph* 31). See *CATECHIST*; *EDUCATION*; *SPIRITUAL GIFTS*. BYRON H. DEMENT

**TEAR BOTTLE.** See next article.

**TEARS,** tēz (תֵּירוֹת, *dīm'āh*; δάκρυα, *dákrua*): In the instances recorded in Scripture weeping is more frequently associated with mental distress than with physical pain. Eastern peoples show none of the restraint of emotion in lamentation which is characteristic of modern Occidentals, and there are many records of this manifestation of woe, even among men accustomed to hardships and warfare, such as David and his soldiers. The flow of tears is the evidence of sorrow in prospect of approaching death in *Ps* 39 12; *2 K* 20 5; *Isa* 38 5, and of the suffering consequent on oppression (*Ecl* 4 1), or defeat in battle (*Isa* 16 9), or hopeless remorse, as with Esau (*He* 12 17, probably referring to *Gen* 27 34). The Psalmist describes his condition of distress metaphorically as feeding on the bread of tears and having tears to drink (*Ps* 80 5; 42 3). Tears in the figurative sense of anxiety for the future are referred to in *Ps* 126 5; *Mk* 9 24 AV, and the tears accompanying penitence in *Lk* 7 38 (44 RVm). Jeremiah is sometimes called the "weeping prophet" on account of his expressive hyperbole in *Jer* 9 1.18 (see also 14 7; 31 16; *Lam* 1 2; 2 11.18 and ten other passages). Conversely the deliverance from grief or anxiety is described as the wiping away of tears (*Ps* 116 8; *Isa* 25 8; *Rev* 7 17; 21 4).

The expression in *Ps* 56 8 in which the Psalmist desires that God should remember his wanderings and his tears has given rise to a curious mistake. There is a paronomasia in the passage as he pleads that God should record his wanderings (*Heb nōdh*) and that his tears should be put into God's *nō'dh* (receptacle or bottle). *Nō'dh* lit. means a leathern or skin bottle, as is evident from *Ps* 119 83 and *Josh* 9 4-13. The request is obviously figurative, as there is no evidence that there was even a symbolical collection of tears into a bottle in any Sem funeral ritual, and there is no foundation whatever for the modern identification of the long, narrow perfume jars so frequently found in late Jewish and Gr-Jewish graves, as "lachrymatories" or tear bottles. See *BOTTLE*. ALEX. MACALISTER

**TEAT,** tēt (תֵּת, *shadh* [*Isa* 32 12], תֵּת, *dadh* [*Ezk* 23 3.21]): In all these passages the RV has replaced the word by "breast" or "bosom," both of which occasionally stand in poetical parallelism. The above passages in *Ezk* are to be understood figuratively of the inclination of Israel to connive

at, and take part in, the idolatry of their neighbors. To "smite upon the breasts" (Isa 32 12, where the AV translates wrongly "lament for the teats") means "to mourn and grieve in the ostentatious way of oriental women." See PAP.

**TEBAH**, tē'ba (טֶבַח, *tebhah*): A son of Nahor, the brother of Abraham (Gen 22 24).

**TEBALIAH**, teb-a-lī'a, te-bal'ya (טְבַלְיָהוּ, *tēbhalyāhū*, "Yahweh hath dipped," i.e. "purified"; B, Ταββαλ, *Tablai*, A, Ταββαλας, *Tabelias*, Luc., Ταββαλ, *Tabēēl*): A Merarite gatekeeper (1 Ch 26 11). The name should perhaps read טְבַלְיָהוּ, *tēbhalyāhū*, "Yahweh is good" (possibly from טוֹבִיחוּ, misread טב־ל ירו, *tēbhalyāhū*). See TOBIJAH.

**TEBETH**, te-beth', tē'beth (טֶבֶת, *tēbhēth*): The tenth month of the Jewish year, corresponding to January (Est 2 16). See CALENDAR.

**TEHAPHNEHES**, tē-haf'nē-hēz. See TAHPAN-HES.

**TEHINNAH**, tē-hin'a (תְּחִנָּה, *tēhinnāh*, "supplication"; B, Θαμιάν, *Thaimān*, A, Θανά, *Thaná*, Luc., Θεεννά, *Theenná*): "The father of the city Nahash" (1 Ch 4 12). The verse seems to refer to some post-exilic Jewish settlement, but is utterly obscure.

**TEIL**, tēl, **TREE**: AV Isa 6 13=RV TEREBINTH (q.v.).

**TEKEL**, tē'kel (תֶּקֶל, *tēkēl*). See MENE, MENE, TEKEL, UPHARSIN.

**TEKOA**, tē-kō'a (תְּקוֹעַ, *tēkō'a*, or תְּקוּעָה, *tēkō'āh*; Θεκωε, *Thekōe*; AV *Tekoah*; one of David's mighty men, "Ira the son of Ikkesh,"

1. Scripture is called a Tekoite, tē-kō'it (תְּקוּעִי, *tēkō'it*; References *tēkō'it*; 2 S 23 26; 1 Ch 11 28; 27 9]; the "woman of Tekoa" [2 S 14 2] is in Heb תְּקוּעִית, *tēkō'it*; in Neh 3 5 mention is made of certain Tekoites, tē-kō'its (תְּקוּעִיִּם, *tēkō'im*), who repaired part of the walls of Jerus): From here came the "wise woman" brought by Joab to try and make a reconciliation between David and Absalom (2 S 14 2 f); it was one of the cities fortified by Rehoboam (2 Ch 11 6; Jos, *Ant*, VIII, ix, 1). The wilderness of Tekoa is mentioned (2 Ch 20 20) as the extreme edge of the inhabited area; here Jehoshaphat took counsel before advancing into the wilderness of Judaea to confront the Ammonites and Moabites. In Jer 6 1, we read, "Blow the trumpet in Tekoa and raise a signal in Beth-haccherim"—because of the enemy advancing from the N. Amos (1 1), one of the "herdsmen of Tekoa," was born here.

In Josh 15 59 (addition to verse in LXX only) Tekoa occurs at the beginning of the list of 11 additional cities of Judah—a list which includes Bethlehem, Ain Kairem and Bettir—which are omitted in the Hebrew. A Tekoa is mentioned as a son of Ashhur (1 Ch 2 24; 4 5).

Jonathan Maccabaeus and his brother Simon fled from the vengeance of Bacchides "into the wilderness of Thecoe [RV "Tekoah"] and pitched their tents [RV "encamped"] by the water of the pool Asphar" (1 Macc 9 33).

Jos calls Tekoa a village in his day (*Vita*, 75), as does Jerome who describes it as 12 miles from Jerus and visible from Bethlehem; he says the tomb of the prophet Amos was there (*Comm. on Jeremiah*, VI, 1). "There was," he says, "no village

beyond Tekoa in the direction of the wilderness." The good quality of its oil and honey is praised by other writers. In the 6th cent. a monastery, Laura Nova, was founded there by St. Saba. In the crusading times Tekoa was visited by pious pilgrims wishing to see the tomb of Amos, and some of the Christian inhabitants assisted the Crusaders in the first siege of Jerus. In 1138 the place was pillaged by a party of Turks from the E. of the Jordan, and since that time the site appears to have lain desolate and ruined, although even in the 14th cent. the tomb of Amos was still shown.

The site is without doubt the *Kh. Tekū'a*, a very extensive ruin, covering 4 or 5 acres, about 6 miles S. of Bethlehem and 10 miles

3. The from Jerus, near the Frank Mountain Site *Tekū'a* and on the road to *Ain Jidy*. The remains on the surface are chiefly of large cut stone and are all, apparently, mediaeval. Fragments of pillars and bases of good hard limestone occur on the top of the hill, and there is an octagonal font of rose-red limestone; it is clear that the church once stood there. There are many tombs and cisterns in the neighborhood of a much earlier period. A spring is said to exist somewhere on the site, but if so it is buried out of sight. There is a reference in the "Life of Saladin" (Bahaoddenu), to the "river of Tekoa," from which Richard Coeur de Lion and his army drank, 3 miles from Jerus: this may refer to the 'Arab extension of the "low-level aqueduct" which passes through a long tunnel under the *Sahl Tekū'a* and may have been thought by some to rise there.

The open fields around *Tekū'a* are attractive and well suited for olive trees (which have now disappeared), and there are extensive grazing-lands. The neighborhood, even the "wilderness" to the E., is full of the flocks of wandering Bedouin. From the site, Bethlehem, the Mount of Olives and *Nebi Samuel* (Mizpah) are all visible; to the N.E. is a peep of the Jordan valley near Jericho and of the mountains of Gilead, but most of the eastern outlook is cut off by rising ground (*PEF*, III, 314, 368, Sh XXI). E. W. G. MASTERMAN

**TEL-ABIB**, tel-ā'bib (תֵּל אַבִּיב, *tēl'ābhīb*; Vulg *ad acervum novarum frugum*): As written in Heb, Tel-abib means "hill of barley-cars"

1. The and is mentioned in Ezk 3 15 as the Name and place to which the prophet went, Its Meaning and where he found Jewish captives "that dwelt by the river Chebar." That Tel-abib is written, as Fried. Delitzsch suggests, for *Til Abūbi*, "Mound of the Flood" (which may have been a not uncommon village-name in Babylonia) is uncertain. Moreover, if the captives themselves were the authors of the name, it is more likely to have been in the Heb language. LXX, which has *metēoros*, "passing on high," referring to the manner in which the prophet reached Tel-abib, must have had a different Heb reading.

If the Chebar be the *nār Kabari*, as suggested by Hilprecht, Tel-abib must have been situated somewhere in the neighborhood of Niffer, the city identified with the Calneh of Position Gen 10 10. The tablet mentioning the of the river *Kabaru* refers to grain (barley?) Settlement seemingly sent by boat from Niffer in Nišan of the 21st year of Artaxerxes I. Being a navigable waterway, this was probably a good trading-center.

LITERATURE.—See Hilprecht and Clay, *Business Documents of Murashū Sons* ("Pennsylvania Exp.," Vol IX, 28); Clay, *Light on the OT from Babel*, 405.

T. G. FINCHES

**TEL-HARSHA**, tel-hār'sha (תֵּל־חַרְשָׁה, *tēl-har-shā'*): In Ezr 2 59; Neh 7 61 (AV in latter, "Tel-haresha," tel-ha-rē'sha, -har'ē-sha), a Bab town or village from which Jews who could not show their lineage returned with Zerubbabel. The site is unknown. In 1 Esd 5 36 it is called "Thelersas."

**TELAH**, tē'la (תֵּלַח, *tēlah*; B, Θάλεες, *Thálees*, A, Θάλαε, *Thále*, Luc., Θάλα, *Thála*): An Ephraimite (1 Ch 7 25).

**TELAIM**, tē-lā'im (תֵּילָיִם, *hā-tē-lā'im*, "the young lambs"; ἐν Γαλαγαίοις, *en Galgáiois*): The place where Saul "summoned the people, and numbered them" (1 S 15 4) before his attack on Agag, king of the Amalekites. Some authorities read "Telām" for "Havilah" in ver 7 and also find this name in 1 S 27 8 instead of מַעְוֹלָם, *mē'ōlām*. In LXX and Jos (*Ant*, VI, vii, 2) Gilgal occurs instead of Telaim, on what ground is not known. Probably Telaim is identical with TELEM (q.v.), though the former may have been the name of a Bedouin tribe inhabiting the latter district. Cf *Dhallām* Arabs now found S. of *Tell el-Milh*.  
E. W. G. MASTERMAN

**TELISSAR**, tē-las'ar (תֵּלִיסָר, *tēlissār* [2 K 19 12], תֵּלִיסָר, *tēlissār* [Isa 37 12]; A, Θαλασσάρ, *Thalassár*, B, Θαεσθέν, *Thaesthén*;

**1. The Name and Its Meaning** Vulg *Thelassar*, *Thalassar*): This city, which is referred to by Sennacherib's messengers to Hezekiah, is stated by the "children of Eden." It had been captured by the Assy king's forefathers, from whose hands its gods had been unable to save it. Notwithstanding the vocalization, the name is generally rendered "Hill of Asshur," the chief god of the Assyrians, but "Hill of Assār," or *Asari* (a name of the Bab Merodach), would probably be better.

As Telassar was inhabited by the "children of Eden," and is mentioned with Gozan, Haran, and Rezep, in Western Mesopotamia, it has been suggested that it lay in Bit-Adini, "the House of Adinu," or Beth-eden, in the same direction, between the Euphrates and the Belikh. A place named *Til-Aššuri*, however, is twice mentioned by Tiglath-pileser IV (*Ann.*, 176; *Slab-Inscr.*, II, 23), and from these passages it would seem to have lain near enough to the Assy border to be annexed. The king states that he made there holy sacrifices to Merodach, whose seat it was. It was inhabited by Babylonians (whose home was the *Edinu* or "plain"; see EDEN). Esarhaddon, Sennacherib's son, who likewise conquered the place, writes the name *Til-Aššuri*, and states that the people of Mihrānu called it *Pitānu*. Its inhabitants, he says, were people of *Barnaku*. If this be *Bit Burnaki* in Elam, extending from the boundary of *Rāšū* (see ROSH), which was ravaged by Sennacherib (*Bab Chron.*, III, 10 ff), *Til-Aššuri* probably lay near the western border of Elam. Should this identification be the true one, the Heb form *tēlissār* would seem to be more correct than the Assy *Til-Aššuri* (-*Aššuri*), which latter may have been due to the popular idea that the second element was the name of the national god *Aššur*. See Fr. Delitzsch, *Wo lag das Paradies?* 264.  
T. G. PINCHES

**TELEM**, tē'lem (תֵּלֵם, *tēlem*; Tέλεμ, *Télem*): A city in the Negeb "toward the border of Edom," belonging to Judah (Josh 15 24). In LXX of 2 S 3 12 Abner is said to send messengers to David at *Thelam* (Θαλάμ, *Thailám*); this would seem to be

the same place and also to be identical with the Telaim and Telam of Saul (see TELAIM). It is probably the same as the Talmia of the Talm (*Neubauer, Géog. du Talm*, 121). The site has not been recovered.

**TELEM** (תֵּלֵם, *tēlem*; LXX B, Tέλεμ, *Télem*, A, Tέλλημ, *Téllēm*): One of three "porters" who had married foreign wives (Ezr 10 24), his name appearing as "Tolbanes" in 1 Esd 9 25; perhaps the same as TALMON (q.v.).

**TELL**. See TALE.

**TELL EL-AMARNA**, tel-el-a-mār'na, TABLETS:

- I. INTRODUCTION
  - 1. Name
  - 2. Discovery
  - 3. Physical Character
- II. EPIGRAPHICAL VALUE
  - 1. Peculiar Cuneiform Script
  - 2. Method of Writing Proper Names
- III. PHILOLOGICAL VALUE
  - 1. Knowledge of Amorite, Hittite and Mitannian Tongues
  - 2. Persistence of Canaanite Names to the Present Time
  - 3. Verification of Biblical Statements concerning "the Language of Canaan"
- IV. GEOGRAPHICAL VALUE
  - 1. Political and Ethnological Lines and Locations
  - 2. Verification of Biblical and Egyptian Geographical Notices
  - 3. Confirmation of General Evidential Value of Ancient Geographical Notes of Bible Lands
- V. HISTORICAL VALUE
  - 1. Revolutionary Change of Opinion concerning Canaanite Civilization in Patriarchal Times
  - 2. Anomalous Historical Situation Revealed by Use of Cuneiform Script
  - 3. Extensive Diplomatic Correspondence of the Age
  - 4. Unsolved Problem of the *Habiri*

LITERATURE

A collection of about 350 inscribed clay tablets from Egypt, but written in the cuneiform writing, being part of the royal archives of Amenophis III and Amenophis IV, kings of the XVIIIth Egyp Dynasty about 1480 to 1460 BC. Some of the tablets are broken and there is a little uncertainty concerning the exact number of separate letters. 81 are in the British Museum=BM; 160 in the New Babylonian and Assyrian Museum, Berlin=B; 60 in the Cairo Museum=C; 20 at Oxford=O; the remainder, 20 or more, are in other museums or in private collections.

**1. Introduction.**—The name, *Tell el-Amarna*, "the hill Amarna," is the modern name of ancient ruins about midway between Memphis and Luxor in Egypt. The ruins mark the site of the ancient city Khut

Aten, which Amenophis IV built in order to escape the predominant influence of the old religion of Egypt represented by the priesthood at Thebes, and to establish a new cult, the worship of Aten, the sun's disk.

In 1887 a peasant woman, digging in the ruins of *Tell el-Amarna* for the dust of ancient buildings with which to fertilize her garden,

**2. Discovery.**—She found tablets, a portion of the royal archives. She filled her basket with tablets and went home. How many she had already pulverized and grown into leeks and cucumbers and melons will never be known. This time someone's curiosity was aroused, and a native dealer secured the tablets. Knowledge of the "find" reached Rev. Chauncey Murch, D.D., an American missionary stationed at Luxor, who, suspecting the importance of the tablets, called the attention of cuneiform scholars to them. Then began a short but intense and bitter contest between representatives of various museums on the one hand, eager for scientific material, and native deal-

ers, on the other hand, rapacious at the prospect of the fabulous price the curious tablets might bring. The contest resulted in the destruction of some of the tablets by ignorant natives and the final distribution of the remainder and of the broken fragments, as noted at the beginning of this art. (see also Budge, *Hist of Egypt*, IV, 186). After the discovery of the tablets the site of the ancient city was excavated by Professor Petrie in 1891-92 (*Tell el-Amarna*; cf also Baedeker, *Egypt*).

The physical character of the tablets is worthy of some notice. They are clay tablets. Nearly all are brick tablets, i.e. roctangular, flat tablets

**3. Physical Character**

varying in size from 2x2½ in. to 3½x9 in., inscribed on both sides and sometimes upon the edges. One tablet is of a convex form (B 1601). The clay used in the tablets also varies much. The tablets of the royal correspondence from Babylonia and one tablet from Mitanni (B 153) are of fine Bab clay. The Syrian and Palestinian correspondence is in one or two instances of clay which was probably imported from Babylonia for correspondence, but for the most part these tablets are upon the clay of the country and they show decided differences among themselves in color and texture: in some instances the clay is sandy and decidedly inferior. A number of tablets have red points, a kind of punctuation for marking the separation into words, probably inserted by the Egypt translator of the letters at the court of the Pharaoh. These points were for the purpose of assisting in the reading. They do now assist the reading very much. Some tablets also show the hieroglyphic marks which the Egypt scribe put on them when filing them among the archives. The writing also is varied. Some of the tablets from Pal (B 328, 330, 331) are crudely written. Others of the letters, as in the royal correspondence from Babylonia, are beautifully written. These latter (B 149-52) seem to have been written in a totally different way from the others; those from Western Asia appear to have been written with the stylus held as we commonly hold a pen, but the royal letters from Babylonia were written by turning the point of the stylus to the left and the other end to the right over the second joint of the first finger.

The results of the discovery of the Am Tab have been far-reaching, and there are indications of still other benefits which may yet accrue from them. The discovery of them shares with the discovery of the CH the distinction of the first place among Bib. discoveries of the past half-century.

**II. Epigraphical Value.**—The peculiar use of the cuneiform method of writing in these tablets

**1. Peculiar Cuneiform Script**

in order to adapt it to the requirements of a strange land having a native tongue, and the demands made upon it for the representation of proper names of a foreign tongue, have already furnished the basis for the opinion that the same cuneiform method of writing was employed originally in other documents, esp. some portions of the Bible and much material for Egypt governmental reports. It is not improbable that by means of such data furnished by the tablets definite clues may be obtained to the method of writing, and by that also approximately the time of the composition, of the literary sources that were drawn upon in the composition of the Pent, and even of the Pent itself (cf esp. Naville, *Archaeology of the Bible*).

Most of the letters were probably written by Egypt officers or, more frequently, by scribes in the employ of native appointees of the

**2. Proper Names**

Egypt government. The writing of so many proper names by these scribes in the cuneiform script has thrown a flood of light upon the spelling of Canaanite names by Egypt scribes in the hieroglyphic inscriptions of Egypt. It is evident now that certainly some, perhaps most, of these scribes worked from cuneiform lists (Müller, *Egyptological Researches*, 1906, 40). As the system of representation of Palestinian names by Egypt scribes becomes thus better understood, the identification of more and more of the places in Pal named in the Egypt inscriptions becomes possible. Every such identification makes

more nearly perfect the identification of Bib. places, the first and most important item in historical evidence.

**III. Philological Value.**—No other literary discovery, indeed, not all the others together, have

afforded so much light upon philological problems in patriarchal Pal as the Am Tab. Something is now really definitely known of "the language of Canaan," the speech of the people of patriarchal days in Pal. The remarkable persistence of old Canaanite words and names and forms of speech of these tablets down to the present time makes it plain that the peasant speech of today is the lineal descendant of that of Abraham's day. The letters are in the Bab tongue modified by contact with the speech of the country, a kind of early Aram. (Conder, *The Tell Amarna Tablets*, X; Dhorme, "La langue de Canaan," *Revue Biblique*, Juillet, 1913, 369). There are also frequent Canaanite words inserted as glosses to explain the Bab words (Dhorme, op. cit.).

The facts evinced by the persistence of the early Canaanite speech (cf I, above) down through all the centuries to the peasant speech of Pal

**2. Persistence of Canaanite Names**

of today furnishes a verification of the Bib. reference to the "language of Canaan" (Isa 19 18). That peasant speech is, as it manifestly has always been since patriarchal times, a Sem tongue. Now, even so adventurous a work as a grammar of the ancient Canaanite language has been attempted, based almost entirely upon the material furnished by the Am Tab (Dhorme, op. cit.), in which the speech of Pal in patriarchal days is described as "ancient Canaanite or Hebrew."

Some more specific knowledge is also supplied by the Am Tab concerning the Amorite language

**3. Verification of Biblical Statements**

through the many Amorite names and the occasional explanations given in Amorite words (cf esp. the 50 letters of Ribadda), and some knowledge of Hittite (Letter of Tarkhundara; Conder, *The Tell Amarna Tablets*, 225 f), concerning the Mitannian tongue (B 153, 190, 191, 233). One other tablet (B 342) is in an unknown tongue.

**IV. Geographical Value.**—There was a very wide international horizon in the days of the correspondence contained in the Am Tab,

**1. International Horizon**

a horizon that inclosed Egypt, Babylonia, Canaan, Mitanni and the land of the Hittites; but the more definite geographical information supplied by the tablets is limited almost entirely to the great Syrian and Canaanite coast land. There is difference of opinion concerning the identification of a few of the places mentioned, but about 90 have been identified with reasonable certainty.

It is possible now to trace the course of the military operations mentioned in the Am Tab with almost as much satisfaction as the

**2. Biblical Verification**

course of a modern military campaign, and there is much verification also of Bib. and Egypt geographical notices.

The identification of such a large number of places and the ability thus given to trace the course of historical movements in that remote

**3. Geographical Confirmation**

age are a remarkable testimony to the historical value of ancient records of that part of the world, for accuracy concerning place is of first importance in historical records.

**V. Historical Value.**—The Am Tab furnish an amount of historical material about equal in bulk to one-half of the Pent. While much of this bears more particularly upon general history of the an-

cient Orient, there is scarcely any part of it which does not directly or indirectly supply information which parallels some phase of Bib. history. It is not certain that any individual mentioned in the Bible is mentioned in these tablets, yet it is possible, many think it well established, that many of the persons and events of the conquest period are mentioned (cf 4 [1], below). There is also much that reflects the civilization of times still imperfectly understood, reveals historical events hitherto unknown, or but little known, and gives many sidelights upon the movements of nations and peoples of whom there is something said in the Bible.

A revolutionary change of opinion concerning the civilization of patriarchal Pal has taken place. It was formerly the view of all classes of scholars, from the most conservative, its Civiliza- tion on the one hand, to the most radical, on the other, that there was a very crude state of civilization in Pal in the patriarchal age, and this entirely independent of, and indeed prior to, any demand made by the evolutionary theory of Israel's history. Abraham was pictured as a pioneer from a land of culture to a distant dark place in the world, and his descendants down to the descent into Egypt were thought to have battled with semi-barbarous conditions, and to have returned to conquer such a land and bring civilization into it. All this opinion is now changed, primarily by the information contained in the Am Tab and secondarily by incidental hints from Egypt and Bab inscriptions now seen to support the high stage of civilization revealed in the Am Tab (see ARCHAEOLOGY AND CRITICISM). The tablets make mention of " 'capital cities,' 'provincial cities,' 'fortresses,' 'towns,' and 'villages' with 'camps' and Hazors (or inclosures); while irrigation of gardens is also noticed, and the papyrus grown at Gebal, as well as copper, tin, gold, silver, agate, money (not, of course, coins) and precious objects of many kinds, mulberries, olives, corn, ships and chariots" (Conder, op. cit., 4).

The account of a bride's marriage portion from Mitanni reveals conditions farther north: "Two horses, and a chariot plated with gold and silver, and adorned with precious stones. The harness of the horses was adorned in like manner. Two camel liters appear to be next noticed, and apparently variegated garments worked with gold, and embroidered zones and shawls. These are followed by lists of precious stones, and a horse's saddle adorned with gold eagles. A necklace of solid gold and gems, a bracelet of iron gilt, an anklet of solid gold, and other gold objects follow; and apparently cloths, and silver objects, and vases of copper or bronze. An object of jade or Jasper and leaves of gold. Five gems of 'stone of the great light' (probably diamonds) follow, with ornaments for the head and feet, and a number of bronze objects and harness for chariots" (ib, 188-89). The record of Thothmes III concerning booty brought from Pal fully confirms this representation of the tablets (Birch, *Records of the Past*, 1st ser., II, 35-52; cf Sayce, *Archaeology of the Cuneiform Inscriptions*, 156-57).

The Bab inscriptions show that Abraham was a part of an emigration movement from the homeland to a frontier province, having the same laws and much of the same culture (Lyon, *American Oriental Society Journal*, XXV, 254; Barton, *American Philosophical Proceedings*, LII, no. 209, April, 1913, 197; Kyle, *Deciding Voice of the Monuments in Bib. Criticism*, ch xv). The Egypt sculptured pictures make clear that the civilization of Pal in patriarchal times was fully equal to that of Egypt (cf Petrie, *Deshasheh*, pl. IV).

That these things of elegance and skill are not merely the trappings of "barbaric splendor" is manifest from the revelation which the Am Tab make of ethnic movements and of influences at work from the great nations on either side of Canaan, making it impossible that the land could have been, at that period, other than a place of advanced civiliza-

tion. Nearly all the tablets furnish most unequivocal evidence that Egypt had imperial rule over the land through a provincial government which was at the time falling into decay, while the cuneiform method of writing used in the tablets by such a variety of persons, in such high and low estate, implying thus long-established literary culture and a general diffusion of the knowledge of a most difficult system of writing, makes it clear that the civilization of Babylonia had been well established before the political power of Egypt came to displace that of Babylonia.

The displacement of Bab political power in Pal just mentioned (1, above) points at once to a most remarkable historical situation revealed by the Am Tab, i.e. official Egypt correspondence between the outlying province of Canaan and the imperial government at home, carried on, not in the language and script of Egypt, but in the script of Babylonia and in a language that is a modified Babylonian. This marks one step in the great, age-long conflict between the East and the West, between Babylonia and Egypt, with Canaan as the football of empires. It reveals—what the Bab inscriptions confirm—the long-preceding occupation of Canaan by Babylonia, continuing down to the beginning of patriarchal times, which had so given Canaan a Bab stamp that the subsequent political occupation of the land by Egypt under Thothmes III had not yet been able to efface the old stamp or give a new impression.

The extensive diplomatic correspondence between nations so widely separated as Egypt on the W., and Babylonia on the E., Mitanni on the N., and the Hittite country on the N.W., is also shown by the Am Tab. In addition to the large number of letters between Canaan and Egypt, there are quite a number of these royal tablets: letters from Kadashman Bell, or Kallima-Sin (BM 29784), and Burna-burias of Babylonia (B 149-52), Assur-uballidh of Assyria and Dusratta of Mitanni (B 150, 191-92, 233), etc. There seems at first sight a little pettiness about this international correspondence that is almost childish, since so much of it is occupied with the marriage of princesses and the payment of dowers, and the exchange of international gifts and privileges (Budge, *Hist of Egypt*, IV, 189-90). But one might be surprised at the amount of such things in the private correspondence of kings of the present day, if access to it could be gained. The grasping selfishness also revealed in these tablets by the constant cry for gold is, after all, but a less diplomatic and more frank expression of the commercial haggling between nations of today for advantages and concessions.

The subject of greatest historical interest in Bib. matters presented by the Am Tab is the great, unsolved problem of the *Habiri*. Unsolved it is, for while every writer on the subject has a very decided opinion of his own, all must admit that a problem is not solved upon which there is such wide and radical difference of opinion among capable scholars, and that not running along easy lines of cleavage, but dividing indiscriminately all classes of scholars.

(1) One view very early advanced and still strongly held by some (Conder, op. cit., 138-44) is that *Habiri* is to be read 'Abiri, and means the Hebrews. It is pointed out that the letters referring to these people are from Central and Southern Pal, that the *Habiri* had some relation with Mt. Seir, that they are represented as contemporaneous with Japhia king of Gezer, Jabin king of Hazor, and probably Adonizedek king of Jerus, contemporaries of Joshua, and that certain incidental movements of Israel and of the people of Pal mentioned in the Bible are also mentioned or assumed in the tablets (Conder, op. cit., 139-51). In reply to these arguments for the identification of the *Habiri* with the Hebrews under Joshua, it may be noted that,

## 2. Anomalous Historical Situation

## 3. Diplomatic Correspondence

## 4. Problem of the Habiri

although the letters which speak of the *Habiri* are all from Central or Southern Pal, they belong to very nearly the same time as the very numerous letters concerning the extensive wars in the N. The distinct separation of the one set of letters from the other is rather arbitrary and so creates an appearance which has little or no existence in fact. Probably these southern letters refer to the same disturbances spreading from the N. toward the S., which is fatal to the theory that the *Habiri* are the Hebrews under Joshua, for these latter came in from the S.E. The reference to Seir is obscure and seems rather to locate that place in the direction of Carmel (Conder, op. cit., 145). The mention of Japhia king of Gezer, and Jabin king of Hazor, does not signify much, for these names may be titles, or there may have been many kings, in sequence, of the same name. Concerning Adonizedek, it is difficult to believe that this reading of the name of the king of Jerus would ever have been thought of, except for the desire to identify the *Habiri* with the Hebrews under Joshua. This name Adonizedek is only made out, with much uncertainty, by the unusual method of translating the king's name instead of transliterating it. If the name was Adonizedek, why did not the scribe write it so, instead of translating it for the Pharaoh into an entirely different name because of its meaning? The seeming correspondences between the letters and the account of the conquest in the Bible lose much of their significance when the greater probabilities raised in the names and the course of the wars are taken away.

(2) Against the view that the *Habiri* were the Hebrews of the Bible may be cited not only these discrepancies in the evidence presented for that view (cf [1], above), but also the very strong evidence from Egypt that the Exodus took place in the Ramesside dynasties, thus not earlier than the XIXth Dynasty and probably under Merenptah, the successor of Rameses II. The name Rameses for one of the store cities could hardly have occurred before the Ramesside kings. The positive declaration of Rameses II: "I built Pithom," against which there is no evidence whatever, and the coincidence between the Israel tablet of Merenptah (Petrie, *Six Temples at Thebes*, 28, pls. XIII-XIV) and the Bib. record of the Exodus, which makes the 5th year under Merenptah to be the 5th year of Moses' leadership (see *Moses*), make it very difficult, indeed seemingly impossible, to accept the *Habiri* as the Hebrews of the conquest.

(3) Another view concerning the *Habiri*, strongly urged by some (Sayce, *The Higher Criticism and the Verdict of the Monuments*, 175 ff), is that they are *Habiri*, not *Abiri*, and that the name means "confederates," and was not a personal or tribal name at all. The certainty that there was, just a little before this time, an alliance in conspiracy among the Amorites and others, as revealed in the tablets for the region farther north, gives much color to this view. This opinion also relieves the chronological difficulties which beset the view that the *Habiri* were the Bib. Hebrews (cf [2], above), but it is contended that this reading does violence to the text.

(4) Another most ingenious view is advanced by Jeremias (*The OT in the Light of the Ancient East*, 341), that the name is *Habiri*, that "the name answers to the sounds of 'Hebrews,' and that the names are identical," but that this name in the Am Tab is not a proper name at all, but a descriptive word, as when we read of "Abraham the Hebrew," i.e. the "stranger" or "immigrant." Thus *Habiri* would be "Hebrews," i.e. "strangers" or "immigrants" (see *HEBERITES; HEBREW*), but the later question of the identification of these with the Hebrews of the Bible is still an open question.

(5) It may be that the final solution of the prob-

lem presented by the *Habiri* will be found in the direction indicated by combining the view that sees in them only "strangers" with the view that sees them to be "confederates." There were undoubtedly "confederates" in conspiracy against Egypt in the time of the Am Tab. The government of Egypt did not come successfully to the relief of the beleaguered province, but weakly yielded. During the time between the writing of the tablets and the days of Merenptah and the building of Pithom no great strong government from either Egypt or Babylonia or the N. was established in Pal. At the time of the conquest there is constant reference made to "the Hittites and the Amorites and the Perizzites," etc. Why are they so constantly mentioned as a group, unless they were in some sense "confederates"? It is not impossible, indeed it is probable, that these Hittites and Amorites and Perizzites, etc, Palestinian tribes having some kind of loose confederacy in the days of the conquest, represent the last state of the "confederates," the conspirators, who began operations in the Amorite war against the imperial Egypt government recorded in the Am Tab, and, in the correspondence from the S., were called in those days *Habiri*, i.e. "strangers" or "immigrants." For the final decision on the problem of the *Habiri* and the full elucidation of many things in the Am Tab we must await further study of the tablets by expert cuneiform scholars, and esp. further discovery in contemporary history.

The Jerus letters of the southern correspondence present something of much importance which does not bear at all upon the problem of the *Habiri*. The frequently recurring title of the king of Jerus, "It was not my father, it was not my mother, who established me in this position" (Budge, *Hist of Egypt*, IV, 231-35), seems to throw light upon the strange description given of MELCHIZEDEK (q.v.), the king of Jerus in the days of Abraham. The meaning here clearly is that the crown was not hereditary, but went by appointment, the Pharaoh of Egypt having the appointing power. Thus the king as such had no ancestor and no descendant, thus furnishing the peculiar characteristics made use of to describe the character of the Messiah's priesthood in the Ep. to the He (7 3).

LITERATURE.—Conder, *The Tell Amarna Tablets*; Knudtzon, *Die El-Amarna-Tafeln*, in Heinrich's *Vorderasiatische Bibliothek*, II; Petrie, *Tell el Amarna Tablets*; idem, *Syria and Egypt from the Tell el Amarna Letters*; idem, *Hist of Egypt*; Jeremias, *The OT in the Light of the Ancient East*.

M. G. KYLE

**TEL-MELAH**, tel-mē'la (תֵּל־מֶלַח, *tēl-melah*, "hill of salt"): A Bab town mentioned in Ezr 2 59; Neh 7 61 with Tel-harsha and Cherub (see *TEL-HARSHA*). It possibly lay on the low salt tract near the Pers Gulf. In 1 Esd 5 36 it is called "Thermeleth."

**TEMA**, tē'ma (תֵּמָא, *tēmā*, "south country"; *Θαίμας, Thaimán*): The name of a son of Ishmael (Gen 25 15; 1 Ch 1 30), of the tribe descended from him (Jer 25 23), and of the place where they dwelt (Job 6 19; Isa 21 14). This last was a locality in Arabia which probably corresponds to the modern *Teimā'* (or *Taymā'* [see Doughty, *Arabia Deserta*, I, 285]), an oasis which lies about 200 miles N. of *el-Medina*, and some 40 miles S. of *Dūmat el-Jandal* (Dumah), now known as *el-Jauf*. It is on the ancient caravan road connecting the Pers Gulf with the Gulf of Akaba; and doubtless the people took a share in the carrying trade (Job 6 19). The wells of the oasis still attract the wanderers from the parched wastes (Isa 21 14). Doughty (loc. cit.) describes the ruins of the old city wall, some 3 miles in circuit. An Aram. stele recently



discovered, belonging to the 6th cent. BC, shows the influence of Assyr art. The place is mentioned in the cuneiform inscriptions (Schrader, *KAT*<sup>2</sup>, 149).

W. EWING

**TEMAH**, tē'ma (תֵּמָחַ, *temah*; A B, **Θέμα**, *Théma*, Luc., **Θεμαά**, *Themadā*; Neh 7 55, B, **Ἡμαθ**, *Hēmāth*, A, **Θήμα**, *Théma*, Luc., **Θεμαά**, *Themadā*; AV **Thamah**): The family name of a company of Nethinim (Ezr 2 53).

**TEMAN**, tē'man (תֵּמָנִי, *tēmān*, "on the right," i.e. "south"; **Θαιμάν**, *Thaimān*): The name of a district and town in the land of Edom, named after Teman the grandson of Esau, the son of his first-born, Eliphaz (Gen 36 11; 1 Ch 1 36). A duke Teman is named among the chiefs or clans of Edom (Gen 36 42; 1 Ch 1 53). He does not however appear first, in the place of the firstborn. Husham of the land of the Temanites was one of the ancient kings of Edom (Gen 36 34; 1 Ch 1 45). From Ob ver 9 we gather that Teman was in the land of Esau (Edom). In Am 1 12 it is named along with Bozrah, the capital of Edom. In Ezk 25 13 desolation is denounced upon Edom: "From Teman even unto Dedan shall they fall by the sword." Dedan being in the S., Teman must be sought in the N. *Onom* knows a district in the Gebalene region called Theman, and also a town with the same name, occupied by a Rom garrison, 15 miles from Petra. Unfortunately no indication of direction is given. No trace of the name has yet been found. It may have been on the road from Elath to Bozrah.

The inhabitants of Teman seem to have been famous for their wisdom (Jer 49 7; Ob vs 8 f). Eliphaz the Temanite was chief of the comforters of Job (2 11, etc). The manner in which the city is mentioned by the prophets, now by itself, and again as standing for Edom, shows how important it must have been in their time.

W. EWING

**TEMENI**, tem'ē-nī, tē'mē-nī (תֵּמָנִי, *tēmēnī*, Baer, תֵּמָנִי, *tēmēnī*; BA, **Θαιμάν**, *Thaimān*, Luc., **Θαιμανελ**, *Thaimanēl*): The word תֵּמָנִי means a southerner, i.e. of Southern Judah; cf **TEMAN** (patronymic תֵּמָנִי, *tēmānī*), the name of Edom (Gen 36 11, etc), the "son" of Ashhur (1 Ch 4 6).

**TEMPER**, tem'pēr: The word is used in AV to render different Heb words. In Ezk 46 14 for "temper" (טָפַח, *raṣaṣ*) RV substitutes "moisten." In Cant (5 2) a noun from the same stem means "dewdrops." In Ex 29 2 AV we read "cakes unleavened, tempered (בָּלַל, *bālal*, lit. "mixed"] with oil." RV "mingled." The word denotes "rough-and-ready mixing." In the recipe for the making of incense given in Ex (30 35) occur the words "tempered together," מָלַח, *mālāh* (lit. "salted"; hence RV "seasoned with salt"). The word occurs in two interesting connections in Wisd 15 7 (RV "knead") and 16 21. In 1 Cor 12 24 it occurs in EV as a rendering of the Gr word *συγκεράννυμι*, *sygkeránnymi*, which meant to "mix together." Paul is arguing in favor of the unity of the church and of coöperation on the part of individual members, and uses as an illustration the human body which consists of various organs with various functions. It is God, argues the apostle, who has "tempered," "compounded" or "blended," the body. Each member has its place and function and must contribute to the welfare of the whole frame. The same Gr word occurs in He 4 2. The author urges the necessity of faith in regard to the gospel. The unbelieving Israelites had derived no benefit from their hearing of the gospel because their hearing of it was not "mixed" with faith.

T. LEWIS

**TEMPERANCE**, tem'pēr-ans (ἐγκράτεια, *egkráteia*), **TEMPERATE**, tem'pēr-āt (ἐγκρατής, *egkratēs*, νηφάλιος, *nēphálios*, σώφρων, *sōphrōn*): ARV departs from AV and ERV by translating *egkráteia* "self-control" (Acts 24 25; Gal 5 23; 2 Pet 1 6; 1 Cor 9 25), following ERV in several of these passages. This meaning is in accordance with classical usage, Plato applying it to "mastery" not only of self, but of any object denoted by a genitive following. LXX applies it to the possession "of strongholds" (2 Macc 8 30; 10 15), "of a position" (10 17), "of the city" (13 13), "of wisdom" (Sir 6 27). The reflexive meaning of "self-mastery," "self-restraint," is equally well established in the classics and LXX. Thus, in the verbal form, it is found in Gen 43 31, for the self-restraint exercised by Joseph in the presence of his brethren, when they appeared before him as suppliants, and in 1 S 13 12, where Saul professes that he "forced" himself to do what was contrary to his desire. For patristic use of the term, see illustrations in Suicer's *Thesaurus Ecclesiasticus*, I, 1000 ff. Clement of Alexandria: "Not abstaining from all things, but using continently such things as one has judged should be used"; "such things as do not seem beyond right reason." Basil: "To avoid excess on both sides, so as neither by luxury to be confused, nor, by becoming sickly, to be disabled from doing what has been commanded." Chrysostom (on 1 Tim 1 8) applies it to "one mastering passion of tongue, hand and unbridled eyes." Ellicott and Eadie (on Gal 5 23) quote Diogenes Laertius to the effect that the word refers to "control over the stronger passions." In 1 Cor 9 25, Paul illustrates it by the training of an athlete, whose regimen is not only described in the *Ars Poetica* of Horace (412 ff), and in Epictetus (quoted in Alford on this passage), but can be learned of the many devotees and admirers of similar pursuits today.

The principle involved is that of the concentration of all man's powers and capabilities upon the one end of doing God's will, in and through whatever calling God appoints, and the renunciation of everything either wholly or to whatever degree necessary, however innocent or useful it may be in its proper place, that interferes with one's highest efficiency in this calling (1 Cor 10 31). Not limited to abstinence, it is rather the power and decision to abstain with reference to some fixed end, and the use of the impulses of physical, as servants for the moral, life. It does not refer to any one class of objects that meets us, but to all; to what concerns speech and judgment, as well as to what appeals to sense. It is properly an inner spiritual virtue, working into the outward life, incapable of being counterfeited or replaced by any abstinence limited to that which is external (*Augsburg Confession*, Arts. XXVI, XXVII). When its absence, however, is referred to as sin, the negative is generally more prominent than the positive side of temperance. The reference in Acts 24 25 is to chastity, and in 1 Cor 7 9, as the context shows, to the inner side of chastity. In 1 Tim 3 2.11; Tit 2 2, the word *nēphalios* has its original meaning as the opposite to "drunken" (see **SOBRIETY**; **DRINK**, **STRONG**). See also the treatises on ethics by Luthardt (both the *Compendium* and the *History*), Martensen, Koestlin and Häring on temperance, asceticism, continence.

H. E. JACOBS

**TEMPEST**, tem'pest (סְעָרָה, *sē'ārāh*, or שִׁעָרָה, *sē'ārāh*, "a whirlwind," זֶרֶם, *zērem*, "overflowing rain"; χεῖμῶν, *cheimōn*, θύελλα, *thiella*): Heavy storms of wind and rain are common in Pal and the Mediterranean. The storms particularly mentioned in the Bible are: (1) the 40 days' rain of

the great flood of Noah (Gen 7 4); (2) hail and rain as a plague in Egypt (Ex 9 18); (3) the great rain after the drought and the contest of Elijah on Carmel (1 K 18 45); (4) the tempest on the sea in the story of Jonah (1 4); (5) the storm on the Lake of Galilee when Jesus was awakened to calm the waves (Mt 8 24; Mk 4 37; Lk 8 23); (6) the storm causing the shipwreck of Paul at Melita (Acts 27 18). Frequent references are found to God's power over storm and use of the tempest in His anger: "He maketh the storm a calm" (Ps 107 29); He sends the "tempest of hail, a destroying storm" (Isa 28 2). See also Job 9 17; 21 18; Isa 30 30. Jeh overwhelms His enemies as with a storm: "She shall be visited of Jeh of hosts with thunder, and with earthquake, and great noise, with whirlwind and tempest" (Isa 29 6). Jeh is a "refuge from the storm" (Isa 25 4; 4 6).

ALFRED H. JOY

**TEMPLE**, tem'p'l (הֵיכָל, *hēkhāl*, "palace"; sometimes, as in 1 K 6 3.5, etc.; Ezk 41 1 15 ff, used for "the holy place" only; בַּיִת, *bayith*, "house," thus always in RV; ἱερόν, *hierón*, *vaós*, *naós*):

A. STRUCTURE AND HISTORY

I. SOLOMON'S TEMPLE

- I. INTRODUCTORY
  - 1. David's Project
  - 2. Plans and Preparations
  - 3. Character of the Building
  - 4. Site of the Temple
  - 5. Phoenician Assistance
- II. THE TEMPLE BUILDING
  - 1. In General
  - 2. Dimensions, Divisions and Adornments
  - 3. The Side-Chambers
  - 4. The Porch and Pillars
- III. COURTS, GATES AND ROYAL BUILDINGS
  - 1. The Inner Court
    - (1) Walls
    - (2) Gates
  - 2. The Great Court
  - 3. The Royal Buildings
- IV. FURNITURE OF THE TEMPLE
  - 1. The Sanctuary
    - (1) The *d'bhār*
    - (2) The *hēkhāl*
  - 2. The Court (Inner)
    - (1) The Altar
    - (2) The Molten (Bronze) Sea
    - (3) The Lavers and Their Bases
- V. HISTORY OF THE TEMPLE
  - 1. Building and Dedication
  - 2. Repeated Plunderings, etc
  - 3. Attempts at Reform
  - 4. Final Overthrow

II. EZEKIEL'S PROPHETIC SKETCH

- I. INTRODUCTORY
  - 1. Relation to History of Temple
  - 2. The Conception Unique and Ideal
  - 3. Its Symmetrical Measurements
- II. PLAN OF THE TEMPLE
  - 1. The Outer Court
  - 2. The Inner Court
  - 3. The Temple Building and Adjuncts

III. THE TEMPLE OF ZERUBABEL

- I. INTRODUCTORY
  - 1. The Decree of Cyrus
  - 2. Founding of the Temple
  - 3. Opposition and Completion of the Work
- II. THE TEMPLE STRUCTURE
  - 1. The House
  - 2. Its Divisions and Furniture
  - 3. Its Courts, Altar, etc
  - 4. Later Fortunes

IV. THE TEMPLE OF HEROD

- I. INTRODUCTORY
  - 1. Initiation of the Work
  - 2. Its Grandeur
  - 3. Authorities
  - 4. Measurements
- II. THE TEMPLE AND ITS COURTS
  - 1. Temple Area—Court of Gentiles
  - 2. Inner Sanctuary Inclosure
    - (1) Wall, *hēl*, *sōrēgh*. Gates
    - (2) Court of the Women
    - (3) Inner Courts: Court of Israel; Court of the Priests
    - (4) The Altar, etc

- 3. The Temple Building
  - (1) House and Porch
  - (2) *Hēkhāl* and *d'bhār*
  - (3) The Side-Chambers

III. NT ASSOCIATIONS OF HEROD'S TEMPLE

- 1. Earlier Incidents
- 2. Jesus in the Temple
- 3. The Passion-Week
- 4. Apostolic Church
- 5. The Temple in Christian Thought

LITERATURE

A. STRUCTURE AND HISTORY

I. SOLOMON'S TEMPLE

**I. Introductory.**—The tabernacle having lasted from the exodus till the commencement of the monarchy, it appeared to David to be

**1. David's Project** no longer fitting that the ark of God should dwell within curtains (it was then in a tent David had made for it on Zion: 2 S 6 17), while he himself dwelt in a cedar-lined house. The unsettled and unorganized state of the nation, which had hitherto necessitated a portable structure, had now given place to an established kingdom. The dwelling of Jeh should therefore be henceforth a permanent building, situated at the center of the nation's life, and "exceeding magnificent" (1 Ch 22 5), as befitted the glory of Jeh, and the prospects of the state.

David, however, while honored for his purpose, was not permitted, because he had been a man of war (2 S 7; 1 Ch 22 8; cf 1 K 5 3),

**2. Plans and Preparations** to execute the work, and the building of the house was reserved for his son, Solomon. According to the Chronicler, David busied himself in making extensive and costly preparations of wood, stone, gold, silver, etc, for the future sanctuary and its vessels, even leaving behind him full and minute plans of the whole scheme of the building and its contents, divinely communicated (1 Ch 22 2 ff; 28 11 ff; 29). The general fact of lengthened preparation, and even of designs, for a structure which so deeply occupied his thoughts, is extremely probable (cf 1 K 7 51).

The general outline of the structure was based on that of the tabernacle (on the modern critical reversal of this relation, see under B,

**3. Character of the Building** below). The dimensions are in the main twice those of the tabernacle, though it will be seen below that there are important exceptions to this rule,

on which the critics found so much. The old question (see TABERNACLE) as to the shape of the building—flat or gable-roofed—here again arises. Not a few modern writers (Fergusson, Schick, Caldecott, etc), with some older, favor the tent-like shape, with sloping roof. It does not follow, however, even if this form is, with these writers, admitted for the tabernacle—a "tent"—that it is applicable, or likely, for a stone "house," and the measurements of the Temple, and mention of a "ceiling" (1 K 6 15), point in the opposite direction. It must still be granted that, with the scanty data at command, all reconstructions of the Solomonic Temple leave much to be filled in from conjecture. Rev. Joseph Hammond has justly said: "It is certain that, were a true restoration of the Temple ever to be placed in our hands, we should find that it differed widely from all attempted 'restorations' of the edifice, based on the scanty and imperfect notices of our historian and Ezk" (*Comm.* on 1 K 6, "Pulpit Comm.").

The site of the Temple was on the eastern of the two hills on which Jerus was built—that known in Scripture as Mt. Moriah (2 Ch 3 1)

**4. Site of the Temple** or Mt. Zion (the traditional view which locates Zion on the western hill, on the other side of the Tyropœon, though defended by some, seems untenable; see

SOLOMON'S TEMPLE (SCHICK'S MODEL)

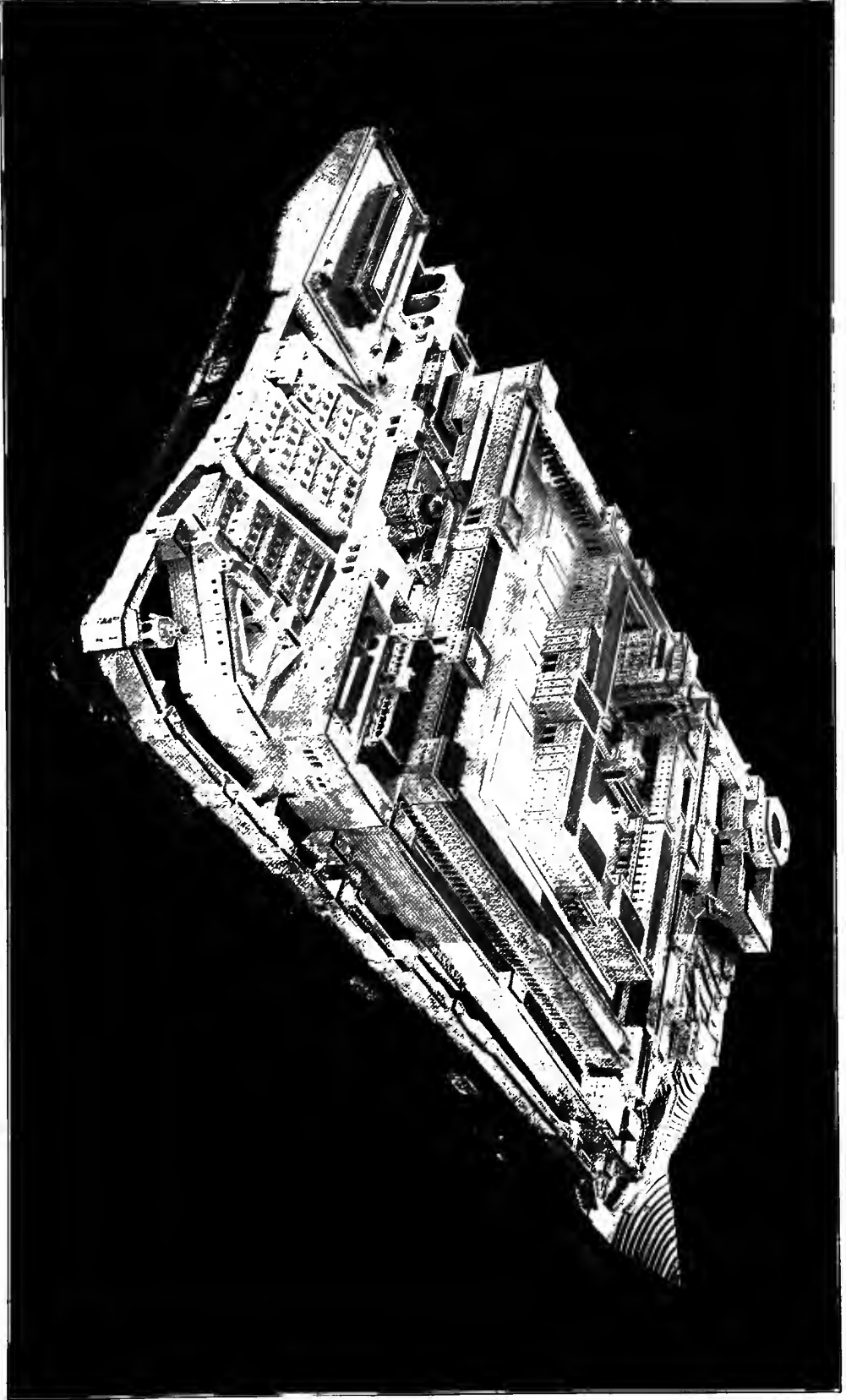



"Zion," in *HDB*; "Jerusalem," in *DB*, etc). The place is more precisely defined as that where Araunah (Ornan) had his threshing-floor, and David built his altar after the plague (1 Ch 21 22; 2 Ch 3 1). This spot, in turn, is now all but universally held to be marked by the sacred rock, *es-sakhrah* (within what is called the *Haram* area on the eastern summit; see *JERUSALEM*), above which the "Dome of the Rock," or so-called "Mosque of Omar," now stands. Here, according to traditional belief, was reared the altar of burnt offering, and to the W. of it was built the Temple. This location is indeed challenged by Fergusson, W. R. Smith, and others, who transfer the Temple-site to the southwestern angle of the *Haram* area, but the great majority of scholars take the above view. To prepare a suitable surface for the Temple and connected buildings (the area may have been some 600 ft. E. to W., and 300 to 400 ft. N. to S.), the summit of the hill had to be leveled, and its lower parts heightened by immense substructures (Jos, *Ant.*, VIII, iii, 9; XV, xi, 3; *BJ*, V, v, 1), the remains of which modern excavations have brought to light (cf Warren's *Underground Jerus.*; G. A. Smith's *Jerus.*, etc).

For aid in his undertaking, Solomon invited the cooperation of Hiram, king of Tyre, who willingly lent his assistance, as he had before helped David, granting Solomon per-  
**5. Phoenician Assistance** mission to send his servants to cut down timber in Lebanon, aiding in

transport, and in the quarrying and hewing of stones, and sending a skilful Tyrian artist, another Hiram, to superintend the designing and graving of objects made of the precious metals, etc. For this assistance Solomon made a suitable recompense (1 K 5; 2 Ch 2). Excavations seem to show that a large part of the limestone of which the temple was built came from quarries in the immediate neighborhood of Jerus (Warren, *Underground Jerus.*, 60). The stones were cut, hewn and polished at the places whence they were taken, so that "there was neither hammer nor axe nor any tool of iron heard in the house, while it was in building" (1 K 5 17.18; 6 7). Opinions differ as to the style of architecture of the building. It was probably unique, but Phoen art also must have left its impress upon it (see *ARCHITECTURE*).

**II. The Temple Building.**—In contrast with the tabernacle, which was a portable "tent," consisting of a framework of acacia wood, with rich coverings hung over it, and standing in a "court" inclosed by curtains (see *TABERNACLE*), the

**1. In General** Temple was a substantial "house" built of stone (probably the hard white limestone of the district), with chambers in three stories, half the height of the building (1 K 6 5.6), round the sides and back, and, in front, a stately porch (1 K 6 3), before which stood two lofty bronze pillars—Jachin and Boaz (1 K 7 21; 2 Ch 3 4.15-17). Within, the house was lined with cedar, overlaid with gold, graven with figures of cherubim, palms, and open flowers (1 K 6 15.18.21.22.29), and a partition of cedar or stone divided the interior into two apartments—one the holy place (the *hēkhāl*), the other the most holy place, or "oracle" (*d'bhār*) (1 K 6 16-18). The floor was of stone, covered with fir (or cypress), likewise overlaid with gold (1 K 6 15.30). The platform on which the whole building stood was probably raised above the level of the court in front, and the building may have been approached by steps. Details are not given. The more particular description follows.

The Temple, like the tabernacle, stood facing E., environed by "courts" ("inner" and "greater"), which are dealt with below. Internally, the di-

mensions of the structure were, in length and width, double those of the tabernacle, viz. length 60 cubits, width 20 cubits. The height, however, was 30 cubits, thrice that of the tabernacle (1 K 6 2; cf vs 18.20). The precise length of the cubit is uncertain (see *CUBIT*); here, as in the art. *TABERNACLE*, it is taken as approximately 18 inches. In internal measurement, therefore, the Temple was approximately 90 ft. long, 30 ft. broad, and 45 ft. high. This allows nothing

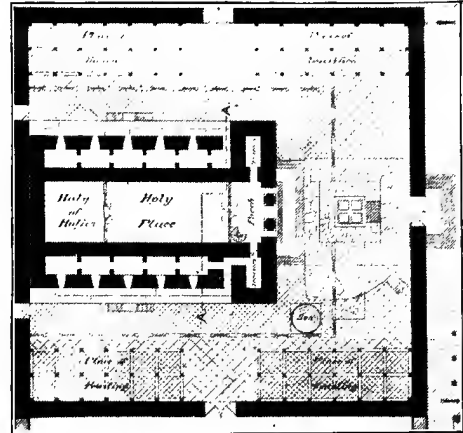

Plan of Solomon's Temple.

for the thickness of the partition between the two chambers. For the external measurement, the thickness of the walls and the width of the surrounding chambers and their walls require to be added. It cannot positively be affirmed that the dimensions of the Temple, including the porch, coincided precisely with those of Ezekiel's temple (cf Keil on 1 K 6 9.10); still, the proportions must have closely approximated, and may have been in agreement.

The walls of the building, as stated, were lined within with cedar; the holy place was ceiled with fir or cypress (2 Ch 3 5; the "oracle" perhaps with cedar); the flooring likewise was of fir (1 K 6 15). All was overlaid with gold, and walls and doors (see below) were adorned with gravings of cherubim, palm trees, and open flowers (1 K 6 19-35; 2 Ch 3 6 adds "precious stones"). Of the two chambers into which the house was divided, the outermost (or *hēkhāl*) was 40 cubits (60 ft.) long, and 20 cubits (30 ft.) wide (ver 17); the innermost (or *d'bhār*) was 20 cubits in length, breadth and height—a cube (ver 20). As the height of the Temple internally was 30 cubits, it is obvious that above the most holy place there was a vacant space 20 cubits long and 10 high. This apparently was utilized as a chamber or chambers for storage or other purposes. It has been held by some (Kurtz, Fergusson, etc) that the ceiling along the entire Temple was at the height of 20 cubits, with chambers above (cf the allusion to "upper chambers" in 1 Ch 28 11; 2 Ch 3 9); this, however, seems unwarranted (cf Bähr on 1 K 6 14-19; the "upper chambers" were "overlaid with gold," 2 Ch 3 9, which points to something nobler in character). The inner chamber was a place of "thick darkness" (1 K 8 12).

The thickness of the Temple walls is not given, but the analogy of Ezekiel's temple (Ezk 41) and what is told of the side-chambers render it probable that the thickness was not less than 6 cubits (9 ft.). Around the Temple, on its two

sides and at the back, were built chambers (*q̄lā'ōth*, lit. "ribs"), the construction of which is summarily described. They were built in three stories, each story 5 cubits in height (allowance must also be made for flooring and roofing), the lowest being 5 cubits in breadth, the next 6 cubits, and the highest 7 cubits. This is explained by the fact that the chambers were not to be built *into* the wall of the Temple, but were to rest on ledges or rebatements in the wall, each rebate a cubit in breadth, so that the wall became thinner, and the chambers broader, by a cubit, each stage in the ascent (1 K 6 5-10). The door admitting into these chambers was apparently in the middle of the right side of the house, and winding stairs led up to the second and third stories (ver 8). It is not stated how many chambers there were; Jos (*Ant*, VIII, iii, 2) gives the number as 30, which is the number in Ezekiel's temple (Ezk 41 6). The outer wall of the chambers, which in Ezk is 5 cubits thick (41 9), may have been the same here, though some make it less. It is a question whether the rebatements were in the Temple wall only, or were divided between it and the outer wall; the former seems the more probable opinion, as nothing is said of rebatements in the outer wall. Above the chambers on either side were "windows of fixed lattice-work" (ver 4), i.e. openings which could not be closed ("windows broad within and narrow without"). The purposes for which the chambers were constructed are not mentioned. They may have been used partly for storage, partly for the accommodation of those engaged in the service of the Temple (cf 1 Ch 9 27).

A conspicuous feature of the Temple was the porch in front of the building, with its twin pillars, Jachin and Boaz. Of the porch itself a very brief description is given. It

**4. The Porch and Pillars** is stated to have been 20 cubits broad—the width of the house—and 10 cubits deep (1 K 6 3). Its height is not given in 1 K, but it is said in 2 Ch 3 4 to have been 120 cubits, or approximately 180 ft. Some accept this enormous height (Ewald, Stanley, etc), but the majority more reasonably infer that there has been a corruption of the number. It may have been the same height as the Temple—30 cubits. It was apparently open in front, and, from what is said of its being "overlaid within with pure gold" (2 Ch 3 4), it may be concluded that it shared in the splendor of the main building, and had architectural features of its own which are not recorded. Some find here, in the wings, treasury chambers, and above, "upper chambers," but such restorations are wholly conjectural. It is otherwise with the monumental brass (bronze) pillars—Jachin and Boaz—of which a tolerably full description is preserved (1 K 7 15-22; 2 Ch 3 15-17; 4 11-13; cf Jer 52 20-23), still, however, leaving many points doubtful. The pillars which stood in front of the porch, detached from it, were hollow bronze castings, each 18 cubits (27 ft.) in height (35 cubits in 2 Ch 3 15 is an error), and 12 cubits (18 ft.) in circumference, and were surmounted by capitals 5 cubits (7½ ft.) high, richly ornamented on their lower, bowl-shaped (1 K 7 20.41.42) parts, with two rows of pomegranates, inclosing festoons of chain-work, and, in their upper parts, rising to the height of 4 cubits (6 ft.) in graceful lily-work (see JACHIN AND BOAZ).

It was seen that the holy place (*hēkhāl*) was divided from the most holy (*dōbhīr*) by a partition, probably of cedar wood, though some think of a stone wall, one or even two cubits thick. In this partition were folding doors, made of olive wood, with their lintels 4 cubits wide (1 K 6 31; some

interpret differently, and understand the upper part of the doorway to be a pentagon). The doors, like the walls, had carvings of cherubim, palm trees, and flowers, and the whole was gold-plated (ver 32). Behind the partition hung the sanctuary veil (2 Ch 3 14). At the entrance of the Temple, similarly, were folding doors, with their lintels 5 cubits in width, only this time the posts only were of olive, while the doors, divided into two leaves, were of fir (or cypress) wood (1 K 6 33-35). The carving and gold-plating were as on the inner doors, and all the doors had hinges of gold (1 K 7 50).

**III. Courts, Gates and Royal Buildings.**—The Temple was enclosed in "courts"—an "inner" (1 K 6 36; 7 12; 2 Ch 4 9, "court of the priests";

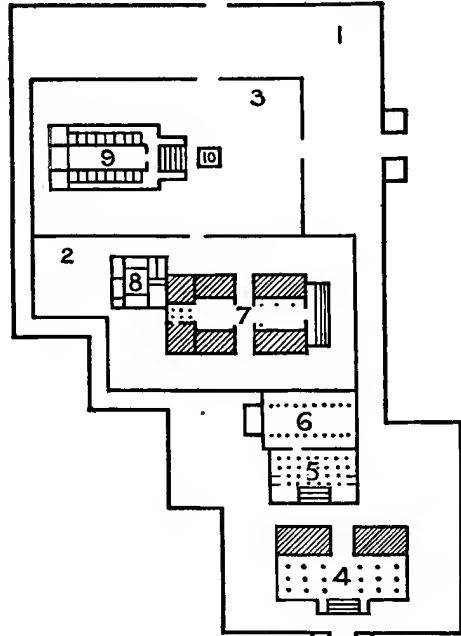

Great Court including Royal Buildings.

1. Great Court. 2. The "Other" or Middle Court. 3. The Inner (or Temple) Court. 4. House of Lebanon. 5. Porch of Pillars. 6. Throne Porch. 7. Royal Palace. 8. Harem. 9. Temple. 10. Altar.

Jer 36 10, "the upper court"; Ezk 8 3.16; 10 3), and an outer or "greater court" (1 K 7 9.12; 2 Ch 4 9)—regarding the situation, dimensions and relations of which, alike to one another and to the royal buildings described in 1 K 7, the scanty notices in the history leave room for great diversity of opinion (see COURT OF THE SANCTUARY).

The "inner court" (*hāçer ha-p'nāmūth*) is repeatedly referred to (see above). Its dimensions are not given, but they may be presumed to be twice those of the tabernacle Inner Court court, viz. 200 cubits (300 ft.) in length and 100 cubits (150 ft.) in breadth. The name in Jer 36 10, "the upper court," indicates that it was on a higher level than the "great court," and as the Temple was probably on a platform higher still, the whole would present a striking terraced aspect.

(1) *The walls* of the court were built of three rows of hewn stone, with a coping of cedar beams (1 K 6 36). Their height is not stated; it is doubtful if it would admit of the colonnades which some have supposed; but "chambers" are mentioned (Jer 35 4; 36 10—if, indeed, all belong to the

"inner" court), which imply a substantial structure. It was distinctively "the priests' court" (2 Ch 4 9); probably, in part, was reserved for them; to a certain degree, however, the laity had evidently free access into it (Jer 36 10; 38 14; Ezk 8 16, etc.). The mention of "the new court" (2 Ch 20 5, time of Jehoshaphat), and of "the two courts of the house of Jeh" (2 K 21 5; 2 Ch 33 5, time of Manasseh), suggests subsequent enlargement and division.

(2) Though *gates* are not mentioned in the narratives of the construction, later allusions show that there were several, though not all were of the time of Solomon. The principal entrance would, of course, be that toward the E. (see EAST GATE). In Jer 26 10 there is allusion to "the entry of the new gate of Jeh's house." This doubtless was "the upper gate" built by Jotham (2 K 15 35) and may reasonably be identified with the "gate that looketh toward the N." and the "gate of the altar" (i.e. through which the sacrifices were brought) in Ezk 8 3.5, and with "the upper gate of Benjamin" in Jer 20 3. Mention is also made of a "gate of the guard" which descended to the king's house (2 K 11 19; see below). Jeremiah speaks of a "third entry that is in the house of Jeh" (38 14), and of "three keepers of the threshold" (52 24), but it is not clear which court is intended.

The outer or "great court" of the Temple (*hāḥēz ha-g'dhōlāh*) opens up more difficult problems.

Some regard this court as extending to the E. in front of the "inner court"; others, as Keil, think of it as a great inclosure surrounding the "inner court" and stretching perhaps 150 cubits E. of the latter (cf his *Bib. Archaeology*, I, 170-71). These writers remove the court from all connection with the royal buildings of 1 K 7, and distinguish it from "the great court of 7 9.12." A quite different construction is that advocated by Stade and Benzinger, and adopted by most recent authorities (cf arts. on "Temple" in *HDB*, IV, in *EB*, IV, in one-vol *HDB*, in *DB* [Dalman]; G. A. Smith, *Jerus.*, II, 59 ff, etc.). The great court, on this view, not only surrounds the Temple, with its (inner) court, but, extending to the S., incloses the whole complex of the royal buildings of 1 K 7. This has the advantage of bringing together the references to the "great court" in 1 K 7 9.12 and the other references to the outer court. The court, thus conceived, must have been very large. The extensive part occupied by the royal buildings being on a lower level than the "inner court," entrance to it is thought to have been by "the gate of the guard unto the king's house" mentioned in 2 K 11 19. Its wall, like that of the inner court, was built in three courses of hewn stone, and one course of cedar (1 K 7 12). Its gates overlaid with brass (2 Ch 4 9, i.e., "bronze") show that the masonry must have been both high and substantial. On the "other court" of 1 K 7 8, see next paragraph.

The group of buildings which, on the theory now stated, were inclosed by the southern part of the great court, are those described in 1 K 7 1-12.

**3. The Royal Buildings** They were of hewn stone and cedar wood (vs 9-11), and embraced: (1) The king's house, or royal palace (ver 8), in close contiguity with the Temple-court (2 K 11 19). (2) Behind this to the W., the house of Pharaoh's daughter (ver 9)—the apartments of the women. Both of these were inclosed in a "court" of their own, styled in ver 8 "the other court," and in 2 K 20 4 m "the middle court." (3) S. of this stood the throne-room, and porch or hall of judgment, paneled in cedar "from floor to floor," i.e. from floor to ceiling (ver 7). The throne, we read later (1 K 10 18-20), was of ivory, overlaid with gold, and on either side of the throne, as well as of the six steps that led up to it, were lions. The hall served as an audience chamber, and for the administration of justice. (4) Yet farther S. stood the porch or hall of pillars, 50 cubits (75 ft.) long and 30 cubits (45 ft.)

broad, with a sub-porch of its own (ver 6). It is best regarded as a place of promenade and vestibule to the hall of judgment. (5) Lastly, there was the imposing and elaborate building known as "the house of the forest of Lebanon" (vs 2-5), which appears to have received this name from its multitude of cedar pillars. The scanty hints as to its internal arrangements have baffled the ingenuity of the commentators. The house was 100 cubits (150 ft.) in length, 50 cubits (75 ft.) in breadth, and 30 cubits (45 ft.) in height. Going round the sides and back there were apparently four rows of pillars (LXX has *three* rows), on which, supported by cedar beams, rested three tiers or stories of side-chambers (lit. "ribs," as in 6 5; cf RVm). In ver 3 it is disputed, whether the number "forty and five; fifteen in a row" (as the Heb may be read) refers to the pillars or to the chambers; if to the former, the LXX reading of "three rows" is preferable. The windows of the tiers faced each other on the opposite sides (vs 4.5). But the whole construction is obscure and doubtful. The spacious house was used partly as an armory; here Solomon put his 300 shields of beaten gold (10 17).

**IV. Furniture of the Temple.**—We treat here, first, of the sanctuary in its two divisions, then of the (inner) court.

(1) *The "d'bhūr."*—In the most holy place, or *d'bhūr*, of the sanctuary stood, as before, the old

**1. The Sanctuary** Mosaic ark of the covenant, with its two golden cherubim above the mercy-seat (see ARK OF THE COVENANT; TABERNACLE). Now, however, the symbolic element was increased by the ark being placed between two other figures of cherubim, made of olive wood, overlaid with gold, 10 cubits (15 ft.) high, their wings, each 5 cubits (7½ ft.) long, outstretched so that they reached from wall to wall of the oracle (20 cubits), the inner wings meeting in the center (1 K 6 23-28; 2 Ch 3 10-13). See CHERUBIM.

(2) *The "hēkhāl."*—In the holy place, or *hēkhāl*, the changes were greater. (a) Before the oracle, mentioned as belonging to it (1 K 6 22), stood the altar of incense, covered with cedar, and overlaid with gold (1 K 6 20.22; 7 48; 2 Ch 4 19; see ALTAR OF INCENSE). It is an arbitrary procedure of criticism to attempt to identify this altar with the table of shewbread. (b) Instead of one golden candlestick, as in the tabernacle, there were now 10, 5 placed on one side and 5 on the other, in front of the oracle. All, with their utensils, were of pure gold (1 K 7 49; 2 Ch 4 7). (c) Likewise, for one table of shewbread, there were now 10, 5 on one side, 5 on the other, also with their utensils made of gold (1 K 7 48, where, however, only one table is mentioned; 2 Ch 4 8, "100 basins of gold"). As these objects, only enlarged in number and dimensions, are fashioned after the model of those of the tabernacle, further particulars regarding them are not given here.

(1) *The altar.*—The most prominent object in the Temple-court was the altar of burnt offering,

**2. The Court (Inner)** or brazen altar (see BRAZEN ALTAR). The site of the altar, as already seen, was the rock *eš šakhrā*, where Araunah had his threshing-floor. The notion of some moderns that the rock itself was the altar, and that the brazen (bronze) altar was introduced later, is devoid of plausibility.

An altar is always something reared or built (cf 2 S 24 18.25). The dimensions of the altar, which are not mentioned in 1 K, are given in 2 Ch 4 1 as 20 cubits (30 ft.) long, 20 cubits (30 ft.) broad, and 10 cubits (15 ft.) high. As utensils connected with it—an incidental confirmation of its historicity—are pots, shovels, basins and fleshhooks (1 K 7 40.45; 2 Ch 4 11.16). It will be observed that the assumed halving proportions of the tabernacle are here quite departed from (cf Ex 27 1).

(2) *The molten (bronze) sea.*—A new feature in the sanctuary court—taking the place of the "laver" in the tabernacle—was the "molten sea," the name being given to it for its great size. It was

an immense basin of bronze, 5 cubits (7½ ft.) high, 10 cubits (15 ft.) in diameter at the brim, and 30 cubits (45 ft.) in circumference, resting on 12 bronze oxen, and placed between the altar and the Temple-porch, toward the S. (1 K 7 23-26.39; 2 Ch 4 2-5.10). The bronze was a handbreadth in thickness. The brim was shaped like the flower of a lily, and encompassing the basin were ornamental knobs. Its capacity is given as 2,000 baths (1 K 7 26; by error in 2 Ch 4 5, 3,000 baths). The oxen on which it rested faced the four cardinal points—three looking each way. The “sea,” like the laver, doubtless supplied the water for the washing of the priests’ hands and feet (cf Ex 30 18; 38 8). The view of certain scholars (Kosters, Gunkel, etc) that the “sea” is connected with Bab mythical ideas of the great deep is quite fanciful; no hint appears of such significance in any part of the narrative. The same applies to the lavers in the next paragraph.

(3) *The lavers and their bases.*—The tabernacle laver had its place taken by the “sea” just described, but the Temple was also provided with 10 lavers or basins, set on “bases” of elaborate design and moving upon wheels—the whole made of bronze (1 K 7 27-37). Their use seems to have been for the washing of sacrifices (2 Ch 4 6), for which purpose they were placed, 5 on the north side, and 5 on the south side, of the Temple-court. The bases were 4 cubits (6 ft.) long, 4 cubits broad, and 3 cubits (4½ ft.) high. These bases were of the nature of square paneled boxes, their sides being ornamented with figures of lions, oxen and cherubim, with wreathed work beneath. They had four feet, to which wheels were attached. The basin rested on a rounded pedestal, a cubit high, with an opening 1½ cubits in diameter to receive the laver (1 K 7 31). Mythological ideas, as just said, are here out of place.

**V. History of the Temple.**—The Temple was founded in the 4th year of Solomon’s reign (1 K 6

1), and occupied 7½ years in building (6 38); the royal buildings occupied and Dedicated 13 years (7 1)—20 years in all (the two periods, however, may in part synchronize). On the completion of the

Temple, the ark was brought up, in the presence of a vast assemblage, from Zion, and, with innumerable sacrifices and thanksgiving, was solemnly deposited in the Holy of Holies (1 K 8 1-21; 2 Ch 5; 6 1-11). The Temple itself was then dedicated by Solomon in the noble prayer recorded in 1 K 8 22-61; 2 Ch 6 12-42, followed by lavish sacrifices, and a 14 days’ feast. At its inauguration the house was filled with the “glory” of Jeh (1 K 8 10. 11; 2 Ch 5 13.14).

The religious declension of the later days of Solomon (1 K 11 1-8) brought in its train disasters for the nation and the Temple.

**2. Repeated Plunderings.** On Solomon’s death the kingdom was disrupted, and the Temple ceased to be the one national sanctuary. It had its rivals in the calf-shrines set up by Jeroboam at Beth-el and Dan (1 K 12 25-33). In the 5th year of Rehoboam an expedition was made against Judah by Shishak, king of Egypt, who, coming to Jerus, carried away the treasures of the Temple, together with those of the king’s house, including the 300 shields of gold which Solomon had made (1 K 14 25-28; 2 Ch 12 2-9). Rehoboam’s wife, Maacah, was an idolatress, and during the reign of Abijam, her son, introduced many abominations into the worship of the Temple (1 K 15 2.12.13). Asa cleared these away, but himself further depleted the Temple and royal treasuries by sending all that was left of their silver and gold to Ben-hadad, king of Syria, to buy his help against Baasha, king

of Israel (1 K 15 18.19). Again the Temple was foully desecrated by Athaliah (2 Ch 24 7), necessitating the repairs of Jehoash (2 K 12 4 ff; 2 Ch 24 4 ff); and a new plundering took place in the reign of Ahaziah, when Jehoash of Israel carried off all the gold and silver in the Temple and palace (2 K 14 14). Uzziah was smitten with leprosy for presuming to enter the holy place to offer incense (2 Ch 26 16-20). Jehoshaphat, earlier, is thought to have enlarged the court (2 Ch 20 5), and Jotham built a new gate (2 K 15 35; 2 Ch 27 3). The ungodly Ahaz went farther than any of his predecessors in sacrilege, for, besides robbing the Temple and palace of their treasures to secure the aid of the king of Assyria (2 K 16 8), he removed the brazen altar from its time-honored site, and set up a heathen altar in its place, removing likewise the bases and ornaments of the lavers, and the oxen from under the brazen (bronze) sea (2 K 16 10-17).

An earnest attempt at reform of religion was made by Hezekiah (2 K 18 1-6; 2 Ch 29 31), but even

he was driven to take all the gold and silver in the Temple and king’s house at Reform to meet the tribute imposed on him by Sennacherib, stripping from the doors and pillars the gold with which he himself had overlaid them (2 K 18 14-16; 2 Ch 32 31). Things became worse than ever under Manasseh, who reared idolatrous altars in the Temple-courts, made an Asherah, introduced the worship of the host of heaven, had horses dedicated to the sun in the Temple-court, and connived at the worst pollutions of heathenism in the sanctuary (2 K 21 3-7; 23 7.11). Then came the more energetic reforms of the reign of Josiah, when, during the repairs of the Temple, the discovery was made of the Book of the Law, which led to a new covenant with Jeh, a suppression of the high places, and the thorough cleansing-out of abuses from the Temple (2 K 22; 23 1-25; 2 Ch 34; 35). Still, the heart of the people was not changed, and, as seen in the history, and in the pages of the Prophets, after Josiah’s death, the old evils were soon back in full force (cf e.g. Ezk 8 7-18).

The end, however, was now at hand. Nebuchadnezzar made Jehoiakim his tributary; then, on his rebelling, came, in the reign of

**4. Final Overthrow.** Jehoiachin, took Jerus, carried off the treasures of the Temple and palace, with the gold of the Temple vessels (part had already been taken on his first approach, 2 Ch 36 7), and led into captivity the king, his household and the chief part of the population (2 K 24 1-17). Eleven years later (586 BC), after a siege of 18 months, consequent on Zedekiah’s rebellion (2 K 25 1), the Bab army completed the destruction of Jerus and the Temple. Only a few lesser utensils of value, and the brazen (bronze) pillars, bases and sea remained; these were now taken away, the larger objects being broken up (2 K 25 13-16). The Temple itself, with its connected buildings, and the houses in Jerus generally, were set on fire (ver 9). The ark doubtless perished in the conflagration, and is no more heard of. The residue of the population—all but the poorest—were carried away captive (vs 11.12; see CAPTIVITY). Thus ended the first Temple, after about 400 years of chequered existence.

II. EZEKIEL’S PROPHETIC SKETCH

**I. Introductory.**—Wellhausen has said that chs 40-48 of Ezk “are the most important in his book, and have been, not incorrectly, called the key to the OT” (*Prolegomena*, E.T, 167). He means that Ezekiel’s legislation represents the first draft, or sketch, of a priestly code, and that subsequently,



on its basis, men of the priestly school formulated the PC as we have it. Without accepting this view, dealt with elsewhere, it is to be admitted that Ezekiel's sketch of a restored temple in chs 40-43 has important bearings on the history of the Temple, alike in the fact that it presupposes and sheds back light upon the structure and arrangements of the first Temple (Solomon's), and that in important respects it forecasts the plans of the second (Zerubbabel's) and of Herod's temples.

While, however, there is this historical relation, it is to be observed that Ezekiel's temple-sketch is unique, presenting features not found in any of the actually built temples.

**2. Conception Unique and Ideal** The temple is, in truth, an ideal construction never intended to be literally realized by returned exiles, or any other body of people. Visionary in origin, the ideas embodied, and not the actual construction, are the main things to the prophet's mind. It gives Ezekiel's conception of what a perfectly restored temple and the service of Jeh would be under conditions which could scarcely be thought of as ever likely literally to arise. A literal construction, one may say, was impossible. The site of the temple is not the old Zion, but "a very high mountain" (40 2), occupying indeed the place of Zion, but entirely altered in elevation, configuration and general character. The temple is part of a scheme of a transformed land, partitioned in parallel tracts among the restored 12 tribes (47 13-48 7.23-29), with a large area in the center, likewise stretching across the whole country, hallowed to Jeh and His service (48 8-22). Supernatural features, as that of the flowing stream from the temple in ch 47, abound. It is unreasonable to suppose that the prophet looked for such changes—some of them quite obviously symbolical—as actually impending.

The visionary character of the temple has the effect of securing that its measurements are perfectly symmetrical. The cubit used is defined as "a cubit and a handbreadth" (40 5), the contrast being with one or more smaller cubits (see CUBIT). In the diversity of opinion as to the precise length of the cubit, it may be assumed here that it was the same sacred cubit employed in the tabernacle and first Temple, and may be treated, as before, as approximately equivalent to 18 inches.

**II. Plan of the Temple.**—Despite obscurities and corruption in the text of Ezk, the main outlines of the ideal temple can be made out without much difficulty (for details the comms. must be consulted; A. B. Davidson's "Ezekiel" in the *Cambridge Bible* series may be recommended; cf also Keil; a very lucid description is given in Skinner's "Book of Ezk," in the *Expositor's Bible*, 406-13; for a different view, see Caldecott, *The Second Temple in Jerus.*)

The temple was inclosed in two courts—an outer and an inner—quite different, however, in character and arrangement from those of the first Temple. The outer court, as shown by the separate measurements (cf Keil on 40 27), was a large square of 500 cubits (750 ft.), bounded by a wall 6 cubits (9 ft.) thick and 6 cubits high (40 5). The wall was pierced in the middle of its north, east and south sides by massive gateways, extending into the court to a distance of 50 cubits (75 ft.), with a width of 25 cubits (37½ ft.). On either side of the passage in these gateways were three guardrooms, each 6 cubits square (ver 7 m), and each gateway terminated in a "porch," 8 cubits (12 ft.) long (ver 9), and apparently (thus LXX, ver 14; the Heb text seems corrupt), 20 cubits across. The ascent to the gateways was by seven steps (ver 6; cf vs 22.26), showing that the level of the court was to this extent higher than the ground outside. Round the court, on the three sides named—its edge

in line with the ends of the gateways—was a "pavement," on which were built, against the wall, chambers, 30 in number (vs 17.18). At the four corners were inclosures (40 cubits by 30) where the sacrifices were cooked (cf 46 21-24)—a fact which suggests that the cells were mainly for purposes of feasting. (The "arches" [*elamim*] of vs 16.21, etc [RVm "colonnade"], if distinguished from the "porch" [*ulam*])—A. B. Davidson and others identify them—are still parts of the gateway—vs 21, etc.)

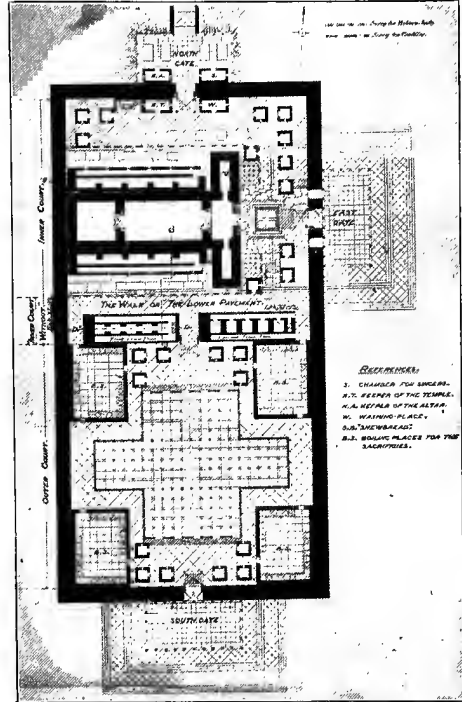

Ezekiel's Temple Plan.

The inner court was a square of 100 cubits (150 ft.), situated exactly in the center of the larger court (40 47).

**2. Inner Court** It, too, was surrounded by a wall, and had gateways, with guardrooms, etc, similar to those of the outer court, saving that the gateways projected outward (50 cubits), not inward. The gates of outer and inner courts were opposite to each other on the N., E., and S., a hundred cubits apart (vs 19.23.27; the whole space, therefore, from wall to wall was 50 and 100 and 50 = 200 cubits). The ascent to the gates in this case was by eight steps (ver 37), indicating another rise in level for the inner court. There were two chambers at the sides of the north and south gates respectively, one for Levites, the other for priests (vs 44-46; cf m); at the gates also (perhaps only at the north gate) were stone tables for slaughtering (vs 39-43). In the center of this inner court was the great altar of burnt offering (45 14-17)—a structure 18 cubits (27 ft.) square at the base, and rising in four stages (1, 2, 4, and 4 cubits high respectively, vs 14.15), till it formed a square of 12 cubits (18 ft.) at the top or hearth, with four horns at the corners (vs 15.16). Steps led up to it on the E. (ver 17). See ALTAR OF BURNED OFFERING.

The inner court was extended westward by a second square of 100 cubits, within which, on a platform elevated another 6 cubits (9 ft.), stood the temple proper and its connected buildings (41 8).

**3. Temple Building and Adjuncts** This platform or basement is shown by the measurements to be 60 cubits broad (N. and S.) and 105 cubits long (E. and W.)—5 cubits projecting into the eastern square. The ascent to the temple-porch was by 10 steps (40 49; LXX, RVm). The temple itself was a building consisting, like Solomon's, of three parts—a porch at the entrance, 20 cubits (30 ft.) broad by 12 cubits (18 ft.) deep (so, most, following LXX, as required by the other measurements); the holy place or *hēkkāl*, 40 cubits (60 ft.) long by 20 cubits (30 ft.) broad; and the most holy place, 20 cubits by 20 (40 48.49; 41 1-4); the measurements are internal. At the sides of the porch stood two pillars (40 49), corresponding to the Jachin and Boaz of the older Temple. The holy and the most

holy places were separated by a partition 2 cubits in thickness (41 3; so most interpret). The most holy place was empty; of the furniture of the holy place mention is made only of an altar of wood (ver 22; see ALTAR A, III, 7; B, III, 3). Walls and doors were ornamented with cherubim and palm trees (vs 18,25). The wall of the temple building was 6 cubits (9 ft.) in thickness (41 5), and on the north, south, and west sides, as in Solomon's Temple, there were side-chambers in three stories, 30 in number (41 6; in each story?), with an outer wall 5 cubits (7½ ft.) in thickness (ver 9). These chambers were, on the basement, 4 cubits broad; in the 2d and 3d stories, owing, as in the older Temple, to rebatements in the wall, perhaps 5 and 6 cubits broad respectively (vs 6,7; in Solomon's Temple the side-chambers were 5, 6, and 7 cubits, 1 K 6 6). These dimensions give a total external breadth to the house of 50 cubits (with a length of 100 cubits), leaving 5 cubits on either side and in the front as a passage round the edge of the platform on which the building stood (described as "that which was left") (vs 9,11). The western end, as far as the outer wall, was occupied, the whole breadth of the inner court, by a large building (ver 12); all but a passage of 20 cubits (30 ft.) between it and the temple, belonging to what is termed "the separate place" (*gizrah*, vs 12,13, etc.). The temple-platform being only 60 cubits broad, there remained a space of 20 cubits (30 ft.) on the north and south sides, running the entire length of the platform; this, continued round the back, formed the *gizrah*, or "separate place" just named. Beyond the *gizrah* for 50 cubits (75 ft.) were other chambers, apparently in two rows, the inner 100 cubits, the outer 50 cubits, long, with a walk of 10 cubits between (42 1-4; the passage, however, is obscure; some, as Keil, place the "walk" outside the chambers). These chambers were assigned to the priests for the eating of "the most holy things" (ver 13). See GALLERY.

Such, in general, was the sanctuary of the prophet's vision, the outer and inner courts of which, and, crowning all, the temple itself, rising in successive terraces, presented to his inner eye an imposing spectacle which, in labored description, he seeks to enable his readers likewise to visualize.

III. THE TEMPLE OF ZERUBBABEL

**I. Introductory.**—Forty-eight years after Nebuchadnezzar's destruction of the first Temple, the Bab empire came to an end (538 BC), and Persia became dominant under

**1. The Decree of Cyrus.** In the year following, Cyrus made a decree sanctioning the return of the Jews, and ordering the rebuilding of the Temple at Jerus (2 Ch 36 23; Ezr 1 1-4). He not only caused the sacred vessels of the old Temple to be restored, but levied a tax upon his western provinces to provide materials for the building, besides what was offered willingly (Ezr 1 6-11; 6 3 ff). The relatively small number of exiles who chose to return for this work (40,000) were led by Sheshbazzar, "the prince of Judah" (Ezr 1 11), whom some identify with Zerubbabel, likewise named "governor of Judah" (Hag 1 1). With these, if they were distinct, was associated Joshua the high priest (in Ezr and Neh called "Jeshua").

The first work of Joshua and Zerubbabel was the building of the altar on its old site in the 7th month of the return (Ezr 3 3 ff). Masons

**2. Founding of the Temple.** and carpenters were engaged for the building of the house, and the Phoenicians were requisitioned for cedar wood from Lebanon (ver 7). In the 2d year the foundations of the temple were laid with dignified ceremonial, amid rejoicing, and the weeping of the older men, who remembered the former house (vs 8-13).

The work soon met with opposition from the mixed population of Samaria, whose offer to join it had been refused; hostile representa-

**3. Opposition.** tions, which proved successful, were made to the Pers king; from which **Completion of the Work** about 15 years, till the 2d year of Darius Hystaspis (520 BC; Ezr 4).

On the other hand, the prophets Haggai and Zechariah stimulated the flagging zeal of the builders, and, new permission being obtained, the work was re-

sumed, and proceeded so rapidly that in 516 BC the temple was completed, and was dedicated with joy (Ezr 5, 6).

**II. The Temple Structure.**—Few details are available regarding this temple of Zerubbabel. It stood on the ancient site, and may have been influenced in parts of its plan by the descriptions of the temple in Ezk. The inferiority to the first Temple, alluded to in Ezr 3 12 and Hag 2 3, plainly cannot refer to its size, for its dimensions as specified in the decree of Cyrus, viz. 60 cubits in height, and 60 cubits in breadth (Ezr 6 3; there is no warrant for confining the 60 cubits of height to the porch only; cf Jos, *Ant*, XI, i), exceed considerably those of the Temple of Solomon (side-chambers are no doubt included in the breadth). The greater glory of the former Temple can only refer to adornment, and to the presence in it of objects wanting in the second. The Mish declares that the second temple lacked five things present in the first—the ark, the sacred fire, the *sh'khinah*, the Holy Spirit, and the Urim and Thummim (*Yomá*, xxi,2).

The temple was divided, like its predecessor, into a holy and a most holy place, doubtless in similar proportions. In 1 Macc 1 22 **2. Its Dimensions and Furniture** mention is made of the "veil" between the two places. The most holy place, as just said, was empty, save for a stone on which the high priest, on the great Day of Atonement, placed his censer (*Yomá*, v,2). The holy place had its old furniture, but on the simpler scale of the tabernacle—a golden altar of incense, a single table of shewbread, one 7-branched candlestick. These were taken away by Antiochus Epiphanes (1 Macc 1 21,22). At the cleansing of the sanctuary after its profanation by this prince, they were renewed by Judas Maccabaeus (1 Macc 4 41 ff). Judas pulled down also the old desecrated altar, and built a new one (vs 44 ff).

The second temple had two courts—an outer and an inner (1 Macc 4 38,48; 9 54; Jos, *Ant*, XIV, xvi,2)—planned apparently on the model of those in Ezk. A. K. S. Kennedy infers from the measurements in the *Haram* that "the area of the great court of the second temple, before it was enlarged by Herod on the S. and E., followed that of Ezekiel's outer court—that is, it measured 500 cubits each way with the sacred rock precisely in the center" (*Expos T*, XX, 182). The altar on this old *sakhrá* site—the first thing of all to be "set on its base" (Ezr 3 3)—is shown by 1 Macc 4 47 and a passage quoted by Jos from Hecataeus (*CAp*, I, xxii) to have been built of unhewn stones. Hecataeus gives its dimensions as a square of 20 cubits and 10 cubits in height. There seems to have been free access to this inner court till the time of Alexander Jannaeus (104-78 BC), who, pelted by the crowd as he sacrificed, fenced off the part of the court in front of the altar, so that no layman could come farther (Jos, *Ant*, XIII, xiii, 5). The courts were colonnaded (*Ant*, XI, iv, 7; XIV, xvi, 2), and, with the house, had numerous chambers (cf Neh 12 44; 13 4 ff, etc.).

**3. Its Courts, Altar, etc** A brief contemporary description of this Temple and its worship is given in *Aristeas*, 83-104. This writer's interest, however, was absorbed chiefly by the devices for carrying away the sacrificial blood and by the technique of the officiating priests.

The vicissitudes of this temple in its later history are vividly recorded in 1 Macc and in Jos. In **4. Later Fortunes** Ecclus 50 is given a glimpse of a certain Simon, son of Onias, who repaired the temple, and a striking picture is furnished of the magnificence of the worship in his time. The desecration and pillaging of the sanctuary by Antiochus, and its cleansing and restoration under Judas are alluded to above (see HASMONEANS; MACCABEANS). At length Judaea became an integral part of the Rom empire. In 66 BC Pompey, having taken the temple-hill, entered the most holy place, but kept

his hands off the temple-treasures (*Ant*, XIV, iv, 4). Some years later Crassus carried away everything of value he could find (*Ant*, XIV, vii, 1). The people revolted, but Rome remained victorious. This brings us to the time of Herod, who was nominated king of Judaea by Rome in 39 BC, but did not attain actual power until two years later.

#### IV. THE TEMPLE OF HEROD

**I. Introductory.**—Herod became king *de facto* by the capture of Jerus in 37 BC. Some years later he built the fortress Antonia  
**1. Initiation to the N. of the temple (before 31 BC).** of the Work Midway in his reign, assigning a religious motive for his purpose, he formed the project of rebuilding the temple itself on a grander scale (Jos gives conflicting dates; in *Ant*, XV, xi, 1, he says "in his 18th year"; in *BJ*, I, xxi, 1, he names his 15th year; the latter date, as Schürer suggests [*GJV*<sup>4</sup>, I, 369], may refer to the extensive preparations). To allay the distrust of his subjects, he undertook that the materials for the new building should be collected before the old was taken down; he likewise trained 1,000 priests to be masons and carpenters for work upon the sanctuary; 10,000 skilled workmen altogether were employed upon the task. The building was commenced in 20–19 BC. The *naos*, or temple proper, was finished in a year and a half, but it took 8 years to complete the courts and cloisters. The total erection occupied a much longer time (cf *Jn* 2 20, "Forty and six years," etc); indeed the work was not entirely completed till 64 AD—6 years before its destruction by the Romans.

Built of white marble, covered with heavy plates of gold in front and rising high above its marble-cloistered courts—themselves a succession of terraces—the temple, compared  
**2. Its Grandeur** by Jos to a snow-covered mountain (*BJ*, V, v, 6), was a conspicuous and dazzling object from every side. The general structure is succinctly described by G. A. Smith: "Herod's temple consisted of a house divided like its predecessor into the Holy of Holies, and the Holy Place; a porch; an immediate fore-court with an altar of burnt offering; a Court of Israel; in front of this a Court of Women; and round the whole of the preceding, a Court of the Gentiles" (*Jerus*, II, 502). On the "four courts," of Jos, *Cap*, II, viii.

The original authorities on Herod's temple are chiefly the descriptions in Jos (*Ant*, XV, xi, 3, 5; *BJ*, V, v, etc), and the tractate *Middōth* in the Mish.  
**3. Authorities** The data in these authorities, however, do not always agree. The most helpful modern descriptions, with plans, will be found, with differences in details, in Keil, *Bib. Archaeology*, I, 187 ff.; in Fergusson, *Temples of the Jews*; in the arts. "Temple" in *HDB* (T. Witton Davies) and *EB* (G. H. Box); in the important series of papers by A. R. S. Kennedy in *Expos T* (vol XX), "Some Problems of Herod's Temple" (cf his art. "Temple" in one-vol *DB*); in Sanday's *Sacred Sites of the Gospels* (Waterhouse); latterly in G. A. Smith, *Jerus*, II, 499 ff.

Differences of opinion continue as to the sacred cubit.  
 A. R. S. Kennedy thinks the cubit can be definitely fixed at 17.6 in. (*Expos T*, XX, 24 ff.); G. A. Smith reckons it at 20.67 in. (*Jerus*, II, 504); T. Witton Davies estimates it at about 18 in. (*HDB*, IV, 713), etc.  
 W. S. Caldecott takes the cubit of Jos and the *Middōth* to be 1½ ft. It will suffice in this sketch to treat the cubit, as before, as approximately equivalent to 18 in.

**II. The Temple and Its Courts.**—Jos states that the area of Herod's temple was double that of its predecessor (*BJ*, I, xxi, 1). The

**1. Temple Area—** Mish (*Mid.*, ii.2) gives the area as 500 cubits (roughly 750 ft.); Jos (*Ant*, XV, xi, 3) gives it as a stadium (about 600 Gr ft.); but neither measure is quite exact. It is generally agreed that on its east, west and south sides Herod's

area corresponded pretty nearly with the limits of the present *Haram* area (see JERUSALEM), but that it did not extend as far N. as the latter (Kennedy states the difference at about 26 as compared with 35 acres, and makes the whole perimeter to be about 1,420 yards, ut supra, 66). The shape was an irregular oblong, broader at the N. than at the S. The whole was surrounded by a strong wall, with several gates, the number and position of some of which are still matters of dispute. Jos mentions four gates on the W. (*Ant*, XV, xi, 5), the principal of which, named in *Mid.*, i.3, "the gate of Kiponos," was connected by a bridge across the Tyropœon with the city (where now is Wilson's Arch). The same authority speaks of two gates on the S. These are identified with the "Huldah" (mole) gates of the Mish—the present Double and Triple Gates—which, opening low down in the wall, slope up in tunnel fashion into the interior of the court. The Mish puts a gate also on the north and one on the east side. The latter may be represented by the modern Golden Gate—a Byzantine structure, now built up. This great court—known later as the "Court of the Gentiles," because open to everyone—was adorned with splendid porticos or cloisters. The colonnade on the south side—known as the Royal Porch—was specially magnificent. It consisted of four rows of monolithic marble columns—162 in all—with Corinthian capitals, forming three aisles, of which the middle was broader and double the height of the other two. The roofing was of carved cedar. The north, west, and east sides had only double colonnades. That on the east side was the "Solomon's Porch" of the NT (*Jn* 10 23; *Acts* 3 11; 5 19). There were also chambers for officials, and perhaps a place of meeting for the Sanhedrin (*bēth dān*) (Jos places this elsewhere). In the wide spaces of this court took place the buying and selling described in the Gospels (*Mt* 21 12 and ||s; *Jn* 2 13 ff).

(1) *Wall*, "hēl," "šōrēgh," gates.—In the upper or northerly part of this large area, on a much higher level, bounded likewise by a

**2. Inner Sanctuary Inclosure** wall, was a second or inner inclosure—the "sanctuary" in the stricter sense (Jos, *BJ*, V, v, 2)—comprising the court of the women, the court of Israel and the priests' court, with the temple itself (Jos, *Ant*, XV, xi, 5). The surrounding wall, according to Jos (*BJ*, V, v, 2), was 40 cubits high on the outside, and 25 on the inside—a difference of 15 cubits; its thickness was 5 cubits. Since, however, the inner courts were considerably higher than the court of the women, the difference in height may have been some cubits less in the latter than in the former (of the different measurements in Kennedy, ut supra, 182), a fact which may explain the difficulty felt as to the number of the steps in the ascent (see below). Round the wall without, at least on three sides (some except the W.), at a height of 12 (*Mid.*) or 14 (Jos) steps, was an embankment or terrace, known as the hēl (fortification), 10 cubits broad (*Mid.* says 6 cubits high), and inclosing the whole was a low balustrade or stone parapet (Jos says 3 cubits high) called the šōrēgh, to which were attached at intervals tablets with notices in Gr and Lat, prohibiting entry to foreigners on pain of death (see PARTITION, WALL OF). From within the šōrēgh ascent was made to the level of the hēl by the steps aforesaid, and five steps more led up to the gates (the reckoning is probably to the lower level of the women's court). Nine gates, with two-storied gatehouses "like towers" (Jos, *BJ*, V, v, 3), are mentioned, four on the N., four on the S., and one on the E.—the last probably to be identified, though this is still disputed (Waterhouse, etc), with the "Gate of Nicanor" (*Mid.*), or "Corinthian Gate" (Jos),

which is undoubtedly "the Beautiful Gate" of Acts 3 2.10 (see for identification, Kennedy, ut supra, 270). This principal gate received its names from being the gift of a wealthy Alexandrian Jew, Nicanor, and from its being made of Corinthian brass. It was of great size—50 cubits high and 40 cubits wide—and was richly adorned, its brass glittering like gold (*Mid.*, ii.3). See BEAUTIFUL GATE. The other gates were covered with gold and silver (*Jos*, *BJ*, V, v, 3).

(2) *Court of the women.*—The eastern gate, approached from the outside by 12 steps (*Mid.*, ii.3; Maimonides), admitted into the court of the women, so called because it was accessible to women as well as to men. Above its single colonnades were galleries reserved for the use of women. Its dimensions are given in the Mish as 135 cubits square (*Mid.*, ii.5), but this need not be precise. At its four corners were large roofless rooms for storage and other purposes. Near the pillars of the colonnades were 13 trumpet-shaped boxes for receiving the money-offerings of the people (cf the incident of the widow's mite, *Mk* 12 41 ff; *Lk* 21 1 ff); for which reason, and because this court seems to have been the place of deposit of the temple-treasures generally, it bore the name "treasury" (*gazophylakion*, *Jn* 8 20). See TREASURY.

(3) *The inner court.*—From the women's court, the ascent was made by 15 semicircular steps (*Mid.*, ii.5; on these steps the Levites chanted, and beneath them their instruments were kept) to the inner court, comprising, at different levels, the court of Israel and the court of the priests. Here, again, at the entrance, was a lofty, richly ornamented gate, which some, as said, prefer to regard as the Gate of Nicanor or Beautiful Gate. Probably, however, the view above taken, which places this gate at the outer entrance, is correct. The Mish gives the total dimensions of the inner court as 187 cubits long (E. to W.) and 135 cubits wide (*Mid.*, ii.6; v.1). Originally the court was one, but disturbances in the time of Alexander Jannaeus (104-78 BC) led, as formerly told, to the greater part being railed off for the exclusive use of the priests (*Jos*, *Ant*, XIII, xii, 5). In the Mish the name "court of the priests" is used in a restricted sense to denote the space—11 cubits—between the altar and "the court of Israel" (see the detailed measurements in *Mid.*, v.1). The latter—"the court of Israel"—2½ cubits lower than "the court of the priests," and separated from it by a pointed fence, was likewise a narrow strip of only 11 cubits (*Mid.*, ii.6; v.1). *Jos*, with more probability, carries the 11 cubits of the "court of Israel" round the whole of the temple-court (*BJ*, V, vi). Waterhouse (*Sacred Sites*, 112) thinks 11 cubits too small for a court of male Israelites, and supposes a much larger inclosure, but without warrant in the authorities (cf Kennedy, ut supra, 183; G. A. Smith, *Jerus*, II, 508 ff).

(4) *The altar, etc.*—In the priests' court the principal object was the great altar of burnt offering, situated on the old site—the *shakhrā*—immediately in front of the porch of the temple (at 22 cubits distance—the space "between the temple and the altar" of *Mt* 23 35). The altar, according to the Mish (*Mid.*, iii.1), was 32 cubits square, and, like Ezekiel's, rose in stages, each diminishing by a cubit: one of 1 cubit in height, three of 5 cubits, which, with deduction of another cubit for the priests to walk on, left a square of 24 cubits at the top. It had four horns. *Jos*, on the other hand, gives 50 cubits for the length and breadth, and 15 cubits for the height of the altar (*BJ*, V, v, 6)—his reckoning perhaps including a platform (a cubit high?) from which the height is taken (see ALTAR). The altar was built of unhewn stones, and had on the

S. a sloping ascent of like material, 32 cubits in length and 16 in width. Between temple and altar, toward the S., stood the "laver" for the priests. In the court, on the north side, were rings, hooks, and tables, for the slaughtering, flaying and suspending of the sacrificial victims.

(1) *House and porch.*—Yet another flight of 12 steps, occupying most of the space between the temple-porch and the altar, led up to the platform (6 cubits high) on which stood the temple itself. This magnificent structure, built, as said before, of blocks of white marble, richly ornamented with gold on front and sides, exceeded in dimensions and splendor all previous temples.

**3. The Temple Building**

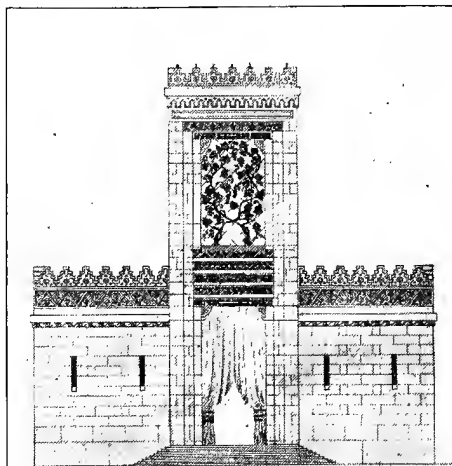

Front Elevation of Temple.

The numbers in the Mish and in *Jos* are in parts discrepant, but the general proportions can readily be made out. The building with its platform rose to the height of 100 cubits (150 ft.); the 120 cubits in *Jos*, *Ant*, XV, xi, 3, is a mistake; and was 60 cubits (90 ft.) wide. It was fronted by a porch of like height, but with wings extending 20 cubits (30 ft.) on each side of the temple, making the total breadth of the vestibule 100 cubits (150 ft.) also. The depth of the porch was 10 or 11 cubits; probably at the wings 20 cubits (*Jos*). The entrance, without doors, was 70 cubits high and 25 cubits wide (*Mid.* makes 40 cubits high and 20 wide). Above it Herod placed a golden eagle, which the Jews afterward pulled down (*Ant*, XVII, vi, 3). The porch was adorned with gold.

(2) "*Hēkhāl*" and "*d'bhār*."—Internally, the temple was divided, as before, into a holy place (*hēkhāl*) and a most holy (*d'bhār*)—the former measuring, as in Solomon's Temple, 40 cubits (60 ft.) in length, and 20 cubits (30 ft.) in breadth; the height, however, was double that of the older Temple—60 cubits (90 ft.); thus Keil, etc, following *Jos*, *BJ*, V, v, 5). *Mid.*, iv.6, makes the height only 40 cubits; A. R. S. Kennedy and G. A. Smith make the *d'bhār* a cube—20 cubits in height only. In the space that remained above the holy places, upper rooms (40 cubits) were erected. The holy place was separated from the holiest by a partition one cubit in thickness, before which hung an embroidered curtain or "veil"—that which was rent at the death of Jesus (*Mt* 27 51 and ||'s; *Mid.*, iv.7, makes two veils, with a space of a cubit between them). The Holy of Holies was empty; only a stone stood, as in the temple of Zerubbabel, on which the high priest placed his censer on the Day

of Atonement (Mish, *Yōmā'*, v.2). In the holy place were the altar of incense, the table of shewbread (N.), and the seven-branched golden candlestick (S.). Representations of the two latter are seen in the carvings on the Arch of Titus (see SHEWBREAD, TABLE OF; CANDLESTICK, GOLDEN). The spacious entrance to the holy place had folding doors, before which hung a richly variegated Bab curtain. Above the entrance was a golden vine with clusters as large as a man (Jos, *Ant*, XV, xi, 3; *BJ*, V, v, 4).

(3) *The side-chambers.*—The walls of the temple appear to have been 5 cubits thick, and against these, on the N., W., and S., were built, as in Solomon's Temple, side-chambers in three stories, 60 cubits in height, and 10 cubits in width (the figures, however, are uncertain), which, with the outer walls, made the entire breadth of the house 60 or 70 cubits. *Mid.*, iv.3, gives the number of the chambers as 38 in all. The roof, which Keil speaks of as "sloping" (*Bib. Archaeology*, I, 199), had gilded spikes to keep off the birds. A balustrade surrounded it 3 cubits high. Windows are not mentioned, but there would doubtless be openings for light into the holy place from above the side-chambers.

### III. NT Associations of Herod's Temple.—

Herod's temple figures so prominently in NT history that it is not necessary to do more than refer to some of the events of which it was the scene. It was here, before the incense altar, that the aged Zacharias had the vision which assured him that he should not die childless (Lk 1 11 ff). Here, in the women's court, or treasury, on the presentation by Mary, the infant Jesus was greeted by Simeon and Anna (Lk 2 27 ff). In His 12th year the boy Jesus amazed the temple rabbis by His understanding and answers (Lk 2 46 ff).

The chronological sequence of the Fourth Gospel depends very much upon the visits of Jesus to the temple at the great festivals (see **1. Earlier Incidents**).

**1. Earlier Incidents** which it was the scene. It was here, before the incense altar, that the aged Zacharias had the vision which assured him that he should not die childless (Lk 1 11 ff). Here, in the women's court, or treasury, on the presentation by Mary, the infant Jesus was greeted by Simeon and Anna (Lk 2 27 ff). In His 12th year the boy Jesus amazed the temple rabbis by His understanding and answers (Lk 2 46 ff).

The chronological sequence of the Fourth Gospel depends very much upon the visits of Jesus to the temple at the great festivals (see **2. Jesus in the Temple**).

**2. Jesus in the Temple** occurred the cleansing of the temple—court—the court of the Gentiles—from the dealers that profaned it (Jn 2 13 ff), an incident repeated at the close of the ministry (Mt 21 12 ff and ||'s). When the Jews, on the first occasion, demanded a sign, Jesus spoke of the temple of His body as being destroyed and raised up in three days (Jn 2 19), eliciting their retort, "Forty and six years was this temple in building," etc (ver 20). This may date the occurrence about 27 AD. At the second cleansing He not only drove out the buyers and sellers, but would not allow anyone to carry anything through this part of the temple (Mk 11 15-17). In Jn His zeal flamed out because it was His Father's house; in Mk, because it was a house of prayer for all nations (cf Isa 56 7). With this non-exclusiveness agrees the word of Jesus to the woman of Samaria: "The hour cometh, when neither in this mountain [in Samaria], nor in Jerus, shall ye worship the Father" (Jn 4 21). During the two years following His first visit, Jesus repeatedly, at festival times, walked in the temple-courts, and taught and disputed with the Jews. We find Him in Jn 5 at "a feast" (Passover or Purim?); in Jn 7, 8, at "the feast of tabernacles," where the temple-police were sent to apprehend Him (7 32, 45 ff), and where He taught "in the treasury" (8 20); in Jn 10 22 ff, at "the feast of the dedication" in winter, walking in "Solomon's Porch." His teaching on these occasions often started from some familiar temple scene—the libations of water carried by the priests to be poured upon the altar (Jn 7 37 ff), the proselytes (Greeks even) in the great portico (Jn 12 20 ff), etc. Of course Jesus,

not being of the priestly order, never entered the sanctuary; His teaching took place in the several courts open to laymen, generally in the "treasury" (see Jn 8 20).

The first days of the closing week of the life of Jesus—the week commencing with the Triumphal Entry—were spent largely in the temple. Here He spoke many parables (Mt 21, 22 and ||'s); here He delivered His tremendous arraignment of the Pharisees (Mt 23 and ||'s); here, as He "sat down over against the treasury," He beheld the people casting in their gifts, and praised the poor widow who cast in her two mites above all who cast in of their abundance (Mk 12 41 ff and ||'s). It was on the evening of His last day in the temple that His disciples drew His attention to "the goodly stones and offerings" (gifts for adornment) of the building (Lk 21 5 and ||'s) and heard from His lips the astonishing announcement that the days were coming—even in that generation—in which there should not be left one stone upon another (ver 6 and ||'s). The prediction was fulfilled to the letter in the destruction of the temple by the Romans in 70 AD.

Seven weeks after the crucifixion the Pentecost of Acts 2 was observed. The only place that fulfils the topographical conditions of the great gatherings is Solomon's Porch. The healing of the lame man (Acts 3 1 ff) took place at the "door . . . called Beautiful" of the temple, and the multitude after the healing ran together into "Solomon's Porch" or portico (ver 11). Where also were the words of Lk 24 53, they "were continually in the temple, blessing God," and after Pentecost (Acts 2 46), "day by day, continuing stedfastly . . . in the temple," etc, so likely to be fulfilled? For long the apostles continued the methods of their Master in daily teaching in the temple (Acts 4 1 ff). Many years later, when Paul visited Jerus for the last time, he was put in danger of his life from the myriads of Jewish converts "all zealous for the law" (Acts 21 20), who accused him of profaning the temple by bringing Greeks into its precincts, i.e. within the *šōrēgh* (vs 28-30). But Christianity had now begun to look farther afield than the temple. Stephen, and after him Saul, who became Paul, preached that "the Most High dwelleth not in houses made with hands" (Acts 7 48; 17 24), though Paul himself attended the temple for ceremonial and other purposes (Acts 21 26).

From the time that the temple ceased to exist, the Talm took its place in Jewish estimation; but it is in Christianity rather than in Judaism that the temple has a perpetual existence. The NT writers make no distinction between one temple and another. It is the idea rather than the building which is perpetuated in Christian teaching. The interweaving of temple associations with Christian thought and life runs through the whole NT. Jesus Himself supplied the germ for this development in the word He spoke concerning the temple of His body (Jn 2 19.21). Paul, notwithstanding all he had suffered from Jews and Jewish Christians, remained saturated with Jewish ideas and modes of thought. In one of his earliest Epp. he recognizes the "Jerus that is above" as "the mother of us all" (Gal 4 26 AV). In another, the "man of sin" is sitting "in the temple of God" (2 Thess 2 4). The collective church (1 Cor 3 16.17), but also the individual believer (1 Cor 6 19), is a temple. One notable passage shows how deep was the impression made upon Paul's mind by the incident connected with Trophimus the Ephesian (Acts 21 29). That "middle

wall of partition" which so nearly proved fatal to him then was no longer to be looked for in the Christian church (Eph 2 14), which was "a holy temple" in the Lord (ver 21). It is naturally in the Ep. to the He that we have the fullest exposition of ideas connected with the temple, although here the form of allusion is to the tabernacle rather than the temple (see TABERNACLE; cf Westcott on *Hebrews*, 233 ff). The sanctuary and all it included were but representations of heavenly things. Finally, in Rev, the vision is that of the heavenly temple itself (11 19). But the church—professing Christendom?—is a temple measured by God's command (11 1.2 ff). The climax is reached in 21 22-23: "I saw no temple therein [i.e. in the holy city]: for the Lord God the Almighty, and the Lamb, are the temple thereof . . . and the lamp thereof is the Lamb." Special ordinances are altogether superseded.

LITERATURE.—In general on the temples see Keil, *Bib. Archaeology*, I, in which the older lit. is mentioned; Fergusson, *Temples of the Jews*; Comms. on K, Ch, Ezr, Neh, and Ezk; arts. in the dict. and encs (*DB*, *HDB*, *EB*); G. A. Smith, *Jerus* and similar works. On Solomon's Temple, cf Benzinger, *Heb. Archæologie*. On Ezekiel's temple, see Skinner's "Book of Ezk" in *Expositor's Bible*. On Zerubbabel's temple, cf W. Shaw Caldecott, *The Second Temple in Jerus*. The original authorities on Herod's temple are chiefly Jos, *Ant.* XV, xi, and *BJ.* V, v; and the Mish, *Middoth*, II (this section of the *Middoth*, from Barclay's *Talm.*, may be seen in App. I of Fergusson's work above named). The Ger. lit. is very fully given in Schürer, *HJP.* I, 1, 438 ff (*GJV.* I, 392 f). See also the arts. of A. R. S. Kennedy in *Expos T.* XX, referred to above, and P. Waterhouse, in Sanday, *Sacred Sites of the Gospels*, 106 ff. On symbolism, cf Westcott, *Hebrews*, 233 ff. See also arts. in this Encyclopaedia on parts, furniture, and utensils of the temple, under their several headings.

W. SHAW CALDECOTT  
JAMES ORR

B. IN CRITICISM

- I. ALLEGED WANT OF HARMONY BETWEEN EARLIER (K) AND LATER (Ch) VERSIONS OF TEMPLE BUILDING
  - 1. Second Version Not a Facsimile of First
  - 2. The Two Versions Differ as to the Builder
  - 3. The Earlier Version Silent about Things Recorded in Later Version
- II. DETAILED OBJECTIONS AGAINST CHRONICLER'S ACCOUNT
  - 1. Reason for Interdicting David's Purpose to Build a Temple
  - 2. Impossibility of David in His Old Age Collecting Materials Enumerated by the Chronicler
  - 3. Supernaturally Received Pattern of the Temple Said to Have Been Given by David to Solomon
  - 4. Alleged Organization of the Temple-Service by David
  - 5. Assertion by Solomon That the Temple Would Be Used as a Central Sanctuary

LITERATURE

B. IN CRITICISM

Modern criticism does not challenge the existence of a Solomonic Temple on Mt. Moriah, as it does that of a Mosaic tabernacle in the wilderness. Only it maintains that historic value belongs exclusively to the narrative in K, while the statements in Ch are pure ornamentation or ecclesiastical trimming dating from post-exilic times. All that is true about the Temple, says criticism, is (1) that David originally, i.e. on coming to the throne of all Israel, contemplated erecting such a structure upon Araunah's threshing-floor, but was prohibited from doing so by Nathan, who at first approved of his design but was afterward directed by Jeh to stay the king's hand, and to inform the king that the work of building a house for Jeh to dwell in was not to be his (the king's) task and privilege but his son's, and that as a solatium for his disappointment Jeh would build him a house, by establishing the throne of his kingdom forever (2 S 7 4-17); (2) that after David's death Solomon called to mind the pious purpose of his father of which he had been informed and the express promise of Jeh that David's successor on the throne should execute that purpose, and accordingly resolved to "build a house for the name of Jeh his God" (1 K 5 3-5); and

(3) that 7½ years were employed in the work of construction, after which the finished Temple was dedicated in the presence of the congregation of Israel, with their princes, priests and Levites, in a speech which rehearsed the fact that David had intended to build the house but was prevented, and with a prayer which once more connected the Temple with the pious intention of David (1 K 8 18-20).

All the rest is simply embellishment (Wellhausen, *GT*, 181-92; art. "Temple" in *EB*): (1) that David's purpose to build the Temple was interdicted because he had been a man of war and had shed blood (1 Ch 23 3), which in Wellhausen's judgment should rather have been a qualification for the business; (2) that David in his old and feeble age made elaborate preparations for the construction of the house he was not to see—which, again writes Wellhausen, was like "making the bread so far ready that his son only required to shove it into the oven"; (3) that David gave to his son Solomon the pattern of the house in all its details as the Lord had caused him to understand in writing ("black upon white," as Wellhausen expresses it) by His (the Lord's) hand upon him—which was different from the way in which Moses received instruction about the tabernacle, viz. by a pattern shown to him in the Mount, and carried in his recollection; (4) that David before his death arranged all the musical service for the Temple, invented musical instruments, appointed all the officers to be associated with the Temple priests, Levites, porters and singers, distributing them in classes and assigning them their duties by lot (1 Ch 23 2-26; 2 Ch 8 12-16)—exactly as these things were afterward arranged in the second or post-exilic temple and were now carried back to David as the legislation of the PC was assigned to Moses; and (5) that David's son Solomon assures Hiram (RV "Huram") that the Temple will be used as a central sanctuary "to burn before him [Jeh] incense of sweet spices, and for the continual showbread, and for the burnt-offerings morning and evening, on the sabbaths, and on the new moons, and on the set feasts of Jeh our God" (2 Ch 2 3 ff), i.e. for Divine service, which, according to criticism, was of post-exilic origin.

The questions that now fall to be considered are: (1) whether the statements of the Chronicler are inconsistent with those in the Books of S and K; and (2) if not, whether they are in themselves such as to be incredible.

I. As to the Want of Harmony between the Earlier and Later Versions of the Temple Building.

It does not seem reasonable to hold that this has been established. The circumstance that the second account is not a facsimile of the first does not warrant the conclusion that the first alone is fact and the second fiction. It is quite conceivable that both might be true. David might have had it in his mind, as the first account states and the second acknowledges, to build a house for Jeh, and yet not have been able to carry his purpose into effect, and have been obliged to hand over its execution to his son. David, moreover, might have been hindered by Jeh (through His prophet Nathan) from building the Temple for more reasons than one—because the proposal was premature, God having it in His mind to build a house for David, i.e. to establish his dynasty, before requiring a permanent habitation for Himself; and also because the time was unpropitious, David having still much to do in the subjugation of his country's enemies; and because it was more fitting that a temple for the God of Peace should not be erected by one who had been a man of war from his youth. The first of these reasons is stated in S, the second and third are recorded in Ch.

The earlier version does not say that David built the house, but that his son was to do it, and this the later version does not contradict; the later version does not claim that the idea originated with Solomon, but ascribes it to David, precisely as the earlier version does. In this there is no disharmony, but rather underlying harmony. Both versions assert that David purposed and that Solomon performed, in which surely there is perfect agreement.

The silence of the earlier version about the things recorded in the later version, such as the preparation of material and the organization of the Temple-service, does not prove that these things were not known to the author of the earlier version, or had not taken place when he wrote. No writer is obliged to cram into his pages all he knows, but only to insert as much of his information as will subserve his aim in writing. Nor does his omission to set down in his narrative this or that particular fact or incident amount to a demonstration that the unrecorded fact or incident had not then occurred or was not within his cognizance. Least of all is it expected that a writer of civil history shall fill his pages with details that are purely or chiefly ecclesiastical. In short, if the omission from K of David's preparations and arrangements for the Temple testifies that no such preparations or arrangements were made, the omission from Ch of David's sin with Bath-sheba and of Nathan's parable of the Ewe Lamb should certify that either these things never happened or they were not known after the exile. It is usual to say they were purposely left out because it was the Chronicler's intention to encircle David with a nimbus of glory (Wellhausen), but this is simply critical hypothesis, the truth of which is disputed. On critical principles either these incidents in David's life were not true or the Chronicler was not aware of them. But the Chronicler had as one main source for his composition "the earlier historical books from Gen to K" (Driver), and "the tradition of the older source only has historical value" (Wellhausen).

**II. Detailed Objections against the Chronicler's Account.**—Examining now in detail the above-stated objections, we readily see that they are by no means so formidable as at first sight they look, and certainly do not prove the Chronicler's account to be incredible.

That David's purpose to build a temple should have been interdicted because he had been a man of war and had shed blood appears

**1. Inter-diction of David** to Wellhausen to be a watermark of non-historicity. Benzinger in *EB* (art. "Temple") goes beyond this and says:

"There is no historical probability that David had thoughts of building a temple." But if David never thought of building a temple, then not only was the Chronicler mistaken in making Solomon say (2 Ch 6 7) that it was in the heart of his father so to do, but he was chargeable with something worse in making the Lord say to David, "Whereas it was in thy heart to build a house for my name, thou didst well in that it was in thy heart" (2 Ch 6 8), unless he was absolutely certain that the statement was true—which it was not if Benzinger may be relied on.

Nor is it merely the Chronicler whose character for intelligence and piety suffers, if David never thought of building a temple; the reputation of the author or authors of S and K must also go, since they both declare that David did entertain the purpose which Benzinger denies (2 S 7 2; 1 K 5 3); and an impartial reasoner will hesitate before he sacrifices the good name even of two unknown ancient writers at the *ipse dixit* of any modern scholar.

We may therefore limit our remarks to Wellhausen's objection and reply that the reason assigned by Ch for prohibiting David from carrying out his purpose, viz. that he had been a man of war, might have been an argument for permitting him to do so, or at least for his seeking to do so, had his object been to erect a monument to his own glory or a thank offering to God for the victories he had won; but not if the Temple was designed to be a habitation

wherein God might dwell among His people to receive their worship and bless them with His grace. Strange as it may seem (Winer) that David should have been debarred from carrying out his purpose for the reason assigned, yet there was reason in the interdict, for not only was it fitting that peaceful works should be carried out by peaceful hands (Merz in *PRB*), but David's vocation was not temple-building but empire-building (to use a modern phrase); and many campaigns lay before him ere the leisure could be found or the land could be ready for the execution of his sacred design.

That David in his old and feeble age could not possibly have collected all the materials enumerated by 1 Ch 29 might possibly have been true, had David been an impecunious of Materials chieftain and had he only in the last years of his life commenced to amass treasure. But David was a powerful and wealthy eastern potentate and a valiant warrior besides, who had conquered numerous tribes, Philis, Moabites, Syrians, Edomites and Ammonites, and had acquired from his victories large spoil, which from an early stage in his career he had been accustomed to dedicate to the Lord (2 S 8 11). Hence it is little better than trifling to put forward as an inherent mark of incredibility the statement that David in his old age could not have made extensive and costly preparations for the building of the Temple—all the more that according to the narrative he was assisted by "the princes of the fathers' houses, and the princes of the tribes of Israel, and the captains of thousands and of hundreds, with the rulers over the king's work," and "the people" generally, who all "offered willingly for the service of the house of God."

No doubt the value in sterling money of these preparations is enormous—the gold and silver alone being variously reckoned at 8 (Keil), 16 (Bertheau), 81 (Michaelis), 450 (Kantzschn), 1,400 (Rawlinson) millions of pounds—and might reasonably suggest either that the text has become corrupt, or the numbers were originally used loosely to express the idea of an extraordinary amount, or were of set purpose exaggerated. The first of these explanations is adopted by Rawlinson; the second by Bertheau; the third by Wellhausen, who sees in the whole section (1 Ch 22–29) "a frightful example of the statistical phantasy of the Jews, which delights itself in immense sums of gold upon paper." But even conceding that in each of these explanations a measure of truth may lie, it does not seem justifiable to wipe out as unhistorical and imaginary the main statement of the Chronicler, that David's preparations were both extensive and costly, all the less that 1 K 10 14, 15 bears witness to the extraordinary wealth of Solomon, whose income is stated to have been 666 talents of gold, or about 3 millions sterling, a year, besides that he had of the merchantmen, and of the traffic of the spice merchants, and of all the kings of Arabia and of the governors of the country. If David's annual income was anything like this, and if he had command of all the treasures accumulated in previous years, it does not look so impossible as criticism would make out that David could have prepared for the future Temple as the Chronicler reports.

That David gave to Solomon the pattern of the Temple in a writing which had been prepared by him under direct supernatural guid-

**3. Plan of the Temple** who deny the possibility of such Divine communications being made by God to man. If criticism admits, as it sometimes does, the possibility of both revelation and inspiration, the objection under consideration must fall to the ground. That the method of making David acquainted with the pattern of the Temple was not in all respects the same as that adopted for showing Moses the model of the tabernacle, only proves that the resources of infinite wisdom are not usually exhausted by one effort, and that God is not necessarily tied down to one particular way of uttering His thoughts.

But criticism mostly rejects the idea of the supernatural and accordingly dismisses this statement

about the God-given pattern as altogether fanciful—pointing (1) to the fact that similar temples already existed among the Canaanites, as e.g. at Shechem (Jgs 9 46) and at Gaza (Jgs 16 29), which showed there was no special need for a Divinely prepared plan; and (2) to the circumstance that Solomon fetched Hiram, a Tyrian worker in brass, to assist in the erection of the Temple, which again, it is urged, renders probable the conclusion that at least Phoen ideas entered into its structure (Duncker, Benzinger). Suppose, however, it were true that the Temple was fashioned on a Phoen, Can. or Egypt model, that would not disprove the statement that David was guided by Divine inspiration in drawing up the outline of the building.

That David's organization of the Temple-service, both as to officers and instruments, as to ritual and music, corresponded exactly (or nearly so) with what afterward existed in the second temple can hardly be adduced as a proof of non-historicity, except on the supposition that Ch deliberately "transformed the old history into church history" by ascribing to David "the holy music and the arrangement of the Temple personals" which belonged to the post-exilic age, precisely as the author or authors of the PC, which dated from the same age (according to criticism), attributed this to Moses (Wellhausen, *GT*, 187)—in other words, by stating what was not true in either case, by representing that as having happened which had not happened. Whether this was originally intended to deceive and was a wilful fraud, as some hold, and whether it was legitimate then "to do evil that good might come," to persuade men that David organized the musical service which was performed in the second temple in order to secure for it popular acceptance, it may be left to each reader to determine; it must always be wrong to ascribe doubtful practices to good men like the authors of the PC and of Ch unless one is absolutely sure that they were guilty of such practices. Undoubtedly the fair and reasonable thing is to hold that the Chronicler wrote the truth until it is proved that he did not; and for his statement it may be claimed that at least it has this in its favor, that in the earlier sources David is distinctly stated to have been a musician (1 S 16 23), to have composed a song, Ps 18 (2 S 22 1), and to have been designated "the sweet psalmist of Israel." No doubt on the critical hypothesis this might explain why the thought occurred to the Chronicler to credit David with the organization of the Temple-service; but without the critical hypothesis it equally accounts for the interest David took in preparing "the music and the personals" for the Temple which his son was to build. "The tradition that David intended to build a temple and that he reorganized public worship, not forgetting the musical side thereof (cf 2 S 6 5 with Am 6 5)," says Kittel (*The Scientific Study of the OT*, 136, ET), "is not altogether without foundation."

That the Temple-service was carried out in accordance with the regulations of the PC does not prove that the Ch account is unreliable, unless it is certain that the post-exilic PC was an entirely new ritual which had never existed before, which some modern critics do not admit.

But, if it was merely, as some maintain, a codification of a cultus that existed before, then no sufficient reason exists for holding that Solomon's Temple was designed to be a private chapel for the king (Benzinger), erected partly out of piety but partly also out of love of splendor and statecraft (Reuss), rather than a central sanctuary for the people. A study of Solomon's letter to Hiram (2 Ch 2 4) shows that the Temple was intended for the concentration of the nation's sacrificial worship which had up till then been frequently offered at local shrines, though originally meant for celebration at the Mosaic tabernacle—for the burning of sweet incense (Ex 30 1), the offering day by day continually of the burnt offering (Ex 29 39). And though, it is admitted, the letter to Hiram as reported in 1 K makes no mention of this intention, yet it is clear from 1 K 8 62-65, that Solomon, after dedicating the Temple by prayer, used it for this purpose. Wherefore, if Ch simply transferred to the consecration of the Temple a ritual that had no existence till after the

exile, the author of K did the same, which again would destroy Wellhausen's admission that historical validity attaches to the earlier source. A much more likely supposition is that the ritual reported by both historians was not that of a PC manufactured for the second temple, but that which had been published by Moses for the tabernacle, in place of which it had come. That local shrines for many years existed alongside of the Temple only proves that Solomon's original idea was not perfectly carried out either by himself or his people.

LITERATURE.—The Comms. of Bertheau and Keil on Ch; Reuss, *Geschichte der heiligen Schriften des Alten Testaments*; arts. on "Temple" in Sch-Herz; Riehm, *Handwörterbuch*; HDB; EB; Wellhausen, *Prolegomena zur Geschichte Israels*.

T. WHITELAW

TEMPLE KEEPERS (SERVANTS): After the conquest of Midian, "Moses took one drawn out of every fifty, both of man and of beast, and gave them unto the Levites, that kept the charge of the tabernacle of Jeh" (Nu 31 47; cf ver 30). Similarly, after the deception of Joshua by the Gibeonites, "Joshua made them that day hewers of wood and drawers of water for the congregation, and for the altar of Jeh, unto this day" (Josh 9 27). The object of these notices, evidently, is to explain how a non-Israelitish class of sanctuary servants had taken their origin. Their existence at the time of Ezekiel, however, is the object of one of the latter's severest denunciations: "Ye have brought in foreigners, uncircumcised in heart and uncircumcised in flesh, to be in my sanctuary, to profane it. . . . And ye have not kept the charge of my holy things; but ye have set keepers of my charge in my sanctuary for yourselves" (Ezk 44 7 f). In place of these servants or "keepers" Ezekiel directs that such Levites are to be employed as have been degraded from priestly privileges for participating in idolatrous worship. On them shall devolve all the various duties of the temple except the actual offering of sacrifices, which is reserved for "the priests the Levites, the sons of Zadok" (44 10-15). For the use of this deposed class, "the priests, the keepers of the charge of the house," is reserved a special room in the inner court of the temple (40 44 f). See, further, NETHINIM. BURTON SCOTT EASTON

TEMPLES, tem'p'lz (תִּקְוֹת, *raḳkēh*, "thinness," "upper cheeks"): The original signifies the thinnest part of the skull (Jgs 4 21.22; 5 26). In Cant 4 3; 6 7, the bride's cheeks are likened to pomegranates because of the rich coloring of a slice of this fruit.

TEMPLES, ROBBERS OF (ἱερόσυλοι, *hierósuloi*; AV "robbers of churches," Acts 19 37): To explain this as "sacrilegious persons" is irreconcilable with the contrast in Rom 2 22. In Dt 7 25, the Jews were commanded entirely to destroy the gold and silver idols, ornaments of the heathen temples. The sin reproved is that of making that a matter of gain which, without regard to its value, they should have destroyed. "Dost thou, who regardest the mere touch of an idol as a horrible defilement, presume to rob their temples?" There is abundant evidence to show that this crime was not unusual. When the town-clerk of Ephesus declares the companions of Paul innocent of such charge, his words imply that the fact that they were Jews rendered them liable to such suspicion. So Jos goes out of his way (*Ant*, IV, viii, 10) to deny that Jews ever committed the crime.

H. E. JACOBS

TEMPT, temt, TEMPTATION, tem-tā'shun (נִסְּוֹת, *nāsāh*, "to prove," "try," "tempt," נִסְּוֹת, *maššāh*, "a trial," "temptation"; *πειράζω*, *peirázō*,



"to try," "prove," *πειρασμός, peirasμός*, "a trial," "proof"): The words have a sinister connotation in present-day usage which has not always attached to them. Originally the words were of neutral content, with the sense of "putting to the proof," the testing of character or quality. Thus God is "tempted" by Israel's distrust of Him, as if the people were actually challenging Him to show His perfections (Ex 17 2; Ps 78 18; Acts 15 10; He 3 9, and often); Abraham is "tempted," being called upon to offer up Isaac (Gen 22 1); and Jesus is "tempted" to a spectacular Messiahship (Mt 4 and || passages [see TEMPTATION OF CHRIST]). No evil is implied in the subject of these temptations. Temptation therefore in the Scripture sense has possibilities of holiness as well as of sin. For as all experience witnesses, it is one thing to be tempted, another thing to fall. To be tempted—one may rejoice in that (Jas 1 2), since in temptation, by conquering it, one may achieve a higher and nobler manhood.

"Why comes temptation but for man to meet  
And master and make crouch beneath his foot,  
And so be pedestalled in triumph?"

Holiness in its best estate is possible only under conditions which make it necessary to meet, resist and triumph over temptation. Thus Jesus Himself became our Great High Priest in that, being tempted in all points like as we are, He never once yielded, but fought and triumphed (He 4 15).

One must not deceive one's self, however, in thinking that, because by the grace of God one may have profit of virtue through temptation as an instrument, all temptation is equally innocent and virtuous. It is noticeable in the case of Jesus that His temptation was under the direction of the Spirit (Mk 1 12); He Himself did not seek it, nor did He fear it. Temptations encountered in this way, the way of duty, the way of the Spirit, alone constitute the true challenge of saintship (Jas 1 12); but it is the mark of an ignoble nature to be perpetually the center of vicious fancies and tempers which are not of God but of the devil (Jas 1 13-15). One may not escape entirely such buffetings of faith, but by any sound nature they are easily disposed of. Not so easily disposed of are the trials (temptations) to faith through adversity, affliction, trouble (Lk 22 28; Acts 20 19; Jas 1 2; 1 Pet 1 6); and yet there is no lack of evidence to the consoling fact that God does not suffer His own to be tempted above what they are able to bear (1 Cor 10 13) and that for every crisis His grace will be sufficient (2 Cor 12 8,9).

CHARLES M. STUART

**TEMPTATION OF CHRIST:** The sources for this event are Mk 1 12,13; Mt 4 1-11; Lk 4 1-13; cf He 2 18; 4 15,16, and see

**1. The Sources** **GETHESEMANE.** Mk is probably a condensation; Mt and Lk have the same source, probably the discourses of Jesus. Mt is usually regarded as nearest the original, and its order is here followed.

The Temptation is put immediately after the Baptism by all the synoptists, and this is psychologically necessary, as we shall see.

**2. Time and Place** The place was the wilderness; it was "up" from the Jordan valley (Mt), and was on the way back to Galilee (Lk). The traditional site, Mt. Quarantana, is probably a good guess.

At His baptism, Jesus received from heaven the final confirmation of His thought that He was the Messiah. It was the greatest conception which ever entered a human mind and left it sane. Under the irresistible influence of the Spirit,

**3. Significance** He turned aside to seek out in silence and alone the

principles which should govern Him in His Messianic work. This was absolutely necessary to any wise prosecution of it. Without the slightest precedent Jesus must determine what a Messiah would do, how He would act. Radical critics agree that, if such a period of meditation and conflict were not recorded, it would have to be assumed. By this conflict, Jesus came to that clearness and decision which characterized His ministry throughout. It is easy to see how this determination of guiding principles involved the severest temptation, and it is noteworthy that all the temptation is represented as coming from without, and none from within. Here too He must take His stand with reference to all the current ideas about the Messiah and His work.

Jesus alone can be the original reporter. To this Holtzmann and J. Weiss agree. The report was given for the sake of the disciples, for

**4. The Reporter** the principles wrought out in this conflict are the guiding principles in the whole work of the kingdom of God on earth.

(1) *Fasting.*—Jesus was so intensely absorbed that He forgot to eat. There was nothing ascetic or ritualistic about it, and so this is no example for ascetic fasting for us. It is doubtful whether the text demands absolute abstinence from food; rather, long periods of fasting, and insufficient food when He had it. At the end of the forty days, He woke to the realization that He was a starving man.

(2) *The first temptation* is not a temptation to doubt His Messiahship, nor is the second either. "If thou art the Son of God," i.e. "the Messiah," means, simply, "since thou art the Son of God" (see Burton, *Moods and Tenses*, secs. 244, 245; Robertson, *Short Grammar*, 161). There was not the slightest doubt on this point in Jesus' mind after the baptism, and Satan knew it. There is no temptation to prove Himself the Messiah, nor any hint of such a thing in Jesus' replies. The very point of it all is, How are you going to act, since you are Messiah? (Mt 4 3 || Lk 4 3).

The temptation has these elements: (a) The perfectly innocent craving for food is imperious in the starving man. (b) Why should He not satisfy His hunger, since He is the Son of God and has the power? Jesus replies from Dt 8 3, that God can and will provide Him bread in His own way and in His own time. He is not referring to spiritual food, which is not in question either here or in Dt (see Broadus' just and severe remark here). He does not understand how God will provide, but He will wait and trust. Divinely assured of Messiahship, He knows that God will not let Him perish. Here emerges the principle of His ministry; He will never use His supernatural power to help Himself. Objections based on Lk 4 30 and Jn 10 39 are worthless, as nothing miraculous is there implied. The walking on the water was to help the apostles' faith. But why would it have been wrong to have used His supernatural power for Himself? Because by so doing He would have refused to share the human lot, and virtually have denied His incarnation. If He is to save others, Himself He cannot save (Mt 27 42). In passing, it is well to notice that "the temptations all turn on the conflict which arises, when one, who is conscious of supernatural power, feels that there are occasions, when it would not be right to exercise it." So the miraculous is here most deeply imbedded in the first principles of Messianic action.

(3) *The second temptation.*—The pinnacle of the temple was probably the southeast corner of the roof of the Royal Cloister, 326 ft. above the bottom of the Kidron valley. The proposition was not to

leap from this height into the crowd below in the temple courts, as is usually said, for (a) there is no hint of the people in the narrative; (b) Jesus' reply does not fit such an idea; it meets another temptation entirely; (c) this explanation confuses the narrative, making the second temptation a short road to glory like the third; (d) it seems a fantastic temptation, when it is seriously visualized. Rather Satan bids Jesus leap into the abyss *outside* the temple. Why then the temple at all, and not some mountain precipice? asks Meyer. Because it was the sheerest depth well known to the Jews, who had all shuddered as they had looked down into it (Mt 4 5-7 || Lk 4 5-8).

The first temptation proved Jesus a man of faith, and the second is addressed to Him as such, asking Him to prove His faith by putting God's promise to the test. It is the temptation to fanaticism, which has been the destruction of many a useful servant of God. Jesus refuses to yield, for yielding would have been sin. It would have been (a) wicked presumption, as though God must yield to every unreasonable whim of the man of faith, and so would have been a real "tempting" of God; (b) it would have denied His incarnation in principle, like the first temptation; (c) such fanaticism would have destroyed His ministry. So the principle was evolved: Jesus will not, of self-will, run into dangers, but will avoid them except in the clear path of duty. He will be no fanatic, running before the Spirit, but will be led by Him in paths of holy sanity and heavenly wisdom. Jesus waited on God.

(4) *The third temptation.*—The former tests have proved Jesus a man of faith and of common sense. Surely such a man will take the short and easy road to that universal dominion which rightfully belongs to the Messiah. Satan offers it, as the prince of this world. The lure here is the desire for power, in itself a right instinct, and the natural and proper wish to avoid difficulty and pain. That the final object is to set up a universal kingdom of God in righteousness adds to the subtlety of the temptation. But as a condition Satan demands that Jesus shall worship him. This must be symbolically interpreted. Such worship as is offered God cannot be meant, for every pious soul would shrink from that in horror, and for Jesus it could constitute no temptation at all. Rather a compromise with Satan must be meant—such a compromise as would essentially be a submission to him. Recalling the views of the times and the course of Jesus' ministry, we can think this compromise nothing else than the adoption by Jesus of the program of political Messiahship, with its worldly means of war, intrigue, etc. Jesus repudiates the offer. He sees in it only evil, for (a) war, esp. aggressive war, is to His mind a vast crime against love, (b) it changes the basis of His kingdom from the spiritual to the external, (c) the means would defeat the end, and involve Him in disaster. He will serve God only, and God is served in righteousness. Only means which God approves can be used (Mt 4 8-11 || Lk 4 9-13). Here then is the third great principle of the kingdom: Only moral and spiritual means to moral and spiritual ends. He turns away from worldly methods to the slow and difficult way of truth-preaching, which can end only with the cross. Jesus must have come from His temptation with the conviction that His ministry meant a life-and-death struggle with all the forces of darkness.

As we should expect of Jesus, He throws the story of the inner conflict of His soul into story form.

So only could it be understood by all classes of men in all ages. It was a real struggle, but pictorially, symbolically described. This seems to be proved by various elements in the story, viz. the devil can hardly be conceived as literally taking Jesus from place to place. There is no mountain from which all the

kingdoms of the world can be seen. This view of the matter relieves all the difficulties.

The difficulty is that there can be no drawing toward an object unless the object seems desirable.

But the very fact that a sinful object seems desirable is itself sin. How then can a sinless person really be tempted at all? Possibly an analysis of each temptation will furnish the answer. In each case the appeal was a real appeal to a perfectly innocent natural instinct or appetite. In the first temptation, it was to hunger; in the second, to faith; in the third, to power as a means of establishing righteousness. In each case, Jesus felt the tug and pull of the natural instinct; how insistent is the demand of hunger, for instance! Yet, when He perceived that the satisfaction of these desires was sinful under the conditions, He immediately refused their clamorous appeal. It was a glorious moral victory. It was not that He was metaphysically not able to sin, but that He was so pure that He was able not to sin. He did not prove in the wilderness that He could not be tempted, but that He could overcome the tempter. If it is then said that Jesus, never having sinned, can have no real sympathy with sinners, the answer is twofold: (1) Not he who falls at the first assault feels the full force of temptation, but he who, like Jesus, resists it through long years to the end. (2) Only the victor can help the vanquished; only he, who has felt the most dreadful assaults and yet has stood firm, can give the help needed by the fallen.

LITERATURE.—Broadus on Mt, in loc.; Rhees, *Life of Jesus of Nazareth*, secs. 91-96; Sanday, *Outlines of the Life of Christ*, sec. 13; Holtzmann, *Hand-Commentar*, I, 67 f; J. Weiss, *Die Schriften des NT*, I, 227 f; Weiss, *Life of Christ*, I, 337-54; Dods, art. "Temptation," in *DCCG*; Garvie, *Expos T*, X (1898-99).

F. L. ANDERSON

TEN (עָשָׂר, 'eser; δέκα, déka). See NUMBER.

### TEN COMMANDMENTS, THE:

- I. THE TEN COMMANDMENTS AN ISRAELITISH CODE
- II. THE PROMULGATION OF THE DECALOGUE
- III. ANALYSIS OF THE DECALOGUE WITH BRIEF EXEGETICAL NOTES
  1. How Numbered
  2. How Grouped
  3. Original Form
  4. Brief Exegetical Notes
- IV. JESUS AND THE TEN COMMANDMENTS

#### LITERATURE

In the OT the Decalogue is uniformly referred to as "the ten words" (Ex 34 28m; Dt 4 13m; 10 4m), or simply as "the words" spoken by Jeh (Ex 20 1; 34 27; Dt 5 22; 10 2), or as "the words of the covenant" (Ex 34 28). In the NT they are called "commandments" (Mt 19 17; Eph 6 2), as with us in most Christian lands.

*I. The Ten Commandments an Israelitish Code.*—The "ten words" were spoken by Jeh to the people whom He had but recently delivered from Egypt bondage, and then led out into the wilderness, that He might teach them His laws. It was to Israel that the Decalogue was primarily addressed, and not to all mankind. Thus the reason assigned for keeping the 5th commandment applies to the people who were on their way to the land which had been given to Abraham and his descendants (Ex 20 12); and the 4th commandment is enforced by reference to the servitude in Egypt (Dt 5 15). It is possible, then, that even in the Ten Commandments there are elements peculiar to the Mosaic system and which Our Lord and His apostles may not make a part of faith and duty for Christians. See **SABBATH**.

Of the "ten words," seven were perhaps binding on the consciences of enlightened men prior to the days of Moses: murder, adultery, theft and false

witness were already treated as crimes among the Babylonians and the Egyptians; and intelligent men knew that it was wrong to dishonor God by improper use of His name, or to show lack of respect to parents, or to covet the property of another. No doubt the sharp, ringing words in which these evils are forbidden in the Ten Commandments gave to Israel a clearer apprehension of the sins referred to than they had ever had before; and the manner in which they were grouped by the Divine speaker brought into bold relief the chief elements of the moral law. But the first two prohibitions were novelties in the religious life of the world; for men worshipped many gods, and bowed down to images of every conceivable kind. The 2d commandment was too high even for Israel to grasp at that early day; a few weeks later the people were dancing about the golden calf at the foot of Sinai. The observance of the Sabbath was probably unknown to other nations, though it may have been already known in the family of Abraham.

**II. The Promulgation of the Decalogue.**—The "ten words" were spoken by Jeh Himself from the top of the mount under circumstances the most awe-inspiring. In the early morning there were thunders and lightnings and a thick cloud upon the mount, and the voice of a trumpet exceeding loud. It is no wonder that the people trembled as they faced the smoking and quaking mount, and listened to the high demands of a holy God. Their request that all future revelations should be made through Moses as the prophet mediator was quite natural. The promulgation of the Ten Commandments stands out as the most notable event in all the wilderness sojourn of Israel. There was no greater day in history before the coming of the Son of God into the world.

After a sojourn of 40 days in the mount, Moses came down with "the two tables of the testimony, tables of stone, written with the finger of God." At the foot of the mount, when Moses saw the golden calf and the dancing throng about it, he cast the tables out of his hands and broke them in pieces (Ex 31 18; 32 15-20). Through the intercession of Moses, the wrath of Jeh was averted from Israel; and Jeh invited Moses to ascend the mount with two new tablets, on which He would write the words that were on the first tables, which were broken. Moses was commanded to write the special precepts given by God during this interview; but the Ten Commandments were written on the stone tablets by Jeh Himself (Ex 34 1-4.27-29; Dt 10 1-5). These precious tablets were later deposited in the ark of the covenant (Ex 40 20). Thus in every way possible the Ten Commandments are exalted as the most precious and directly Divine of all the precepts of the Mosaic revelation.

**III. Analysis of the Decalogue with Brief Exegetical Notes.**—That there were "ten words" is expressly stated (Ex 34 28; Dt 4 13; 10 4); but just

**1. How Numbered** For a full discussion of the various theories, see Dillmann, *Exodus*, 201-5, to whom we are indebted for much that is here set forth.

(1) Jos is the first witness for the division now common among Protestants (except Lutherans), viz. (a) foreign gods, (b) images, (c) name of God, (d) Sabbath, (e) parents, (f) murder, (g) adultery, (h) theft, (i) false witness, (j) coveting. Before him, Philo made the same arrangement, except that he followed the LXX in putting adultery before murder. This mode of counting was current with many of the church Fathers, and is now in use in the Greek Catholic church and with most Protestants.

(2) Augustine combined foreign gods and images (Ex 20 2-6) into one commandment, and following the order of Dt 5 21 (Heb 18) made the 9th commandment a prohibition of the coveting of a neighbor's wife, while the 10th prohibits the coveting of his house and other property. Roman Catholics and Lutherans accept Augustine's mode of reckoning, except that they follow the order in Ex 20 17, so that the 9th command-

ment forbids the coveting of a neighbor's house, while the 10th includes his wife and all other property.

(3) A third mode of counting is that adopted by the Jews in the early Christian centuries, which became universal among them in the Middle Ages and so down to the present time. According to this scheme, the opening statement in Ex 20 2 is the "first word," Ex 20 3-6 the second (combining foreign gods with images), while the following eight commandments are as in the common Protestant arrangement.

The division of the prohibition of coveting into two commandments is fatal to the Augustinian scheme; and the reckoning of the initial statement in Ex 20 2 as one of the "ten words" seems equally fatal to the modern Jewish method of counting. The prohibition of images, which is introduced by the solemn formula, "Thou shalt not," is surely a different "word" from the command to worship no god other than Jeh. Moreover, if nine of the "ten words" are *commandments*, it would seem reasonable to make the remaining "word" a *commandment*, if this can be done without violence to the subject-matter. See Erdmans, *Expos*, July, 1909, 21 ff.

(1) The Jews, from Philo to the present, divide the "ten words" into two groups of five each. As there were two tables, it would be natural to suppose that five commandments were recorded on each tablet, though the fact that the tablets had writing on both their sides (Ex 32 15) would seem to weaken the force of the argument for an equal division. Moreover, the first pentad, in the present text of Ex and Dt, is more than four times as long as the second.

(2) Augustine supposed that there were three commandments on the first table and seven on the second. According to his method of numbering the commandments, this would put the command to honor parents at the head of the second table, as in the third method of grouping the ten words.

(3) Calvin and many moderns assign four commandments to the first table and six to the second. This has the advantage of assigning all duties to God to the first table and all duties to men to the second. It also accords with Our Lord's reduction of the commandments to two (Mt 22 34-40).

A comparison of the text of the Decalogue in Dt 5 with that in Ex 20 reveals a goodly number of differences, esp. in the reasons assigned

**3. Original Form** for the observance of the 4th and 5th commandments, and in the text of the 10th commandment. A natural explanation of these differences is the fact that Dt employs the free-and-easy style of public discourse. The Ten Commandments are substantially the same in the two passages.

From the days of Ewald to the present, some of the leading OT scholars have held that originally all the commandments were brief and without the addition of any special reasons for their observance. According to this hypothesis, the 2d, 3d, 4th, 5th, and the 10th commandments were probably as follows: "Thou shalt not make unto thee any graven image"; "Thou shalt not take the name of Jeh thy God in vain"; "Remember the Sabbath day to keep it holy"; "Honor thy father and thy mother"; "Thou shalt not covet thy neighbor's house." This early critical theory would account for the differences in the two recensions by supposing that the motives for keeping the 2d, 3d, 4th, and 5th commandments, as well as the expansion of the 10th, were additions made through the influence of the prophetic teaching. If accompanied by a full recognition of the Divine origin of the ten words in the Mosaic era, this hypothesis might be acceptable to a thorough believer in revelation. Before acquiescing in the more radical theories of some recent scholars, such a believer will demand more cogent arguments than the critics have been able to bring forward. Thus when we are told that the Decalogue contains prohibitions that could not have been incorporated into a code before the days of Manasseh, we demand better proofs than the failure of Israel to live up to the high demands of the 2d and the 10th commandments, or a certain theory of the evolution of the history that may commend itself to the mind of naturalistic critics. Jeh was at work in the early history of Israel; and the great prophets of the 8th cent., far from creating

ethical monotheism, were reformers sent to demand that Israel should embody in daily life the teachings of the Torah.

Goethe advanced the view that Ex 34 10-28 originally contained a second decalogue.

Wellhausen (*CH*, 331 f) reconstructs this so-called decalogue as follows:

- (1) Thou shalt worship no other god (ver 14).
- (2) Thou shalt make thee no molten gods (ver 17).
- (3) The feast of unleavened bread shalt thou keep (ver 18a).
- (4) Every firstling is mine (ver 19a).
- (5) Thou shalt observe the feast of weeks (ver 22a).
- (6) And the feast of ingathering at the year's end (ver 22c).
- (7) Thou shalt not offer the blood of my sacrifice with leavened bread (ver 25a).
- (8) The fat of my feast shall not remain all night until the morning (23 15b; cf 34 25b).
- (9) The best of the first-fruits of thy ground shalt thou bring to the house of Jeh thy God (ver 26a).
- (10) Thou shalt not see the a kid in its mother's milk (ver 26b).

Addis agrees with Wellhausen that even this simpler decalogue must be put long after the time of Moses (*EB*, 1051).

Now, it is evident that the narrative in Ex 34 27 f, in its present form, means to affirm that Moses was commanded to write the precepts contained in the section immediately preceding. The Ten Commandments, as the foundation of the covenant, were written by Jeh Himself on the two tablets of stone (31 18; 32 15 f; 34 28). It is only by free critical handling of the narrative that it can be made to appear that Moses wrote on the two tables the supposed decalogue of 34 14-26. Moreover, the law of the Sabbath (34 21), which is certainly appropriate amid the ritual ordinances of Ex 34, must be omitted altogether, in order to reduce the precepts to ten; also the command in ver 23 has to be deleted. It is interesting to observe that the prohibition of molten gods (34 17), even according to radical critics, is found in the earliest body of Israelitish laws. There is no sufficient reason for denying that the 2d commandment was promulgated in the days of Moses. Jeh's requirements have always been in advance of the practice of His people.

(1) The 1st commandment prohibits the worship of any god other than Jeh. If it be said that this precept inculcates monolatry and not monotheism, the reply is ready to

**4. Brief Exegetical Notes** hand that a consistent worship of only one God is, for a people surrounded by idolaters, the best possible approach to the conclusion that there is only one true God. The organs of revelation, whatever may have been the notions and practices of the mass of the Israelitish people, always speak in words that harmonize with a strict monotheism.

(2) The 2d commandment forbids the use of images in worship; even an image of Jeh is not to be tolerated (cf Ex 32 5). Jeh's mercy is greater than His wrath; while the iniquity of the fathers descends to the third and the fourth generation for those who hate Jeh, His mercy overflows to thousands who love Him. It is doubtful whether the rendering 'showing mercy to the thousandth generation' (Ex 20 6) can be successfully defended.

(3) Jeh's name is sacred, as standing for His person; therefore it must be employed in no vain or false way. The commandment, no doubt, includes more than false swearing. Cursing, blasphemy and every profane use of Jeh's name are forbidden.

(4) As the 1st commandment inculcates the unity of God and the 2d His spirituality, so also the 3d commandment guards His name against irreverent use and the 4th sets apart the seventh day as peculiarly His day, reserved for a Sabbath. Ex 20 11 emphasizes the religious aspect of the Sabbath, while Dt 5 14 lays stress on its humane aspect, and

Dt 5 15 links it with the deliverance from bondage in Egypt.

(5) The transition from duties to God to duties to men is made naturally in the 5th commandment, which inculcates reverence for parents, to whom their children should look up with gratitude, as all men should toward the Divine Father.

(6) Human life is so precious and sacred that no man should dare to take it away by violence.

(7) The family life is safeguarded by the 7th commandment.

(8) The 8th commandment forbids theft in all its forms. It recognizes the right of personal ownership of property.

(9) The 9th commandment safeguards honor and good name among men. Slander, defamation, false testimony in court and kindred sins are included.

(10) The 10th commandment is the most searching of them all, for it forbids the inward longing, the covetous desire for what belongs to another. The presence of such a deeply spiritual command among the "ten words" shows that we have before us no mere code of laws defining crimes, but a body of ethical and spiritual precepts for the moral education of the people of Jeh.

**IV. Jesus and the Ten Commandments.**—Our Lord, in the interview with the rich young ruler, gave a recapitulation of the commandments treating of duties to men (Mk 10 19; Mt 19 18 f; Lk 18 20). He quotes the 5th, 6th, 7th, 8th and 9th commandments. The minor variations in the reports in the three Synoptic Gospels remind the student of the similar variations in Ex 20 and Dt 5. Already in the Sermon on the Mount Jesus had quoted the 6th and 7th commandments, and then had gone on to show that anger is incipient murder, and that lust is adultery in the heart (Mt 5 27-32). He takes the words of the Decalogue and extends them into the realm of thought and feeling. He may have had in mind the 3d commandment in His sharp prohibition of the Jewish habit of swearing by various things (Mt 5 33-37). As to the Sabbath, His teaching and example tended to lighten the onerous restrictions of the rabbis (Mk 2 23-28). Duty to parents He elevated above all supposed claims of vows and offerings (Mt 15 4-6). In further extension of the 8th commandment, Jesus said, "Do not defraud" (Mk 10 19); and in treating of the ethics of speech, Jesus not only condemns false witness, but also includes railing, blasphemy, and even an idle word (Mt 15 19; 12 31.36 f). In His affirmation that God is spirit (Jn 4 24), Jesus made the manufacture of images nothing but folly. All his ethical teaching might be said to be founded on the 10th commandment, which tracks sin to its lair in the mind and soul of man.

Our Lord embraced the whole range of human obligation in two, or at most three, commands: (1) "Thou shalt love the Lord thy God with all thy heart, and with all thy soul, and with all thy mind"; (2) "Thou shalt love thy neighbor as thyself" (Mt 22 37-40; cf Dt 6 5; Lev 19 18). With love such as is here described in the heart, man cannot trespass against God or his fellow-men. At the close of His ministry, on the night of the betrayal, Jesus gave to His followers a *third* commandment, not different from the two on which the whole Law hangs, but an extension of the second great commandment upward into a higher realm of self-sacrifice (Jn 13 34 f; 15 12 f.17; cf Eph 5 2; Gal 6 10; 1 Jn 3 14-18). "Thou shalt love" is the first word and the last in the teaching of Our Lord. His teaching is positive rather than negative, and so simple that a child can understand it. For the Christian, the Decalogue is no longer the highest summary of human duty. He must ever read it with sincere respect as one of the great monuments

of the love of God in the moral and religious education of mankind; but it has given place to the higher teaching of the Son of God, all that was permanently valuable in the Ten Commandments having been taken up into the teaching of Our Lord and His apostles.

LITERATURE.—Oehler, *OT Theology*, I, 267 ff; Dillmann, *Ex-Lev*, 200-219; Kuenen, *Origin and Composition of the Hexateuch*, 244; Wellhausen, *CH*, 331 f; Rothstein, *Das Bundesbuch*; Baenstch, *Das Bundesbuch*; Meissner, *Der Dekalog*; Driver, "Dt." ICC; Addis, *Documents of the Hexateuch*, I, 136 ff; R. W. Dale, *The Ten Commandments*; G. D. Boardman, *University Lectures on the Ten Commandments* (Philadelphia, 1889).

JOHN RICHARD SAMPEY

**TEN STRINGS** (שָׁרָרִים, 'āsōr). See MUSIC, I, 1, (2), (c).

**TENDER**, ten'dēr: The usual (11 out of 16 t) tr of רַחַם, *rakh*, "soft," "delicate," with the noun רַחֵם, *rōkh*, in Dt 28 56 and the vb. רָחַק, *rākhakh*, in 2 K 22 19 || 2 Ch 34 27. Attention need be called only to the following cases: In Gen 29 17, "Leah's eyes were tender," a physical defect is described ("weak-eyed"; see BLINDNESS). "Tender-hearted" in 2 Ch 13 7 means "faint-hearted," while in 2 K 22 19 || 2 Ch 34 27 ("because thy heart was tender"), it means "penitent." Contrast the modern use in Eph 4 32.

Throughout Pss (10 t) and Prov (12 10), but not elsewhere (AV has "tender love" in Dnl 1 9, RV "compassion"), EV translates רַחֲמֵי, *rahāmīm*, "bowels," by "tender mercies," and this tr has been carried into the NT as "tender mercy" (RVm "heart of mercy") for the corresponding Gr phrase *splāgchna elēous* ("bowels of mercy") in Lk 1 78; cf "tenderhearted" for *eúsplagchnos* ("right boweled") in Eph 4 32, based upon the idea of psychology widely spread among Sem people, which considers the "bowels" (*kerebh*) as the seat of all tender emotions of kindness and mercy. See BOWELS. AV also has "of tender mercy" in Jas 5 11 without justification in the Gr (*oiktīrmōn*, RV "merciful").

Other special phrases: "tender grape" in AV, Cant 2 13.15; 7 12, for רַחֲמֵי, *rahāmīm*. The meaning of the word is not quite certain, but RV's "blossom" (except 7 12 m) is probably right. "Tender grass" in 2 S 23 4; Prov 27 25; RV Dt 32 2 (AV "tender herb"); Job 38 27 (AV "tender herb"); Isa 15 6; 66 14 for שֶׁשֶׁת, *deshe*, "grass" (Aram. שֶׁשֶׁת, *dethe*, Dnl 4 15.23). The context in these passages and the meaning of the cognates of *deshe* in other Sem languages make this tr probable, but RV's usage is not consistent (cf Gen 1 11.12; Job 6 5; Ps 23 2, etc.). Isa 53 2 has "tender plant" for קַצֵּיץ, *yōnēk*, "a sapling," while Job 14 7 has "tender branch" for the allied word יֹנֵקֶת, *yōnēket*, usually rendered "shoot" (Job 8 16, etc.). Finally, "tender" in Mk 13 28; Mt 24 32 is for ἀπαλός, *hapalós*, "soft." The running sap of springtime softens the branches that were stiff during the winter.

The vb. "tender" occurs in 2 Macc 4 2, AV "[he had] tendered his own nation," in the modern sense of "tend." The tr is a paraphrase of the noun κηδεμών, *kēdemōn*, "a protector," RV "the guardian of his fellow-countrymen."

BURTON SCOTT EASTON

**TENON**, ten'un (טֵן, *yādth*): This word, occurring in Ex 26 and 36, is used in the account of the tabernacle to describe the "hand" or *yādth* by which its 48 boards were kept in place. Each board had two tenons which were mortised into it (Ex 36 22m). These tenons would be made of harder wood than the acacia, so as better to stand the strain of wind and weather. When in use the tenons were sunk into the "sockets" (q.v.), and allowed of a speedy reërection of the tabernacle at its every remove.

Sockets are also mentioned as in use for the stand-

ards of the tabernacle court (Ex 27 10 ff), but there is no mention of tenons. It may be that the base of each standard was let into its socket, without the use of any tenon. This would give it sufficient stability, as the height of each standard was but 5 cubits (7½ ft.) (Ex 27 18).

For Professor A. R. S. Kennedy's different theory of "tenons," see TABERNACLE, and his own art. on the "Tabernacle" in HDB, IV.

W. SHAW CALDECOTT

**TENT**, tent (אֹהֶל, 'ōhel; σκηνή, *skēnē*; 'ōhel is a derivative of אָהַל, 'ahal, "to be clear," "to shine"; hence 'ōhel, "to be conspicuous from a distance"): In the great stretches of uncultivated lands in the interior of Syria or Arabia, which probably have much the same aspect today as in Abraham's time, it is an easy matter to espy an encampment of roving Bedouin, "a nation . . . that dwelleth without care . . . that have neither gates nor bars" (Jer 49 31). The peaks of their black (cf Cant 1 5) goats' hair tents stand out in contrast against the lighter colors of the soil.

There seems to be little doubt about the antiquity of the Arab tent, and one can rightly believe that the dwelling-places of Abraham, Sarah, Jacob, and their descendants were made on the same pattern and of the same materials (Gen 4 20; 9 27; 12 8; 13 3; 18 6; 31 25.33; Ps 78 55; He 11 9, etc.). Long after the children of Israel had given up their tents for houses they continued to worship in tents (2 S 7 1-6; 2 Ch 1 3.4) (for the use of tents in connection with religious observances see TABERNACLE).

The Arab tents (called *baït sha'r*, "house of hair") are made of strips of black goats' hair cloth, sewed together into one large piece (see GOATS' HAIR; WEAVING). Poles are placed under this covering at intervals to hold it from the ground, and it is stretched over these poles by ropes of goats' hair or hemp (cf Job 4 21; Isa 54 2; Jer 10 20), fastened to hard-wood pins driven into the ground (Isa 54 2; Jgs 4 21; 5 26). A large wooden mallet for driving the pegs is part of the regular camp equipment (Jgs 4 21; 5 26). The sides (curtains) of the tent (Isa 54 2) are made of strips of goats' hair cloth, or from mats woven from split cane or rushes (see illustration, p. 2948). Where more than one family occupies the same tent or the animals are provided with shelter under the same roof (cf 2 Ch 14 15), curtains of the same materials mentioned above form the dividing walls. A corner of the matting where two ends meet is turned back to form the door of the tent (Gen 18 1). In the summer time the walls are mostly removed. New tents are not water-proof, and the condition of the interior after a heavy rain is not far from squalid. The tent material becomes matted by use, esp. if wool has been woven into the fabric, and is then a better protection against the rain. It is the women's duty to pitch the tents.

The poorer Arabs have no mats to cover the ground under their tents. Straw mats, goats' hair or woolen rugs (cf Jgs 4 18), more or less elaborate as the taste and means of the family allow, are the usual coverings for the tent floor. The food supplies are usually kept in goats' hair bags, the liquids, as oil or milk products, in skins. One or two tinned copper cooking-vessels, a shallow tray of the same material, a coffee set consisting of roasting pan, mortar and pestle, boiling-pot and cups, make up the usual camp furniture. The more thrifty include bedding in their equipment, but this increases the difficulties of moving, since it might require more than the one animal, sometimes only a donkey, which carries all the earthly belongings of the family. A *sheikh* or chief has several tents, one for himself and

guests, separate ones for his wives and female servants, and still others for his animals (cf Gen 31 33).

Other Heb words trad "tent" are forms of תֵּן, *hānāh* (Nu 13 19; 1 S 17 53; 2 K 7 16; 2 Ch 31 2; Zec 14 15); שִׁכָּה, *shukkah* (2 S 11 11; 22 12); מִשְׁכַּנֹּת, *mishkanoth* (Cant 1 8).

Figurative: "Neither shall the Arabian pitch tent there" typified utter desolation (Isa 13 20). "Enlarge the place of thy tent . . . stretch forth the curtains . . . lengthen thy cords . . . strengthen thy stakes" prophesied an increase in numbers and prosperity of God's people (Isa 54 2; cf 33 20; Lk 16 9; 2 Cor 5 4). Tent cords plucked up denoted death (Job 4 21). Jer 10 20

Paul dwelt with Aquila and Priscilla, and worked with them at tent-making (cf Acts 20 34). See also CRAFTS, II, 18.

**TEPHON**, *tē'fon* (ἡ Τεφώ, *hē Tephō*): In 1 Macc 9 50, a city of Judaea fortified by Bacchides, probably the "Beth-tappuah" of Josh 15 53, near Hebron. Jos (*Ant*, XII, i, 3) calls it "Tochoa."

**TERAH**, *tē'ra* (תְּרָח, *terah*; LXX Θάρρα, *Thárra*, or [with NT] Θάρα, *Thára*; on the name see esp. *HDB*, s.v.): The son of Nahor and father of Abraham, Nahor and Haran (Gen 11 24 f). At Abraham's birth Terah was 70 years old (11 26), and after Abraham's marriage, Terah, Abraham, Sarah



ARAB TENT.

1. Tent. 2. Curtain of goats' hair. 2a. Curtain of split reed. 2b. Curtain of rushes. 3. Tent rug. 4. Warp of loom (see WRAYING). 5. Reinforcing of narrow goats' hair strip to hold rope, similar reinforcing under pole. 6. Tent rope. 7. One of the seams showing manner of sewing. (Behind 2a are bags of flour, etc.)

is a picture of a destroyed household as applied to Judah. Hezekiah in his sickness bewails that his dwelling (life) had been carried away as easily as a shepherd's tent is plucked up (Isa 38 12). Isaiah compared the heavens to a tent spread out (Isa 40 22). "They shall pitch their tents against her" i.e. they shall make war (Jer 6 3).

JAMES A. PATCH

**TENTH.** See TITHES.

**TENTH DEAL**, *dāl* (עֲשָׂרֹן, *'issārōn*): The tenth part of an ephah, and so rendered in RV (Nu 28, 29). It was used in connection with the sacrifices for measuring flour.

**TENT-MAKER**, *tent'māk-ēr* (σκηνοποιός, *skēnopoios*): Mentioned only once (Acts 18 3). Paul's native province of Cilicia was noted for its goats' hair cloth which was exported under the name of *cilicium* and was used largely for tent-making. We are told in the passage mentioned that

and Lot emigrated from Ur of the Chaldees on the road into the land of Canaan, but stopped in Haran (11 31). When Abraham was 75 years old he and his nephew resumed their journey, leaving Terah in Haran, where 60 years later he died (11 32). St. Stephen, however, states (Acts 7 4) that Terah was dead when Abraham left Haran, an impression that is easily gained from Gen 11-12 if the dates are not computed. As there is no reason to suppose that St. Stephen was granted inspiration that would preserve him from such a purely formal error, the contradiction is of no significance and attempts at "reconciliation" are needless. In particular, the attempt of Blass (*Stud. u. Krit.*, 1896, 460 ff) to alter the text of Acts is quite without foundation. For further discussion see esp. Knowling, *Expos Gr Test.*, ad loc. It is worth noting that Philo makes the same error (*Migr. Abr.* 177 [§32]), perhaps indicating some special Jewish tradition of NT times. In Josh 24 2 Terah is said to have been an idolater. In Jub 12 this is softened into explaining that

through fear of his life Terah was forced to yield outward conformity to the idolatrous worship of his neighbors. On the other hand certain Jewish legends (e.g. *B'r. Rab.* 17) represent Terah as actually a maker of idols. Otherwise in the Bible Terah is mentioned only by name in 1 Ch 1 26; Lk 3 34. BURTON SCOTT EASTON

**TERAH** (B, *Tápaθ, Tárath, A, Θάραθ, Tháraith*): A wilderness camp of the Israelites between Tahath and Mithkah (Nu 33 27.28). See WANDERINGS OF ISRAEL.

**TERAPHIM**, ter'a-fim. See ASTROLOGY; DIVINATION; IMAGES.

**TEREBINTH**, ter'é-binth: (1) *אֵלֶּה*, 'eláh (Isa 6 13, AV "teal tree"; Hos 4 13, AV "elms"); in Gen 35 4 (AV "oak"); Jgs 6 11.19; 9 6 (AV "plain"); 2 S 18 9.10.14; 1 K 13 14; 1 Ch 10 12; Isa 1 30; Ezk 6 13, tr<sup>d</sup> "oak," and in m "terebinth"; "vale of Elah," m "the terebinth" in 1 S 17 2.19; 21 9. (2) *אֵילִים*, 'elím (Isa 1 29, "oaks," m "terebinths"). (3) *אֵלֶּה*, 'alláh (Josh 24 26, EV "oak," but LXX *τερέβινθος, terébinthos*). (4) *אֵילֶּן*, 'elón, "oak [m "terebinth"] of Zaannaim" (Josh 19 33; Jgs 4 11); "oak [RVm "terebinth," AV "plain"] of Tabor" (1 S 10 3); also Gen 12 6; 13 18; 14 13; 1 S 10 3; Dt 11 30; Jgs 6 19 all tr<sup>d</sup> "oak" or "oaks," with m "terebinth" or "terebinths." (5) In Gen 14 6 LXX has *τερέβινθος, terébinthos*, as the tr of the *el* of El-paran. (6) In Ecclus 24 16 *τερέβινθος, terém(b)inthus*, AV "turpentine tree," RV "terebinth."

It is clear that the translators are uncertain which tr is correct, and it would seem not improbable that then there was no clear distinction between oak and terebinth in the minds of the OT writers; yet the two are very different trees to any but the most superficial observation.

The terebinth—*Pistacia terebinthus* (N.O. *Anacardiaceae*), Arab. *Butm*—is a tree allied to the *P. vera*, which produces the pistachio nut, and to the familiar "pepper tree" (*Schinus molle*) so extensively cultivated in modern Pal. Like the latter the terebinth has red berries, like small immature grapes. The leaves are pinnate, four to six pairs, and they change color and fall in autumn, leaving the trunk bare (cf Isa 1 30). The terebinth is liable to be infected by many showy galls, some varieties looking like pieces of red coral. In Pal, this tree assumes noble proportions, esp. in situations when, from its association with some sacred tomb, it is allowed to flourish undisturbed. It is in such situations not infrequently as much as 40 ft. high and spreads its branches, with their thick, dark-green foliage, over a wide area (cf 2 S 18 9 f.14; Ecclus 24 16). Dwarfed trees occur among the brushwood all over the land.

From this tree a kind of turpentine is obtained, hence the alternative name "turpentine tree" (Ecclus 24 16 AV, RV "terebinth").

E. W. G. MASTERMAN

**TERESH**, té'resh (תֵּרֶשׁ), *teresh* [Est 2 21; 6 2]; B A N omit, N m, *Θάρας, Tháras, and Θάρπας, Tháras*): A chamberlain of King Ahasuerus. Oppert compares the name with Tiri-dates, the name of the governor of Persepolis in the time of Alexander. Another explanation identifies it with the Pers word *turš*, "firm"; Scheft links it with the Pers *tarsha*, "desire."

**TERRACE**, ter'ás (מִסְלָלָה, *m'silláh*): Solomon is said, in 2 Ch 9 11, to have made of the algum trees brought him from Ophir "terraces," or raised

walks, for the house of Jeh. In the || 1 K 10 12, the word used is rendered "pillars," m "'a railing"; Heb 'a prop.'"

**TERRIBLE**, ter'i-b'l, **TERROR**, ter'er (אָרֵר, *yārē'*, "to be feared," "reverenced," עָרַר, *'aric*, "powerful," "tyrannical," אָצִים, *'ayōm*, "awe-inspiring," "tyrannical," הַיִּלְלִיחַ, *hállith*, "terror," בַּלְלָהָה, *balláhah*, "a worn-out or wasted thing," אֲמָה, *'emáh*, "fright"; *φοβερός, phoberós*, "dreadful," *φόβος, phóbos*, "fear"): The above terms, and many others which are employed, denote whatever, by horrible aspect, or by greatness, power, or cruelty, affrights men (Dt 1 19; 26 8; Dnl 2 31). God is terrible by reason of His awful greatness, His infinite power, His inscrutable dealings, His perfect holiness, His covenant faithfulness, His strict justice and fearful judgments (Ex 34 10; Dt 7 21; Neh 9 32; Job 6 4; 37 22; Ps 65 5; 88 15 f; Joel 2 11; Zeph 2 11; He 12 21). The term is also applied to the enemies of God and of His people (Isa 13 11; 25 3 ff; 49 25; Dnl 7 7; 1 Pet 3 14). "The terror [RV "fear"] of the Lord" (2 Cor 5 11) denotes the reverence or fear inspired by the thought that Christ is judge (ver 10). M. O. EVANS

**TERTIUS**, túr'shi-us (Τέρτιος, *Tértios*): The amanuensis of Paul who wrote at his dictation the Ep. to the Rom. In the midst of Paul's greetings to the Christians in Rome he interpolated his own, "I Tertius, who write the epistle, salute you in the Lord" (Rom 16 22). "It is as a Christian, not in virtue of any other relation he has to the Romans, that Tertius salutes them" (Denney). Some identify him with Silas, owing to the fact that *shālīsh* is the Heb for "third [officer]," as *tertius* is the Lat. Others think he was a Rom Christian residing in Corinth. This is, however, merely conjecture. Paul seems to have dictated his letters to an amanuensis, adding by his own hand merely the concluding sentences as "the token in every epistle" (2 Thess 3 17; Col 4 18; 1 Cor 16 21). How far this may have influenced the style of his letters is discussed in Sanday-Headlam, *Romans*, Intro, lx.

S. F. HUNTER

**TERTULLUS**, ter-tul'us, tēr-(Τέρτυλλος, *Tértullos*, diminutive of Lat *tertius*, "third"): An orator who descended with Ananias the high priest and elders from Jerus to Caesarea to accuse Paul before Felix the Rom governor (Acts 24 1). Tertullus was a hired pleader whose services were necessary that the case for the Jews might be stated in proper form. Although he bore a Rom name, he was not necessarily a Roman; Rom names were common both among Greeks and Jews, and most orators were at this time of eastern extraction. Nor is it definitely to be concluded from the manner of his speech (Acts 24 2-8) that he was a Jew; it has always been customary for lawyers to identify themselves in their pleading with their clients. His speech before Felix is marked by considerable ingenuity. It begins with an adulation of the governorship of Felix that was little in accord with history (see FELIX); and the subsequent argument is an example of how a strong case may apparently be made out by the skilful manipulation of half-truths. Thus the riot at Jerus was ascribed to the sedition-mongering of Paul, who thereby proved himself an enemy of Rom rule and Jewish religion, both of which Felix was pledged to uphold. Again, the arrest of Paul was not an act of mob violence, but was legally carried out by the high priests and elders in the interests of peace; and but for the unwarranted interference of Lysias (see LYSIAS), they would have dealt with the prisoner in their own courts and thus have avoided tres-

passing on the time of Felix. They were, however, perfectly willing to submit the whole case to his jurisdiction. It is interesting to compare this speech of Tertullus with the true account, as given in Acts 21 27-35, and also with the letter of Lysias (Acts 23 26-30). C. M. KERR

**TESTAMENT**, tes'ta-ment: The word *διαθήκη*, *diathēkē*, almost invariably rendered "covenant," was rendered in AV "testament" in He 9 16,17, in the sense of a will to dispose of property after the maker's death. It is not easy to find justification for the retention of this tr in RV, "esp. in a book which is so impregnated with the language of the LXX as the Ep. to the He" (Hatch). See COVENANT IN THE NT.

**TESTAMENT, NEW, CANON OF THE.** See CANON OF THE NEW TESTAMENT.

**TESTAMENT, NEW, TEXT AND MANUSCRIPTS OF THE.** See TEXT AND MSS OF THE NT.

**TESTAMENT OF ISAAC.** See APOCALYPTIC LITERATURE, IV, 3.

**TESTAMENT, OLD, CANON OF THE.** See CANON OF THE OLD TESTAMENT.

**TESTAMENT, OLD, TEXT OF THE.** See TEXT OF THE OLD TESTAMENT.

**TESTAMENTS, BETWEEN THE.** See BETWEEN THE TESTAMENTS.

**TESTAMENTS OF THE TWELVE PATRIARCHS.** See APOCALYPTIC LITERATURE, IV, 1.

**TESTIMONY**, tes'ti-mō-ni, ARK OF THE (Ex 25 21 f). See ARK OF THE COVENANT.

**TETA**, tē'ta. See ATETA.

**TETH**, teth (ט): The 9th letter of the Heb alphabet; transliterated in this Encyclopaedia as *t* (intense *t*). It came also to be used for the number 9; and with *wāw* for 15, with *zāyin* for 16 (i.e. 9+6 and 9+7) to avoid forming regular series with the abbreviation for Jeh. For name, etc, see ALPHABET.

**TETRARCH**, tē'trārk, tet'rārk (τετράρχης, *tetrārchēs*): As the name indicates it signifies a prince, who governs one-fourth of a domain or kingdom. The Greeks first used the word. Thus Philip of Macedon divided Thessaly into four "tetrarchies." Later on the Romans adopted the term and applied it to any ruler of a small principality. It is not synonymous with "ethnarch," at least the Romans made a distinction between Herod "tetrarch" of Galilee, Philip "tetrarch" of Trachonitis, Lysanias "tetrarch" of Abilene, and Archelāus "ethnarch" of Judaea (BJ, II, vi, 3; Ant, XVII, xi, 4). The title was often conferred on Herodian princes by the Romans, and sometimes it was used courteously as a synonym for king (Mt 14 9; Mk 6 14). In the same way a "tetrarchy" was sometimes called a kingdom.

HENRY E. DOSKER

**TETTER**, tet'ēr (קַרְבָּב, *bōhak*; ἄλφος, *álfhos*): The term "freckled spot" in AV is thus rendered in RV. The eruption referred to in Lev 13 39 is a pale white spot on the skin. This is described by Gorraeus as an eruption arising from a diseased state of the system without roughness of skin, scales or ulceration. It did not render the sufferer unclean, although it is difficult of cure. The disease is commonly known by its Lat name *vittiligo*. Pliny rec-

ommended the use of capers and lupins to remove it. See FRECKLED SPOT; LEPROSY.

**TEXT AND MANUSCRIPTS OF THE NEW TESTAMENT:**

- I. SOURCES OF EVIDENCE FOR THE TEXT OF THE NT
  - 1. Autographs of the NT Writers
  - 2. Papyrus Fragments of the Greek NT
  - 3. Greek Copies or MSS of the NT Text
  - 4. List of MSS of the Greek NT
    - (1) Uncials
    - (2) Minuscules
  - 5. Vernacular Versions
  - 6. Patristic Quotations
  - 7. Lectionaries and Service-Books
- II. NECESSITY OF SIFTING AND CRITICIZING THE EVIDENCE
- III. METHODS OF CRITICAL PROCEDURE
- IV. HISTORY OF THE PROCESS

The literary evidence to the text of the NT is vastly more abundant than that to any other series of writings of like compass in the entire range of ancient letters. Of the sacred books of the Heb Bible there is no known copy antedating the 10th cent. AD. Of Homer there is no complete copy earlier than the 13th cent. Of Herodotus there is no MS earlier than the 10th cent. Of Vergil but one copy is earlier than the 4th cent., and but a fragment of all Cicero's writings is even as old as this. Of the NT, however, we have two splendid MSS of the 4th cent., at least ten of the 5th, twenty-five of the 6th and in all a total of more than four thousand copies in whole or in part of the Gr NT. To these copies of the text itself may be added the very important and even more ancient evidence of the VSS of the NT in the Lat, Syr, and Egyp tongues, and the quotations and clear references to the NT readings found in the works of the early Church Fathers, as well as the inscriptions and monumental data in Syria, Asia Minor, Africa, Italy, and Greece, dating from the very age of the apostles and their immediate successors. It thus appears that the documents of the Christian faith are both so many and so widely scattered that these very facts more than any others have embarrassed the final determination of the text. Now, however, the science of textual criticism has so far advanced and the textual problems of the Gr Testament have been so well traversed that one may read the Christian writings with an assurance approximating certainty.

Professor Eberhard Nestle speaks of the Gr text of the NT issued by Westcott and Hort as the "nearest in its approach to the goal." Professor Alexander Souter's student's edition of the Revisers' Gr NT, Oxford, 1910, no doubt attains even a higher watermark. It is the purpose of the present article to trace, as far as it can be done in a clear and untechnical manner, the process of connection between the original writings and this, one of the latest of the editions of the Gr NT.

**I. Sources of Evidence for the Text of the NT.**—Until very recent times it has not been customary to take up with any degree of

1. The confidence, if at all, the subject of NT Autographs autographs, but since the researches of the NT in particular of Dalman, Deissmann, Writers Moulton (W. F.) and Milligan (George), the task is not only appropriate but incumbent upon the careful student. The whole tendency of recent investigation is to give less place to the oral tradition of Christ's life and teaching and to press back the date of the writing of the Synoptic Gospels into the period falling between Pentecost and the destruction of Jerus. Sir William M. Ramsay goes so far as to claim that "antecedent probability founded on the general character of personal and contemporary Greek of Gr-Asiatic society" would indicate "that the first Christian account of the circumstances connected



with the death of Jesus must be presumed to have been written in the year when Jesus died" (*Letters to the Seven Churches*, 7). W. M. Flinders Petrie argues to the same end and says: "Some generally accepted Gospels must have been in circulation before 60 AD. The mass of briefer records and Logia which the habits and culture of that age would produce must have been welded together within 10 or 20 years by the external necessities" (*The Growth of the Gospels*, 7).

The autographs of the NT writers have long been

sometimes with a sentence or two at the end. The method of personal research was pursued, as well as compilation of diverse data including folklore and genealogies, together with the grouping of cognate matters in artistic forms and abundant quotation in writings held in high esteem by the readers, as in the First and Third Gospels and the Book of Acts. The presentation copy of one's works must have been written with unusual pains in case of their dedication to a patrician patron, as Lk to "most excellent Theophilus." For specula-

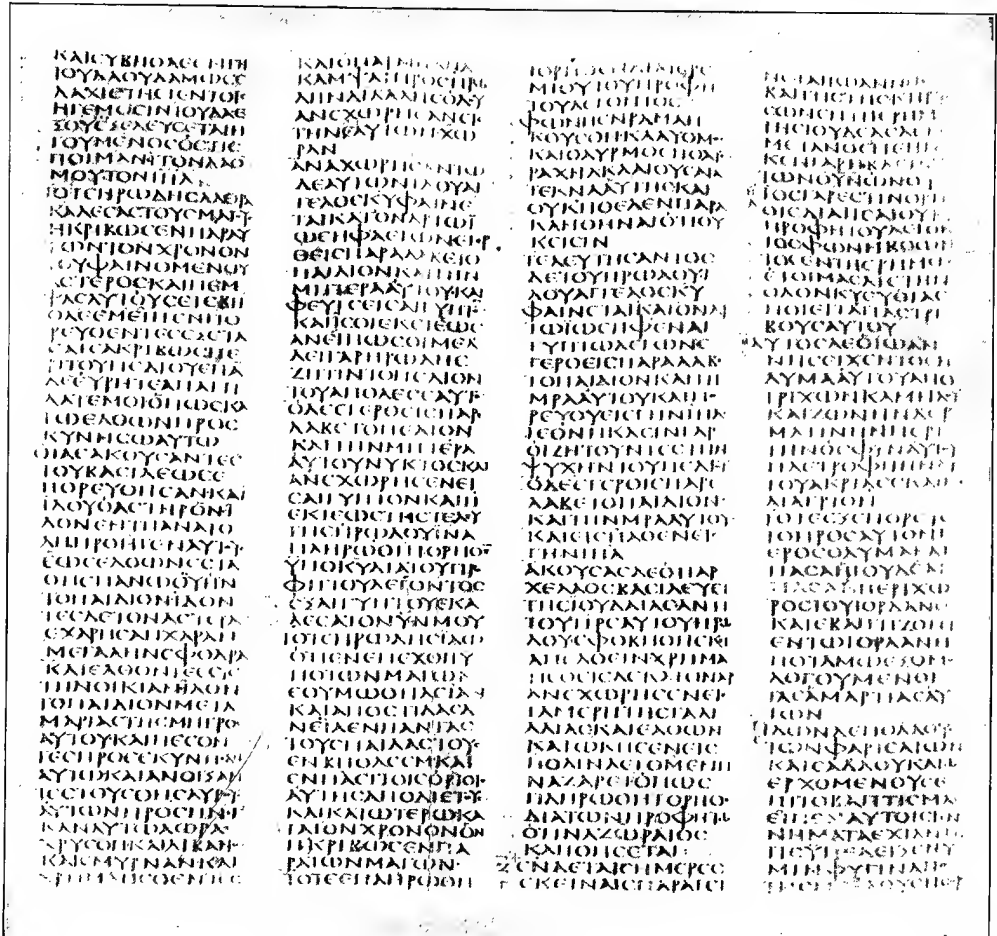

FIG. 1.—FACSIMILE OF COD. SINAITICUS.

lost, but the discovery during the last few years of contemporary documents enables us to form fairly clear notions as to their general literary character and condition. In the first place papyrus was probably the material employed by all the NT writers, even the original Gospel of Mt and the general Ep. of Jas, the only books written within Pal, not being excepted, for the reason that they were not originally written with a view to their liturgical use, in which case vellum might possibly have been employed. Again the evidence of the writings themselves witnesses to the various literary processes followed during the 1st cent. Dictation was largely followed by St. Paul, the names of at least four of his secretaries, Tertius, Sosthenes, Timothy, and Sylvanus, being given, while the master himself, as in many of the Egypt papyri, appended his own signature,

tion as to the probable dimensions of the original papyrus rolls of NT books, one will find Professor J. Rendel Harris and Sir F. G. Kenyon extremely suggestive, and from opposite viewpoints; cf Kenyon, *Handbook of the Textual Criticism of the NT*; Harris, *NT Autographs*.

Comparatively few papyrus fragments of the NT are now known to be extant, and no complete book of the NT has as yet been found, though the successes in the field of contemporary Gr writings inspire confidence that ere long the rubbish heaps of Egypt will reward the diligent explorer. Of the LXX (Gr OT) somewhat more has come to light than the NT, while the papyrus copies and fragments of Homer are almost daily increasing.

The list below is condensed from that of Sir Frederick G. Kenyon's *Handbook of the Textual Criticism of the*

NT, 2d ed, 1912, 41 ff, using Dr. Gregory's method of notation.

<sup>31</sup> Mt 1 1-9.12.14-20. 3d cent. Found at Oxyrhynchus in 1896, now in the University of Pennsylvania.

**2. Papyrus Fragments of the Greek NT** <sup>32</sup> Jn 12 12-15 in Gr on the verso, with Lk 7 18 ff in Sahidic on the recto. 5th or 6th cent. In book form, at the Museo Archeologico, Florence. <sup>33</sup> Lk 7 36-43; 10 38-42. 6th cent. In book form. In the Rainer Collection, Vienna.

<sup>34</sup> Lk 1 74-80; 5 3-8.30-6 4. 4th cent. In book form. Found in Egypt joined to a MS of Philo; now in the Bibliothèque Nationale, Paris.

<sup>35</sup> Jn 1 23-31.33-41; 20 11-17.19-25. 3d cent. An outer sheet of a single-quire book. Found at Oxyrhynchus and now in the British Museum.

<sup>36</sup> Jn 11 45. University of Strassburg.

<sup>37</sup> Lk 4 1.2. Archaeological Museum at Kieff.

<sup>38</sup> Acts 4 31-37; 5 2-9; 6 1-6.8-15. 4th cent. In the Berlin Museum.

<sup>39</sup> 1 Jn 4 11-13.15-17. 4th or 5th cent. In book form. Found at Oxyrhynchus; now in Harvard University Library.

<sup>40</sup> Rom 1 1-7. 4th cent. Found at Oxyrhynchus; now in Harvard University Library.

<sup>41</sup> 1 Cor 1 17-20; 6 13-18; 7 3.4.10-14. 5th cent. In the Imperial Library at St. Petersburg.

<sup>42</sup> He 1 1. 3d or 4th cent. In the Amherst Library.

<sup>43</sup> He 2 14-5 5; 10 8-11 13; 11 28-12 17. 3d or 4th cent. Found at Oxyrhynchus; now in the British Museum.

<sup>44</sup> 1 Cor 1 25-27; 2 3-8; 3 8-10.20. 5th cent. In book form; at St. Catherine's Monastery, Mt. Sinai.

<sup>45</sup> 1 Cor 7 18-8 4; Phil 3 9-17; 4 2-8. 4th cent. Found at Oxyrhynchus.

<sup>46</sup> Rom 12 3-8. 6th or 7th cent. Ryland's Library, Manchester.

<sup>47</sup> Tit 1 11-15; 2 3-8. 3d cent. Ryland's Library, Manchester.

<sup>48</sup> He 9 12-19. 4th cent. Found at Oxyrhynchus.

<sup>49</sup> Rev 1 4-7. 3d or 4th cent. Found at Oxyrhynchus.

Gr copies or MSS of the NT text have hitherto been and probably will continue to be the chief source of data in this great field.

**3. Greek Copies or MSS of the NT Text** For determining the existence of the text in its most ancient form the auto-MSS of the graphs are of supreme value. For determining the content or extent of the text the VSS are of highest worth.

For estimating the meaning and at the same time for gaining additional data, both as to existence and extent of usage of the NT, the quotations of its text by the Church Fathers, whether as apologists, preachers, or historians, in Assyria, Greece, Africa, Italy or Gaul, are of exceeding importance. But for determining the readings of the text itself the Gr MSS or copies of the original autographs are still the principal evidence of criticism. About 4,000 MSS, in whole or in part, of the Gr NT are now known. These MSS furnish abundant evidence for determining the reading of practically the entire NT, while for the Gospels and most important Epp. the evidence is unprecedented for quantity and for clearness. They are usually divided into two classes: Uncial, or large hand, and Minuscule, or small hand, often called Cursive. The term "cursive" is not satisfactory, since it does not coördinate with the term "uncial," nor are so-called cursive features such as ligatures and oval forms confined to minuscule MSS. The uncials comprise about 140 copies extending from the 4th to the 10th cents. The minuscules include the remaining MSS and fall between the 9th cent. and the invention of printing. Herewith is given a brief description of a few of the chief MSS, both uncial and minuscule, of the NT.

(1) *Uncials*.—**N**. Cod. Sinaiticus found by Tischendorf at St. Catherine's Monastery on Mt. Sinai and now in the Imperial Library at

**4. List of MSS of the only uncial which contains the NT Greek NT** St. Petersburg; 4th cent. This is the entire. It also has the Ep. of Barnabas and part of the Shepherd of Hermas and possibly originally the *Didache*. The marks of

many correctors are found in the text. It is written on 147½ leaves of very thin vellum in four narrow columns of 48 lines each. The pages measure 15×13½ in., and the leaves are arranged in quaternions of four sheets. The open sheet exposing eight columns resembles greatly an open papyrus roll. There is but rudimentary punctuation and no use of accent or initial letters, but the Eusebian section numbers are found on the margin of the Gospels. Fig. 1 is from the photographic facsimile of **N**, published by the Oxford University Press in 1911.

**A**. Cod. Alexandrinus, so named since it was supposed to have come from Alexandria, being the gift of Cyril Lucar, at one time Patriarch of that Province, though later of Constantinople, to Charles I, through the English ambassador at the Turkish court in 1627, and in 1757 presented to the Royal Library and now in the British Museum. It doubtless belongs to the 5th cent., and contained the entire NT, lacking now only portions of Mt, Jn, and 1 Cor, as well as the two Epp. of Clement of Rome and the Ps Sol. It is written on thin vellum in two columns of 41 lines to the page, which is 12½×10½ in.; employs frequent initial capitals, and is divided into paragraphs, but has no marginal signs except in the Gospels. Several different hands are discovered in the present state of the MS.

**B**. Cod. Vaticanus, since 1481, at least, the chief treasure of the Vatican Library, and universally esteemed to be the oldest and best MS of the Gr NT; 4th cent. Written on very fine vellum, the leaves nearly square in shape, 10×10½ in., with three narrow columns of 40-44 lines per column and five sheets making the quire. A part of the Ep. to the He and the Pastorals, Philem and Rev are lacking. It is without accents, breathings or punctuation, though corrected and retraced by later hands. In the Gospels the divisions are of an earlier date than in Cod. **N**. The theory of Tischendorf that Codd. **N** and **B** were in part prepared by the same hand and that they were both among the 50 MSS made under the direction of Eusebius at Caesarea in 331 for use in the emperor Constantine's new capital, is not now generally accepted.

**C**. Cod. Ephraemi Rescriptus. This is the great palimpsest (twice written) MS of the uncial group, and originally contained the whole NT. Now, however, a part—approximately half—of every book is lacking, and 2 Thess and 2 Jn are entirely gone. It belongs to the 5th cent., is written on good vellum 9×12½ in. to the page of 41 lines, and of one column in the original text, though the superimposed writings of St. Ephraem are in two. Enlarged initials and the Eusebian marginal sections are used and several hands have corrected the MS. See Fig. 2. Brought to Italy from the East in the 16th cent., it came to France with Catherine de' Medici and is now in the Bibliothèque Nationale, Paris.

**D**. Cod. Bezae. This is the early known MS which Theodore Beza obtained in 1562 from the monastery of St. Irenaeus at Lyons and which he gave in 1581 to the University of Cambridge, where it now is. It is a Gr-Lat text, the Gr holding the chief place on the left-hand page, measuring 8×10 in., and dates probably from the end of the 5th cent. Both Gr and Lat are written in large uncials and divided into short clauses, corresponding line for line. The hands of no less than nine correctors have been traced, and the critical questions arising from the character of the readings are among the most interesting in the whole range of Bib. criticism and are still unsettled. It contains only the Gospels and Acts with a fragment of 3 Jn.

**W**. Cod. Washingtoniensis. The United States has now in the National Library (Smithsonian) at the capital one of the foremost uncial MSS of the

ΕΥΑΓΓΕΛΙΟΝ ΚΑΤΑ ΜΑΡΚΟΝ

ΑΡΧΗ ΤΟΥ ΕΥΑΓΓΕΛΙΟΥ ΠΟΥ ΧΥΛΙΟΝ ΕΥΑΓΓΕΛΙΟΝ  
 ΕΡΧΕΤΑΙ ΕΝ ΤΟΙΣ ΕΡΧΟΜΕΝΟΙΣ ΑΝΘΡΩΠΟΙΣ  
 ΟΣΤΙΝ ΕΛΛΩΤΟΝ ΑΚΤΕΛΟΝ ΜΟΥ ΚΡΟΝΟΣΩ  
 ΠΟΥΣΟΥ ΟΣΚΑΤΑΣΚΕΥΑΒΕΤΗΝ ΚΑΙ ΔΟΚΙΣΟΥ  
 ΦΩΝΗ ΟΩΝ ΤΟ ΓΕΝΤΗΡΗΜΩ ΒΤΑΙ ΜΑΛΑ  
 ΤΕΤΗΝ ΟΛΟΚΥ ΕΥΘΕΙΑ ΕΠΟΙΕΤΑΙ ΤΑ ΕΤΙ  
 ΒΟΥΣΑΥΤΟΥ ΠΑΣΦΑΡΕΤΣ ΠΑΝΡΩΘΟΙΔΕ  
 ΤΑΙ ΚΑΙ ΠΑΝΟΡΟΣΚΑΙ ΟΥ ΜΕΣΤΑ ΠΙΛΑΤΩΝ  
 ΟΕΤΑΙ ΚΑΙ ΕΣΤΑ ΠΑΝΤΑ ΤΑ ΚΟΛΙΑ ΕΙΣΕΥ  
 ΘΕΙΑΝ ΚΑΙ ΗΤΡΑ ΧΕΙΡΕΙΣ ΠΕΔΙΟΝ ΚΑΙ ΔΟΦΟΝ  
 ΟΕΤΑΙ Η ΔΟΞΑ ΚΥ ΚΑΙ ΟΥ ΕΤΑΙ ΠΑΝΘΕ ΑΡΤΟ  
 ΕΣΤΗΡΤΟΝ ΤΟΥ ΟΥ ΟΤΙ ΚΕ ΕΛΛΗΝΕΣ ΑΦΩΝΗ  
 ΚΕ ΓΟΝΤΟΣ ΒΟΝΕΣ ΚΑΙ ΕΠΑΤΙ ΒΟΝΩ ΟΤΙ  
 ΟΣΚΑ ΕΡΧΟΡΤΟΣ ΚΑΙ ΠΑΣΑ Η ΔΟΞΑ ΑΥΤΗΣ  
 ΟΣΚΑ ΜΕΣΧΟΡΤΟΥ ΕΞΗΡΑ ΜΟΧΟΡΤΟΣ ΚΑΙ  
 ΤΕ ΜΕΣΕΞΕΠΕΣΕΝ ΤΟ ΔΕΡΗΜΑ ΚΥ ΜΕΝΕΙ  
 ΕΠΙ ΤΗ ΜΑΛΩΝΑ ΚΑΙ ΕΚΕΝ ΕΤΙ ΙΩΑΝΝΗΣ  
 ΒΑΠΤΙΣΤΩ ΚΕΝ ΤΗΡΗΜΩ ΚΑΙ ΚΗΡΥΣΣΗ  
 ΒΑΠΤΙΣΜΑ ΜΕΤΑΝΟΙΑΣ ΕΙΣ ΑΦΕΣΙΝ ΑΜΑΡ  
 ΤΙΩΝ ΚΑΙ ΕΠΙ ΔΟΡΕΥΕΤΟ ΠΡΟΣ ΑΥΤΩΝ ΠΑ  
 ΟΛΩΝ ΟΥ ΕΛΛΑΧΩΡΑ ΚΑΙ Ο ΠΕΡΟΣ ΟΛΥΜΕΤΑ  
 ΚΑΙ ΕΠΙ ΤΙΣ ΟΣΚΟ ΠΑΙΤΕΣ ΕΝ ΤΩ ΠΟΡΑ  
 ΜΗ ΟΥΤΟΥ ΕΞΟΜΟΛΟΓΟΥΜΕΝΟΙ ΤΑΣ ΑΜΑΡ  
 ΤΙΑΣ ΑΥΤΩΝ ΗΝ ΔΕ ΙΩΑΝΝΗΣ ΕΝ ΔΕ ΑΥ  
 ΜΕΝ ΕΡΧΕΤΑΙ ΚΑΜΗΛΟΥ ΚΑΙ ΖΩΗΝ ΚΑΙ ΕΡ  
 ΛΑΖΟΝ ΗΝ ΠΕΡΙ ΤΗΝ ΟΣΦΥ ΚΑΥΤΟΥ  
 ΚΑΙ ΤΗ ΜΕΣΙΩΝΑ ΚΡΕΙΔΑΣ ΚΛΙΜΕΝΙΑ ΤΡΙΩΝ  
 ΚΑΙ ΕΡΧΕΤΑΙ ΕΝ ΔΕ ΙΩΝ ΕΡΧΕΤΑΙ ΟΜΟΤΡΟ  
 ΠΟΣ ΜΟΧΟΓΙΣΩ ΜΟΥ ΟΥ ΟΥ ΚΕΙΜΒΙ ΚΑ  
 ΚΑΙ ΟΚΥ ΦΑΣΧΕ ΑΥΤΟΝ ΠΑΚΤΑ ΤΟΥ ΤΥΠΟ

SECTION OF CODEX WASHINGTONIENSIS (MARK 1:1-7)



Gr NT. It is a complete codex of the Gospels, in a slightly sloping but very ancient hand, written upon good vellum, in one column of 30 lines to the page, and 6x9 in. in size. By all the tests ordi-

Mr. C. L. Freer of Detroit, who obtained the MS in Egypt in 1906, and is edited by Professor H. A. Sanders for the University of Michigan Press, 1911. See accompanying page insert.

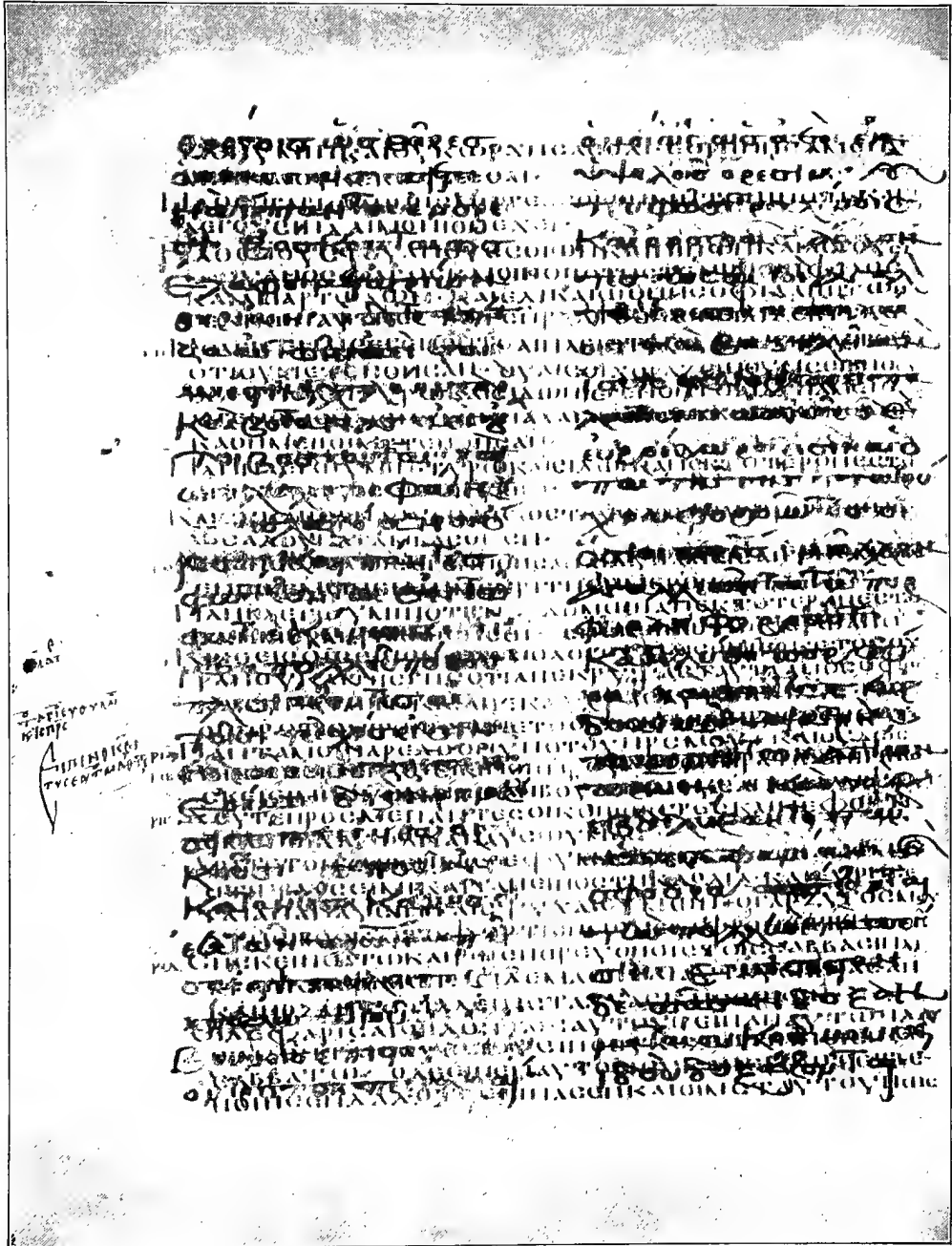

FIG. 2.—FACSIMILE OF COD. EPHRAEMI RESCRIPTUS.

narily given, it belongs to the period of the earliest codices, possibly of the 4th cent. Like Cod. D, it has the order of the Gospels: Mt, Jn, Lk, Mk, and contains an apocryphal interpolation within the longer ending of Mk for which no other Gr authority is known, though it is probably referred to by St. Jerome. It has been published in facsimile by

(2) *Minuscules*.—Out of the thousands of minuscule MSS now known only the four used by Erasmus, together with one now found in the United States, will be enumerated.

1. This is an 11th-cent. codex at Basel. It must have been copied from a good uncial, as its text often agrees with Codd.  $\mathfrak{N}$  and B.

1<sup>r</sup>. Of the 12th cent., and now at Mayhingen, Bavaria. This is the only MS Erasmus had for Rev in his *editio princeps*, and being defective at the end, 22 16-21, he supplied the Gr text by retranslating from the Lat; cf *TR* and AV. Generally speaking, this MS is of high quality.

2. This is a 15th-cent. MS at Basel, and was that on which Erasmus most depended for his 1st ed, 1516. It reflects a good quality of text.

2<sup>p</sup>. Some have assigned this MS to the 12th cent., though it was probably later. It is at Basel, and was the principal text used by Erasmus in the Acts and Epp.

667. As illustrating a good type of minuscule of the Gospels, see Fig. 3, taken from *Evangelistaria* 667, which came from an island of the Sea of Marmora; purchased in Constantinople by Dr. Albert L. Long in 1892 and now in the Drew Seminary Library at Madison, N.J.

Vernacular VSS, or translations of the Scriptures into the tongues of western Christendom, were, some of them, made as early

**5. Vernacular Versions** by several generations our best-known Greek text. It is considered by many as providential that the Bible was early tr<sup>d</sup> into different tongues, so that its corruption to any large extent became almost if not altogether an impossibility, since the VSS of necessity belonged to parts of the church widely removed from one another and with very diverse doctrinal and institutional tendencies.

The testimony of tr<sup>s</sup> to the exact form of words used either in an autograph or a Gr copy of an author is at best not beyond dispute, but as evidence for the presence or absence of whole sections or clauses of the original, their standing is of prime importance. Such extreme literalness frequently prevails that the vernacular idiom is entirely set aside and the order and construction of words in the original sources are slavishly followed and even transliterated, so that their bearing on many questions at issue is direct and convincing. Although the Gr NT has now been tr<sup>d</sup> into all the principal tongues of the earth, comparative criticism is confined to those VSS made during the first eight centuries.

Patristic quotations afford a unique basis of evidence for determining readings of the NT.

**6. Patristic Church Fathers of the early centuries** that it is entirely probable that the whole text of the Gr NT could be recovered from this source alone, if the writings of apologists, homilists and commentators were carefully collated. It is also true that the earliest heretics as well as the defenders of the faith recognized the importance of accurately determining the original text, so that their remains also comprise no mean source for critical research.

It is evident that the value of patristic quotations will vary according to such factors as the reliability of the reading, as quoted, the personal equation or habit of accuracy or looseness of the particular writer, and the purity or corruption of the text he employs. One of the marked advantages of this sort of evidence arises from the fact that it affords additional ground for localizing and dating the various classes of texts found both in original copies and in VSS. For general study the more prominent Church Fathers of the 2d, 3d and 4th cents. are sufficient, though profitable investigation may be made of a much wider period. By the beginning of the 5th cent., however, the type of text quoted almost universally was closely akin to that now known as the *TR*.

Lectionaries and service-books of the early Christian period afford a source of considerable value in determining the general type of texts, together with the order and contents and distribution of the several books of the Canon. As the lectionary systems both of the eastern and western churches reach back to post-apostolic times and all are marked by great verbal conservatism, they present data of real worth for determining certain problems of textual criticism.

**7. Lectionaries and Service-Books**

From the very nature of the case, being compiled for a liturgical use, the readings are often introduced and ended by set formulas, but these are easily separated from the text itself, which generally follows copy faithfully. Even the systems of chapter headings and divisions furnish clues for classifying

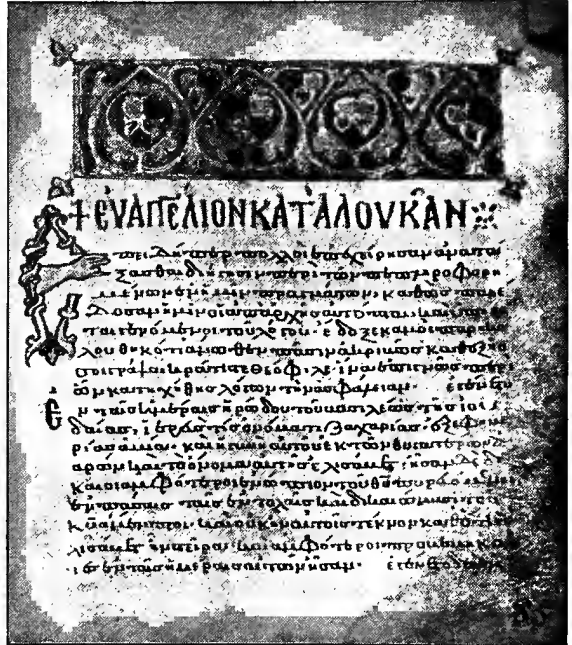

FIG. 3.—Facsimile Minuscule Manuscript.

and comparing texts, for there is high probability that texts with the same chapter divisions come from the same country. Probably the earliest system of chapter divisions is preserved in Cod. Vat., coming down to us from Alexandria probably by way of Caesarea. That it antedates the codex in which it appears is seen from the fact that the Pauline Epp. are numbered as comprising a continuous book with a break between Gal and Eph and the dislocated section numbers attached to He which follows 2 Thess here, though the numbers indicate its earlier position after Gal. Another system of chapter divisions, at least as old as the 5th cent., found in Cod. Alex., cuts the text into much larger sections, known as Cephala Majora. In all cases the enumeration begins with the 2d section, the 1st being considered introductory. Bishop Eusebius developed a system of text division of the Gospels based upon an earlier method attributed to Ammonius, adding a series of tables or Canons. The first table contained sections giving events common to all four evangelists, and its number was written beneath the section number on the margin in each Gospel, so that their parallels could readily be found. The 2d, 3d and 4th Canons con-

tain lists of sections in which three of the Gospels have passages in common (the combination Mk, Lk, Jn, does not occur). The 5th, 6th, 7th, 8th and 9th contain lists in which two combine (the combination Mk, Jn, does not occur). Canon 10 contains those peculiar to some one of the Gospels.

**II. Necessity of Sifting and Criticizing the Evidence.**—Criticism from its very nature concerns itself entirely with the problems suggested by the errors of various kinds which it brings to light. In the writings of the NT the resources of textual evidence are so vast, exceeding, as we have seen, those of any other ancient literature, sacred or secular, that the area of actual error is relatively quite appreciable, though it must be remembered that this very abundance of textual variety ultimately makes for the integrity and doctrinal unity of the teaching of the NT books. Conjectural emendation which has played so large a part in the restoration of other writings has but slight place in the textual criticism of the NT, whose materials are so abundant that the difficulty is rather to select right renderings than to invent them. We have catalogued the principal sources of right readings, but on the most casual investigation of them discover large numbers of wrong readings mingled with the true, and must proceed to consider the sources of error or various readings, as they are called, of which approximately some 200,000 are known to exist in the various MSS, VSS, patristic citations and other data for the text.

"Not," as Dr. Warfield says, "that there are 200,000 places in the NT where various readings occur, but that there are nearly 200,000 readings all told, and in many cases the documents so differ among themselves that many various readings are counted on a single word, for each document is compared in turn with one standard and the number of its divergences ascertained, then these sums are themselves added together and the result given as the number of actually observed variations." Dr. Ezra Abbott was accustomed to remark that "about nineteen-twentieths of the variations have so little support that, although there are various readings, no one would think of them as rival readings, and nineteen-twentieths of the remainder are of so little importance that their adoption or rejection would cause no appreciable difference in the sense of the passages in which they occur." Dr. Hort's view was that "upon about one word in eight, various readings exist supported by sufficient evidence to bid us pause and look at it; about one word in sixty has various readings upon it supported by such evidence as to render our decision nice and difficult, but that so many variations are trivial that only about one word in every thousand has upon it substantial variation supported by such evidence as to call out the efforts of the critic in deciding between the readings." The oft-repeated dictum of Bentley is still valid that "the real text of the sacred writings is competently exact, nor is one article of faith or moral precept either perverted or lost, choose as awkwardly as you will, choose the worst by design, out of the whole lump of readings." Despite all this, the true scholar must be furnished rightly to discriminate in the matter of diverse readings.

From the very nature of the case it is probable that errors should be frequent in the NT; indeed, even printed works are not free from them, as is seen in the most carefully edited editions of the Eng. Bible, but in MSS the difficulty is increased in direct proportion to the number of various copies still extant. There are two classes of errors giving rise to various readings, unconscious or unintentional and conscious or intentional.

Of the first class, that of unconscious errors, there are five sorts:

(1) *Errors of the eye*, where the sight of the copyist confuses letters or endings that are similar, writing e.g.  $\epsilon$  for  $C$ ;  $O$  for  $\Theta$ ;  $A$  for  $\Lambda$  or  $\Delta$ ;  $\Pi$  for  $T$ ;  $\Pi\Lambda$  for  $T\Lambda$ ;  $M$  for  $\Lambda\Lambda$ . Here should be named *homoeoteleuton*, which arises when two successive lines in a copy end in the same word or syllable and the eye catches the second line instead of the first and the copyist omits the intervening words as in Cod. C of Jn 6 39.

(2) *Errors of the pen*.—Here is classed all that body of variation due to the miswriting by the penman of

what is correctly enough in his mind but through carelessness he fails rightly to transfer to the new copy. Transposition of similar letters has evidently occurred in Codd. E, M, and H of Mk 14 65, also in  $H_2L_2$  of Acts 13 23.

(3) *Errors of speech*.—Here are included those variations which have sprung from the habitual forms of speech to which the scribe in the particular case was accustomed and which he therefore was inclined to write. Under this head comes "Itacism," arising from the confusion of vowels and diphthongs, esp. in dictation. Thus  $\iota$  is constantly written  $\epsilon$  and vice versa;  $\alpha$  for  $\epsilon$ ;  $\eta$  and  $\iota$  for  $\epsilon$ ;  $\eta$  and  $\alpha$  for  $\nu$ ;  $\omega$  for  $\omega$  and  $\epsilon$  for  $\eta$ . It is observed that in Cod.  $\mathcal{S}$  we have scribal preference for  $\iota$  alone, while in B  $\epsilon$  is preferred.

(4) *Errors of memory*.—These are explained as having arisen from the "copyist holding a clause or sequence of letters in his somewhat treacherous memory between the glance at the MS to be copied and his writing down what he saw there." Here are classed the numerous petty changes in the order of words and the substitution of synonyms, as  $\epsilon\lambda\epsilon\upsilon\theta$  for  $\epsilon\phi\eta$ ,  $\epsilon\kappa$  for  $\alpha\pi\acute{o}$ , and vice versa.

(5) *Errors of judgment*.—Under this class Dr. Warfield cites "many misreadings of abbreviations, as also the adoption of marginal glosses into the text by which much of the most striking corruption which has entered the text has been produced." Notable instances of this type of error are found in Jn 5 1-4, explaining how it happened that the waters of Bethesda were healing; and in Jn 7 53-8 12, the passage concerning the adulteress, and the last twelve verses of Mt.

Turning to the second class, that of conscious or intentional errors, we may tabulate:

(1) *Linguistic or rhetorical corrections*, no doubt often made in entire good faith under the impression that an error had previously crept into the text and needed correcting. Thus second aorist terminations in  $\alpha$  are changed to  $\circ$  and  $\theta$  to  $\lambda$ .

(2) *Historical corrections*.—Under this head is placed all that group of changes similar to the case in Mk 1 2, where the phrase "Isaiah the prophet" is changed into "the prophets."

(3) *Harmonistic corrections*.—These are quite frequent in the Gospels, e.g. the attempted assimilation of the Lord's Prayer in Lk to the fuller form in Mt, and quite possibly the addition of the words "of sin" to the phrase in Jn 8 34, "Every one that doeth sin is a slave." A certain group of harmonistic corruptions where scribes allow the memory, perhaps unconsciously, to affect the writing may rightly be classed under (4) above.

(4) *Doctrinal corrections*.—Of these it is difficult to assert any unquestioned cases unless it be the celebrated Trinitarian passage (AV 1 Jn 5 7.8a) or the several passages in which fasting is coupled with prayer, as in Mt 17 21; Mk 9 29; Acts 10 30; 1 Cor 7 5.

(5) *Liturgical corrections*.—These are very common, esp. in the lectionaries, as in the beginning of lessons, and are even found in early uncials, e.g. Lk 8 31; 10 23, etc.

**III. Methods of Critical Procedure.**—Here as in other human disciplines necessity is the mother of invention, and the principles of critical procedure rest almost entirely on the data connected with the errors and discrepancies which have consciously or unconsciously crept into the text. The dictum of Dr. George Salmon that "God has at no time given His church a text absolutely free from ambiguity" is true warrant for a free and continued inquiry into this attractive field of study. The process of textual criticism has gradually evolved certain rules based upon judgments formed after patiently classifying and taking into account all the documentary evidence available, both internal and external.

(1) An older reading is preferable to one later, since it is presumed to be nearer the original. However, mere age is no sure proof of purity, as it is now clear that very many of the corruptions of the text became current at an early date, so that in some cases it is found that later copies really represent a more ancient reading.

(2) A more difficult reading, if well supported, is preferable to one that is easier, since it is the tendency of copyists to substitute an easy, well-known and smooth reading for one that is harsh, unusual and ungrammatical. This was commonly done with the best of intentions, the scribe supposing he was rendering a real service to truth.

(3) A shorter is preferable to a longer reading, since here again the common tendency of scribes is toward additions and insertions rather than omis-

sions. Hence arose, in the first place, the marginal glosses and insertions between the lines which later transcribers incorporated into the text. Although this rule has been widely accepted, it must be applied with discrimination, a longer reading being in some cases clearly more in harmony with the style of the original, or the shorter having arisen from a case of homeoteleuton.

(4) A reading is preferable, other things being equal, from which the origin of all alternative readings can most clearly be derived. This principle is at once of the utmost importance and at the same time demands the most careful application. It is a sharp two-edged sword, dangerous alike to the user and to his opponents.

(5) A reading is preferable, says Scrivener, "which best suits the peculiar style, manner and habits of thought of an author, it being the tendency of copyists to overlook the idiosyncrasies of the writer. Yet habit or the love of critical correction may sometimes lead the scribe to change the text to his author's more usual style as well as to depart from it through inadvertence, so that we may securely apply the rule only where the external evidence is not unequally balanced."

(6) A reading is preferable which reflects no doctrinal bias, whether orthodox on the one side or heretical on the other. This principle is so obvious that it is accepted on all sides, but in practice wide divergence arises, owing to the doctrinal bias of the critic himself.

These are the main Canons of internal evidence. On the side of external evidence may be summarized what has already been implied:

(1) A more ancient reading is usually one that is supported by the most ancient MSS.

(2) A reading which has the undoubted support of the earliest MSS, VSS and patristic writers is unquestionably original.

(3) A disagreement of early authorities usually indicates the existence of corruption prior to them all.

(4) Mere numerical preponderance of witnesses (to a reading) of any one class, locality or time, is of comparative insignificance.

(5) Great significance must be granted to the testimony of witnesses from localities or times widely apart, and it can only be satisfactorily met by a balancing agreement of witnesses also from different times and localities.

These rules, though they are all excellent and each has been employed by different critics with good results, are now somewhat displaced, or rather supplemented, by the application of a principle very widely used, though not discovered, by Westcott and Hort, known as the principle of the genealogy of MSS. The inspection of a very broad range of witnesses to the NT text has led to their classification into groups and families according to their prevailing errors, it being obvious that the greater the community of errors the closer the relationship of witnesses. Although some of the terms used by WH, as well as their content, have given rise to well-placed criticism, yet their grouping of MSS is so self-convincing that it bids fair, with but slight modification, to hold, as it has thus far done, first place in the field. Sir Frederick G. Kenyon has so admirably stated the method that the gist of his account will be given, largely using his identical words (*Handbook to the Textual Criticism of the NT*, 2d ed, London, 1912). As in all scientific criticism, four steps are followed by WH: (a) The individual readings and the authorities for them are studied; (b) an estimate is formed of the character of the several authorities; (c) an effort is made to group these authorities as descendants of a common ancestor, and (d) the individual readings are again taken up and the first

provisional estimate of their comparative probability revised in the light of the knowledge gained as to the value and interrelation of the several authorities.

Applying these methods, four groups of texts emerge from the mass of early witnesses: (a) The Antiochian or Syrian, the most popular of all and at the base of the Greek *TR* and the English *AV*; in the Gospels the great uncials *A* and *C* support it as well as *N*, *Σ* and *Φ*, most of the later uncials and almost all minuscules, the Pesh-Syr version and the bulk of the Church Fathers from Chrysostom; (b) the Neutral, a term giving rise to criticism on all sides and by some displaced by the term Egyptian; this group is small but of high antiquity, including *NB LT Z*, *A* and *C*, save in the Gospels, the Coptic *VSS* (esp. the Bohairic) and some of the minuscules, notably 33 and 81; (c) the Alexandrian, closely akin to the Neutral group, not found wholly in any one MS but traceable in such MSS as *N CLX*, 33, and the Bohairic version, when they differ from the other members headed by *B*; (d) the Western, another term considered ambiguous, since it includes some important MSS and Fathers very ancient and very Eastern; here belong *DD<sup>2</sup> E<sup>2</sup>F<sup>2</sup>G<sup>2</sup>* among the uncials, 28, 235, 383, 565, 614, 700, and 876 among the minuscules, the Old Syr and Old Lat and sometimes the Sahidic *VSS*.

Of these groups by far the most superior is the Neutral, though WH have made it so exclusively to coincide with Cod. B that they appear at times to have broken one of the great commandments of a philologist, as quoted by Dr. Nestle from a German professor, "Thou shalt worship no codices." Now, the only serious dispute centers on the apparent slight which this system may have put upon the so-called Western type of text in group four. The variants of this family are extensive and important and appear due to an extremely free handling of the text at some early date when scribes felt themselves at liberty to vary the language of the sacred books and even to insert additional passages of considerable length.

Although this type of text is of very early origin and though prevalent in the East was very early carried to the West, and being widely known there has been called Western, yet, because of the liberties above referred to, its critical value is not high, save in the one field of omissions. In Egypt, however, and esp. Alexandria, just as in the case of the OT, the text of the NT was critically considered and conserved, and doubtless the family called Neutral, as well as the so-called Alexandrian, springs up here and through close association with Caesarea becomes prevalent in Pal and is destined to prevail everywhere. The WH contention that the Antiochian text arose as a formal attempt at repeated revision of the original text in Antioch is not so convincing, but for want of a better theory still holds its place. Their objections, however, to its characteristic readings are well taken and everywhere accepted, even von Soden practically agreeing here, though naming it the *koinē* text. It is also interesting to find that von Soden's Hesyehian text so closely parallels the Neutral-Alexandrian above, and his Jerusalem family the Western. And thus we arrive at the present consensus of opinion as to the genealogical source of the text of the NT.

**IV. History of the Process.**—Abundant evidence exists and is constantly growing to show that critical opinion and methods were known at least from the very days of the formation of the NT Canon, but in such a sketch as the present the history can only be traced in modern times. The era of printing necessarily marks a new epoch here. Among available MSS choice must be made and a standard set, and in view of the material at hand it is remarkable



how ably the work was done. It began in Spain under Cardinal Ximenes of Toledo, who printed at Alcalá (Complutum) in 1514 the NT volume of his great Polyglot, though it was not actually issued until 1522. Meanwhile the great Erasmus, under patronage of Froben the printer of Basel, had been preparing a Gr NT, and it was published early in 1516 in a single volume and at low cost, and had reached its 3d ed by 1522. His 4th ed in 1537 contains Erasmus' definitive text, and, besides using Cardinal Ximenes', had the advantage of minuscule MSS already named. The next important step was taken by Robert Estienne (Stephanus), whose 3d ed, "Regia," a folio published in Paris in 1550, was a distinct advance, and, though based directly upon the work of Ximenes and Erasmus, had marginal readings from 15 new MSS, one of which was Cod. Bezae (D). The learned Theodore Beza himself worked with Stephanus' son Henri, and brought out no less than nine editions of the NT, but no great critical advance was made in them. The same may be said of the seven Elzevir editions brought out at Leyden and Amsterdam between 1624 and 1678, the second, that of 1633, in the preface of which occurs the phrase, "Textum ergo habes nunc ab omnibus receptum," becoming the continental standard, as the 1550 edition of Stephanus has for England. Thus we arrive at the TR, and the period of preparation is closed.

The second period, or that of discovery and research, was ushered in by the great *London Polyglot* of 1657, edited by Brian Walton (later Bishop of Chester) with collations by Archbishop Ussher of 15 fresh MSS, including Cod. A and Cod. 59. But Dr. John Mill of Oxford was the Erasmus of this period, and in 1707 after 30 years of labor brought out the Gr TR with fresh collations of 78 MSS, many VSS and quotations from the early Fathers. His MSS included A B D E K, 28, 33, 59, 69, 71, the Peshito, Old Lat and Vulg, and his *Prolegomena* set a new standard for textual criticism. This apparatus was rightly appreciated by Richard Bentley of Cambridge and a revised text of the Gr and of the Vulg NT was projected along lines which have prevailed to this day. The work and wide correspondence of Bentley had stirred up continental scholars, and J. A. Bengel published in 1734 at Tübingen a Gr NT with the first suggestion as to genealogical classification of MSS. J. J. Wetstein of Basel and Amsterdam, though a very great collector of data and the author of the system of MS notation which has continued ever since, made little critical advance. J. S. Semler, taking Wetstein's material, began rightly to interpret it, and his pupil J. J. Griesbach carried the work still farther, clearly distinguishing for the first time a Western, an Alexandrian and a Constantinopolitan recension.

With Carl Lachmann began the last epoch in NT criticism which has succeeded in going behind the TR and establishing an authentic text based on the most ancient sources. He applied the critical methods with which he was familiar in editing the classics, and with the help of P. Buttmann produced an edition in 1842-50 which led the way directly toward the goal; but they were limited in materials and Tischendorf soon furnished these. Constantin Tischendorf, both as collector and editor, is the foremost man thus far in the field. His 8th ed, 1872, of the Gr NT, together with his *Prolegomena*, completed and published, 1884-1894, by C. R. Gregory, set a new standard. Dr. Gregory's German edition of the *Prolegomena*, 1900-1909, supplemented by his *Die griechischen Handschriften des NT*, 1908, marks the further advance of the master through his master pupil. Meanwhile, S. P. Tregelles was doing almost as prodigious and

valuable a work in England, and was thus preparing for the final advances at Cambridge. F. H. A. Scrivener also ranks high and did extremely valuable, though somewhat conservative, work in the same direction. In 1881 "the greatest edition ever published," according to Professor Souter, was brought out in England coincident with the RV of the Eng. NT. This, together with the introduction, which the same writer characterizes as "an achievement never surpassed in the scholarship of any country," was the joint product of B. F. Westcott and F. J. A. Hort, friends and co-workers for many years in the University of Cambridge. Thus with the end of the 19th cent. the history of the process may be said to close, though both process and progress still advance with ever-increasing triumph.

Von Soden's ed of the NT appeared during the summer of 1913 and is of first importance. It differs from all others in the extreme weight laid on Tatian's *Diatessaron* as the source of the bulk of the errors in the Gospels. This theory is not likely to command the assent of scholars and the text (which does not differ greatly from Tischendorf's) is consequently of doubtful value. Nevertheless, for fulness of material, clearness of arrangement, and beauty of printing, von Soden's ed must inevitably supersede all others, even where the text is dissented from. Dr. Gregory promises a new ed at some day not too far in the future which, in turn, will probably supersede von Soden's.

LITERATURE.—C. R. Gregory, *Prolegomena to Tischendorf's NT*, Leipzig, 1884-94; *Textkritik des NT*, Leipzig, 1900-1909; *Die griechischen Handschriften des NT*, Leipzig, 1908; *Einleitung in das NT*, Leipzig, 1909; *Vorschläge für eine kritische Ausgabe des griechischen NT*, Leipzig, 1911; F. G. Kenyon, *Palaeography of Gr Papyri*, Oxford, 1899; *Handbook to the Textual Criticism of the NT*, London<sup>2</sup>, 1912; K. Lake, *The Text of the NT*, 4th ed, London, 1910; G. Milligan, *Selections from the Gr Papyri*, Cambridge, 1910; *The NT Documents*, 1913; Eb. Nestle, *Einführung in das NT*, Göttingen<sup>2</sup>, 1909; F. H. A. Scrivener, *Plain Introduction to the Criticism of the NT*, 4th ed, London, 1894; Souter, *Text and Canon of the NT*, 1913; E. M. Thompson, *Handbook of Gr and Lat Palaeography*, 2d ed, London, 1894; H. von Soden, *Die Schriften des NT*, I. Teil, Untersuchungen, Berlin, 1902-10; II. Teil, 1913; B. F. Westcott, and F. J. A. Hort, *The NT in Gr with Introduction*, Cambridge and London, 1896; Th. Zahn, *Intro to the NT*, ET, Edinburgh, 1910.

CHARLES FREMONT SITTERLY

#### TEXT OF THE OLD TESTAMENT:

- I. EARLIEST FORM OF WRITING IN ISRAEL
  1. Invention of Alphabet
  2. The Cuneiform
  3. References to Writing in the OT
  4. Inscriptions after Settlement in Canaan
  5. Orthography of the Period
- II. THE TWO HEBREW SCRIPTS
  1. The Old Hebrew Alphabet
  2. Aramaean Alphabets
  3. The New Hebrew Script
  4. New Hebrew Inscriptions
  5. Summary
- III. THE CHANGE OF SCRIPT
  1. Various Theories
  2. The Change in the Law
  3. In the Other Books
  4. Evidence of the LXX
  5. Evidence of the Text Itself
  6. Conclusion
- IV. PRESERVATION OF THE TEXT
  1. Internal Conditions
  2. External Circumstances
  3. The LXX Version
- V. THE TEXT IN THE 1ST CENTURY AD
  1. Word Separation
  2. Other Breaks in the Text
  3. Final Forms of Letters
  4. Their Origin
  5. Conclusion
  6. The Vowel-Letters
  7. Anomalous Forms
  8. The Dotted Words
  9. Their Antiquity
  10. The Inverted *nūns*
  11. Large and Small Letters
  12. Suspended Letters and Divided *wāw*
  13. Abbreviations
  14. Conclusion

- VI. ALTERATION OF PRINCIPAL DOCUMENTS
1. Jehovah and Baal
  2. Euphemistic Expressions
  3. *Tikkūn sopherim*
- VII. SCRIBAL ERRORS IN THE TEXT
1. Misunderstanding
  2. Errors of the Eye
  3. Errors of the Ear
  4. Errors of Memory
  5. Errors of Carelessness and Ignorance
- VIII. HISTORY OF THE TEXT
1. Changes Made in Reading
  2. Preservation of Text
  3. Division into Verses
  4. Sections of the Law
  5. Sections of the Prophets
  6. Poetical Passages
  7. Division into Books
- IX. VOCALIZATION OF THE TEXT
1. Antiquity of the Points
  2. Probable Date of Invention
  3. Various Systems and Recensions
- X. THE PALESTINIAN SYSTEM
1. The Consonants
  2. The Vowels
  3. The Accents
  4. Anomalous Pointings
- XI. THE MASORAH
1. Meaning of the Term
  2. The K<sup>r</sup>e and K<sup>t</sup>hibh
  3. Other Features
- XII. MSS AND PRINTED TEXTS
1. Manuscripts
  2. Early Printed Texts
  3. Later Editions
  4. Chapters and Verses

## LITERATURE

**I. Earliest Form of Writing in Israel.**—The art of writing is not referred to in the Book of Gen, even where we might expect a reference to it, e.g. in Gen 23, nor anywhere in the OT before the time of Moses (cf, however, Gen 38 18.25; 41 44, which speak of "sealing" devices, and see SEAL; WRITING).

About the year 1500 BC alphabetic writing was practised by the Phoenicians, but in Pal the syllabic Bab cuneiform was in use (see 1. Invention ALPHABET). The Israelites probably of Alphabet did not employ any form of writing in their nomadic state, and when they entered Canaan the only script they seem ever to have used was the Phoen. This is not disproved by the discovery there of two cuneiform contracts of the 7th cent., as these probably belonged to strangers. There is only one alphabet in the world, which has taken many forms to suit the languages for which it was employed. This original alphabet was the invention of the Semites, for it has letters peculiar to the Semitic languages, and probably of the Phoenicians (so Lucan, *Pharsalia* iii.220; of Herod. v.58), who evolved it from the Egyp hieroglyphics.

Of the lit. of Canaan before the Israelites entered it the remains consist of a number of cuneiform tablets found since 1892 at Lachish, 2. The Gezer, Taanach and Megiddo, but Cuneiform esp. of the famous Am Tab, discovered in Egypt in 1887. Although this non-alphabetic script was in use in Canaan when the Israelites entered it, they do not seem to have adopted it.

The earliest reference to writing in the OT is Ex 17 14. The next is Ex 24 7, mentioning the Book of the Covenant (Ex 20-23). 3. Refer- The Book of the Wars of Jeh is named ences to are Jgs 5 14 m; 8 14 m. By the time Writing in the OT of the monarchy the king and nobles could write (2 S 11 14; 8 17), but not the common people, until the time of Amos and Hosea, when writing seems to have been common.

The Phoen script prevailed in Pal after the conquest as well as in the countries bordering on it. This is shown by the inscriptions which have been discovered. The chief of these are: the Baal

Lebanon inscription found in Cyprus (beginning of the 9th cent.); the MS of about the year 896 of the ordinary chronology; a Heb agricultural calendar of the 8th cent.; fifteen lion-weights from Nineveh of about the year 700; the Siloam Inscription of the time of Hezekiah; about a score of seals; and, in 1911, a large number of ostraca of the time of Ahab.

In this oldest writing the vowels are rarely expressed, not even final vowels being indicated.

The only mark besides the letters is a 5. Orthog- point separating the words. There raphy of the are no special forms for final letters. Period Words are often divided at the ends of lines. The writing is from right to left. The characters of the Siloam Inscription and the ostraca show some attempt at elegant writing.

**II. The Two Hebrew Scripts.**—Two distinct scripts were used by the Hebrews, an earlier and a later. The Old Heb alphabet contained 22 letters, all consonants. The

1. The Old Hebrew order of these letters is known from Alphabet that of the Gr, taken in order of their numerical values, and later by the alphabetic pss, etc, and by the figure called 'at-bash (see SHESHACH). In the acrostic passages, however, the order is not always the same; this may be due to corruption of the text. In the alphabet, letters standing together bear similar names. These are ancient, being the same in Gr as in Sem. They were probably given from some fancied resemblance which the Phoenicians saw in the original Egyp sign to some object.

The development of the Phoen alphabet called Aram. begins about the 7th cent. BC. It is found inscribed as docketts on the cuneiform 2. Ara- clay tablets of Nineveh, as the Phoen maeon letters were upon the lion-weights; Alphabets on coins of the Pers satraps to the time of Alexander; on Egyp inscriptions and papyri; and on the Palmyrene inscriptions. The features of this script are the following: The loops of the letters *bēth*, *dāleth*, *tēth*, *kōph* and *rēsh*, which are closed in the Phoen and Old Heb, are open, the bars of the letters *hē*, *wāw*, *zayin*, *hēth* and *tāw* are lost, and the tails of *kaph*, *lamedh*, *mēm*, *pē* and *qādhe*, which are vertical in the old Aram., begin in the Egyp Aram. to curve toward the left; words are divided, except in Palmyrene, by a space instead of a point; vowel-letters are freely used; and the use of ligatures involves a distinction of initial, medial and final forms. There are of course no vowel-marks.

After the Jews returned from the exile, the Aram. language was the *lingua franca* of the Seleucid empire, displacing Assyri, Old Heb and 3. The Phoen. The Phoen script also had New He- given place to the Aram. in Mesopo- brew Script tania, Syria and Egypt. In Syria it divided into two branches, a northern which grew into Syriac, and a southern, or Jewish, from which the New Heb character was produced.

What is believed to be the oldest inscription in the modern Heb character is that in a cave at 'Araḥ al-'Amīr near Heshbon, which 4. New was used as a place of retreat in the Hebrew In- year 176 BC (*Ant.*, XII, iv, 11; *CIH*, scriptions no. 1). Others are: four boundary stones found at Gezer; the inscriptions over the "Tomb of St. James," really of the Beni Hezir (1 Ch 24 15; Neh 10 20); that of Kefr Birim, assigned to the year 300 AD (*CIH*, no. 17), in which the transition to the New Heb script may be said to be accomplished; and others have been

found all over the Rom empire and beyond. See ARCHAEOLOGY.

The inscriptions show that the familiar Heb character is a branch of the Aramaic. In the 3d cent.

BC the latter script was in general use in those countries where Assyrian, Old Heb and Phoen had been used before.

The Jews, however, continued to employ the Old Heb for religious purposes esp., and the Samaritans still retain a form of it in their Bible (the Pent).

III. The Change of Script.—It is now almost universally agreed that the script in which the OT was written was at some time changed from the Phoenician to the Aramaic. But in the past many opinions have been held on the subject.

Rabbi Eleazar of Modin (d. 135 AD), from the mention of the hooks (wāws) in Ex 27 10 and from Est 8 9, denied any

1. Various change at all. Rabbi Jehuda Theories (d. c 210) maintained that the Law was given in the New Heb,

which was later changed to the Old as a punishment, and then back to the New, on the people repenting in the time of Ezra. Texts bearing on the matter are 2 K 5 7; 18 26; Isa 8 1, from which various deductions have been drawn. There may have been two scripts in use at the same time, as in Egypt (Herod. ii.36).

In regard to the change in the Law, the oldest authority, Eleazar ben Jacob (latter part of the 1st cent. AD), declared that a Prophet

2. Change at the time of the Return commanded in the Law to write the Torah in the new or square character. Next Rabbi Jose (a

century later) states (after Ezr 4 7) that Ezra introduced a new script and language. But the locus classicus is a passage in the Talm (Sanhedrin 21b): "Originally the Law was given to Israel in the Heb character and in the Holy Tongue; it was given again to them in the days of Ezra in the Assyrian characters and in the Aram. tongue to the hedhyōtōth." Here Heb=Old Hebrew; Assyrian=the new square character, and hedhyōtōth is the Gr idōtōtai=the Heb 'am hā-āreç, the illiterate multitude. From the 2d cent. on (but not before), the Talmudic tradition is unanimous in ascribing the change of script in the Law to Ezra. The testimony of Jos points to the Law at least being in the square character in his day (Ant, XII, ii, 1, 4). The Sam Pent was almost certainly drawn up in the time of Nehemiah (cf 13 28; also Ant, XI, vii, 2), and points to the Old Heb being then in use. So Rabbi Hasda (d. 309) refers to the word hedhyōtōth above to the Samaritans. On the other hand, the Sam Pent may have been the original Law, common to both Israel and Judah. In any case it is written in a form of the Old Heb character.

In regard to the other books, the old script was used after Ezra's time. Est 8 9 and Dnl 5 8 ff must refer to the unfamiliar Old Heb.

3. Other So Mt 5 18 implies the New, but only Books in the Law.

The Gr tr known as the LXX was made in Alexandria, and is hardly evidence for Pal. The Law was probably tr<sup>d</sup> under Ptolemy II (284-247 BC), and the other books by the

4. Evidence end of the 2d cent. BC (cf Ecclus, of LXX Prologue). The variations of the LXX

from the MT point to an early form of the square character as being in use; but the Jews of Egypt had used Aram. for some centuries before that.

The variations between parallel passages in the

MT itself, such as Josh 21 and 1 Ch 6; 2 S 23 and 1 Ch 11, etc, show that the letters most frequently confused are d and r, which are similar in both the Old and New Heb; b and d, which are more alike in the Old; w and y and several others, which are more alike in the New. Such errors evidently

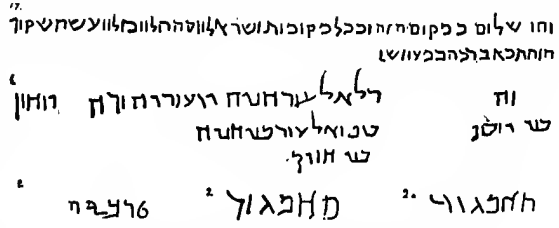

New Hebrew Inscriptions.

1. From cave near Heshbon, reads: 'Arabiah—the first letter is still in the old character. 2. a. Boundary stones of Gezer, read: T h m G z r, limit of Gezer—beginning of Christian era. 6. Tomb of the Beni Hēzir, reads: This (is the grave) of Eleazar, Hannahah, Judah . . . . Johannan, sons of Joseph . . . . (Joseph and Eleazar, sons of Hannahah . . . . sons of Hēzir. 17. Inscription of Kefr Birim, reads: Peace be unto this place and upon all the places of Israel. Josiah the Levite, son of Levi, made this lintel: may blessing come upon his works.

arose from the use of the square character, and they arose subsequent to the LXX, for they are not, except rarely, found in it. The

5. Evidence square character is, then, later than of the Text the LXX.

Itself The square character was ascribed to Ezra as the last person who could have made so great a change, the text after his time being considered sacred. This is disproved

6. Conclu- by the fact of the coins of the Maccabees and of Bar Cochba being in the old character. The Talm permits

sion Jews resident outside Pal to possess copies of the Law in Coptic, Median, Heb, etc. Here Heb can only mean the Old Heb script.

IV. Preservation of the Text.—Judaism has always been a book religion: it stands or falls with the OT, esp. with the Pent. Although

1. Internal no MS of the Heb OT is older than the Conditions 10th cent. AD, save for one minute

papyrus, we know, from citations, tr<sup>s</sup>, etc, that the consonantal text of the OT was in the 1st cent. AD practically what it is today. The Jews transliterated as well as tr<sup>d</sup> their Bible. All the most important tr<sup>s</sup>—the LXX, Aquila, Theodotion, Symmachus—were made by Jews and aimed at a more literal rendering of the Heb—that of Aquila being hardly Gr. The Syr (Peshitta) seems to be also by Jews or Jewish Christians. Great care was taken of the text itself, and the slightest variant readings of MSS were noted. One MS belonging to Rabbi Meir (2d cent.) is said to have omitted the references to "Admah and Zebaoim" in Dt 29 23 and to Bethlehem in Gen 48 7, and to have had other lesser variations, some of which were found also in the MS which, among other treasures, decked the triumph of Vespasian (BJ, VII, v, 7).

Religious persecution makes for the purity of the Scriptures by reducing the number of copies and increasing the care bestowed on those

2. External saved. The chief moments in which Circum- the existence of the Jewish Scriptures stances was threatened were the destruction

of Jerus and the Temple under Nebuchadnezzar in 587 BC, in which the Book of Jashar and that of the Wars of the Lord may have been lost; the persecution under Antiochus Epiphanes, during which the possession of the sacred books was a capital offence (1 Macc 1 56.57; Ant, XII, v), in which the sources used by the Chronicler may have perished; and the capture of Jerus by Titus

in 70 AD. By this time, however, the Law at least was known by heart. Jos says Titus made him a gift of the sacred books (*Vita*, 75). It is also said that at one time only three copies of the Law were left, and that a text was obtained by taking the readings of two against one. However that may be, it is a fact that there are no variant readings in the MT, such as there are in the NT.

The only ancient version which can come into competition with the MT is the LXX, and that on two grounds. First, the MSS of the

### 3. The LXX Version

LXX are of the 4th cent. AD, those of the MT of the 10th. Secondly, the LXX tr was made before a uniform Heb text, such as our MT, existed. The quotations in the NT are mainly from the LXX. Only in the Book of Jer, however, are the variations striking, and there they do not greatly affect the sense of individual passages. The Gr has also the Apoc. The LXX is an invaluable aid to restoring the Heb where the latter is corrupt.

**V. The Text in the 1st Century AD.**—The MT of the 1st Christian cent. consisted solely of consonants of an early form of the square character. There was no division into chapters or, probably, verses, but words were separated by an interstice, as well as indicated by the final letters. The four vowel-letters were used most freely in the later books. A few words were marked by the scribes with dots placed over them.

The Sam Pent still employs the point found on the M S to separate words. This point was probably dropped when the books came to

### 1. Word Separation

Wrong division of words was not uncommon.

Tradition mentions 15 passages noted on the margin of the Heb Bible (Gen 30 11, etc) in which two words are written as one. One word is written as two in Jgs 16 25; 1 S 9 1, etc. Other passages in which tradition and text differ as to the word-division are 2 S 5 2; Ezk 42 9; Job 38 12; Ezr 4 12. The LXX frequently groups the letters differently from the MT, e.g. (see the comms.) Hos 11 2; 1 Ch 17 10; Ps 73 4; 106 7.

The verse-division is not shown in the prose books. The present division is frequently wrong and the LXX different from the Heb; e.g. Gen 49 19, 20; Ps 42 6, 7; Jer 9 5, 6; Ps 90 2, 3.

### 2. Other Breaks in the Text

Neither was there any division into chapters, or even books. Hence the number of the pss is doubtful. The Gr counts Pss 9 and 10 as one, and also Pss 114 and 115, at the same time splitting Pss 116 and 147 each into two. The Syr follows the Gr with regard to Pss 114 and 147. Some MSS make one ps of 42 and 43. In Acts 13 33, Cod. Bezae, Ps 2 appears as Ps 1.

Final forms of letters are a result of the employment of ligatures. In the Old Heb they do not occur, nor apparently in the text used

### 3. Final Forms of Letters

by the LXX. Ligatures begin to make their appearance in Egypt, Aram. and Palmyrene. Final forms for the letters *k*, *m*, *n*, *p*, *ç*, were accepted by the 1st cent., and all other final forms were apparently rejected.

The first rabbi to mention the final forms is Mathiah ben Harash (a pupil of Rabbi Eleazar who died in 117 AD), who refers them to Moses. They are often referred to in the Talm and by Jerome.

### 4. Their Origin

The Sam Chronicle (11th cent.) refers them to Ezra. In point of fact, they are not so old as the LXX tr, as is proved by its variations in such passages as 1 S 1 1; 20 40; Ps 16 3; 44 5; Jer 16 19; 23 14, 23, 33; Hos 6 5; Nah 1 12; Zec 11 11; Ecclus 3 7. From the fact that the final forms make up the Heb expression for "from thy watchers," their invention was referred in the 3d cent. to the prophets (cf Isa 52 8; Hab 2 1).

After the adoption of the square character, therefore, the only breaks in the text of prose books were the spaces left between the words. Before the 1st cent. there was much uncertainty as to the grouping of the letters into words.

After that the word-division was retained in the copies, even when it was not read (as in 2 S 5 2, etc). At first the final form would occur at the end of the ligature, not necessarily at the end of the word. Remains of this will be found in 1 Ch 27 12; Isa 9 6; Neh 2 13; Job 38 1; 40 6. When the ligatures were discarded, these forms were used to mark the ends of words. The wonder is that there are not more, or even an initial, medial and final form for every letter, as in Arab. and Syriac.

The four letters, *h*, *v*, *y*, seem to have been used to represent vowel sounds from the first. They are found in the MSS, but naturally less freely on stone inscriptions than in books. The later the text the more freely they occur, though they are commoner in the Sam Pent than in the MT. The copies used by the LXX had fewer of them than the TR, as is proved by their tr<sup>s</sup> of Am 9 12; Ezk 32 29; Hos 12 12, and other passages. The four letters occur on Jewish coins of the 2d cent. BC and AD.

### 6. Vowel-Letters

In the 1st and 2d cents. the vowel-letters were retained in the text, even when not read (Hos 4 6; Mic 3 2, etc). In the Pent, Dt 32 13 seems to be the sole instance. The Pent is peculiar also in that in it the 3d person sing., masc., of the personal pronoun is used for the fem., which occurs only 11 t; Gen 2 12; 14 2; cf Isa 30 33; 1 K 17 15; Job 31 11. This phenomenon probably arises from the stage in the growth of the script when *wāw* and *yōdh* were identical in form; cf Ps 73 16; Eccl 5 8. Frequently the 1st person sing. perf. of the vb. is written defectively (Ps 140 13; 2 K 18 20; cf Isa 36 5); similarly the *h* of *na'ārāh* (Dt 22). All this shows there was no attempt to correct the text. It was left as it was found.

When a scribe had miscopied a word he sometimes placed dots over it, without striking it out. There are 15 passages 'o marked in the OT, and the word *nākhūh*, "pointed," is generally placed in the margin. The word may also be read *nākhōh*, "speckled" (Gen 30 32), or *nikkūdh*, "punctuation." It is also possible that these points may denote that the word is doubtful. They occur in the following places: Gen 16 5; 18 9; 19 33; 33 4; 37 12; Nu 3 39; 9 10; 21 30; 29 15; Dt 29 28 (29); Ps 27 13; 2 S 19 20; Isa 44 9; Ezk 41 20; 46 22. For conjectures as to the meanings of the points in each passage, the reader must be referred to the commentaries.

These points are found even on synagogue rolls which have, with one exception, no other marks upon them, beyond the bare consonants and vowel-letters. Only those in the Pent and Pss are mentioned in the Talm or Midrashim, and only one, Nu 9 10, in the Mish before the end of the 2d cent., by which time its meaning had been lost. The lower limit, therefore, for their origin is the end of the 1st cent. AD. They have been, like most things not previously annexed by Moses, assigned to Ezra; but the LXX shows no sign of them. They, therefore, probably were inserted at the end of the 1st cent. BC, or in the 1st cent. AD. As four only occur in the Prophets and one in the Hagiographa, most care was evidently expended on the collation of the Law. Blau thinks the reference originally extended to the whole verse or even farther, and became restricted to one or more letters.

### 8. Dotted Words

In Nu 10, vs 35 and 36 are enclosed within two inverted *nūns* as if with brackets. In Ps 107 inverted *nūns* should stand before vs 23-28 and 40, with a note in the foot margin. These *nūns* were originally dots (*Siphre* on Nu) and stand for *nākhūh*, indicating that the verses so marked are in their wrong place (LXX Nu 10 34-36).

Large letters were used as our capitals at the beginnings of books, etc. Thus there should be a capital *nūn* at the beginning of the second part of Isa. But they serve other purposes also. The large *wāw* in Lev 11 42 is the middle letter of the Torah; so in the Israelites' *Credo* (Dt 6 4). Other places are Dt 32 4, 6; Ex 34 7, 14; Lev 11 30; 13 33; Isa 56 10, and often. Buxtorf's *Tiberias* gives 31 large and 32 small letters. Examples of the latter will be found in Gen 2 4; 23 2; Lev 1 1; Job 7 5, etc. The explanations given are fanciful.

### 9. Their Antiquity

10. Inverted *nūns*

11. Large and Small Letters

There are four letters suspended above the line in the MT. They will be found in Jgs 13 30; Job 38 13, 15; Ps 80 14 (13). The last probably indicates the middle letter of the Psalter. The first points to Manasseh being put for Moses. The two in Job are doubtful. In Nu 25 12 will be found a *wāw* cut in two, perhaps to indicate that the covenant was in abeyance for a time.

Abbreviations are found on early Jewish inscriptions and on coins. Thus the letter *shin* stands for *shānāh* = "year"; *yōdh sin* = "Israel"; *āleph* = 1; *bēth* = 2, etc. In the text used by the LXX the name Jeh seems to have been indicated merely by a *yōdh*, e.g. Ps 31 7 (6), "I hate" = LXX 30 7, "Thou latest" (cf 5 5), and the *yōdh* of the Heb = "O Jeh." In Jgs 19 18 the Heb "house of Jeh" = LXX "my house"; so Jer 6 11, 25 37. A curious example will be found Jer 3 19. The great corruption found in the numbers in the OT is probably due to letters or ciphers being employed. For wrong numbers cf 2 S 10 18; 24 13; 1 K 4 26 with || passages; also cf Ezer 2 with Neh 7, etc. Possible examples of letters representing numbers are: Ps 90 12, "so" = *kēn*, and *kāph* + *nūn* = 20 + 50 = 70; 1 S 13 1, *bēn shānāh* is perhaps for *bēn n shānāh*, "fifty years old"; in 14 14, an apparently redundant *k* is inserted after "twenty men"; *k* = 20.

Such was the Heb text in the 1st Christian cent. It was a Received Text obtained by collating MSS and rejecting variant readings. Henceforward there are no variant readings. But before that date there were, for the Gr and Sam often differ from the Heb. The Book of Jub (middle of 1st cent.) also varies. The fidelity of the scribes who drew up this text is proved by the many palpable errors which it contains.

**VI. Alteration of Original Documents.**—For various reasons the original documents were altered by the scribes, chiefly from motives

1. **Jehovah** of taste and religion. In the earliest and Baal literary period there was no objection to the use of the Divine name Jeh; later this was felt to be irreverent, and Elohim was put in its place; later still Jeh was written, but not pronounced. Hence in Pss 1–41, *Yahweh* occurs 272 t; *’Ēlōhīm* is hardly used as a proper name; in Pss 42–83 *’Ēlōhīm* occurs 200 t, *Yahweh*, only 44; cf esp. Ps 14 with 53; 40 14–18 with 70; 50 7 with Ex 20 2. Lastly in Pss 90–150 *Yahweh* is again used, and *’Ēlōhīm* as a proper name does not occur except in citations in 108 and 144 9. Cf also 2 K 22 19 with 2 Ch 34 27. A precisely parallel change is that of Baal into *bōsheth* ("shame"). At first there was no objection to compounding names with Baal meaning Jeh (Jgs 6 32; 8 35). Then objection was taken to it (Hos 2 16 or 18), and it was changed into Bosheth (Jer 3 24; Hos 9 10); hence Ishbosheth (2 S 2–4), Mephibosheth (2 S 4 4), Eliada (2 S 5 16), Jerrubesheth (11 21). Later still the objection lost force and the old form was restored, Eshbaal (1 Ch 8 33, 9 39), Merribaal (1 Ch 8 34), Beeliada (1 Ch 14 7; cf 3 8). The LXX follows the Heb: it treats Baal as feminine, i.e. = Bosheth. So too Molech takes its vowels from Bosheth; it should be Melech.

Words have been changed from motives of taste, e.g. "bless" is put for "curse" or "blaspheme" (1 K 21 10, LXX 20 10; Job 1 5; 2 5, 9, where the word "Lord" follows immediately; otherwise Ex 22 27, etc). Sometimes "the enemies of" was inserted (e.g. 2 S 12 14). Another use for the latter expression is 1 S 25 22, where it is not in the Gr. Cf further, 2 S 7 12, 14; 24 1, with the || passages in Ch.

In some 18 places the text was slightly altered by the correction (*tikkūn*) of the scribes, without any indication being inserted to show that it had been altered. The following are the passages: Gen 18 22, which originally ran "Jeh stood before Abraham"; Nu 11 15; 12 12; 1 S 3 13; 2 S 16 12;

20 1; Ezk 8 17; Hab 1 12; Mal 1 13; Zec 2 8 (12); Jer 2 11; Job 7 20; Hos 4 7; Job 32 3; Lam 3 20; Ps 106 20. The remaining two,

### 3. *Tikkūn sopherim*

to make 18, may be accounted for either by the third containing more than one correction, or by counting the parallels to the sixth. The LXX ignores the supposed original forms of the text, except in the case of 1 S 3 13 and Job 7 20. The Syr has the supposed original form of Nu 12 12 and *Siphre* of Nu 11 15, that is, it survived till the 2d cent. AD. But the rest must have been corrected very early. Like the *tikkūn* is the *’ittir sopherim*, that is, the subtraction or deletion of the conjunction "and" in five places, viz. Gen 18 5; 24 55; Nu 31 2 and Ps 68 25 (26) before the word "after"; and in Ps 36 6 (7) before "thy judgments."

**VII. Scribal Errors in the Text.**—The Heb text of the OT in no way resembles a text of one of the classics which is obtained by collating many MSS and eliminating all errors as far as possible. It is to all intents and purposes a MS, and displays all the forms of error found in all MSS. These are the following, classifying them according to their source.

Failure to understand the sense gives rise to wrong division into words, e.g. Am 6 12, "with oxen" (pl.) should probably be "with oxen [collective] the sea"; Jer 15 10; 22 14; Ps 73 4 (cf above V 1). Marginal notes may have found their way into the text, e.g. Ps 40 8, 9, "In a volume of a book it is written *alāy*," referring to *k* in ver 7; 2 S 1 18 (see Wellhausen).

Due to the eye are repetitions, transpositions, omissions, mistaking one letter for another, and so forth. Repetitions will be found: 2 S 6 3, 4

2. **Errors of the Eye** (LXX): 1 K 15 6 (=14 30); Ex 30 6 (LXX); Lev 20 10; 1 Ch 9 35–44 = 8 29–38; Isa 41 1 (cf 40 31); 53 7; Ps 35 15; 37 40, and very often. Omissions may be supplied from || passages or VSS, as 1 Ch 8 29–31 from 1 Ch 9 35–37; cf 9 41; Josh 22 34 (from Syr); Jgs 16 2; Gen 4 8 (Sam Pesh); Prov 10 10 (LXX Syr); 11 16 (LXX Syr); 2 S 17 3 (LXX).

Transpositions of letters will be found (Josh 6 13; Isa 8 12; cf vs 13, 14). Sometimes a letter slips from one word into another, as in 1 S 14 50, 51; Jer 18 23; Ps 139 20. Other examples are Jgs 10 12, and many times. Words are transposed in Ps 35 7; 95 7; 1 K 6 17, etc. Examples of transposition of verses will be found: Gen 24 29b follows ver 30a; Isa 38 21, 22 follows ver 8; cf 2 K 20 6–8; Isa 40 19, 20 should go with 41 6 ff. Most omissions and repetitions are due to homoeoteleuton or homoearchy. Similar letters are frequently mistaken for one another. Examples are: *d* and *r* (Ps 110 3; 2 S 22 11; cf Ps 18 11). Traditions mention 6 other places, as well as 154 in which *wāw* and *yōdh* are interchanged; other examples are: Josh 9 4; Dt 14 13; cf Lev 11 14; 2 Ch 22 10; cf 2 K 11 1.

Errors due to the ear would arise when one scribe was dictating to another. Such are: *lō* = "not," for *lō* = "to him," in 15 places (Ps 100 3, etc). Also Jeh and Adonal would be sounded alike. Again we have Adoram in 1 K 12 18 and Hadoram in 2 Ch 10 18.

Failure of memory in copying would explain the occurrence of synonymous words in || passages without any apparent motive, as for "I call" in 2 S 22 7 and Ps 13 7, and the interchange of Jeh and Adonal. In Jer 27 1 Jehoiakim should be Zedekiah.

Many of the scribal errors in the MT are due to carelessness and ignorance: in Gen 36 2, the last "daughter" should be "son"; Nu 26 8, "sons" for son, a common error; cf 1 Ch 3 22; 1 Ch 6 13 (28), *Vashnī* means "and the second" (*w<sup>h</sup>hāshēnī*); cf 1 S 8 2; also in 1 S 13 1 (cf above V, 13), where a number has dropped out, as also perhaps Isa 21 16, and 2 S 3 7, where Ishbosheth has fallen like Mephibosheth. In 2 S 23 18, 19 the first "three" should be "thirty." Cf also Gen 3 10 (Syr); 2 Ch 22 6; Ezk 43 13, and often. The Books of S seem to be the most carelessly copied of all the OT books, though the text of Ezk is in some respects more unintelligible. In Jer the LXX is shorter by one-eighth than the Heb, but it is doubtful which is original.

**VIII. History of the Text.**—The consonantal text of the OT was what it now is by the 1st or at latest the 2d Christian century. During the next four centuries it was minutely studied, the number of its words and even of its letters being counted. The results of this study are found chiefly in the Talm.

All such study was oral. During this period the text remained a purely consonantal text plus the *puncta extraordinaria*.

The text was not always read, however, exactly as it was written. Soon after the return from Babylon changes were made. Perhaps the

**1. Changes Made in Reading**

earliest was that the proper name Jehon was read Adonai, whence the LXX, and through it the NT "Lord." The reason will be found in Lev 24 11, where render "pronounced the name." Sometimes the change was due to motives of taste (Dt 28 30; 1 S 6 11; 2 K 18 27); but the commonest ground was grammar or logic. Thus a word was frequently read which was not in the text at all (Jgs 20 13; 2 S 18 20); or a word was omitted in reading (2 S 15 21; 2 K 5 18); or the letters of a word were transposed, as in Josh 6 13; or one letter was put for another, esp. *wāw* for *yōdh* or *yōdh* for *wāw*; or words were divided in reading otherwise than in the text (see above V, 1). The written text is called the K<sup>t</sup>hibh ("written"); what was read is called the K<sup>r</sup>ē ("read").

The scribes during these centuries, besides fixing the reading, took means to preserve the text

**2. Preservation of Text**

by counting the words and letters, and finding the middle verse (Jgs 10 8; Isa 33 21), and so forth. The middle verse of the Law is Lev 8 7, and the middle of the words falls in 10 16. The middle verse of the Heb Bible is Jer 6 7. Note was made of words written abnormally (Hos 10 14; Mic 1 15; Isa 3 8) and lists were made up. All such lists were retained in the mind; nothing was written.

When the public reading of the Law was accompanied by an Aram. tr (Neh 8 8), the division of the text into verses would arise spontaneously.

**3. Division into Verses**

The Mish gives rules for the number of verses to be read at a time before translating. These verses were separated by a space only, as the words were. Hence VSS frequently divide differently for the Heb, as Hos 4 11; Isa 1 12. In the Heb itself there are 28 old verse divisions no longer observed (see Baer on Hos 1 2). The space is called *pišqā'* and the verse *pāšūl*.

About the same time the Law was divided into sections (*pārāshāh*) for the annual reading. In Pal

**4. Sections of the Law**

the Law was read through once in 3½ years; in Babylon once a year. Hence the Law is divided into 54 sections (Gen 6 9; 12 1, etc) for the annual reading. It is also divided into 379 "shut" sections, indicated by a space in the middle of a line, and 290 "open" sections, indicated by a space at the end of a line. In printed texts these sections are noted by the letters *š* and *p*, but, if they coincide with one of the 54, by *ššš* or *ppp*. The Palestinian division was into 154 *šdhārīm*.

From Maccabean times 54 passages (*haphtārōth*) were selected from the Prophets for the purposes of the synagogue (Lk 4 17). The Prophets were also divided into smaller sections.

**5. Sections of the Prophets**

As in the case of the Law (Ex 6 28), there are cases of false division (Isa 56 9; Hag 1 15).

In the Heb Bible certain passages were early written in a peculiar way to resemble the bricks in the wall of a house, either in three

**6. Poetical Passages**

columns, a half-brick upon a brick and a brick upon a half-brick (Ex 15; Jgs 5; 2 S 22), or in two columns, a half-brick upon a half-brick and a brick upon a brick (Dt 32; Josh 12; Est 9). In the LXX, Pss, Prov, Eccl, Cant, Job are written in *stichs*; but that this was not done in Heb seems proved by

the variations as to the number of lines (Ps 65 8; 90 2.11).

The number of books is 24, S, K, Ch each counting as one, Ezr including Neh, the twelve Minor Prophets counting one book (Mic 3 12 is the

**7. Division into Books**

The Law counts 5 books, Pss one, though the division of it into 5 books is ancient (cf Ps 106 48 with 1 Ch 16 35.36). By joining Ruth to Jgs and Lam to Jer, the number 22 was obtained—the number of letters in the Heb alphabet. When, probably about the 3d cent. AD, leather rolls gave place to parchment books, it would be possible to have the whole Bible in one volume and the question of the order of the books would arise. The order in the Talm is as follows: The Law (5), the Prophets (8), Josh, Jgs, S, K, Jer, Ezk, Isa, and the XII, the Hagiographa or K<sup>t</sup>thūbhīm (11), Ruth, Pss, Job, Prov, Eccl, Cant, Lam, Dnl, Est, Ezr, Ch. The Prophets are usually subdivided into Former: Josh, Jgs, S, K; and Latter: Jer, Ezk, Isa and the XII. The traditional or "Masoretic" order places Isa before Jer, and in the Hagiographa the order is: Ch, Pss, Job, Prov, Ruth, Cant, Eccl, Lam, Est, Dnl, Ezr, the middle verse being Ps 130 3. The order found in printed texts is that of German MSS. The books receive their names from a word near the beginning, from their contents, or from their supposed author.

**IX. The Vocalization of the Text.**—About the time of the Reformation it was the universal belief that the vowel-marks and other points were of equal antiquity with the consonants. The Jews believed Moses received them orally and Ezra reduced them to writing.

The first to assign a late date to the points was Elias Levita (1468–1549). The battle was fought out in the 17th cent. Ludovicus Cap-

**1. Antiquity of the Points**

pellus (d. 1658) argued for a date about 600 AD. The Buxtorfs defended the old view. The following are the facts.

When the LXX was made, the Heb text had not even as many vowel-letters as it has now, and still

**2. Probable Date of Invention**

less points; nor when the Syr version was made in the 2d cent., or Jerome's Vulg between 393–405, or the earlier Tgs. Lastly, the points were unknown to the Talm. They, therefore, did not exist before 600 AD. The earliest authority on the points is Aaron ben Asher of the school of Tiberias (d. about 989). He wrote a copy of the Heb Bible with all the points, which became the standard codex. The probable date is, therefore, taken to be about the year 700; and this agrees with what was taking place in regard to Gr, Syr and Arab. MSS. The Jews probably borrowed from the Syrians.

No doubt, at first, many systems of pointing existed. Of these, two survived, the Palestinian and Bab, or superlinear. The chief

**3. Various Systems and Recensions**

features of the latter are that the signs are placed above the line; it has no sign for *e* (*seghōl*), and has but one system of accents. The Palestinian, the one familiar to us, exists in two recensions, those of Ben Asher and of his contemporary, Ben Naphtali of Babylon; hence a Western and an Eastern.

**X. The Palestinian System.**—Since the vocalization of the text took place about 700 AD, it will be understood that it differs considerably from the living language. What that was may be found from the transliteration of proper names in the LXX, in Origen and Jerome, and from a comparison with modern Arabic.

A comparison with Arab. indicates that the Heb *hēth*, and it is certain from the LXX that the 'ayin,

had each two distinct sounds. This difference is not shown in the pointing, though a point was used to distinguish the two sounds of *b*, *g*, *1*. The Consonants *d*, *k*, *p*, *t*, and of *s*, and *sh* and the two values of *h*. The absence of this point is indicated by *rāp̄heh*. The same point marks the doubling of a consonant. The gutturals and *r* are not doubled, though they certainly were when the language was spoken (cf Gen 43 26; Ezk 16 4, etc).

The system of vowel-marks attempts to reproduce the sounds exactly. Thus the short *a*-sound which must precede a guttural letter is indicated, and before a guttural *i* and *u* are replaced by *e* and *o*. On the other hand *y* before *i* does not seem to have been sounded in some cases. Thus the LXX has *Israēl*, but *Ieremias*. *Sh'wā'* is said by Ben Asher to sound *i* before *y*; before a guttural it took the sound of the guttural's vowel, as *mō'ōdh* (*mō'ōdh*), and had other values as well.

There is a special accentual system for the poetical books, Prov, Pss, and Job (except the prose parts). The titles and such marks as *šēlāh* are in the Pss accented as forming part of the verse. The accents had three values, musical, inter-punctual, and strictly accentual. But these values have to do with the language, not as it was spoken, but as it was chanted in the public reading of the synagogue.

The words were not always pointed in the usual way, but sometimes according to subjective considerations. Thus the phrase "to see the face of God" is pointed "to appear before God," on account of Ex 33 20 (Ps 42 3; Isa 1 12). Similarly in Eccl 3 21, "which goeth upward" is put for "whether it goeth upward." See also Jer 34 18; Isa 7 11. Frequently the punctuation is inconsistent with itself. Thus, "gathered to his peoples" (Gen 35 29), but "gathered to my people" (sing., Gen 49 29). So *pe'lishtim*, "Philistines," receives the article with prepositions, otherwise not. In many places two pointings are mixed, as if to give a choice of readings (Ps 62 4; 68 3, and often).

**XI. The Masorah.**—The Heb text as printed with all the points and accents is called the Masoretic text. Masorah, or better, *Maṣṣō-*

**1. Meaning of the Term** *reth*, is derived from a root meaning "to hand down" (Nu 31 5). This tradition began early. Rabbi Akiba (d. 135) called it a "hedge about the Law." It tells the number of times a particular expression occurs, and mentions synonymous expressions, and so forth. The remarks placed in the side margin of the codex, often merely a letter denoting the number of times the word occurs, are called the *M. parva*. The notes were afterward expanded and placed in the top and bottom margins and called the *M. magna*. Notes too long for insertion in the margin were placed sometimes at the beginning, generally at the end of the codex, and called the *M. finalis*. The Masorah differs with different MSS; and there is an Eastern and a Western Masorah.

The oldest and most important part of the Masorah lies in the readings which differ from the written text, called *K'ṛē*. These may represent

**2. The K'ṛē** variant readings of MSS, esp. a class and *Kethibh* of them called *š'bhīr*. The most are mere errata and corrigenda of the text. Such are the four *K. perpetua*, 'ād'hōnāy (for Y H W H), Jerusalem, Issachar and *hā'*, in the case of which the read form is not appended at the foot of the page. Sometimes the emendation is right, as in Am 8 8; cf 9 5; sometimes the *K'ṛē* represents an archaic form (Jgs 9 8.12; Isa 32 11).

A *K'ṛē* was inserted at 1 S 17 34 to correct a misprint in the Venice Bible of 1521.

Other notes at the foot of the page draw attention to redundant or defective writing. Directions for the arrangement of the text are given

**3. Other Features** Each book concludes with a note giving the number of verses, sections, middle verse and other particulars about the book. The second last verses of Isa, Mal, Lam, Eccl are repeated after the last, which is ill-omened.

**XII. MSS and Printed Texts.**—The MSS of the Heb Bible are not nearly so old as those of the Gr, old Heb MSS being generally destroyed. By far the oldest MS of any part of the Bible is the Papyrus Nash of about 150 AD, containing the Decalogue and *Sh'mō'* (Dt 6 4).

Next comes the St. Petersburg codex of the latter Prophets of 916 AD, though Ginsburg considers a MS of the Pent (Brit. Mus. Orient. 4445) older. The pointing of the latter is Palestinian; of the former, super-linear. The oldest MS of the whole OT is dated 1010 AD.

The following are the chief printed texts: The Psalter of 1477, place unknown, with comm. of Kimhi. The first few pss are vowelized; the Pent, 1482, Bologna, with Rashi and Tr Onkelos; perhaps the Five Rolls appeared at the same time; the Prophets, unpointed, 1485-86, at Soncino with Rashi and Kimhi; the Hagiographa, 1486-87, at Naples, with points, but not accents, and comms. (In the last two Y H W H and 'Elohim are spelled Y H D H and 'Elo-dhim); the 2d ed of the Pent at Faro in Portugal, 1487, first without comm.; the *editio princeps* of the whole OT with points and accents, but no comm., finished at Soncino, February 14, 1488, reprinted in 1491-93, and in the Brescia Bible of 1494. The last was the one used by Luther. Owing to persecution, the next edition was not till 1511-17.

The first Christian edition of the Heb text is that contained in the *Complutensian Polyglot*, finished July 10, 1517. It has many peculiarities, and first discarded the Masoretic sections for the Christian chapters, the Vulg being followed.

**3. Later Editions** The first rabbinic Bible—that is, pointed and accented text, with Masorah, Tgs, and comms.—was printed by Daniel Bomberg at Venice in 1516-17. The division of S, K, Ch, and Eṛ into two books each is first marked here in a purely Heb text, and the consonants of the *K'ṛē* first given in the margin. Previously the vowels were inserted in the text only. Thus in Isa 44 14, Luther did not observe the small *nūn*, taking it for a *zayin*. What is called, however, the *editio princeps* of the rabbinic Bible is Bomberg's second edition, ed by Jacob ben Hayyim (1524-25). This forms the standard edition of the MT. S and K are each treated as two books. *Š'bhīrim* are noticed for the first time, and the *K'ṛē*s marked with *k*. The *Polyglot* of Arias Montanus (1567-71) used the dilatate letters 'h, l, t, m, broadened to fill up lines, and first numbered the chapters (in Heb letters). Buxtorf's rabbinic Bible appeared in 1618-19; the Paris *Polyglot* in 1629-44; the London *Polyglot* of Walton in 1654-57, which first gives the Ethiopic and Pers VSS; that of Athias in 1661, which first inserted the numbers of Christian chapters in the clauses at the end of the books of the Law, the Mantua edition of 1744 inserting them for all the books. In the last is embodied the Masoretic comm. of Solomon de Norzi (1626). Recent editors are Baer and Ginsburg. Special mention must be made of the edition of Kittel which inserts the variant readings of the VSS at the foot of the page.

In modern editions of the Heb text the numbers of the Christian chapters are inserted. The chapters had their origin in the Vulg, and are

**4. Chapters and Verses** variously ascribed to Lanfranc (d. 1089), Stephen Langton (d. 1228), but with most probability to Hugo de Sancto Caro (13th cent.). They mostly coincide with the Masoretic sections, and came in with the Polyglots from 1517 on, being used first in a purely Heb text in 1573-74. Some modern editions mark the verses in the margin, the 5's in Heb letters, except 15, which is denoted by *!w=9+6*, instead of *yh=10+5*, because the latter would = Yah. After the *Clausula Masoretica* at the end of Ch and elsewhere, there is an extended note taken from 1 Ch 19 13 (2 S 10 12).

**LITERATURE.**—Benzinger, *Hebräische Archäologie*, Leipzig, 1894; Berger, *Histoire de l'écriture dans l'antiquité*, Paris, 1892; Blau, *Masoretische Untersuchungen*, Strassburg, 1891; *Einleitung in die heilige Schrift*, Budapest,

1894; *Studien zum althebräischen Buchwesen*, Pt. I, Strassburg, 1902; Buhl, *Canon and Text* (E<sup>t</sup> by J. Macpherson), Edinburgh, 1892; Butin, *The Ten Negadoth of the Torah*, Baltimore, 1906; Buxtorf (father), *Tiberias sive Commentarius Masoreticus*, Basel, 1620; Buxtorf (son), *Tractatus de Punctorum Origine*, etc, Basel, 1648; Cappellus, *Ara-num Punctationis Revelatum*, Leyden, 1624; Chwolson, *Corpus Inscriptionum Hebraicarum*, St. Petersburg, 1882; Driver, *Notes on the Hebrew Text of Samuel*, Oxford, 1913; Edersheim, *History of the Jewish Nation*, London, 1896; Etheridge, *Jerusalem and Tiberias* ("Post-Biblical Hebrew Literature"), London, 1856; Frankel, *Ueber palästinsische und alexandrinische Schriftforschung*, Breslau, 1854; Geden, *The Massoretic Notes Contained in the Edition of the Heb Scriptures, Published by the British and Foreign Bible Society*, London, 1905; Geiger, *Urschrift und Uebersetzungen der Bibel*, Breslau, 1857; Ginsburg, *Intro to the . . . Heb Bible*, London, 1897; *The Masorah*, London, 1880-85; Kennedy, *The Note-Line in the Heb Scriptures*, Edinburgh, 1903; Kenyon, *Our Bible and the Ancient MSS*, London, 1898; King, *The Pss in Three Collections* (on the triennial cycle), Cambridge, 1898; König, *Einführung in das AT*, Bonn, 1893; Loisy, *Histoire critique du texte et des versions de la Bible*, Paris, 1892-95; Nowack, *Lehrbuch der hebräischen Archäologie*, Freiburg and Leipzig, 1894; De Rougé, *Mémoire sur l'origine égyptienne de l'alphabet phénicien*, Paris, 1874; Schürer, *Geschichte des jüdischen Volkes im Zeitalter Jesu Christi* (E<sup>t</sup> by John Macpherson and others), Edinburgh, 1890; Schwab, *Jerus Talm* (Fr. tr.), Paris, 1871-90; Strack, *Prolegomena Critica in Velus Testamentum Hebraicum*, Leipzig, 1873; *Einführung in den Talmud*, Leipzig, 1894; Taylor, *The Alphabet*, London, 1883; T. H. Weir, *A Short History of the Heb Text of the OT*, London, 1907; Winckler, *Die Thontafeln von Tell-el-Amarna*, Berlin, 1896; *The Tell-el-Amarna Letters*, Berlin, London and New York, 1896; Wolf, *Bibliotheca Hebraea*, Hamburg and Leipzig, 1715-33; Wünsche, *Bibliotheca Rabbinica*, Leipzig, 1880.

Encyclopaedias: Cheyne and Black, *EB*, London, 1899-1903; Fairbairn, *Imperial Bible Dict.*, London, 1866 ("OT"; "Scriptures"; "Writing," by D. H. Weir); *HDB*, Edinburgh, 1898-1904 ("Text of the Old Testament," by H. L. Strack); Herzog, *RE*, Leipzig, 1896 ff.; *Jew Enc.*, New York and London, 1901-6; Vigoureux, *Dictionnaire de la Bible*, Paris, 1891 ff.

Hebrew texts: *Dikduke ha Te'amim des Ahron . . . ben Asher*, ed by Baer and Strack, Leipzig, 1879; *Massoreth ha-Massoreth of Elias Levita*, with E<sup>t</sup> and notes by C. D. Ginsburg, London, 1867; *Midrash hag-Gadol: Genesis*, ed by S. Schechter, Cambridge, 1902; *Das Buch, Ochia Waosha*, ed by Frensdorff, Hanover, 1864; *Mishnah*, with Lat<sup>r</sup>, by Guil. Surenhusius, Amsterdam, 1698-1703; *Sifra*, ed by Jacob Schlossberg, Vienna, 1862; *Sifre*, ed by M. Friedmann (first part), Vienna, 1864; *Saferim*, ed by Joel Müller, Vienna, 1878; *Babylonian Talm*, ed with Ger. tr) by Lazarus Goldschmidt, Berlin, 1896-.

Periodicals: *Academy*, XXXI, 454, "The Moabite Stone"; *Good Words*, 1870, 673; "The Moabite Stone," by D. H. Weir; *Jewish Quarterly Review*, Dr. A. Büchler on "The Triennial Cycle," V, 420, VI, 1; "E. G. King on the Influence of the Triennial Cycle upon the Psalter," by I. Abrahams, April, 1904; "Neue Masoretische Studien," by Blau, January, 1904; "On the Decalogue Papyrus," by F. C. Burkitt, April, 1903; *Journal of Theological Studies*, V, 203, "The Influence of the Triennial Cycle upon the Psalter," by E. G. King; *PEF*: "Heb Mosaic Inscription at Kefr Kenna," by Clermont-Ganneau, October, 1901; "On the Siloam Inscription," 1881, 198; "On the Excavations at Taanach and Megiddo," 1904, 180, 1905, 78; *Proceedings of the Society of Biblical Archaeology*: E. J. Pilcher, "On the Date of the Siloam Inscription," XIX, 165, XX, 213; "On the Decalogue Papyrus," by S. A. Cook, January, 1903; "Heb Illuminated MSS of the Bible of the 11th and 12th Cents.," by M. Gaster, XXII, 226; *Scottish Review*, IX, 215, "The Apocryphal Character of the Moabite Stone," by Albert Löwy; *Studia Biblica et Ecclesiastica*, III, 1, "The Introduction of the Square Characters in Biblical MSS, and an Account of the Earliest MSS of the OT, with a Table of Alphabets and Facsimiles," by Ad. Neubauer; *Mittheilungen und Nachrichten des deutschen Palaestina-Vereins*: "On the Excavations at Taanach," by Sellin, 1902, 13, 17, 33, 1903, 1, and 1905, no. 3; "On the Excavations at Tell el Mutesellim," by Schumacher, 1904, 14, 33, and 1906, no. 3; and by Benzinger, 1904, 65; *Zeitschrift des deutschen Palaestina-Vereins*: "On the Siloam Inscription," by Socin, XXII, 61; *Zeitschrift der deutschen morgenländischen Gesellschaft*: "Zur Geschichte der hebräischen Accente," by P. Kahle, 1901, 167.

## THOMAS HUNTER WEIR

**THADDAEUS**, tha-dé'us (Θαδδαιος, *Thad-daios*): One of the Twelve Apostles (Mt 10 3; Mk 3 18). In Mt 10 3 AV, the reading is "Lebbeaus, whose surname was Thaddaeus." The name corresponds to Judas, the son (RV), or brother (AV), of James, given in the lists of Lk 6 16; Acts 1 13. See **JUDAS NOT ISCARIOT**; **LEBBAEUS**.

The "Gospel of the Ebionites," or "Gospel of the Twelve Apostles," of the 2d cent. and mentioned by Origen, narrates that Thaddaeus was also among those who received their call to follow Jesus at the Sea of Tiberias (cf Mt 4 18-22; see also **SIMON THE CANANAEAN**).

According to the "Genealogies of the Twelve Apostles" (cf Budge, *Contendings of the Apostles*, II, 50), Thaddaeus was of the house of Joseph; according to the "Book of the Bee" he was of the tribe of Judah. There is abundant testimony in apocryphal lit. of the missionary activity of a certain Thaddaeus in Syria, but doubt exists as to whether this was the apostle. Thus (1) according to the "Acts of St. Peter" (cf Budge, II, 466 ff) Peter appointed Thaddaeus over the island of Syria and Edessa. (2) The "Preaching of the blessed Judas, the brother of Our Lord, who was surnamed Thaddaeus" (Budge, 357 ff), describes his mission in Syria and in Dacia, and indicates him as one of the Twelve. (3) The "Acta Thaddaei" (cf Tischendorf, *Acta Apostolorum Apocrypha*, 1851, 261 ff) refers to this Thaddaeus in the text as one of the Twelve, but in the heading as one of the Seventy. (4) The Abgar legend, dealing with a supposed correspondence between Abgar, king of Syria, and Christ, states in its Syr form, as tr<sup>d</sup> by Eusebius (*HE*, I, xiii, 6-22) (cf THOMAS), that "after the ascension of Christ, Judas, who was also called Thomas, sent to Abgar the apostle Thaddaeus, one of the Seventy" (cf Hennecke, *Neuestamentliche Apokryphen*, 76 ff). Jerome, however, identifies this same Thaddaeus with Lebbaeus and "Judas . . . of James" of Luke (Lk 6 16). Hennecke (op. cit., 473, 474) surmises that in the original form of the Abgar legend Thomas was the central figure, but that through the influence of the later "Acts of Thomas," which required room to be made for Thomas' activity in India, a later Syr recension was made, in which Thomas became merely the sender of Thaddaeus to Edessa, and that this was the form which Eusebius made use of in his tr. According to Phillips (cf Phillips, *The Doctrine of Addai the Apostle*), who quotes Zahn in support, the confusion may be due to the substitution of the Gr name Thaddaeus for the name Addai of the Syr MSS. See **APOCRYPHAL ACTS**.

The general consensus seems to indicate, however, that both Thomas and Thaddaeus the apostle had some connection with Edessa. Of the various identifications of Thaddaeus with other Bib. personages which might be inferred from the foregoing, that with "Judas . . . of James" is the only one that has received wide acceptance.

The burial place of Thaddaeus is variously placed at Beirút and in Egypt. A "Gospel of Thaddaeus" is mentioned in the Decree of Gelasius.

C. M. KERR

**THAHASH**, thá'hash. See **TAHASH**.**THAMAH**, thá'ma. See **TEMAH**.

**THAMAR**, thá'mär (Θάμαρ, *Thámar*): AV; Gr form of "Tamar" (thus Mt 1 3 RV). Mother of Perez and Zerah.

**THAMMUZ**, tham'uz (תַּמְזֻז, *tammüz*). See **TAMMUZ**.

**THAMNATHA**, tham'na-tha. See **TIMNATH**.

**THANK**, thank, **THANKS**, thanks, **THANKS-GIVING**, thanks-giv'ing, thanks-giv-ing: Both the vb. and the nouns appear almost uniformly for תַּנְתָּן, *yādhāh*, and εὐχαριστέω, *eucharistēō*, and their cognates. *Eucharistēō* is the usual Gr vb. for "to thank," but *yādhāh* takes on this force only



through its context and is rather a synonym for "praise" or "bless" (q.v.). LXX renders *yādhāh* usually by *ἐξομολογέω*, *exomologēō*, "speak forth together," "praise" (cf Tob 12 20; Sir 39 6, etc. and the use of "thank" in EV to correspond), and this vb. reappears in Mt 11 25 || Lk 10 21, with Eng. "thank" (RVm "praise"). Cf the use of *anthologēomai* (Lk 2 38) and *homologēō* (He 13 15, AV "giving thanks," RV "make confession"; AV is preferable). For *charis* in the sense of "thanks" (note the singular "thank" in AV Sir 20 16; Lk 6 32-34), see GRACE. 1 Pet 2 19 AV has "thank-worthy" for *charis*, RV "acceptable," RVm "grace."

BURTON SCOTT EASTON

**THANK OFFERING.** See SACRIFICE IN THE OT.

**THARA**, thā'ra, thār'a (Θαρά, *Thará*): AV; Gr form of "Terah" (thus Lk 3 34 RV).

**THARRA**, thar'a (Θαρρά, *Tharrá*): One of the two eunuchs, "keepers of the court," who with his companion Gabatha (Bigthan) formed a conspiracy against King Artaxerxes which was detected by Mordecai (Ad Est 12 1="Teresh" of Est 2 21; 6 2). Tharra and his companion were hanged. Jos (*BJ*, II, vi, 4) calls him "Theodestes."

**THARSHISH**, thār'shish (תַּרְשִׁישִׁי, *tarshish*). See TARSHISH.

**THASSI**, thas'i (N V, Θασσι, *Thassai*, B, Θασσις, *Thassís*): The surname of Simon, the brother of Judas Maccabaeus (1 Macc 2 3; Syr "Tharsi"). It is uncertain what the name means, perhaps "director" or "guide," since Simon was "a man of counsel," or "the zealous."

**THAT DAY.** See DAY OF THE LORD.

**THEATRE**, thē'a-tēr (Acts 19 29.31). See GAMES.

**THEBES**, thēbz. See NO-AMON.

**THEBEZ**, thē'bez (תְּבֵזַי, *tēbhēz*, "brightness"; B, Θηβῆς, *Thēbēs*, A, Θαίβαις, *Thaibais*): A city in Mt. Ephraim which refused submission to Abimelech when he set up as king of Israel. After the reduction of Shechem he turned his arms against Thebez. There was a strong tower within the city—the citadel—into which all the inhabitants gathered for safety, climbing onto the roof of the tower. Abimelech incautiously venturing near the tower, a woman cast an upper millstone upon his head and broke his skull. Fearing the shame of perishing by the hand of a woman, he persuaded his armor-bearer to thrust him through (*Jgs* 9 50 ff). The incident is alluded to in 2 S 11 21. *Onom* places it 13 Rom miles from Neapolis (*Nāblus*) on the road to Scythopolis (*Beisān*). There is no doubt that it is represented by *Tūbās*. This is a village situated in a district of considerable fertility, about 10 miles from *Nāblus*. There are many olive trees. The rain is captured and led to rock-cut cisterns, whence the village draws its water-supply. According to the Samaritans the tomb of *Neby Toba* marks the grave of the patriarch Asher.

W. EWING

**THECOE**, thē-kō'ē (1 Macc 9 33). See TEKOIA.

**THEE-WARD**, thē'wērd. "To thee-ward" (1 S 19 4)=toward thee. See WARD.

**THEFT.** See CRIMES; PUNISHMENTS.

**THELASAR**, thē-lā'sar (תְּלַסָּר, *tēla'ssār*, תְּלַסָּר, *tēlassār*). See TELASSAR.

**THELERSAS**, thē-lūr'sas (Θηλερσάς, *Thelersás* [1 Esd 5 36]). See TEL-HARSHA.

**THEOCANUS**, thē-ok'a-nus: 1 Esd 9 14 AV=RV "Thocanus."

**THEOCRACY**, thē-ok'ra-si (θεοκρατία, *theokratía*, from θεός, *theós*, "a god," and κράτος, *krátos*, "power"; after the analogy of the words "democracy," "aristocracy," and the like): "Theocracy" is not a Bib. word. The idea, however, is Bib., and in strictness of speech exclusively Bib. The realization of the idea is not only confined to Israel, but in the pre-exilic history of Israel the realization of the idea was confined to the Southern Kingdom, and in post-exilic history to the period between the return under Ezra and the days of Malachi.

For the word "theocracy" we are, by common consent, indebted to Jos. In his writings it seems to occur but once (*CAP*, II, xvi). The passage reads as follows: "Our lawgiver had an eye to none of these," that is, these different forms of government, such as monarchy, aristocracy, oligarchy, and others of which Jos had been speaking, "but, as one might say, using a strained expression, he set forth the national polity as a theocracy, referring the rule and might to God" (Stanton's tr). It is generally agreed that the language here used indicates that Jos knew himself to be coining a new word.

If, now, we turn from the word to the OT idea to which it gives fitting and apt expression, that idea cannot be better stated than it has been by Kautzsch—namely, "The notion of theocracy is that the constitution [of Israel] was so arranged that all the organs of government were without any independent power, and had simply to announce and execute the will of God as declared by priest and prophets, or reduced to writing as a code of laws" (*HDB*, extra vol, 630, 1, *init.*). The same writer is entirely correct when he says that in what is known in certain circles as "the PC"—though he might have said in the OT generally—"everything, even civil and criminal law, is looked at from the religious standpoint" (ib, ut supra).

If the foregoing be a correct account of the idea expressed by the word "theocracy," and particularly if the foregoing be a correct account of the OT representation of God's relation to, and rule in and over Israel, it follows as a matter of course that the realization of such an idea was only possible within the sphere of what is known as *special revelation*. Indeed, special revelation of the Divine will, through Divinely chosen organs, to Divinely appointed executive agents, is, itself, the very essence of the idea of a theocracy.

That the foregoing is the OT idea of God's relation to His people is admitted to be a natural and necessary implication from such passages as *Jgs* 8 23; 1 S 8; cf 12 12; 2 Ch 13 8; 2 S 7 1-17; Ps 89 27; Dt 17 14-20.

Upon any other view of the origin of the OT books than that which has heretofore prevailed, it is certainly a remarkable fact that whenever the books of the OT were written, and by whomsoever they may have been written, and whatever the kind or the number of the redactions to which they may have been subjected, the conception—the confessedly unique conception—of a government of God such as that described above by Kautzsch is evidenced by these writings in all their parts. This fact is all the more impressive in view of the further fact that we do not encounter this sharply defined idea of a rule of God among men in any other literature, ancient or modern. For while the term "theocracy" occurs in modern literature, it is evidently used in a much lower sense. It is further worth remarking that this OT idea of the true nature of God's rule in Israel has only to be

fully apprehended for it to become obvious that many of the alleged analogies between the OT prophet and the modern preacher, reformer and statesman are wholly lacking in any really solid foundation.

W. M. MCPHEETERS

**THEODOTION**, thē-ō-dō'shi-un. See LANGUAGE OF THE NT; SEPTUAGINT.

**THEODOTUS**, thē-od'ō-tus (Θεόδοτος, *Theódotos*):

(1) One of the three ambassadors sent by the Syrian general Nicanor to Judas to make peace (2 Macc 14 19).

(2) One who plotted to assassinate Ptolemy Philopator, but was prevented by a Jew, Dositheos (3 Macc 1 2 f).

**THEOLOGY**, thē-ol'o-ji. See BIBLICAL THEOLOGY; JOHANNINE THEOLOGY; PAULINE THEOLOGY.

**THEOPHILUS**, thē-of'i-lus (Θεόφιλος, *Theóphilos*, "loved of God"): The one to whom St. Luke addressed his Gospel and the Acts of the Apostles (cf Lk 1 3; Acts 1 1). It has been suggested that Theophilus is merely a generic term for all Christians, but the epithet "most excellent" implies it was applied by St. Luke to a definite person, probably a Rom official, whom he held in high respect. Theophilus may have been the presbyter who took part in sending the letter from the Corinthians to St. Paul, given in the "Acta Pauli" (cf Hennecke, *Neutestamentliche Apokryphen*, 378). There is also a magistrate Theophilus mentioned in the "Acts of St. James" as being converted by St. James on his way to India (cf Budge, *The Contendings of the Apostles*, II, 299), but these and other identifications, together with other attempts to trace out the further history of the original Theophilus, are without sufficient evidence for their establishment (cf also Knowing in *Expos Gr Test.*, II, 49-51). C. M. KERR

**THERAS**, thē'ras (Θέρα, *Théra*): The river by which the company assembled in preparation for the march to Jerus under Ezra (1 Esd 8 41.61). In Ezr 8 21.31 the name of the river is Ahava. Possibly the place is represented by the modern *Hit* on the Euphrates; but no certain identification is possible.

**THERMELETH**, thū'r'mē-leth (Θερμελεθ, *Thermēleth* [1 Esd 5 36]). See TEL-MELAH.

**THESSALONIANS**, thes-a-lō'ni-anz, **THE FIRST EPISTLE OF PAUL TO THE:**

- I. IMPORTANCE OF THE EPISTLE
  - II. CIRCUMSTANCES OF THE FOUNDING OF THE CHURCH
    1. Luke's Narrative in Acts
    2. Confirmation of Luke's Narrative in the Epistle
  - III. CONDITIONS IN THE THESSALONIAN CHURCH AS INDICATED IN THE LETTER
  - IV. ANALYSIS OF THE EPISTLE
    1. Paul's Past and Present Relations with the Thessalonians and His Love for Them
    2. Exhortations against Vice, and Comfort and Warning in View of the Coming of Christ
  - V. DOCTRINAL IMPLICATIONS OF THE EPISTLE
  - VI. THE EPISTLE'S REVELATIONS OF PAUL'S CHARACTERISTICS
- LITERATURE

**I. The Importance of the Epistle.**—The letter is esp. important as a witness to the content of the earliest Gospel, on account of its date and its well-nigh unchallenged authenticity. According to Harnack it was written in the year 48 AD; according to Zahn, in the year 53. It is likely that these two dates represent the extreme limits. We are thus justified in saying with confidence that we have

before us a document that could not have been written more than 24 years, and may very easily have been written but 19 years, after the ascension of Our Lord. This is a fact of great interest in view of the contention that the Jesus of the four Gospels is a product of the legend-making propensity of devout souls in the latter part of the 1st cent. When we remember that Paul was converted more than 14 years before the writing of the Epp., and that he tells us that his conversion was of such an overwhelming nature as to impel him in a straight course from which he never varied, and when we note that at the end of 14 years Peter and John, having fully heard the gospel which he preached, had no corrections to offer (Gal 1 11-2 10, esp. 2 6-10), we see that the view of Christ and His message given in this Ep. traces itself back into the very presence of the most intimate friends of Jesus. It is not meant by this that the words of Paul or the forms of his teaching are reproductions of things Jesus said in the days of His flesh, but rather that the conception which is embodied in the Ep. of the person of Christ and of His relation to the Father, and of His relation also to the church and to human destiny, is rooted in Christ's own self-revelation.

**II. Circumstances of the Founding of the Church.**—For the founding of the church we have

two sources of information, the Book of Acts and the Ep. itself. Luke's narrative is found in Acts 17. Here we are told that Paul, after leaving Philippi, began his next siege against entrenched paganism in the great market center of Thessalonica. He went first into the synagogues of the Jews, and for three Sabbath days reasoned with them out of the Scriptures. Some of them, Luke tells us, "were persuaded, and consorted with Paul and Silas; and of the devout Greeks a great multitude, and of the chief women not a few." This very naturally excited the jealousy of the Jews who found themselves losing the social prestige that came from having a large number of Greeks, including some of the nobility, resorting to them for instruction. Accordingly, they raised a mob of the worst men in town and brought the leading members of the church before the magistrate. These brethren, Jason and certain others, who seem to have been men of some property, were compelled to give bond to preserve the peace, and the intense feeling against Paul made it necessary for him, for the sake of these brethren as well as for his personal safety, to flee from the city.

The historicity of Luke's story of the founding of the church is strongly supported by the text of the Ep. Paul, for instance, notes that the work in Thessalonica began after they had been shamefully entreated at Philippi (1 Thess 2 2). He bears witness also in the same Epistle to the conflict in the midst of which the Thessalonian church was founded (see also 2 14). Paul's exhortation to salute *all* the brethren with a holy kiss, his solemn adjuration that this letter be read unto *all* the brethren (5 26.27), and his exhortation to despise not prophesying (5 20) are harmonious with Luke's account of the very diverse social elements out of which the church was formed: diversities that would very easily give rise to a disposition on the part of the more aristocratic to neglect the cordial greetings to the poorer members, and to despise their uncouth testimonies to the grace of God that had come to them (Acts 17 4).

Paul tells us that he was forced to labor for his daily bread at Thessalonica (1 Thess 2 9). Luke does not make mention of this, but he tells us of his work at tent-making in the next town where he

made a considerable stop (Acts 18 1-3), and thus each statement makes the other probable.

Perhaps, however, the most marked corroboration of the Acts which we have in the letter is the general harmony of its revelation of the character of Paul with that of the Acts. The reminiscences of Paul's work among them (1 Thess 2 1-12) correspond, for instance, in a marked way, in essence though not in style and vocabulary, with Luke's report of Paul's account of the method and spirit of his work at Ephesus (Acts 20 17-35). This, however, is only one of many correspondences which could be pointed out and which will at once be evident to anyone who will read the letter, and then go over Acts 13-28.

It may seem irrelevant thus to emphasize the historicity of Acts in an art. on Thessalonians, but the witness of the Ep. to the historicity of the Gospels and of Acts is for the present moment one of its most important functions.

**III. Conditions in the Thessalonian Church as Indicated in the Letter.**—A NT ep. bears a close resemblance to a doctor's prescription. It relates itself to the immediate situation of the person to whom it is directed. If we study it we can infer with a great deal of accuracy the tendencies, good or bad, in the church. What revelation of the conditions at Thessalonica is made in the First Ep.? Plainly, affairs on the whole are in a very good state, esp. when one takes into account the fact that most of the members had been out of heathenism but a few months. They were so notably devoted to God that they were known all over Macedonia as examples to the church (1 Thess 1 7). In particular the Christian grace of cordial good will toward all believers flourished among them: a grace which they doubtless had good opportunity to exercise in this great market town to which Christians from all parts would resort on business errands and where there would be constant demands on their hospitality (4 9-10).

There were, however, shadows in the picture. Some persons were whispering dark suspicions against Paul. Perhaps, as Zahn suggests, they were the unbelieving husbands of the rich ladies who had become members of the church. It was in answer to these criticisms that he felt called upon to say that he was not a fanatic nor a moral leper, nor a deceiver (2 3). When he is so careful to remind them that he was not found at any time wearing a cloak of covetousness, but rather went to the extreme of laboring night and day that he might not be chargeable to any of them (2 9), we may be sure that the Christians were hearing constant jibes about their money-making teacher who had already worked his scheme with the Philipians so successfully that they had twice sent him a contribution (Phil 4 16). Paul's peculiar sensitiveness on this point at Corinth (1 Cor 9 14,15) was possibly in part the result of his immediately preceding experiences at Thessalonica.

One wonders whether Greece was not peculiarly infested at this time with wandering philosophers and religious teachers who beat their way as best they could, living on the credulity of the unwary.

Paul's anxiety to assure them of his intense desire to see them and his telling of his repeated attempts to come to them (1 Thess 2 17-20) show rather plainly also that his absence had given rise to the suspicion that he was afraid to come back, or indeed quite indifferent about revisiting them. "We would fain have come unto you," he says, "I Paul once and again; and Satan hindered us."

Some also were saying that Paul was a flatterer (2 5), who was seeking by this means to carry out unworthy ends. This sneer indeed, after the reading of the letter, would come quite naturally to the superficial mind. Paul's amazing power to idealize his converts and see them in the light of their good intentions and of the general goal and

trend of their minds is quite beyond the appreciation of a shallow and sardonic soul.

More than this, we can see plain evidence that the church was in danger of the chronic heathen vice of unchastity (4 3-8). The humble members also, in particular, were in danger of being intoxicated by the new intellectual and spiritual life into which they had been inducted by the gospel, and were spending their time in religious meetings to the neglect of their daily labor (4 10-12). Moreover, some who had lost friends since their baptism were mourning lest at the second coming of Christ these who had fallen asleep would not share in the common glory (4 13-18). This is a quaint proof of the immaturity of their view of Christ, as though a physical accident could separate from His love and care. There was likewise, as suggested above, the ever-present danger of social cliques among the members (5 13,15,20,26,27). It is to this condition of things that Paul pours forth this amazingly vital and human Ep.

**IV. Analysis of the Epistle.**—The letter may be divided in several ways. Perhaps as simple a way as any is that which separates it into two main divisions.

*First, Paul's past and present relations with the Thessalonians, and his love for them (1 1-3 13):*

- (1) Greeting and Thanksgiving (1 1-10).
- (2) Paul reminds them of the character of his life and ministry among them (2 1-12).
- (3) The sufferings of the Thessalonians the same as those endured by their Jewish brethren (2 13-16).
- (4) Paul's efforts to see them (2 17-20).
- (5) Paul's surrender of his beloved helper in order to learn the state of the Thessalonian church, and his joy over the good news which Timothy brought (3 1-13).

*Second, exhortations against vice, and comfort and warning in view of the coming of Christ (4 1-5,28):*

- (1) Against gross vice (4 1-8).
- (2) Against idleness (4 9-12).
- (3) Concerning those who have fallen asleep (4 13-18).
- (4) Concerning the true way to watch for the Coming (5 1-11).
- (5) Sundry exhortations (5 12-28).

**V. Doctrinal Implications of the Epistle.**—The Ep. to the Thess is not a doctrinal letter. Paul's great teaching concerning salvation by faith alone, apart from the works of the Law, is not sharply defined or baldly stated, and the doctrine of the cross of Christ as central in Christianity is here implied rather than enforced. Almost the only doctrinal statement is that which assures them that those of their number who had fallen asleep would not in any wise be shut out from the rewards and glories at Christ's second coming (1 Thess 4 13-18). But while the main doctrinal positions of Paul are not elaborated or even stated in the letter, it may safely be said that the Ep. could scarcely have been written by one who denied those teachings. And the fact that we know that shortly before or shortly after Paul wrote the Ep. to the Gal. and the fact that he so definitely describes his attitude at this very time toward the preaching of the cross of Christ, in his reminiscences in 1 Cor (see esp. 1 Cor 2 1-5), show how foolish it is to assume that an author has not yet come to a position because he does not constantly obtrude it in all that he writes.

The Ep., however, bears abundant evidence to the fact that this contemporary of Jesus had seen in the life and character and resurrection of Jesus that which caused him to exalt Him to Divine honors, to mention Him in the same breath with God the Father, and to expect His second coming in glory as the event which would determine the destiny of all men and be the final goal of history. As such the letter, whose authenticity is now practically unquestioned, is a powerful proof that Jesus was a personality as extraordinary as the Jesus of the first three Gospels. And even the Christ of the Fourth Gospel is scarcely more exalted than He who now with God the Father constitutes the spiritual atmosphere in which Christians exist (1 Thess 1 1), and who at the last day will descend from heaven with a shout and with the voice of an archangel and the trump of God, and cause the dead in Christ to rise from their tombs to dwell forever with Himself (4 16,17).

**VI. The Epistle's Revelations of Paul's Characteristics.**—We notice in the letter the extreme tactfulness of Paul. He has some plain and humiliating warnings to give, but he precedes them in each case with affectionate recognition of the good qualities of the brethren. Before he warns against

gross vice he explains that he is simply urging them to continue in the good way they are in. Before he urges them to go to work he cordially recognizes the love that has made them linger so long and so frequently at the common meeting-places. And when in connection with his exhortations about the second coming he alludes to the vice of drunkenness, he first idealizes them as sons of the light and of the day to whom, of course, the drunken orgies of those who are "of the night" would be unthinkable. Thus by a kind of spiritual suggestion he starts them in the right way.

**LITERATURE.**—Bishop Alexander, the *Speaker's Comm.* (published in America under the title, *The Bible Comm.*, and bound with most excellent comms. on all of the Pauline Epp.), New York, Scribners; Milligan, *The Ep. to the Thess* (the Gr text with Intro and notes), London, Macmillan; Moffatt, *The Expositor's Gr Test.* (bound with comms. by various authors on the Pastoral Epp., Philem, He and Jas), New York, Dodd, Mead & Co.; Frame, *ICC*, New York, Scribners; Stevens, *An American Comm. on the NT*, Philadelphia, American Baptist Publication Society; Adeney, *The New Century Bible*, "1 and 2 Thess" and "Gal," New York, Henry Frowde; Findlay, "The Ep. to the Thess," *Cambridge Bible for Schools and Colleges*, New York, Putnam's; James Denney, "The Ep. to the Thess," *Expositor's Bible*, New York, Doran; the two latter are esp. recommended as inexpensive, popular and yet scholarly comms. *The Cambridge Bible* is a verse-by-verse comm., and Professor Denney on "Thess" in *Expositor's Bible* is one of the most vital and vigorous pieces of homiletical exposition known to the present writer.

### ROLLIN HOUGH WALKER THESSALONIANS, THE SECOND EPISTLE OF PAUL TO THE:

- I. IMPORTANCE OF STUDYING 1 THESS AND 2 THESS TOGETHER
- II. AUTHENTICITY
  1. Arguments against the Pauline Authorship
  2. Arguments for the Pauline Authorship
- III. THE MAN OF SIN
  1. Primary Reference
  2. Permanent Value of the Teaching concerning the Man of Sin
- IV. PAUL'S EXHORTATION TO QUIET INDUSTRY

**LITERATURE**

**I. Importance of Studying 1 Thess and 2 Thess Together.**—Those who hold to the Pauline authorship of the Ep. unite in ascribing it to a time but little subsequent to the writing of the First Letter. It is simply a second prescription for the same case, made after discovering that some certain stubborn symptoms had not yielded to the first treatment. 2 Thess should be studied in connection with 1 Thess because it is only from an understanding of the First Ep. and the situation that it revealed that one can fully grasp the significance of the Second. And more than that, the solution of the problem as to whether Paul wrote the Second Letter is likewise largely dependent on our knowledge of the First. It would, for instance, be much harder to believe that Paul had written 2 Thess if we did not know that before writing it he had used the tender and tactful methods of treatment which we find in the First Letter. It is as though one should enter a sick room where the physician is resorting to some rather strong measures with a patient. One is better prepared to judge the wisdom of the treatment if he knows the history of the case, and discovers that gentler methods have already been tried by the physician without success.

**II. Authenticity.**—The different treatment of the subject of the second coming of Christ, the different emotional tone, and the different relationships between Paul and the church presupposed in the First and Second Epp., have been among the Pauline causes which have led to repeated questionings of the Pauline authorship of 2 Thess. Scholars argue, in the first place, that the doctrine concerning the coming of Christ which we find in the Second Letter is not only differently phrased but is contradictory to that

in the First. We get the impression from the First Letter that the Day of the Lord is at hand. It will come as a thief in the night (1 Thess 5 2), and one of the main parts of Christian duty is to expect it (1 Thess 1 9.10). In the Second Letter, however, the writer urges strongly against any influence that will deceive them into believing that the Day of the Lord is at hand, because it will not be "except the falling away come first, and the man of sin be revealed, the son of perdition, he that opposeth and exalteth himself against all that is called God or that is worshipped" (2 Thess 2 1-4).

Again very plainly also, say the critics, a different relation exists between the writer and the church at Thessalonica. In the First Letter he coaxes; in the Second Letter he commands (1 Thess 4 1.2.9-12; 5 1-11; 2 Thess 2 1-4; 3 6.12-14). Moreover, the whole emotional tone of the Second Letter is different from that of the First. The First Ep. is a veritable geyser of joyous, grateful affection and tenderness. The Second Letter, while it also contains expressions of the warmest affection and appreciation, is quite plainly not written under the same pressure of tender emotion. Here, say the critics, is a lower plane of inspiration. Here are Paul's words and phrases and plain imitations of Paul's manner, but here most emphatically is not the flood tide of Paul's inspiration. Moreover, the lurid vision of the battle between the man of sin and the returning Messiah in the Second Letter is different in form and coloring from anything which we find elsewhere in Paul. These, and other considerations have led many to assume that the letter was written by a hand other than that of the Apostle to the Gentiles.

The hypothesis, however, that Paul was not the author of the Ep., while it obviates certain difficulties, raises many more. Into a statement of these difficulties we will not go here, but refer the reader to a brief and scholarly putting of them in Peake's *Critical Intro to the NT*, 12-16 (New York, Scribners, 1910).

There is accordingly today a manifest tendency among all scholars, including those in the more radical camps, to return to the traditional position concerning the authorship. The following are some of the positive arguments for the authenticity:

As for the opposing views of the coming of Christ in the two Epp., it is to be noted that precisely the same superficial contradiction occurs in Our Lord's own teaching on this same subject (Mt 24 6.23.24. 25.26; Lk 12 35.40). Jesus exhorts His disciples to watch, for in such an hour as they think not the Son of man cometh, and yet at the same time and in the same connection warns them that when they see certain signs they should not be troubled, for the end is not yet. Paul, brooding over the subject after writing the First Letter, might easily have come strongly to see the obverse side of the shield. The apostle built his theology upon the tradition which had come from Jesus as interpreted by its practical effects upon his converts, and his mind was quick to counteract any danger due to overemphasis or wrong inferences. He was not nearly as eager for a consistently stated doctrine as he was for a doctrine that made for spiritual life and efficiency. During the fierce persecutions at the beginning of the movement in Thessalonica, the comfort of the thought of the swift coming of Christ was in need of emphasis, but as soon as the doctrine was used as an excuse for unhealthful religious excitement the minds of the disciples must be focused on more prosaic and less exciting aspects of reality.

That Paul assumes a commanding and peremptory attitude in the Second Letter which we do not find so

plainly asserted in the First is readily admitted. Why should not the First Letter have had its intended effect upon the Thessalonian church as a whole? And if Paul received word that his gracious and tactful message had carried with it the conviction of the dominant elements of the church, but that certain groups had continued to be fanatical and disorderly, we can easily see how, with the main current of the church behind him, he would have dared to use more drastic methods with the offending members.

It is also readily admitted that the Second Letter is not so delightful and heart-warming as the First. It was plainly not written in a mood of such high emotional elevation. But the question may be raised as to whether the coaxing, caressing tone of the First Ep. would have been appropriate in handling the lazy and fanatical elements of the church after it had persisted in disregarding his tender and kindly admonitions. Jesus' stern words to the Pharisees in Mt 23 are not so inspiring as Jn 14, but they were the words and the only words that were needed at the time. "Let not your heart be troubled" would not be inspired if delivered to hypocrites. Furthermore, we are not called upon to assume that Paul at all times lived in the same mood of emotional exaltation. Indeed his Epp. abound with assertions that this was not the case (2 Cor 1 8; 1 Thess 3 9), and it is unreasonable to expect him always to write in the same key. It must be added, however, that the suggestion that the Second Ep. is stern may easily be overdone. If 1 Thess were not before us, it would be the tenderness of Paul's treatment of the church which would most impress us.

Harnack has recently added the weight of his authority to the argument for the Pauline authorship of the letter. He thinks that there were two distinct societies in Thessalonica, the one perhaps meeting in the Jewish quarter and composed chiefly of Jewish Christians, and the other composed of Greeks meeting in some other part of the city. In addition to the probability that this would be true, which arises from the very diverse social classes out of which the church was formed (Acts 17 4), and the size of the city, he points to the adoration in the First Letter (1 Thess 5 27) that this Ep. be read unto all the brethren, as a proof that there was a coterie in the church that met separately and that might easily have been neglected by the rest, just as the Greeks in Jerus were neglected in the daily ministrations (Acts 6 1). He thinks that the Second Letter was probably directed to the Jewish element of the church.

It is to be noted also that Professor Moffatt (*Intro to the Lit. of the NT*, 76 ff.), who calls in question the authenticity of nearly all of the books of the NT that any reputable scholars now attack, finds no sufficient reason to question the Pauline authorship of 2 Thess.

**III. The Man of Sin.**—The question as to whom or what Paul refers to in 2 1-12, when he speaks of the man of sin, whose revelation is 1. **Primary Reference** to precede the final manifestation of Christ, has divided scholars during all the Christian centuries. (For a good discussion of the history of the interpretation of this difficult section, see Findlay, "I and II Thess," *Cambridge Bible*, 170-80.) The reason why each age has had its fresh interpretation identifying the man of sin with the blasphemous powers of evil then most active is the fact that the prophecy has never yet found its complete accomplishment. The man of sin has never been fully revealed, and the Christ has never finally destroyed him.

But Paul says that the mystery of iniquity already works (2 7), and he tells the church that the restraining influence which for the time being held it in check is something that "ye know" (2 6). Plainly, then, the evil power and that which held it in check were things quite familiar both to Paul and to his readers. We must therefore give the prophecy a 1st-cent. reference. The alternative probably lies between making the mystery of iniquity the disposition of the Rom emperor to give himself out as an incarnation of deity and force all men to worship him, a tendency which was then

being held in check by Claudius, but which soon broke out under Caligula (see Peake's *Intro* above cited); or, on the other hand, making the mystery of iniquity to be some peculiar manifestation of diabolism which was to break out from the persecuting Jewish world, and which was then held in check by the restraining power of the Rom government.

In favor of making a blasphemous Rom emperor the man of sin, may be urged the fact that it was this demand of the emperor for worship which brought matters to a crisis in the Rom world and turned the terrific enginery of the Rom empire against Christianity. And it may be argued that it is hardly likely that the temporary protection which Paul received from the Rom government prevented him from seeing that its spirit was such that it must ultimately be ranged against Christianity. One may note also, in arguing for the Rom reference of the man of sin, the figurative and enigmatic way in which Paul refers to the opposing power, a restraint that would be rendered necessary for reasons of prudence (cf Mk 13 14, and also the cryptograms used by the author of the Book of Rev in referring to Rome). Paul has none of this reserve in referring to the persecuting Jewish world who "please not God, and are contrary to all men" (1 Thess 2 15). And in view of the fact that the Jews were in disfavor in the Rom empire, as is proved by the then recently issued decree of Claudius commanding all Jews to depart from Rome (Acts 18 2), and by the fact that to proclaim a man a Jew helped at that time to lash a mob into fury against him (Acts 16 20; 19 34), it would seem hardly likely that Paul would expect the subtle and attractive deception that was to delude the world to come from Jerus; and particularly would this seem unlikely in view of the fact that Paul seems to be familiar with Our Lord's prophecy of the swift destruction of Jerus, as is shown by his assertion in 1 Thess 2 16, that wrath is come upon them to the uttermost.

On the other hand, however, to make the man of sin a person or an influence coming from Judaism is supported by the fact that he is to sit in the temple of God, setting himself forth to be God (1 Thess 2 4), and by the fact that the natural punishment for the rejection of their Messiah was that the Jews should be led to accept a false Messiah. Having opposed Him who came in the Father's name, they were doomed to accept one who came in his own name. Again, and far more important than this, is the fact that during nearly the whole of Paul's life it was the Rom empire that protected him, and the unbelieving Jews that formed the malicious, cunning and powerful opposition to his work and to the well-being and peace of his churches, and he could very well have felt that the final incarnation of evil was to come from the source which had crucified the Christ and which had thus far been chiefly instrumental in opposing the gospel. Moreover, this expectation that a mysterious power of evil should arise out of the Jewish world seems to be in harmony with the rest of the NT (Mt 24 5. 23. 24; Rev 11 3. 7. 8). It is the second alternative, therefore, that is, with misgivings, chosen by the present writer.

It may be objected that this cannot be the true interpretation, as it was not fulfilled, but, on the contrary, it was Rome that became the gospel's most formidable foe. But this type of objection, if accepted as valid, practically puts a stop to all attempts at a historical interpretation of prophecy. It would force us to deny that the prophecies of the OT, which are usually taken as referring to Christ, referred to Him at all, because plainly they were not literally fulfilled in the time and manner that the prophets expected them to be fulfilled. It would almost force us to deny that John the Baptist referred to Christ when he heralded the coming of the one

who would burn up the chaff with unquenchable fire, because as the Gospels tell us Jesus did not fulfil this prophecy in the way John expected (Lk 7 19). See **MAN OF SIN**.

Although Paul's prediction concerning the man of sin was not literally fulfilled, nevertheless his teaching has a permanent significance. It is always true in every battle for good that the Son of man does not come until the falling away comes and the man of sin is revealed. First, there is the fresh tide of enthusiasm and the promise of swift victory for the kingdom of heaven, but soon there is the reaction and the renaissance

of opposition in new and overwhelming power. The battle is to the death. And then above the smoke of the battle men see the sign of the coming of the Son of man with power and great glory; the conviction floods them that after all what Christ stands for is at the center of the universe and must prevail, and men begin to recognize Christ's principles as though they were natural law. This action and reaction followed by final victory takes place in practically all religious and reforming movements which involve the social reconstruction of society according to the principles of the Kingdom. It is exceedingly important that men should be delivered from shallow optimism. And this Ep. makes its contribution to that good end.

**IV. Paul's Exhortation to Quiet Industry.**—The exhortation that the brethren should work with quietness and earn their own bread (3 12) is full of interest to those who are studying the psychological development of the early Christians under the influence of the great mental stimulus that came to them from the gospel. Some were so excited by the new dignity that had come to them as members of the Christian society, and by the new hopes that had been inspired in their minds, that they considered themselves above the base necessity of manual labor. This is not an infrequent phenomenon among new converts to Christianity in heathen lands. Paul would have none of it. Fortunately he could point to his own example. He not only labored among them to earn his own livelihood, but he worked until muscles ached and body rebelled (2 Thess 3 8).

Paul saw that the gospel was to be propagated chiefly by its splendid effects on the lives of all classes of society, and he realized that almost the first duty of the church was to be respected, and so he not only exhorts the individual members to independence, but he lays down the principle that no economic parasite is to be tolerated in the church. "If any man will not work, neither let him eat" (3 10). This forms an important complement to the teaching of Jesus (Mt 5 42): "Give to him that asketh thee, and from him that would borrow of thee turn not thou away."

**LITERATURE.**—See under 1 Thess.

ROLIN HOUGH WALKER

**THESSALONICA**, thes-a-lō-ni'ka (Θεσσαλονίκη, *Thessalonikē*, ethnic Θεσσαλονικεύς, *Thessalonikeús*):

One of the chief towns of Macedonia and the present day. It lies in 40° 40' N. lat., and 22° 50' E. long., at the northernmost point of the Thermaic Gulf (Gulf of Salonica), a short distance to the E. of the mouth of the Axios (*Vardar*). It is usually maintained that the earlier name of Thessalonica was Therma or Therme, a town mentioned both by Herodotus (vii.121 ff, 179 ff) and by Thucydides (i.61; ii.29), but that its chief importance dates from about 315 BC, when the Macedonian king Cassander, son of Antipater, enlarged and strengthened it by con-

centrating there the population of a number of neighboring towns and villages, and renamed it after his wife Thessalonica, daughter of Philip II and step-sister of Alexander the Great. This name, usually shortened since mediaeval times into Salonica or Saloniki, it has retained down to the present. Pliny, however, speaks of Therma as still existing side by side with Thessalonica (*NH*, iv.36), and it is possible that the latter was an altogether new foundation, which took from Therma a portion of its inhabitants and replaced it as the most important city on the Gulf.

Thessalonica rapidly became populous and wealthy. In the war between Perseus and the

Romans it appears as the headquarters of the Macedonian navy (Livy xlv.10) and when, after the battle of Pydna (168 BC), the Romans divided the conquered territory into four districts, it became the capital of the second of these (Livy xlv.29), while later, after the organization of the single Rom province of Macedonia in 146 BC, it was the seat of the governor and thus practically the capital of the whole province. In 58 BC Cicero spent the greater part of his exile there, at the house of the quaestor Plancius (*Pro Plancio* 41, 99; *Ep. Ad Att.* iii.8-21). In the civil war between Caesar and Pompey, Thessalonica took the senatorial side and formed one of Pompey's chief bases (49-48 BC), but in the final struggle of the republic, six years later, it proved loyal to Antony and Octavian, and was rewarded by receiving the status and privileges of a "free city" (Pliny, *NH*, iv.36). Strabo, writing in the reign of Augustus, speaks of it as the most populous town in Macedonia and the metropolis of the province (vii.323, 330), and about the same time the poet Antipater, himself a native of Thessalonica, refers to the city as "mother of all Macedon" (Jacobs, *Anthol. Graec.*, II, p. 98, no. 14); in the 2d cent. of our era Lucian mentions it as the greatest city of Macedonia (*Asinus*, 46). It was important, not only as a harbor with a large import and export trade, but also as the principal station on the great Via Egnatia, the highway from the Adriatic to the Hellespont.

Paul visited the town, together with Silas and Timothy, on his 2d missionary journey. He had been at Philippi, and traveled thence

**3. Paul's** by the Egnatian Road, passing through Amphipolis and Apollonia on the way

(Acts 17 1). He found at Thessalonica a synagogue of the Jews, in which for three successive Sabbaths he preached the gospel, basing his message upon the types and prophecies of the OT Scriptures (vs 2.3). Some of the Jews became converts and a considerable number of proselytes and Greeks, together with many women of high social standing (ver 4). Among these converts were in all probability Aristarchus and Secundus, natives of Thessalonica, whom we afterward find accompanying Paul to Asia at the close of his 3d missionary journey (Acts 20 4). The former of them was, indeed, one of the apostle's most constant companions; we find him with Paul at Ephesus (Acts 19 29) and on his journey to Rome (Acts 27 2), while in two of his Epp., written during his captivity, Paul refers to Aristarchus as still with him, his fellow-prisoner (Col 4 10; Philem ver 24). Gaius, too, who is mentioned in conjunction with Aristarchus, may have been a Thessalonian (Acts 19 29). How long Paul remained at Thessalonica on his 1st visit we cannot precisely determine; certainly we are not to regard his stay there as confined to three weeks, and Ramsay suggests that it probably extended from December, 50 AD, to May, 51 AD (*St. Paul the Traveller*, 228). In any case, we learn that the Philippians sent him assist-

ance on two occasions during the time which he spent there (Phil 4 16), although he was "working night and day" to maintain himself (1 Thess 2 9; 2 Thess 3 8). Paul, the great missionary strategist, must have seen that from no other center could Macedonia be permeated with the gospel so effectively as from Thessalonica (1 Thess 1 8).

But his success roused the jealousy of the Jews, who raised a commotion among the dregs of the city populace (Acts 17 5). An attack was made on the house of Jason, with whom the evangelists were lodging, and when these were not found Jason himself and some of the other converts were dragged before the magistrates and accused of harboring men who had caused tumult throughout the Rom world, who maintained the existence of another king, Jesus, and acted in defiance of the imperial decrees. The magistrates were duly alive to the seriousness of the accusation, but, since no evidence was forthcoming of illegal practices on the part of Jason or the other Christians, they released them on security (vs 5-9). Foreseeing further trouble if Paul should continue his work in the town, the converts sent Paul and Silas (and possibly Timothy also) by night to Beroea, which lay off the main road and is referred to by Cicero as an out-of-the-way town (*oppidum devium: in Pisonem* 36). The Beroean Jews showed a greater readiness to examine the new teaching than those of Thessalonica, and the work of the apostle was more fruitful there, both among Jews and among Greeks (vs 10-13). But the news of this success reached the Thessalonian Jews and inflamed their hostility afresh. Going to Beroea, they raised a tumult there also, and made it necessary for Paul to leave the town and go to Athens (vs 14.15).

Several points in this account are noteworthy as illustrating the strict accuracy of the narrative of the Acts. Philippi was a Rom town, military rather than commercial; hence we find but few Jews there and no synagogue; the magistrates bear the title of praetors (Acts 16 20.22.35.36.38 RVm) and are attended by lictors (Acts 16 35.38 RVm); Paul and Silas are charged with the introduction of customs which Romans may not observe (ver 21); they are beaten with rods (vs 22) and appeal to their privileges as Rom citizens (vs 37.38). At Thessalonica all is changed. We are here in a Gr commercial city and a seaport, a "free city," moreover, enjoying a certain amount of autonomy and its own constitution. Here we find a large number of resident Jews and a synagogue. The charge against Paul is that of trying to replace Caesar by another king; the rioters wish to bring him before "the people," i.e. the popular assembly characteristic of Gr states, and the magistrates of the city bear the Gr name of politarchs (Acts 17 5-9). This title occurs nowhere in Gr lit., but its correctness is proved beyond possibility of question by its occurrence in a number of inscriptions of this period, which have come to light in Thessalonica and the neighborhood, and will be found collected in *AJT* (1898, 598) and in M. G. Dimitzas, *Makedonia (Makedonia)*, 422 ff. Among them the most famous is the inscription engraved on the arch which stood at the western end of the main street of Salonica and was called the Vardar Gate. The arch itself, which was perhaps erected to commemorate the victory of Philippi, though some authorities assign it to a later date, has been removed, and the inscription is now in the British Museum (*CIG*, 1967; Leake, *Northern Greece*, III, 236; Le Bas, *Voyage archéologique*, no. 1357; Vaux, *Trans. Royal Soc. Lit.*, VIII, 528). This proves that the politarchs were six in number, and it is a curious coincidence that in it occur the names Sosipater, Gaius and Secundus, which are borne by three Macedonian converts, of whom the first two were probably Thessalonians, the last certainly.

The Thessalonian church was a strong and flourishing one, composed of Gentiles rather than of Jews, if we may judge from the

4. The Thessalonian Church from and allusions to the OT, and the phrase "Ye turned unto God from idols" (1 Thess 1 9; cf also 2 14). These, by common consent the earliest of Paul's Epp., show us that the apostle was eager

to revisit Thessalonica very soon after his enforced departure: "once and again" the desire to return was strong in him, but "Satan hindered" him (2 18)—a reference probably to the danger and loss in which such a step would involve Jason and the other leading converts. But though himself prevented from continuing his work at Thessalonica, he sent Timothy from Athens to visit the church and confirm the faith of the Christians amid their hardships and persecutions (3 2-10). The favorable report brought back by Timothy was a great comfort to Paul, and at the same time intensified his longing to see his converts again (3 10.11). This desire was to be fulfilled more than once. Almost certainly Paul returned there on his 3d missionary journey, both on his way to Greece (Acts 20 1) and again while he was going thence to Jerus (ver 3); it is on this latter occasion that we hear of Aristarchus and Secundus accompanying him (ver 4). Probably Paul was again in Thessalonica after his first imprisonment. From the Ep. to the Phil (1 26; 2 24), written during his captivity, we learn that his intention was to revisit Philippi if possible, and 1 Tim 1 3 records a subsequent journey to Macedonia, in the course of which the apostle may well have made a longer or shorter stay at Thessalonica. The only other mention of the town in the NT occurs in 2 Tim 4 10, where Paul writes that Demas has forsaken him and has gone there. Whether Demas was a Thessalonian, as some have supposed, cannot be determined.

For centuries the city remained one of the chief strongholds of Christianity, and it won for itself the title of "the Orthodox City," not only by the tenacity and vigor of its resistance to the successive attacks of various barbarous races, but also by being largely responsible for their conversion to Christianity.

From the middle of the 3d cent. AD it was entitled "metropolis and colony," and when Diocletian (284-305) divided Macedonia into two provinces, Thessalonica was chosen as the capital of the first of these. It was also the scene in 390 AD of the famous massacre ordered by Theodosius the Great, for which Ambrose excluded that emperor for some months from the cathedral at Milan. In 253 the Goths had made a vain attempt to capture the city, and again in 479 Theodoric, king of the Ostrogoths, found it so strong and well prepared that he did not venture to attack it. From the 6th to the 9th cent. it was engaged in repeated struggles against Avars, Slavonians and Bulgarians, whose attacks it repelled with the utmost difficulty. Finally, in 904 AD it was captured by the Saracens, who, after slaughtering a great number of the inhabitants and burning a considerable portion of the city, sailed away carrying with them 22,000 captives, young men, women and children. In 1185, when the famous scholar Eustathius was bishop, the Normans under Tancred stormed the city, and once more a general massacre took place. In 1204 Thessalonica became the center of a Latin kingdom under Boniface, marquis of Monferrat, and for over two centuries it passed from hand to hand, now ruled by Latins now by Greeks, until in 1430 it fell before the sultan Amurath II. After that time it remained in the possession of the Turks, and it was, indeed, the chief European city of their dominions, with the exception of Constantinople, until it was recaptured by the Greeks in the Balkan war of 1912. Its population includes some 32,000 Turks, 47,000 Jews (mostly the descendants of refugees from Spain) and 16,000 Greeks and other Europeans. The city is rich in examples of Byzantine ecclesiastical architecture and art, and possesses, in addition to a large number of mosques, 12 churches and 25 synagogues.

LITERATURE.—The fullest account of the topography of Thessalonica and its history, esp. from the 5th to the 15th cent., is that of Tafel, *De Thessalonica eiusque agro. Dissertatio geographica*, Berlin, 1839; cf also the Histories of Gibbon and Finlay. A description of the town and its ancient remains is given by Leake, *Travels in Northern Greece*, III, 235 ff; Cousinier, *Voyage dans la Macédoine*, I, 23 ff; Heuzey, *Mission archéol. de Macédoine*, 272 ff; and other travelers. The inscriptions, mostly in Gr, are collected in Dimitzas, *Makedonia (Makedonia)*, 421 ff.

M. N. Ton

**THEUDAS**, thū'das (Θευδάς, *Theudás*, a contraction of Theodorus, "the gift of God"); Theudas is referred to by Gamaliel in his speech before the Sanhedrin, when he advised them as to the position they should adopt in regard to the apostles (Acts 5 36). The failure of the rebellion of Theudas was quoted by Gamaliel on this occasion as typical of the natural end of such movements as were inspired "not of God, but of men." A rising under one Theudas is also described by Jos (*Ant.*, XX, v, 1), but this occurred at a later date (according to Jos about 44 or 45 AD) than the speech of Gamaliel (before 37 AD). Of the theories put forward in explanation of the apparent anachronism in Gamaliel's speech, the two most in favor are (1) that as there were many insurrections during the period in question, the two writers refer to different Theudas; (2) that the reference to Theudas in the narrative of Acts was inserted by a later reviser, whose historical knowledge was inaccurate (Weiss; cf also Knowling, *Expos Gr Test.*, II, 157-59).

C. M. KERR

**THICK TREES** (עֵץ עָבֹה, 'ēc 'ābhōth [Lev 23 40; Neh 8 15]): One of the varieties of trees which the Israelites were directed to use at the Feast of Tabernacles; in the latter passage they are expressly directed to make booths with them. According to the Talmudic writings, the "thick trees" are myrtles (*Suk.* 12a; *Jer Suk.* iii, 53d), and further tradition has prescribed certain special features as to the varieties of myrtle employed, without which they cannot be used in the ritual of the feast. In Sir 14 18 "thick tree" represents δένδρον δασύ, *déndron dasú*, "leafy tree." See MYRTLE.

**THICKET**, thik'et (תְּבֵיבִים, *tēbhākh* [Gen 22 13; Isa 9 18; 10 34], or תְּבֵיבִים, *tēbhēkh* [Jer 4 7]; in 1 S 13 6, תְּבֵיבִים, *tēbhē*): A thick or dense growth of trees or shrubs (thorns, brambles), in which wild beasts may lurk (Jer 4 7), or animals be caught by their horns (Gen 22 13; Abraham's ram). See FOREST.

**THIEF**, thēf: In the OT the uniform tr (17 t) of גַּנָּב, *gannābh*, from *gānabh*, "steal," but *gannābh* is rather broader than the Eng. "thief," and may even include a kidnapper (Dt 24 7). In Apoc and the NT, AV uses "thief" indifferently for κλέπτης, *klēptēs*, and ληστής, *lēstēs*, but RV always renders the latter word "robber" (a great improvement). See CRIMES. The figurative use of "thief" as "one coming without warning" (Mt 24 43, etc) needs no explanation.

The penitent thief ("robber," RV Mk 15 27; Mt 27 38.44; "malefactor," Lk 23 32.39) was one of the two criminals crucified with Christ. According to Mk and Mt, both of these joined in the crowd's mockery, but Lk tells that one of them reproached his fellow for the insults, acknowledged his own guilt, and begged Christ to remember him at the coming of the Kingdom. And Christ replied by promising more than was asked—immediate admission into Paradise. It should be noted that unusual moral courage was needed for the thief to make his request at such a time and under such circumstances, and that his case has little in common with certain sentimental "death-bed repentances."

To explain the repentance and the acknowledgment of Christ as Messiah, some previous acquaintance of the thief with Christ must be supposed, but all guesses as to time and place are of course useless. Later tradition abundantly filled the blanks and gave the penitent thief the name Titus or Dysmas. See ASSASSINS; BARABBAS.

BURTON SCOTT EASTON

**THIGH**, thī (יָרֵךְ, *yārēkh*; Aram. יַרְכָּה, *yar'khāh* [Dnl 2 32]; μῆρός, *mērós* [Jth 9 2; Sir 19 12; Rev 19 16]; as part of a sacrificial animal [Ex 29 22, etc] שֵׁוֹק, *shōk*, AV, RVm "shoulder"; in addition AV has "thigh" for *shōk* in Isa 47 2 [RV "leg?"]): The portion of the leg from the knee to the hip, against which a weapon hangs when suspended from the waist (Ex 32 27; Jgs 3 16.21; Ps 45 3, etc). So the thigh of a rider on horseback would be covered by a loose girdle, on which his name might be embroidered (Rev 19 16). The "hollow of the thigh" (Gen 32 25 ff) is the hip-socket or the groin. See also HIP.

The thighs were thought to play a part in procreation (Gen 46 26; Ex 1 5, EV "loins"; Jgs 8 30, EV "body"; cf Nu 5 21 ff), so that an oath taken with the hand under the thigh (Gen 24 2.9; 47 29) was taken by the life-power (the rabbis interpreted "by the seal of circumcision"). It is perhaps significant that this oath in both Gen 24 and 47 is said to have been exacted by persons in danger of death. Doubtless this association of the thigh with life (aided perhaps by its excellence as food [1 S 9 24; Ezk 24 4]) determined its choice as a sacrificial portion (Ex 29 22, etc; on the "heave thigh" see SACRIFICE). Consequently it is natural to find the thigh classed as forbidden ("sacred") food among certain peoples, and, probably, this sacred character of the part is the real basis of Gen 32 32: "The children of Israel eat not the sinew of the hip which is upon the hollow of the thigh, unto this day." The origin of the prohibition, however, was unknown to the writer of the verse, and he sought an explanation from a story in which special attention was called to the thigh. Nothing else is heard about this precept in the OT, but it receives elaborate attention in the Mish (*Hullin*, vii), where, for instance, all food cooked with meat containing the sinew (*nervus ischiadicus*) is rendered unclean if the sinew imparts a flavor to it, but not otherwise. (For further details see the comms., esp. Skinner [ICC] and RS<sup>2</sup>, 380.) One of the proofs of guilt in the jealousy trial (Nu 5 27) was the falling-away of the "thigh" (a euphemism; see JEALOUSY). To smite upon the thigh was a token of contrition (Jer 31 19) or of terror (Ezr 21 12).

BURTON SCOTT EASTON

**THIMNATHAH**, thim-na-thā, thim-nā-tha (תִּמְנַתָּה, *timnāthāh*): AV in Josh 19 43. It is correctly "Timnah" with Hē locale meaning "toward Timnah." See TIMNAH.

**THINK**, think: The OT often translates אָמַר, 'amar, "to say," meaning what one says to himself, and hence a definite and clearly formulated decision or purpose (Gen 20 11; Nu 24 4; Ruth 4 4, etc), illustrated by the change made by RV in AV of Est 6 6, where "thought in his heart" becomes "said in his heart." In other passages, for הָשִׁיב, *hāshabbh*, הָשִׁיב, *dāmāh*, or זָמַם, *zāmam*, indicating the result of mental activity, as in an intention or estimate formed after careful deliberation (cf Eccles 18 25). In the NT, most frequently for δοκέω, *dokeō*, "to be of the opinion," "suppose," lit. "seem" (Mt 3 9; 6 7; Lk 10 36, etc). Sometimes, for λογίζομαι, *logizomai*, "to compute," "reckon" (Rom 2 3, etc); sometimes, for νομίζω, *nomízō*, lit. referring to what attains the force of law (*nómos, nōmos*), and then, "to be of the opinion"; or, for φρονέω, *phronēō*, implying a thought that is cherished—a mental habit, rather than an act (Rom 12 3; 1 Cor 13 11). The Gr ἡγέομαι, *hēgēomai*, "to consider," implies logical deduction from premises (Acts 26 2; Phil 2 6), while in Mt 1 20; 9 4, and Acts 10 19, ἐνθυμούμαι, *enthumōomai*, refers



to the mental process itself, the thinking-out of a project, the concentration of the faculties upon the formation of a plan.  
H. E. JACOBS

**THIRD**, thúrd (תְּשִׁישִׁי, *shēlīshī*; τρίτος, *trítos*): Isa 19 24, "In that day shall Israel be the third with Egypt and with Assyria," etc, brings out very distinctly the universal and missionary character of Isaiah's prophecies and of Israel's destiny (cf Ezk 16 63; and see G. A. Smith, *Isaiah*, II, 275, 278; Watkinson, *The Blind Spot*, 21 ff).

For "third hour," "third month," "third year," see CALENDAR; DAY; TIME.

**THIRD DAY.** See LORD'S DAY.

**THIRST**, thúrst (צָמָה, *cāmā*, vb. צָמַח, *cāmē*; διψάω, *dipsáō*, δίψος, *dīpsos*, δίψα, *dīpsa*): One of the most powerful natural appetites, the craving for water or other drink. Besides its natural significance, thirst is figuratively used of strong spiritual desire. The soul thirsts for God (Ps 42 2; 63 1). Jesus meets the soul's thirst with water of life (Jn 4 13 ff; 6 35; 7 37). It is said of the heavenly bliss, "They shall hunger no more; neither thirst any more" (Rev 7 16.17; cf Isa 49 10).

**THIRTEEN**, thúr'tēn, thúr-tēn', **THIRTY**, thúr'ti. See NUMBER.

**THISBE**, thiz'bē (Β, Θισβη, *Thisbē*, Α, Θιβη, *Thibē*): The home of Tobit whence he was carried into captivity to Babylon. It is said to be "on the right hand [i.e. S.] of Kedesh-naphtali in Galilee" (Tob 1 2). Some have thought that this was the native place of Elijah the Tishbite, but this is mere conjecture. The site has not been recovered. We need not expect strict geographical accuracy in the romance of Tobit, any more than in that of Judith.

**THISTLES**, thís'lz. See THORNS.

**THOCANUS**, thō-kā'nus (Θόκανος, *Thókanos*, Θόκανος, *Thókanos*; AV Theocanus): The father of Ezekias, who with Jonathan "took the matter upon them" in the proceedings under Ezra against foreign wives (1 Esd 9 14) = "Tikvah" in Ezr 10 15.

**THOMAS**, tom'as (Θωμάς, *Thōmās*; דָּוִד, *tā'ōm*, "a twin" (in pl. only): One of the Twelve Apostles. Thomas, who was also called

1. In the "Didymus" or "the Twin" (cf Jn 11 16; NT 20 24; 21 2), is referred to in detail by the Gospel of Jn alone. His election to the Twelve is recorded in Mt 10 3; Mk 3 18; Lk 6 15; Acts 1 13. In Jn 11 1-54, when Jesus, despite imminent danger at the hands of hostile Jews, declared His intention of going to Bethany to heal Lazarus, Thomas alone opposed the other disciples who sought to dissuade Him, and protested, "Let us also go; that we may die with him" (11 16). On the eve of the Passion, Thomas put the question, "Lord, we know not whither thou goest; how know we the way?" (14 5). After the crucifixion, Thomas apparently severed his connection with the rest of the apostles for a time, as he was not present when the risen Christ first appeared to them (cf 20 24). But his subsequent conversation with them, while not convincing him of the truth of the resurrection—"except I shall see . . . I will not believe" (20 25)—at least induced him to be among their number eight days afterward (20 26) in the upper room. There, having received the proofs for which he sought, he made the confession, "My Lord and my God"

(20 28), and was reproved by Jesus for his previous unbelief: "Because thou hast seen me, thou hast believed: blessed are they that have not seen, and yet have believed" (20 29). He was one of the disciples to whom Jesus manifested Himself during the fishing expedition at the Sea of Tiberias (21 1-11).

According to the "Genealogies of the Twelve Apostles" (cf Budge, *The Contendings of the Apostles*, II, 50), Thomas was of the house of Asher. The oldest accounts are to the effect that he died a natural death (cf Clement of Alexandria iv.9, 71). Two fields are mentioned by apocryphal literature as the scene of Thomas' missionary labors. (1)

2. In Apocryphal Literature According to Origen, he preached in Parthia, and according to a Syrian legend he died at Edessa. The Agbar legend also indicates the connection of Thomas with Edessa. But Eusebius indicates it was Thaddaeus and not Thomas who preached there (see THADDAEUS). (2) Along with these are other sources identifying Thomas with India. Thus "The Acts of Thomas" (see APOCRYPHAL ACTS, B, V), a gnostic work dating from the 2d cent., tells how when the world was partitioned out as a mission field among the disciples, India fell to "Judas Thomas, also called Didymus," and narrates his adventures on the way, his trials, missionary success, and death at the hands of Misdai, king of India (cf Budge, II, 404 ff; Hennecke, *Neutestamentliche Apokryphen*, 473-544; Pick, *The Apocryphal Acts*, 224 ff). The "Preaching of St. Thomas" (cf Budge, II, 319) relates still more fantastic adventures of Thomas in India, and the "Martyrdom of St. Thomas in India" states that on his departure toward Macedonia he was put to death as a sorcerer.

Of the two, the former is the more probable. An attempt at reconciliation has been made by supposing that the relics of Thomas were transported from India to Edessa, but this is based on inaccurate historical information (cf Hennecke, op. cit., 474). The additional names "Judas" and "Didymus" have caused further confusion in apocryphal literature in regard to Thomas, and have led to his identification with Judas of James, and hence with Thaddaeus (see THADDAEUS), and also with Judas the brother of Jesus (cf Mt 13 55). Thus in the "Acts of Thomas" he is twice called the "twin brother of the Messiah." Another legend makes Lysia the twin sister of Thomas. A gnostic "Gospel of Thomas" (see APOCRYPHAL GOSPELS, III, 2, [a]) was known to Irenaeus (cf Iren., *Adv. Haer.*, i.20).

Although little is recorded of Thomas in the Gospels, he is yet one of the most fascinating of the apostles. He is typical of that nature

3. Character—a nature by no means rare—which contains within it certain conflicting elements exceedingly difficult of reconciliation. Possessed of little natural buoyancy of spirit, and inclined to look upon life with the eyes of gloom or despondency, Thomas was yet a man of indomitable courage and entire unselfishness. Thus with a perplexed faith in the teaching of Jesus was mingled a sincere love for Jesus the teacher. In the incident of Christ's departure for Bethany, his devotion to his Master proved stronger than his fear of death. Thus far, in a situation demanding immediate action, the faith of Thomas triumphed; but when it came into conflict with his standards of belief it was put to a harder test. For Thomas desired to test all truth by the evidence of his senses, and in this, coupled with a mind tenacious both of its beliefs and disbeliefs, lay the real source of his religious difficulties. It was his sincerity which made him to stand aloof from the rest of the disciples till he had attained to personal conviction regarding the resurrection; but his sincerity also drew from him the testimony to that conviction, "My Lord and my God," the greatest and fullest in all Christianity.  
C. M. KERR

**THOMAS, GOSPEL OF.** See APOCRYPHAL GOSPELS, III, 2, (a).

**THOMEI**, thom'ē-i (Α, Θομεί, *Thomei*, Fritzsche, Θομοί, *Thomoi*, B and Swete, Θομηί, *Thomhei*; AV Thomoi): A family name of temple-servants who returned with Zerubbabel (1 Esd 5 32) = "Temah" in Ezr 2 53; Neh 7 55.

**THORN**, thörn, **IN THE FLESH** (σκόλοψ τῆ σαρκί, *skólōps tē sarkí*): St. Paul thus characterizes some bodily ailment which afflicted him and impaired his usefulness (2 Cor 12 7). The data are insufficient to enable us to ascertain its real nature, and all the speculations on the point are therefore inconclusive. All that we are told is that it was a messenger of Satan; that thereby he was beaten as with a fist, which might be figurative or actual; that it rendered his bodily presence unattractive. It appears that the infirmity recurred, for thrice he sought deliverance; but, by the help of God, he was able to glory in it. Sir W. Ramsay sees in it some form of recurring malarial fever. It was something that disabled him (Gal 4 12-15); hence Farrar supposes that it was ophthalmia, from the reference to his eyes, from his inability to recognize the high priest (Acts 23 5), from his employing amanuenses to write his epp., and his writing the Galatian letter in large characters with his own hand (Gal 6 11). Krenkel has at great length argued that it was epilepsy, and thereby endeavors to account for his trances and his falling to the earth on his way to Damascus, but his work is essentially a special pleading for a foregone conclusion, and Paul would not have called his visions "a messenger of Satan." It is also beside the question to heap up instances of other distinguished epileptics. On the whole Farrar's theory is the most probable.

It is probably only a coincidence that "pricks in your eyes" (LXX *skólōpes*) are mentioned in Nu 33 55. Any pedestrian in Pal must be familiar with the ubiquitous and troublesome thorny shrubs and thistles which abound there.

ALEX. MACALISTER

**THORNS**, thörnz, **THISTLES**, ETC: There are very many references to various thorny plants in the Bible, and of the Heb words employed great uncertainty exists regarding their exact meaning. The alternative trs given in the text of EV and in the margin show how divided are the views of the translators. In the following list the suggestions given of possible species indicated, usually by comparison with the Arab., are those of the late Professor Post, who spent the best years of his life in study of the botany of Pal. In the great majority of instances, however, it is quite impossible to make any reasonable suggestion as to any particular species being indicated.

(1) אֲתָדָה, *'atādāh* (Jgs 9 14, EV "bramble," AVm "thistle," RVm "thorn"; Ps 58 9, EV "thorns"): Probably the buckthorn (*Rhamnus Palestina* Post). Atad occurs as a proper name in Gen 50 10.11.

(2) בִּרְקָנִים, *birkānīm* (Jgs 8 7.16, EV "briers"): Some thorny plant. The Egypt-Arab. *bargan* is, according to Moore (*Comm. on Jgs*), the same as *Centaurea scoparius* (N.O. *Compositae*), a common Palestinian thistle.

(3) דַּרְדָּר, *dardar* (Gen 3 18; Hos 10 8, EV "thistle"; LXX τριβόλος, *tribólos*): In Arab., *shauket ed-dardar* is a general name for the thistles known as *Centaureae* or star-thistles (N.O. *Compositae*), of which Pal produces nearly 50 species. The purple-flowered *C. calcitrapa* and the yellow *C. verutum* are among the commonest and most striking.

(4) הֶדְדֵק, *hedhek* (Prov 15 19, EV "thorns"; LXX ἀκανθα, *akántha*; Mic 7 4, EV "brier"): From former passages this should be some thorny plant suitable for making a hedge (cf Arab. *hadak*, "to inclose," "wall in"). Lane states that Arab. *hadak* is *Solanum sanctum*. Post suggests the oleaster, *Elaeagnus hortensis*.

(5) הַיִּת, *hō'hī*; LXX κνίδη, *knidē*, and ἀκανθα, *akántha* (2 K 14 9; Job 31 40, EV "thistle," m "thorn"; 2 Ch 25 18, EV "thistle," AVm "furze

bush," RVm "thorn"; Hos 9 6; Cant 2 2, EV "thorns"; Isa 34 13, AV "brambles," RV "thistles"; Prov 26 9, EV "a thorn"; 1 S 13 6, "thickets"; יִרְיִי, *hāwāhīm*, is, however, according to Driver and others a corruption for יִרְיִי, *hōrīm*, "holes"; Job 41 2, AV "thorn," RV "hook"; 2 Ch 33 11, AV "thorns," RV "in chains," m "with hooks"): Clearly *hō'hī* stands for some plant with very strong thorns, but it is quite impossible to say what species is intended; indeed, probably the word was used in a general way. See **HOOK**.

(6) מְסִיכָה, *mēsūkāh*, occurs only in Mic 7 4, where it means a "thorn hedge."

(7) נֶצְעִיץ, *na'ācūc* (Isa 7 19, AV "thorns," RV "thorn hedges"; Isa 55 13, EV "thorn"): The word is derived from נָצַץ, *nā'ac*, "to prick," or "pierce," and probably applies to any prickly plant. The LXX tr στροβή, *strobē* (Isa 55 13), suggests the thorny burnet, *Poterium spinosum*, so common in Pal (see **BOTANY**). Post says, "It may be one of the thorny acacias" (*HDB*, IV, 752).

(8) סִרְיִים, *sīrīm* (Ecl 7 6, "the cracking of thorns [sīrīm] under a pot" [sīr]; Isa 34 13, "Thorns shall come up in its palaces"; Hos 2 6, "I will hedge up thy way with thorns"; Nah 1 10, "Entangled like thorns [AV "folden together as thorns"] . . . they are consumed utterly as dry stubble"): The thorny burnet, *Poterium spinosum*, is today so extensively used for burning in ovens and limekilns in Pal that it is tempting to suppose this is the plant esp. indicated here. In Am 4 2 סִרְוֹת, *sīrōth*, is tr<sup>d</sup> "fish-hooks." See **HOOK**.

(9) סִלּוֹן, *šillōn* (Ezk 28 24, EV "brier");

סִלּוֹנִים, *šallōnīm* (Ezk 2 6, EV "thorns"): Arab. *šalla* = "thorn."

(10) סָרְבִיִּים, *sārābhīm* (Ezk 2 6, EV "briers," AVm "rebels"): The tr as a plant name is very doubtful.

(11) שִׁרְפָדָה, *šīrpādāh* (Isa 55 13, "Instead of the brier shall come up the myrtle-tree"): LXX has κόμυσα, *kómυsa*, which is (Post) the elecampane, *Inula viscosa* (N.O. *Compositae*), a plant 2 or 3 ft. high, growing on the bare hillsides of Pal, not infrequently in close association with the myrtle.

(12) צִנְנִים, *šinnīm* (Job 5 5; Prov 22 5, EV "thorns"); צִנְנִיָּה, *šinnīyāh* (Nu 33 55; Josh 23 13, EV "thorns"): The words apparently have a very general meaning.

(13) קִיץ, *kīc*; LXX ἀκανθα, *akántha*: A general name for thorny and prickly plants, the commonest in the OT (Gen 3 18; Ex 22 6; Jgs 8 7.16; 2 S 23 6; Ps 118 12; Isa 32 13; 33 12; Jer 4 3; 12 13; Ezk 28 24; Hos 10 8).

(14) קַמְרוֹשׁ, *kimmōsh* (Prov 24 31, "thorns"; Isa 34 13; Hos 9 6, "nettles"). See **NETTLES**.

(15) שִׁכְיִים, *sikkīm*, pl. of שִׁיךְ, *sēkh*, same as Arab. شوك, *shauk*, "a thorn" (Nu 33 55, "pricks").

(16) שַׁיִת, *shayīth*: A word peculiar to Isa (5 6; 7 23 ff; 9 18; 10 17; 27 4) and always associated with *shāmīr* (see [17]), always tr<sup>d</sup> "thorns."

(17) שַׁמִּיר, *shāmīr*: References as above (16), and in Isa 32 13, where it is with *kīc* (see [13]) always tr<sup>d</sup> "briers." The Arab. *samur* is the thorny acacia *A. seyyal* and *A. tortilis* (Post).

(18) ἀκανθος, *akánthos*: The equivalent of *kīc* (see [13]) (Mt 7 16; 13 7.22; 27 29, etc). Always tr<sup>d</sup> "thorns."

(19) ῥάμνος, *rhāmnos* (Bar 6 71, "white thorn"): The *Rhamnus Palestina*.

(20) σκόλοψ, *skólōps* (2 Cor 12 7, EV "thorn," m "stake"). See **THORN IN THE FLESH**.

(21) *tribolos*, *tribolos* (Mt 7 16, "thistle"; He 6 8, AV "briers," RV "thistles").

The extraordinary plentifulness of various prickly plants in Pal—in its present condition—is evident to any traveler during the summer months. Many of the trees and shrubs are thorny and the ground is everywhere covered thick with thistles, many of which are very handsome and some of which attain a height of 6 or 8 ft. Before the peasant can plough, he must clear these away by burning (cf Isa 10 17). The early autumn winds often drive before them in revolving mass some of the star-thistles—a sight so characteristic that it may be the "thistle down" (AVm, RV "whirling dust") of Isa 17 13. Thorns and thistles are described (Gen 3 18) as God's curse on the ground for sin. The Talm suggests that these must be edible and are therefore artichokes. The removal of them and the replacement by more useful plants is a sign of God's blessing (Isa 55 13; Ezk 28 24).

Gen 3 18 uses the words קִיץ and דָּרְדָר for "thorns" and "thistles." *Midhrāsh Rabbā'* to Genesis (*Midr. Gen. Rabbā'* 20 10) says that קִיץ ("thorn") is the same as עֲקָבִית (*akkābhith*), which means an edible thistle (cf Levy, *Dict.*, 645), and that דָּרְדָר (*dardar*, "thistle") is the same as קִינְרָס (*kinras*; Gr *κυνάρα*, *kunāra*, "artichoke") (cf Levy, *Dict.*, 298). "But," adds the *Midhrāsh*, "some reverse it, and say that דָּרְדָר (*dardar*) is עֲקָבִית (*akkābhith*) and that קִיץ (*kōg*) is קִינְרָס (*kinras*)."

The neglected vineyard of the sluggard "was all grown over with thorns, the face thereof was covered with nettles" (Prov 24 31), and in God's symbolic vineyard "there shall come up briars and thorns" (Isa 5 6); "They have sown wheat and have reaped thorns; they have put themselves to pain, and profit nothing" (Jer 12 13).

Jotham compares the usurper Abimelech to a bramble (*Rhamnus Palaestina*) (Jgs 9 14 f), and Jehoash, king of Israel, taunted Amaziah, king of Judah, by comparing him slightly to a thistle (m "thorn"), readily trodden down by a wild beast (2 K 14 9).

Nevertheless thorns and thistles have their uses. On them the goats and camels browse; scarcely any thorns seem to be too sharp for their hardened palates. The thorny burnet (*Poterium spinosum*), Arab. *ballān*, which covers countless acres of bare hillside, is used all over Pal for ovens (Ecl 7 6) and lime-kilns. Before kindling one of these latter the *fellāhīn* gather enormous piles of this plant—carried on their heads in masses much larger than the bearers—around the kiln mouth.

Thorny hedges around dwellings and fields are very common. The most characteristic plant for the purpose today is the "prickly pear" (*Opuntia ficus Indica*), but this is a comparatively late introduction. Hedges of brambles, oleasters, etc., are common, esp. where there is some water. In the Jordan valley masses of broken branches of the *Zizyphus* and other thorny trees are piled in a circle round tents or cultivated fields or flocks as a protection against man and beast (Prov 15 19; Mic 7 4, etc.).

The Saviour's "crown of thorns" (Mt 27 29) was according to Palestinian tradition constructed from the twisted branches of a species of *Rhamnaceae*, either the *Zizyphus lotus* or the *Z. spina*.

E. W. G. MASTERMAN

**THOUGHT**, *thôt*: The most frequent word in the OT מַחְשָׁבֶת (*maḥšābheth*, from the vb. חָשַׁב, *hāshabh*, "to think") refers to a "device," or a purpose firmly fixed, as in the passage in Isa (55 7-9) where the "thoughts" of God and of man are contrasted (cf Ps 40 5; 92 5; Jer 29 11). In the NT *διαλογισμός*, *dialogismós* (Mt 15 19; 1 Cor 3

20), refers to the inner reasoning or deliberation of one with himself. See **THINK**.

**THOUSAND**, *thou'zand* (אַלְפִי, 'eleph; χίλιοι, *chilioi*). See **NUMBER**.

**THRACIA**, *thrā'shi-a*, **THRACIAN**, *thrā'shan* (Θρακία, *Thrakia*): The name given to the country lying between the rivers Strymon and Danube. Mention is made of a Thracian horseman in 2 Macc 12 35. The cavalry of this fierce people were in demand as mercenaries in all countries. In 46 AD Thrace became the name of a Rom province. Some have sought a connection between Thracia and the *TIRAS* (q.v.) of Gen 10 2, but the identification is conjectural.

**THRASAEUS**, *thrā-sē'us* (A, Swete and Fritzsche, Θρασάιος, *Thrasaios*, V, Θαρσίου, *Tharsiou*, V<sup>a</sup>, Θαρσέου, *Tharséou*; Conjec. Hort, Θαρσεία, *Tharséa*; AV *Thraseas*): The father of APOLLONIUS (q.v.) (2 Macc 3 5). RVm gives "Or Thraseas." The Gr text is probably corrupt. Perhaps the true reading is "Apollonius of Tarsus."

**THREE** (שְׁלֹשׁ, *shālōsh*; τρεῖς, *treis*). See **NUMBER**.

**THREE CHILDREN, SONG OF THE**. See **SONG OF THE THREE CHILDREN**.

**THRESCORE**, *thrē'skōr*. See **NUMBER**.

**THRESHING**, *thresh'ing* (דָּשָׁה, *dūsh*; ἀλοάω, *aloáō*): *Dūsh* means, lit., "to trample out." In Jer 51 33, דָּרַךְ, *dārakh*, is used of threshing. Fitches and cummin were beaten off with a rod. The distinction between beating and threshing is made in Isa 28 27. Gideon, in order to avoid being seen by the Midianites, beat out his wheat in a wine press instead of threshing it on the threshing-floor (Jgs 6 11). For a general description of the threshing operations see **AGRICULTURE**.

**Figurative**: "Thou shalt thresh the mountains," i.e. thou wilt overcome great difficulties (Isa 41 15). Babylon's destruction was foretold poetically in the language of the threshing-floor (Isa 21 10; Jer 51 33; Dnl 2 35); Zion's foes would be gathered as sheaves on the threshing-floor (Mic 4 12, 13; cf 2 K 13 7; Am 1 3; Hab 3 12); threshing into the vintage, i.e. throughout the summer, indicated an extra abundant yield (Lev 26 5).

JAMES A. PATCH

**THRESHING-FLOOR**, *t.-flōr* (גֹּרֵן, *gōren*; ἄλων, *hālōn*; אֵדָר, 'iddar, occurs in Dnl 2 35): The location and method of making threshing-floors have already been described under **AGRICULTURE**. These floors have come into prominence because of the Bib. events which occurred on or near them. Joseph with his kinsmen and Egypt followers halted for seven days at the threshing-floor of Atad to lament the death of Jacob (Gen 50 10). Probably there was a group of floors furnishing a convenient spot for a caravan to stop. Travelers today welcome the sight of a threshing-floor at their halting-place. The hard level spot is much preferable to the surrounding stony fields for their tents.

David built an altar on Ornan's (Araunah's) threshing-floor (2 S 24 18-24; 1 Ch 21 18-27), which later became the site of the Temple (2 Ch 3 1). David probably chose this place for his altar because it was on an elevation and the ground was already level and prepared by rolling. Uzzah died near the threshing-floor of Nacon for touching the ark (2 S 6 6). Ruth reveals herself to Boaz on his threshing-floor (Ruth 3 6-9).

Threshing-floors are in danger of being robbed (1 S 23 1). For this reason someone always sleeps on the floor until the grain is removed (Ruth 3 7). In Syria at the threshing season it is customary for the family to move out to the vicinity of the threshing-floor. A booth is constructed for shade; the mother prepares the meals and takes her turn with the father and children at riding on the sledge.

The instruments of the threshing-floor referred to in 2 S 24 22 were probably: (1) the wooden drag or sledge, *hārūç* or *mōragh*, Arab. *lauh ed-*

bim" (1 S 4 4 RVm; cf 2 S 6 2; 2 K 19 15); Solomon's throne is really Jeh's throne (1 Ch 29 23), and there shall come a time when Jerus shall be called "the throne of Jeh" (Jer 3 17) and the enemies of Jeh shall be judged by him ("I will set my throne in Elam," Jer 49 38). According to Ezk 43 7, the Lord said of the future temple: "This is the place of my throne."

(3) The rule of the promised theocratic king (the Messiah), its everlasting glory and righteousness. He, too, is Jeh's representative, inasmuch as He

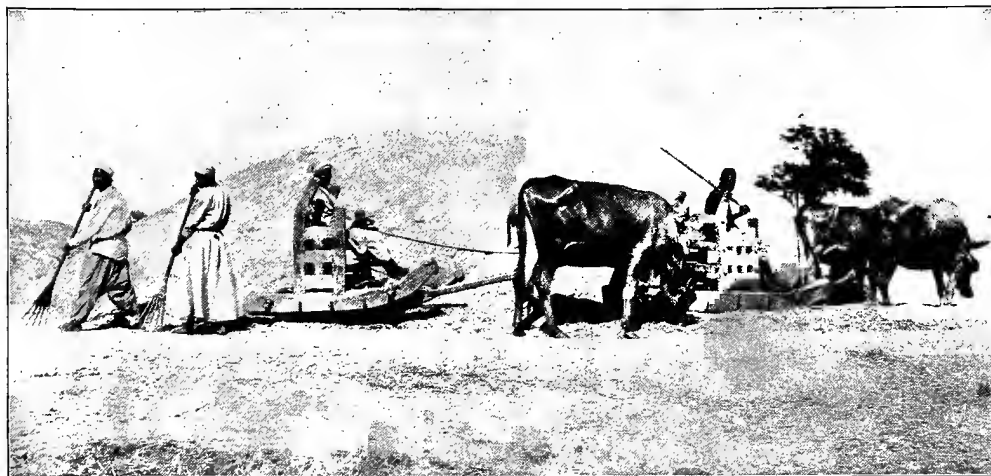

EGYPTIAN THRESHING-FLOOR.

*diras*; (2) the fan (fork), *mizrēh*, Arab. *midrā*, for separating straw from wheat; (3) shovel, *meghrā-phāh*, Arab. *mīrfashat*, for tossing the wheat into the air in winnowing; (4) broom, *ma'ātē*, for sweeping the floor before threshing and for collecting the wheat after winnowing; (5) goad, *malmedh*, Arab. *messās*; (6) the yoke, *ol*, Arab. *ṭauk*; (7) sieve, *k'bhārāh*, Arab. *gharbal*; (8) dung catcher, Arab. *millkat*.  
JAMES A. PATCH

**THRESHOLD**, thresh'old. See HOUSE, II, 1, (7).

**THRONE**, thrōn (כִּסֵּא, *kiṣṣē'*, a "seat" in 2 K 4 10; a "royal seat" in Jon 3 6; θρόνος, *thrónos*): Usually the symbol of kingly power and dignity. Solomon's throne was noted for its splendor and magnificence (1 K 10 18-20; cf 2 Ch 9 17-19). It symbolizes:

(1) The exalted position of earthly kings, rulers, judges, etc, their majesty and power (of kings: Gen 41 40; 1 K 2 19; Job 36 7, etc; denoting governing or judicial power: 2 S 14 9; Neh 3 7; Ps 122 5, etc; often equivalent to kingdom or reign: 1 S 2 8; 1 K 1 37.47, etc; in this connection we note the expressions: "a man on the throne of Israel," 1 K 2 4, etc; "to sit upon a throne," 1 K 1 13.17, etc; Jer 13 13, etc; "to set a person on a throne," 2 K 10 3; "the throne of Israel," 1 K 8 20, etc; "the throne of David," 2 S 3 10, etc; of Solomon, 2 S 7 13, etc; of Joash, 2 Ch 23 20, etc). In Jer 17 12 it is equivalent to "temple" ("A glorious throne . . . is the place of our sanctuary"); it symbolizes the power of the Gentiles being hostile to the people of Jeh (Ps 94 20), and is used metaphorically in Isa 22 23 ("He [i.e. Eliakim] shall be for a throne of glory to his father's house").

(2) The majesty and power of Jeh as the true king of Israel; He "is enthroned above the cheru-

"shall rule upon his throne" (Zec 6 13). Thus the permanence of the throne of David is warranted

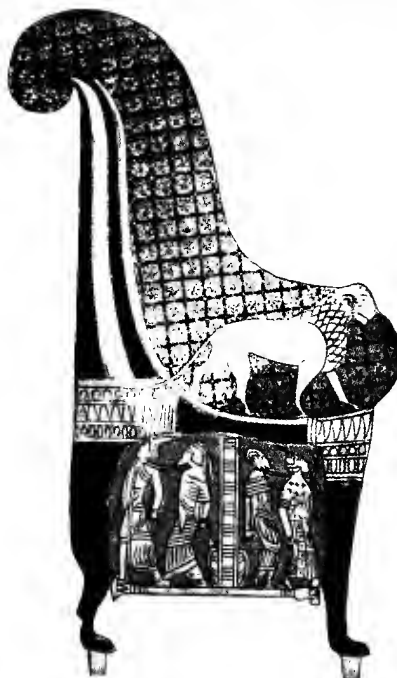

Egyptian Throne.

(Isa 9 7); eternal peace (1 K 2 33), loving-kindness and justice (Isa 16 5) characterize his reign. The NT points to Jesus as this promised king (Lk

1 32; cf Acts 2 30; He 12 2); Christ Himself refers to His future state of glory (Mt 25 31) and guarantees His faithful disciples a similar distinction (Mt 19 28; cf Lk 22 30; Rev 20 4).

(4) The matchless glory, the transcendent power and absolute sovereignty of God (and Christ);

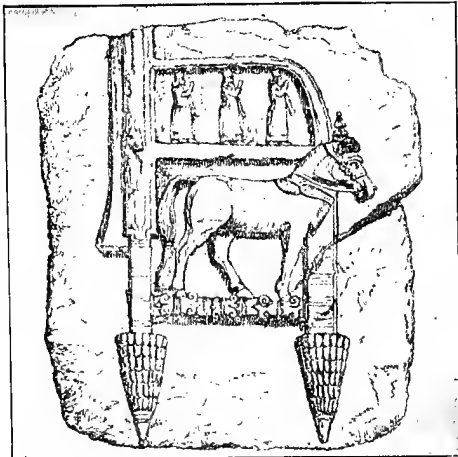

Arm-Chair or Throne (Khorsabad).

Micaiah "saw Jeh sitting on his throne," etc (1 K 22 19; cf 2 Ch 18 18); Isaiah and Ezekiel had similar visions (Isa 6 1; Ezk 1 26); cf also Dnl 7 9 and Rev 4 2 (and often); in trying to depict the incomparable greatness of the King of kings, the Bible tells us that His throne is in heaven (Ps 11 4, etc) and, moreover, that heaven itself is His throne (Isa 66 1; Mt 5 34, etc); His reign is founded on righteousness and justice (Ps 89 14; cf 97 2) and of eternal duration (Ps 45 6; cf He 1 8; Lam 5 19); He acts justly and kindly (Ps 9 4 and 89 14); He defends His glory (Jer 14 21); He manifests His holiness (Ps 47 8) and His grace (He 4 16), and yet His dealings with us are not always fully understood by us (Job 26 9).

(5) Heavenly kingdoms or rulers (angels: Col 1 16). See KING, KINGDOM. WILLIAM BAUR

**THRUM**, thrum: In Isa 38 12 RV reads "He will cut me off from the loom," m "thrum." "Thrum" is a technical term of weavers, denoting the threads of the warp hanging down in a loom, suiting תָּרָוּת, *dallāh*, "that which hangs down" (Cant 7 5, "hair"). A misinterpretation of "hanging down" is responsible for AV's "pining sickness."

**THUMMIM**, thum'im. See URIM AND THUMMIM.

**THUNDER**, thun'dēr (רָעַם, *ra'am* [1 S 2 10; Job 26 14; 39 19; 40 9; Ps 77 18; 81 7; 104 7; Isa 29 6], קוֹל, *kōl*, "a voice" [Ex 9 23; 1 S 7 10; 12 17; Job 28 26; 38 25]): Thunder is the noise resulting from the lightning discharge. It is very common in the winter storms of Syria and Pal and occurs in the extra-season storms. Thunder accompanied the storm of hail in Egypt at the time of the plagues: "The Lord sent thunder and hail" (Ex 9 23).

Lightning and thunder are indications of the power of Jeh and His might. "The thunder of his power who can understand?" (Job 26 14); "The God of glory thundereth" (Ps 29 3). Jeh also confused the Philis with thunder (1 S 7 10), and His foes were "visited of Jeh of hosts with thunder"

(Isa 29 6). Thunder was regarded as the voice of Jeh: "God thundereth with the voice of his excellency" (Job 37 4), and God spoke to Jesus in the thunder (*βροντή, brontē*, Jn 12 29). See also LIGHTNING.

ALFRED H. JOY

**THYATIRA**, thī-a-tī'ra (Θυάτειρα, *Thudēteira*): Thyatira was a wealthy town in the northern part of Lydia of the Rom province of Asia, on the river Lycus. It stood so near to the borders of Mysia, that some of the early writers have regarded it as belonging to that country. Its early history is not well known, for until it was refounded by Seleucus Nicator (301-281 BC) it was a small, insignificant town. It stood on none of the Gr trade routes, but upon the lesser road between Pergamos and Sardis, and derived its wealth from the Lycus valley in which it rapidly became a commercial center, but never a metropolis. The name "Thyatira" means "the castle of Thya." Other names which it has borne are Pelopia and Semiramis. Before the time of Nicator the place was regarded as a holy city, for there stood the temple of the ancient Lydian sun-god, Tyrimnos; about it games were held in his honor. Upon the early coins of Thyatira this Asiatic god is represented as a horseman, bearing a double-headed battle-ax, similar to those represented on the sculptures of the Hittites. A goddess associated with him was Boreatene, a deity of less importance. Another temple at Thyatira was dedicated to Sambethe, and at this shrine was a prophetess, by some supposed to represent the Jezebel of Rev 2 20, who uttered the sayings which this deity would impart to the worshippers.

Thyatira was specially noted for the trade guilds which were probably more completely organized there than in any other ancient city. Every artisan belonged to a guild, and every guild, which was an incorporated organization, possessed property in its own name, made contracts for great constructions, and wielded a wide influence. Powerful among them was the guild of coppersmiths; another was the guild of the dyers, who, it is believed, made use of the madder-root instead of shell-fish for making the purple dyestuffs. A member of this guild seems to have been Lydia of Thyatira, who, according to Acts 16 14, sold her dyes in Philippi. The color obtained by the use of this dye is now called Turkish red. The guilds were closely connected with the Asiatic religion of the place. Pagan feasts, with which immoral practices were associated, were held, and therefore the nature of the guilds was such that they were opposed to Christianity. According to Acts 19 10, Paul may have preached there while he was living at Ephesus, but this is uncertain; yet Christianity reached there at an early time. It was taught by many of the early church that no Christian might belong to one of the guilds, and thus the greatest opposition to Christianity was presented.

Thyatira is now represented by the modern town of *Ak-Hissar* on a branch line of the Manisa-Soma Railroad, and on the old Rom road 9 hours from Sardis. *Ak-Hissar* is Turkish for "white castle," and near the modern town may be seen the ruins of the castle from which the name was derived. The village is of considerable size; most of the houses are of mud, but several of the buildings erected by Caracalla are still standing, yet none of them are perfect. In the higher part of the town are the ruins of one of the pagan temples, and in the walls of the houses are broken columns and sarcophagi and inscribed stones. The population of 20,000 is largely Gr and Armenian, yet a few Jews live among them. Before the town is a large marsh, fever-laden, and esp. unhealthy in the summer time, formed by the Lycus, which the Turks now call

*Geurdeuk Chai.* The chief modern industry is rug-making. E. J. BANKS

**THYINE**, thī'in, **WOOD** (ξύλον θύϊνον, *xúlon thúïnon*): An aromatic wood described as sold in "Babylon" (Rev 18 12, AVm "sweet wood"). It

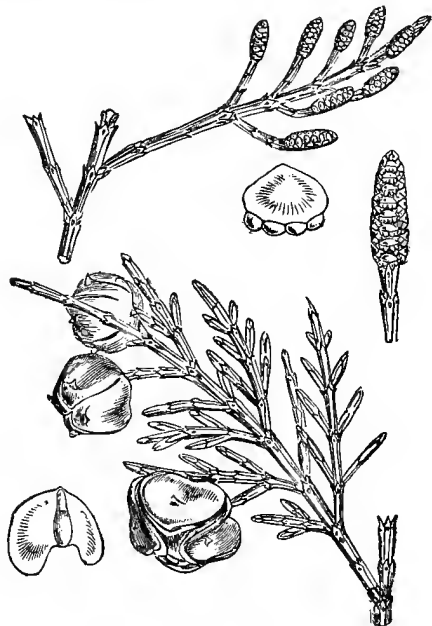

Thyine Wood (*Callitris quadrivalvis*).

is the wood of the thya (*θύια, thúia*) tree, probably identical with *Thuia articulata*, an evergreen tree growing in North Africa, resembling the cypress, which in Rom times was employed for making valuable furniture.

**TIBERIAS**, tī-bē'ri-as (Τιβεριάς, *Tiberiás*, Jn 6 23): About the middle of the western shore of the Sea of Galilee, the mountains fall back from the coast, and leave a roughly crescent-shaped plain, about 2 miles in length. The modern city of Tiberias (*Ṭabarīyeh*) stands at the northern extremity, where the ground begins to rise; and the Hot Baths (*Hammath*) at the south end. On the southern part of this plain Herod Antipas built a city (c 28 AD), calling it "Tiberias" in honor of the emperor who had befriended him. In clearing the ground and digging foundations certain tombs were disturbed (*Ant*, XVIII, ii, 3). It may have been the graveyard of old Hammath. The palace, the famous "Golden House," was built on the top of a rocky hill which rises on the W. to a height of some 500 ft. The ruin is known today as *Qasr*

*bint el-Melek*, "Palace of the King's Daughter." The strong walls of the city can be traced in almost their entire length on the landward side. Parts are also to be seen along the shore, with towers at intervals which guarded against attack by sea. The ruins cover a considerable area. There is nothing above ground older than Herod's city. Only excavation can show whether or not the Talm is right in saying that Tiberias was built on the site of Rakkath and Chinnereth (Neubauer, *Géog. du Talm*, 208). The Jews were shy of settling in a city built over an old cemetery; and Herod had trouble in finding occupants for it. A strange company it was that he ultimately gathered of the "poorer people," foreigners, and others "not quite freemen"; and these were drawn by the prospect of good houses and land which he freely promised them. With its stadium, its palace "with figures of living things," and its senate, it may be properly described as a Gr city, although it also contained a *proseuchê*, or place of prayer, for the Jews (*BJ*, II, xxi, 6; *Vita*, XII, 54, etc). This accounts for it figuring so little in the Gospels. In his anxiety to win the favor of the Jews, Herod built for them "the finest synagogue in Galilee"; but many years were to elapse before it should become a really Jewish city.

Superseding Sepphoris, Tiberias was the capital of Galilee under Agrippa I and the Rom procurators. It surrendered to Vespasian, and was given by Nero to Agrippa II, Sepphoris again becoming the capital. During the Jewish war its inhabitants were mainly Jewish, somewhat turbulent and difficult to manage. In 100 AD, at Agrippa's death, the Romans assumed direct control. After the fall of Jerus, the Sanhedrin retreated to Galilee, first to Sepphoris, and then to Tiberias. Here, some time before 220 AD, under supervision of the famous Rabbi Jehuda ha-Nāsī, "Judah the Prince," or, as he is also called, *ha-ḳādōsh*, "the Holy," the



Tiberias.

civil and ritual laws, decrees, customs, etc, held to be of binding obligation, handed down by tradition, but not having Scriptural authority, were codified and written down, under the title of "Mishna." Here also later was compiled the Jerus Talm

(*Yerūshalmī*), as distinguished from that compiled in Babylon (*Babli*). The city thus became a great center of Jewish learning. Maimonides' tomb is shown near the town, and that of Akiba on the slope of the mountain, where it is said 24,000 of his disciples are buried with him.

In Christian times Tiberias was the seat of a bishop. It fell to the Moslems in 637. It changed hands several times as between the Crusaders and the Saracens. It was finally taken by the Moslems in 1247.

The inclosing walls of the modern city, and the castle, now swiftly going to ruin, were built by Tancred and repaired by Daher el-'Omar in 1730. There are over 5,000 inhabitants, mostly Jews, in whose hands mainly is the trade of the place. The fishing in the lake, in which some 20 boats are occupied, is carried on by Moslems and Christians. Tiberias is the chief inhabited place on the lake, to which as in ancient days it gives its name, *Bahr Tabariyeh*, "Sea of Tiberias" (Jn 6 1; 21 1). It is the market town for a wide district. The opening of the Haifa-Damascus Railway has quickened the pulse of life considerably. A steamer and motor boat ply between the town and the station at *Semach*, bringing the place into easy touch with the outside world. The water of the lake is largely used for all purposes, although there are cisterns for rain water under some of the houses.

After a residence of over five years in the city, the present writer can say that it does not deserve the evil reputation which casual travelers have given it. In matters of cleanliness and health it stands comparison very well with other oriental towns. Sometimes, in east wind, it is very hot, the thermometer registering over 114° Fahr. in the shade. The worst time is just at the beginning of the rainy season, when the impurities that have gathered in the drought of summer are washed into the sea, contaminating the water.

The United Free Church of Scotland has here a well-equipped mission to the Jews. W. EWING

**TIBERIAS, SEA OF.** See GALILEE, SEA OF.

**TIBERIUS**, tī-bē'ri-us (Τιβέριος, *Tibérios*): The 2d Rom emperor; full name Tiberius Claudius Nero, and official name as emperor

**1. Name and Parentage** Tiberius Caesar Augustus; born November 16, 42 BC. His father—of the same name—had been an officer under Julius Caesar and had later joined Antony against Octavian (Augustus). His mother was Livia, who became the 3d wife of Augustus; thus T. was a stepson of Augustus.

Much of his early life was spent in successful campaigning. Although the ablest of the possible heirs of Augustus, T. was subjected to many an indignity, Augustus accepting him as his successor only when every other hope failed. When Julia, daughter of Augustus, became a widow for the second time (12 BC), T. was obliged to marry her (11 BC) in order to become protector of the future emperors. For this purpose he was compelled to divorce his wife, Vipsania Agrippina, who had borne him a son, Drusus. Julia brought T. nothing but shame, and for her immorality was banished by her father (2 BC). T. was consul in 12 BC, and received the proconsular authority, 9 BC. He carried on successful wars in Pannonia, Dalmatia, Armenia and Germany. He retired in disgust to voluntary exile at Rhodes where he spent several years in study. In 2 AD, he returned to Rome, and lived there in retirement, 2-4 AD. On June 27, 4 AD, T. and Agrippa Postumus were adopted by Augustus. From this date on T.

came more and more into prominence, receiving the tribunician power for 10 years.

In 13 AD (or according to Mommsen 11 AD) T. was by a special law raised to the co-regency.

Augustus died August 19, 14 AD, and **3. Reign** T. succeeded. A mutiny in the Rhine legions was suppressed by Germanicus.

The principal events of his reign (see also below) were the campaigns of Germanicus and Drusus, the withdrawal of the Romans to the Rhine, the settlement of the Armenian question, the rise and fall of Sejanus, the submission of Parthia. In 26 AD, T. retired to Capreae, where rumor attributed to him every excess of debauchery. On March 16, 37 AD, T. died at Misenum and was succeeded by Caius.

On the whole, T. followed the conservative policy of Augustus and maintained the "diarchy." But

he approached nearer to monarchy by receiving supreme power for an *indefinite* period. He went beyond Augustus in practically excluding the people from government by transferring the right of election from the *comitia* of the people to the senate, leaving to the people the right merely to *acclaim* the nominees of the senate, and further by imposing laws upon the people without their counsel or discussion. He established a permanent praetorian camp at Rome—a fact of great importance in later Rom history. The administration of T. was that of a wise, intelligent statesman with a strong sense of duty. The civil service was improved, and officers were kept longer at their posts to secure efficiency. Taxes were light on account of his economy. Public security increased. He paid attention to the administration of justice and humane laws were placed on the statute-book.

Though T. was unpopular, he left the empire in a state of prosperity and peace. Of his character the most opposite views are held.

**5. Character** His fame has suffered esp. from his suspecting nature, which extended the law of *majestas* to offences against his person and encouraged *delation*, which made the latter part of his reign one of terror. The tyranny of Sejanus, too, has been laid upon his shoulders, and he has been accused of the wildest excesses in his retreat at Capreae—a charge which seems to be refuted by the fact that no interruption to his wise administration took place. His character has been blackened most by Tacitus and Suetonius. But on nearer criticism T.'s character will appear in better light. No doubt, toward the close of his reign he degenerated, but his cruelties affected only the upper classes. He was called a tyrant and was refused deification after death, and Augustus was said to have prophesied "Alas for the Rom people who shall be ground under such slow jaws." T. was stern and taciturn, critical with himself and, soured by his own disappointments, was suspicious of others. Pliny the Elder calls him "the gloomiest of men." Much of his unpopularity was due to his inscrutability, to the fact that people could not understand him or penetrate into the mystery of his motives. He rarely took counsel with anyone. His life was frugal and modest—a rebuke to the contemporary dissipation. He felt contempt for the inanities of court life, and was supremely indifferent to public opinion, but actuated by a strong sense of duty.

The reign of T. is memorable as that in which fell Our Lord's public ministry, death and resurrection.

It also witnessed the preaching of **6. Tiberius** John the Baptist (Lk 3 1), the conversion of Paul and perhaps his first preaching, the martyrdom of Stephen and the first Christian persecution (by the Jews). Tiberius is mentioned by name only once in the NT (Lk 3 1): "the 15th year of the reign [ἡγεμονία,

*hēgemonía*] of Tiberius." The question is, From what date is this to be reckoned—the date of T.'s co-regency, 13 (or 11) AD, or from his accession, 14 AD? He is the "Caesar" mentioned in the Gospels in connection with Jesus' public ministry (Mk 12 14 and ||'; Jn 19 12.15). Herod Antipas built Tiberias in honor of T. (Jos, *Ant*, XVIII, ii-iii). It is unlikely that T. ever heard anything about Christianity; it had not risen as yet into prominence. Early Christian writers wished to represent T., if not friendly to the new faith, at least as condemning the action of Pilate. According to Justin (*Apol.*, i.35), Tertullian (*Apol.*, 21) and Eusebius (*HE*, II, ii), Pilate reported to T. about the trial and crucifixion of Jesus—and some such report is not improbable. According to one apocryphal tradition, T. actually summoned Pilate to Rome to answer for crucifying Jesus. It is true that Pilate was sent to Rome by the governor of Syria to answer to a charge of unjustifiable cruelty, but T. died before Pilate reached Rome.

Under T., Pal was governed by Rom procurators. Toward the Jews in Italy, T. showed some intolerance. In 19 AD all the Jews were

**7. Tiberius** expelled from Rome according to Jos and the (Ant, XVIII, iii, 5), from Italy according to Tacitus (*Ann.* ii.85), and 4,000 Jews Jewish freedmen were deported to Sardinia to reduce bands of brigands. Philo attributes this severity to Sejanus, and says that after Sejanus' fall T., recognizing that the Jews had been persecuted without cause, gave orders that officials should not annoy them or disturb their rites. They were therefore probably allowed to return to Rome (see Schürer, III, 60 f, 4th ed).

LITERATURE.—(a) Ancient lit., as modern, is divided on its estimate of T.: Tac. *Annals* i-vi; Dio Cassius *Rom. Hist.* xvi-xlviii, and Suetonius *Tib.* painting him in the darkest colors, while Velleius Paterculus II gives the other side. (b) Of modern lit. it is enough to cite on opposite sides: J. C. Tarver, *Tiberius the Tyrant*, 1902; Ihne, *Zur Ehrenrettung des K. Tib.*, 1892, and the moderate estimate of Merivale, *Romans under the Empire*.

S. ANGUS

**TIBHATH**, tib'hath (תִּבְחַת, *tibhath*; Μεταβηχάς, *Metabēchás*, A, Ματεβέθ, *Malebēth*; Vulg *Thebath*; Pesh *Tēbhah*): A city of Hadadezer, king of Zobah, from which David took much of the brass used later by Solomon in the construction of the temple-furnishings (1 Ch 18 8). In 2 S 8 8 we must for the *betah* of the MT read with the Syr *Tēbhah*. It may be the same as the *Tubihī* of the Am Tab; the *Dibhu* of the Karnak lists; and the *Tubihī* mentioned with Kadesh on the Orontes in the "Travels of an Egyptian" in the reign of Rameses II. The site is unknown, but it must have been on the eastern slopes of Anti-Lebanon, between which and the Euphrates we must locate Hadadezer's kingdom of Zobah. "Tebah" occurs also as an Aram. personal or tribal name in Gen 22 24. W. M. CHRISTIE

**TIBNI**, tib'nī (תִּבְנִי, *tibhnī*; B, Θαμνι, *Thamnet*, A, Θαμνι, *Thamni*, Luc., Θαβεννι, *Thabennet*): A rival of Omri for the throne of Israel after the death of Zimri (1 K 16 21 f). This is the only reference to Tibni that has come down to us; a comparison of this passage with the account of Zimri's death (esp. ver 15) shows that the length of the struggle was four years.

**TIDAL**, ti'dal (תִּדְגַל, *tidh'al*; Θαλαγά, *Thalga*, Θαλαγά, *Thalga*, E, Θαργά, *Thargal*): Tidal is mentioned in Gen 14 1.9 in the account of the expedition of Chedorlaomer

**1. The Name and Its Forms** of Elam, with his allies, Amraphel of Shinar (Babylonia), Arioch of Ellasar, and Tidal, who is called "king of nations" (AV) (*gōyim*, Tg *ammīn*). Whether the

last-named took part in this expedition as one of Chedorlaomer's vassals or not is unknown. The Gr form possibly points to an earlier pronunciation *Tadgal*.

The only name in the cuneiform inscriptions resembling Tidal is *Tudhula*, or, as it was probably later pronounced, *Tudhul*. This, from **2. Its Baby-** its form, might be Sumerian, meaning **lonian** "evil progeny," or the like. In addition **Equivalent** tion to the improbability of a name with such a signification, however, his title "king of *gōyim*," or "nations," in Gen 14 1, presupposes a ruler of another race.

The inscription in which the name *Tudhula* occurs is one of three of late date (4th to 3d cent.

**3. The** BC), all referring, apparently, to the **Babylonian** same historical period. The text in **Tudhula** question (*Sp.* iii.2) is of unbaked clay, **and His** and is broken and defaced. After **Time** referring to a ruler who did not maintain the temples, Durmaḥ-īlāni son of Eri-Aku (Arioch) is referred to, apparently as one who ravaged the country, and "waters [came] over Babylon and Ē-sagila," its great temple. The words which follow suggest that Durmaḥ-īlāni was slain by his son, after which a new invader appeared, who would seem to have been *Tudhula*, son of Gazzā(ni?). He likewise ravaged the land, and floods again invaded Babylon and Ē-sagila. To all appearance he met with the fate which overtook Durmaḥ-īlāni—death at the hands of his son, who "smote his head." Then came the Elamite, apparently Chedorlaomer, who was likewise slain. This inscription, therefore, gave historical quotations of the fate which overtook those who were regarded as enemies of the gods.

Though we have here the long-sought name of Tidal, it may legitimately be doubted whether this

**4. Doubts** personage was the ruler of that name **as to His** mentioned in Gen 14. The "nations" **Identity** as to His (*gōyim*) which he ruled are regarded by Sayce as having been wandering hordes (*umman manda*), probably Medes.

On the other hand, the occurrence of the name *Dudhalla*, son of Ḫattušil (Khetasir), contemporary of Rameses II, in the inscriptions found at Ḫattu, the capital of the Hittites, suggests that that extensive confederation may have been the "nations" referred to. In other words, Tidal or *Tudhula* (for *Dudhalla*) was an earlier ruler bearing the same name as Ḫattušil's son. If he be, as is possible, the same

**5. Probably** personage as is mentioned in Gen 14, **a Hittite** he must have fought against Arioch's son, conquered his domains and been killed, in his turn, by either the Bib.

Chedorlaomer or another Elamite ruler bearing the same or a similar name. See AMRAPHEL; ARIOCH; CHEDORLAOMER; ERI-AKU; NATIONS.

T. G. PINCHES

**TIDINGS**, ti'dingz, **GLAD**. See **GLAD** TIDINGS.

**TIGLATH-PILESER**, tig-lath-pi-lē'zēr, -pī-lē'zēr (תִּגְלַת פִּלְעֶזֶר, *tighlath pil' eser*, as the name is read in 2 K, תִּלְגַּת פִּלְעֶזֶר, *till'ghath pilneser*, in 2 Ch; LXX Ἀγαθφελλασάρ, *Algathphellasar*; Assy, *Tukulti-abal-i-šarra*): King of Assyria in the days of Menahem, Pekahiah, and Pekah, kings of Israel, and of Uzziah, Jotham and Ahaz, kings of Judah. The king of Assyria, whom the historian of 2 K knows as exacting tribute from Menahem, is Pul (2 K 15 19 f). In the days of Pekah who had usurped the throne of Menahem's son and successor, Pekahiah, the king of Assyria is known as Tiglath-pileser, who invaded Naphtali and carried the inhabitants captive to Assyria (2 K 15 29). This



invasion is described by the Chronicler (1 Ch 5 25 f) rather differently, to the effect that "the God of Israel stirred up the spirit of Pul king of Assyria, and the spirit of Tiglath-pileser king of Assyria, and he carried them away, even the Reubenites, and the Gadites, and the half-tribe of Manasseh, and brought them unto Halah, and Habor, and Hara, and to the river of Gozan, unto this day." Still later we find Pekah forming a coalition with Rezin, king of Damascus, into which they tried to force Ahaz, even going the length of besieging him in Jerus (2 K 16 5). The siege was unsuccessful. Ahaz called in the aid of Tiglath-pileser, sacrificing his independence to get rid of the invaders (2 K 16 7,8). He offered the Assyrian the silver and gold that were found in the house of the Lord and in the royal treasury; and Tiglath-pileser, in return, invaded the territories of Damascus and Israel in the rear, compelling the allied forces to withdraw from Judah, while he captured Damascus, and carried the people away to Kir and slew Rezin (2 K 16 9). It was on the occasion of his visit to Damascus to do homage to his suzerain Tiglath-pileser, that Ahaz fancied the idolatrous altar, a pattern of which he sent to Urijah, the priest, that he might erect an altar to take the place of the brazen altar which was before the Lord in the temple at Jerus. It is a significant comment which is made by the Chronicler (2 Ch 28 21) upon the abject submission of Ahaz to the Assyrian king: "It helped him not."



Tiglath-pileser I (from Rock Tablet near Korkhar).

From the inscriptions we learn particulars which afford striking corroboration of the Bib. narrative and clear up some of the difficulties involved. It is now practically certain that Pul, who is mentioned as taking tribute from Menahem, is identical with Tiglath-pileser (Schrader, *COT*, I, 230, 231). In all probability Pul, or Pulu, was a usurper, who as king of Assyria assumed the name of one of his predecessors, Tiglath-pileser I, and reigned as Tiglath-pileser III. This king of Assyria, who reigned, as we learn from his annals, from 745 BC to 727 BC, was one of the greatest of Assyr monarchs. See ASSYRIA. From the fact that no fewer than five Heb kings are mentioned in his annals, the greatest interest attaches to his history as it has come down to us. These kings are Uzziah or Azariah, and Jehoahaz, that is Ahaz, of Judah; and Menahem, Pekah and Hoshea of Israel. Along with them are mentioned their contemporaries Rezin of Damascus, Hiram of Tyre, and two queens of Arabia, otherwise unknown, Zabibi and Samsi. When he died in 727 BC, he was succeeded by Shalmaneser IV, who had occasion to suspect the loyalty of his vassal Hoshea, king of Israel, and besieged him in Samaria.

LITERATURE.—Schrader, *COT*, I, 229-57; McCurdy, *HPM*, §§ 279-341.

T. NICOL

**TIGRIS**, tî'gris (Τίγρις, *Tigris*, the Gr equivalent of the Heb תִּיגְרִיִּס, *hiddekel*): One of the rivers of Eden going "eastward to Assyria" (Gen 2 14 m), called the Great River (Dnl 10 4), elsewhere mentioned in the apocryphal books, as in Tob 6 1; Jth 1 6; Eccles 24 25, called Diglath in Jos, and Diglit in Pliny, now called in Mesopotamia *Dijleh*, generally supposed to be a Sem corruption of Tigra, meaning originally an arrow, which from its rapidity of motion is symbolized. The Tigris rises in the mountains of Armenia, lat. 38° 10', long. 39° 20', only a few miles from the main branch of the

Euphrates. After pursuing a tortuous south-easterly course for 150 miles, it is joined by the east branch at Osman Kieui, some distance below Diarbekr. Here the stream is 450 ft. wide and 3 or 4 ft. deep. Passing through numerous mountain gorges for another 150 miles, it emerges into the region of low hills about Nineveh, and a little below into the great alluvial plain of Mesopotamia. Thence in its course to Bagdad it is joined by the Great Zab, the Lesser Zab, the Adhem, and the Diyaleh rivers, bringing a large amount of water from the Zagros Mountains. At Bagdad the overflows from the Euphrates in high water often increase the inundations. The flood season begins early in the month of March, reaching its climax about May 1, declining to its natural level by midsummer. In October and November, the volume of water increases considerably, but not so much as to overflow its banks. Below Bagdad, throughout the region of Babylonia proper, the Tigris joins with the Euphrates in furnishing the water for irrigation so successfully used in ancient times. English engineers are at present with great promise of success aiming to restore the irrigating systems of the region and the prosperity of ancient times. The total length of the river is 1,146 miles. It now joins the Euphrates about 40 miles N.W. of the Pers Gulf, the two streams there forming the *Shat el Arab*, but in early historical times they entered the Pers Gulf by separate mouths, the Gulf then extending a considerable distance above the present junction of the rivers, the sediment of the streams having silted up the head of the Gulf to that distance. See also EDEN.

GEORGE FREDERICK WRIGHT

**TIKVAH**, tik'va, **TIKVATH**, tik'vath (תִּיקְוָה, *tîk'wâh*, "hope"):

(1) The father-in-law of Huldah the prophetess (2 K 22 14) (B, Θεκκουά, *Thekkouai*, A, Θεκκούε, *Thekkoué*, Luc., Θεκουέ, *Thekoué*), called in 2 Ch 34 22 "Tokhath" (כָּרֵר תִּיקְוָה, *K'athib* תִּיקְוָה, B, Καθουάλ, *Kathouál*, A, Θακουάθ, *Thakouáth*, Luc., Θεκωέ, *Thekôé*). The reading of 2 K is to be preferred.

(2) The father of Jahzeiah (Ezr 10 15) (B, Ἑλκειά, *Helkeiá*, A, Θεκουέ, *Thekoué*, called "Theocanus," RV "Thocanus," in 1 Esd 9 14).

**TILE**, til, **TILING**, til'ing (לִבְנֵי, *lîbhênâh*, "brick," Ezk 4 1; κέραμος, *kéramos*, "potter's clay," "a tile," Lk 5 19). See ΕΞΑΚΙΣΤΕΛ, II, 1, (2); HOUSE, II, 1, (10).

**TILGATH-PILNESER**, til'gath-pil-né'sér, -sér. See TIGLATH-PILESER.

**TILLAGE**, til'áj. See AGRICULTURE.

**TILON**, tî'lon (תִּילּוֹן, *tîlôn*; K'athib תִּילּוֹן, *K'arê תִּילּוֹן*; B, Ἰών, *Inôn*, A, Θιλών, *Thilôn*, Luc., Θωλεμ, *Thôleim*): A son of Shimon (1 Ch 4 20).

**TIMAEUS**, tí-mé'us (Τίμαϊος, *Tímaïos* [Mk 10 46]; EV "Timaeus"). See BARTIMAEUS.

**TIMBREL**, tim'brel. See MUSIC, III, 3, (1).

**TIME**, tím: The basis of the Heb measurement of time was the day and the lunar month, as with the Semites generally. The division of the day into hours was late, probably not common until after the exile, although the sun-dial of Ahaz (2 K 20 9; Isa 38 8) would seem to indicate some division of the day into periods of some sort, as we know the night was divided. The word used for

"hour" is Aram. שְׂעֵי, *shē'ā'* (שְׂעֵי, *sha'tā'*), and does not occur in the OT until the Book of Dnl (4 33; 5 5), and even there it stands for an indefinite period for which "time" would answer as well.

The term "day" (יּוֹם, *yōm*) was in use from the earliest times, as is indicated in the story of the Creation (Gen 1). It there doubt-  
**1. The Day** less denotes an indefinite period, but is marked off by "evening and morning" in accordance with what we know was the method of reckoning the day of 24 hours, i.e. from sunset to sunset.

The night was divided, during præilic times, into three divisions called watches (שְׁמֹרֶת, *'ashmūrāh*, שְׁמֹרֶת, *'ashmōreth*), making periods  
**2. Night** of varying length, as the night was longer or shorter (Jgs 7 19). This division is referred to in various passages of the OT, but nowhere with indication of definite limits (see Ps 90 4; 119 148; Jer 51 12; Hab 2 1).

In the NT we find the Rom division of the night into four watches (φυλακή, *phulaké*) in use (Mt 14 25; Mk 6 48), but it is probable that the former division still persisted. The use of the term "day" for the period from sunrise to sunset, or for day as distinguished from night, was common, as at present (Josh 10 13; Ps 19 2; Prov 4 18; Isa 27 3; Jn 9 4, etc.). But the use of the word in the indefinite sense, as in the expressions: "day of the Lord," "in that day," "the day of judgment," etc., is far more frequent (see DAY). Other more or less indefinite periods of the day and night are: dawn, dawning of the day, morning, evening, noonday, midnight, cock-crowing or crowing of the cock, break of day, etc.

The weekly division of time, or the seven-day period, was in use very early and must have been known to the Hebrews before the

**3. Week** Mosaic Law, since it was in use in Babylonia before the days of Abraham and is indicated in the story of the Creation. The Heb שַׁבָּע, *shābhā'*, used in the OT for "week," is derived from שֶׁבַע, *shebha'*, the word for "seven." As the seventh day was a day of rest, or Sabbath (Heb שַׁבָּת, *shabbāth*), this word came to be used for "week," as appears in the NT (σαββατικός, *sabbatón, -tá*), indicating the period from Sabbath to Sabbath (Mt 28 1). The same usage is implied in the OT (Lev 23 15; 25 8). The days of the week were indicated by the numerals, *first, second*, etc, save the *seventh*, which was the Sabbath. In NT times Friday was called the day of preparation (παράσκευή, *paraskēuē*) for the Sabbath (Lk 23 54).

The monthly division of time was determined, of course, by the phases of the moon, the appearance of the new moon being the beginning

**4. Month** of the month, חֹדֶשׁ, *hōdesh*. Another term for month was *yerah* (יָרַח), meaning "moon," which was older and derived from the Phoen usage, but which persisted to late times, since it is found in the Aram. inscriptions of the 3d cent. AD in Syria. The names of the months were Bab and of late origin among the Hebrews, probably coming into use during and after the Captivity. But they had other names, of earlier use, derived from the Phoenicians, four of which have survived in "Abib," "Ziv," "Ethanim" and "Bul" (see CALENDAR).

The Heb year (שָׁנָה, *shānāh*) was composed of 12 or 13 months, the latter being the year when an intercalary month was added to make

**5. Year** the lunar correspond with the solar year. As the difference between the two was from ten to eleven days, this required the

addition of a month once in about three years, or seven in nineteen years. This month was added at the vernal equinox and was called after the month next preceding, *u-ādhar*, or the "second Adar." We do not know when this arrangement was first adopted, but it was current after the Captivity. There were two years in use, the civil and the ritual, or sacred year. The former began in the autumn, as would appear from Ex 23 16; 34 22, where it is stated that the "feast of ingathering" should be at the end of the year, and the Sabbatic year began in the 7th month of the calendar or sacred year, which would correspond to September-October (Lev 25 9). Jos says (*Ant*, I, iii, 3) that Moses designated Nisan (March-April) as the 1st month of the festivals, i.e. of the sacred year, but preserved the original order of the months for ordinary affairs, evidently referring to the civil year. This usage corresponds to that of the Turkish empire, where the sacred year is lunar and begins at different seasons, but the financial and political year begins in March O.S. The beginning of the year was called ראש השנה, *rō'sh ha-shānāh*, and was determined by the priests, as was the beginning of the month. Originally this was done by observation of the moon, but, later, calculation was employed in connection with it, until finally a system based on accurate calculation was adopted, which was not until the 4th cent. AD. New-Year was regarded as a festival. See ASTRONOMY, I, 5; YEAR.

The return of the seasons was designated by summer and winter, or seed-time and harvest; for they were practically the same. There

**6. Seasons** is, in Pal, a wet season, extending from October to March or April, and a dry season comprising the remainder of the year. The first is the winter (חֹרֶף, *hōreph*), and this is the seed-time (זֵרָה, *zera'*), esp. the first part of it called *yōreh* (יֹרֵה), or the time of the early rain; the second is the summer (קַיִץ, *kayit*, "fruit-harvest," or קָצִיר, *kāṣir*, "harvest").

Seed-time begins as soon as the early rains have fallen in sufficient quantity to moisten the earth for plowing, and the harvest begins in some parts, as in the lower Jordan region, near the Dead Sea, about April, but on the high lands a month or two later. The fruit harvest comes in summer proper and continues until the rainy season. "The time when kings go out to war" (2 S 11 1; 1 K 20 22) probably refers to the end of the rainy season in Nisan.

We have no mention in the OT of any era for time reckoning, and we do not find any such usage until the time of the Maccabees. There are occasional references to certain events which

**7. No Era** might have served for eras had they been generally adopted. Such was the Exodus in the account of the building of the temple (1 K 6 1) and the Captivity (Ezk 33 21; 40 1) and the Earthquake (Am 1 1). Dates were usually fixed by the regnal years of the kings, and of the Pers kings after the Captivity. When Simon the Maccabee became independent of the Seleucid kings in 143-142 or 139-138 BC, he seems to have established an era of his own. If we may attribute to him a series of coins dated by the years "of the independence of Israel" (see COINS; MONEY; also 1 Mac 13 41 and 15 6.10). The Jews doubtless were familiar with the Seleucid era, which began in 312 BC, and with some of the local eras of the Phoen cities, but we have no evidence that they made use of them. The era of the Creation was not adopted by them until after the time of Christ. This was fixed at 3,830 years before the destruction of the later temple, or 3760 BC. See ERA.

H. PORTER

**TIME, LAST.** See LAST TIME.

**TIME, TIMES AND A HALF** (Dnl 12 7; cf 7 25; Rev 12 14): A luni-solar cycle. See ASTRONOMY, I, 5.

**TIMES, OBSERVER OF.** See DIVINATION; MAGIC.

**TIMNA**, tim'na (תִּמְנָה, *timna'*; Θαμνά, *Thamna'*): A concubine of Eliphaz, Esau's son, and the mother of Amalek (Gen 36 12). But in Gen 36 22 and 1 Ch 1 39 Timna is the sister of Lotan, and in Gen 36 40 and 1 Ch 1 51 a chief or clan of Edom (see TIMNAH, [3]). These variations are to be expected when the origin of genealogies is recalled. (In Gen EV reads, contrary to rule, "Timnah.") Gunkel's theory is that Gen 36 12a is a later insertion in P.

**TIMNAH**, tim'na (תִּמְנָה, *timnāh*, תִּמְנָה, *timnāthāh* [Josh 19 43; Jgs 14 1.2.5], "allotted portion"; B, Θαμνάθα, *Thamnātha*, also several Gr variations; AV has Timnath in Gen 38 12.13.14; Jgs 14 1.2.5; and Thimnathah in Josh 19 43):

(1) A town in the southern part of the hill country of Judah (Josh 15 57). Tibna proposed by Conder, a ruin 8 miles W. of Bethlehem, seems too far N. (PEF, III, 53, Sh XVII). It is possible this may be the "Timnah" of Gen 38 12.13.14.

(2) A town on the northern border of Judah (Josh 15 10), lying between Beth-shemesh and Ekron. It is probably the same Timnah as Judah visited (Gen 38 12-14), and certainly the scene of Samson's adventures (Jgs 14 1 f); his "father-in-law" is called a "Timnite" (Jgs 15 6). At this time the place is clearly Philistine (Jgs 14 1), though in Josh 19 43 it is reckoned to Dan. Being on the frontier, it probably changed hands several times. In 2 Ch 28 18 it was captured from the Philis by Ahaz, and we learn from Assy evidence (Prison Inscription) that Sennacherib captured a Tamna after the battle of Alteka before he besieged Ekron (Schrader, *Die Keilinschriften und das AT*, 170). The site is undoubted. It is now a deserted ruin called *Tibneh* on the southern slopes of the *Wādī es Surār* (Valley of Sorek), about 2 miles W. of Beth-shemesh. There is a spring, and there are evident signs of antiquity (PEF, II, 417, 441, Sh XVI).

(3) There was probably a Timna in Edom (Gen 36 12.22.40; 1 Ch 1 39.51). Eusebius and Jerome (*Onom*) recognized a Thamna in Edom at their time.

(4) The "Thamnatha" of 1 Macc 9 50 (AV) is probably another Timnah, and identical with the Thamna of Jos (*BJ*, III, iii, 5; IV, viii, 1). This is probably the *Tibneh*, 10 miles N.W. of Bethel, an extensive ruin. E. W. G. MASTERMAN

**TIMNATH**, tim'nath. See TIMNAH.

**TIMNATH-HERES**, tim-nath-hē'rēz, t-hē'rez (סֵרַח תִּמְנָת הָרֵז, *timnath heres*, "portion of the sun"; B, Θαμναθῆρες, *Thamnathāres*, A, Θαμναθῆρ' ἔως, *Thamnathār; hēōs*): This is the form of the name given to Joshua's property and place of burial in Jgs 2 9. The name in Josh 19 50; 24 30 is Timnath-serah. "Serah" simply reverses the order of the letters in "Heres." Scholars are divided in opinion as to which form is correct. It is possible that the change from Heres to Serah may have been deliberate, in order to avoid a form which might savor of idolatry—sun-worship. The Jews and Samaritans hold that Heres is the original form.

W. EWING

**TIMNATH-SERAH**, tim-nath-sē'ra (סֵרַח תִּמְנָת, *timnath serah*; B, Θαμναθῆρες, *Thamarchāres*, A, Θαμναθῆρα, *Thamathsarā*): This place, assigned as an inheritance to Joshua, is described as being in Mt. Ephraim, on the north side of the mountain of Gaash (Josh 19 50; 24 30). Here, when his work was done, the great leader was laid to rest. The

mountain of Gaash unfortunately cannot be identified. Jos says that Joshua was buried at Thamna, a city of Ephraim (*Ant*, V, i, 29), which probably corresponds to Thamna, the head of a Jewish toparchy (*BJ*, III, iii, 5). Vespasian marched from Thamnatha to Lydda, which apparently was near (IV, viii, 1). The place was taken and reduced to slavery by Cassius (*Ant*, XIV, xi, 2). It was put in charge of John the Essene at the beginning of the Jewish war (*BJ*, II, xx, 4). *Onom* (s.v. "Thamna" and "Thamnathsara") identifies it with "Timnath" of Gen 38 12 AV, placing it in the mountain in the tribe of Dan (or Judah), on the way from Diospolis (Lydda) to Jerus. The tomb of Joshua was still shown there. This points to *Tibneh*, in the uplands 12 miles N.E. of Lydda. S. of the village, in the face of a rock, are a series of rock-hewn tombs, the largest of which, containing 14 loculi, and a small chamber behind with one loculus, may be that associated with Joshua by *Onom*. A giant oak grows hard by, perhaps the greatest tree in Pal. *Keḫr Ishū'a*, "village of Joshua," lies about 3 miles to the E. This identification is now generally accepted.

The Sam tradition points to the tomb of Joshua at *Keḫr Hāris*, 9 miles S. of *Nāblus*. Outside the village to the E. are two shrines. One is called *Neby Kīḫl*, the other *Neby Kalā'a*. The former, "prophet of division," or "of the portion," might apply to Joshua; the latter is identified with Caleb. This identification assumes that the first element of the name has fallen out, the second only surviving. W. EWING

**TIMNITE**, tim'nit (תִּמְנִי, *timnī*; Θαμναθαίος, *Thamnathaios*): The father of Samson's wife, a native of Timnah (Jgs 15 6).

**TIMON**, tī'mon (Τίμων, *Tīmōn*): One of "the seven" chosen to relieve the apostles by attending to "the daily ministration" to the poor of the Christian community in Jerus (Acts 6 5). The name is Greek, but as Nicolaüs is distinguished from the remaining six as a proselyte, Timon and the others were probably Jews by birth.

**TIMOTHEUS**, ti-mō'thē-us (Τιμόθεος, *Timótheos*):

(1) A leader of the children of Ammon who was on several occasions severely defeated by Judas Maccabaeus (1 Macc 5 6 ff.34 ff; 2 Macc 8 30; 9 3; 10 24; 12 2.18 ff) in 165-163 BC. According to 2 Macc 10 37, he was slain at Gazara after having hidden in a cistern. But in 2 Macc 12 2 he is again at liberty as an opponent of the Jews, and in 12 24 f he falls into the hands of Dositheus and Sosipater, but by representing that many Jewish captives were at his mercy and likely to suffer if he were put to death, he is again released. These discrepancies are so great—though not unusual in 2 Macc—that some suppose another Timotheus is referred to in 12 2 ff. He is most probably the same person, the careless author of 2 Macc making a slip in saying Timotheus was killed at Gazara. He probably escaped by hiding in the cistern. The Gr name for an Ammonite leader is striking: (a) he may have been a genuine Ammonite with a Gr name, or (b) a Syro-Macedonian officer placed by Syrian authority over the Ammonites, or (c) a Gr soldier of fortune invited by the Ammonites to be their commander.

(2) See next article.

S. ANGUS

**TIMOTHY**, tim'ō-thi (Τιμόθεος, *Timótheos*) [Acts 17 14; 18 5; 19 22; 20 4; Rom 16 21; 1 Cor 4 17; 16 10; 2 Cor 1 1.1.9; Phil 1 1; 2 19; Col 1 1; 1 Thess 1 1; 3 2.6; 2 Thess 1 1; 1 Tim 1 2.18; 6 20; 2 Tim 1 2; Philem ver 1;

He **13 23**; AV **Timotheus**): Timothy was one of the best known of Paul's companions and fellow-laborers. He was evidently one of Paul's own converts, as the apostle describes him as his beloved and faithful son in the Lord (1 Cor 4 17); and in 1 Tim 1 2 he writes to "Timothy my true child in faith"; and in 2 Tim 1 2 he addresses him as "Timothy my beloved child."

He was a resident, and apparently a native, either of Lystra or Derbe, cities which were visited and evangelized by Paul on his 1st missionary journey (Acts 14 6). It is probable that of these two cities, it was Lystra that was T.'s native place.

For instance, in Acts 20 4 in a list of Paul's friends there are the names of "Gaius of Derbe, and Timothy"; this evidently infers that T. was not "of Derbe." And in Acts 16 3, the brethren who gave Paul the good report of T. were "at Lystra and Iconium"; the brethren from Derbe are not mentioned. Lystra was evidently T.'s native city.

In 2 Tim 3 10.11 Paul mentions that T. had fully known the persecutions and afflictions which came to him at Antioch, at Iconium and at Lystra during the apostle's first visit to these towns; and T. seems to have been one of those who were converted at that time, as we find that on Paul's next visit to Lystra and Derbe, T. was already one of the Christians there; "He came also to Derbe and to Lystra: and behold a certain disciple was there, named Timothy" (Acts 16 1).

T. was now chosen by Paul to be one of his companions. This was at an early period in Paul's apostolic career, and it is pleasing to find that to the end of the apostle's life T. was faithful to him.

T.'s father was a heathen Greek (*Hellen*, not *Hellenist*), a Gr-speaking Jew; this fact is twice mentioned (Acts 16 1.3). His mother was a Jewess, but he had not been circumcised in infancy, probably owing to objections made by his father.

T.'s mother was called Eunice, and his grandmother Lois. Paul mentions them by name in 2 Tim 1 5; he there speaks of the unfeigned faith which was in T., and which dwelt at the first in Eunice and Lois. It is evident that Eunice was converted to Christ on Paul's 1st missionary journey to Derbe and Lystra, because, when he next visited these cities, she is spoken of as "a Jewess who believed" (Acts 16 1).

On this 2d visit to Derbe and Lystra, Paul was strongly attracted to T., and seeing his unfeigned faith, and that from a child he had known the sacred Scriptures of the Co-worker OT (2 Tim 3 15), and seeing also his Christian character and deportment, and his entire suitability for the work of the ministry, he would have him "to go forth with him" (Acts 16 3). T. acquiesced in Paul's desire, and as preliminaries to his work as a Christian missionary, both to Jew and Gentile, two things were done. In order to conciliate the Jewish Christians, who would otherwise have caused trouble, which would have weakened T.'s position and his work as a preacher of the gospel, Paul took Timothy and circumcised him. Paul was willing to agree to this being done, on account of the fact that T.'s mother was a Jewess.

It was therefore quite a different case from that of Titus, where Paul refused to allow circumcision to be performed (15 2)—Titus being, unlike T., a Gentile by birth. See **TITUS**.

The other act which was performed for T.'s benefit, before he set out with Paul, was that he was ordained by the presbytery or local council

of presbyters in Derbe and Lystra. Showing the importance which Paul assigned to this act of ordination, he refers to it in a letter to T. written many years afterward: "Neglect not the gift that is in thee, which was given thee by prophecy, with the laying on of the hands of the presbytery" (1 Tim 4 14). In this ordination Paul himself took part, for he writes, "I put thee in remembrance, that thou stir up the gift of God, which is in thee through the laying on of my hands" (2 Tim 1 6). "2 Tim 1 6 should be viewed in the light of 1 Tim 4 14. Probably it was prophetic voices (through prophecy; cf 1 Tim 1 18, 'according to the prophecies which went before in regard to thee') which suggested the choice of Timothy as assistant of Paul and Silvanus, and his consecration to this work with prayer and the laying on of hands (cf Acts 13 2 f). The laying on of hands by the presbyters (1 Tim 4 14), and that by Paul (2 Tim 1 6), are not mutually exclusive, esp. since the former is mentioned merely as an accompanying circumstance of his endowment with special grace, the latter as the efficient cause of this endowment. The churches in the neighborhood of T.'s home, according to Acts 14 23, had been furnished with a body of presbyters soon after their founding" (Zahn, *Intro to the NT*, II, 23).

Thus prepared for the work, T. went forth with Paul on the apostle's 2d missionary journey. We find T. with him at Berea (Acts 17 14), having evidently accompanied him to all places visited by him up to that point, viz. Phrygia, the region of Galatia, Mysia, Troas, Neapolis, Philippi, Amphipolis, Apollonia, Thessalonica and Berea. Paul next went—and went alone, on account of the persecution at Berea—to Athens (Acts 17 15); and from that city he sent a message to Silas and T. at Berea, that they should come to him at Athens with all speed. They quickly came to him there, and were immediately sent on an errand to the church in Thessalonica; "When we could no longer forbear, we thought it good to be left behind at Athens alone; and sent T., our brother, and minister of God, and our fellow-labourer in the gospel of Christ, to establish you, and to comfort you concerning your faith: that no man should be moved by these afflictions" (1 Thess 3 1.2.3 AV). T. and Silas discharged this duty and returned to the apostle, bringing him tidings of the faith of the Christians in Thessalonica, of their love and of their kind remembrance of Paul, and of their ardent desire to see him; and Paul was comforted (vs. 5.6.7).

Paul had left Athens before Silas and T. were able to rejoin him. He had proceeded to Corinth, and it was while the apostle was in that city, that "when Silas and Timothy came down from Macedonia, Paul was constrained by the word, testifying to the Jews that Jesus was the Christ" (Acts 18 5). T. evidently remained with Paul during the year and six months of his residence in Corinth, and also throughout this missionary journey to its end. From Corinth Paul wrote the Ep. to the Rom, and he sent them a salutation from T., "Timothy my fellow-worker saluteth you" (Rom 16 21).

In connection with this salutation from T., it should be noticed that it was Paul's custom to associate with his own name that of one or more of his companions, in the opening salutations in the Epp. T.'s name occurs in 2 Cor 1 1; Phil 1 1; Col 1 1; Philem ver 1. It is also found, along with that of Silvanus, in 1 Thess 1 1 and 2 Thess 1 1.

On Paul's 3d missionary journey, T. again accompanied him, though he is not mentioned till

7. His Ordination

"Neglect not the gift that is in thee, which was given thee by prophecy, with the laying on of the hands of the presbytery" (1 Tim 4 14). In this ordination Paul himself took part, for he writes, "I put thee in remembrance, that thou stir up the gift of God, which is in thee through the laying on of my hands" (2 Tim 1 6).

"2 Tim 1 6 should be viewed in the light of 1 Tim 4 14. Probably it was prophetic voices (through prophecy; cf 1 Tim 1 18, 'according to the prophecies which went before in regard to thee') which suggested the choice of Timothy as assistant of Paul and Silvanus, and his consecration to this work with prayer and the laying on of hands (cf Acts 13 2 f). The laying on of hands by the presbyters (1 Tim 4 14), and that by Paul (2 Tim 1 6), are not mutually exclusive, esp. since the former is mentioned merely as an accompanying circumstance of his endowment with special grace, the latter as the efficient cause of this endowment. The churches in the neighborhood of T.'s home, according to Acts 14 23, had been furnished with a body of presbyters soon after their founding" (Zahn, *Intro to the NT*, II, 23).

Thus prepared for the work, T. went forth with Paul on the apostle's 2d missionary journey. We find T. with him at Berea (Acts 17 14), having evidently accompanied him to all places visited by him up to that point, viz. Phrygia, the region of Galatia, Mysia, Troas, Neapolis, Philippi, Amphipolis, Apollonia, Thessalonica and Berea. Paul next went—and went alone, on account of the persecution at Berea—to Athens (Acts 17 15); and from that city he sent a message to Silas and T. at Berea, that they should come to him at Athens with all speed. They quickly came to him there, and were immediately sent on an errand to the church in Thessalonica; "When we could no longer forbear, we thought it good to be left behind at Athens alone; and sent T., our brother, and minister of God, and our fellow-labourer in the gospel of Christ, to establish you, and to comfort you concerning your faith: that no man should be moved by these afflictions" (1 Thess 3 1.2.3 AV). T. and Silas discharged this duty and returned to the apostle, bringing him tidings of the faith of the Christians in Thessalonica, of their love and of their kind remembrance of Paul, and of their ardent desire to see him; and Paul was comforted (vs. 5.6.7).

Paul had left Athens before Silas and T. were able to rejoin him. He had proceeded to Corinth, and it was while the apostle was in that city, that "when Silas and Timothy came down from Macedonia, Paul was constrained by the word, testifying to the Jews that Jesus was the Christ" (Acts 18 5). T. evidently remained with Paul during the year and six months of his residence in Corinth, and also throughout this missionary journey to its end. From Corinth Paul wrote the Ep. to the Rom, and he sent them a salutation from T., "Timothy my fellow-worker saluteth you" (Rom 16 21).

In connection with this salutation from T., it should be noticed that it was Paul's custom to associate with his own name that of one or more of his companions, in the opening salutations in the Epp. T.'s name occurs in 2 Cor 1 1; Phil 1 1; Col 1 1; Philem ver 1. It is also found, along with that of Silvanus, in 1 Thess 1 1 and 2 Thess 1 1.

On Paul's 3d missionary journey, T. again accompanied him, though he is not mentioned till

9. At Corinth

that "when Silas and Timothy came down from Macedonia, Paul was constrained by the word, testifying to the Jews that Jesus was the Christ" (Acts 18 5). T. evidently remained with Paul during the year and six months of his residence in Corinth, and also throughout this missionary journey to its end. From Corinth Paul wrote the Ep. to the Rom, and he sent them a salutation from T., "Timothy my fellow-worker saluteth you" (Rom 16 21).

In connection with this salutation from T., it should be noticed that it was Paul's custom to associate with his own name that of one or more of his companions, in the opening salutations in the Epp. T.'s name occurs in 2 Cor 1 1; Phil 1 1; Col 1 1; Philem ver 1. It is also found, along with that of Silvanus, in 1 Thess 1 1 and 2 Thess 1 1.

On Paul's 3d missionary journey, T. again accompanied him, though he is not mentioned till

10. Salutations

It is also found, along with that of Silvanus, in 1 Thess 1 1 and 2 Thess 1 1.

Ephesus was reached. This journey involved much traveling, much work and much time. At Ephesus alone more than two years were spent.

**11. At Ephesus** And when Paul's residence there was drawing to a close, he laid his plans to go to Jerus, after passing *en route* through Macedonia and Achaia. Accordingly he sent on before him "into Macedonia two of them that ministered unto him, Timothy and Erastus" (Acts 19 22). From Ephesus Paul wrote the First Ep. to the Cor (1 Cor 16 8), and in it he mentioned (ver 10) that T. was then traveling to Corinth, apparently a prolongation of the journey into Macedonia. After commending him to a kind reception from the Corinthians, Paul proceeded to say that T. was to return to him from Corinth; that is, T. was to bring with him a report on the state of matters in the Corinthian church.

**12. To Corinth Again** Soon thereafter the riot in Ephesus occurred; and when it was over, Paul left Ephesus and went to Macedonia and Greece. In Macedonia he was rejoined by T., whose name is associated with his own, in the opening salutation of the Second Ep., which he now wrote to Corinth. T. accompanied him into Greece, where they abode three months. From Greece the apostle once more set his face toward Jerus. T. and others accompanying him (Acts 20 4). "We that were of Paul's company" (Acts 21 8 AV), as Luke terms the friends who now traveled with Paul—and T. was one of them—touched at Troas and a number of other places, and eventually reached Jerus, where Paul was apprehended. This of course terminated, for the time, his apostolic journeys, but not the coöperation of his friends, or of T. among them.

**13. In Greece** The details of the manner in which T. was now employed are not recorded, until he is found once more with Paul—during his 1st imprisonment in Rome. But, from that point onward, there are many notices of how he was occupied in the apostle's service. He is mentioned in three of the Epp. written by Paul at this time, viz. in Col 1 1, and Philem ver 1, in both of which his designation is "Timothy our brother," and in Phil 1 1, "Paul and Timothy, servants of Christ Jesus." In Phil 2 19, there is the interesting notice that, at a time when Paul's hope was that he would soon be liberated from his imprisonment, he trusted that he would be able to send T. to visit the church at Philippi: "I hope in the Lord Jesus to send Timothy shortly unto you, that I also may be of good comfort, when I know your state. For I have no man likeminded, who will care truly for your state. . . . But ye know the proof of him, that, as a child serveth a father, so he served with me in furtherance of the gospel. Him therefore I hope to send forthwith."

**14. In Jerusalem** Paul's hope was realized: he was set free; and once again T. was his companion in travel. Perhaps it was in Philippi that they rejoined each other, for not only had Paul expressed his intention of sending T. there, but he had also said that he hoped himself to visit the Philippian church (Phil 1 26; 2 24). From this point onward it is difficult, perhaps impossible, to trace the course of Paul's journeys, but he tells us that he had left T. as his delegate or representative in Ephesus (1 Tim 1 3); and soon thereafter he wrote the First Ep. to Tim, in which he gave full instructions in regard to the manner in which he should conduct the affairs of the Ephesian church, until Paul himself should again revisit Ephesus: "These things write I unto thee, hoping to come unto thee shortly" (1 Tim 3 14).

**15. In Rome** The position which Timothy occupied in Ephesus, as it is described in 1 Tim, cannot without doing the

greatest violence to history be called that of a bishop, for the office of bishop existed only where the one bishop, superior to the presbytery, represented the highest expression of the common church life. The office was for life, and confined to the local church. This was particularly the case in Asia Minor, where, although as early as the time of Rev and the time of Ignatius, bishoprics were numerous and closely adjacent, the office always retained its local character. On the other hand, T.'s position at the head of the churches of Asia was due to the position which he occupied as Paul's helper in missionary work. It was his part in the apostolic calling, as this calling involved the oversight of existing churches. T. was acting as a temporary representative of Paul in his apostolic capacity at Ephesus, as he had done earlier in Corinth, and in Thessalonica and Philippi (1 Cor 4 17; 1 Thess 3 2 f.; Phil 2 19-23). His relation was not closer to one church than to the other churches of the province; its rise and disappearance did not affect at all the organization of the local congregations" (Zahn, *Intro to the NT*, II, 34).

**16. To Visit Philippi** From the Second Ep. still further detail can be gathered. Paul was a second time imprisoned, and feeling that on this occasion his trial would be followed by an adverse judgment and by death, he wrote from Rome to T. at Ephesus, affectionately requesting him to come to him: "Give diligence to come shortly unto me" (2 Tim 4 9). The fact that at that time, when no Christian friend was with Paul except Luke (2 Tim 4 11), it was to T. he turned for sympathy and aid, closing with the request that his own son in the faith should come to him, to be with him in his last hours, shows how true and tender was the affection which bound them together. Whether T. was able to reach Rome, so as to be with Paul before his execution, is unknown.

**17. Appointed to Ephesus** One other notice of him occurs in He 13 23: "Know ye that our brother Timothy hath been set at liberty; with whom, if he come shortly, I will see you." As the author of the Ep. to the He is not Paul, it is problematical what the meaning of these words really is, except that T. had been imprisoned, and—unlike what took place in Paul's case—he had escaped death and had been set free. Nothing further is known of him. Of all Paul's friends, with the exception, perhaps, of Luke, Paul's beloved friend, T. was regarded by him with the tenderest affection; he was his dearly loved son, faithful and true. Various defects have been alleged to exist in T.'s character. These defects are inferred from the directions and instructions addressed to him by Paul in the Pastoral Epp., but these inferences may be wrong, and it is a mistake to exaggerate them in view of his unbroken and unswerving loyalty and of the long and faithful service rendered by him to Paul, "as a child serveth a father" (Phil 2 22).

**18. His Position in Ephesus** JOHN RUTHERFURD  
**TIMOTHY, EPISTLES TO.** See PASTORAL EPISTLES.

**19. Paul Summons Him to Rome** **TIN**, tin (תִּינִי, *bdhil*): Tin is mentioned with brass, iron and lead in Nu 31 22; Ezk 22 18, 20. Ezekiel mentions tin along with silver, iron and lead as being imported into Tyre from Tarshish (see METALS; BRONZE). The tin must have been brought in the form of ore and smelted in Syria. The writer has some slag dug from a deposit near Beirût which yielded nearly pure tin. It was probably the site of an ancient smelter's shop.

**20. Mention in He 13** ALFRED ELY DAY  
**TIPSAH**, tif'sa (תִּפְסָחָה, *tiphshah*, "ford"; טַפְסָה, *Thapsá*):

(1) This marks the northern extremity of the dominions ruled by Solomon, Gaza being the limit on the S. (1 K 4 24). It can hardly be other than Thapsacus, on the right bank of the Euphrates, before its waters join those of the Balik. The great caravan route between E. and W. crossed the river by the ford at this point. Here Cyrus the younger effected a somewhat perilous crossing (Xen. *Anab.* i.4, 2). The ford was also used by Darius; but Alexander the Great, in his pursuit, constructed

(2) This marks the northern extremity of the dominions ruled by Solomon, Gaza being the limit on the S. (1 K 4 24). It can hardly be other than Thapsacus, on the right bank of the Euphrates, before its waters join those of the Balik. The great caravan route between E. and W. crossed the river by the ford at this point. Here Cyrus the younger effected a somewhat perilous crossing (Xen. *Anab.* i.4, 2). The ford was also used by Darius; but Alexander the Great, in his pursuit, constructed

two bridges for the transport of his army (Arrian iii.7). Under the Seleucidæ it was called Amphipolis. The site is probably occupied by the modern *Kal'at Dibse*, where there is a ford still used by the caravans. It is about 8 miles below Meskene, where the river makes a bend to the E.

(2) (B, *Θερσά*, *Thersá*, A, *Θαιρά*, *Thairá*): The inhabitants of this town, which was apparently not far from Tirzah, did not favor the regicide Menahem, refusing to open to him. In his wrath he massacred the Tiphsites with circumstances of horrible cruelty (2 K 15 16). *Khirbet Tafisah*, about 6 miles S.W. of *Nablus*, corresponds in name, but is probably too far from Tirzah. W. EWING

**TIRAS**, tí'ras (טִירָס, *tiras*; *Θειράς*, *Theirá*s, Luc., *Θειράς*, *Thirá*s): A son of Japheth (Gen 10 2 [P]; 1 Ch 1 5). Not mentioned elsewhere; this name was almost unanimously taken by the ancient commentators (so Jos, *Ant*, I, vi, 1) to be the same as that of the Thracians (*Θράκες*, *Thrákes*); but the removal of the nominative ending *s* does away with this surface resemblance. Tuch was the first to suggest the *Τυρσηνοί*, *Tursēniói*, a race of Pelasgian pirates, who left many traces of their ancient power in the islands and coasts of the Aegean, and who were doubtless identical with the Etruscans of Italy. This brilliant suggestion has since been confirmed by the discovery of the name *Turuša* among the seafaring peoples who invaded Egypt in the reign of Merenptah (W. M. Müller, *A E*, 356 ff). Tiras has also been regarded as the same as *Tarshish*.

HORACE J. WOLF

**TIRATHITES**, tí'rath-its (תִּירָתִיטִים, *tir'áthim*; B A, *Ἀργαθίται*, *Argathíētai*, Luc., *Θαράθει*, *Tharathēi*): A family of scribes that dwelt at Jabez (1 Ch 2 55). The three families mentioned in this verse (Tirathites, Shimathites and Sucathites) are taken by Jerome to be three different classes of religious functionaries—singers, scribes, recorders ("*cantantes atque resonantes et in tabernaculis commorantes*"). The Tg takes the same view, save that the "Sucathites" are those "covered" with a spirit of prophecy. Bertheau sees the Tirathites as "gate-keepers" (Aram. תִּירָתִיטִים, *tira'*=Heb שַׁעֲרָא, *sha'ar*). Keil holds the three names to be those of the descendants of unknown men named Tira, Shemei and Suchah. The passage seems too obscure to admit of interpretation. HORACE J. WOLF

**TIRE**, tír, **HEADTIRE** (2 K 9 30; Isa 3 20; Ezk 24 17, 23; Jth 10 3; 16 8). See DRESS, V.

**TIRES**, tírz, **ROUND**: Small ornaments in the shape of crescents (Isa 3 18 AV, RV "crescents"). See ASTRONOMY, I, 3; CRESCENTS.

**TIRHAKAH**, tēr-hā'ka, tīr-hā'ka (תִּירְחָקָה, *tir'hākāh*; B in 2 K, *Θαρά*, *Tharā*, elsewhere and in A, *Θαράκά*, *Tharaká*; Jos, *Θαράκης*, 1. Name *Tharsikēs*): The king of Cush or and Ethiopia (βασιλεὺς Αἰθιοπῶν, *basileús Prenomēn Aithiōpōn*), who opposed Sennacherib in Pal (2 K 19 9; Isa 37 9). The name of this ruler of Egypt and his native realm appears in hieroglyphics as *Taharqa*, his prenomēn being *Nefer-atmu-Ra-hu*, "Nefer-atmu-Ra protects." The Assyri form of Tirhakah is *Tarqā* or *Tarqu'u* (inscriptions of Assur-bani-pal).

Tirhakah was one of the sons, and apparently the favorite, of Piankhy II. He left his mother, and the city Napata, at the age of 20; and

2. **Origin and Length of Reign** when she followed him northward, she found him crowned as king of Egypt. As he died, after a reign of at least 26 years, in 667 BC, he must have mounted the throne about 693 BC.

The engagement between Tirhakah's army and the Assyrians is regarded as having taken place in 701 BC. Petrie explains this date by

3. **A Chronological Difficulty** supposing he acted at first for the reigning Pharaoh, his cousin Shabataka, Tirhakah not having officially become Pharaoh until the former's death in 693 BC. There is a general opinion, however, that the Assyri historians, like those of 2 K and Isa, have mingled two campaigns made by Sennacherib, one of them being after the accession of Tirhakah.

According to the OT account, Sennacherib was besieging Libnah when Tirhakah's army appeared in Pal. In Sennacherib's inscriptions, however, the battle with "the king[s] of Musuru [Egypt] and the bowmen, chariots, and cavalry of Meruhha," Assyrians to Hezekiah's help, took place in the neighborhood of Eltekeh. He claims to have captured the sons of the king (variant, "kings") of Egypt and the charioteers of the king of Meruhha, and then, having taken Eltekeh, Timna, and Ekron, he brought out Padf from Jerus, and reseated him on the throne of Ekron. The name of Tirhakah does not occur in his account.

It would seem to have been Egypt's interference in Palestinian affairs which caused the Assyri kings to desire the conquest of that distant country. According to the Bab Chron-

4. **First Conflict with the Assyrians** with the Assyrians haddon and in the 7th year of Esar-haddon (675 Assur-bani-BC), and the country was then apparently quiet until 672 BC, when Esar-haddon marched thither, and after

5. **Struggles** fighting three battles, entered Memphis. "The king" (Tirhakah) fled, but his sons and nephews were made prisoners. In the latter campaign (670 BC), Esar-haddon fell ill and died on the way out, so that the operations were, apparently, completed by his son, Assur-bani-pal (Osnappar). On hearing of the Assyri success at Karbaniti, Tirhakah, who was at Memphis, fled to Thebes. The 20 petty kings installed in Egypt by Esar-haddon were restored by Assur-bani-pal, but they feared the vengeance of Tirhakah after the Assyri army had retired, and therefore made an agreement with him. On this news reaching the Assyri king, he sent his army back to Egypt, and the petty rulers having been abolished, Necho king of Memphis and Sais was set on the throne, with his son, Nabû-shzibanni, as ruler in Atrihbes. On hearing of the success of the Assyri armies, Tirhakah fled, and died in Cush (Ethiopia). He was succeeded by Tanamanē (identified with Tanut-Amon), son of Sabaco, whom the Assyrians defeated in the last expedition which they ever made to Egypt (see W. F. Petrie, *Hist of Egypt*, III, 294 ff). T. G. PINCHES

**TIRHANA**, tūr'ha-nā, tēr-hā'nā (תִּירְחָנָה, *tir'hānāh*; B, *Θαράμ*, *Tharām*, A, *Θαρχνά*, *Tharchnā*, Luc., *Θαραανά*, *Tharaanā*): A son of Caleb by his concubine, Maacah (1 Ch 2 48).

**TIRIA**, tír'i-a, tí'r-i-a (תִּירְיָא, *tiryā'*, Baer תִּירְיָא, *tiryā'*; B omits, A, *Θηριά*, *Thēriá*, Luc., *Ἐθριά*, *Ethriá*): A son of Jehalelel (1 Ch 4 16).

**TIRSHATHA**, tēr-shā'tha, tūr-sha'tha (תִּירְשָׁתָה, *tirshāthā'*; *Ἄθηραθά*, *Hathersathá*): A title which occurs 5 t in Ezr and Neh (Ezr 2 63; Neh 7 65, ARV and ERVM "governor"). In Neh 8 9; 10 1, Nehemiah is called the *tirshāthā'*. In Ezr 2 63; Neh 7 65, 70, it is the title of Sheshbazzar, or Zerubabel. As in Neh 12 26, Nehemiah is called a *pehāh*,

or governor, a title which in Ezr 5 14 is given to Sheshbazzar also, it has been supposed that *pehāh* and *tirshāthā* were equivalent terms, the former being of Assyrio-Bab and the latter of Pers origin. According to Lagarde, it comes from the Bactrian *antarekshatra*, that is, "he who takes the place of the king." According to Meyer and Scheftelowitz it is a modified form of a hypothetical Old Pers word *tarsata*. According to Gesenius and Ewald, it is to be compared with the Pers *torsh*, "severe," "austere," i.e. "stern lord." It seems more probable that it is derived from the Bab  $\sqrt{r}$  *rashu*, "to take possession of," from which we get the noun *rashu*, "creditor." In this case it may well have had the sense of a tax-collector. One of the principal duties of the Pers satrap, or governor, was to assess and collect the taxes (see Rawlinson's *Persia*, ch viii). This would readily account for the fact that in Neh 7 70 the *tirshāthā* gave to the treasure to be used in the building of the temple a thousand drachms of gold, etc, and that in Ezr 1 8 Cyrus numbered the vessels of the house of the Lord unto Sheshbazzar. This derivation would connect it with the Aram. *rashya*, "creditor," and the New Heb *rāshūh*, "highest power," "magistrate."

R. DICK WILSON

**TIRZAH**, tūr'za (תִּרְצַח, *tirṣāh*; Θερσά, *Thersá*):

(1) A royal city of the Canaanites, the king of which was slain by Joshua (12 24). It superseded Shechem as capital of the Northern Kingdom (1 K 14 17, etc), and itself gave place in turn to Samaria. Here reigned Jeroboam, Nadab his son, Baasha, Elah and Zimri (15 21.33; 16 6.8.9.15). Baasha was buried in Tirzah. Here Elah was assassinated while "drinking himself drunk" in the house of his steward; here therefore probably he was buried. Zimri perished in the flames of his palace, rather than fall into Omri's hands. In Tirzah Menahem matured his rebellion against Shallum (2 K 15 14). The place is mentioned in Cant 6 4 AV, where the Shulamite is said to be "beautiful . . . as Tirzah, comely as Jerus." The comparison may be due to the charm of its situation. The name may possibly be derived from *rāṣāh*, "to delight." Several identifications have been suggested. Buhl (*GAP*, 203) favors *et-Tirēh*, on the W. of the plain of *Makhneh*, 4 miles S. of *Nāblus*, which he identifies with the *Tirathana* of Jos. He quotes Neubauer to the effect that the later Jews said *Tir'an* or *Tar'ita* instead of Tirzah, as weakening the claim of *Tellūzah*, which others (e.g. Robinson, *BR*, III, 302) incline to. It is a partly ruined village with no spring, but with ancient cisterns, on a hill about 4 miles E. of N. from *Nāblus*. This was evidently the place intended by Brocardius—Thersa, about 3 miles E. of Samaria (*Descriptio*, VII). A third claimant is *Teiast*, a fortress at the point where the road from Abel-meholah joins that from Shechem to Bethshan, fully 11 miles N.E. of *Nāblus*. It is impossible to decide with certainty. The heavy  $\xi$  in *Tellūzah* is a difficulty. *Teiast* is perhaps too far from Shechem. Buhl's case for identification with *et-Tirēh* is subject to the same difficulty as *Tellūzah*.

(2) One of the five daughters of Zelophehad (Nu 26 33; 27 1; 36 11; Josh 17 3). W. EWING

**TISHBITE**, tish'bīt. See ELIJAH; *Expos T*, XII, 383.

**TISHRI**, tish'rē, **TISRI**, tiz'rē: The 7th month of the Jewish ecclesiastical, and 1st of the civil, year (September-October). The same as Ethanim. See CALENDAR.

**TITANS**, tī'tanz: In Jth 16 7, "Neither did the sons of the Titans [*υἱοὶ Τίτάνων*, *huiōi Titánōn*] smite him." The name of an aboriginal Canaan-

ish race of reputed giants who inhabited Pal before the Hebrews, and so used in the sense of "giants" in general. See REPHAIM. In 2 S 5 18.22, the "valley of Rephaim" is tr'd by LXX as "the valley of the Titans."

**TITHE**, tith (תְּשֻׁבָה, *ma'āsēr*; δεκάτη, *dekátē*):

The custom of giving a 10th part of the products of the land and of the spoils of war to priests and kings (1 Macc 10 31; 11 35; 1 S 8 15.17) was a very ancient one among most nations. That the Jews had this custom long before the institution of the Mosaic Law is shown by Gen 14 17-20 (cf He 7 4) and Gen 28 22. Many critics hold that these two passages are late and only reflect the later practice of the nation; but the payment of tithes is so ancient and deeply rooted in the history of the human race that it seems much simpler and more natural to believe that among the Jews the practice was in existence long before the time of Moses.

In the Pent we find legislation as to tithes in three places. (1) According to Lev 27 30-33, a tithe had to be given of the seed of the land, i.e. of the crops, of the fruit of the tree, e.g. oil and wine, and of the herd or the flock (cf Dt 14 22.23; 2 Ch 31 5.6). As the herds and flocks passed out to pasture they were counted (cf Jer 33 13; Ezk 20 37), and every 10th animal that came out was reckoned holy to the Lord. The owner was not allowed to search among them to find whether they were bad or good, nor could he change any of them; if he did, both the one chosen and the one for which it was changed were holy. Tithes of the herds and flocks could not be redeemed for money, but tithes of the seed of the land and of fruit could be, but a 5th part of the value of the tithe had to be added. (2) In Nu 18 21-32 it is laid down that the tithe must be paid to the Levites. (It should be noted that according to He 7 5, 'they that are of the sons of Levi, who receive the office of the priesthood . . . take tithes of the people.' Westcott's explanation is that the priests, who received from the Levites a tithe of the tithe, thus symbolically received the whole tithe. In the time of the second temple the priests did actually receive the tithes. In the Talm [*Yebhāmōth* 86a *et passim*] it is said that this alteration from the Mosaic Law was caused by the sin of the Levites, who were not eager to return to Jerus, but had to be persuaded to do so by Ezra [Ezr 8 15].) The Levites were to receive the tithes offered by Israel to Jeh, because they had no other inheritance, and in return for their service of the tabernacle (Nu 18 21.24). The tithe was to consist of corn of the threshing-floor and the fulness of the wine press (ver 27), which coincides with seed of the land and fruit of the trees in Lev 27. The Levites, who stood in the same relation to the priests as the people did to themselves, were to offer from this their inheritance a heave offering, a tithe of a tithe, to the priests (cf Neh 10 39), and for this tithe they were to choose of the best part of what they received. (3) In Dt 12 5.6.11.18 (cf Am 4 4) it is said that the tithe is to be brought "unto the place which Jeh your God shall choose out of all your tribes, to put his name there," i.e. to Jerus; and in vs 7.12.18, that the tithe should be used there as a sacred meal by the offerer and his household, including the Levite within his gates. Nothing is said here about tithing cattle, only corn, wine and oil being mentioned (cf Neh 10 36-38; 13 5.12). In Dt 14 22-29 it is laid down that if the way was too long to carry the tithe to Jerus it could be exchanged for money, and the money taken there instead, where it was to be spent in anything the owner chose; and whatever was bought was to be eaten by him and his household and the Levites at Jerus. In

the third year the tithe was to be reserved and eaten at home by the Levite, the stranger, the fatherless and the widow. In 26 12-15 it is laid down that in the 3d year, after this feast had been given, the landowner should go up himself before the Lord his God, i.e. to Jerus, and ask God's blessing on his deed. (According to the Mish, *Šōtāh* 9 10; *Ma'āsēr Shēnī* 5 65, the high priest Johanan abolished this custom.) In this passage this 3d year is called "the year of tithing."

There is thus an obvious apparent discrepancy between the legislation in Lev and Dt. It is harmonized in Jewish tradition, not only theoretically but in practice, by considering the tithes as three different tithes, which are named the First Tithe, the Second Tithe, and the Poor Tithe, which is called also the Third Tithe (*Pē'āh*, *Ma'āsērōth*, *Ma'āsēr Shēnī*, *D'ma'ī*, *Rō'sh ha-shānāh*; cf Tob 1 7.8; *Ant*, IV, iv, 3; viii, 8; viii, 22). According to this explanation, after the tithe (the First Tithe) was given to the Levites (of which they had to give the tithe to the priests), a Second Tithe of the remaining nine-tenths had to be set apart and consumed in Jerus. Those who lived far from Jerus could change this Second Tithe into money with the addition of a 5th part of its value. Only food, drink or ointment could be bought for the money (*Ma'āsēr Shēnī* 2 1; cf Dt 14 26). The tithe of cattle belonged to the Second Tithe, and was to be used for the feast in Jerus (*Z'bhāhīm* 5 8). In the 3d year the Second Tithe was to be given entirely to the Levites and the poor. But according to Jos (*Ant*, IV, viii, 22) the "Poor Tithe" was actually a third one. The priests and the Levites, if landowners, were also obliged to give the Poor Tithe (*Pē'āh* 1 6).

The explanation given by many critics, that the discrepancy between Dt and Lev is due to the fact that these are different layers of legislation, and that the Levitical tithe is a post-exilian creation of the PC, is not wholly satisfactory, for the following reasons: (1) The allusion in Dt 18 1.2 seems to refer to the Levitical tithe. (2) There is no relation between the law of Nu 18 and post-exilian conditions, when the priests were numerous and the Levites a handful. (3) A community so poor and disaffected as that of Ezra's time would have refused to submit to a new and oppressive tithe burden. (4) The division into priests and Levites cannot have been of the recent origin that is alleged. See LEVITES.

W. R. Smith and others suggest that the tithe is simply a later form of the first-fruits, but this is difficult to accept, since the first-fruits were given to the priest, while the tithes were not. The whole subject is involved in considerable obscurity, which with our present information cannot easily be cleared away.

The Talmudic law of tithing extends the Mosaic Law, with most burdensome minuteness, even to the smallest products of the soil. Of these, according to some, not only the seeds, but, in certain cases, even the leaves and stalks had to be tithed (*Ma'āsērōth* 4 5), "mint, anise, and cummin" (*D'ma'ī* 11 1; cf Mt 23 23; Lk 11 42). The general principle was that "everything that is eaten, that is watched over, and that grows out of the earth" must be tithed (*Ma'āsērōth* 1 1).

Considering the many taxes, religious and secular, that the Jews had to pay, esp. in post-exilian times, we cannot but admire the liberality and resourcefulness of the Jewish people. Only in the years just after the return from exile do we hear that the taxes were only partially paid (Neh 13 10; cf Mal 1 7 ff; and for pre-exilian times of 2 Ch 31 4 ff). In later times such cases seldom occur (*Šōtāh* 48a), which is the more surprising since the priests, who benefited so much by these laws of the scribes, were the adversaries of the latter.

PAUL LEVERTOFF

**TITIVS JUSTUS**, tish'us jus'tus. See JUSTUS, (2); TITUS JUSTUS.

**TITLE**, tī't'l: Jn 19 19.20 for *τίτλος*, *titlos*.

The following arrangement of the title on the cross has been suggested:

ישוע הנצרי מלך היהודים  
OYTOC ECTIN IHCOYC O BACILEYC  
TWN IOYΔAIWN  
REX JUDAEORUM

See Geikie, *Life and Words of Christ*, ch lxiii, note e; Seymour, *The Cross in Tradition, History and Art* (New York, 1898), pp. 115, 116, 136, 138.

In 2 K 23 17, AV has "title" for צִיּוּן, *ḥiyūn*. The word is connected with *ḥāwāh*, "to command," and AV seems to have understood *ḥiyūn* as "that giving directions," "sign-posts" (cf Ezk 39 15). The word, however, means "grave-stone," "monument." See SUPERScription.

**TITTLE**, tīt'l (κεράτα, *keráta* [WH, *keréa*], from *kéras*, *kéras*, "a horn"): A small stroke or mark, specif. on a letter to denote accent, or as a diacritical mark; used only in Mt 5 18 and Lk 16 17. In the first passage it is used in connection with iota, or jot, i.e. the very smallest thing, and in both it refers to the minutiae of the Law. It is well known that the scribes paid the greatest attention to such marks attached to the letters in the Heb Scriptures, the MT of which abounds in them. See Jor; YODH.

**TITUS**, tī'tus (Τίτος, *Títos* [2 Cor 2 13; 7 6.13 ff; 8 6.16.23; 12 18; Gal 2 1.3; 2 Tim 4 10; Tit 1 4]):

A Gr Christian, one of Paul's intimate friends, his companion in some of his apostolic journeys, and one of his assistants in Christian work. His name does not occur in the Acts; and, elsewhere in the NT, it is found only in 2 Cor, Gal, 2 Tim and Tit. As Paul calls him "my true child after a common faith" (Tit 1 4), it is probable that he was one of the apostle's converts.

The first notice of T. is in Acts 15 2, where we read that after the conclusion of Paul's 1st missionary journey, when he had returned to

2. Paul Antioch, a discussion arose in the church there, in regard to the question whether it was necessary that gentile Christians should be circumcised and should keep the Jewish Law. It was decided that Paul and Barnabas, "and certain other of them," should go up to Jerus to the apostles and elders about this question. The "certain other of them" includes T., for in Gal 2 3 it is recorded that T. was then with Paul. The Judaistic party in the church at Jerus desired to have T. circumcised, but Paul gave no subjection to these persons and to their wishes, "no, not for an hour; that the truth of the gospel might continue with you" (Gal 2 5). The matter in dispute was decided as recorded in Acts 15 13-29. The decision was in favor of the free promulgation of the gospel, as preached by Paul, and unrestricted by Jewish ordinances. Paul's action therefore in regard to T. was justified. In fact T. was a representative or test case.

It is difficult and perhaps impossible to give the true reason why Titus is not mentioned by name in the Acts, but he is certainly referred to in 15 2. There is no further notice of T. for some years afterward, when he is again mentioned in 2 Cor. In this Ep. his name occurs 8 t. From the notices in this Ep. it appears that T. had been sent by Paul, along with an unnamed "brother," to Corinth



as the apostle's delegate to the church there (2 Cor 12 18). His chief business was evidently to deal with the cases of immorality which had occurred there. His mission was largely successful, so that he was able to return to Paul with joy, because his spirit was refreshed by the Corinthians (2 Cor 7 13). His inward affection was largely drawn out to them, and "he remembereth the obedience of you all, how with fear and trembling ye received him" (7 15). At Corinth T. seems also to have assisted in organizing the weekly collections for the poor saints in Jerus. See 1 Cor 16 1.2 compared with 2 Cor 8 6: "We exhorted Titus, that as he had made a beginning before, so he would also complete in you this grace also."

After the departure of T. from Corinth, difficulty had again arisen in the church there, and T. seems to have been sent by Paul a second time to that city, as the apostle's messenger, carrying a letter from him—referred to in 2 Cor 2 3 ff; 7 8 ff.

The state of the Corinthian church had been causing much anxiety to Paul, so much so that when he had come to Troas to preach Christ's gospel, and a door was opened to him of the Lord, he found no rest in his spirit, because he found not T., his brother; so he left Troas, and went thence into Macedonia, in order to meet T. the sooner, so as to ascertain from him how matters stood in Corinth. In Macedonia accordingly the apostle met T., who brought good news regarding the Corinthians. In the unrest and fightings and fears which the troubles at Corinth had caused Paul to experience, his spirit was refreshed when T. reached him. "He that comforteth the lowly, even God, comforted us by the coming of Titus . . . while he told us your longing, your mourning, your zeal for me; so that I rejoiced yet more" (2 Cor 7 6.7).

Paul now wrote to the Corinthians again—our Second Ep. to the Cor—and dispatched it to its destination by the hand of T., into whose heart 'God had put the same earnest care for them' (2 Cor 8 16-18). T. was also again intrusted with the work of overseeing the weekly collection in the Corinthian church (2 Cor 8 10.24).

There is now a long interval in the history of T., for nothing further is recorded of him till we come to the Pastoral Epp. From Paul's

**5. Travels with Paul to Crete** Ep. to him these details are gathered: On Paul's liberation at the conclusion of his first Rom imprisonment he made a number of missionary journeys, and T. went with him, as his companion and assistant, on one of these—to the island of Crete. From Crete, Paul proceeded onward but he left T. to "set in order the things that were wanting, and appoint elders in every city" (Tit 1 5). Paul reminds him of the character of the people of Crete, and gives him various instructions for his guidance; charges him to maintain sound doctrine, and advises him how to deal with the various classes of persons met with in his pastoral capacity.

T. is informed that Artemas or Tychicus will be sent to Crete so that he will be free to leave the island and to rejoin the apostle at Nicopolis, where he has determined to winter. Such were Paul's plans; whether they were carried out is unknown. But this at least is certain, that T. did rejoin Paul, if not at Nicopolis, then at some other spot; and

**6. Paul Sends for Him** he was with him in Rome on the occasion of his 2d imprisonment there, for he is mentioned once again (2 Tim 4 10) as having gone to Dalmatia, evidently on an evangelistic errand, as the apostle was in the habit of sending his trusted friends to do such work, when he himself was no longer able to do this, owing to his imprisonment. "Paul regarded as his own the work done from centers where he labored, by helpers associated

with him, considering the churches thus organized as under his jurisdiction. This throws light upon the statement in 2 Tim 4 10, that T. at that time had gone to Dalmatia, and a certain Crescens to Gaul. There is no indication that they, like Demas, had deserted the apostle and sought safety for themselves, or that, like Tychicus, they had been sent by the apostle upon some special errand. In either case it would be a question why they went to these particular countries, with which, so far as we know, Paul, up to this time, had never had anything to do. The probability is that T., who had long been associated with Paul (Gal 2 3), who, as his commissioner, had executed difficult offices in Corinth (2 Cor 7-9), and who, not very long before 2 Tim was written, had completed some missionary work in Crete that had been begun by others, had gone as a missionary and as Paul's representative and helper to Dalmatia. . . . If by this means, beginnings of church organizations had been made . . . in Spain by Paul himself, in Gaul by Crescens, in Dalmatia by T., then, in reality, the missionary map had been very much changed since Paul's first defence" (Zahn, *Intro to the NT*, II, 11).

T. was one of Paul's very dear and trusted friends; and the fact that he was chosen by the apostle to act as his delegate to Corinth, to trans-

**7. His Character** act difficult and delicate work in the church there, and that he did this oftener than once, and did it thoroughly and successfully, shows that T. was not merely a good but a most capable man, tactful and resourceful and skilful in the handling of men and of affairs. "Whether any inquire about T., he is my partner and fellow-worker to you-ward" (2 Cor 8 23). JOHN RUTHERFURD

**TITUS, EPISTLE TO.** See PASTORAL EPISTLES.

**TITUS** or **TITIUS JUSTUS** (Τίτος or Τίτιος Ἰούσττος, *Titos* or *Títios Iúistos* [Acts 18 7]): Titus or Titius—for the MSS vary in regard to the spelling—was the phenomen of a certain Corinthian, a Jewish proselyte (*sebómenos tón Theón*. See PROSELYTE). His name seems also to indicate that he was a Roman by birth. He is altogether a different person from Titus, Paul's assistant and companion in some of his journeys, to whom also the Ep. to Tit is addressed.

Titus or Titius Justus was not the "host of St. Paul at Corinth" (*HDB*, art. "Justus," p. 511), for Luke has already narrated that, when Paul came to Corinth, "he abode with" Aquila and Priscilla (Acts 18 3). What is said of Titius Justus is that when the Jews in Corinth opposed themselves to Paul and blasphemed when he testified that Jesus was the Christ, then Paul ceased to preach the gospel in the Jewish synagogue as he had formerly done, and "he departed thence, and went into the house of a certain man named Titus Justus, one that worshipped God, whose house joined hard to the synagogue" (ver 7).

"Titius Justus was evidently a Roman or a Latin, one of the *coloni* of the colony Corinth. Like the centurion Cornelius, he had been attracted to the synagogue. His citizenship would afford Paul an opening to the more educated class of the Corinthian population" (Ramsay, *St. Paul the Traveller and the Rom Citizen*, 256).

Paul's residence in Corinth continued for a year and a half, followed without a break by another period indicated in the words, he "tarried after this yet many days" (Acts 18 11.18), and during the whole of this time he evidently used the house of Titius Justus, for the purposes both of preaching the gospel and of gathering the church together for Christian worship and instruction, "teaching the word of God among them" (ver 11).

Titius Justus, therefore, must have been a wealthy man, since he possessed a house in which there was an apartment sufficiently large to be used for both of these purposes; and he himself must have been a most enthusiastic member of the church, when in a period of protracted difficulty and persecution, he welcomed Paul to his house, that he might use it as the meeting-place of the church in Corinth. See JUSTUS, (2).

JOHN RUTHERFURD

TITUS MANIUS. See MANIUS.

TIZITE, tī'zīt (תִּיצִיט, ha-tīzī; B, ó 'Icauel, ho Icael, A, ó Θωραελ, ho Thōsael, Luc., Ἀθωρα, Athōsī): A gentile attached to the name "Joha" (1 Ch 11 45), one of the soldiers of David; the origin is totally unknown.

TOAH, tō'a. See NAHATH.

TOB, tob, tōb, THE LAND OF (טוֹב אֶרֶץ, 'erec tōbh, "a good land"; γῆ Τῶβ, gé Tōb): Hither Jephthah escaped from his brethren after his father's death (Jgs 11 3), and perfected himself in the art of war, making forays with "the vain fellows" who joined him. Here the elders of Gilead found him, when, reduced to dire straits by the children of Ammon, they desired him to take command of their army (vs 5 ff). This country contributed 12,000 men to the forces of the allies, who with the Ammonites were defeated by Israel (2 S 10 8). In 1 Macc 5 13 we read of the land of Tubias where the Jews, about 1,000 men, were slain by the Gentiles, their wives and children being carried into captivity. The Tubieni, "men of Tob" of 2 Macc 12 17, were probably from this place. Ptolemy (v.19) speaks of Thaubā, a place to the S.W. of Zebah, which may possibly be Tob. The Talm (Neubauer, Géog. du Talm, 239) identifies the land of Tob with the district of Hippene. Tob would then be represented by Hippos, modern Susiyeh, to the S.W. of Fik on the plateau E. of the Sea of Galilee. Perhaps the most likely identification is that supported by G. A. Smith (HGHL, 587), with et-Taiyibeh, 10 miles S. of Umm Keis (Gadara). The name is the same in meaning as Tob. W. EWING

TOB-ADONIJAH, tob-ad-ō-nī'ja, tōb- (טוֹב אֲדוֹנִיָּה, tōbh 'ādōnīyāh, "good is the Lord"; B, Τωβαδωβειά, Tōbadōbeíá, A and Luc., Τωβαδωνά, Tōbadōnā): One of the Levites sent by King Jehoshaphat to teach in the cities of Judah (2 Ch 17 8). The name looks like a dittography arising from the two previous names, Adonijah and Tobijah.

TOBIAH, tō-bī'a (טוֹבִיָּה, tōbhīyāh; A, Τωβίας, Tōbías, omitted in B):

(1) An Ammonite slave (AV "servant"), probably of Sanballat, the governor of Samaria (Neh 2 10). He was grieved exceedingly when Nehemiah came to seek the welfare of the children of Israel. In two ways he was connected by marriage with the Jews, having himself married the daughter of Shecaniah, the son of Arah, and his son Jehohanan having married the daughter of Meshullam, the son of Berechiah (6 18). Because of this close connection with the Jews, the nobles of the latter corresponded by letter with him and also reported his good deeds to Nehemiah and reported Nehemiah's words to Tobiah. In consequence of the report, Tobiah sent letters to Nehemiah to put him in fear (6 17-19). Nehemiah seems to have considered him to be his chief enemy; for he put him before Sanballat in his prayers to God to remember his opponents according to their works (6 14). In 13 4 we are told that he was an ally of Eliashib, the high priest who had the oversight of the chambers of the house of God and had prepared for him as a guest chamber the room which had before been used as a storehouse for offerings of various kinds. Nehemiah, having heard during his second visit to Jerus of this desecration of the temple, cast out the household stuff of Tobiah and cleansed the chambers, restoring the vessels of God and the offerings as of old.

(2) The eponym of a family which returned with

Zerubbabel, but could not trace its descent (Ezr 2 60; Neh 7 62). R. DICK WILSON

TOBIAS, tō-bī'as:

- (1) The son of Tobit. See TOBIT, BOOK OF.
(2) Τωβίας, Tōbías, A, Τωβίω, Tōbīō, the father (according to Jos, grandfather) of HYRCANUS (q.v.) (2 Macc 3 11).

TOBIE, tō'bi. See TUBIAS.

TOBIEEL, tō-bī'el, tō'bī-el (Τοβιήλ, Tōbiēl, A, Τωβιήλ, Tōbiēl): The father of Tobit (Tob 1 1); another form of "Tabeel," "God is good."

TOBIJAH, tō-bī'ja (טוֹבִיָּה, tōbhīyāh, "Yahweh is good"):

- (1) A Levite in the reign of Jehoshaphat whom the king sent to teach in the cities of Judah (2 Ch 17 8; טוֹבִיָּהוּ, tōbhīyāhū; LXX omits).
(2) One of a party of Jews that came from Babylon to Jerus with gold and silver for a crown for Zerubbabel and Joshua, or for Zerubbabel alone (Zec 6 10.14). The crown was to be stored in the temple in remembrance of the donors (LXX in both passages translates טוֹבִיָּה by χρησισμοί, chrēsismoī, i.e. טוֹבִיָּה, tōbheyhā).

TOBIT, tō'bit, BOOK OF:

Table with 2 columns: 1. Name, 2. Canonicity, 3. Contents, 4. Fact or Fiction?, 5. Some Sources, 6. Date, 7. Place of Composition, 8. Versions, 9. Original Language, LITERATURE

The book is called by the name of its principal hero which in Gr is Τάβιτ, Tōbit, Τωβελτ, Tōbēlt and (N) Τωβελθ, Tōbēith. The original Heb

1. Name word thus transliterated (טוֹבִיָּה, tōbhīyāh) means "Yahweh is good." The Gr name of the son is Τωβίας, Tōbías, a variant of the same Heb word. In the Eng., Welsh, etc, trs, the father and son are called Tobit and Tobias respectively, but in the Vulg both are known by the same name—Tobias—the cause of much confusion. In Syr the father is called Tōbī, the son Tōbiya, following apparently the Gr; the former is not a transliteration of the Heb form given above and assumes a different etymology, but what?

Though this book is excluded from Protestant Bibles (with but few exceptions), Tob 4 7-9 is read in the Anglican offertory, and at one

2. Canon- time Tobias and Sarah occupied in the marriage service of the Anglican rubrics the position at present held by Abraham and Sarah. For the position of the book in the LXX, Vulg and EV, see JUDITH, 2.

The Book of Tob differs in essential matters in its various VSS and even in different MSS of the same VSS (cf LXX). The analysis

3. Contents of the book which follows is based on the LXX MSS BA, which EV follows. The Vulg differs in many respects.

The book tells of two Jewish families, living, one at Nineveh, the other at Ecbatana, both of which had fallen into great trouble, but at length recovered their fortunes and became united by the marriage of the son of one to the daughter of the other. Tobit had, with his brethren of the tribe of Naphtali, been taken captive by Ene-messar (=Shalmaneser), remaining in exile under his two successors, Sennacherib and Sarchedonus (Esarhaddon). During his residence in the Northern Kingdom (Israel) and after his removal to Nineveh (Assyria), he continued faithful to the Jewish religion and supported the observances of that religion at Jerus. Moreover, he fasted regularly, gave alms freely, and buried such of his fellow-countrymen as had been put to death with the approval or by the command of the Assy king. Notwithstanding this loyalty to the religion of his fathers and the fact that he buried Jewish corpses intended to be

disgraced by exposure, he like other Jews (Daniel, etc) won favor at court by his upright demeanor and was made steward of the king's estate. Under the next king (Sennacherib) all this was changed, for he not only lost his high office but was deprived of his wealth, and came perilously near to losing his life. Through an accident (bird dung falling into his eyes) he lost his sight, and, to make bad worse, his wife, in the manner of Job's, taunted him with the futility of his religious faith. Job-like he prayed that God might take him out of his distress.

Now it happened that at this time another Jewish family, equally loyal to the ancestral faith, had fallen into similar distress—Raguel, his wife Edna and his daughter Sarah, who resided at Echatana (Vulg "Rages"; cf 1 14) in Media. Now Sarah was an only daughter, comely of person and virtuous of character. She had been married to seven successive husbands, but each one of them had been slain on the bridal night by the demon Asmodeus, who seems to have been eaten up with jealousy and wished no other to have the charming maid whom he loved. The parents of Tobias at Nineveh, like those of Sarah at Echatana, wished to see their only child married that they might have descendants, but the marriage must be in each case to one belonging to the chosen race (3 7-15; but see 7, below). The crux of the story is the bringing together of Tobias and Sarah and the frustration of the jealous murders of Asmodeus. In the deep poverty to which he had been reduced Tobit bethought himself of the money (ten talents, i.e. about £3,500) which he had deposited with one Gabael of Rages (LXX A B, *Rhagoi*) in Media (see 1 14). This he desired his son to fetch; but the journey is long and dangerous, and he must have a trustworthy guide which he finds in Raphael, an angel sent by God, but who appears in the guise of an orthodox Jew. The old man is delighted with the guide, whom, however, he first of all carefully examines, and dismisses his son with strict injunctions to observe the Law, to give alms and not to take to wife a non-Jewish (EV "strange") maiden (4 3 f). Proceeding on the journey they make a halt on reaching the Tigris, and during a bath in the river Tobias sees a fish that made as if it would devour him. The angel tells him to seize the fish and to extract from it and carefully keep its heart, liver and gall. Reaching Echatana they are hospitably lodged in the home of Raguel, and at once Tobias falls madly in love with the beautiful daughter Sarah, and desires to have her for wife. This is approved by the girl's parents and by Raphael, and the marriage takes place. Before going together for the night the angel instructs the bridegroom to burn the heart and liver of the fish he had caught in the Tigris. The smoke that resulted acted as a countercharm, for it drove away the evil spirit who nevermore returned (8 1 f). At the request of Tobias, Raphael leaves for Rages and brings from Gabael the ten talents left in his charge by Tobit. Tobias and his bride led by the angel now set out for Nineveh amid the prayers and blessings of Raguel and with half his wealth. They are warmly welcomed by the aged and anxious parents Tobit and Anna, and Tobias' dog which he took with him (5 16) was so pleased upon getting back to the old home that, according to the Vulg rendering, he "ran on before as if bringing the news . . . showing his joy by fawning and by wagging his tail . . ." (Vulg 11 9; cf EV 11 4). Upon reaching his father, acting upon Raphael's directions, Tobias heals Tobit's demon-caused blindness by applying to the old man's eyes the gall of the fish, whereupon sight returns and the family's cup of happiness is full. The angel is offered a handsome fee for the services he has rendered, but, refusing all, he declares who he is and why he was sent by God, who deserves all the praise, he none. Tobit, having a presentiment of the coming doom of Nineveh, urges his son to leave the country and make his home in Media after the death of his parents. Tobias is commanded to write the events which had happened to him in a book (12 20). We then have Tobit's hymn of praise and thanksgiving and a record of his death at the age of 158 years (chs 13, 14). Tobias and Sarah, in accordance with Tobit's advice, leave for Echatana. His parents-in-law follow his parents into the other world, and at the age of 127 he himself dies, though not before hearing of the destruction of Nineveh by Nebuchadnezzar (14 13-15).

Luther seems to have been the first to call in question the literal historicity of this book, regarding it rather in the light of a didactic romance. The large number of details pervading the book, personal, local and chronological, give it the appearance of being throughout a historical record; but this is but part of the author's art. His aim is to interest, instruct and encourage his readers, who were apparently in exile and had fallen upon evil times. What the writer seeks to make clear is that if they are faithful to their religious duties, giving themselves to prayer and almsgiving, bury-

ing their dead instead of exposing them on the "Tower of Silence," as did the Persians, then God would be faithful to them as He had been to Tobit.

That the book was designed to be a book of religious instruction and not a history appears from the following considerations: (1) There are historical and geographical inaccuracies in the book. It was not Shalmaneser (Ene-messar) who made the tribes of Naphtali and Zebulun exiles in Assyria, but Tiglath-pileser (734); see 2 K 15 29. Sennacherib was not the son of Shalmaneser (1 15), but of Sargon the Usurper. Moreover, the Tigris does not lie on the way from Nineveh to Echatana, as chs 6 f imply.

(2) The prominence given to certain Jewish principles and practices makes it clear that the book was written on their account. See 1 3 f, Tobit's integrity, his support of the Jerus sanctuary, his almsgiving, etc.: (a) he buries the dead bodies of Jews; (b) he and his wife pray; (c) he teaches Tobias to keep the Law, give alms, etc. Note in particular the teaching of Raphael the angel (12 6 f) and that contained in Tobit's song of praise (ch 13).

(3) The writer has borrowed largely from other sources, Bib. and non-Bib., and he shows no regard for correctness of facts so long as he succeeds in making the teaching clear and the tale interesting. The legend about the angel who pretended to be an orthodox Jew with a proper Jewish name and pedigree was taken from popular tradition and could hardly have been accepted by the writer as literally true.

For oral and written sources used by the author of Tob see the next section. A writer whose aim was to give an exact account of things which happened would hardly have gone to so many sources belonging to such different times, nor would he bring into one life events which in the sources belong to many lives (Job, etc).

The Book of Tob is dependent upon older sources, oral or written, more than is the case with most books in the Apoc. The following is

#### 5. Some Sources

(1) *The Book of Job*.—Besides belonging to the same general class of literature as Job, such as deals with the problem of suffering, Tob presents us with a man in whose career there are alternations of prosperity and adversity similar to those that meet us in Job. When Anna reproaches her husband for continuing to believe in a religion which fails him at the critical moment (Tob 2 14), we have probably to see a reflection of the similar incident in Job ("renounce God and die" [Job 2 9]).

(2) *The Book of Sirach*.—There are so many parallels between Sir and Tob that some kind of dependence seems quite clear. Take the following as typical: Both lay stress on the efficacy of almsgiving (4 11; 12 9; cf Sir 3 30; 29 12; 40 24). Both teach the same doctrine of Sheol as the abode of feelingless shades to which the good as well as the bad go (3 6 10; 13 2, cf Sir 46 19; 14 16; 17 28). The importance of interring the dead is insisted upon in both books (1 17; 2 3 7; 4 3 f; cf Sir 7 33; 30 18; 38 16). The same moral duties are emphasized: continued attention to God and the life He enjoins (4 5 f. 19; cf Sir 6 37; 8 8-14; 35 10; 37 2); chastity and the duty of marrying within one's own people (4 12 f; 8 6; cf Sir 7 26; 36 24); proper treatment of servants (4 14; cf Sir 7 20 f); the sin of covetousness (5 18 f; cf Sir 5); see more fully *Speaker's Apoc*, I, 161 f.

(3) *The Ahikar legend*.—We now know that the story of Ahikar referred to in 14 10 existed in many forms and among many ancient nations. The substance of the legend is briefly that Ahikar was prime minister in Assyria under Sennacherib. Being childless he adopted a boy Nadan (called "Aman" in 14 10) and spared no expense or pains to establish him well in life. Upon growing up the young man turns out badly and squanders, not only his own money, but that of Ahikar. When rebuked and punished by the latter, he intrigues against his adoptive father and by false letters persuades the king that his minister is a traitor. Ahikar is condemned to death, but the executioner saves the fallen minister's life and conceals him in a cellar

below his (Ahiḳar's) house. In a great crisis which unexpectedly arises the king expresses the wish that he had still with him his old and (as he thought) now executed minister. He is delighted to find after all that he is alive, and he loses no time in restoring him to his lost position, handing over to him Nadan for such punishment as he thinks fit.

There can be no doubt that the "Achiacharus" of Tob (*Ἀχιαχάρως*, *Achiacharos*, 1 21 f; 2 10; 11 18; 14 10), a nephew of Tobit, is the Ahiḳar of the above story. George Hoffmann of Kiel (*Auszüge aus syrischen Akten persischer Märtyrer*) was the first to connect the Ahiḳar legend with the Achiacharus of Tob, though he believed that the story arose in the Middle Ages under the influence of Tob. Modern scholars, however, agree that the story is of heathen origin and of older date than Tob. Rendel Harris published a Syr VS of this legend together with an Intro and tr (Cambridge Press, 1898), but more important are the references to this tale in the papyri found at Elephantine and recently published by Eduard Sachau. *Aram. Papyrus und Ostraka*, (1911, 147 ff). This last proves that the tale is as old as 400 BC at least. For full bibliography on the subject (up to 1909) see Schürer, *GVV*, III, 256 ff. See also *The Story of Ahiḳar from the Syr. Arab. Armenian, Gr. Slavonic VSS* by Conybeare, J. Rendel Harris and A. S. Lewis, 1898, and in particular *Histoire et Sagesse d'Ahiḳar*, par François Nace, 1909.

(4) The occurrence in 14 10 of "Aman" for "Nadan" may show dependence upon Est, in which book Haman, prime minister and favorite of Ahasuerus (Xerxes, 485-464 BC) exhibits treachery comparable with that of Nadan. But Est seems to the present writer to have been written after and not before Tob (see *Century Bible*, "Esther," 299 ff). It is much more likely that a copyist substituted, perhaps unconsciously through mental association, the name Haman for that which stood originally in the text. Marshall (*HDB*, IV, 789) thinks that the author of Tob was acquainted with the Book of Jub, but he really proves no more than that both have many resemblances. In its angelology and demonology the Book of Jub is much more developed and belongs to a later date (about 100 BC; see R. H. Charles, *Book of Jubilees*, lvi ff, lviii ff). But the two writings have naturally much in common because both were written to express the sentiments of strict Jews living in the 2d cent. BC.

This book seems to reflect the Maccabean age, an age in which faithful Jews suffered for their religion. It is probable that Jth and

**6. Date** Tob owe their origin to the same set of circumstances, the persecutions of the Jews by the Syrian party. The book belongs therefore to about 160 BC. The evidence is external and internal.

(1) *External*.—(a) 14 4-9 implies the existence of the Book of Jon and also the completion and recognition of the prophetic Canon (about 200 BC). (b) Since Sir is used as a source, that book must have been written, i.e. Tob belongs to a later date than say 180 BC. (c) The Christian Father Polycarp in 112 AD quotes from Tob, but there is no earlier allusion to the book. The external evidence proves no more than that Tob must have been written after 180 BC and before 112 AD.

(2) *Internal*.—(a) 14 5 f seems to show that Jon was written while the temple of Zerubbabel was in existence, but before this structure had been replaced by the gorgeous temple erected under Herod the Great: i.e. Tob was written before 25 BC. (b) The stress laid upon the burial of the dead suits well the period of the Syrian persecution, when we know Antiochus Epiphanes allowed Jewish corpses to lie about unburied. (c) We have in Tob and Jth the same zeal for the Jewish Law and its observance which in a special degree marked the Maccabean age. Nöldeke and Löhr (Kautzsch, *Apok. des AT*, 136) argue for a date about 175 BC, on the ground that in Tob there is an absence of that fervent zeal for Judaism and that hatred of men and

things non-Jewish which one finds in books written during the Maccabean wars. But we know for certain that when the Maccabean enthusiasm was at its height there existed all degrees of fervor among the Jews, and it would be a strange thing if *all* the literature of the time represented but one phase of the national life.

We have no means of ascertaining who wrote this book, for the ascription of the authorship to Tobit (1 1 ff) is but a literary device. There are, however, data which help in fixing the nationality of the writer and the country in which he lived. That the author was a Jew is admitted by all, for no other than a Jew could have shown such a deep interest in Jewish things and in the fortunes of the Jewish nation. Moreover, the fact that Tobit, though a member of the Northern Kingdom, is represented as worshipping at the Jerus temple and observing the feasts there (1 4-7) makes it probable that the author was a member of the Southern Kingdom wishing to glorify the religion of his country.

That he did not live in Pal is suggested by several considerations: (1) The book describes the varying fortunes of Jews in exile so completely and with such keen sympathy as to suggest that the writer was himself one of them. (2) The affectionate language in which he refers to Jerus and its religious associations (1 4 ff) is such as a member of the Diaspora would use. (3) The author nowhere reveals a close personal knowledge of Pal. That Tobit, the ostensible author (1 1), should be set forth as a native of Galilee (1 1 f) is due to the art of the writer.

Assuming that the book was written in a foreign land, opinions differ as to which. The evidence seems to favor either Persia or Egypt. In favor of Persia is the Pers background of the book. Asmodeus (3 8, 17) is the Pers *Aēšma daeva*. The duty of burying the dead is suggested to the Jewish writer by the Pers (Zoroastrian) habit of exposing dead bodies on the "Tower of Silence" to be eaten by birds. Consanguineous marriages are forbidden in the Pent (see Lev 18 6 ff); but they are favored by Tob 1 9; 3 15; 4 12; 7 4. The latter seems to show that Tobias and Sarah whom he married were first cousins. Marriages between relatives were common among the Iranians and were defended by the magicians as a religious duty. One may say it was allowed in the particular case in question on account of the special circumstances, the fewness of Jews in the parts where the families of Tobit and Raguel lived; cf Nu 36 4 ff for another special case. The fact that a dog is made to accompany Tobias on his journey to Ecbatana (5 17; 11 4) favors a Pers origin, but is so repugnant to Sem ideas that it is omitted from the Heb VSS of this story (see Dog). For an elaborate defence of a Pers origin of Tob see J. H. Moulton, *Expos T*, XI, 157 ff; cf H. Maldwyn Hughes, *The Ethics of Jewish Apocryphal Literature*, 42 ff. The evidence is not decisive; for a knowledge of Iranian modes of thought and expression may be possessed by persons living far away from Iranian territory. And at some points Tob teaches things contrary to Zoroastrianism. Nöldeke and Löhr hold that the book was composed in Egypt, referring to the facts that the demon Asmodeus on being overcome flees to Egypt (8 3) and that there were Jews in Egypt who remained loyal to their ancestral faith and were nevertheless promoted to high places in the state. The knowledge of Mesopotamia shown by the author is so defective (see 4, above) that a Mesopotamian origin for the book cannot be conceived of.

Tobit exists in an unusually large number of MSS and VSS showing that the book was widely read and regarded as important. But what is peculiar in the case of this book is that its contents differ largely—and not seldom in quite essential matters—in the various MSS, texts and tr (see 3, above).

## 8. Versions

Tob has come down to us in the following languages:

(1) *Greek*.—MSS of the Gr text belong to three classes: (a) that found in the uncials BA (which are almost identical) and most Gr MSS; our Eng. and other modern trs are made from this; (b) that of  $\aleph$  which deviates from (a) often in important matters. The old Lat tallies with this very closely; (c) that of Codd. 44, 106 and 107 (adopting the numbers of Holmes and Parsons), which largely coincides with (b). From  $\gamma$  10 onward this text forms the basis of the Syr (Pesh) VS. Opinions differ as to which of these three Gr texts is the oldest. Fritzsche, Nöldeke and Grimm defend the priority of BA. In favor of this are the following: This text exists in the largest number of MSS and trs; it is most frequently quoted by the Fathers and other early writers; it is less diffuse and more spontaneous, showing less editorial manipulation. Ewald, Reusch, Schürer, Nestle and J. Rendel Harris hold that  $\aleph$  represents the oldest Gr text. Schürer (*GJV*<sup>4</sup>, III, 243) gives the principal arguments for this view (cf Fuller, *Speaker's Comm.*, I, 168 f.).  $\aleph$  is much fuller than BA. Condensation (cf BA) is much more likely, Fuller and Schürer say, than expansion ( $\aleph$ ); but this is questioned. In some cases  $\aleph$  preserves an admittedly better text, which is of course true often of the LXX and even the minor VSS as against the MT.

(2) *Latin*.—(a) The Old Lat based on  $\aleph$  found in (a) the editions published in 1751 by Sabathier (*Bib. Sac. Lat. VSS Antiq.*); (b) in the *Book of Tob* (A. Neubauer, 1878). This text exists in at least three recensions. (b) The Vulg, which simply reproduces Jerome's careless tr made in a single night; see (3). In Jth and Tob the Vulg is in every respect identical with its tr made by Jerome.

(3) *Aramaic* (a term which strictly embraces Syr).—(a) That from which Jerome's Jewish help made the Heb that formed the basis of Jerome's Lat VS. We have no copy of this (see next section). (b) That published by Neubauer (*Book of Tob, a Chaldee Text*) which was found by him imbedded in a Jewish Midr of the 15th cent. Neubauer was convinced and tried to prove that this is the VS which Jerome's teacher put into Heb and which therefore formed the basis of Jerome's own VS. In favor of this is the fact that in chs 1-36, and therefore throughout the book, Tob is spoken of in the third person alike in this Aram. (Chaldee) VS and in Jerome's Lat tr; whereas in all the other VSS (cf chs 1-36) Tob speaks in the first person ("I," etc). But the divergences between this Aram. and Jerome's Lat VSS are numerous and important, and Neubauer's explanations are inadequate (op. cit., vi ff). Besides, Dalman (*Grammatik des jüd.-palest. Aram.*, 1894, 27-29) proves from the language that this VS belongs to the 7th cent. AD or to a later time.

(4) *Syriac*.—The text of this VS was first printed in the *London Polyglot* (vol IV) and in a critically revised form in the *Lib. Apoc. Vet. Test. Syr.* of Lagarde. This text consists of parts of two different VSS. The Hexaplar text based on the usual MSS (BA, etc) is used from 1-9. From  $\gamma$  10 onward the text corresponds closely with the Gr,  $\aleph$ , and  $\beta$  esp. in parts, with the MSS 44, 106, 107. See fully Schürer, *GJV*<sup>4</sup>, 244 ff.

(5) *Hebrew*.—None of the Heb recensions are old. Two Heb texts of Tob have been known since the 16th cent., having been printed then and often afterward. Both are to be found in the *London Polyglot*. (a) That known as *Hebraeus Munsteri* (HM), from the fact that it was published at Basel in 1542 by Sebastian Munster, though it had also been printed in 1516 at Constantinople. (b) That known as *Hebraeus Fagii* (HF), on account of the fact that Paul Fagius published it in 1542. It had, however, been previously published, i.e. in Constantinople in 1517. HF introduces Bib. phraseology wherever possible. Since these are comparatively late trs they have but little critical value, and the same statement applies to the two following Heb trs discovered, edited and trd by Dr. M. Gaster (see *PSBA*, XVIII, 204 ff., 259 ff.; XIX, 27 ff.): (a) A Heb MS found in the British Museum and designated by him HL. This MS agrees with the Vulg and Aram. at some points where the other authorities differ, and Dr. Gaster thinks it not unlikely that in HL we have a copy of the original text. He has not been followed by any scholar in this opinion.

(b) Dr. Gaster copied some years ago from a Heb Midr, apparently no longer existing, a condensed Heb VS (HG) of Tob. Like HL it agrees often with the Vulg and Aram. against other VSS and MSS.

(6) *Ethiopic*.—Dillmann has issued the ancient Ethiopic VSS in his *Biblia Veteris Testamenti Aethiopica*, V, 1894.

The majority of modern scholars, who have a better knowledge of Sem than the older scholars, hold that the original text of Tob was

**9. Original Language** Sem (Aram. or Heb); so Ewald, Hilgenfeld, Graetz, Neubauer, Bickell, Fuller (*Speaker's Apoc*), Marshall (*HDB*). In

favor of this are the following considerations: (1) The existence of an Aram. text in Jerome's day (see [3], above). (2) The proper names in the book, male and female, have a Sem character. (3) The style of

the writer is Sem rather than Aryan, many of the expressions making bad Gr, but when turned into Sem yielding good Aram. or Heb. See the arguments as set out by Fuller (*Speaker's Apoc*, I, 164 ff). Marshall (*HDB*, III, 788) gives his reasons for concluding that the original language was Aram., not Heb, in this opinion following Neubauer (op. cit.). Graetz (*Monatsschrift für Geschichte und Wissenschaft der Juden*, 1879, 386 ff) gives his grounds for deciding for a Heb original. That the book was written in Gr is the view upheld by Fritzsche, Nöldeke, W. R. Smith, Schürer and Löhr. The text of BA, says Löhr, contains Gr of the most idiomatic kind, and gives no suggestion of being a translation.

**LITERATURE**.—Much of the best literature has been cited in the course of the preceding article. See also "Literature" in art. APOCRYPHA, for text, comms., etc, and the Bible Dicts. *EB* (W. Erbt) and *HDB* (J. T. Marshall). Note in addition the following: K. D. Ilgen, *Die Geschichte Tobias, nach den drei verschiedenen Originalen, Griechisch, Lateinisch u. Syr.*, etc, 1800; Ewald, *Gesch.*<sup>3</sup> IV, 269-74; Graetz, *Gesch.*<sup>2</sup> IV, 466 ff; Nöldeke, "Die Texte des Buchs Tob," *Monatsschrift der Berlin Acad.*, 1879, 45 ff; Bickell, "A Source of the Book of Tob," *Athenaeum*, 1890, 700 ff; 1891, 123 ff; I. Abrahams, "Tobit's Dog," *Jewish Quarterly Review*, I, 3, 288; E. Cosquin, "Le livre de Tobie et l'histoire du sage Ahikar," *Rev. Bib. Int.*, VIII, 1899, 50-82, 510-31, rejects R. Harris' views; Margarete Plath, "Zum Buch Tob," *Stud. und Krit.*, 1901, 377-414; I. Levi, "La langue originale de Tob," *Rev. Juive*, XLIV, 1902, 288-91, Oxford Apocrypha, "Tobit" (full bibliography).

T. WITTON DAVIES

**TOCHEN**, tō'ken (תֹּכֵן, *tōkhen*, "task," "measure"; B,  $\Theta\acute{o}\kappa\kappa\alpha$ , *Thōkka*, A,  $\Theta\acute{o}\chi\chi\alpha\nu$ , *Thōchchan*): One of the cities of Simeon, mentioned with Rimmon and Ashan (1 Ch 4 32). The name does not appear in Joshua's list (19 7), but in that place LXX gives Thokka, from which we may infer that the name has fallen out in the Heb. It is not identified.

**TOGARMĀH**, tō-gār'ma (תֹּגַרְמָה, *tōgharmāh*;  $\Theta\omicron\rho\gamma\alpha\mu\acute{\alpha}$ , *Thorgamā*,  $\Theta\epsilon\rho\gamma\alpha\mu\acute{\alpha}$ , *Thergamā*,  $\Theta\upsilon\rho\gamma\alpha\mu\acute{\alpha}$ , *Thurgamā*,  $\Theta\upsilon\rho\gamma\alpha\beta\acute{\alpha}$ , *Thurgabā*; Vulg *Thorgoma*): The 3d son

**1. Its Forms: A** of Gomer, and grandson of Japheth, Identified his brothers being Ashkenaz and Riphath (Gen 10 3). The meaning of the name is doubtful. Grimm (*Gesch. deutsch. Sprache*, II, 325) suggests Sanskr. *toka*, "tribe," and *arma*=Armenia. Etymological and other difficulties stand in the way of Fr. Delitzsch's identification of Togarmah with the Assyri *Til-garimmu*, "hill of Garimmu," or, possibly, "of the bone-heap," a fortress of Melitene, on the borders of Tabal (Tubal).

In Ezk 27 14 Togarmah is mentioned after Tubal, Javan and Mesech as supplying horses and mules to the Tyrians, and in 38 6 it is said

**2. Probably** to have supplied soldiers to the army Armenia or of Gog (Gyges of Lydia). In the **a Tract** Assyri inscriptions horses came from **Connected** Kūsu (neighborhood of Cappadocia), **Therewith** Andia and Mannu, to the N. of Assyria. Both Kiepert and Dillmann regard

Togarmah as having been Southeastern Armenia, and this is at present the general opinion. The ancient identification of their country with Togarmah by the Armenians, though correct, is probably due to the LXX transposition of *g* and *r* (*Thorgamā* for *Togarmah*), which has caused them to see therein the name of Thorgom, father of Haik, the founder of their race (*Moses of Khor*, I, 4, secs. 9-11). Ezk 27 14 (Swete) alone has *g* before *r*:  $\Theta\alpha\gamma\rho\alpha\mu\acute{\alpha}$ , *Thaigramā*. The name "Armenia" dates from the 5th cent. BC. See ARMENIA; TABLE OF NATIONS.

T. G. PINCHES

**TOHU**, tō'hū. See NAHATH.

**TOI**, tō'ī, -i. See TOU.

**TOKEN**, tō'k'n (טוֹקֵן, 'ōth, usually rendered "sign" [on Dt 22 14 ff see the comms.]: "Sign" and "token" are virtually synonymous words and in AV are used with little or no distinction (in Ex 13, of vs 9 and 16). If there is any difference, "token" is perhaps more concrete and palpable than "sign," but this difference cannot be stressed. The modern use of "token," however, as a "memorial of something past" is found in Nu 17 10; Josh 2 12. RV has substituted "sign" in Ex 13 16; Ps 135 9; Isa 44 25, and ARV has "evidence" in Job 21 29 (a needlessly prosaic change). The four NT examples, Mk 14 44; Phil 1 28; 2 Thess 1 5; 3 17 (each for a different Gr word) are self-explanatory. See SIGN.

BURTON SCOTT EASTON

**TOKHATH**, tok'hath. See TIKVAH.

**TOLA**, tō'la (טוֹלָא, 'ōlā', "worm" or "scarlet stuff"):

(1) One of the four sons of Issachar (Gen 46 13; 1 Ch 7 1), mentioned among those who journeyed to Egypt with Jacob (Gen 46 8 f), and in the census taken by Moses and Eleazar, as father of the Tolaites (Nu 26 23) whose descendants in the reign of David included 22,600 "mighty men of valor" (1 Ch 7 2).

(2) One of the Judges, the son of Puah, a man of Issachar. He dwelt in the hill country of Ephraim in the village of Shamir, where after judging Israel 23 years he was buried (Jgs 10 1.2). In the order of succession he is placed between Abimelech and Jair. It is interesting to note that both Tola and Puah are names of colors, and that they occur together both in the case of the judge and in that of the sons of Issachar. They may therefore be looked upon as popular typical or ancestral names of the Issachar tribe, although current critical theories seek an explanation in a confusion of texts.

ELLA DAVIS ISAACS

**TOLAD**, tō'lad. See ELTOLAD.

**TOLAITES**, tō'la-īts. See TOLA.

**TOLBANES**, tol'ba-nēz, tol-bā'nēz (Τολβάνης, *Tolbánēs*): One of the porters who had taken foreign wives (1 Esd 9 25) = "Telem" of Ezr 10 24; perhaps identical with the porter Talmon (Neh 12 25).

**TOLL**, tōl: (1) Aram. מִדְּיָהּ, *middāh*, "toll" or "tribute" paid by a vassal nation to its conqueror (Ezr 4 20; 6 8; Neh 5 4); written also מִנְדְּיָהּ, *mindāh* (Ezr 4 13; 7 24). More accurately for מִלְאָחַ, *hālākh*, "toll," or "way tax" (4 13.20; 7 24). In NT times the Romans had placed throughout Pal many toll stations (τελώνιον, *telōnion*). Levi the publican was stationed at such a tax office (Mt 9 9; Mk 2 14; Lk 5 27); cf τελωνύς, *telōnēs*, a "tax collector" or "publican." The tax which the Jews paid toward the support of the temple, a didrachma, is called τέλος, *tēlos*, "toll" (Mt 17 25), the same as the word rendered "tribute" (Rom 13 7).

EDWARD BAGBY POLLARD

**TOMB**, tōm. See BURIAL.

**TOMORROW**, tōm-mor'ō. See MORROW.

**TONGS**, tongz (מַלְכָּהַיִּים, *melkāhayim*): This word is, where it occurs in AV and ERV, with two exceptions, changed in ARV into "snuffers" (Ex 25 38; Nu 4 9; 2 Ch 4 21; see SNUFFERS). The exceptions are 1 K 7 49, "tongs of gold," and Isa 6 6, "taken with the tongs from off the altar."

In Isa 44 12, where another word (מַלְכָּהַיִּים, *ma'ācādh*) is used, "the smith with the tongs" of AV is changed in RV into "the smith maketh an axe" (cf Jer 10 3). See also ALTAR; TOOLS.

**TONGUE**, tung: Almost invariably for either לָשׁוֹן, *lāshōn*, or γλῶσσα, *glōssa*, the latter word with the cognates ἑτερόγλωσσος, *heterōglōssos*, "of strange tongues" (1 Cor 14 21), γλωσσόδης, *glōssōdēs*, "talkative," EV "full of tongue" (Sir 8 3; 9 18), γλωσσοτομέω, *glōssotomēō*, "to cut out the tongue" (2 Macc 7 4), διγλωσσος, *diglōssos*, "double-tongued" (Sir 5 9; 28 13). In 1 Tim 3 8, however, "double-tongued" is for διλογος, *dilogos*, lit. "two-worded." Where "tongue" in AV translates διάλεκτος, *diālektos* (Acts 1 19; 2 8; 21 40; 22 2; 26 14), RV has "language," while for AV "in the Hebrew tongue" in Jn 5 2; Rev 9 11; 16 16 ('Εβραϊστῆ, *Hebraïstē*) RV has simply "in Hebrew." In addition, in the OT and Apoc, AV uses "to hold one's tongue" as a tr for various verbs meaning "to be silent"; RV in the OT writes "to hold one's peace" and in the Apoc "to be silent," except in Sir 32 8, where AV is retained (σωπάω, *siōpāō*).

The various uses of "tongue" in Eng. are all possible also for *lāshōn* and *glōssa*, whether as the physical organ (Ex 11 7; Mk 7 33, etc) or as meaning "language" (Gen 10 5; Acts 2 4, etc) or as describing anything shaped like a tongue (Isa 11 15; Acts 2 3, etc). In addition, both words, esp. *lāshōn*, appear in a wider range of meanings than can be taken by "tongue" in modern Eng. So the tongue appears as the specific organ of speech, where we should prefer "mouth" or "lips" (Ex 4 10; Ps 71 24; 78 36; Prov 16 1; Phil 2 11, etc), and hence "tongue" is used figuratively for the words uttered (Job 6 30; Ps 139 4; 1 Jn 3 18, etc). So the tongue can be said to have moral qualities (Ps 109 2; Prov 15 4, etc) or to be "glad" (Acts 2 26); to "love with the tongue" (1 Jn 3 18) is to love in word only, and to be "double-tongued" (Sir 5 9; 28 13; 1 Tim 3 8) is to be a liar. A further expansion of this figurative use has produced expressions that sound slightly bizarre in Eng., although their meaning is clear enough: e.g., "Who have whet their tongue like a sword" (Ps 64 3); "His tongue is as a devouring fire" (Isa 30 27); "My tongue is the pen of a ready writer" (Ps 45 1), and, esp., "Their tongue walketh through the earth" (Ps 73 9).

In Job 20 12, "Though wickedness be sweet in his mouth, though he hide it under his tongue," the figure is that of an uncultured man rolling a choice morsel around in his mouth so as to extract the utmost flavor. In Ps 10 7; 66 17 (RVm), however, "under the tongue" means "in readiness to utter," while in Cant 4 11, "Honey and milk are under thy tongue," the pleasure of a caress is described. To "divide their tongue" (Ps 55 9) is to visit on offenders the punishment of Babel. See TONGUES, CONFUSION OF.

BURTON SCOTT EASTON

**TONGUES**, tungz, **CONFUSION OF**: According to Gen 11 1-9, at some time not very long after the Flood, "the whole earth was of 1. The one language and of one speech. And Narrative it came to pass, as they journeyed east" (the "they" is left vague) that they settled in the land of Shinar (Babylonia). There they undertook to build "a city, and a tower, whose top may reach unto heaven," using the Bab burned brick and "slime" as building materials. The motive was to "make us a name; lest we be scattered abroad upon the face of the whole earth." This seems to mean that the buildings would give them a reputation for impregnability that would

secure them against devastating invasions. "And Jeh came down to see." And He said, "Nothing will be withheld from them, which they purpose to do. Come, let us go down, and there confound their language." The persons spoken to are not named (cf Gen 1 26; 3 22), nor is it explained how Jeh, who in ver 5 was on earth, is now in heaven. "So Jeh scattered them abroad from thence," and the name of the city was "called Babel [*bābhel*]; because Jeh did there confound [*bālal*] the language of all the earth: and from thence did Jeh scatter them abroad upon the face of all the earth."

The purpose of this narrative is the explanation of the diversity of human languages. They originated through an act of Jeh, in order to destroy the presumptuous designs of the first builders of Babylon.

The section admittedly belongs to J and it has no connection with the matter (mostly P) in Gen 10. For ch 10 explains the origin of the nations "every one after his tongue, after their families" (vs 5.20.31) as due to the orderly migration and gradual spreading of the sons and descendants of Noah, and names Nimrod (ver 10) as the sole founder of Babylon. Nor does 11 1-9 logically continue the J matter in ch 9, as too many persons are involved for the time immediately following the Flood. Still, it is quite possible that some J matter was dropped when the J and P sources were united at this point. Another possibility is to see in Gen 11 1-9 the continuation of Gen 4 16-24, which it carries on smoothly, with the same distrust of human culture. The murderer Cain went to the E. of Eden (4 16), and his descendants brought in the knowledge of the various arts (4 20-22). These descendants journeyed still farther to the E. (11 2), attempted to use their skill in building the tower and were punished by the *bālal* catastrophe. No account of the Deluge could have followed, for all the diversities of languages would have been wiped away by that event.

This assumption of a special, early source within J probably best explains the facts. It is indicated by the very primitive, naive theology, which is much less developed than that of J as a whole. And the obscure relation of Gen 11 1-9 to the Flood narrative is accounted for, for two narratives were combined here, one of which contained an account of the Deluge, while the other did not.

By using the repeated "going down" of vs 5.7 as a clue, the section can be resolved fairly easily into two narratives, e.g. (1) The men build a tower, "whose top may reach unto heaven," in order to make a name for themselves as marvelous builders. Jeh, seeing the work beginning and "lest nothing be withheld from them," etc, goes down and confounds their language. (2) The men build a city, as a defensive measure, "lest we be scattered abroad on the face of the whole earth." Jeh goes down to see and scatters them abroad. For other analyses see the comms. But they are hardly imperative. For (2) gives no motive for Jeh's action, while "city" and "tower," "confusion of tongues" and "scattering," are complementary rather than parallel terms. The supposition that a few words describing Jeh's return to heaven have disappeared somewhere from ver 6 relieves the awkwardness.

The "historicity" of the narrative will be upheld by very few persons of the present day. Human languages began to diverge (if, indeed there ever was such a thing as a primitive language) tens, if not hundreds, of thousands of years before the building of Babylon and long before human beings had attained enough skill to erect the most rudimentary structures, let alone such an elaborate affair as the brick-built city and tower of Babel. And what is true of languages as a whole is equally true of the languages spoken in the vicinity of Pal. If Egypt, Hittite, and the Sem group have any common point of origin, it lies vastly back of the time and cultural conditions presupposed in Gen 11 1-9. It is needless to enlarge on this, but for the harm done by a persistent clinging to the letter of the narrative, White's *History of the Warfare of Science with Theology* may be consulted. It belonged to the genius of the Hebrews to seek religious explanations of the things around them. And such an explanation of the origin of languages is the content of Gen 11 1-9.

This explanation seems, as yet, to be without parallel, for the tr of the fragmentary British

Museum Inscription K 3657 is entirely uncertain. Indeed, legends as to how the differences of human speech began seem to be extremely scanty everywhere, as if the question were not one that occupied the minds of primitive people. Comparative folklore still has much work to do as regards this special topic (for a few references see *Enc Brit*, 11th ed, art. "Babel," and Gunkel, *Genesis*<sup>3</sup>, in loc.). The other features of the narrative, however, are without great significance. Buildings that were unfinished because the builders offended the gods are fairly abundant, and it is quite possible that the writer of Gen 11 1-9 had some particular Bab structure in mind (see BABEL, TOWER OF). Nor are attempts of men to climb into heaven difficult to conceive, when the sky is thought of (as it nearly always was until comparatively modern times) as a material dome. So Gr Bar (3 6 f) specifies that they "built the tower to the height of 463 cubits. And they took a gimlet, and sought to pierce the heaven, saying, Let us see whether the heaven is made of clay, or of brass, or of iron." Closely parallel to the Babel story is the Gr legend of the giants, who piled Pelion on Ossa in their attempt to storm the dwelling of the gods, and, as a matter of fact, the two accounts seem to be combined in Sib Or 3 97-104.

Whether aided by a tradition about some particular Bab tower or not, the localization of the story in Babylonia was inevitable. The Babylonians, above all nations in the world, relied on their wisdom and their skill, and so nowhere but in Babylon would this supreme presumption have been possible. Babylon, the embodiment of pride, at the very beginning of her existence was guilty of an act of pride so overwhelming as to call out God's vengeance. The "folk-etymology" *bābhel-bālal* (in Aram. *bābhel-balbēl*) may have been suggested by this story, or (perhaps more probably) it may have originated separately, perhaps at first as a piece of deliberate irony. Certainly the many languages that could be heard in Babylon were not without significance for the story.

The religious value of the story is dimmed for the modern reader because of the very primitive concepts that it contains. The men

6. Religious are able to build up into heaven. Value order to see what they are doing Jeh is obliged to "come down." He is obliged to take action lest His dwelling-place be invaded (cf Gen 3 22). And the "let us go down" of ver 7, while certainly not polytheistic, is equally certainly a polytheistic "remnant." On the other hand, it is to be noted that God's power is never in question and that there is no desperate and uncertain battle as in the Gr legend. Important, also (and often overlooked), is the realization that God's power is just as active in Babylon as it is in Pal. The primal meaning to the Israelite, however, was this: In Babylon was seen the greatest enemy of the people of God, possessing immeasurable resources. Humanly speaking, there were no limits to this power, and if it had been uncontrolled at the beginning, all the world would have been overwhelmed with the rule of evil. This God had prevented.

LITERATURE.—Driver in *HDB*; Cheyne (art. "Babel, Tower of") in *EB*; the comms. on Gen, esp. those of Skinner, Driver, Procksch, and Gunkel.

BURTON SCOTT EASTON

TONGUES, GIFT OF: A spiritual gift mentioned in Acts 10 44-46; 11 15; 19 6; Mk 16 17, and described in Acts 2 1-13 and at length in 1 Cor 12-14, esp. ch 14. In fact, 1 Cor 14 contains

such a full and clear account that this passage is basic. The speaker in a tongue addressed God

(vs 2.28) in prayer (ver 14), principally in the prayer of thanksgiving (vs 15-17). The words so uttered of 1 Cor 14 were incomprehensible to the congregation (vs 2.5.9, etc), and even to the speaker himself (ver 14). Edification, indeed, was gained by the speaker (ver 4), but this was the edification of emotional experience only (ver 14). The words were spoken "in the spirit" (ver 2); i.e. the ordinary faculties were suspended and the Divine, specifically Christian, element in the man took control, so that a condition of ecstasy was produced. This immediate (mystical) contact with the Divine enabled the utterance of "mysteries" (ver 2)—things hidden from the ordinary human understanding (see MYSTERY). In order to make the utterances comprehensible to the congregation, the services of an "interpreter" were needed. Such a man was one who had received from God a special gift as extraordinary as the gifts of miracles, healings, or the tongues themselves (12 10.30); i.e. the ability to interpret did not rest at all on natural knowledge, and acquisition of it might be given in answer to prayer (14 13). Those who had this gift were known, and St. Paul allowed the public exercise of "tongues" only when one of the interpreters was present (ver 28). As the presence of an interpreter was determined before anyone spoke, and as there was to be only one interpreter for the "two or three" speakers (ver 28), any interpreter must have been competent to explain any tongue. But different interpreters did not always agree (ver 26), whence the limitation to one.

These characteristics of an interpreter make it clear that "speaking in a tongue" at Corinth was not normally felt to be speaking in a

foreign language. In ver 10 EV is misleading with "there are, it may be, Barred Out so many kinds of voices in the world," which suggests that St. Paul is referring directly to the tongues. But *tosaita* there should be rendered "very many," "ever so many," and the verse is as purely illustrative as is ver 7. Hence foreign languages are to be barred out. (Still, this need not mean that foreign phrases may not occasionally have been employed by the speakers, or that at times individuals may not have made elaborate use of foreign languages. But such cases were not normative at Corinth.) Consequently, if "tongues" means "languages," entirely new languages must be thought of. Such might have been of many kinds (12 28), have been regarded as a fit creation for the conveyance of new truths, and may even at times have been thought to be celestial languages—the "tongues of angels" (13 1). On the other hand, the word for "tongue" (*glōssa*) is of fairly common use in Gr to designate obsolete or incomprehensible words, and, specifically, for the obscure phrases uttered by an oracle. This use is closely parallel to the use in Corinth and may be its source, although then it would be more natural if the "ten thousand words in a tongue" of 14 19 had read "ten thousand *glōssai*." In no case, however, can "tongue" mean simply the physical organ, for 14 18.19 speaks of articulated words and uses the pl. "tongues" for a single speaker (cf vs 5.6).

A complete explanation of the tongues is given by the phenomena of ecstatic utterances, esp. when taken in connection with the history

3. A State of Ecstasy of NT times. In ecstasy the soul feels itself so suffused with the Divine that the man is drawn above all natural modes of perception (the understanding becomes "unfruitful"), and the religious nature alone is felt to be active. Utterances at such times naturally

become altogether abnormal. If the words remain coherent, the speaker may profess to be uttering revelations, or to be the mere organ of the Divine voice. Very frequently, however, what is said is quite incomprehensible, although the speaker seems to be endeavoring to convey something. In a still more extreme case the voice will be inarticulate, uttering only groans or outcries. At the termination of the experience the subject is generally unconscious of all that has transpired.

For the state, cf Philo, *Quis rerum divin.* li-liii.249-66: "The best [ecstasy] of all is a Divinely infused rapture and 'mania,' to which the race of the prophets is subject. . . . The wise man is a sounding instrument of God's voice, being struck and played upon invisibly by Him. . . . As long as our mind still shines [is active] . . . we are not possessed [by God]. . . . hut . . . when the Divine light shines, the human light sets. . . . The prophet . . . is passive, and another [God] makes use of his vocal organs." Cf, further, the descriptions of Celsus (Origen, *Contra Cels.*, vii.9), who describes the Christian "prophets" of his day as preaching as if God or Christ were speaking through them, closing their words with "strange, fanatical, and quite unintelligible words, of which no rational person can find the meaning." The Gr papyri furnish us with an abundance of magical formulae couched in unintelligible terms (e.g. *Pap. Lond.*, 121, "Iao, eloai, marmarachada, menepho, mermai, ieor, aeio, erephia, pherphia," etc), which are not infrequently connected with an ecstatic state (e.g. Reitzenstein, *Poimandres*, 53-58).

Interpretation of the utterances in such a state would always be difficult and diversities of interpretation would be unavoidable. Still, with a fixed content, such as the Christian religion gave, and with the aid of gestures, etc, men who felt that they had an understanding of such conditions could undertake to explain them to the congregation. It is to be noted, however, that St. Paul apparently does not feel that the gift of interpretation is much to be relied on, for otherwise he would have appraised the utility of tongues more highly than he does. But the popularity of tongues in Corinth is easily understood. The speaker was felt to be taken into the closest of unions with God and hence to be an especial object of God's favor. Indeed, the occurrence of the phenomenon in a neo-convert was irrefragable proof that the conversion was approved by God (Acts 10 44-48; 11 15; 19 6). So in Mk 16 17 the gift is treated as an exceptional and miraculous Divine blessing (in this verse "new" is textually uncertain, and the meaning of the word, if read, is uncertain also). Moreover, for the more selfish, the gift was very showy (1 Cor 13 1 suggests that it was vociferous), and its possession gratified any desire for personal prominence.

The account in Acts 2 differs from that of 1 Cor 14 in making the tongues foreign languages, although the ability to use such languages is

4. The Account in Acts 2 not said to have become a permanent apostolic endowment. (Nor is it said that the speech of Acts 2 14-36 was delivered in more than one language.)

When the descent of the Spirit occurred, those who were assembled together were seized with ecstasy and uttered praises to God. A crowd gathered and various persons recognized words and phrases in their own tongues; nothing more than this is said. That the occasion was one where a miracle would have had unusual evidential value is evident, and those who see a pure miracle in the account have ample justification for their position. But no more than a providential control of natural forces need be postulated, for similar phenomena are abundantly evidenced in the history of religious experience. At times of intense emotional stress the memory acquires abnormal power, and persons may repeat words and even long passages in a foreign language, although they may have heard them only once. Now the situation at Jerus at the time of the Feast gave exactly the conditions needed, for then there were gathered pilgrims from all countries, who recited in public liturgical passages (esp. the *Sh'mōneh 'Esreh*) in their own languages. These, in part, the apostles and the "brethren" simply reproduced. Incomprehensible words and phrases may well have been included also (Acts 2 13), but for the dignity of the apostles and for the importance of Pentecost St. Luke naturally cared to em-



phasize only the more unusual side and that with the greatest evidential value. It is urged, to be sure, that this interpretation contradicts the account in 1 Cor 14. But it does so only on the assumption that the tongues were always uniform in their manifestation and appraisal everywhere—and the statement of this assumption is its own refutation. If the modern history of ecstatic utterances has any bearing on the Apostolic age, the speaking in foreign languages could not have been limited only to Pentecost. (That, however, it was as common as the speaking in new "languages" would be altogether unlikely.) But both varieties St. Luke may well have known in his own experience.

St. Paul's treatment of the tongues in 1 Cor 12-14 is a classical passage for the evaluation of religious emotionalism. Tongues are a

**5. Religious Divine gift, the exercise is not to be Emotion- forbidden (14 39), and St. Paul himself is grateful that he has the gift in an uncommon degree (14 18). Indeed, to those who treat them simply with scorn they become a "sign" that hardening is taking place (14 21-23). Yet a love of them because they are showy is simply childish (14 20; 13 11), and the possessor of the gift is not to think that he has the only thing worth obtaining (ch 12). The only gift that is utterly indispensable is love (ch 13), and without it tongues are mere noise (13 1). The public evidential value of tongues, on which perhaps the Corinthians were inclined to lay stress, St. Paul rates very low (14 21-23). Indeed, when exercised in public they tend to promote only the self-glorification of the speaker (14 4), and so are forbidden when there is not an interpreter, and they are limited for public use at all times (14 27, 28). But the ideal place for their exercise is in private: "Let him speak to himself, and to God" (14 28). The applicability of all this to modern conditions needs no commentary. Ultra-emotionalistic outbreaks still cause the formation of eccentric sects among us, and every evangelist knows well-meaning but slightly weak individuals who make themselves a nuisance. On the other hand, a purely intellectual and ethical religion is rather a dreary thing. A man who has never allowed his religious emotions to carry him away may well be in a high state of grace—but he has missed something, and something of very great value. See also SPIRITUAL GIFTS; TONGUES OF FIRE.**

**LITERATURE.**—Plumptre in *DB* is still useful. Wright, *Some NT Problems* (1898), and Walker, *The Gift of Tongues and Other Essays* (1906), have collections of material. Of the comments on 1 Cor those of Heinrici (latest ed. 1896), Lietzmann (1907) and J. Weiss (1910) are much the best, far surpassing Robertson and Plummer in *ICC* (1911). For the Gr material, see *εσρααίς* in the index of Rhode's *Psyche*. Gunkel, *Die Wirkungen des heiligen Geistes* (1888, 2d reprint in 1909), was epoch-making. For the later period, see Weinel, *Die Wirkungen des Geistes und der Geister* (1899); Lake, *The Earlier Epistles of St. Paul* (London, 1911); and see Inge in *The Quarterly Review* (London, 1914).

BURTON SCOTT EASTON

**TONGUES, INTERPRETATION,** in-tûr-prê-tâ'shun, OF. See SPIRITUAL GIFTS; TONGUES, GIFT OF.

**TONGUES OF FIRE** (γλώσσαι ὡσεὶ πυρός, *glôssai hôsei purós*): The reference in this topic is to the marvelous gift of the Holy Spirit on the Day of Pentecost (Acts 2 1-13). After His resurrection the Lord bade His disciples to tarry in Jerusalem until He should fulfil to them the promise of the Father, and until they should be clothed with power from on high (Lk 24 49). Acts 1 8 repeats the same gracious promise with additional particulars: "But ye shall receive power, when the Holy Spirit is come upon you: and ye shall be my witnesses both in Jerusalem, and in all Judaea and

Samaria, and unto the uttermost part of the earth." These were probably the last words Our Lord spoke on earth before He ascended to the right hand of God.

When the Day of Pentecost was fully come and the disciples, no doubt by previous arrangement and with one accord, were gathered together in one place, the promise was gloriously fulfilled. On that day, the 50th after the Passover, and so the first day of the week, the Lord's day, the Spirit of God descended upon them in marvelous copiousness and power. The gift of the Spirit was accompanied by extraordinary manifestations or phenomena. These were three and were supernatural. His coming first appealed to the ear. The disciples heard a "sound from heaven," which rushed with mighty force into the house and filled it even as the storm rushes, but there was no wind. It was the sound that filled the house, not a wind. It was an invisible cause producing audible effects. Next, the eye was arrested by the appearance of tongues of fire which rested on each of the gathered company. Our AV "cloven tongues" is somewhat misleading, for it is likely to suggest that each fire-like tongue was cloven or forked, as one sometimes sees in the pictures representing the scene. But this is not at all the meaning of Luke's expression; rather, tongues parting asunder, tongues distributed among them, each disciple sharing in the gift equally with the others. "Like as of fire," or, more exactly, "as if of fire," indicates the appearance of the tongues, not that they were actually aflame, but that they prefigured the marvelous gift with which the disciples were now endowed.

Finally, there was the impartation to them of a new strange power to speak in languages they had never learned. It was because they were filled with the Holy Spirit that this extraordinary gift was exhibited by them. Not only did the Spirit enable them thus to speak, but even the utterance of words depended on His Divine influence—they spake "as the Spirit gave them utterance."

Many attempts have been made by writers on the Acts to explain the phenomenon of Pentecost so as to exclude in whole or in part the supernatural element which Luke unquestionably recognizes. Some try to account for the gift of tongues by saying that it was a new style of speaking, or new forms of expression, or new and elevated thoughts, but this is both unnatural and wholly inconsistent with the narrative where a real difference of language is implied. Others imagine that the miracle was wrought upon the ears of the hearers, each of whom supposed what he heard to be uttered in his mother-tongue. But this view contradicts the distinct statement in Acts 2 4: they "began to speak with other tongues," i.e. the disciples did. It contradicts what the multitude affirmed, viz. "How hear we, every man in our own language, wherein we were born?" (ver 8). Furthermore, the view contains an element of falsehood, for in this case the miracle was wrought to make men believe what was not actually the fact. The only reasonable explanation of the phenomena is that which the record bears on its face, and which Luke obviously meant his readers to believe, viz. that the Holy Spirit enabled the disciples to speak in the various languages represented by the multitude gathered together at the time.

The scenes witnessed at Pentecost were somewhat analogous to the events which occurred at the giving of the Law at Sinai, but the contrast between them is much more pronounced. We are told in He 12 18, 19 that "tempest," "fire," and "the voice of words" attended the inauguration of the Mosaic dispensation. Something similar was witnessed at Pentecost. But the differences between the two are very marked. At Sinai there were also the blackness and darkness, the quaking earth, the thunderings and lightnings, the voice of the trumpet exceeding loud, the terror of the people, and the fear of Moses (Ex 19 16-18; He 12 18, 19). Nothing of this was seen at Pentecost.

The phenomena characterize the two dispensations. That of Sinai was legal. Its substance was: Do and live; disobey and die. Law knows no mercy, extends no grace. Exact justice is its rule, perfect righteousness its requirement, and death its penalty. No wonder terrible things accompanied its proclamation, and Moses trembled with fear. No wonder it was called "a fiery law" (Dt 33 2).

With the advent of the Spirit came perfect grace, Divine power and complete pardon for the worst of men. At Sinai God spoke in one language. At Pentecost the Spirit Imparted by through the disciples spoke in many the Spirit tongues (15 in all are mentioned in Acts 2). The Law was for one people alone; the gospel is for the whole race. The sound that accompanied the outpouring of the Spirit filled all the house and all the disciples likewise—token and pledge of the copiousness, the fulness of the gift. The tongues of flame signified the power of speech, boldness of utterance, and persuasiveness which from henceforth were to mark the testimony of the disciples.

The marvelous capabilities which the witnesses display after Pentecost are most noteworthy. It is common to admire their courage and zeal, to contrast their fearlessness in the presence of enemies and danger with their former timidity and cowardice. It is perhaps not so common to recognize in them the qualities that lie at the foundation of all effective work, that which gives to witness-bearing for Christ its real energy and potency. These qualities are such as: knowledge and wisdom, zeal and prudence, confidence and devotion, boldness and love, skill and tact. These and the like gifts appear in their discourses, in their behavior when difficulties arise and dangers impend, and in their conduct before the angry rulers. It is altogether remarkable with what skill and tact they defend themselves before the Sanhedrin, and with what effectiveness they preach the gospel of the grace of God to the multitude, often a scoffing and hostile multitude. In Peter's address on the Day of Pentecost there are the marks of the highest art, the most skilful logic, and the most persuasive argument. Professor Stiffer well says of it: "It is without a peer among the products of uninspired men. And yet it is the work of a Galilean fisherman, without culture or training, and his maiden effort." The like distinguished traits are found in Peter's address recorded in Acts 3, in that to Cornelius and his friends, and in his defence when arraigned by the strict believers at Jerus for having gone into the company of men uncircumcised and having eaten with them. No less must be said of the equally wonderful reply of Stephen to the charge brought against him as recorded in Acts 7. It is quite true that Stephen did not share in the effusion of the Spirit on the Day of Pentecost, so far as we know, but he did share in the gift and power of the Spirit soon after, for we are told that he was full of faith and of the Holy Spirit, that he was also full of grace and power. Accordingly, it should be no surprise to read, as the effect of his discourse, that the high priest and all the rest who heard him "were cut to the heart, and they gnashed on him with their teeth" (ver 54). Stephen spoke with a tongue of fire.

In the management of the serious complaint made by the Grecian Jews against the Hebrews as to the neglect of their widows in the daily ministrations (Acts 6 1), and in their conduct and defence when brought before the council, as they were once and again (chs 4, 5, 12), they exhibited a wisdom and prudence far enough removed from shrewdness and cunning. The qualities they possessed and displayed are uncommon, are more than human, they are the gift of the Holy Spirit with whom they were baptized on Pentecost. So the Lord Jesus had promised (Mk 13 11; Jn 16 13; Acts 1 8).

The tongues of fire which we have been considering appear to have differed in one important aspect from the like gift bestowed on the Corinthians (1 Cor 12, 14). At Pentecost the disciples spoke in the languages of the various persons who heard them; there needed to be no interpreter, as was provided for at Corinth. Paul distinctly orders that if there be no one to explain or interpret the ecstatic utterance of a speaker, he shall keep silent (1 Cor 14 28). At Pentecost many spoke at the same time, for the Spirit had perfect control of the entire company and used each as it pleased Him. At Corinth Paul directed that not more than two or at most three should speak in a tongue, and that by course (one

at a time). At Pentecost each one of the 15 nationalities there represented by the crowd heard in his own tongue wherein he was born the wonderful works of God. At Corinth no one understood the tongue, not even the speaker himself, for it seems to have been a rhapsody, an uncontrolled ecstatic outburst, and in case there was no one to interpret or explain it, the speaker was to hold his peace and speak to himself and to God, i.e. he must not disturb the worship by giving voice to his ecstasy unless the whole assembly should be edified thereby. Paul sets prophecy, or preaching the word of God, far above this gift of tongues.

It may not be out of place here to say that the so-called "gift of tongues," so loudly proclaimed by certain excitable persons in our day, has nothing in common with the mighty action of the Spirit of God on the day of Pentecost, and hardly anything with that which the Corinthian Christians enjoyed, and which Paul regulated with a master-hand. See TONGUES, GIFT OF.

LITERATURE.—Stiffer, *Intro to the Book of Acts*; Alexander, *Comm. on the Acts*; Kuyper, *Work of the Holy Spirit*; Moorehead, *Outline Studies in Acts—Eph.*  
WM. G. MOOREHEAD

**TOOLS**, *toōlz*: In the Bible, references to the handicrafts are almost entirely incidental, and not many tools are named. The following art. aims to give a list of those mentioned, together with those that must have existed also. For detailed description and the Heb and Gr terms employed, see the separate articles.

(1) The percussion tool was the **hammer**, used for splitting or trimming stone, beating metals, and in wood-carving, as well as for driving nails, tent pins, etc. Several words are tr<sup>d</sup> "hammer," but the distinction between them is very vague and in some cases the propriety of the tr is dubious. Certainly no such distinction is made as that between "hammer" and "mallet," nor were separate names given to the different hammers used in the various crafts (cf. e.g., Jgs 4 21; 1 K 6 7; Isa 44 12; Jer 10 4—all for *makkābhāh*). See HAMMER.

(2) Of cutting tools, the simplest was of course the **knife**. In Ex 20 25, however, the knife ("sword," EV "tool") appears as a stone-cutter's implement and is without doubt a chisel. But the hatchet of Ps 74 6 may be a knife. See HATCHET; KNIFE.

For **ax**, again, various words are employed in a way that is quite obscure to us and apparently with meanings that are not fixed. So *garzen* in Dt 20 19 is certainly an ax, but in the Siloam Inscription (ll. 2, 4) it is a pickax (see MATTOCK). The various words tr<sup>d</sup> "ax" (RV "axe") must also somewhere include the word for **adz**, but the specific term, if there were any such (*ma'āqādh*[?]), is unknown. But the **adz** is a very ancient tool and must certainly have existed in Pal. See AX (AXE), AX-HEAD.

The saw was used both for wood and for stone (1 K 7 9), in the latter case being employed in connection with water and sand. But sawing stone was a very laborious process, and this was one reason why the ancients preferred stone in large blocks. These were quarried by the use of heavy hammers and wedges. See SAW.

The plane (*makqō'āh*) of Isa 44 13 should be tr<sup>d</sup> chisel. Chisels, of course, are almost as old as humanity, and were used on both wood and stone and doubtless also on metals. In particular, with a broad chisel and an **adz** the surface of wood may be finished very smoothly, and these two implements took the place of the plane. For wood-carving the concave chisel (**gouge**) may have been invented.

The pencil of Isa 44 13 is probably a stylus, for engraving as well as for marking out lines. For engraving on gems (Ex 28 9, etc.) particularly delicate instruments of this kind must have been used. See LINE; PENCIL.

(3) Among the boring tools, only the awl appears (Ex 21 6; Dt 15 17), an instrument primarily for the use of workers in leather. Holes in wood or stone were made by a drill, often worked with the aid of a drawn bow, through the string of which the drill was passed. See AWL.

(4) Blunted tools were of course sharpened on stones, as everywhere. In 1 S 13 21 EV speaks of sharpening with a file, but the text of the verse is hopelessly corrupt and the tr mere guesswork. But files of some sort (stone?) must of course have been used by metal-workers. See FILE.

(5) Measuring tools were the line and the rod (see REED), and the latter must also have been used as a straight-edge. The compasses of Isa 44 13 were for drawing circles, but doubtless served for measuring also. See COMPASSES. Plumb-line ('*ānākh* in Am 7 7 f, a symbol of the searching moral investigation which would be followed by a precise and exact judgment; cf *mishkōleth*, "plummet," 2 K 21 13; Isa 28 17) and plummet ('*ebhen b'dhūl*, "a stone of tin," Zec 4 10, used by Zerubbabel in testing the completed walls) were likewise necessities and had existed from a very early period. Tools of some sort must have been used in addition by builders in drawing plans, but their nature is unknown. See LINE.

(6) The tools for holding and handling work (vises, tongs, pincers, etc) are never alluded to (AV in Isa 44 12 is wrong; see TONGS). For moving larger objects no use was made of cranes, and lifting was done by the aid of inclined planes and rollers; but blocks of stone weighing hundreds of tons could be handled in this way.

The material of the Heb tools was either iron or bronze. The former was introduced at least by the time of David (2 S 12 31), but the mention of iron as a material is often made in such a way (Am 1 3, etc) as to show that it was not to be taken for granted. In fact, iron was hard to work and expensive, and bronze probably persisted for a while as a cheaper material. Stone tools would be used only by the very poor or as occasional makeshifts or for sacred purposes (Josh 5 2).

For the agricultural tools see AGRICULTURE. See also CARPENTER; CRAFTS; POTTER; SMITH, etc. BURTON SCOTT EASTON

**TOPARCHY**, tō'pār-ki, tō'ār-ki (τοπαρχία, *toparchia*): AV renders this Gr word by "government" in 1 Macc 11 28 (AVm and RV "province"). It denotes a small administrative district corresponding to the modern Turkish *Nahieh*, administered by a *Mudir*. Three such districts were detached from the country of Samaria and added to Judaea. Elsewhere (10 30; 11 34) the word used to describe them is *nómos*. Some idea of the size of these districts may be gathered from the fact that Judaea was divided into ten (Pliny v.14) or eleven (BJ, III, iii, 5) toparchies.

**TOPAZ**, tō'paz. See STONES, PRECIOUS.

**TOPHEL**, tō'fel (טֹפֶל, *tōphēl*; Τόφολ, *Tóphol*): This name is found in a passage with many difficulties (Dt 1 1). The verse ostensibly makes clearer the position occupied by the camp of Israel where Moses addressed the people, by reference to certain other places which might be presumed to be better known. Not one of them, however, has been satisfactorily identified. Some think Tophel may be represented by the modern *et-Tafeleh*, 15 miles S.E. of the Dead Sea, on the caravan road from Petra to Kerak. Apart from the question of position, the change of *t* to *f* is not easily explained. Meantime we must suspend judgment. W. EWING

**TOPHETH**, tō'feth (תּוֹפֶת, *hā-tōpheth*, etymology uncertain; the most probable is its connection with a root meaning "burning"—the "place of burning"; AV Tophet, except in 2 K 23 10): The references are to such a place: "They have built the high places of Topheth, which is in the valley of the son of Hinnom, to burn their sons and their daughters in the fire" (Jer 7 31). On account of this abomination Topheth and the Valley of Hinnom should be called "The valley of Slaughter: for they shall bury in Topheth, till there be no place to bury," RVm "because there shall be no place else" (ver 32); see also Jer 19 6.12.13.14. Josiah is said to have "defiled Topheth" as part of his great religious reforms (2 K 23 10). The site of this shameful place would seem to have been either at the lower end of the VALLEY OF HINNOM (q.v.), near where Akeldama is now pointed out, or in the open ground where this valley joins the Kidron.

E. W. G. MASTERMAN

**TORAH**, tō'rā. See LAW IN THE OT; REVELATION.

**TORCH**, tōrch (דֵּלִיָּה, *lappīdh*; λαμπάς, *lampás*; in AV this word occurs only 4 t [Nah 2 3.4 (Heb 4.5); Zec 12 6; Jn 18 3]. In RV it is found 10 t [Gen 15 17; Jgs 7 16.20; Job 41 19 (Heb 11); Ezk 1 13; Dnl 10 6; Nah 2 4 (Heb 5); Zec 12 6; Jn 18 3; Rev 8 10]: A flambeau; a large portable light. See LAMP; LANTERN.

**TORMAH**, tōr'ma (תּוֹרְמָה, *tormāh*, "fraud"; B, ἐν κρυφῇ, *en kruphē*, "in secret," A, μετὰ δώρων, *metā dōron*, "with gifts"): This name is given in EVm as an alternative to "privily," or "craftily" RV (Jgs 9 31). There is no knowledge of such a place. The text is corrupt.

**TORMENT**, tōr'ment, PLACE OF: A literal tr in Lk 16 28 of τόπος τῆς βασάνου, *tópos tēs basánou*. See HELL.

**TORMENTOR**, tor-men'tér: AV 2 Macc 7 29 for δῆμιος, *dēmios*, "belonging to the people," and so "public executioner," RV "butcher." A term of utter contempt, whose force is lost in AV. Also Mt 18 34 for βασανιστής, *basanistēs*, "torturer." Normally the bankrupt debtor was sold into slavery. But, apparently, in extreme cases (where concealment of assets was suspected?) the defaulter was sent to prison until restitution should be made. Probably the imprisonment itself was regarded as "torment" (as it doubtless was), and the "torturers" need mean nothing more than jailers. BURTON SCOTT EASTON

**TORTOISE**, tōr'tus, tōr'tis, tōr'tois (AV) (צָב, *qābh*, RV "great lizard"; cf Arab. قَبَّ, *qābb*, the thorny-tailed lizard): The word *qābh* occurs as the name of an animal only in Lev 11 29, being the third in the list of unclean "creeping things."

The same word is found in Isa 66 20, trd "litters," and in Nu 7 3, where 'eghlōth *qābh* is trd "covered wagons." Gesenius derives the word, in all senses, from *qābbahh*, "to move gently," "to flow"; cf Arab. *qābbā*, "to flow." The Arab. noun *qābb* is *Uromastix spinipes*, the Arabian thorny-tailed lizard. This lizard is about 18 in. long, its relatively smooth body being terminated with a great tail armed with rings of spiny scales. The Arabs have a familiar proverb, 'a'kad min dhanab ud-qābb, "knottier than the tail of the *qābb*." LXX has for *qābh* in Lev 11 29 ὁ κροκόδειλος ὁ χειραῖος, *ho krokódeilos ho chersaios*, the Eng. equivalent of which, "land-crocodile," is used by RV for the fifth in the list of unclean "creeping things," *kōph*, AV "chameleon."

The writer does not know what can have led the translators of AV to use here the word "tortoise." Assuming that the thorny-tailed lizard is meant,

the "great lizard" of RV may be considered to be a fair translation. See LIZARD.

ALFRED ELY DAY

**TOTEMISM**, tō'tem-iz'm: How far the belief in totems and totemistic relationships existed in early Israel cannot be discussed at length here. Evidence of the belief in deified animal ancestors is supposed by some writers to be found in the tribal names Leah ("wild cow"?), Rachel ("ewe"), Simeon (synonymous with the Arab. *sim'u*, which denotes a cross between a wolf and a hyena), Hamor ("ass"), Caleb ("dog"), Zibiah ("gazelle"), etc. But these names in themselves "do not prove a totem stage in the development of Israel" (HPN, 114); philologically, the view has a shaky foundation (see, e.g. art. "Leah" in 1-vol HDB).

Again, it is true that, as a rule, in totemic communities the individual may not kill or eat the name-giving object of his kin, these animals being regarded as sacred in totem worship and therefore "unclean" (taboo) as food. But the attempt to connect such personal names as Shaphan ("rock-badger"), Achhor ("mouse"), Huldah ("weasel")—all from the time of Josiah (2 K 22 3.12.14; cf Deborah ["bee"], Gaal ["beetle"?], Tola ["crimson worm," "cochineal"], Nahash ["serpent"])—with the list of unclean animals in Lev 11 (see vs 5m.29) and Dt 14 is beset with difficulties (cf, however, Isa 66 17; Ezk 8 10 f), since all the names cannot possibly be explained on this ground. See also SACRIFICE IN THE OT, II, 2, (4); VI, 1.

Robertson Smith (followed by Stade and Benzinger) strongly advocated the view "that clear traces of totemism can be found in early Israel" (see HDB, III, 100). G. B. Gray also seems inclined to favor the view that some of these names may be "indirectly derivative from a totem stage of society" (HDB, III, 483 f), while at the same time he recognizes that "the only question is whether other explanations are not equally satisfactory" (HPN, 105).

Other writers, such as Wellhausen, Nöldeke (ZDMG, 157 f, 1886), Marti (Gesch. der israelit. Religion, 4th ed, 24), Addis (Heb. Rel., 33 f), have opposed or abandoned the theory as applied to Israel.

"Upon the whole we must conclude once more that, while it is certainly possible that Totemism once prevailed in Israel, its prevalence cannot be proved; and, above all, we must hold that the religion of Israel as it presents itself in the OT has not retained the very slightest recollection of such a state of things" (Kautzsch, HDB, extra vol, 614 f; cf p. 623).

The theory is also opposed by Jos. Jacobs (art. "Are there Totem-Clans in the Old Testament?" in Archaeol. Review, III [1889], no. 3, 145 ff); F. V. Zapletal, Der Totemismus u. die Religion Israels; and S. A. Cook, in JQR, XIV, no. 55.

The evidence on either side is inconclusive, but the weight of authority is opposed to the view that totemism ever existed in Israel. What is certain is that totemism was never a potent factor, either in the early religion of Israel as an organized people, or in any of the dominant cults of the historical period as a whole (see arts. "Family" in HDB, I, 850 [Bennett]; "Sacrifice," HDB, IV, 331 [Pater-son], and DEFILEMENT [Crannell], IMAGES, 3, 6 [Cobern], and ISRAEL, RELIGION OF, II, 1, (4) [Orelli], in this Encyclopaedia).

LITERATURE.—In addition to the works cited in the text, see, for the theory of the prevalence of totemism in early Israel, W. R. Smith, Religion of the Semites (2d ed, 1894), Kinship and Marriage in Early Arabia (1903); A. F. Scott, Offering and Sacrifice (1900); and I. Benzinger, Hebräische Archäol. (1907); against, Enc Brit, 11th ed, XIII, 177, art. "Hebrew Religion" (White-house); Standard BD, 782; Temple DB, art. "Shaphan." For a general account and discussion of totemism, see Frazer, Totemism and Exogamy (1910) and The Golden Bough (3d ed, 1907-13); Westermarck, History of Human

Marriage (1891); Deans, Tales from the Totems of Hidery (1898); Lang, Myth, Ritual, Religion (new ed, 1899), The Secret of the Totem (1905), and art. "Totemism" in Enc Brit, 11th ed, XXVII, with extensive bibliography; HDB, extra vol, 115; and Cymru, 1892-93, p. 137; 1893-94, p. 7.

M. O. EVANS

**TOU**, tō'ōō (תוֹ, tō'ū; B, Θῶα, Thōa, A, Θοού, Thooú): King of Hamath. As an enemy of Hadarezer, after David's victory over the latter, he sent David a message of congratulation (1 Ch 18 9 f). In 2 S 8 9 f spelled "Toi."

**TOW**, tō (תֹּוּ, tō'eth [Jgs 16 9; Isa 1 31]): The coarser part of flax, with short threads, used as an example of easily inflammable material. Also Isa 43 17 AV for פִּשְׁתָּהּ, *pishtāh*, the usual word for "flax" (so ERV), here as used for a wick (so ARV, ERVm).

**TOWER**, tou'ēr. See FORTIFICATION, I, 5; CITY, II, 1.

**TOWER OF BABEL**. See ASTRONOMY; BABEL, TOWER OF; TONGUES, CONFUSION OF.

**TOWER OF DAVID** (Cant 4 4). See JERUSALEM.

**TOWER OF EDAR (THE FLOCK)**. See EDER.

**TOWER OF HANANEEL**. See HANANEL.

**TOWER OF IVORY** (מִגְדַּל הַשֵּׁן, *mighdal ha-shēn*): Occurs only in Cant 7 4. Cheyne would, not unreasonably, emend the text and read the "tower of Shenir" as a parallel to the "tower of Lebanon" in the same verse. If the reading "tower of ivory" is correct, the reference must be to some piece of furniture in the adornment of which ivory was much used, and when we compare the word *mighdal* here with its use for a "pulpit" in Neh 8 4, we can think only of a reminiscence of something of the nature of the throne of ivory made by Solomon (1 K 10 18). W. M. CHRISTIE

**TOWER OF LEBANON** (מִגְדַּל הַלְּבָנוֹן, *mighdal ha-l-bhānōn* [Cant 7 4]): The designation "which looketh toward Damascus" compels us to identify it with some portion of, or something in, the eastern range of "Lebanon, toward the sun-rising" (Josh 13 5). It would then of necessity correspond to the chief summit of Hermon, on which there has been from ancient times also a tower-like temple, and from which the view is almost of boundless extent, Damascus with its gardens and groves being surprisingly near and appearing like a beautiful island in a wide extended sea. See LEBANON.

W. M. CHRISTIE

**TOWER OF MEAH**, mē'a. See HAMMEAH.

**TOWER OF PENUEL**. See PENIEL.

**TOWER OF SHECHEM** (מִגְדַּל שֵׁכֶם, *mighdal sh'khem*): Mentioned only in Jgs 9 46-49. It seems along with the Beth-millo and the Beth-elberith to have comprised the three strongest parts of the fortification when Abimelech besieged the town. It was, however, abandoned by its defenders, who took refuge in the Beth-millo, in which they were slain.

**TOWER OF SILOAM**. See SILOAM.

**TOWER OF SYENE**, sī-ē'nē. See SEVENEH.

**TOWER OF THE FURNACES**. See FURNACES, TOWER OF.

**TOWN**, *toun*: This word is used to represent a number of different Heb terms in the OT. (1) When any explanatory word or attendant circumstances show that a "city" was unwalled, and sometimes in the contrary case (1 S 23 7), the Heb 'ir is tr<sup>d</sup> "town" by AV, and RV generally agrees with it (Dt 3 5; 1 S 27 5; Est 9 19). (2) Both AV and RV translate *hawwōth* by "towns" (Nu 32 41; Josh 13 30; 1 K 4 13; 1 Ch 2 23), while *hācērim* and *p'rāzōth* both appear in AV as "towns," but in RV as "villages" (Gen 25 16; Zec 2 4). See HAVVOTH-JAIR. (3) *Bath*, lit. "daughter," is sometimes found in the pl. between the name of a city and *hācērim*, "villages," as in Josh 15 45 m, "Ekron, with its daughters and its villages." "Towns" is evidently the appropriate tr, and, even without *hācērim*, *bath* is rendered "town" (RV Nu 21 25, etc.). The same use of "daughter" occurs also in the Gr of 1 Macc 5 65 (*thugatēr*), AV "town," RV "village," m "daughter." (4) AV and ERV gloss *kīr*, "wall," in Josh 2 15 by rendering it "town wall"; ARV omits. (5) The Gr term *kōmopóleis* (Mk 1 38), being a combination of the words for "village" and "city," is a clear attempt to describe something between the two, and is well tr<sup>d</sup> "town." (6) AV uses "town" (Mt 10 11, etc.) and "village" (Mt 9 35, etc.) quite indifferently for *kōmē*; RV has "village" throughout. For similar changes of AV "town" cf 2 Macc 8 6 (*chōra*); 11 5; 12 21 (*chōrtion*, RV "place"). See CITY; VILLAGE.

W. M. CHRISTIE

**TOWN CLERK**, *klürk*, *klärk* (*γραμματεὺς*, *grammateús*): The word "clerk," "writer," "town clerk," "scribe," is found in this meaning only in Acts 19 35, "when the townclerk had quieted the multitude." Cremer defines the word as signifying a "public servant among the Greeks and the reader of the legal and state-papers" (*Lex. NT*). There was considerable difference between the authority of these "clerks" in the cities of Asia Minor and of Greece. Among the Greeks the *grammateis* were usually slaves, or at least persons belonging to the lower classes of society, and their office was a nominal, almost a mechanical, one. In Asia, on the contrary, they were officers of considerable consequence, as the passage quoted indicates (Thuc. vii.19, "the scribe of the city") and the *grammateis* is not infrequently mentioned in the inscriptions and on the coins of Ephesus (e.g. *Brit. Mus. Inscript.*, III, 2, 482, 528). They had the supervision of the city archives, all official decrees were drawn up by them, and it was their prerogative to read such decrees to the assembled citizens. Their social position was thus one of eminence, and a Gr scribe would have been much amazed at the deference shown to his colleagues in Asia and at the power they wielded in the administration of affairs. See, further, Hermann, *Staats Altertum*, 127, 20; and EPHESUS.

HENRY E. DOSKER

**TRACHONITIS**, *trak-ō-ni'tis*: Appears in Scripture only in the phrase *τῆς Ἰτροπίας καὶ Τραχωνιτιδος χώρας*, *tēs Itouraias kaí Trachōnitidos chōras*, lit. "of the Ituraean and Trachonian region" (Lk 3 1). Trachonitis signifies the land associated with the *trachōn*, "a rugged stony tract." There are two volcanic districts S. and E. of Damascus, to which the Greeks applied this name: that to the N.W. of the mountain of Bashan (*Jebel ed-Drūze*) is now called *el-Lejā'*, "the refuge" or "asylum." It lies in the midst of an arable and pastoral country; and although it could never have supported a large population, it has probably always been inhabited. The other is away to the N.E. of the mountain, and is called in Arab. *eş-Safā*. This covers much the larger area. It is a wild and in-

hospitable desert tract, remote from the dwellings of men. It was well known to the ancients; but there was nothing to attract even a sparse population to its dark and forbidding rocks, burning under the suns of the wilderness. It therefore plays no part in the history. These are the two Trachons of Strabo (xvi.2, 20). They are entirely volcanic in origin, consisting of lava belched forth by volcanoes that have been extinct for ages. In cooling, the lava has split up and crumbled into the most weird and fantastic forms. The average elevation of these districts above the surrounding country is about 30 ft. *Eş-Safā* is quite waterless. There are springs around the border of *el-Lejā'*, but in the interior, water-supply depends entirely upon cisterns. Certain great hollows in the rocks also form natural reservoirs, in which the rain water is preserved through the summer months.

*El-Lejā'* is roughly triangular in shape, with its apex to the N. The sides are about 25 miles in length, and the base about 20. The present writer has described this region as he saw it during two somewhat lengthened visits: "From *Zor'a* our course lay N.E. by E. . . . What a wild solitude it is! Far on every hand stretched a veritable land of stone. The first hour or two of our march no living thing was seen. . . . Wherever we looked, before or behind, lay wide fields of volcanic rock, black and repulsive. . . . With here and there a deep circular depression, through which in the dim past red destruction belched forth, now carefully walled round the lip to prevent wandering sheep or goat from falling in by night. The general impression conveyed was as if the dark waters of a great sea, lashed to fury by a storm, had been suddenly petrified. . . . At times we passed over vast sheets of lava which in cooling had cracked in nearly regular lines, and which, broken through in parts, appeared to rest on a stratum of different character, like pieces of cyclopean pavement. Curious rounded rocks were occasionally seen by the wayside, like gigantic black soap bubbles blown up by the subterranean steam and gases of the active volcanic age; often, with the side broken out as if burst by escaping vapor, the mass, having cooled too far to collapse, remained an enduring monument of the force that formed it. Scanty vegetation sprang from the fissures in the rocks, or preserved a precarious existence in the scanty soil sometimes seen in a hollow between opposing slopes. In a dreary waterless land where the cloudless sun, beating down on fiery stones, creates a heat like that of an oven, it were indeed a wonder if anything less hardy than the ubiquitous thistle could long hold up its head. . . . When the traveler has fairly penetrated the rough barriers that surround *el-Lejā'* he finds not a little pleasant land within—fertile soil which, if only freed a little from overlying stones, might support a moderate population. In ancient times it was partly cleared, and the work of the old-world agriculturists remains in gigantic banks of stones built along the edges of the patches they cultivated" (*Arab and Druze at Home*, 30 ff).

In some parts, esp. those occupied by the Druzes, fair crops are grown. Where the Arabs are masters, poverty reigns. They also have an evil reputation. As one said to the present writer, "They will even slay the guest." '*Arab el-Lejā' anjas ma yakūn* is a common saying, which may be freely rendered: "Than the Arabs of *el-Lejā'* greater rascals do not exist." Until comparatively recent years there were great breadths of oak and terebinth. These have disappeared, largely owing to the enterprise of the charcoal burners. The region to the N.E. was described by a native as *bass wa'r*, "nothing but barren rocky tracts" (cf Heb *ya'ar*), over which in summer, he said, not even a bird would fly. There are many ruined sites. A list of 71 names collected by the present writer will be found in *PEFS*, 1895, 366 ff. In many cases the houses, strongly built of stone, are still practically complete, after centuries of desertion.

There may possibly be a reference to the Trachons in the OT where Jer speaks of the *hārērīm*, "parched places" (17 6). The cognate *el-Harrah* is the word used by the Arabs for such a burned, rocky area. For the theory that *el-Lejā'* corresponds to the OT "Argob," see ARGOB.

The robbers who infested the place, making use

of the numerous caves, were routed out by Herod the Great (*Ant.*, XV, x, 1 ff; XVI, ix, 1; XVII, ii, 1 f). Trachonitis was included in the tetrarchy of Philip (viii, 1; ix, 4). At his death without heirs it was joined to the province of Syria (XVIII, iv, 6). Caligula gave it to Agrippa I. After his death in 44 AD, and during the minority of his son, it was administered by Rom officers. From 53 till 100 AD it was ruled by Agrippa II. In 106 AD it was incorporated in the new province of Arabia. Under the Romans the district enjoyed a period of great prosperity, to which the Gr inscriptions amply testify. To this time belong practically all the remains to be seen today. The theaters, temples, public buildings and great roads speak of a high civilization. That Christianity also made its way into these fastnesses is vouched for by the ruins of churches. Evil days came with the advent of the Moslems. Small Christian communities are still found at *Khabab* on the western *Luhf*, and at *Sūr* in the interior. The southeastern district, with the chief town of *Damet el-'Abia*, is in the hands of the Druzes; the rest is dominated by the Arabs.

W. EWING

### TRADE, trad:

- I. GENERAL
  1. Terms
  2. Position of Palestine
  3. Trade Products of Palestine
  4. Palestinian Traders
- II. HISTORY
  1. To David
  2. Solomon
  3. Maritime Trade
  4. To the Exile
  5. The Exile and After

#### LITERATURE

**I. General.**—For a full list of the commercial terms used in the OT, reference must be made to *EB*, IV, cols. 5193-99. Only the more important can be given here.

For "merchant" the Heb uses almost always one of the two participial forms סוֹחֵר, *soḥēr*, or רוֹכֵל, *rōkḥēl*, both of which mean simply "one who travels." There is no difference in their meaning, but when the two are used together (*Ezk* 27 13 ff) RV distinguishes by using "trafficker" for *rōkḥēl*. The vb. *soḥar*, from which *soḥēr* is derived, is trd "to trade" in *Gen* 34 10.21 and "to traffic" in *Gen* 42 34, with numerous noun formations from the same stem. The vb. *rākhal* from which *rōkḥēl* is derived does not occur, but the noun formation *rōkḥullāh* in *Ezk* 26 12 (RV "merchandise"); 28 5.16. 18 (RV "traffic") may be noted. In *Ezk* 27 24 RV has "merchandise" for *markōleth*, but the word means "place of merchandise," "market." The participle תֹּרְיִם, *tōrim*, from *tūr*, "seek out," in combination with *an'shē*, "men," in 1 K 10 15, is trd "merchant men" by AV, "chapmen" by ERV and "traders" by ARV; in 2 Ch 9 14, AV and ERV have "chapmen" and ARV "traders." The text of these verses is suspected. In *Ezk* 27 (only) "merchandise" represents מַעְדָּרִים, *ma'ārābīm*, from *ārabbh*, "to exchange," trd "to deal," m "exchange," in ver 9 ARV, with "dealers," m "ex-changers," in ver 27 (AV and ERV have "occupy," "occupiers"). כְּנַעֲנִי, *kēna'an*, and כְּנַעֲנִי, *kēna'dni*, "Canaanite," are sometimes used in the sense of "merchant," but it is often difficult to determine whether the literal or the transferred force is intended. Hence all the confusion in EV; in RV note "merchant," *Job* 41 6; "merchant," m "Canaanite," *Prov* 31 24; "trafficker," *Isa* 23 8; "trafficker," m "Canaanite," *Hos* 12 7; "Canaan," m "merchant people," *Isa* 23 11; *Zeph* 1 11, and cf "land of traffic," m "land of Canaan," *Ezk* 17 4. See CHAPMAN; OCCUPY.

In Apoc and NT "merchant" is for ἔμπορος, *ēmporos* (*Sir* 26 29, etc.; *Mt* 13 45; *Rev* 18 3.11.15.23). So "merchandise" is ἐμπορίων, *ēmpōrion*, in *Jn* 2 16 and ἐμπορία, *ēmporia*, in *Mt* 22 5, while ἐμπορεύομαι, *ēmporeuomai*, is trd "make merchandise of" in 2 Pet 2 3 and "trade" in *Jas* 4 13 (AV "buy and sell"). But "to trade" in *Mt* 25 16 is for ἐργάζομαι, *ergázomai* (cf *Rev* 18 17), and *Lk* 19 13 for πράγματερεύομαι, *pragmateuomai*, AV "occupy"; while "merchandise" in *Rev* 18 11.12 is for γόμος, *gōmos*, "cargo" (so RVm; cf *Acts* 21 3). Worthy of note, moreover, is μεταβολία, *metabolía*, "exchange" (*Sir* 37 11).

Any road map of the ancient world shows that Pal, despite its lack of harbors, occupied an extremely important position as regards the 2. Position trade-routes. There was no exit to of Palestine the W. from the great caravan center

Damascus, there was virtually no exit landward from the great maritime centers Tyre and Sidon, and there was no exit to the N. and N.E. from Egypt without crossing Pal. In particular, the only good road connecting Tyre (and Sidon) with Damascus lay directly across Northern Pal, skirting the Sea of Galilee. In consequence, foreign merchants must at all times have been familiar figures in Pal (*Gen* 37 25.28; 1 K 10 15; *Neh* 13 16; *Isa* 2 6; *Zeph* 1 11, etc.). As a corollary, tolls laid on these merchants would always have been a fruitful source of income (1 K 10 15; *Ezk* 26 2; *Ezr* 4 20), and naturally Pal enjoyed particular advantages for the distribution of her own products through the presence of these traders.

Of these products the three great staples were grain, oil and wine (*Hos* 2 8; *Dt* 7 13, etc.). The wine of Pal, however, gained little reputation in the ancient world, and its Products of export is mentioned only in 2 Ch 2 Palestine 10.15; *Ezr* 3 7, while *Ezk* 27 18 says expressly that for good wine Tyre sent to Damascus. Grain would not be needed by Egypt, but it found a ready market in Phoenicia, both for consumption in the great cities of Tyre and Sidon and for export (1 K 5 11; *Ezr* 3 7; *Ezk* 27 17, etc.). A reverse dependence of Pal on Tyre for food (*Isa* 23 18; cf *Gen* 41 57) could have occurred only under exceptional circumstances. Oil was needed by Egypt as well as by Phoenicia (*Hos* 12 1; *Isa* 57 9), but from Northern Israel was probably shipped into Egypt by way of Phoenicia. *Hos* 2 5.9 mentions wool and flax as products of Israel, but neither could have been important. Flax was a specialty of Egypt (*Isa* 19 9) and is hardly mentioned in the OT, while for wool Israel had to depend largely on Moab (2 K 3 4; *Isa* 16 1). Minor products that were exported were "balm . . . honey, spicery and myrrh, pistachio-nuts and almonds" (*Gen* 43 11 m; see the separate arts., and cf "pannage and . . . balm" in *Ezk* 27 17). These were products of Gilead (*Gen* 37 25). "Oaks of Bashan" had commercial value, but only for use for oars (*Ezk* 27 5), and so in small logs. Pal had to import all heavy timbers (1 K 5 6, etc.). Despite *Dt* 8 9, Pal is deficient in mineral wealth. The value of Pal's manufactured products would depend on the skill of the inhabitants, but for the arts the Hebrews seem to have had no particular aptitude (1 K 5 6; cf 1 S 13 19 ff).

In comparison with the great volume of international trade that was constantly passing across Pal, the above products could have 4. Palestin- had no very great value and the great ian Traders merchants would normally have been foreigners. A wide activity as "middlemen" and agents was, however, open to the inhabitants of Pal, if they cared to use it. Such a profession would demand close contact with the surrounding nations and freedom from religious scruples. The Canaanites evidently excelled in commercial pursuits of this time, so much so that "Canaanite" and "merchant" were convertible terms.

**II. History.**—The Israelites entered Canaan as a nomadic people who had even agriculture yet to learn, and with a religious self-consciousness that restrained them from too close relations with their neighbors. Hence they were debarred from much participation in trade. The legislation of the Pent (in sharp dis-

1. To David

inction from that of CH) shows this non-commercial spirit very clearly, as there are no provisions that relate to merchants beyond such elementary matters as the prohibition of false weights, etc (Dt 25 13; Lev 19 36; CC has not even these rules). In particular, the prohibition of interest (Ex 22 25; Dt 23 19, etc) shows that no native commercial life was contemplated, for, without a credit-system, trade on any extensive scale was impossible. All this was to be left to foreigners (Dt 23 20; cf 15 6; 23 12.44). The Jewish ideal, indeed, was that each household should form a self-sufficient producing unit (Prov 31 10-27), with local or national exchange of those commodities (such as tools and salt) that could not be produced at home. And this ideal seems to have been maintained tolerably well. The most northerly tribes, through their proximity to the Phoenicians, were those first affected by the commercial spirit, and in particular the isolated half-tribe of Dan. In Jgs 5 17 we find them "remaining in ships" at the time of Barak's victory. As their territory had no seacoast, this must mean that they were gaining funds by serving in the ships of Tyre and Sidon. Zebulun and Issachar, likewise, appear in Dt 33 19 as the merchants of Israel, apparently selling their wares chiefly at the time of the great religious assemblages. But the disorders at the time of the Judges were an effectual bar against much commerce. Saul at length succeeded in producing some kind of order, and we hear that he had brought in a prosperity that showed itself in richer garments and golden ornaments for the women (2 S 1 24; see MONEY). David's own establishment of an official shekel (2 S 14 26) is proof that trade was becoming a matter of importance.

Under Solomon, however, Israel's real trade began. The writer of K lays special stress on his imports.

From Tyre came timber (1 K 5 6, 2. Solomon etc) and gold (9 11). From Sheba came gold and spices (10 10, "gave" here, like "presents" elsewhere, is a euphemism). From Ophir and elsewhere came gold, silver, precious stones, almug trees, ivory, apes and peacocks (10 11.22.25). According to MT 10 28 f, horses and chariots were brought from Egypt and re-sold to the N.

But the text here is suspected. Egypt had no reputation as a horse-mart in comparison with Northern Syria and Western Armenia (see ПОАРМАН). So many scholars prefer to read "Musri" (in Northwestern Arabia) for "Egypt" (מִצְרַיִם for מצרים—see the comm., esp. EB, III, cols. 3162-63). Yet the change does not clear up all the difficulties, and Egypt was certainly famous for her chariots. And cf Dt 17 16.

In exchange Solomon exported to Tyre wheat and oil (1 K 5 11; 2 Ch 2 10.15 adds "barley . . . and wine"). What he sent to the other countries is not specified, and, in particular, there is no mention of what he exchanged for gold. 1 K 5 11; 9 11, however, indicate that Hiram was the intermediary for most of this gold traffic, so that at the final settlement of accounts Solomon must have been heavily in Hiram's debt. 1 K 9 11 proves this. Solomon had undertaken a larger task than the resources of Pal could meet, and in payment was obliged to cede Northern Galilee to Hiram. (The writer of 1 K explains that 'the cities were worthless,' while Ch passes over the unedifying incident altogether, if 2 Ch 8 2 is not a reversal of the case.)

Among Solomon's other activities sea-commerce was not forgotten. David's victory over Edom gave access to the Red Sea at Ezion-

**3. Maritime geber,** and this port was utilized by **Trade** Hiram and Solomon in partnership (1 K 9 26 ff), Hiram, apparently, supplying the ships and the sailors (10 11). After Solomon's death, Edom revolted and the way to

the sea was closed (11 14). It was not recovered until the time of Jehoshaphat, and he could do nothing with it, "for the ships were broken at Ezion-geber" (22 48), i.e. in the home harbor. Either they were badly built or incompetently manned. The Hebrews had no skill as sailors. See SHIPS AND BOATS.

After the time of Solomon the commerce established by him of course continued, with fluctuations.

Samaria became so important a city **4. To the** from the trade standpoint that Ben- **Exile** hadad I forced Baasha to assign a street there to the merchants of Damascus, while Ahab succeeded in extracting the reverse privilege from Ben-hadad II (1 K 20 34).

The long and prosperous contemporary reigns of Jeroboam II and Uzziah evidently had great importance for the growth of commerce, and it was the growing luxury of the land under these reigns that called forth the denunciations of Amos, Hosea and Isaiah. Amos complains of the importation of expensive foreign luxuries by the rich (cf Isa 3 18-23), who wasted the natural products of Pal (6 3-6; 3 12.15). Grain, the chief article of value, was extorted from the poor (5 11), and the grain-dealers were notoriously dishonest (8 4-6); 8 6c in EV suggests the sale of adulterated grain. The meaning of the Heb, however, is obscure, but of course adulteration must have existed, and it is doubtless not without significance that the labels on the recently discovered Samaritan jar-fragments emphasize the purity of the contents (*Harvard Theol. Rev.*, 1911, 138-39). The extent of commercialism so overwhelms Hosea that he exclaims 'Ephraim is become a Canaanite!' (12 7m). The most unscrupulous dealing is justified by the plea, "Surely I am become rich" (ver 8). Isaiah is shocked at the intimate contracts made with foreigners, which prove so profitable to the makers, but which bring in idolatry (2 6-8). It was in the time of Isaiah that Assy influence began to make itself felt in Judah, and the setting up in the Temple of a pattern of an Assy altar (2 K 16 10 f) must have been accompanied with an influx of Assy commodities of all descriptions. (Similarly, the religious reaction under Hezekiah would have been accompanied by a boycott on Assy goods.) Data for the following pre-exilic period are scanty, but Ezk 26 2 shows that Jerus retained a position of some commercial importance up to the time of her fall. Of especial interest are Isa 23 and Ezk 26, 27 with their descriptions of the commerce of Tyre. Ezekiel indeed confines himself to description, but Isaiah characterizes the income of all this trade as "the hire of a harlot" (vs 17.18), a phrase that reappears in Rev 18 3.9—a chapter couched in the genuine old prophetic tone and based almost exclusively on Isa and Ezk. But it is important to note that Isaiah realizes (23 18) that all this enterprise is capable of consecration to Jeh and is therefore not wrong in itself.

The deportation into Babylon brought the Jews directly into the midst of a highly developed commercial civilization, and, although we

**5. The Exile** are ignorant of the details, they must **and After** have entered into this life to a very considerable extent. Indeed, it is more than probable that it was here that the famed commercial genius of the Jews made its appearance. Certain it is that exiles acquired great wealth and rose to high position (Zec 6 10 f; Neh 1 11; 5 17, etc), and that when an opportunity to return to Pal was opened, most of the exiles preferred to stay where they were (see EXILE). As a matter of fact, the Palestinian community was beggarly poor for years (Zec 8 10; Hag 1 6; Neh 1 3; Mal 3 10-12, etc) and could not even prevent the sale of its chil-

dren into slavery (Joel 3 6). Such trade as existed was chiefly in the hands of foreigners (Joel 3 17; Zec 14 21), but the repeated crop-failures must have forced many Jews into commerce to keep from starving. The history of the 4th cent. is very obscure, but for the later commercial history of the Jews the foundation of Alexandria (332 BC) was a fact of fundamental importance. For Alexandria rapidly became the commercial center of the world and into it the Jews, attracted by the invitations of the Ptolemies, poured in streams. Alexandria's policy was closely copied by Antioch (on the period see *Ant.*, XII, i, iii; cf ALEXANDRIA; ANTIQCH), and *Ant.*, XII, iv, shows that the ability of the Jews was duly recognized by the Gentiles. But this development was outside Pal. Sir does not count commerce among the list of trades in 38 24-30 (note, however, the increased importance of artisans) and his references to commerce throughout are not esp. characteristic (5 8; 8 13, etc; but see 42 7). But even the trade of Pal must have been increasing steadily. Under the Maccabees Joppa was captured, and the opening of its port for Gr commerce is numbered among Simon's "glories" (1 Macc 14 5). The unification of the trade-world under Rome, of course, gave Pal a share in the benefits. Herod was able to work commercial miracles (*Ant.*, XV, vi, 7; viii, 1; ix, 2; xi, 1; XVI, v, 3, etc), and the Pal of the NT is a commercial rather than an agricultural nation. Christ's parables touch almost every side of commercial life and present even the pearl merchant as a not unfamiliar figure (Mt 13 45). Into the ethics of commerce, however, He entered little. Sharp dealings were everywhere (Mk 12 40; Lk 16 1-12, etc), and the service of Mammon, which had pushed its way even into the temple (Mk 11 15-17 and ||'s), was utterly incompatible with the service of God (Mt 6 19-34, etc). In themselves, however, the things of Caesar and the things of God (Mk 12 17 and ||'s) belong to different spheres, and with financial questions pure and simple He refused to interfere (Lk 12 13 f). For further details and for the (not very elaborate) teaching of the apostles see ETHICS.

LITERATURE.—The appropriate sections in the *HA's* and *Bib.* dict., esp. G. A. Smith's indispensable art. "Trade" in *EB*, IV, cols. 5145-99 (1903); for the later period, *GJV*, II, 67-82 (1907), III, 97-102 (1909). Cf also Herzfeld, *Handelsgeschichte der Juden des Alterthums*<sup>2</sup> (1894).

BURTON SCOTT EASTON

TRADES, trädz. See CRAFTS.

TRADITION, tra-dish'un: The Gr word is *παράδοσις*, *parádosis*, "a giving over," either by word of mouth or in writing; then that which is given over, i.e. tradition, the teaching that is handed down from one to another. The word does not occur in the Heb OT (except in Jer 39 [32] 4; 41 [34] 2, used in another sense), or in LXX or Apoc (except in 2 Esd 7 26, used in a different sense), but is found 13 t in the NT (Mt 15 2.3.6; Mk 7 3.5.8.9.13; 1 Cor 11 2; Gal 1 14; Col 2 8; 2 Thess 2 15; 3 6).

The term in the NT has apparently three meanings. It means, in Jewish theology, the oral teachings of the elders (distinguished an-

1. Meaning estors from Moses on) which were in Jewish reverence by the late Jews equally with the written teachings of the OT, and were regarded by them as equally authoritative on matters of belief and conduct. There seem to be three classes of these oral teachings: (a) some oral laws of Moses (as they supposed) given by the great lawgiver in addition to the written laws; (b) decisions of various judges which became precedents in judicial matters; (c) interpretations of great teachers (rabbis) which came

to be prized with the same reverence as were the OT Scriptures.

It was against the tradition of the elders in this first sense that Jesus spoke so pointedly to the scribes and Pharisees (Mt 15 2 f; Mk 7 3 f). The Pharisees charged Jesus with transgressing "the tradition of the elders." Jesus turned on them with the question, "Why do ye also transgress the commandment of God because of your tradition?" He then shows how their hollow traditionalism has fruited into mere ceremonialism and externalism (washing of hands, vessels, saying "Corban" to a suffering parent, i.e. "My property is devoted to God, and therefore I cannot use it to help you," etc), but He taught that this view of uncleanness was essentially false, since the heart, the seat of the soul, is the source of thought, character and conduct (Mk 7 14 f).

The word is used by Paul when referring to his personal Christian teachings to the churches at Corinth and Thessalonica (1 Cor 11 2. As Used 2; 2 Thess 2 15; 3 6). In this sense in 1 Cor the word in the sing. is better tr<sup>d</sup> and 2 Thess "instruction," signifying the body of teaching delivered by the apostle to the church at Thessalonica (2 Thess 3 6). But Paul in the other two passages uses it in the pl., meaning the separate instructions which he delivered to the churches at Corinth and Thessalonica.

The word is used by Paul in Col 2 8 in a sense apparently different from the two senses above.

He warns his readers against the teachings of the false teachers in Colossae, which are "after the tradition of men."

Olshausen, Lightfoot, Dargan, in their comms. in loc., maintain that the reference is to the Judaistic character of the false teachers. This may be true, and yet we must see that the word "tradition" has a much broader meaning here than in 1 above. Besides, it is not certain that the false teachings at Colossae are essentially Jewish in character. The phrase "tradition of men" seems to emphasize merely the human, not necessarily Jewish, origin of these false teachings.

The vb. *παράδωμι*, *paradōmī*, "to give over," is also used 5 t to express the impartation of Christian instruction: Lk 1 2, where eyewitnesses are said to have handed down the things concerning Jesus; 1 Cor 11 2.23 and 15 3 referring to the apostle's personal teaching; 2 Pet 2 21, to instruction by some Christian teacher (cf 1 Pet 1 18).

LITERATURE.—Broadus, Allen, Meyer, comms. on Mt (15 2 f); Swete, Gould, comms. on Mk (7 3 f); Lightfoot, Meyer, comms. on Gal (1 14); Lightfoot, Olshausen, Dargan (*Am. Comm.*), comms. on Col (2 8); Milligan, comm. on 1 and 2 Thess (2 Thess 2 15 and 3 6); Weber, *Jewish Theology* (Ger., *Allsyn. Theol.*); Pocock, *Porta Mosis*, 350-402; Schürer, *HJP*, II, i, sec. 25; Edersheim, *Life and Times of Jesus the Messiah*, II, ch xxxi; Jos, *Ant.*, XIII, x, 6.

CHARLES B. WILLIAMS

TRAFFIC, traf'ik, TRAFFICKER, traf'ik-ēr

(תַּרְכָּלָה, *k'na'an*, מִשְׁחָר, *mishhār*, סַחַר, *shāhar*, רִכְזָה, *rkullāh*): (1) *K'na'an*="Canaan," and as the Canaanites were celebrated merchants, came to mean "merchant," and so "traffic" (see CANAAN). Ezk 17 4 refers to the great eagle who "cropped off the topmost of the young twigs [of cedar] thereof, and carried it unto a land of traffic; he set it in a city of merchants." (2) *Mishhār* means "trade," and so "traffic"; comes from a root meaning "to travel round," e.g. as a peddler. 1 K 10 15 reads: "Besides that which the traders brought, and the traffic of the merchants." This refers to the income of Solomon. (3) *Shāhar* means "to go about," "occupy with," "trade," "traffic," "merchant," and so the business of the moving merchant or peddler. Joseph



said to his brothers: "So will I deliver you your brother, and ye shall traffic in the land" (Gen 42 34). He evidently meant that they should have license to become, throughout Egypt, traveling traders. (4) *R'kullāh*, from a root meaning "to travel for trading," and so a peddler traffic, as in spices, etc. Ezekiel speaks against the prince of Tyre: "By thy great wisdom and by thy traffic hast thou increased thy riches" (28 5); and against the king of Tyre: "in the unrighteousness of thy traffic," etc. (Ezk 28 18). See MARKET; MERCHANDISE; SHIPS AND BOATS, II, 2, (2); TRADE.

WILLIAM EDWARD RAFFETY

**TRAGACANTH**, trag'a-kanth: For "spicery" in Gen 37 25, RVm gives "gum tragacanth or storax." See SPICE; STORAX.

**TRAIN**, trān (vb. תָּרַן, *hānakh*, "educate" [Prov 22 6], with adj. *hānīkh* [Gen 14 14]): In 1 K 10 2 the Queen of Sheba's "train," the noun is תָּרַן, *hayil*, the usual word for "force," "army." But in Isa 6 1 the "train" (שָׂרָי, *shūl*, "loose hanging garment") is that of God's robe (RVm "skirts").

**TRAIN**, trān, **TRAINED**, trānd: The word is used in two places in both AV and RV, viz. Gen 14 14, where it means "drilled," "prepared for war," and Prov 22 6. "Train up a child" means more than to teach, and includes everything that pertains to the proper development of the child, esp. in its moral and spiritual nature. In this broader sense also RV substitutes "train" for the "teach" of AV in Tit 2 4 (*sōphronizō*).

**TRANCE**, trans (ἐκστασις, *ékstasis*): The condition expressed by this word is a mental state in which the person affected is partially or wholly unconscious of objective sensations, but intensely alive to subjective impressions which, however they may be originated, are felt as if they were revelations from without. They may take the form of visual or auditory sensations or else of impressions of taste, smell, heat or cold, and sometimes these conditions precede epileptic seizures constituting what is named the *aura epileptica*. The word occurs 5 t in AV, twice in the story of Balaam (Nu 24 4,16), twice in the history of Peter (Acts 10 10; 11 5), and once in that of Paul (Acts 22 17). In the Balaam story the word is of the nature of a gloss rather than a tr, as the Heb *nāphal* means simply "to fall down" and is tr<sup>d</sup> accordingly in RV. Here LXX has *en hūpnō*, "in sleep" (see SLEEP, DEEP). In Peter's vision on the housetop at Joppa he saw the sail (*othōnē*) descending from heaven, and heard a voice. Paul's trance was also one of both sight and sound. The vision on the Damascus road (Acts 9 3-9) and that recorded in 2 Cor 12 2-4 were also cases of trance, as were the prophetic ecstasies of Saul, Daniel and Elisha, and the condition of John in which he says that he was "in the Spirit" (Rev 1 10).

The border line between trance and dream is indefinite: the former occurs while one is, in a sense, awake; the latter takes place in the passage from sleep to wakefulness. The dream as well as the vision were supposed of old to be channels of revelation (Job 33 15). In Shakespearean Eng., trance means a dream (*Taming of the Shrew*, I, i, 182), or simply a bewilderment (*Lucrece*, 1595).

In the phenomena of hypnotic suggestion, sometimes affecting a number of persons simultaneously, we have conditions closely allied to trance, and doubtless some of the well-authenticated phantom appearances are similar subjective projections from the mind affecting the visual and auditory centers of the brain.

ALEX. MACALISTER

**TRANSFIGURATION**, trans-fig-ū-rā'shun (μεταμορφόωμαι, *metamorphóomai*, "to be transformed"): Used only with reference to the transfiguration of Christ (Mt 17 2; Mk 9 2) and the change wrought in the Christian personality through fellowship with Christ (Rom 12 2; 2 Cor 3 18).

(1) About midway of His active ministry Jesus, accompanied by Peter, James and John, withdrew to a high mountain apart (probably Mt. Hermon; see next art.) for prayer. While praying Jesus was "transfigured," "his face did shine as the sun," and his garments became glistering, exceeding white, so as no fuller on earth can whiten them." It was night and it was cold. The disciples were drowsy and at first but dimly conscious of the wonder in progress before their eyes. From the brightness came the sound of voices. Jesus was talking with Moses and Elijah, the subject of the discourse, as the disciples probably learned later, being of the decease (exodus) which Jesus was about to accomplish at Jerus. As the disciples came to themselves, the figures of Moses and Elijah seemed to withdraw, whereupon Peter impetuously demanded tents to be set up for Jesus and His heavenly visitants that the stay might be prolonged and, if possible, made permanent. Just then a cloud swept over them, and out of the cloud a voice came, saying, "This is my beloved Son: hear ye him." In awe the disciples prostrated themselves and in silence waited. Suddenly, lifting up their eyes they saw no one, save Jesus only (Mt 17 1-13; Mk 9 2-13; Lk 9 28-36).

Such is the simple record. What is its significance? The Scripture narrative offers no explanation, and indeed the event is afterward referred to only in the most general way by Peter (2 Pet 1 16-18) and, perhaps, by John (Jn 1 14). That it marked a crisis in the career of Jesus there can be no doubt. From this time He walked consciously under the shadow of the cross. A strict silence on the subject was enjoined upon the three witnesses of His transfiguration until after "the Son of man should have risen again from the dead." This means that, as not before, Jesus was made to realize the sacrificial character of His mission; was made to know for a certainty that death, soon and cruel, was to be His portion; was made to know also that His mission as the fulfilment of Law (Moses) and prophecy (Elijah) was not to be frustrated by death. In His heart now would sound forever the Father's approval, "This is my beloved Son, in whom I am well pleased." The scene, therefore, wrought out in Jesus a new fervor, a new boldness, a new confidence of ultimate victory which, as a source of holy joy, enabled Him to endure the cross and to despise the shame (He 12 2). In the disciples the scene must have wrought a new faith in the heaven-sent leadership of Jesus. In the dark days which were soon to come upon them the memory of the brightness of that unforgettable night would be a stay and strength. There might be opposition, but there could be no permanent defeat of one whose work was ratified by Moses, by Elijah, by God Himself. Indeed, was not the presence of Moses and Elijah a pledge of immortality for all? How in the face of such evidence, real to them, however it might be to others, could they ever again doubt the triumph of life and of Him who was the Lord of life? The abiding lesson of the Transfiguration is that of the reality of the unseen world, of its nearness to us, and of the comforting and inspiring fact that "spirit with spirit may meet."

The transfigured appearance of Jesus may have owed something to the moonlight on the snow and to the drowsiness of the disciples; but no one who has ever seen the face of a saint fresh from communion with God, as in the case of Moses (Ex 34 29-35) and of Stephen (Acts 6 15), will have any difficulty in believing that

the figure of Jesus was irradiated with a "light that never was on sea or land." See Comms. and Lives of Christ; also a suggestive treatment in Westcott's *Intro to the Study of the Gospels*.

(2) The transfiguration of Christians is accomplished by the renewing of the mind whereby, in utter abandonment to the will of God, the disciple displays the mind of Christ (Rom 12 2); and by that intimate fellowship with God, through which, as with unveiled face he beholds the glory of the Lord, he is "transformed into the same image from glory to glory, even as from the Lord the Spirit" (2 Cor 3 18).

CHARLES M. STUART

**TRANSFIGURATION**, trans-fig-ū-rā'shun, **MOUNT OF** (referred to as the "holy mount" in 2 Pet 1 18): Records of the Transfiguration are found in Mt 17 1ff; Mk 9 2ff; Lk 9 28 ff. From these narratives we gather that Jesus went with His disciples from Bethsaida to the neighborhood of Caesarea Philippi, where Peter's memorable confession was made. Some six or eight days later Jesus went up into a high mountain to pray, taking with Him Peter, James and John. There He was transfigured before them. Descending the next day, He healed a demoniac boy, and then passed through Galilee to Capernaum.

It is quite evident that the tradition placing the scene on the Mount of Olives must be dismissed. Another tradition, dating from the 4th cent., identifies the mountain with Tabor. In the art. on **TABOR, MOUNT**, reasons are stated for rejecting this tradition. It was indeed possible in the time indicated to travel from Caesarea Philippi to Tabor; but there is nothing to show why this journey should have been undertaken; and, the mountain top being occupied by a town or village, a suitable spot could not easily have been found.

In recent years the opinion has become general that the scene must be placed somewhere on Mt.

**2. Mt. Hermon** Hermon. It is near to Caesarea Philippi. It is the mountain *par excellence* in that district (Lk 9 28). It was easily possible in the time to make the journey to *Ḥasbeiyah* and up the lofty steps. The sacred associations of the mountain might lend it special attractions (Stanley, *S and P*, 399). This is supported by the transient comparison of the celestial splendor with the snow, where alone it could be seen in Pal (ib, 400).

It seems to have been forgotten that Mt. Hermon lay beyond the boundaries of Pal, and that the district round its base was occupied by Gentiles (*HJP*, II, i, 133 f). The sacred associations of the mountain were entirely heathen, and could have lent it no fitness for the purpose of Jesus; *hōs chiōn*, "as snow," in Mk 9 3, does not belong to the original text, and therefore lends no support to the identification. It was evidently in pursuance of His ordinary custom that Jesus "went up into the mountain to pray" (Lk 9 28). This is the only indication of His purpose. It is not suggested that His object was to be transfigured. "As he was praying," the glory came. There is no hint that He had crossed the border of Pal; and it is not easy to see why in the circumstances He should have made this journey and toilsome ascent in heathen territory. Next morning as usual He went down again, and was met by a crowd that was plainly Jewish. The presence of "the scribes" is sufficient proof of this (Mk 9 14). Where was such a crowd to come from in this gentile district? Matthew in effect says that the healing of the demoniac took place in Galilee (Mt 17 22). The case against Mt. Hermon seems not less conclusive than that against Tabor.

The present writer has ventured to suggest an identification which at least avoids the difficulties that beset the above (*Expos T*, XVIII, 333 f).

Among the mountains of Upper Galilee *Jebel Jermuk* is esp. conspicuous, its shapely form rising full 4,000 ft. above the sea. It is the highest mountain in Pal proper, and is quite fitly described as *hupsēlōn* ("high"). It stands to the W. over against the *Ṣafed* uplands, separated from them by



*Ṣafed and Jebel Jermuk.*

a spacious valley, in the bottom of which runs the tremendous gorge, *Wādy Leimūn*. It is by far the most striking feature in all the Galilean landscape. The summit commands a magnificent view, barred only to the S.W. by other mountains of the range. It rises from the midst of a district which then supported a large population of Jews, with such important Jewish centers as *Keḥr Bir'im*, *Gishcala*, *Meirōn*, etc, around its base. Remote and lonely as it is, the summit was just such a place as Jesus might have chosen for prayer. It was comparatively easy to reach, and might be comfortably climbed in the evening. Then on His descent next day the crowd might easily assemble from the country and the villages near by. How long Our Lord stayed near Caesarea Philippi after the conversation recorded in Mt 16 21ff we do not know. From *Baniās* to *Gishcala*, e.g. one could walk on foot without fatigue in a couple of days. If a little time were spent in the Jewish villages passed on the way, the six days, or Luke's "about eight days," are easily accounted for. From this place to Capernaum He would "pass through Galilee" (Mk 9 30).

W. EWING

**TRANSFORM**, trans-fōrm' (Rom 12 2; RV 2 Cor 3 18 for μεταμορφόομαι, *metamorphōomai*, and AV 2 Cor 11 13,14,15 for μετασχηματίζω, *metaschēmatiszō*, RV "fashion"): The comms. often explain the former word as connoting a change of nature, while the latter refers only to the appearance, but this distinction is probably fanciful.

**TRANSGRESSION**, trans-gresh'un: From "transgress," to pass over or beyond; to overpass, as any rule prescribed as the limit of duty; to break or violate, as a law, civil or moral; the act of transgressing; the violation of a law or known principle of rectitude; breach of command; offence; crime; sin. In the OT פֶּשַׁע, *pesha'*, occurs 80 t, rendered in all VSS by "transgression." Its meaning is "rebellion"; see **REBELLION**. The word "rebellion" differs from this word in that it may be in the heart, though no opportunity should be granted for its manifestation: "An evil man seeketh only rebellion" (Prov 17 11). Here the wise man contemplates an evil heart, looking for an excuse or opportunity to rebel.

The NT uses παράβασις, *parábasis*, "trespass": "The law . . . was added because of transgressions" (Gal 3 19); "Where there is no law, neither is there trans-

gression" (Rom 4 15); "for the redemption of the transgressions that were under the first covenant" (He 9 15).

DAVID ROBERTS DUNGAN

**TRANSLATION**, trans-lá'shun: The vb. "translate" is found once in the OT (2 S 3 10 AV, in the sense of "to transfer") and 3 t in the NT (Col 1 13, μεθίστημι, *methístēmi*, where it means "to transfer"; twice in He 11 5, where it has the quasi-technical sense of removing one from the earthly to the heavenly state without the intervening experience of death).

The noun "translation" occurs only in He 11 5, μεράθειος, *metáthesis*, where it refers to the transition, the general nature of which has just been described in connection with the vb. With their customary reserve in regard to such matters, the Scriptures simply record the fact of Enoch's translation without commenting either upon the attendant circumstances, or upon the nature of the change involved in his experience. Doubtless what Paul says in 1 Cor 15 51-52 applied in the case of Enoch and also in that of Elijah (2 K 2 11).

W. M. MCPHEETERS

**TRAP** (מִקְשָׁה, *môkēsh*; θήρα, *thēra*, lit. "hunting," used metaphorically in Pss and Rom as "trap"): Any of the methods for taking birds; see SNARE; NET; GIN, etc. It is probable that a trap was more particularly a hole in the ground covered with twigs, concealed by leaves and baited with food. Such devices were common in taking the largest animals and may have been used with birds also. Trap is mentioned frequently in connection with snare and in such manner as to indicate that they were different devices: "Know for a certainty that Jeh your God will no more drive these nations from out of your sight; but they shall be a snare and a trap unto you" (Josh 23 13). Another such reference will be found in Ps 69 22:

"Let their table before them become a snare;  
And when they are in peace, let it become a trap."

This is quoted in Rom 11 9:

"Let their table be made a snare, and a trap,  
And a stumbling block, and a recompense unto them."

An instance where a trap alone is referred to can be found in Jer 5 26: "They set a trap, they catch men." Isa (42 22) uses this expression, "snared in holes." This might mean that a snare was placed in a hole, or that the hole was the snare to lure bird or animal to its death. The former proposition is sustained by Job, who says, "A noose is hid for him in the ground, and a trap for him in the way" (18 10). This tr appears as if it were reversed and should read, "A trap is hid for him in the ground and a noose in the way."

GENE STRATTON-PORTER

**TRAVAIL**, trav'ál (יָלַד, *yáladh* [Gen 35 16, etc], הָיַל, *hál*, הָיִל *hál* [properly "writhe," Job 15 20, etc]; ὄδω, *ódō* [classical *ódōs*] [Mt 24 8, etc], ὄδωσ, *ódōs* [Sir 19 11, etc; Gal 4 19, etc]): "Travail" and its derivatives are used in the primary sense of the labor of childbirth, descriptive of the actual cases of Rachel (Gen 35 16), Tamar (Gen 38 27), Ichabod's mother (1 S 4 19), and the apocalyptic woman clothed with the sun (Rev 12 2). In the majority of passages, however, "travail" is used figuratively, to express extreme and painful sorrow (9 t in Jer), "as of a woman in travail." It is also employed in the sense of irksome and vexatious business (6 t in Eccl, where it is the rendering of the word *inyān*). In the same book "travail" is used to express the toil of one's daily occupation (4 4.6), where it is the tr of *āmāl*. In three places (Ex 18 8; Nu 20 14; Lam 3 5) where AV has "travel" RV has changed it to "travail," as in these passages the word *tlā'āh* refers to the sense of

weariness and toil, rather than to the idea of journeying (in AV the spellings "travel" and "travail" were used indiscriminately; cf Sir 19 11; 31 5). The sorrows which are the fruits of wickedness are compared to the pain of travail in Job 15 20 (*hāl*) and Ps 7 14 (*hābhal*), the word used here meaning the torture or twisting pains of labor; see also the fanciful employment of "travail" in Sir 19 11.

In the NT the travail of childbirth is used as the figure of the painful and anxious struggle against the evils of the world in the soul's efforts to attain the higher ideals of the Christian life (Jn 16 21 [*tiktō*]; Rom 8 22; Gal 4 27); twice, however, it is the rendering of *móchthos*, the ordinary word for "toil," "hardship" or "distress" (1 Thess 2 9; 2 Thess 3 8). See BIRTH; LABOR.

ALEX. MACALISTER

**TRAVELLER**, trav'el-ēr: Jgs 5 6 for הַלָּךְ נְתִיבָהּ, *hālakh nēthībāh*, "goers on paths"; 2 S 12 4 for הֶלֶכְךָ, *hēlekh*, lit. "a going"; Job 31 32 for אָרַח, *'ārah*, participle of a vb. meaning "to wander"; Sir 26 12; 42 3 for ἡδοιπόρος, *hodoipóros*, "one making a way." See WAYFARING MAN.

**TREAD**, tred. See WINE PRESS.

**TREASON**, trēz'n: The tr of קֶשֶׁר, *kesher*, in EV 1 K 16 20; 2 K 11 14 || 2 Ch 23 13. *Qeshher* (from קָשַׁר, *kāshar*, "to bind") means "a conspiracy" (2 S 15 12; 2 K 12 20, etc), and the tr "treason" is due to AV's love of variety.

**TREASURE**, trezh'ūr, **TREASURER**, trezh'ūr-ēr, **TREASURY**, trezh'ūr-i (אֹצֵרוֹת, *'ōcār*, גִּזְזוֹ, *g'naz*, מִקְשָׁמוֹן, *mîkshamōn*, גִּזְזוֹת, *gēzot*, גַּנְזָאֵךְ, *ganzakh*, הֶסֶן, *hōsen*, מִקְשָׁמוֹן, *mîkshamōn*, מִשְׁכַּנְהָ, *miškānāh*, מִקְשָׁמוֹן, *mîkshamōn*, אֹתְרוֹת, *'āthūdh*, שָׁפָן, *sāphan*; γάλα, *gáza*, θησαυρός, *thēsauros*):

**1. In the OT.**—The Eng. word "treasure" has in the OT at least five somewhat distinct meanings as expressed in the words: "treasure,"

**1. Treasure**—*g'naz* (Aram.) or *gēz* (Heb), usually meaning "the thing stored"; tr<sup>d</sup> "treasures" in Ezr 6 1, but in 5 17 and 7 20 tr<sup>d</sup> "treasure-house": "search made in the king's treasure-house." In Est 3 9; 4 7 the Heb form is tr<sup>d</sup> "treasury," as is *ganzakh* in 1 Ch 28 11.

"Storehouse," not the thing stored but the place of storage; *'ōcār* means depository, cellar, garner, armory, store or treasure-house. In

**2. Storehouse**—several places it ought to be tr<sup>d</sup>. In some of these words. It is the most frequent word for treasure. ERV and ARV both translate in some instances by other words, e.g. 1 K 7 51, "treasures of the house of Jeh," so also 2 Ch 5 1; "treasury" in Neh 7 70. 71, "gave to the treasury a thousand darics of gold"; in Job 38 22, "treasures of the snow" (cf Prov 8 21; Jer 10 13; 51 16; Ezr 2 69).

"Treasure" or something concealed. There are 3 Heb words with this meaning and all in AV tr<sup>d</sup> "treasure." (1) *Maṣmōn*, which lit.

**3. Hidden Riches** means "a secret storehouse" and so a secreted valuable, usually money

buried, and so hidden riches of any kind, hid treasures: "treasure in your sacks" (Gen 43 23); "dig for it more than for hid treasures" (Job 3 21); "search for her as for hid treasures" (Prov 2 4); "We have stores hidden in the field, of wheat," etc (Jer 41 8). (2) *Miksham*, treasure as hidden, used only in Dnl 11 43: "have power over the treasures of gold and silver." (3) *Sāphan*, meaning hidden treasure or valuables concealed: "hidden treasures of the sand" (Dt 33 19).

Perhaps the strength of riches and so treasure, the Heb word being *hōšen*, from a root meaning to hoard or lay up: "In the house of the

4. **Strength** righteous is much treasure" (Prov 15 6); "They take treasure and precious things" (Ezk 22 25).  
"Something prepared," made ready, the Heb word being *āthūdh*, meaning "prepared," "ready," therefore something of value and so  
5. **Some-thing Pre- pared** treasure: "have robbed their treasures," fortifications or other things "made ready" (Isa 10 13).

In the OT the Heb word most often tr<sup>d</sup> "treasure" is *ōcār*. It occurs in the sing. as follows: Dt 28 12; 1 Ch 29 8; Neh 10 38; Ps 17 14; 135 4; Prov 15 16; 21 20; Eccl 2 8; Isa 33 6; Dnl 1 2; Hos 13 15; in the pl.: Dt 32 34; 1 K 14 26; 15 18; 2 K 12 18; 14 14; 16 8; 18 15; 20 13,15; 24 13, etc.

The same word is in AV tr<sup>d</sup> "treasuries" in 1 Ch 9 26; 2 Ch 32 27; Neh 13 12,13; Ps 135 7; and "treasury" in Josh 6 19,24; Jer 38 11.

II. **In the NT.**—There are two words tr<sup>d</sup> "treasure": *Gáza* is of Pers origin, meaning "treasure."

1. **Gaza** Found only once in Acts 8 27 concerning the Ethiopian "who was over all her [Queen Candace's] treasure." In the compound *γαζοφυλάκιον*, *gazophulákion*, "guarding of *gaza*," the same word appears and the compound is tr<sup>d</sup> "treasury" in Mk 12 41,43 || Lk 21 1; Jn 8 20. See TEMPLE; TREASURY (OF TEMPLE).

The word *thēsauros*, means lit. a "deposit," so wealth and treasure. Evidently throughout the NT it has a twofold usage as describ-

2. **Thē- sauros** ing (1) material treasure, either money or other valuable material possession, and (2) spiritual treasure, e.g. "like unto treasure hid in a field" (Mt 13 44); "good treasure of the heart" (Mt 12 35). Other references to material treasure are Mt 6 21; 13 52; Lk 12 21,34, etc. References to spiritual treasure are Mt 19 21; Mk 10 21; Lk 6 45; 12 33; 18 22; pl. Mt 6 20; Col 2 3.

In Mt 27 6 the word for "treasury" is *κορβανás*, *korbanás*; cf RVm and see CORBAN.

Treasurer (צָרָה, *āqar*, צָרָה, *gdhābhār*, צָרָה, *gizbār*, צָרָה, *śākhan*; οἰκονόμος, *oikonomos*): (1) *āqar*, meaning primarily "to store up," and hence one who lays up in store, i.e. a "treasurer": "I made treasurers over the treasures" (Neh 13 13). (2) *Gdhābhār* (Aram.), used only in Dnl 3 2,3: "treasurers," named with judges and counsellors as recognized officials. (3) *Gizbār*, used in Ezr 7 21 (Aram.) and equivalent in Ezr 1 8 (Heb): "treasurers beyond the river" and "Mithredath the treasurer." (4) *Śākhan*, primarily meaning "one who ministers to," and hence a keeper of treasure, treasurer: "Get thee unto this treasurer" (Isa 22 15). Perhaps the idea of steward is here intended. (5) *Oikonomos*, by AV tr<sup>d</sup> "chamberlain," more properly in ARV tr<sup>d</sup> "treasurer": "Erastus the treasurer of the city saluteth you" (Rom 16 23).

WILLIAM EDWARD RAFFETY

**TREASURY**, *trezh'ūr-i* (OF TEMPLE) (צָרָה, *ōcār*, usually; צָרָה, *ganzakh*, 1 Ch 28 11; *γαζοφυλάκιον*, *gazophulákion*, *κορβανás*, *korbanás*):

1. **Origin of the Treasury** The need of a "treasury" in connection with the house of Jeh would early be felt for the reception of the offerings of the people, of tithes, and of the spoils of war dedicated to Jeh. Already in Josh 6 19,24, therefore, we read of a "treasury of the house of Jeh," into which "the silver and gold, and vessels of brass and iron," taken at Jericho, were brought. In the reign of David, and in his plans for the future temple, great prominence is

given to the "treasuries." In 1 Ch 26 20 ff are given the names of those who were over "the treasures of the house of God," and over "the treasures of the dedicated things" ("the spoil won in battles," ver 27), the latter being applied "to repair the house of Jeh."

- In David's plans for Solomon the "treasuries" (*ganzakhīm*) are mentioned with the "porch," "the houses," the "upper rooms," the "inner chambers" of the Temple (1 Ch 28 11); and the same distinction is made of  
2. **The Solomonic Temple** "the treasures [*ōc'arōih*] of the house of God," and "the treasures of the dedicated things" (ver 12). In the accounts of the actual building of the Temple, "treasuries" are not mentioned, but subsequent notices give ample evidence of their existence. In the narratives of the repeated plunderings of the Temple (see TEMPLE), constant allusion is made to the carrying away of "the treasures of the house of Jeh" and "the treasures of the king's house" or palace (1 K 14 26; 15 15,18; 2 K 12 18; 14 14; 16 8; 18 15; 24 13). In the episode of Jehoash's repair of the Temple (2 K 12; 2 Ch 24), we have a refreshing glimpse of the presence and uses of the treasury; but this brighter gleam is soon swallowed up again in darkness. Of the larger store-chambers we get a glance in Jer, where we are told that "the house of the king" was "under the treasury" (38 11), i.e. on a lower level under the south wall.

The Book of Neh introduces us to treasury-chambers in the second temple—now used for the voluntary offerings (tithes) of the people—corn, and wine, and oil (Neh 13 4 ff; cf Mal 3 10). A certain Meshullam had repaired the city wall "over against his chamber" (Neh 3 30), and he, with other Levites, kept "the watch at the storehouses of the gates" (12 25). These gates were probably gates of exit on the southern side, as in the Herodian temple.

In Herod's temple the name "treasury" was specially given to the "court of the women" (see TEMPLE, HEROD'S), where were 13 trumpet-shaped boxes for the recep-

3. **The Second Temple in the NT** tion of the offerings of the worshippers. It was here that Jesus saw the poor widow cast in her two mites (Mk 12 41; Lk 21 1-4), and the court is expressly named the "treasury" in Jn 8 20: "These words spake he in the treasury, as he taught in the temple." It is a legitimate deduction that this court was the ordinary scene of the Lord's ministry when teaching in the temple. See also TREASURE, TREASURER, TREASURY.

W. SHAW CALDECOTT

**TREATY**, tré'ti (בְּרִית, *b'rīth*, קָרָה בְּרִית, *kārath b'rīth*, "make a covenant," "league," "treaty"): Although the Israelites were forbidden to make treaties, or enter into covenant, with the Canaanites because of the risk thereby involved of religious apostasy and moral contamination (Ex 23 32; 34 12; Dt 7 2; Jgs 2 2), they were so situated in the midst of the nations that treaty relations of some sort with their neighbors were from time to time inevitable. After the rise of the monarchy, treaties were common. David and Solomon had friendly relations with Hiram, king of Tyre (1 K 5 15 ff); Asa, to rid himself of the hostile approaches of Baasha, king of Israel, entered into a league with Ben-hadad of Syria, which the prophet Hanani denounced (2 Ch 16 1 ff); Ahab entered into a similar compact with Ben-hadad's son and successor, and set him at liberty when he was his prisoner of war (1 K 20 34); and at a later time Jehoshaphat joined Ahab in an expedition against Ben-hadad II to Ramoth-gilead in which Ahab lost his life (1 K

22). Sometimes with Syria and neighboring states against the terrible Assyrian power, and sometimes with Egypt against Assyria or Babylon, the kings of Israel and Judah entered into treaty to resist their advances and to preserve their own independence (2 K 17 4; Hos 7 11; Isa 30 1). Against such alliances the prophets raised their testimony (Isa 31 1; Jer 27 3 ff). See also WAR, 9; ROME, V, 1.

T. NICOL

TREE, trē. See BOTANY.

**TREE OF LIFE** (עֵץ חַיִּים, 'ēz hayyīm; ξύλον τῆς ζωῆς, *xύlon tēs zōēs*): The expression "tree of life" occurs in four groups or connections: (1) in the story of the Garden of Eden, (2) in the Proverbs of the Wise Men, (3) in the apocryphal writings, and (4) in the Apocalypse of John.

The tree was in the midst of the Garden, and its fruit of such a nature as to produce physical immortality (Gen 2 9; 3 22). After

**1. The Tree of Life in the Garden of Eden** guiltily partaking of the tree of life knowledge of good and evil, and the sinful tendency having thus been im-

planted in their natures, the man and woman are driven forth from the Garden lest they should eat of the tree of life and live forever (3 22). The idea seems to be that, if they should eat of it and become immortalized in their sinful condition, it would be an unspeakable calamity to them and their posterity. For sinful beings to live forever upon earth would be inconceivably disastrous, for the redemption and development of the race would be an impossibility in that condition. Earth would soon have been a hell with sin propagating itself forever. To prevent such a possibility they were driven forth, cherubim were placed at the entrance of the Garden, the flame of a sword revolving every way kept the way of the tree of life, and this prevented the possibility of man possessing a physical immortality. It is implied that they had not yet partaken of this tree and the opportunity is now forever gone. Immortality must be reached in some other way.

The interpretation of the story is a standing problem. Is it mythical, allegorical, or historical? Opinions vary from one of these extremes to the other with all degrees of difference between. In general, interpreters may be divided into three classes:

(1) Many regard the story as a myth, an ancient representation of what men then conceived early man to have been, but with no historical basis behind it. All rationalistic and modern critical scholars are practically agreed on this. Budde in his *Urgeschichte* says there was but one tree, that is the tree of the knowledge of good and evil, and the intimation of a tree of life is an interpolation. Barton has endeavored to show that the tree of life was really the date-palm, and the myth gathered around this tree because of its bisexual nature. He holds that man came to his self-realization through the sexual relation, and therefore the date-palm came to be regarded as the tree of life, and the tree of the knowledge of good and evil. But this difference came in later when the knowledge of its origin became obscured. He calls attention to the fact that the sacred palm is found in the sanctuary of Ea at Eridu. All such interpretations are too obviously based upon a materialistic evolution hypothesis.

(2) There are those who regard the entire story as literal: one tree would actually impart physical immortality, the other the knowledge of evil. But this involves endless difficulties also, requires tremendous differences between the laws of Nature then and now, vast differences in fruits, men and animals, and an equally vast difference in God's dealings with man.

(3) We prefer to regard it as a pictorial-spiritual story, the representing of great spiritual facts and religious history in the form of a picture. This is the usual Bible method. It was constantly employed by the prophets, and Jesus continually "pictured" great spiritual facts by means of material objects. Such were most of His parables.

John's Apocalypse is also a series of pictures representing spiritual and moral history. So the tree of life is a picture of the glorious possibilities which lay before primitive man, and which might have been realized by him had not his sin and sinful condition prevented it. God's intervention was a great mercy to the human race. Immortality in sin is rendered impossible, and this has made possible an immortality through redemption; man at first is pictured as neither mortal nor immortal, but both are possible, as represented by the two trees. He sinned and became mortal, and then immortality was denied him. It has since been made possible in a much higher and more glorious way.

This picture was not lost to Israel. The "tree of life," became a common poetic simile to represent

**2. A Common Poetic Simile** that which may be a source of great blessing. In the Book of Prov the conception deepens from a physical source of a mere physical immortality to a moral and spiritual source of a full

life, mental, moral and spiritual, which will potentially last forever. Life, long life, is here attributed to a certain possession or quality of mind and heart. Wisdom is a source and supply of life to man. This wisdom is essentially of a moral quality, and this moral force brings the whole man into right relations with the source of life. Hence a man truly lives by reason of this relationship (Prov 3 18). The allusion in this verse is doubtless to Gen 2 9; 3 22. An expression very similar is Prov 10 11, where the mouth of the righteous is declared to be a fountain of life. Good words are a power for good, and hence produce good living. Prov 11 30 has a like thought: "The fruit of the righteous is a tree of life," i.e. the good life is a source of good in its influence on others. Prov 13 12 says: "Hope deferred maketh the heart sick; but when the desire cometh, it is a tree of life." The meaning seems to be that the gratification of good and lawful desires produces those pleasures and activities which make up life and its blessings. Prov 15 4 says: "A gentle tongue is a tree of life," i.e. its beneficent influences help others to a better life.

The apocryphal writings contain a few references to the tree of life, but use the phrase in a different sense from that in which it is used in the canonical

**3. The Apocryphal Writings** books: "They shall have the tree of life for an ointment of sweet savour" (2 Esd 2 12). Ecclus 1 20 has only an indirect reference to it. Ethioptic Enoch, in his picture of the Messianic age, uses his imagination very

freely in describing it: "It has a fragrance beyond all fragrances; its leaves and bloom and wood wither not forever; its fruit is beautiful and resembles the date-palm" (24 4). Slavonic Enoch speaks thus: "In the midst there is the tree of life . . . and this tree cannot be described for its excellence and sweet odor" (8 3). 2 Esd describing the future says: "Unto you is paradise opened, the tree of life is planted" (8 52).

The Apocalypse of John refers to the tree of life in three places (Rev 2 7; 22 2,14). These are

**4. The Book of Rev** pictures of the glorious possibilities of life which await the redeemed soul. In Ezekiel's picture of the ideal state and the Messianic age, there flows from the sanctuary of God a life-giving

river having trees upon its banks on either side, yielding fruit every month. The leaf of this tree would not wither, nor its fruit fail, because that which gave moisture to its roots flowed from the sanctuary. This fruit was for food and the leaves for medicine (47 12). Very similar to this and probably an expansion of it is John's picture in Rev: "To him that overcometh, to him will I give to eat of the tree of life, which is in the Paradise of God" (2 7). This means that all the possibilities of a complete and glorious life are open to the one that overcomes, and by overcoming is prepared to become immortal in a vastly higher sense than was

possible to primitive man. In his picture of the New Jerus, the river of water of life has the tree of life on either side (22 2). Its leaf never fades and its monthly fruitage never fails. Food and medicine these are to be to the world, supplied freely to all that all may enjoy the highest possibilities of activity and blessedness which can come to those who are in right relationships with God and Jesus Christ. In 22 14 John pronounces a blessing on those who wash their robes, who lead the clean and pure Christ life, for they thereby have the right and privilege of entering into the gates of the City and partaking of the tree of life. This means not only immortal existence, but such relations with Jesus Christ and the church that each has unrestricted access to all that is good in the universe of God. The limit is his own limited capacity.

JAMES JOSIAH REEVE

**TREES, GOODLY.** See GOODLY TREES.

**TREES, SHADY,** shā'di. See LOTUS TREES.

**TREES, THICK.** See THICK TREES.

**TRENCH,** trench, trench. See SIEGE, (5), (8).

**TRESPASS,** tres'pas: To pass over, to go beyond one's right in place or act; to injure another; to do that which annoys or inconveniences another; any violation of law, civil or moral; it may relate to a person, a community, or the state, or to offences against God. The Heb **עֲשָׂוֹן**, 'āshām ("sin"), is used very frequently in the OT when the trespass is a violation of law of which God is the author. The Gr word is **παράπτωμα**, *paráptōma*.

In the OT an offering was demanded when the offence was against God: a female lamb; in other cases, according to the magnitude of the wrong, a ram or a goat; the offering was to be preceded by a confession by the one committing the trespass. If the trespass was against a human being, the wrongdoer must make it right with the person, and when reconciliation should have been effected, then the offering for sin was to be made. See under SACRIFICE IN THE OT, "Trespass Offering." If a person's property has been injured, then the trespasser shall add a fifth to the value of the property injured and give that to the injured party (Lev 6 5). Zachaeus, wanting to make full restitution, went beyond the demands of the Law (Lk 19 1-9).

The NT teaching on the subject is, first to be reconciled to the brother and then offer, or worship (Mt 5 23,24). In all cases, also, the offended party must forgive if the offender shall say, "I repent" (Mt 6 14; Eph 4 32; Col 3 13). We have been alienated by our trespasses from God (Eph 2 1). It was the Father's good will to reconcile all to Himself through Christ (Col 1 20-22). We must be reconciled to God (2 Cor 5 20,21). This being done, our trespasses shall be forgiven and we shall be justified.

DAVID ROBERTS DUNGAN

**TRESPASS OFFERING.** See SACRIFICE IN THE OT.

**TRIAL,** tri'al. See COURTS, JUDICIAL; SANHEDRIN.

**TRIAL OF JESUS.** See JESUS, ARREST AND TRIAL OF.

**TRIBE,** trib (in the OT always for **מַטֵּה**, *matteh*, 183 t, or **שִׁבְט**, *shēbhet*, 145 t, also spelled **שִׁבְט**, *shebhet*; Aram. **שִׁבְט**, *shēbhat* [Ezr 6 17]): Both words mean "staff," and perhaps "company led by chief with staff" (OHL, 641) is the origin of the meaning

"tribe." In the Apoc and NT always for **φυλή**, *phulē*, from **φύω**, *phūō*, "beget," with **δωδεκάφυλον**, *dōdekáphulon*, "twelve tribes," in Acts 26 7. Of the two Heb words, *shēbhet* appears to be considerably the older, and is used in Ps 74 2; Jer 10 16; 51 19 of the whole people of Israel, and in Nu 4 18; Jgs 20 12 (RVm); 1 S 9 21 (RVm) of subdivisions of a tribe (but the text of most of these six verses is suspicious). Further, in Isa 19 13, *shēbhet* is used of the "tribes" (nomes?) of Egypt and *phulē* in Mt 24 30 of "all the tribes of the earth," but otherwise *shēbhet*, *matteh* and *phulē* refer exclusively to the tribes of Israel. In 2 S 7 7 for *shēbhetē*, "tribes," read *shōphētē*, "judges" (cf RVm).

BURTON SCOTT EASTON

**TRIBULATION,** trib-ū-lā'shun (**צָר**, *zar*, **צָרָה**, *zār*, "staid," "narrow," "pent up"; cf Nu 22 26): Closely pressed, as of seals (Job 41 15[7]); of streams pent up (Isa 59 9m); of strength limited (Prov 24 10, "small"). Hence, figuratively, of straitened circumstances; variously rendered "affliction," "tribulation," "distress" (Dt 4 30; Job 15 24; 30 12; Ps 4 2; 18 7; 32 7; 44 11, etc; 78 42; 102 3; 106 44; 119 143; Isa 26 16; 30 20; Hos 5 15; Ezk 30 16). Frequently the fem. form (**צָרָה**, *zārāh*) is similarly rendered "tribulation" (Jgs 10 14 AV; 1 S 10 19 AV; 26 24); in other places "distress," "affliction" (Gen 42 21; Ps 120 1; Prov 11 8; 2 Ch 20 9; Isa 63 9; Jer 15 11; Jon 2 2; Nah 1 9; Zec 10 11).

The Gr is **θλίψις**, *thlipsis*, a "pressing together" (as of grapes), squeezing or pinching (from vb. **θλίβω**, *thlibō*); used figuratively for "distress," "tribulation"; LXX for *zar* and *zārāh*; Vulg *tribulatio pressura* (from *tribulum*, "a threshing sledge").

The vb. form is rendered "suffer tribulation" (1 Thess 3 4 AV, "suffer affliction" RV); "trouble" (2 Thess 1 6 AV, "afflict" RV; cf 2 Cor 1 6; 4 8; 7 5; 1 Tim 5 10; He 11 37). The noun form is rendered in AV variously as "tribulation," "affliction," "persecution," though more uniformly "tribulation" in RV. The word is used generally of the hardships which Christ's followers would suffer (Mt 13 21; 24 9,21,29; Mk 4 17; 13 19,24; Jn 16 33; 1 Cor 7 28); or which they are now passing through (Rom 5 3; 12 12; 2 Cor 4 17; Phil 4 14); or through which they have already come (Acts 11 19; 2 Cor 2 4; Rev 7 14).

EDWARD BAGBY POLLARD

**TRIBUTE,** trib'ūt (**מַס**, *maš*, "tribute," really meaning "forced laborers," "labor gang" [1 K 4 6; 9 15,21]; also "forced service," "serfdom"; possibly "forced payment" is meant in Est 10 1; the idea contained in the modern word is better given by **מִדְּיָה**, *middāh*, [Ezr 6 8; Neh 5 4]): Words used only of the duty levied for Jeh on acquired spoils are **מֶכֶזֶשׁ**, *mekhezš*, "assessment" (Nu 31 28,37,38,39,40,41), **בְּלִי**, *bēlī*, "excise" (Ezr 4 13,20; Neh 7 24), **מַסָּה**, *massā*, "burden" (2 Ch 17 11), and **עֲנִשׁ**, *ōnesh*, "fine" or "indemnity" (2 K 23 33; cf Prov 19 19). The tr "tribute" for **מִשָּׁטָה**, *miššath*, in Dt 16 10 is wrong (cf RVm). **κῆνος**, *kēnos* (Mt 22 17; Mk 12 14) = "census," while **φόρος**, *phōros* (Lk 20 22; 23 2; Rom 13 6,7), signifies an annual tax on persons, houses, lands, both being direct taxes. The *phōros* were paid by agriculturists, payment being made partly in kind, partly in money, and are contrasted with the *tēlē* of the publicans, while *kēnos* is strictly a poll tax. The amount of tribute required as a poll tax by the Romans was the **διδραχμον**, *dīdrachmon* (Mt 17 24), AV "tribute," RV "half-shekel." The **στατήρ**, *statēr* (ver 27), was a tetradrachm, "one shekel," or pay for two. After the destruction of Jerus, the Jews were re-

quired to pay this poll tax toward the support of the worship of Jupiter Capitolinus. Different kinds of personal taxes were raised by the Romans: (1) an income tax, (2) the poll tax. The latter must be paid by women and slaves as well as by free men, only children and aged people being exempted. The



A Subject People Paying Tribute.

payment exacted began with the 14th year in the case of men and the 12th in the case of women, the obligation remaining in force up to the 65th year in the case of both. For purposes of assessment, each person was permitted to put his own statement on record. After public notice had been given by the government, every citizen was expected to respond without personal visitation by an official (see Lk 2 1 ff). On the basis of the records thus voluntarily made, the tax collectors would enforce the payment of the tribute. See also TAX, TAXING. FRANK E. HIRSCH

**TRIBUTE MONEY** (τὸ νόμισμα τοῦ κήσου, *tò nóμισμα toú kēsou* [Mt 22 19], "the coin used in payment of the imperial taxes"); Lit. "the lawful money of the tax," which, in the case of the poll tax, had to be paid in current coin of the realm (see Mt 17 27).

**TRICLINIUM**, tri-klín'i-um (Lat from Gr τρικλίνιον, *triklinion*, from *tri* and *klínē*, "a couch"): A couch for reclining at meals among the ancient Romans, arranged along three sides of a square, the fourth side being left open for bringing in food or tables, when these were used. In the larger Rom houses the dining-rooms consisted of small alcoves in the atrium arranged to receive triclinia. In early OT times people sat at their meals (Gen 27 19; Jgs 19 6; 1 S 20 5; 1 K 13 20). Reclining was a luxurious habit imported from foreign countries by the degenerate aristocracy in the days of the later prophets (Am 2 8; 6 4). Still, we find it common in NT times (Mt 9 10; 26 7; Mk 6 22,39; 14 3,18; Lk 5 29; 7 36,37; 14 10; 17 7; Jn 12 2; in these passages, though EV reads "sat," the Gr words are *anákeimai*, *sunanákeimai*, *anáptō*, *katákeimai* and *anáklínō*, all indicating "reclining"; cf Jn 13 23; 21 20; here AV translates these words "lean," probably with reference to the Jewish custom of leaning at the Passover feast). In Jn 2 8,9 the ruler or governor of the feast is called *architriklinos*, that is, the master of the triclinium. See MEALS, III. NATHAN ISAACS

**TRIM**: The only non-modern use is in Jer 2 33, "How trimmest thou thy way to seek love!" used for *יָאֲבַח*, *yā'abh*, "to make good," here "to study out," and the whole phrase means "to walk in an artificial manner," "like a courtesan."

**TRINE (TRIUNE) IMMERSION**, trín (trí'ūn) i-mūr'shun:

- I. LINGUISTIC BASIS
  1. Immersion
  2. Triple Action
- II. DOCTRINAL ARGUMENT
- III. HISTORICAL PRACTICE
  1. The Jews
  2. John the Baptist
  3. The *Didache*
  4. Justin Martyr
  5. Tertullian
  6. Eunomius
  7. Greek Church

LITERATURE

**I. Linguistic Basis.**—The meaning of the word βαπτίζω, *baptizō*, is "to dip repeatedly," "to submerge" (Thayer, *Gr Lex. NT*). It is probably the frequentative of βάπτω, *báptō*, "to dip," meaning "to dip repeatedly." The word *baptizō* (and βάπτισμα, *báptisma*) in the NT is "used absolutely, 'to administer the rite of ablution,' 'to baptize'" (ib). It is "an immersion in water, performed as a sign of the removal of sin," etc (ib); "*Baptizō*, to dip in or under water" (Liddell and Scott, *Gr Lex.*).

The threefold immersion is based upon the Trinity into which the believer is to be baptized "into the name of the Father and of the Son and of the Holy Spirit" (*eis τὸ ὄνομα τοῦ πατρὸς καὶ τοῦ υἱοῦ καὶ τοῦ ἁγίου πνεύματος, eis τὸ ὄνομα τοῦ πατρὸς καὶ τοῦ υἱοῦ καὶ τοῦ ἁγίου πνεύματος*, Mt 28 19). (On the genuineness of this passage see Plummer, *Comm. on Mt.*)

**II. Doctrinal Argument.**—Whether Jesus spoke the words of Mt 28 19 as a baptismal formula or not does not affect the question. The passages in Acts, "in the name of Jesus Christ" (2 38; 10 48), and "in the name of the Lord Jesus" (8 16; 19 5), are not baptismal formulae, but mean the confession of Christ with all that Christ stands for, viz. the fulness of God and His salvation. The idea of the Trinity pervades the NT and many of the earliest writings (cf 1 Cor 12 4-6; 2 Cor 13 14; Eph 2 18; 3 14-17; 4 4-6; 2 Thess 2 13-15; Heb 6 4-6; 1 Jn 3 23,24; 4 2; Jude vs 20,21; Rev 1 4,5). "Baptized into Christ" has the same religious content as Mt 28 19. Trine immersion is the symbol of baptism into the Triune God. All believers in the Trinity should see the consistency of this symbol. Baptism is the symbol (1) of a complete cleansing, (2) of death, (3) of burial, (4) of resurrection, and (5) of entering into full union and fellowship with the Triune God as revealed by Christ. Trine immersion is the only symbol that symbolizes all that baptism stands for. Note the words of Sanday on Rom 6 1-14 (comm. on Rom, ICC, 153): "Baptism has a double function: (1) It brings the Christian into personal contact with Christ, so close that it may fitly be described as personal union with Him. (2) It expresses symbolically a series of acts corresponding to the redeeming acts of Christ. Immersion=Death. Submersion=Burial (the ratification of Death). Emergence=Resurrection. All these the Christian has to undergo in a moral and spiritual sense, and by means of his union with Christ." Hence the psychological need of a true symbol, trine immersion, to teach and impress the significance of the new life.

**III. Historical Practice.**—The Jews received proselytes by circumcision, baptism (complete immersion) and sacrifice (Schürer, *HJP*, II, 2, pp. 319 f; Edersheim, *LTJM*, Jews II, 745, and I, 273).

John the Baptist baptized "in the river Jordan" (Mt 3 6) and "in Ænon near to

Salim, because there was much water there" (Jn 3 23). Philip and the eunuch "both went down into the water" and they "came up out of the water." All NT baptisms were by immersion (see also Rom 6 1-11).

**2. John the Baptist**

The *Didache* (100-150 AD) ch vii: "Baptize into the name of the Father and of the Son and of the Holy Spirit in living [running] water. But if they have not living water, baptize into other water; and if thou canst not in cold, in warm" (*βαπτίζετε εἰς τὸ ὄνομα τοῦ πατρὸς καὶ τοῦ υἱοῦ καὶ τοῦ ἁγίου πνεύματος ἐν ὕδατι ζῶντι, βαπτίζετε εἰς τὸ ὄνομα τοῦ πατρὸς καὶ τοῦ υἱοῦ καὶ τοῦ ἁγίου πνεύματος ἐν ὑδάτι ζῶντι*). "But if thou have not either, pour out water thrice [*τρῖς, tris*] upon the head into the name of the Father and Son and Holy Spirit." Here the triple action is maintained throughout, even in clinical baptism, while immersion is the rule.

**3. The Didache**

Justin Martyr (*Ap.*, i.61) describes baptism which can only be understood as triune immersion.

**4. Justin Martyr**

Tertullian (*De Corona*, iii) says, "Hereupon we are thrice immersed" (*dehinc ter mergitmur*). Again (*Ad Praezam*, xxvi), "And lastly he commands them to baptize into the Father and the Son and the Holy Spirit, not into a unipersonal God.

**5. Tertullian**

And indeed it is not only once but three times that we are immersed into the Three Persons, at each several mention of their names" (*nam nec semel, sed ter, ad singula nomina, in personas singulos, tinguimur*). Eunomius (c 360), introduced single immersion "into the death of Christ." This innovation was condemned. Apos Const, 50, says, "If any presbyter or bishop does not perform the one initiation with three immersions, but with giving one immersion only into the death of the Lord, let him be deposed." Single immersion was allowed by Gregory the Great (c 691) to the church in Spain in opposition to the Arians who used a triune (not triune) immersion (*Epis.*, i.43). This was exceptional.

**6. Euno-mius**

The Gr church has always baptized by triune immersion. The historical practice of the Christian church may well be summed up in the words of Dean Stanley: "There can be no question that the original form of baptism—the very meaning of the word—was complete immersion in the deep baptismal waters; and that for at least four centuries, any other form was either unknown, or regarded, unless in the case of dangerous illness, as an exceptional, almost monstrous case. . . . A few drops of water are now the western substitute for the threefold plunge into the rushing river or the wide baptisteries of the East" (*Hist of Eastern Church*, 28). "For the first three centuries the almost universal practice of baptism was . . . that those who were baptized, were plunged, submerged, immersed into the water" (*Christian Institutions*, p. 21). See further, BAPTISM; LITERATURE, SUB-APOSTOLIC, II, 5.

**7. Greek Church**

LITERATURE.—James Quinter, *Triune Immersion as the Apostolic Form of Christian Baptism*; C. F. Yoder, *God's Means of Grace*, Brethren Pub. House, Elgin, Ill., U.S.A.; Smith, *Dict. of Christian Antiquities*; Hastings, *ERE*; Bible Dicts.; Church Fathers; Church Histories, and Histories of Baptism.

DANIEL WEBSTER KURTZ

**TRINITY**, trin'i-ti:

1. The Term "Trinity"
2. Purely a Revealed Doctrine
3. No Rational Proof of It
4. Finds Support in Reason
5. Not Clearly Revealed in the OT
6. Prepared for in the OT
7. Presupposed Rather Than Inculcated in the NT
8. Revealed in Manifestation of Son and Spirit
9. Implied in the Whole NT
10. Conditions the Whole Teaching of Jesus

11. Father and Son in Johannine Discourses
12. Spirit in Johannine Discourses
13. The Baptismal Formula
14. Genuineness of Baptismal Formula
15. Paul's Trinitarianism
16. Conjunction of the Three in Paul
17. Trinitarianism of Other NT Writers
18. Variations in Nomenclature
19. Implications of "Son" and "Spirit"
20. The Question of Subordination
21. Witness of the Christian Conscience
22. Formulation of the Doctrine

LITERATURE

The term "Trinity" is not a Bib. term, and we are not using Bib. language when we define what is expressed by it as the doctrine that there is one only and true God, but in the unity of the Godhead there are three coeternal and coequal Persons, the same in substance but distinct in subsistence. A doctrine so defined can be spoken of as a Bib. doctrine only on the principle that the sense of Scripture is Scripture. And the definition of a Bib. doctrine in such un-Bib. language can be justified only on the principle that it is better to preserve the truth of Scripture than the words of Scripture. The doctrine of the Trinity lies in Scripture in solution; when it is crystallized from its solvent it does not cease to be Scriptural, but only comes into clearer view. Or, to speak without figure, the doctrine of the Trinity is given to us in Scripture, not in formulated definition, but in fragmentary allusions; when we assemble the *dissecta membra* into their organic unity, we are not passing from Scripture, but entering more thoroughly into the meaning of Scripture. We may state the doctrine in technical terms, supplied by philosophical reflection; but the doctrine stated is a genuinely Scriptural doctrine.

**1. The Term "Trinity"**

In point of fact, the doctrine of the Trinity is purely a revealed doctrine. That is to say, it embodies a truth which has never been discovered, and is indiscoverable, by natural reason. With all his searching, man has not been able to find out for himself the deepest things of God. Accordingly, ethnic thought has never attained a Trinitarian conception of God, nor does any ethnic religion present in its representations of the Divine being any analogy to the doctrine of the Trinity.

**2. Purely a Revealed Doctrine**

Triads of divinities, no doubt, occur in nearly all polytheistic religions, formed under very various influences. Sometimes, as in the Egypt triad of Osiris, Isis and Horus, it is the analogy of the human family with its father, mother and son which lies at their basis. Sometimes they are the effect of mere syncretism, three deities worshipped in different localities being brought together in the common worship of all. Sometimes, as in the Hindu triad of Brahma, Vishnu and Shiva, they represent the cyclic movement of a pantheistic evolution, and symbolize the three stages of Being, Becoming and Dissolution. Sometimes they are the result apparently of nothing more than an odd human tendency to think in threes, which has given the number three widespread standing as a sacred number (so H. Usener). It is no more than was to be anticipated, that one or another of these triads should now and again be pointed to as the replica (or even the original) of the Christian doctrine of the Trinity. Gladstone found the Trinity in the Homeric mythology, the trident of Poseidon being its symbol. Hegel very naturally found it in the Hindu Trimurti, which indeed is very like his pantheizing notion of what the Trinity is. Others have perceived it in the Buddhist Triratna (Söderblom); or (despite their crass dualism) in some speculations of Parseeism; or, more frequently, in the notional triad of Platonism (e.g. Knapp); while Jules Martin is quite sure that it is present in Philo's neo-Stoical doctrine of the "powers," esp. when applied to the explanation of Abraham's three visitors. Of late years, eyes have been turned rather to Babylonia; and H. Zimmermann finds a possible forerunner of the Trinity in a Father, Son, and Intercessor, which he discovers in its mythology. It should be needless to say that none of these triads has the slightest resemblance to the Christian doctrine of the Trinity. The Christian doctrine of the Trinity embodies much more than the notion of "threeness," and beyond their "threeness" these triads have nothing in common with it.



As the doctrine of the Trinity is undiscoverable by reason, so it is incapable of proof from reason.

There are no analogies to it in Nature, not even in the spiritual nature of man, who is made in the image of God. In His trinitarian mode of being, God is unique; and, as there is nothing in the universe like Him in this respect, so there is nothing which can help us to comprehend Him. Many attempts have, nevertheless, been made to construct a rational proof of the Trinity of the Godhead. Among these there are two which are particularly attractive, and have therefore been put forward again and again by speculative thinkers through all the Christian ages. These are derived from the implications, in the one case, of self-consciousness; in the other, of love. Both self-consciousness and love, it is said, demand for their very existence an object over against which the self stands as subject. If we conceive of God as self-conscious and loving, therefore, we cannot help conceiving of Him as embracing in His unity some form of plurality. From this general position both arguments have been elaborated, however, by various thinkers in very varied forms.

The former of them, for example, is developed by a great 17th-cent. theologian—Bartholomew Keckerman (1614)—as follows: God is self-conscious thought; and God's thought must have a perfect object, existing eternally before it; this object to be perfect must be itself God; and as God is one, this object which is God must be the God that is one. It is essentially the same argument which is popularized in a famous paragraph (§73) of Lessing's *The Education of the Human Race*. Must not God have an absolutely perfect representation of Himself—that is, a representation in which everything that is in Him is found? And would everything that is in God be found in this representation if His necessary reality were not found in it? If everything, everything without exception, that is in God is to be found in this representation, it cannot, therefore, remain a mere empty image, but must be an actual duplication of God. It is obvious that arguments like this prove too much. If God's representation of Himself, to be perfect, must possess the same kind of reality that He Himself possesses, it does not seem easy to deny that His representations of everything else must possess objective reality. And this would be as much as to say that the eternal objective coexistence of all that God can conceive is given in the very idea of God; and that is open pantheism. The logical flaw lies in including in the perfection of a representation qualities which are not proper to representations, however perfect. A perfect representation must, of course, have all the reality proper to a representation; but objective reality is so little proper to a representation that a representation acquiring it would cease to be a representation. This fatal flaw is not transcended, but only covered up, when the argument is compressed, as it is in most of its modern presentations, in effect to the mere assertion that the condition of self-consciousness is a real distinction between the thinking subject and the thought object, which, in God's case, would be between the subject ego and the object ego. Why, however, should we deny to God the power of self-contemplation enjoyed by every finite spirit, save at the cost of the distinct hypostatizing of the contemplant and the contemplated self, it is hard to understand. Nor is it always clear that what we get is a distinct hypostatization rather than a distinct substantializing of the contemplant and contemplated ego: not two persons in the Godhead so much as two Gods. The discovery of the third hypostasis—the Holy Spirit—remains meanwhile, to all these attempts rationally to construct a Trinity in the Divine Being, a standing puzzle which finds only a very artificial solution.

The case is much the same with the argument derived from the nature of love. Our sympathies go out to that old Valentinian writer—possibly it was Valentinus himself—who reasoned—perhaps he was the first so to reason—that "God is all love," "but love is not love unless there be an object of love." And they go out more richly still to Augustine, when, seeking a basis, not for a theory of emanations, but for the doctrine of the Trinity, he analyzes this love which God is into the triple implication of "the lover," "the loved" and "the love itself" and sees in this trinary of love an analogue of the Triune God. It requires, however, only that the argument thus broadly suggested should be developed into its details for its artificiality to become apparent. Richard of St. Victor works it out as follows: It belongs to the nature of *amor* that it should turn to another as *caritas*. This other, in God's case, cannot be the world;

since such love of the world would be inordinate. It can only be a person; and a person who is God's equal in eternity, power and wisdom. Since, however, there cannot be two Divine substances, these two Divine persons must form one and the same substance. The best love cannot, however, confine itself to these two persons: it must become *confectio* by the desire that a third should be equally loved as they love one another. Thus love, when perfectly conceived, leads necessarily to the Trinity, and since God is all He can be, this Trinity must be real. Modern writers (Sartorius, Schöherlein, J. Müller, Liebner, most lately R. H. Grütz-macher) do not seem to have essentially improved upon such a statement as this. And after all is said, it does not appear clear that God's own all-perfect Being could not supply a satisfying object of His all-perfect love. To say that in its very nature love is self-communicative, and therefore implies an object other than self, seems an abuse of figurative language.

Perhaps the ontological proof of the Trinity is nowhere more attractively put than by Jonathan Edwards. The peculiarity of his presentation of it lies in an attempt to add plausibility to it by a doctrine of the nature of spiritual ideas or ideas of spiritual things, such as thought, love, fear, in general. Ideas of such things, he urges, are just repetitions of them, so that he who has an idea of any act of love, fear, anger or any other act or motion of the mind, simply so far repeats the motion in question; and if the idea be perfect and complete, the original motion of the mind is absolutely reduplicated. Edwards presses this so far that he is ready to contend that if a man could have an absolutely perfect idea of all that was in his mind at any past moment, he would really, to all intents and purposes, be over again what he was at that moment. And if he could perfectly contemplate all that is in his mind at any given moment, as it is and at the same time that it is there in its first and direct existence, he would really be two at that time, he would be twice at once: "The idea he has of himself would be himself again." This now is the case with the Divine Being. "God's idea of Himself is absolutely perfect, and therefore is an express and perfect image of Him, exactly like Him in every respect. . . . But that which is the express, perfect image of God and in every respect like Him is God, to all intents and purposes, because there is nothing wanting: there is nothing in the Deity that renders it the Deity but what has something exactly answering to it in this image, which will therefore also render that the Deity." The Second Person of the Trinity being thus attained, the argument advances. "The Godhead being thus begotten of God's loving [having?] an idea of Himself and showing forth in a distinct Subsistence or Person in that idea, there proceeds a most pure act, and an infinitely holy and sacred energy arises between the Father and the Son in mutually loving and delighting in each other. . . . The Deity becomes all act, the Divine essence itself flows out and is as it were breathed forth in love and joy. So that the Godhead therein stands forth in yet another manner of Subsistence, and there proceeds the Third Person in the Trinity, the Holy Spirit, viz. the Deity in act, for there is no other act but the act of the will." The inconclusiveness of the reasoning lies on the surface. The mind does not consist in its states, and the repetition of its states would not, therefore, duplicate or triplicate it. If it did, we should have a plurality of Beings, not of Persons in one Being. Neither God's perfect idea of Himself nor His perfect love of Himself reproduces Himself. He differs from His idea and His love of Himself precisely by that which distinguishes His Being from His acts. When it is said, then, that there is nothing in the Deity which renders it the Deity but what has something answering to it in its image of itself, it is enough to respond—except the Deity itself. What is wanting to the image to make it a second Deity is just objective reality.

Inconclusive as all such reasoning is, however, considered as rational demonstration of the reality

of the Trinity, it is very far from possessing no value. It carries home to us in a very suggestive way the superiority of the Trinitarian conception of God to the conception of Him as an abstract monad, and thus brings important rational support to the doctrine of the Trinity, when once that doctrine has been given us by revelation. If it is not quite possible to say that we cannot conceive of God as eternal self-consciousness and eternal love, without conceiving Him as a Trinity, it does seem quite necessary to say that when we conceive Him as a Trinity, new fulness, richness, force are given to our conception of Him as a self-conscious, loving Being, and therefore we conceive Him more adequately than as a monad, and no one who has ever once conceived Him as a Trinity can ever again satisfy himself with a monad-

#### 4. Supported by Reason

istic conception of God. Reason thus not only performs the important negative service to faith in the Trinity, of showing the self-consistency of the doctrine and its consistency with other known truth, but brings this positive rational support to it of discovering in it the only adequate conception of God as self-conscious spirit and living love. Difficult, therefore, as the idea of the Trinity in itself is, it does not come to us as an added burden upon our intelligence; it brings us rather the solution of the deepest and most persistent difficulties in our conception of God as infinite moral Being, and illuminates, enriches and elevates all our thought of God. It has accordingly become a commonplace to say that Christian theism is the only stable theism. That is as much as to say that theism requires the enriching conception of the Trinity to give it a permanent hold upon the human mind—the mind finds it difficult to rest in the idea of an abstract unity for its God; and that the human heart cries out for the living God in whose Being there is that fullness of life for which the conception of the Trinity alone provides.

So strongly is it felt in wide circles that a Trinitarian conception is essential to a worthy idea of God, that there is abroad a deep-seated unwillingness to allow that God could ever have made Himself known otherwise than as a Trinity. From this point of view it is inconceivable that the OT revelation should know nothing of the Trinity.

Accordingly, I. A. Dorner, for example, reasons thus: "If, however—and this is the faith of universal Christendom—a living idea of God must be thought in some way after a Trinitarian fashion, it must be antecedently probable that traces of the Trinity cannot be lacking in the OT, since its idea of God is a living or historical one." Whether there really exist traces of the idea of the Trinity in the OT, however, is a nice question. Certainly we cannot speak broadly of the revelation of the doctrine of the Trinity in the OT. It is a plain matter of fact that none who have depended on the revelation embodied in the OT alone have ever attained to the doctrine of the Trinity. It is another question, however, whether there may not exist in the pages of the OT turns of expression or records of occurrences in which one already acquainted with the doctrine of the Trinity may fairly see indications of an underlying implication of it. The older writers discovered intimations of the Trinity in such phenomena as the pl. form of the Divine name *Elohim*, the occasional employment with reference to God of pl. pronouns ("Let us make man in our image," Gen 1 26; 3 22; 11 7; Isa 6 8), or of pl. verbs (Gen 20 13; 35 7), certain repetitions of the name of God which seem to distinguish between God and God (Gen 19 27; Ps 45 6, 7; 110 1; Hos 1 7), threefold liturgical formulas (Dt 16 4; Nu 6 24, 26; Isa 6 3), a certain tendency to hypostatize the conception of Wisdom (Prov 8), and esp. the remarkable phenomena connected with the appearances of the Angel of Jeh (Gen 16 2-13; 22 11, 16; 31 11, 13; 48 15, 16; Ex 3 2, 4, 5; Jgs 13 20-22). The tendency of more recent authors is to appeal, not so much to specific texts of the OT, as to the very "organism of revelation" in the OT, in which there is perceived an underlying suggestion "that all things owe their existence and persistence to a threefold cause," both with reference to the first creation, and, more plainly, with reference to the second creation. Passages like Ps 33 6; Isa 61 1; 63 9-12; Hag 2 5, 6, in which God and His Word and His Spirit are brought together, co-causes of effects, are adduced. A tendency is pointed out to hypostatize the Word of God on the one hand (e.g. Gen 1 3; Ps 33 6; 107 20; 119 87; 147 15-18; Isa 55 11); and, esp. in Ezk and the later Prophets, the Spirit of God, on the other (e.g. Gen 1 2; Isa 48 16; 63 10; Ezk 2 2; 8 3; Zec 7 12). Suggestions—in Isa for instance (7 14; 9 6)—of the Deity of the Messiah are appealed to. And if the occasional occurrence of pl. verbs and pronouns referring to God, and the pl. form of the name *Elohim*, are not insisted upon as in themselves evidence of a multiplicity in the Godhead, yet a certain weight is lent them as witnesses that "the God of revelation is no abstract unity, but the living, true God, who in the fullness of His life embraces the highest variety" (Bavinck). The upshot of it all is that it is very generally felt that, somehow, in the OT development of the idea of God there is a suggestion that the Deity is not a simple monad, and that thus a preparation is made for the revelation of the Trinity yet to come. It would seem clear that we must recognize in the OT doctrine of the relation of God to His revelation by the creative Word and the Spirit, at least the germ of the distinctions in the Godhead afterward fully made known

in the Christian revelation. And we can scarcely stop there. After all is said, in the light of the later revelation, the Trinitarian interpretation remains the most natural one of the phenomena which the older writers frankly interpreted as intimations of the Trinity; esp. of those connected with the descriptions of the Angel of Jeh, no doubt, but also even of such a form of expression as meets us in the "Let us make man in our image" of Gen 1 26—for surely ver 27: "And God created man in his own image," does not encourage us to take the preceding verse as announcing that man was to be created in the image of the angels. This is not an illegitimate reading of NT ideas back into the text of the OT; it is only reading the text of the OT under the illumination of the NT revelation. The OT may be likened to a chamber richly furnished but dimly lighted; the introduction of light brings into it nothing which was not in it before; but it brings out into clearer view much of what is in it but was only dimly or even not at all perceived before. The mystery of the Trinity is not revealed in the OT; but the mystery of the Trinity underlies the OT revelation, and here and there almost comes into view. Thus the OT revelation of God is not corrected by the fuller revelation which follows it, but only perfected, extended and enlarged.

It is an old saying that what becomes patent in the NT was latent in the OT. And it is important

that the continuity of the revelation of 6. Prepared God contained in the two Testaments for in should not be overlooked or obscured. the OT If we find some difficulty in perceiving for ourselves, in the OT, definite points of attachment for the revelation of the Trinity, we cannot help perceiving with great clearness in the NT abundant evidence that its writers felt no incongruity whatever between their doctrine of the Trinity and the OT conception of God. The NT writers certainly were not conscious of being "setters forth of strange gods." To their own apprehension they worshipped and proclaimed just the God of Israel; and they laid no less stress than the OT itself upon His unity (Jn 17 3; 1 Cor 8 4; 1 Tim 2 5). They do not, then, place two new gods by the side of Jeh, as alike with Him to be served and worshipped; they conceive Jeh as Himself at once Father, Son and Spirit. In presenting this one Jeh as Father, Son and Spirit, they do not even betray any lurking feeling that they are making innovations. Without apparent misgiving they take over OT passages and apply them to Father, Son and Spirit indifferently. Obviously they understand themselves, and wish to be understood, as setting forth in the Father, Son and Spirit just the one God that the God of the OT revelation is; and they are as far as possible from recognizing any breach between themselves and the Fathers in presenting their enlarged conception of the Divine Being. This may not amount to saying that they saw the doctrine of the Trinity everywhere taught in the OT. It certainly amounts to saying that they saw the Triune God whom they worshipped in the God of the OT revelation, and felt no incongruity in speaking of their Triune God in the terms of the OT revelation. The God of the OT was their God, and their God was a Trinity, and their sense of the identity of the two was so complete that no question as to it was raised in their minds.

The simplicity and assurance with which the NT writers speak of God as a Trinity have, however, a further implication. If they betray no sense of novelty in so speaking of Him, this is undoubtedly in part because it was no longer a novelty so to speak of Him. It is clear, in other words, that, as we read the NT, we are not witnessing the birth of a new conception of God. What we meet with in its pages is a firmly established conception of God underlying and giving its tone to the whole fabric. It is not in a text here and there that the NT bears its testimony to the doctrine of the Trinity. The whole book is Trinitarian to the core; all its teaching is built on the assump-

## 7. Pre-supposed in the NT

tion of the Trinity; and its allusions to the Trinity are frequent, cursory, easy and confident. It is with a view to the cursoryness of the allusions to it in the NT that it has been remarked that "the doctrine of the Trinity is not so much heard as overheard in the statements of Scripture." It would be more exact to say that it is not so much inculcated as presupposed. The doctrine of the Trinity does not appear in the NT in the making, but as already made. It takes its place in its pages, as Gunkel phrases it, with an air almost of complaint, already "in full completeness" (*völlig fertig*), leaving no trace of its growth. "There is nothing more wonderful in the history of human thought," says Sanday, with his eye on the appearance of the doctrine of the Trinity in the NT, "than the silent and imperceptible way in which this doctrine, to us so difficult, took its place without struggle—and without controversy—among accepted Christian truths." The explanation of this remarkable phenomenon is, however, simple. Our NT is not a record of the development of the doctrine or of its assimilation. It everywhere presupposes the doctrine as the fixed possession of the Christian community; and the process by which it became the possession of the Christian community lies behind the NT.

We cannot speak of the doctrine of the Trinity, therefore, if we study exactness of speech, as revealed in the NT, any more than we can speak of it as revealed in the OT.

### 8. Manifested in Son and Spirit

The OT was written before its revelation; the NT after it. The revelation itself was made not in word but in deed. It was made in the incarnation of God the Son, and the outpouring of God the Holy Spirit. The relation of the two Testaments to this revelation is in the one case that of preparation for it, and in the other that of product of it. The revelation itself is embodied just in Christ and the Holy Spirit. This is as much as to say that the revelation of the Trinity was incidental to, and the inevitable effect of, the accomplishment of redemption. It was in the coming of the Son of God in the likeness of sinful flesh to offer Himself a sacrifice for sin; and in the coming of the Holy Spirit to convict the world of sin, of righteousness and of judgment, that the Trinity of Persons in the Unity of the Godhead was once for all revealed to men. Those who knew God the Father, who loved them and gave His own Son to die for them; and the Lord Jesus Christ, who loved them and delivered Himself up an offering and sacrifice for them; and the Spirit of Grace, who loved them and dwelt within them a power not themselves, making for righteousness, knew the Triune God and could not think or speak of God otherwise than as triune. The doctrine of the Trinity, in other words, is simply the modification wrought in the conception of the one only God by His complete revelation of Himself in the redemptive process. It necessarily waited, therefore, upon the completion of the redemptive process for its revelation, and its revelation, as necessarily, lay complete in the redemptive process.

From this central fact we may understand more fully several circumstances connected with the revelation of the Trinity to which allusion has been made. We may from it understand, for example, why the Trinity was not revealed in the OT. It may carry us a little way to remark, as it has been customary to remark since the time of Gregory of Nazianzus, that it was the task of the OT revelation to fix firmly in the minds and hearts of the people of God the great fundamental truth of the unity of the Godhead; and it would have been dangerous to speak to them of the plurality within this unity until this task had been fully accomplished. The real reason for the delay in the revelation of the Trinity, however, is grounded in the secular development of the redemptive purpose of God: the times were not

ripe for the revelation of the Trinity in the unity of the Godhead until the fullness of the time had come for God to send forth His Son unto redemption, and His Spirit unto sanctification. The revelation in word must needs wait upon the revelation in fact, to which it brings its necessary explanation, no doubt, but from which also it derives its own entire significance and value. The revelation of a Trinity in the Divine unity as a mere abstract truth without relation to manifested fact, and without significance to the development of the kingdom of God, would have been foreign to the whole method of the Divine procedure as it lies exposed to us in the pages of Scripture. Here the working-out of the Divine purpose supplies the fundamental principle to which all else, even the progressive stages of revelation itself, is subsidiary; and advances in revelation are ever closely connected with the advancing accomplishment of the redemptive purpose. We may understand also, however, from the same central fact, why it is that the doctrine of the Trinity lies in the NT rather in the form of allusions than in express teaching, why it is rather everywhere presupposed, coming only here and there into incidental expression, than formally inculcated. It is because the revelation, having been made in the actual occurrences of redemption, was already the common property of all Christian hearts. In speaking and writing to one another, Christians, therefore, rather spoke out of their common Trinitarian consciousness, and reminded one another of their common fund of belief, than instructed one another in what was already the common property of all. We are to look for, and we shall find, in the NT allusions to the Trinity, rather evidence of how the Trinity, believed in by all, was conceived by the authoritative teachers of the church, than formal attempts, on their part, by authoritative declarations, to bring the church into the understanding that God is a Trinity.

The fundamental proof that God is a Trinity is supplied thus by the fundamental revelation of the

Trinity in fact: that is to say, in the incarnation of God the Son and the outpouring of God the Holy Spirit.

### 9. Implied in the Whole NT

In a word, Jesus Christ and the Holy Spirit are the fundamental proof of the doctrine of the Trinity. This is as much as to say that all the evidence of whatever kind, and from whatever source derived, that Jesus Christ is God manifested in the flesh, and that the Holy Spirit is a Divine Person, is just so much evidence for the doctrine of the Trinity; and that when we go to the NT for evidence of the Trinity we are to seek it, not merely in the scattered allusions to the Trinity as such, numerous and instructive as they are, but primarily in the whole mass of evidence which the NT provides of the Deity of Christ and the Divine personality of the Holy Spirit. When we have said this, we have said in effect that the whole mass of the NT is evidence for the Trinity. For the NT is saturated with evidence of the Deity of Christ and the Divine personality of the Holy Spirit. Precisely what the NT is, is the documentation of the religion of the incarnate Son and of the outpoured Spirit, that is to say, of the religion of the Trinity, and what we mean by the doctrine of the Trinity is nothing but the formulation in exact language of the conception of God presupposed in the religion of the incarnate Son and outpoured Spirit. We may analyze this conception and adduce proof for every constituent element of it from the NT declarations. We may show that the NT everywhere insists on the unity of the Godhead; that it constantly recognizes the Father as God, the Son as God and the Spirit as God; and that it cursorily presents these three to us as distinct Persons. It is not necessary, however, to enlarge here on facts so obvious. We may content ourselves with simply observing that to the NT there is but one only living and true God; but that to it Jesus Christ and the Holy Spirit are each God in the fullest sense of the term; and yet Father, Son and Spirit stand over against each other as I, and Thou, and He. In this composite fact the NT gives us the doctrine of the Trinity. For the doctrine of the Trinity is but the statement in well-guarded language of this composite fact. Through-

out the whole course of the many efforts to formulate the doctrine exactly, which have followed one another during the entire history of the church, indeed, the principle which has ever determined the result has always been determination to do justice in conceiving the relations of God the Father, God the Son and God the Spirit, on the one hand to the unity of God, and, on the other, to the true Deity of the Son and Spirit and their distinct personalities. When we have said these three things, then—that there is but one God, that the Father and the Son and the Spirit is each God, that the Father and the Son and the Spirit is each a distinct person—we have enunciated the doctrine of the Trinity in its completeness.

That this doctrine underlies the whole NT as its constant presupposition and determines everywhere its forms of expression is the primary fact to be noted. We must not omit explicitly to note, however, that it now and again also, as occasion arises for its incidental enunciation, comes itself to expression in more or less completeness of statement. The passages in which the three Persons of the Trinity are brought together are much more numerous than, perhaps, is generally supposed; but it should be recognized that the formal collocation of the elements of the doctrine naturally is relatively rare in writings which are occasional in their origin and practical rather than doctrinal in their immediate purpose. The three Persons already come into view as Divine Persons in the annunciation of the birth of Our Lord: 'The Holy Ghost shall come upon thee,' said the angel to Mary, 'and the power of the Most High shall overshadow thee: wherefore also the holy thing which is to be born shall be called the Son of God' (Lk 1 35 m; cf Mt 1 18 ff). Here the Holy Ghost is the active agent in the production of an effect which is also ascribed to the power of the Most High, and the child thus brought into the world is given the great designation of "Son of God." The three Persons are just as clearly brought before us in the account of Mt (1 18 ff), though the allusions to them are dispersed through a longer stretch of narrative, in the course of which the Deity of the child is twice intimated (ver 21: 'It is He that shall save His people from their sins'; ver 23: 'They shall call His name Immanuel; which is, being interpreted, *God-with-us*'). In the baptismal scene which finds record by all the evangelists at the opening of Jesus' ministry (Mt 3 16,17; Mk 1 10,11; Lk 3 21,22; Jn 1 32-34), the three Persons are thrown up to sight in a dramatic picture in which the Deity of each is strongly emphasized. From the open heavens the Spirit descends in visible form, and 'a voice came out of the heavens, Thou art my Son, the Beloved, in whom I am well pleased.' Thus care seems to have been taken to make the advent of the Son of God into the world the revelation also of the Triune God, that the minds of men might as smoothly as possible adjust themselves to the preconditions of the Divine redemption which was in process of being wrought out.

With this as a starting-point, the teaching of Jesus is Trinitarianly conditioned throughout. He has much to say of God His Father, from whom as His Son He is in some true sense distinct, and with whom He is in some equally true sense one. And He has much to say of the Spirit, who represents Him as He represents the Father, and by whom He works as the Father works by Him. It is not merely in the Gospel of Jn that such representations occur in the teaching of Jesus. In the Synoptics, too, Jesus claims a Sonship to God which is unique (Mt 11 27; 24 36; Mk 13 32; Lk 10 22; in the following

passages the title of "Son of God" is attributed to Him and accepted by Him: Mt 4 6; 8 29; 14 33; 27 40,43,54; Mk 3 11; 12 6-8; 15 39; Lk 4 41; 22 70; cf Jn 1 34,49; 9 35; 11 27), and which involves an absolute community between the two in knowledge, say, and power: both Mt (11 27) and Lk (10 22) record His great declaration that He knows the Father and the Father knows Him with perfect mutual knowledge: "No one knoweth the Son, save the Father; neither doth any know the Father, save the Son." In the Synoptics, too, Jesus speaks of employing the Spirit of God Himself for the performance of His works, as if the activities of God were at His disposal: "I by the Spirit of God"—or as Lk has it, "by the finger of God"—"cast out demons" (Mt 12 28; Lk 11 20; cf the promise of the Spirit in Mk 13 11; Lk 12 12).

It is in the discourses recorded in Jn, however, that Jesus most copiously refers to the unity of Himself, as the Son, with the Father, and to the mission of the Spirit from Himself as the dispenser of the Divine activities. Here He not only with great directness declares that He and the Father are one (10 30; cf 17 11,21,22,25) with a unity of interpenetration ("The Father is in me, and I in the Father," 10 38; cf 16 10,11), so that to have seen Him was to have seen the Father (14 9; cf 15 21); but He removes all doubt as to the essential nature of His oneness with the Father by explicitly asserting His eternity ("Before Abraham was born, I am," Jn 8 58). His co-eternity with God ("had with thee before the world was," 17 5; cf 17 18; 6 62), His eternal participation in the Divine glory itself ("the glory which I had with thee," in fellowship, community with Thee "before the world was," 17 5). So clear is it that in speaking currently of Himself as God's Son (5 25; 9 35; 11 4; cf 10 36), He meant, in accordance with the underlying significance of the idea of sonship in Sem speech (founded on the natural implication that whatever the father is that the son is also; cf 16 15; 17 10), to make Himself, as the Jews with exact appreciation of His meaning perceived, "equal with God" (5 18), or, to put it brusquely, just "God" (10 33). How He, being thus equal or rather identical with God, was in the world, He explains as involving a coming forth (*ἐξῆλθεν, exēlthon*) on His part, not merely from the presence of God (*ἀπό, apó*, 16 30; cf 13 3) or from fellowship with God (*παρά, pará*, 16 27; 17 8), but from out of God Himself (*ἐκ, ek*, 8 42; 16 28). And in the very act of thus asserting that His eternal home is in the depths of the Divine Being, He throws up, into as strong an emphasis as stressed pronouns can convey, His personal distinctness from the Father. 'If God were your Father,' says He (8 42), 'ye would love me: for I came forth and am come out of God; for neither have I come of myself, but it was He that sent me.' Again, He says (16 26,27): 'In that day ye shall ask in my name: and I say not unto you that I will make request of the Father for you; for the Father Himself loveth you, because ye have loved me, and have believed that it was from fellowship with the Father that I came forth; I came from out of the Father, and have come into the world.' Less pointedly, but still distinctly, He says again (17 8): 'They know of a truth that it was from fellowship with Thee that I came forth, and they believed that it was Thou that didst send me.' It is not necessary to illustrate more at large a form of expression so characteristic of the discourses of Our Lord recorded by Jn that it meets us on every page: a form of expression which combines a clear implication of a unity of Father and Son which is identity of Being, and an equally clear implication of a distinction of Person between them such as allows not merely for the play of emotions between them, as, for instance, of love (17 24; cf 15 9 [3 35]; 14 31), but also of an action and reaction upon one another which argues a high measure, if not of exteriority, yet certainly of exteriorization. Thus, to instance only one of the most outstanding facts of Our Lord's discourses (not indeed confined to those in John's Gospel, but found also in His sayings recorded in the Synoptists, as e.g. Lk 4 43 (cf J Mk 1 38); 9 48; 10 16; 4 34; 5 32; 7 19; 19 10), He continually represents Himself as on the one hand sent by God, and as, on the other, having come forth from the Father (e.g. Jn 8 42; 10 36; 17 3; 5 23, *et saepe*).

It is more important to point out that these phenomena of interrelationship are not confined to the Father and Son, but are extended also to the Spirit. Thus, for example, in a context in which Our Lord had emphasized in the strongest manner His own essential unity and continued interpenetration with the Father ("If ye had known me, ye would have known my Father also"; "He that hath seen me hath seen the Father"; "I am in the Father, and the Father in me"; "The Father abiding in me doeth his

**11. Father and Son in Johannine Discourses**

**12. Spirit in Johannine Discourses**

works," Jn 14 7.9.10), we read as follows (Jn 14 16-26): 'And I will make request of the Father, and He shall give you another [thus sharply distinguished from Our Lord as a distinct Person] Advocate, that He may be with you forever, the Spirit of Truth. He abideth with you and shall be in you. I will not leave you orphans; I come unto you, but the Father will love me, he will keep my word; and my Father will love him and we [that is, both Father and Son] will come unto him and make our abode with him. These things have I spoken unto you while abiding with you. But the Advocate, the Holy Spirit, whom the Father will send in my name, He shall teach you all things, and bring to your remembrance all that I said unto you.' It would be impossible to speak more distinctly of three who were yet one. The Father, Son and Spirit are constantly distinguished from one another—the Son makes request of the Father, and the Father in response to this request gives an Advocate, "another" than the Son, who is sent in the Son's name. And yet the oneness of these three is so kept in sight that the coming of this "another Advocate" is spoken of without embarrassment as the coming of the Son Himself (vs 18,19,20,21), and indeed as the coming of the Father and the Son (ver 23). There is a sense, then, in which, when Christ goes away, the Spirit comes in His stead; there is also a sense in which, when the Spirit comes, Christ comes in Him; and with Christ's coming the Father comes too. There is a distinction between the Persons brought into view; and with it an identity among them; for both of which allowance must be made. The same phenomena meet us in other passages. Thus, we read again (15 26): 'But when there is come the Advocate whom I will send unto you from [fellowship with] the Father, the Spirit of Truth, which goeth forth from [fellowship with] the Father, He shall bear witness of me.' In the compass of this single verse, it is intimated that the Spirit is personally distinct from the Son, and yet, like Him, has His eternal home (in fellowship) with the Father, from whom He, like the Son, comes forth for His saving work, being sent thereunto, however, not in this instance by the Father, but by the Son.

This last feature is even more strongly emphasized in yet another passage in which the work of the Spirit in relation to the Son is presented as closely parallel with the work of the Son in relation to the Father (16 5 ff). 'But now I go unto Him that sent me. . . . Nevertheless I tell you the truth; it is expedient for you that I go away; for, if I go not away the Advocate will not come unto you; but if I go I will send Him unto you. And He, after He is come, will convict the world. . . . of righteousness because I go to the Father and ye behold me no more. . . . I have yet many things to say unto you, but ye cannot bear them now. Howbeit when He, the Spirit of truth is come, He shall guide you into all the truth; for He shall not speak from Himself; but what things soever He shall hear, He shall speak, and He shall declare unto you the things that are to come. He shall glorify me: for He shall take of mine and shall show it unto you. All things whatsoever the Father hath are mine; therefore said I that He taketh of mine, and shall declare it unto you.' Here the Spirit is sent by the Son, and comes in order to complete and apply the Son's work, receiving His whole commission from the Son—not, however, in derogation of the Father, because when we speak of the things of the Son, that is to speak of the things of the Father.

It is not to be said, of course, that the doctrine of the Trinity is formulated in passages like these, with which the whole mass of Our Lord's discourses in Jn are strewn; but it certainly is presupposed in them, and that is, considered from the point of view of their probative force, even better. As we read we are kept in continual contact with three Persons who act, each as a distinct person, and yet who are in a deep, underlying sense, one. There is but one God—there is never any question of that—and yet this Son who has been sent into the world by God not only represents God but is God, and this Spirit whom the Son has in turn sent unto the world is also Himself God. Nothing could be clearer than that the Son and Spirit are distinct Persons, unless indeed it be that the Son of God is just God the Son and the Spirit of God just God the Spirit.

Meanwhile, the nearest approach to a formal announcement of the doctrine of the Trinity which is recorded from Our Lord's lips, or

**13. The Baptismal Formula** perhaps we may say, which is to be found in the whole compass of the NT, has been preserved for us, not by John, but by one of the synoptists. It too, however, is only incidentally introduced, and has for its main object something very different from formulating the doctrine of the Trinity. It is embodied in the great commission which the resurrected Lord gave His disciples to be their "marching orders" "even unto the end of the world": "Go

ye therefore, and make disciples of all the nations, baptizing them into the name of the Father and of the Son and of the Holy Spirit" (Mt 28 19). In seeking to estimate the significance of this great declaration, we must bear in mind the high solemnity of the utterance, by which we are required to give its full value to every word of it. Its phrasing is in any event, however, remarkable. It does not say, "In the names [plural] of the Father and of the Son and of the Holy Ghost"; nor yet (what might be taken to be equivalent to that), "In the name of the Father, and in the name of the Son, and in the name of the Holy Ghost," as if we had to deal with three separate Beings. Nor, on the other hand, does it say, "In the name of the Father, Son and Holy Ghost," as if "the Father, Son and Holy Ghost" might be taken as merely three designations of a single person. With stately impressiveness it asserts the unity of the three by combining them all within the bounds of the single Name; and then throws up into emphasis the distinctness of each by introducing them in turn with the repeated article: "In the name of the Father, and of the Son, and of the Holy Ghost" (AV). These three, the Father, and the Son, and the Holy Ghost, each stand in some clear sense over against the others in distinct personality: these three, the Father, and the Son, and the Holy Ghost, all unite in some profound sense in the common participation of the one Name. Fully to comprehend the implication of this mode of statement, we must bear in mind, further, the significance of the term, "the name," and the associations laden with which it came to the recipients of this commission. For the Hebrew did not think of the name, as we are accustomed to do, as a mere external symbol; but rather as the adequate expression of the innermost being of its bearer. In His Name the Being of God finds expression; and the Name of God—"this glorious and fearful name, Jeh thy God" (Dt 28 58)—was accordingly a most sacred thing, being indeed virtually equivalent to God Himself. It is no solecism, therefore, when we read (Isa 30 27), "Behold, the name of Jeh cometh"; and the parallelisms are most instructive when we read (Isa 59 19): 'So shall they fear the Name of Jeh from the west, and His glory from the rising of the sun; for He shall come as a stream pent in which the Spirit of Jeh driveth.' So pregnant was the implication of the name, that it was possible for the term to stand absolutely, without adjunction of the name itself, as the sufficient representative of the majesty of Jeh: it was a terrible thing to 'blaspheme the Name' (Lev 24 11). All those over whom Jeh's Name was called were His, His possession to whom He owed protection. It is for His Name's sake, therefore, that afflicted Judah cries to the Hope of Israel, the Saviour thereof in time of trouble: 'O Jeh, Thou art in the midst of us, and Thy Name is called upon us; leave us not' (Jer 14 9); and His people find the appropriate expression of their deepest shame in the lament, 'We have become as they over whom Thou never barest rule; as they upon whom Thy Name was not called' (Isa 63 19); while the height of joy is attained in the cry, 'Thy Name, Jeh, God of Hosts, is called upon me' (Jer 15 16; cf 2 Ch 7 14; Dnl 9 18.19). When, therefore, Our Lord commanded His disciples to baptize those whom they brought to His obedience "into the name of . . ." He was using language charged to them with high meaning. He could not have been understood otherwise than as substituting for the Name of Jeh this other Name "of the Father, and of the Son, and of the Holy Ghost"; and this could not possibly have meant to His disciples anything else than that Jeh was now to be known to them by the new Name, of the Father, and the Son, and the Holy

Ghost. The only alternative would have been that, for the community which He was founding, Jesus was supplanting Jeh by a new God; and this alternative is no less than monstrous. There is no alternative, therefore, to understanding Jesus here to be giving for His community a new Name to Jeh, and that new Name to be the threefold Name of "the Father, and the Son, and the Holy Ghost." Nor is there room for doubt that by "the Son" in this threefold Name, He meant just Himself with all the implications of distinct personality which this carries with it; and, of course, that further carries with it the equally distinct personality of "the Father" and "the Holy Ghost," with whom "the Son" is here associated, and from whom alike "the Son" is here distinguished. This is a direct ascription to Jeh, the God of Israel, of a threefold personality, and is therewith the direct enunciation of the doctrine of the Trinity. We are not witnessing here the birth of the doctrine of the Trinity; that is presupposed. What we are witnessing is the authoritative announcement of the Trinity as the God of Christianity by its Founder, in one of the most solemn of His recorded declarations. Israel had worshipped the one only true God under the Name of Jeh; Christians are to worship the same one only and true God under the Name of "the Father, and the Son, and the Holy Ghost." This is the distinguishing characteristic of Christians; and that is as much as to say that the doctrine of the Trinity is, according to Our Lord's own apprehension of it, the distinctive mark of the religion which He founded.

A passage of such range of implication has, of course, not escaped criticism and challenge. An attempt which cannot be characterized as other than frivolous has even been made to dismiss it from the text of Matthew's Gospel.

**14. Genuineness of Baptismal Formula**

Against this, the whole body of external evidence cries out; and the internal evidence is of itself not less decisive to the same effect. When the "universalism," "ecclasiasticism," and "high theology" of the passage are pleaded against its genuineness, it is forgotten that to the Jesus of Mt there are attributed not only such parables as those of the Leaven and the Mustard Seed, but such declarations as those contained in 8 11,12; 21 43; 24 14; that in this Gospel alone is Jesus recorded as speaking familiarly about His church (16 18; 18 17); and that after the great declaration of 11 27 ff, nothing remained in lofty attribution to be assigned to Him. When these same objections are urged against recognizing the passage as an authentic saying of Jesus' own, it is quite obvious that the Jesus of the evangelists cannot be in mind. The declaration here recorded is quite in character with the Jesus of Matthew's Gospel, as has just been intimated; and no less with the Jesus of the whole NT transmission. It will scarcely do, first to construct a priori a Jesus to our own liking, and then to discard as "unhistorical" all in the NT transmission which would be unnatural to such a Jesus. It is not these discarded passages but our a priori Jesus which is unhistorical. In the present instance, moreover, the historicity of the assailed saying is protected by an important historical relation in which it stands. It is not merely Jesus who speaks out of a Trinitarian consciousness, but all the NT writers as well. The universal possession by His followers of so firm a hold on such a doctrine requires the assumption that some such teaching as is here attributed to Him was actually contained in Jesus' instructions to His followers. Even had it not been attributed to Him in so many words by the record, we should have had to assume that some such declaration had been made by Him. In these circumstances, there can be no good reason to doubt that it was made by Him, when it is expressly attributed to Him by the record.

When we turn from the discourses of Jesus to the writings of His followers with a view to observing how the assumption of the doctrine

**15. Paul's Trinitarianism**

of the Trinity underlies their whole fabric also, we naturally go first of all to the letters of Paul. Their very mass is impressive; and the definiteness with which their composition within a generation of the death of Jesus may be fixed adds importance to them as historical witnesses. Certainly they leave

nothing to be desired in the richness of their testimony to the Trinitarian conception of God which underlies them. Throughout the whole series, from 1 Thess, which comes from about 52 AD, to 2 Tim, which was written about 68 AD, the redemption, which it is their one business to proclaim and commend, and all the blessings which enter into it or accompany it are referred consistently to a threefold Divine causation. Everywhere, throughout their pages, God the Father, the Lord Jesus Christ, and the Holy Spirit appear as the joint objects of all religious adoration, and the conjunct source of all Divine operations. In the freedom of the allusions which are made to them, now and again one alone of the three is thrown up into prominent view; but more often two of them are conjoined in thanksgiving or prayer; and not infrequently all three are brought together as the apostle strives to give some adequate expression to his sense of indebtedness to the Divine source of all good for blessings received, or to his longing on behalf of himself or of his readers for further communion with the God of grace. It is regular for him to begin his Epp. with a prayer for "grace and peace" for his readers, "from God our Father, and the Lord Jesus Christ," as the joint source of these Divine blessings by way of eminence (Rom 1 7; 1 Cor 1 3; 2 Cor 1 2; Gal 1 3; Eph 1 2; Phil 1 2; 2 Thess 1 2; 1 Tim 1 2; 2 Tim 1 2; Philem ver 3; cf 1 Thess 1 1). It is obviously no departure from this habit in the essence of the matter, but only in relative fulness of expression, when in the opening words of the Ep. to the Col, the clause "and the Lord Jesus Christ" is omitted, and we read merely: "Grace to you and peace from God our Father." So also it would have been no departure from it in the essence of the matter, but only in relative fulness of expression, if in any instance the name of the Holy Spirit had chanced to be adjoined to the other two, as in the single instance of 2 Cor 13 14 it is adjoined to them in the closing prayer for grace with which Paul ends his letters, and which ordinarily takes the simple form of, "the grace of our Lord Jesus Christ be with you" (Rom 16 20; 1 Cor 16 23; Gal 6 18; Phil 4 23; 1 Thess 5 28; 2 Thess 3 18; Philem ver 25; more expanded form, Eph 6 23,24; more compressed, Col 4 18; 1 Tim 6 21; 2 Tim 4 22; Tit 3 15). Between these opening and closing passages the allusions to God the Father, the Lord Jesus Christ, and the Holy Spirit are constant and most intricately interlaced. Paul's monotheism is intense: the first premise of all his thought on Divine things is the unity of God (Rom 3 30; 1 Cor 8 4; Gal 3 20; Eph 4 6; 1 Tim 2 5; cf Rom 16 22; 1 Tim 1 17). Yet to him God the Father is no more God than the Lord Jesus Christ is God, or the Holy Spirit is God. The Spirit of God is to him related to God as the spirit of man is to man (1 Cor 2 11), and therefore if the Spirit of God dwells in us, that is God dwelling in us (Rom 8 10 ff), and we are by that fact constituted temples of God (1 Cor 3 16). And no expression is too strong for him to use in order to assert the Godhead of Christ: He is "our great God" (Tit 2 13); He is "God over all" (Rom 9 5); and indeed it is expressly declared of Him that the "fulness of the Godhead," that is, everything that enters into Godhead and constitutes it Godhead, dwells in Him. In the very act of asserting his monotheism Paul takes Our Lord up into this unique Godhead. "There is no God but one," he roundly asserts, and then illustrates and proves this assertion by remarking that the heathen may have "gods many, and lords many," but "to us there is one God, the Father, of whom are all things, and we unto him; and one Lord, Jesus Christ, through whom are all things, and we through him" (1 Cor

8 6). Obviously, this "one God, the Father," and "one Lord, Jesus Christ," are embraced together in the one God who alone is. Paul's conception of the one God, whom alone he worships, includes, in other words, a recognition that within the unity of His Being, there exists such a distinction of Persons as is given us in the "one God, the Father" and the "one Lord, Jesus Christ."

In numerous passages scattered through Paul's Epp., from the earliest of them (1 Thess 1 2-5; 2 Thess 2 13,14) to the latest (Tit 3 4-6; 2 Tim 1 3,13,14), all three Persons, God the Father, the Lord Jesus Christ and the Holy Spirit, are brought together, in the most incidental manner, as co-sources of all the saving blessings which come to believers in Christ. A typical series of such passages may be found in Eph 2 18; 3 2-5,14,17; 4 4-6; 5 18-20. But the most interesting instances are offered to us perhaps by the Epp. to the Cor. In 1 Cor 12 4-6 Paul presents the abounding spiritual gifts with which the church was blessed in a threefold aspect, and connects these aspects with the three Divine Persons. "Now there are diversities of gifts, but the same Spirit. And there are diversities of ministrations, and the same Lord. And there are diversities of workings, but the same God, who worketh all things in all." It may be thought that there is a measure of what might almost be called artificiality in assigning the endowments of the church, as they are graces to the Spirit, as they are services to Christ, and as they are energizings to God. But thus there is only the more strikingly revealed the underlying Trinitarian conception as dominating the structure of the clauses: Paul clearly so writes, not because "gifts," "workings," "operations" stand out in his thought as greatly diverse things, but because God, the Lord, and the Spirit lie in the back of his mind constantly suggesting a threefold causality behind every manifestation of grace. The Trinity is alluded to rather than asserted; but it is so alluded to as to show that it constitutes the determining basis of all Paul's thought of the God of redemption. Even more instructive is 2 Cor 13 14, which has passed into general liturgical use in the churches as a benediction: "The grace of the Lord Jesus Christ, and the love of God, and the communion of the Holy Spirit, be with you all." Here the three highest redemptive blessings are brought together, and attached distributively to the three Persons of the Triune God. There is again no formal teaching of the doctrine of the Trinity; there is only another instance of natural speaking out of a Trinitarian consciousness. Paul is simply thinking of the Divine source of these great blessings; but he habitually thinks of this Divine source of redemptive blessings after a trinal fashion. He therefore does not say, as he might just as well have said, "The grace and love and communion of God be with you all," but "The grace of the Lord Jesus Christ, and the love of God, and the communion of the Holy Spirit, be with you all." Thus he bears, almost unconsciously but most richly, witness to the trinal composition of the Godhead as conceived by Him.

The phenomena of Paul's Epp. are repeated in the other writings of the NT. In these other writings also it is everywhere assumed that the redemptive activities of God rest on a threefold source in God the Father, the Lord Jesus Christ, and the Holy Spirit; and these three Persons repeatedly come forward together in the expressions of Christian hope or the aspirations of Christian devotion (e.g. He 2 3,4; 6 4-6; 10 29-31; 1 Pet 1 2; 2 3-12; 4 13-19; 1 Jn 5 4-8; Jude vs 20,21; Rev 1 4-6). Perhaps as typical

instances as any are supplied by the two following: "According to the foreknowledge of God the Father, in sanctification of the Spirit, unto obedience and sprinkling of the blood of Jesus Christ" (1 Pet 1 2); "Praying in the Holy Spirit, keep yourselves in the love of God, looking for the mercy of our Lord Jesus Christ unto eternal life" (Jude vs 20,21). To these may be added the highly symbolical instance from the Apocalypse: 'Grace to you and peace from Him which is and was and which is to come; and from the Seven Spirits which are before His throne; and from Jesus Christ, who is the faithful witness, the firstborn of the dead, and the ruler of the kings of the earth' (Rev 1 4,5). Clearly these writers, too, write out of a fixed Trinitarian consciousness and bear their testimony to the universal understanding current in apostolical circles. Everywhere and by all it was fully understood that the one God whom Christians worshipped and from whom alone they expected redemption and all that redemption brought with it, included within His undiminished unity the three: God the Father, the Lord Jesus Christ, and the Holy Spirit, whose activities relatively to one another are conceived as distinctly personal. This is the uniform and pervasive testimony of the NT, and it is the more impressive that it is given with such unstudied naturalness and simplicity, with no effort to distinguish between what have come to be called the ontological and the economical aspects of the Trinitarian distinctions, and indeed without apparent consciousness of the existence of such a distinction of aspects. Whether God is thought of in Himself or in His operations, the underlying conception runs unaffectedly into trinal forms.

It will not have escaped observation that the Trinitarian terminology of Paul and the other writers of the NT is not precisely identical with that of Our Lord as recorded for us in His discourses. Nomenclature Paul, for example—and the same is true of the other NT writers (except John)—does not speak, as Our Lord is recorded as speaking, of the Father, the Son, and the Holy Spirit, so much as of God, the Lord Jesus Christ, and the Holy Spirit. This difference of terminology finds its account in large measure in the different relations in which the speakers stand to the Trinity. Our Lord could not naturally speak of Himself, as one of the Trinitarian Persons, by the designation of "the Lord," while the designation of "the Son," expressing as it does His consciousness of close relation, and indeed of exact similarity, to God, came naturally to His lips. But He was Paul's Lord; and Paul naturally thought and spoke of Him as such. In point of fact, "Lord" is one of Paul's favorite designations of Christ, and indeed has become with him practically a proper name for Christ, and in point of fact, his Divine Name for Christ. It is naturally, therefore, his Trinitarian name for Christ. Because when he thinks of Christ as Divine he calls Him "Lord," he naturally, when he thinks of the three Persons together as the Triune God, sets Him as "Lord" by the side of God—Paul's constant name for "the Father"—and the Holy Spirit. Question may no doubt be raised whether it would have been possible for Paul to have done this, esp. with the constancy with which he has done it, if, in his conception of it, the very essence of the Trinity were enshrined in the terms "Father" and "Son." Paul is thinking of the Trinity, to be sure, from the point of view of a worshipper, rather than from that of a systematizer. He designates the Persons of the Trinity therefore rather from his relations to them than from their relations to one another. He sees in the Trinity his God, his Lord, and the Holy Spirit who dwells

16. Conjunction of the Three in Paul

18. Variations in Nomenclature

in him; and naturally he so speaks currently of the three Persons. It remains remarkable, nevertheless, if the very essence of the Trinity were thought of by him as resident in the terms "Father," "Son," that in his numerous allusions to the Trinity in the Godhead, he never betrays any sense of this. It is noticeable also that in their allusions to the Trinity, there is preserved, neither in Paul nor in the other writers of the NT, the order of the names as they stand in Our Lord's great declaration (Mt 28 19). The reverse order occurs, indeed, occasionally, as, for example, in 1 Cor 12 4-6 (cf Eph 4 4-6); and this may be understood as a climactic arrangement and so far a testimony to the order of Mt 28 19. But the order is very variable; and in the most formal enumeration of the three Persons, that of 2 Cor 13 14, it stands thus: Lord, God, Spirit. The question naturally suggests itself whether the order Father, Son, Spirit was esp. significant to Paul and his fellow-writers of the NT. If in their conviction the very essence of the doctrine of the Trinity was embodied in this order, should we not anticipate that there should appear in their numerous allusions to the Trinity some suggestion of this conviction?

Such facts as these have a bearing upon the testimony of the NT to the interrelations of the Persons of the Trinity. To the fact of the Trinity—to the fact, that is, that

**19. Implications of "Son" and "Spirit"** in the unity of the Godhead there subsist three Persons, each of whom has his particular part in the working out of salvation—the NT testimony is

clear, consistent, pervasive and conclusive. There is included in this testimony constant and decisive witness to the complete and undiminished Deity of each of these Persons; no language is too exalted to apply to each of them in turn in the effort to give expression to the writer's sense of His Deity: the name that is given to each is fully understood to be "the name that is above every name." When we attempt to press the inquiry behind the broad fact, however, with a view to ascertaining exactly how the NT writers conceive the three Persons to be related, the one to the other, we meet with great difficulties. Nothing could seem more natural, for example, than to assume that the mutual relations of the Persons of the Trinity are revealed in the designations, "the Father, the Son, and the Holy Spirit," which are given them by Our Lord in the solemn formula of Mt 28 19. Our confidence in this assumption is somewhat shaken, however, when we observe, as we have just observed, that these designations are not carefully preserved in their allusions to the Trinity by the writers of the NT at large, but are characteristic only of Our Lord's allusions and those of John, whose modes of speech in general very closely resemble those of Our Lord. Our confidence is still further shaken when we observe that the implications with respect to the mutual relations of the Trinitarian Persons, which are ordinarily derived from these designations, do not so certainly lie in them as is commonly supposed.

It may be very natural to see in the designation "Son" an intimation of subordination and derivation of Being, and it may not be difficult to ascribe a similar connotation to the term "Spirit." But it is quite certain that this was not the denotation of either term in the Sem consciousness, which underlies the phraseology of Scripture; and it may even be thought doubtful whether it was included even in their remoter suggestions. What underlies the conception of sonship in Scriptural speech is just "likeness"; whatever the father is that the son is also. The emphatic application of the term "Son" to one of the Trinitarian Persons, accordingly,

asserts rather His equality with the Father than His subordination to the Father; and if there is any implication of derivation in it, it would appear to be very distant. The adjunction of the adjective "only begotten" (Jn 1 14; 3 16-18; 1 Jn 4 9) need add only the idea of uniqueness, not of derivation (Ps 22 21; 25 16; 35 17; Wisd 7 22m); and even such a phrase as "God only begotten" (Jn 1 18m) may contain no implication of derivation, but only of absolutely unique consubstantiality; as also such a phrase as 'the first-begotten of all creation' (Col 1 15) may convey no intimation of coming into being, but merely assert priority of existence. In like manner, the designation "Spirit of God" or "Spirit of Jeh," which meets us frequently in the OT, certainly does not convey the idea there either of derivation or of subordination, but is just the executive name of God—the designation of God from the point of view of His activity—and imports accordingly identity with God; and there is no reason to suppose that, in passing from the OT to the NT, the term has taken on an essentially different meaning. It happens, oddly enough, moreover, that we have in the NT itself what amounts almost to formal definitions of the two terms "Son" and "Spirit," and in both cases the stress is laid on the notion of equality or sameness. In Jn 5 18 we read: 'On this account, therefore, the Jews sought the more to kill him, because, not only did he break the Sabbath, but also called God his own Father, making himself equal to God.' The point lies, of course, in the adj. "own." Jesus was, rightly, understood to call God 'his own Father,' that is, to use the terms "Father" and "Son" not in a merely figurative sense, as when Israel was called God's son, but in the real sense. And this was understood to be claiming to be all that God is. To be the Son of God in any sense was to be like God in that sense; to be God's own Son was to be exactly like God, to be "equal with God." Similarly, we read in 1 Cor 2 10.11: 'For the Spirit searcheth all things, yea, the deep things of God. For who of men knoweth the things of a man, save the spirit of man which is in him? Even so the things of God none knoweth, save the Spirit of God.' Here the Spirit appears as the substrate of the Divine self-consciousness, the principle of God's knowledge of Himself: He is, in a word, just God Himself in the innermost essence of His Being. As the spirit of man is the seat of human life, the very life of man itself, so the Spirit of God is His very life-element. How can He be supposed, then, to be subordinate to God, or to derive His Being from God? If, however, the subordination of the Son and Spirit to the Father in modes of subsistence and their derivation from the Father are not implicates of their designation as Son and Spirit, it will be hard to find in the NT compelling evidence of their subordination and derivation.

There is, of course, no question that in "modes of operation," as it is technically called—that is to say, in the functions ascribed to the several Persons of the Trinity in the redemptive process, and, more broadly, in the entire dealing of God with the world—the principle of subordination is clearly expressed. The Father is first, the Son is second, and the Spirit is third, in the operations of God as revealed to us in general, and very esp. in those operations by which redemption is accomplished. Whatever the Father does, He does through the Son (Rom 2 16; 3 22; 5 1.11.17.21; Eph 1 5; 1 Thess 5 9; Tit 3 5) by the Spirit. The Son is sent by the Father and does His Father's will (Jn 6 38); the Spirit is sent by the Son and does not speak from Himself, but only takes of Christ's and shows it unto His people (Jn 17 7f); and we have Our Lord's own word for it that 'one that is sent is not greater than he that sent him' (Jn 13 16). In crisp decisiveness, Our Lord even declares, indeed: 'My Father is greater than I' (Jn 14 28); and Paul tells us that Christ is God's, even as we are Christ's (1 Cor 3 23), and that as Christ is "the head of every man," so God is "the head

## 20. The Question of Subordination



of Christ" (1 Cor 11 3). But it is not so clear that the principle of subordination rules also in "modes of subsistence," as it is technically phrased; that is to say, in the necessary relation of the Persons of the Trinity to one another. The very richness and variety of the expression of their subordination, the one to the other, in modes of operation, create a difficulty in attaining certainty whether they are represented as also subordinate the one to the other in modes of subsistence. Question is raised in each case of apparent intimation of subordination in modes of subsistence, whether it may not, after all, be explicable as only another expression of subordination in modes of operation. It may be natural to assume that a subordination in modes of operation rests on a subordination in modes of subsistence; that the reason why it is the Father that sends the Son and the Son that sends the Spirit is that the Son is subordinate to the Father, and the Spirit to the Son. But we are bound to bear in mind that these relations of subordination in modes of operation may just as well be due to a convention, an agreement, between the Persons of the Trinity—a "Covenant" as it is technically called—by virtue of which a distinct function in the work of redemption is voluntarily assumed by each. It is eminently desirable, therefore, at the least, that some definite evidence of subordination in modes of subsistence should be discoverable before it is assumed. In the case of the relation of the Son to the Father, there is the added difficulty of the incarnation, in which the Son, by the assumption of a creaturely nature into union with Himself, enters into new relations with the Father of a definitely subordinate character. Question has even been raised whether the very designations of Father and Son may not be expressive of these new relations, and therefore without significance with respect to the eternal relations of the Persons so designated. This question must certainly be answered in the negative. Although, no doubt, in many of the instances in which the terms "Father" and "Son" occur, it would be possible to take them of merely economical relations, there ever remain some which are intractable to this treatment, and we may be sure that "Father" and "Son" are applied to their eternal and necessary relations. But these terms, as we have seen, do not appear to imply relations of first and second, superiority and subordination, in modes of subsistence; and the fact of the humiliation of the Son of God for His earthly work does introduce a factor into the interpretation of the passages which import His subordination to the Father, which throws doubt upon the inference from them of an eternal relation of subordination in the Trinity itself. It must at least be said that in the presence of the great NT doctrines of the Covenant of Redemption on the one hand, and of the Humiliation of the Son of God for His work's sake and of the Two Natures in the constitution of His Person as incarnated, on the other, the difficulty of interpreting subordinationist passages of eternal relations between the Father and Son becomes extreme. The question continually obtrudes itself, whether they do not rather find their full explanation in the facts embodied in the doctrines of the Covenant, the Humiliation of Christ, and the Two Natures of His incarnated Person. Certainly in such circumstances it were thoroughly illegitimate to press such passages to suggest any subordination for the Son or the Spirit which would in any manner impair that complete identity with the Father in Being and that complete equality with the Father in powers which are constantly presupposed, and frequently emphatically, though only incidentally, asserted for them throughout the whole fabric of the NT.

The Trinity of the Persons of the Godhead, shown in the incarnation and the redemptive work of God the Son, and the descent and saving  
**21. Witness work of God the Spirit, is thus everywhere assumed in the NT, and comes to repeated fragmentary but none the less emphatic and illuminating expression in its pages. As the roots of its revelation are set in the threefold**

Divine causality of the saving process, it naturally finds an echo also in the consciousness of everyone who has experienced this salvation. Every redeemed soul, knowing himself reconciled with God through His Son, and quickened into newness of life by His Spirit, turns alike to Father, Son and Spirit with the exclamation of reverent gratitude upon his lips, "My Lord and my God!" If he could not construct the doctrine of the Trinity out of his consciousness of salvation, yet the elements of his consciousness of salvation are interpreted to him and reduced to order only by the doctrine of the Trinity which he finds underlying and giving their significance and consistency to the teaching of the Scriptures as to the processes of salvation. By means

of this doctrine he is able to think clearly and consequently of his threefold relation to the saving God, experienced by him as Fatherly love sending a Redeemer, as redeeming love executing redemption, as saving love applying redemption: all manifestations in distinct methods and by distinct agencies of the one seeking and saving love of God. Without the doctrine of the Trinity, his conscious Christian life would be thrown into confusion and left in disorganization if not, indeed, given an air of unreality; with the doctrine of the Trinity, order, significance and reality are brought to every element of it. Accordingly, the doctrine of the Trinity and the doctrine of redemption, historically, stand or fall together. A Unitarian theology is commonly associated with a Pelagian anthropology and a Socinian soteriology. It is a striking testimony which is borne by E. Koenig (*Offenbarungsbegriff des AT*, 1882, I, 125): "I have learned that many cast off the whole history of redemption for no other reason than because they have not attained to a conception of the Triune God." It is in this intimacy of relation between the doctrines of the Trinity and redemption that the ultimate reason lies why the Christian church could not rest until it had attained a definite and well-compacted doctrine of the Trinity. Nothing else could be accepted as an adequate foundation for the experience of the Christian salvation. Neither the Sabellian nor the Arian construction could meet and satisfy the data of the consciousness of salvation, any more than either could meet and satisfy the data of the Scriptural revelation. The data of the Scriptural revelation might, to be sure, have been left unsatisfied: men might have found a *modus vivendi* with neglected, or even with perverted Scriptural teaching. But perverted or neglected elements of Christian experience are more clamant in their demands for attention and correction. The dissatisfied Christian consciousness necessarily searched the Scriptures, on the emergence of every new attempt to state the doctrine of the nature and relations of God, to see whether these things were true, and never reached contentment until the Scriptural data were given their consistent formulation in a valid doctrine of the Trinity. Here too the heart of man was restless until it found its rest in the Triune God, the author, procurer and applier of salvation.

The determining impulse to the formulation of the doctrine of the Trinity in the church was the church's profound conviction of the absolute Deity of Christ, on which as on a pivot the whole Christian conception of God from the first origins of Christianity turned. The guiding principle in the formulation of the doctrine was supplied by the Baptismal Formula announced by Jesus (Mt 28 19), from which was derived the ground-plan of the baptismal confessions and "rules of faith" which very soon began to be framed all over the church. It was by these two fundamental *principia*—the true Deity of Christ and the Baptismal Formula—that all attempts to formulate the Christian doctrine of God were tested, and by their molding power that the church at length found itself in possession of a form of statement which did full justice to the data of the redemptive revelation as reflected in the NT and the demands of the Christian heart under the experience of salvation.

In the nature of the case the formulated doctrine was of slow attainment. The influence of inherited conceptions and of current philosophies inevitably showed itself in the efforts to construe to the intellect the immanent faith of Christians. In the 2d cent. the dominant neo-Stoic and neo-Platonic ideas deflected Christian thought into subordinationist channels, and produced what is known as the Logos-Christology, which looks upon the Son as a prolation of Deity reduced to such dimensions as comported with relations with a world of

time and space; meanwhile, to a great extent, the Spirit was neglected altogether. A reaction which, under the name of Monarchianism, identified the Father, Son, and Spirit so completely that they were thought of only as different aspects or different moments in the life of the one Divine Person, called now Father, now Son, now Spirit, as His several activities came successively into view, almost succeeded in establishing itself in the 3d cent. as the doctrine of the church at large. In the conflict between these two opposite tendencies the church gradually found its way, under the guidance of the Baptismal Formula elaborated into a "Rule of Faith," to a better and more well-balanced conception, until a real doctrine of the Trinity at length came to expression, particularly in the West, through the brilliant dialectic of Tertullian. It was thus ready at hand, when, in the early years of the 4th cent., the Logos-Christology, in opposition to dominant Sabellian tendencies, ran to seed in what is known as Arianism, to which the Son was a creature, though exalted above all other creatures as their Creator and Lord; and the church was thus prepared to assert its settled faith in a Triune God, one in being, but in whose unity there subsisted three consubstantial Persons. Under the leadership of Athanasius this doctrine was proclaimed as the faith of the church at the Council of Nice in 325 A.D. and by his strenuous labors and those of "the three great Cappadocians," the two Gregories and Basil, it gradually won its way to the actual acceptance of the entire church. It was at the hands of Augustine, however, a century later, that the doctrine thus become the church doctrine in fact as well as in theory, received its most complete elaboration and most carefully grounded statement. In the form which he gave it, and which is embodied in that "battle-hymn of the early church," the so-called Athanasian Creed, it has retained its place as the fit expression of the faith of the church as to the nature of its God until today. The language in which it is couched, even in this final declaration, still retains elements of speech which owe their origin to the modes of thought characteristic of the Logos-Christology of the 2d cent., fixed in the nomenclature of the church by the Nicene Creed of 325 A.D. though carefully guarded there against the subordinationism inherent in the Logos-Christology, and made the vehicle rather of the Nicene doctrines of the eternal generation of the Son and procession of the Spirit, with the consequent subordination of the Son and Spirit to the Father in modes of subsistence as well as of operation. In the Athanasian Creed, however, the principle of the equalization of the three Persons, which was already the dominant motive of the Nicene Creed—the *homouistia*—is so strongly emphasized as practically to push out of sight, if not quite out of existence, these remnant suggestions of derivation and subordination. It has been found necessary, nevertheless, from time to time, vigorously to reassert the principle of equalization, over against a tendency unduly to emphasize the elements of the subordinationism which still hold a place thus in the traditional language in which the church states its doctrine of the Trinity. In particular, it fell to Calvin, in the interests of the true Deity of Christ—the constant motive of the whole body of Trinitarian thought—to reassert and make good the attribute of self-existence (*autotheotês*) for the Son. Thus Calvin takes his place, alongside of Tertullian, Athanasius and Augustine, as one of the chief contributors to the exact and vital statement of the Christian doctrine of the Triune God.

LITERATURE.—F. C. Baur, *Die christliche Lehre von der Dreieinigkeit Gottes*, 3 vols., Tübingen, 1841-43; Dionysius Petavius, *De Trinitate* (vol. II, of *De Theologicis Dogmaticis*, Paris, 1647); G. Bull, *A Defence of the Nicene Creed* (1685), 2 vols., Oxford, 1851; G. S. Faber, *The Apostolicity of Trinitarianism*, 2 vols., 1832; Augustine, *On the Holy Trinity* (vol. III of *Nicene and Post-Nicene Fathers of the Christian Church*, 1-228), New York, 1887; Calvin, *Institutes of the Christian Religion*, I, ch. xiii.; C. Hodge, *Systematic Theology and Index*, I, New York, 1873, 442-82; H. Bavinck, *Geformeerde Dogmatiek*, II, Kampen, 1908, 260-347 (gives excellent references to literature); S. Harris, *God, Creator, and Lord of All*, New York, 1896; R. Rocholl, *Der christliche Gottesbegriff*, Göttingen, 1900; W. F. Adeney, *The Christian Conception of God*, London, 1909, 215-46; J. Lebreton, *Les origines du dogme de la Trinité*, Paris, 1910; J. C. K. Hofmann, *Der Schriftbeweis*, Nördlingen, 1857-60, I, 85-111; J. L. S. Lutz, *Biblische Dogmatik*, Pforzheim, 1817, 319-94; R. W. Landis, *A Plea for the Catholic Doctrine of the Trinity*, Philadelphia, 1832; E. H. Bickersteth, *The Rock of Ages*, etc., London, 1866; New York, 1891; E. Riggenbach, "Der trinitarische Taufbefehl, Mt 28 19" (in *Schatter and Cremer, Beiträge zur Förderung christlicher Theologie*, 1903, VII; also 1906, X); F. J. Hall, *The Trinity*, London and New York, 1910, 100-141; J. Pearson, *An Exposition of the Creed*, ed Chevallier and Sinker, Cambridge, 1899; J. Howe, "Calm Discourse on the Trinity," in *Works*, ed Hunt, London, 1810-22; J. Owen, "Vindication of the Doctrine of the Holy Trinity," and "Saint's Fellowship with the Trinity," in *Works*, Gould's ed., London, 1850-55; J. Edwards, *Observations concerning the Scripture Economy of the Trinity*, etc., New York, 1880, also *An Unpublished Essay on the Trinity*, New York, 1903; J. R. Illingworth, *The Doctrine of the Trinity*

*Apologetically Considered*, London and New York, 1907; A. F. W. Ingram, *The Love of the Trinity*, New York, 1908.

[NOTE.—In this art. the author has usually given his own renderings of original passages, and not those of any particular VS.—EDITORS.]

BENJAMIN B. WARFIELD

TRIPOLIS, trip'ô-lis (Τρίπολις, *Trîpolis*, "triple city"): Demetrius the son of Seleucus, having fled from Rome, collected "a mighty host and fleet," sailed into the haven of Tripolis, took the city, obtained possession of the country, and put to death his cousin, Antiochus V, along with his guardian Lysias (2 Macc 14 1 ff; Jos, *Ant*, XII, x, 1). After a period of unsuccessful guerrilla warfare against Hyrcanus in Samaria, Antiochus Cyzicenus retired to Tripolis (*Ant*, XII, x, 2). The city was founded by the Phoenicians and was a member of the Phoen league. It was divided into 3 quarters by walls—hence the name "triple city"—and these were occupied by settlers from Tyre, Sidon, and Aradus, respectively. The federal council of these states sat here. Its position on the Phoen seacoast, with easy access to the interior, gave it many advantages from the commercial point of view. The Seleucid monarchs, the Romans, and Herod the Great did much to beautify the city; the last-named building a gymnasium (Jos, *BJ*, I, xxi, 11). When attacked by the Arabs the inhabitants took ship and escaped. Later their places were taken by Jews and Persians. Captured by the Crusaders in 1109, it was taken by the Egyptians in 1289. The ancient city was surrounded on three sides by the sea. The site is now occupied by *el-Mina*, the harbor of the modern city, *Tarâbulûs*, which stands on the bank of *Nahr Kadîsha*, about 2 miles away. The inhabitants number about 23,000. The town gives its name to a district under the *vilâyet* of Beirut, which has always been famous for its fruitfulness. W. EWING

TRIUMPH, trî'umf (θριαμβεύω, *thriambeûô*, "to lead in triumph"): The word is used by Paul to express an idea very familiar to antiquity, and to the churches at Corinth and Colossæ: "But thanks be unto God, who always leadeth us in triumph in Christ" (2 Cor 2 14); "Having spoiled the principalities and the powers, he made a show of them openly, triumphing over them in it" (Col 2 15).

A triumph in Rome was a magnificent procession in honor of a victorious general, and the highest military distinction which he could obtain. It was granted by the senate only to one who had held the office of dictator, consul, or praetor, and after a decisive victory in the complete subjugation of a province. In a Rom triumph the victorious general entered the city in a chariot drawn by four horses. He was crowned with laurel, having a scepter in one hand and a branch of laurel in the other. He was preceded by the senate and magistrates, musicians, the spoils of his victory, and the captives in fetters; and followed by his army on foot, in marching order. The procession thus advanced along the Via Sacra to the Capitol, where a bull was sacrificed to Jupiter, and the laurel wreath deposited in the lap of the god. During the triumphal entry the priests burned incense, and hence the reference of the apostle: "For we are a sweet savor of Christ unto God, in them that are saved, and in them that perish; to the one a savor from death unto death; to the other a savor from life unto life" (2 Cor 2 15 16). The incense that was to the victor the "savor" of his triumph would be to the wretched captives the "savor," or intimation, of a rapidly approaching death in the Rom arena or in the damp vaults of the Tullianum. Thus the "incense," or influence, of the apostolic gospel would be to the believer the

assurance of redemption through Christ, and to the unbeliever the assurance of spiritual death.

After the suicide of Antony in Alexandria (30 BC) Augustus Caesar succeeded in getting Cleopatra into his power. She had hoped to subdue him by her charms, but without avail. Aware that she was doomed, she revolted against the thought of being led in triumph to Rome, and, as tradition states, took her own life by allowing an asp to bite her, saying, "I will not be led in triumph"; see Shakespeare's *Antony and Cleopatra*, V, ii:

"He'll lead me, then, in triumph? . . .  
Thou, an Egyptian puppet, shalt be shown  
In Rome as well as I: mechanic slaves,  
With greasy aprons, rules, and hammers shall  
Uplift us to the view. . . ."

ARTHUR WALWYN EVANS

**TROAS**, trō'as (Τροάς, *Trōás*): The chief city in the N.W. of Asia Minor, on the coast of Mysia in the Rom province of Asia. From here, according to Acts 16 8, Paul sailed. Here, also, according to Acts 20 5-12, Paul raised Eutychus from the dead. The name Troas was not confined to the town itself, but it was also applied to the surrounding district, or to that part of the coast which is now generally known as the Troad. In its early history it bore the name of Antigonā Troas, which was given it by its founder Antigonus, but after 300 BC it was generally known to the classical writers as Alexander Troas, a name given to it by Lysimachus. For a time the Seleucid kings made their homes at Troas. Later, when the city became free, it struck its own coins, of which vast numbers are found; a common type is one upon which is stamped a grazing horse. In 133 BC Troas came into the possession of the Romans, and later, during the reign of Augustus, it was made a Rom *colonia*, independent of the Rom governor of the province of Asia. Its citizens were then exempt from poll and land tax. During Byzantine times Troas was the seat of a bishopric.

The ruins of Troas, now bearing the name of *Eski Stambul*, are extensive, giving evidence of the great size and importance of the ancient city. They have, however, long been used as a quarry, and the columns of the public buildings were taken to Constantinople for use in the construction of the mosque known as the *Yeni Valideh Jami*. The site is now mostly overgrown with oaks, but from the higher portions of the ruins there is an extensive view over the sea and the neighboring islands. It is only with difficulty that one may now trace the city walls and locate the square towers which flanked them at intervals. Within the walls are the remains of the theater, the temple and the gymnasium, which was provided with baths. The port from which Paul sailed was constructed by means of a mole, with an outer and an inner basin. The most imposing of the ruins, however, is a large aqueduct which was built in the time of Trajan. E. J. BANKS

**TROGYLLIUM**, trō-jil'i-um, trō-gil'i-um (Τρογύλλιον, *Trogýllion*): According to Acts 20 15 AV, ARV<sup>m</sup>, the ship in which Paul sailed to Caesarea on his return from his 3d missionary journey tarried at Trogyllium. Several of the early MSS omit the words, "tarried at Trogyllium" (WH omits as "Western" interpolation); yet, whether the words belonged to the text or not, Paul evidently passed the promontory, and probably stopped there. From the coast near Miletus the promontory projects into the sea toward the island of Samos; the strait separating the mainland from the island is scarcely a mile wide. It was in this strait which is now called *Kutchuk Boghaz* by the Turks that the battle of Mycale was fought in 479 BC. The promontory now bears the name of Santa Maria, and the place of anchorage is called Saint Paul's port. E. J. BANKS

**TROOP**, trōōp. See ARMY.

**TROPHIMUS**, trof'i-mus (Τρόφιμος, *Trōphimos*, lit. "a foster child" [Acts 20 4; 21 29; 2 Tim 4 20]): An Asiatic Christian, a friend and companion-in-travel of the apostle Paul.

In the first of the three passages in which Trophimus is mentioned, he and Tychicus are called *Asianoi*, that is, natives of the Rom province of Asia; and making it still more definite, in Acts 21 29, he is termed an "Ephesian." T. was one of eight friends, who accompanied Paul at the close of his 3d missionary journey, and traveled with him from Greece through Macedonia into Asia, and onward by sea until Jerus was reached (see TYCHICUS). T. went with Paul all the way, for, in the second of the passages referred to, he is mentioned as being with Paul in Jerus immediately on the close of this journey.

He was the innocent cause of Paul being assaulted in the courts of the temple by the Jewish mob, and then of his being arrested and imprisoned by the Romans. The occasion of this outrage was that the Jews supposed that Paul had "brought Greeks also into the temple, and . . . defiled this holy place" (Acts 21 28). The modicum of fact lying at the root of this false accusation was that they had seen Paul and T. in each other's company in the city. On this slender basis "they supposed" that Paul had brought T. past the barrier or middle wall of partition (Eph 2 14; see PARTITION), beyond which no Gentile was allowed to penetrate on pain of death. They supposed that T., who was neither a Jew nor a proselyte, but a gentile Christian, had been introduced into the temple itself by Paul—which would have been profanation. Hence their fury against the apostle.

How strongly they insisted on the crime which Trophimus was falsely alleged to have committed on that occasion, is seen again in the way in which the orator Tertullus repeated the charge against Paul before the Rom governor Felix, "who moreover assayed to profane the temple" (Acts 24 6).

The third reference to T. is in 2 Tim 4 20, "Trophimus I left at Miletus sick." This final notice shows that he was again—several

years after the date indicated in the previous passages—traveling with Paul on one of the missionary journeys which the apostle undertook after being liberated from his first imprisonment in Rome. It is exceedingly difficult, perhaps impossible, to trace the course of the different journeys which Paul now made, as there is no such narrative as is given in Acts for the former journeys, but merely incidental notices of his later travels, in the Pastoral Epp. In this, the last of all his letters—2 Tim—Paul indicates various places which he had visited, and also the names of friends who traveled with him on this the last of his apostolic journeys.

Among other places, he had visited Miletus, a city on the coast of the province of Asia; and there his old friend T. had been laid down with illness, so severe that he could travel no farther, but Paul left him "at Miletus sick." It is to be noted that Miletus was not far from Ephesus, which was T.'s native city. There would be much intercourse between the two cities (see Acts 20 17, where Paul sends for the elders of the church at Ephesus to come to him at Miletus, which they did). T., therefore, in his sickness, could easily reach Ephesus, or his friends from that city could quickly come to him at Miletus, and give him whatever attention and nursing he might require.

It has been conjectured that T. is to be identified with the person mentioned in 2 Cor 8 16-24. Paul there speaks in the highest terms of one of his companions—but without giving his name—whom

he sent with Titus. Titus and this disciple were evidently those to whose care Paul intrusted the carrying of the Second Ep. to the Cor to its destination. The apostle **4. The Description** says of this unnamed brother, not only **2 Cor 8:18** that his praise is in the gospel throughout all the churches, but also that he was chosen by the churches to travel with him, i.e. with Paul, with this grace, i.e. with the contribution of money collected in the gentile churches for the poor saints in Jerus.

Now it is certain that at the close of his 3d missionary journey Paul carried these gifts to Jerus ("I came to bring alms to my nation, and offerings," Acts 24 17); and some of the eight friends who accompanied him on the journey (20 4) were those who had been intrusted by the churches with the safe conveyance of the money. Speaking of these collections, Paul writes (1 Cor 16 3-4), "Whomsoever ye shall approve, them will I send with letters to carry your bounty unto Jerus: and if it be meet for me to go also, they shall go with me." These conditions were fulfilled, when Paul and his eight friends traveled from Greece to Jerus, carrying the money with them. There is therefore certainty that one of the eight is the brother referred to in 2 Cor 8 18, whose praise in the gospel was in all the churches, and whom the churches had appointed to travel with Paul for the purpose of carrying the money contribution, and whom Paul had "many times proved earnest in many things" (2 Cor 8 18,19,22). The eight were Sopater of Bereoa, Aristarchus and Secundus, both from Thessalonica, Gaius of Derbe, Timothy, Tychicus and T., both "Asians," and lastly Luke.

There is certainly the possibility that the unnamed brother was T.: if not T., then he was one of the other seven. Of these seven, by the process of elimination, the unnamed brother could only be one of those who traveled with Paul the whole distance as far as Jerus, for this was the work which "the brother" had been appointed by the churches to do. Now it is certain that Luke and T. were with him on his arrival in Jerus (Acts 21 17,29). Therefore the brother whose praise in the gospel was in all the churches may very well have been T.: if not T., then possibly Luke or Aristarchus. Gaius and Aristarchus are termed "Paul's companions in travel" (Acts 19 29); and Aristarchus was afterward with Paul in Pal, and sailed with him to Rome. It is quite remarkable that the same word, *συνέκδημος*, *sunékēdēmos*, "companion in travel," is applied to the unnamed brother (2 Cor 8 19), and to Gaius and Aristarchus in Acts 19 29.

As the conditions do not seem to be satisfied in Sopater, Secundus or Timothy, the brother so highly commended must have been either Luke or Gaius or Aristarchus or Tychicus or Trophimus.

JOHN RUTHERFURD

**TROUGH**, trōf. See SHEEP TENDING; BREAD.

**TROW**, trō: An obsolete vb. meaning "to believe"; cf "trust" and the Ger. *trauen*. It occurs only in Lk 17 9, AV "Doth he thank that servant . . . ? I trow not," as a tr of *οὐ δοκῶ*, *ou dokō*, "I believe not." The words *ou dokō*, however, are not part of the original text, but are a later gloss to supply an answer to the question, and hence "I trow not" is omitted by RV.

**TRUCEBREAKER**, trōōs'brāk-ēr: The AV rendering in 2 Tim 3 3 of *ἀσπονδος*, *áspondos*, lit. "without a libation." As a libation always accompanied the making of a treaty in Gr lands, the lack implied that no treaty had been made, or, by a natural extension of meaning, could be made. Hence the word came to mean "implacable" (RV).

**TRUMP**, trump, **TRUMPET**, trum'pet, trum'-pit. See MUSIC.

**TRUMPETS, FEAST OF:** In Lev 23 23-25 the first day (new moon) of the seventh month is set apart as a solemn rest, "a memorial of

**1. Description** blowing of trumpets" (the Heb leaves "of trumpets" to be understood), signalized further by "a holy convocation," abstinence from work, and the presentation of "an offering made by fire." In Nu 29 1-6 these directions are repeated, with a detailed specification of

the nature of the offering. In addition to the usual daily burnt sacrifices and the special offerings for new moons, there are to be offered one bullock, one ram, and seven he-lambs, with proper meal offerings, together with a he-goat for a sin offering.

The significance of the feast lay in the fact that it marked the beginning of the new year according to the older calendar. Originally the "revolution" of the year was reckoned in the fall (Ex 23 16; 34 22), and the change to the spring never thoroughly displaced the older system. In fact the spring New Year never succeeded in becoming a specially recognized feast, and to Jewish ears "New Year's Day"

(*רֵאשִׁית שָׁנָה*, *rō'sh ha-shānāh*) invariably signifies an autumnal festival. So the Mish (*Rō'sh ha-shānāh*, i.1): "There are four periods of commencement of years: On the 1st of Nisan is a new year for kings and for festivals; the 1st of Elul is a new year for the tithe of cattle. . . . The 1st of Tishri is new year's [day] for the ordinary or civil year, for the computation of 7th years, and of the jubilees; also for the planting of trees, and for herbs. On the 1st of Shebat is the new year for trees."

The ritual for the day consequently needs little explanation. All new moons were heralded by trumpeting (Nu 10 10), and so the custom was of course observed on this feast also. There is nothing in the language of either Lev 23 or Nu 29 to require a prolongation of the music on this special new moon, but its special distinction was no doubt marked by special trumpeting at all times, and at a later period (see below) elaborate rules were laid down for this feature. The additional sacrifices simply involved an increase of those prescribed for new moons (Nu 28 11-15), without changing their type. Perhaps Ps 81 was esp. written for this feast (cf ver 3).

Mentions of a special observance of the 1st of Tishri are found also in Ezk 45 20 (reading, as is necessary, "first day of seventh

**4. Origin** month" here for "seventh day") and Neh 8 1-12. In the former passage, the day is kept by offering a bullock as a sin offering and sprinkling its blood in a way that recalls the ritual of the Day of Atonement. In Neh an assembly of the people was held to hear Ezra read the Law. The day was kept as a festival on which mourning was forbidden (ver 9). Apart from these references there is no mention of the feast elsewhere in the OT, and, indeed, there is some reason to think that at one time the 10th, and not the 1st, of Tishri was regarded as the beginning of the year. For Ezk (40 1) specifically calls this day *rō'sh ha-shānāh*, and Lev 25 9 specifies it as the opening of the Jubilee year (contrast the Mish passage, above). Consequently scholars generally are inclined to assign Lev 23 23-25 and Nu 29 1-6 to the latest part of the Pent (P<sup>9</sup>). This need not mean that the observance of the 1st (or 10th) of Tishri was late, but only that the final adoption of the day into Israel's official calendar, with a fixed ritual for all Israelites, was delayed. If the original New Year's Day fell on the 10th of Tishri, its displacement ten days earlier was certainly due to the adoption of the 10th for the Day of Atonement. An explanation of the date of the latter feast would be gained by this supposition.

The instrument to be used in the trumpeting is not specified in the Bible, but Jewish tradition decided in favor of the horn and not the

**5. Later History** metal trumpet, permitting for synagogue use any kind of horn except a cow's, but for temple use only a straight (antelope's) horn and never a crooked

(ram's) horn (*Rō'sh ha-shānāh*, iii. 2-4). According to iv. 1, when the new year began on a Sabbath the horns were blown only in the temple, but after its destruction they were blown in every synagogue. Every Israelite was obliged to come within hearing distance of the sound (iii.7). In the synagogue

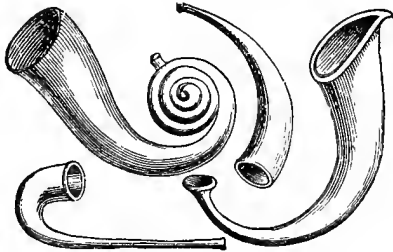

Ancient Horns and Curved Trumpets.

liturgy of iv.5-9 (which forms the basis of the modern Jewish practice), four sets of "benedictions" were read, and after each of the last three sets the horn blown nine times. Modern Judaism sees in the signals a call to self-examination and repentance, in view of the approaching Day of Atonement. See TRUMPET, III, 2, (8). BURTON SCOTT EASTON

**TRUST, BREACH OF:** The clearest reference to the crime designated by this modern expression is found in Lev 6 2-7, where the transgression is defined and the penalty set forth. Breach of covenant or contract and the removal of landmarks (Dt 19 14; 27 17; Prov 22 28; 23 10) may be included.

**TRUTH**, trōōth (אֱמֻנָה, 'emeth, אֱמֻנָה, 'emūnāh, primary idea of "firmness," "stability" [of Ex 17 12], hence "constancy," "faithfulness," etc; LXX Apoc and NT, ἀλήθεια, *alētheia* [Rom 3 7], πίστις, *pistis* [Rom 3 3]; in adjectival and adverbial sense, "in truth," "of a truth," "faithful," etc; ἀληθώς, *alēthōs* [Lk 21 3; Jn 6 14; 7 40; 1 Thess 2 13], ἀληθινός, *alēthinós* [Jn 17 3], ὄντως, *ontōs* [1 Cor 14 25], πιστός, *pistós* [1 Tim 3 1], in AV; RV, ARV, as generally, "faithful"; AS *trēow*, *tryw* with Teutonic stem *traw*, "to believe," "to keep faith"):

- I. TERMS
- II. GENERAL VIEW
  - 1. Aspects of Truth
    - (1) Ontological
    - (2) Logical
    - (3) Moral
    - (4) Religious
  - 2. Standards of Truth
  - 3. Special Features in Biblical Writings
- III. ANALYTICAL SUMMARY
  - 1. Truth in God
  - 2. Truth in Man
  - 3. Truth in Religion

**I. Terms.**—The Eng. word has developed and maintained the broadest, most general and varied usage, going beyond both Heb and Gr, which were already extended in connotation. It is possible to analyze and classify the special applications of the term almost indefinitely, using other terms to indicate specific meanings in special connections, e.g. loyalty (Jgs 9 15), honesty (Ex 18 21), fidelity (Dt 32 4), justice (Rom 2 2), uprightness (Isa 38 3), faith (26 2), righteousness (Ps 85 10), reality (Jn 17 19), veracity (Gen 42 16). It is unfortunate that translators have generally adhered to single terms to represent the original words. On the other hand, they have sometimes introduced words not represented in the original, and thus unduly limited the meaning. An example is Eph 4 15, where the original meaning "being true," i.e. in all respects, is narrowed to "speaking the truth."

**II. General View.**—No term is more familiar and none more difficult of definition.

With applications in every phase of life and thought the word has varying general senses which may be classified as:

(1) *Ontological truth*, i.e. accurate and adequate idea of existence as ultimate reality. In this sense it is a term of metaphysics, and will be differently defined according to the type of philosophical theory accepted. This aspect of truth is never primary in Scripture unless in the question of Pilate (Jn 18 38). He had so far missed the profound ethical sense in which Jesus used the word that Jesus did not at all answer him, nor, indeed, does Pilate seem to have expected any reply to what was probably only the contemptuous thrust of a skeptical attitude. In Prov where, if at all, we might look for the abstract idea, we find rather the practical apprehension of the true meaning and method of life (23 23). Ontological reality and possible ideas of reality apprehending it are obviously presupposed in all Scripture. There is objective reality on which subjective ideas depend for their validity; and all knowing is knowledge of reality. There is also in the whole of Scripture a subjective idea, the product of revelation or inspiration in some form of working, that constitutes an ideal to be realized objectively. The Kingdom of God, for example, is the formative idea of Scripture teaching. In a definite sense the kingdom exists and still it is to be created. It must be kept in mind, however, that only vaguely and indirectly does truth have abstract, metaphysical meaning to the Bib. writers. For John it approaches this, but the primary interest is always concrete.

**1. Aspects of Truth**

(2) *Logical truth* is expressive of the relation between the knower and that which is known, and depends upon the arrangement of ideas with reference to a central or composite idea. Truth in this sense involves the correspondence of concepts with facts. While this meaning of truth is involved in Scripture, it is not the primary meaning anywhere, save in a practical religious application, as in Eph 4 21; 1 Jn 2 4.21.

(3) *Moral truth* is correspondence of expression with inner conception. Taken in its full meaning of correspondence of idea with fact, of expression with thought and with intention, of concrete reality with ideal type, this is the characteristic sense of the word in the Scriptures. Here the aim of religion is to relate man to God in accordance with truth. In apprehension man is to know God and His order as they are in fact and in idea. In achievement man is to make true in his own experience the idea of God that is given to him. Truth is thus partly to be apprehended and partly to be produced. The emphatically characteristic teaching of Christianity is that the will to produce truth, to do the will of God, is the requisite attitude for apprehending the truth. This teaching of Jesus in Jn 7 17 is in accord with the entire teaching of the Bible. Eph 1 18 suggests the importance of right attitude for learning, while 4 18 shows the effect of a wrong attitude in ignorance of vital truth.

(4) *Religious truth* is a term frequently met in modern literature, but it has no sound basis in reason and it has none at all in the Bible. All truth is ultimately religious and only in a superficial way can religious truth be spoken of as an independent conception. Least of all can religious truth and scientific truth be at variance.

Philosophy has continuously tried to find tests for truth, and so has wrought out theories of knowledge—epistemologies. Not to go back

**2. Standards of Truth**

into the Gr philosophy, we have in modern times such theories as (1) the Kantian, (2) the scholastic, (3) the Hegelian, (4) the pragmatic, (5) that of the "new realism"; and these include only such as may be defined with some clearness, for the tendencies of current thought have been toward confusion concerning all standards of truth and reality, and so toward widespread agnosticism and skepticism. This temper has, naturally, reacted on thinking in practical ethics and upon the sanctions of religion. There is thus in religion and morals a tendency to obscure the distinction between what is and what ought to be. See AUTHORITY; ETHICS; PHILOSOPHY; RIGHT; SIN.

In the Bible the known will of God is final for man as a standard of truth, not as arbitrary, but as expressive of God's nature. God's nature is all-comprehensive of fact and goodness, and so is, all and in all, the source, support and objective of all concrete being. The will of God thus reveals, persuades to and achieves the ideals and ends of complete existence. The term "truth" is sometimes, therefore, nearly equivalent to the revealed will of God.

(1) The OT uses the term primarily of God and

applies the principle to man. The practical objective is ever prominent.

(2) The Synoptic Gospels and Acts use the term chiefly in popular idiomatic phrases "of a truth," "in truth," "surely" (cf Lk 22 59; Acts 4 27). In Mt 22 16 there is a more serious and comprehensive application, but it is in the flattering words of Pharisaic hypocrisy (cf Mk 12 14; Lk 20 21). To be sure, we are to understand that even in the phrases of common speech Jesus employed the term in all seriousness (Lk 4 25; 9 27).

(3) In Paul the sense of Divine faithfulness, as in the OT, is occasionally met (Rom 3 3.7; 15 8). Again the term emphasizes sincerity (1 Cor 5 8; 2 Cor 7 14). Generally it has direct or clearly implied reference to God's revelation in Jesus Christ with a view to redeeming men. In a general way the term is thus equivalent to the gospel, but there is never identification of the two terms (see Rom 2 8; Eph 1 13; 1 Tim 3 15). In Gal 2 5; 5 7, "the truth of the gospel" is its content in the purpose of God, in contrast with misconceptions of it: the true gospel as against false representations of the gospel.

(4) In the Johannine writings we find occasionally the emphatic phrase of genuineness (1 Jn 3 18; 2 Jn ver 1; 3 Jn ver 1) and emphatic reality (Jn 8 46; 16 7). In Rev we have "true" in the sense of trustworthy, because ultimately real or in accord with ultimate reality (3 7.14; 6 10; 15 3; 19 9.11, etc). Generally, as in the Gospel, we approach more nearly than elsewhere in Scripture a metaphysical use, yet always with the practical religious end dominant. Truth is reality in relation to the vital interests of the soul. It is primarily something to be realized and done, rather than something to be learned or known. In the largest aspect it is God's nature finding expression in His creation, in revelation, in Jesus Christ in whom "grace and truth came" (Jn 1 17), and finally in man apprehending, accepting and practically realizing the essential values of life, which are the will of God (Jn 1 14; 8 32; 17 19; 18 37 f; 1 Jn 2 21; 3 19). Truth is personalized in Jesus Christ. He truly expresses God, presents the true ideal of man, in Himself summarizes the harmony of existence and becomes the agent for unifying the disordered world. Hence He is the Truth (Jn 14 6), the true expression ("Logos," Jn 1 1) of God. See the same idea without the terminology in Paul (Col 1 14 ff; 2 9). Similarly, the Holy Spirit is the Spirit of truth because His function is to guide into all truth (Jn 16 13; 1 Jn 2 27; 5 7).

(5) It is understood by many that in Jas, Pet, He, and possibly the Pastoral Epp., the term connotes "the body of Christian teaching" (cf Jas 1 18; 3 14; 1 Pet 1 22; 2 Pet 2 2; He 10 26; 1 Tim 3 15). The use of the article here cannot be conclusive, and instead of "the body of Christian teaching," it seems more correct to understand the reality of life values as represented in the gospel plan of salvation and of living. In a general way this would include "the body of Christian teaching," but the reference would be less concrete. Jas is too early a writing to employ the term in this so specific a sense.

**III. Analytical Summary.**—(1) Truth is presented in Scripture as a chief element in the nature of God (Ps 31 5; Isa 65 16). (2)

**1. Truth in God** But this quality is never given as an abstract teaching, but only as qualifying God in His relations and activities.

So it is a guaranty of constancy (Dt 32 4; Ps 100 5; 146 6; Jas 1 17); esp. a ground of confidence in His promises (Ex 34 6; Ps 91 4; 146 6); of

right dealing with men without reference to any explicit pledges (Ps 85 11; 89 14); a basis of security in the correctness of His teachings (Neh 9 13; Ps 119 142; Isa 25 1); of assurance within His covenant relations (Ps 89 5; Isa 55 3).

(3) God's truth is esp. noteworthy as a guaranty of merciful consideration of men. This is an important element in the theology of the OT, as it is a point guarded also in the NT (Ps 25 10; 31 5; 61 7; 85 10; 98 3; Jn 3 16; Rom 3 23-26).

(4) Equally is the truth of God an assurance to men of righteous judgment in condemnation of sin and sinners (1 S 15 29; Ps 96 13; Rom 2 2.8). In general the truth of God stands for the consistency of His nature and guarantees His full response in all the relations of a universe of which He is the maker, preserver and end.

As related to God in origin and obligation, man is bound morally to see and respond to all the demands of his relations to God and to the order in which he lives under God.

**2. Truth in Man** (1) Truthfulness in speech, and also in the complete response of his nature

to the demand upon it, is urged as a quality to be found in man and is commended where found, as its lack is condemned. It is essential to true manhood. Here, as in the case of truth in God, truth is regarded as revealed in social relations and responsibilities. Truth is not merely in utterance, nor is it only response to a specific command or word, but lies in the response of the will and life to the essential obligations of one's being (Ps 15 2; 119 30; Prov 12 19; 23 23; Isa 59 4.14.15; Jer 7 28; 9 3; Hos 4 1; Rom 1 18.25; Eph 4 15; 2 Thess 2 10.12).

(2) Truth in man is in response to truth in God, and is to be acquired on the basis of a gift from God. This gift comes by way of teaching and also by way of the working of the Divine Spirit in the life of man. Highest truth in correspondence to ideal is possible only by the working of "the God of truth," in the spirit of the man. Man's freedom to realize his being is dependent upon his receptive attitude toward the Son of God. Hence salvation in its fullest idea is stated in terms of truth (Jn 11 3 ff; Phil 3 10 ff). See in general, Ps 51 6; Isa 25 1; Jn 3 21; 8 32; 16 13; 17 19; 18 37; Eph 4 21. 24; 5 9; He 10 26; 1 Jn 2 27.

The modern study of religion on an evolutionary hypothesis and the comparative study of religions have contributed to an extensive

**3. Truth in Religion** questioning whether there is any absolute truth in religion, or at least any standards by which truth in religion

may be known. Isa 43 and 44 and Paul in Acts 17 and Gal 3 accord with modern findings that there is an element of truth in religions generally, and that God's faithfulness pledges Him to bring the light of fuller truth to all men. This He does through the religion and the testimony of them to whom He has already come with this fuller light. This light is contained in the revealed word of the OT prophets and of the NT witnesses to Jesus. In a definite way the Scriptures preserve these standards of religious truth. But always the attitude of the individual, as also of the group, determines the measure of apprehension of the truth and the certainty with which it is held. It is always important to keep in mind that truth in religion is not primarily an intellectualistic affair, to be cognized, but is essentially a voluntaristic experience and a duty to be done for the glory of God in the realization of the complete truth of God. Jesus Christ as the truth of God becomes the standard and test for truth in the religion of men. And this not in any objective and formal way of a series of propositions, to be accepted and contended for,

but in the subjective way of experience, in a series of ideals to be realized and propagated. If any man wishes to do God's will, he shall be able to decide the truth of religious teaching, and the Son who is true will give the freedom of truth (Jn 7 17; 8 32).

WILLIAM OWEN CARVER

**TRYPHAENA**, trī-fē'na (Τρύφαινα, *Trúphaina*; AV *Tryphena*): Tryphaena is coupled with "Tryphosa"—among those members of the Christian community at Rome to whom Paul sends greetings (Rom 16 12). He describes them as those "who labor in the Lord." "The names, which might be rendered 'Dainty' and 'Disdain' (see Jas 5 5; Isa 66 11), are characteristically pagan, and unlike the description" (Denney). They were probably sisters or near relatives, for "it was usual to designate members of the same family by derivatives of the same root" (Lightfoot, *Phil*, 175). Both names are found in inscriptions connected with the imperial household, "Tryphosa" occurring more frequently than "Tryphaena." S. F. HUNTER

**TRYPHON**, trī'fon (Τρύφων, *Trúphōn*): The surname of Diodotus, a usurper of the Syrian throne. He was a native of Apamea, and had been in the service of Alexander Balas. On the death of Balas (145 BC), Tryphon, taking advantage of the murmurs of discontent among the troops of Demetrius II (Nicator), set up the younger son of Balas, Antiochus VI, as claimant to the throne against Demetrius (1 Macc 11 39). The Jews under Jonathan came to the assistance of Demetrius in his difficulties against his revolting subjects. But Demetrius, when confirmed on his throne, soon made it apparent that he did not intend to fulfil his promises to his Jewish allies (11 53). Consequently Jonathan and Simon joined Tryphon and Antiochus VI, securing many advantages for their country (11 54 ff). Jonathan inflicted a severe defeat on the forces of Demetrius. The successes of the Jewish leaders awakened the jealousy and suspicion of Tryphon, who determined to thwart the further plans of Jonathan and to remove him as an obstacle in the way of his securing the crown for himself. By an act of shrewd treachery, Tryphon captured Jonathan at Ptolemais and butchered all his followers (12 48). Simon, brother of Jonathan, now undertook the conduct of affairs and thwarted Tryphon in his attempts upon Jerus, whereupon the latter murdered Jonathan at Bascama (13 1 ff) in 143 BC. Tryphon next murdered the young Antiochus VI (13 31) and claimed the throne of Syria for himself (143 BC) (but see the chronology as given in Schürer, *HJP*, 4th ed, I, 172). Simon now went over to the side of Demetrius on condition that Judaea should be free from tribute to Syria—a privilege that was rather in the power of Tryphon than of Demetrius to give, and so "in the 170th year [143 BC] was the yoke of the heathen taken away from Israel" (13 41). In 138 BC Demetrius was captured by Mithridates I (Arsaces), king of Parthia (14 2). His brother, Antiochus VII (Sidetes), continued the struggle against Tryphon, first with the aid of Simon, but later repudiating it. Tryphon was obliged to flee before Sidetes to Dor (15 11), where Antiochus refused the assistance of Simon (15 26). He next escaped to Ptolemais, then to Orthosia, and finally to his native Apamea, where he was driven to suicide (Jos, *Ant*, XIII, vii, 2; Strabo, 668; Appian, *Syr*, 68). (The best account is given in Schürer, 4th ed, I, 172 ff; cf also *Speaker's Comm.* in loc.) See ANTIOCHUS; DEMETRIUS. S. ANGUS

**TRYPHOSA**, trī-fō'sa (Τρυφήσα, *Truphōsa*): Greetings are sent by Paul to "Tryphaena and Try-

phosa, who labor in the Lord" (Rom 16 12). See TRYPHAENA.

**TSADHE**, tsä-thā'. See ÇADHE.

**TUBAL**, tū'bal (תּוּבַל, *tūbhal*; LXX Θόβελ, *Thóbel*, A in Ezk 39 1, Θόβερ, *Thóber*): As the text stands, Tubal and Meshech are always coupled, except in Isa 66 19 (MT) and Ps 120 5. In the former passage Tubal is yoked with Javan; in the latter Meshech occurs in ver 5 and Kedar in ver 6. In Gen 10 2||, they are sons of Japheth. In Ezk (27 13) the two are mentioned as exporters of slaves and copper, as a warlike people of antiquity (32 26), in the army of Gog (38 2 ff; 39 1). Jos identifies them with the Iberians and Cappadocians respectively; but they are most probably the *Tibarēnoi*, *Tibarēnoi*, and *Móschoi*, first mentioned in Herod. iii.94 as belonging to the 19th satrapy of Darius, and again (vii.78) as furnishing a contingent to the host of Xerxes. Equally obvious is their identity with the Tabali and Muški of the Assyrian monuments, where the latter is mentioned as early as Tiglath-pileser I, and the former under Shalmaneser II; both are described as powerful military states. They appear together in Sargon's inscriptions; and during this entire period their territory must have extended much farther S. and W. than in Gr-Rom times. They are held (Winckler and Jeremias) to have been remnants of the old Hittite population which were gradually driven (probably by the Cimmerian invasion) to the mountainous district S.E. of the Black Sea.

HORACE J. WOLF

**TUBAL-CAIN**, tū'bal-kān (תּוּבַל קַיִן, *tūbhal kayin*): One of the sons of Lamech (Gen 4 22). He is a brother of Jabal and Jubal, who appear to have been the founders of several industries and arts. The text (לָטַשׁ כְּלִי־חַרֶשׁ נְחֹשֶׁת וּבְרֹזֶל, *lōtēsh kol hōrēsh n'hōsheth ū-bharzel*) has been the cause of endless dispute. Holzinger and Gunkel hold that לָטַשׁ was a marginal gloss to חָרַשׁ, and that, as in vs 20 and 21, there stood before כְּלִי originally אָבִי הַיָּהוּבָה, *hū hāyāh 'ābhī*. This would make Tubal-cain the founder of the metal industry, and place him in a class similar to that of his brothers. The LXX, however, has no equivalent of קַיִן. This omission leads Dillmann, Wellhausen, and others to the position that "Tubal" originally stood alone, and קַיִן, being a later addition, was tr<sup>d</sup> "smith." Many commentators identify Tubal with the Assyrian Tubal, a people living S.W. of the Black Sea; in later times they were called "Tibareni" (Ezk 27 13). Tubal may be the eponymous ancestor of these people, whose principal industry seems to have been the manufacture of vessels of bronze and iron.

HORACE J. WOLF

**TUBIAS**, tū'bi-as, tū'bi-as (ἐν τοῖς Τοβίου, *en tois Tobioi*; AV "in the places of Tobie," RV "in the land of Tubias"): A place in Gilead where 1,000 men of the Jews were slaughtered by the Gentiles, their wives and children being carried away captive (1 Macc 5 13). It is identified with the land of Tob (q.v.).

**TUBIENI**, tū-bi-ē'nī (πρὸς τοὺς λεγομένους Τουβιηνούς Ἰουδαίους, *prōs tois legomēnous Toubiēnous Ioudaious*, "unto the Jews that are called Tubieni"): Men of Tob (q.v.) who had occupied the town of Chirax (2 Macc 12 17).

**TUMOR**, tū'mēr, tū'mor (עֶמֶר, *'ēphel*): RV substitutes this word for "emerods" in 1 S 5 12; 6 4; Dt 28 27 m. See EMERODS.

**TURBAN**, tûr'ban (Lev 16 4 m). See DRESS, V.

**TURPENTINE**, tûr'pen-tîn, **TREE**. See TERE-BINTH.

**TURTLE-DOVE**, tûr't'l-div. See DOVE.

**TUTOR**, tû'têr: In modern Eng. an "instructor," more particularly a private instructor, but the word properly means a "guardian." Hence its use in Gal 4 2 AV for ἐπιτροπος, *epítropos*, here "guardian" (so RV), and 1 Cor 4 15; Gal 3 24.25 RV for παιδαγωγός, *paidagōgós*. See SCHOOLMASTER.

**TWELVE**, twelv (שְׁנַיִם עָשָׂר, *sh'nēm 'āsār*; δώδεκα, *dōdeka*). See APOSTLE; NUMBER.

**TWELVE APOSTLES, GOSPELS OF THE**. See APOCRYPHAL GOSPELS.

**TWELVE PATRIARCHS, TESTAMENTS OF THE**. See APOCALYPTIC LITERATURE, IV, 1.

**TWELVE STARS**. See ASTRONOMY, II, 12.

**TWENTY**, twen'ti. See NUMBER.

**TWILIGHT**, twi'lit (נֶשֶׁפֶת, *nesheph*): The twilight of Pal is of short duration, owing to the low latitude, there being scarcely more than an hour between sunset and complete darkness. It is a distinct boundary between daytime and the darkness. The people of Pal still give the time of an event as so many hours before or after sunrise or sunset: "David smote them from the twilight even unto the evening of the next day" (1 S 30 17), and "They rose up in the twilight, to go" (2 K 7 5). The word is evidently used in the sense of darkness in "the stars of twilight" (Job 3 9) and "The adulterer waiteth for the twilight" (Job 24 15). AV has "twilight" in Ezk 12 6 ff, but RV has "dark."

ALFRED H. JOY

**TWIN BROTHERS** (Acts 28 11). See DIOSCURL.

**TWINE**, twîn (רִשְׁוֹן, *shāzar*, "to be twined"): The word is used in Ex 26 1 ff; 36 8 ff, etc, of the "fine twined linen" used for the curtains and hangings of the tabernacle, and for parts of the priests' dress. It denotes linen the finely spun threads of which consisted of two or more smaller threads twined together. See LINEN; TABERNACLE.

**TWO**, tōō. See NUMBER.

**TYCHICUS**, tik'i-kus (Τύχικος, *Tychikos*, lit. "chance"): Mentioned 5 t in the NT (Acts 20 4; Eph 6 21; Col 4 7; 2 Tim 4 12; Tit 3 12); an Asiatic Christian, a friend and companion of the apostle Paul.

(1) In the first of these passages his name occurs as one of a company of the friends of Paul. The apostle, at the close of his 3d missionary journey, was returning from Greece through Macedonia into Asia, with a view to go to Jerus. This journey proved to be the last which he made, before his apprehension and imprisonment. It was felt, both by himself and by his friends, that this journey was a specially important one. He was on his way to Jerus, "bound in the spirit" (Acts 20 22). But another cause which gave it particular importance was that he and his friends were carrying the money which had been collected for several years previous in the churches of the Gentiles, for the help of the poor members of the church in Jerus (Acts 24 17). No fewer than eight of his intimate friends ac-

companied him into Asia, and one of these was T. Luke uses the word "Asian" (EV "of Asia," Acts 20 4) to describe T. He was with Paul at Troas, and evidently journeyed with him, as one of "Paul's company" (Acts 21 8 AV), all the way to Jerus.

(2) The 2d and 3d passages in which the name of Tychicus occurs (see above) give the information that he was with Paul in Rome during his first imprisonment. In Col Paul writes, "All my affairs shall Tychicus make known unto you, the beloved brother and faithful minister and fellow-servant in the Lord: whom I have sent unto you for this very purpose, that ye may know our state, and that he may comfort your hearts" (4 7.8). In almost identical words he writes in Eph, "But that ye also may know my affairs, how I do, Tychicus, the beloved brother and faithful minister in the Lord, shall make known to you all things: whom I have sent unto you for this very purpose, that ye may know our state, and that he may comfort your hearts" (6 21.22).

Paul had intrusted T. with a very important mission. He was to deliver the Ep. to the Eph, that is, "the circular letter" (see LAODICEANS, EPISTLE TO THE) to the churches in proconsular Asia, to which it was sent, giving a copy of it to the church in Laodicea. He was then to proceed to Colossae, with the Ep. to the church there. In Colossae T. would plead the cause of Onesimus, who accompanied him from Rome. "Under his shelter Onesimus would be safer than if he encountered Philemon alone" (Lightfoot, *Comm. on Col.* 314). In Laodicea and Colossae T. would not only deliver the Epp. from Paul, but he would also, as the apostle had written to the churches in those places, communicate to them all information about his "state," that is, how things were going with him in regard to his appeal to the emperor, and his hope of being soon set at liberty. T. would make known to them all things.

(3) The passages in the Epp. to Titus and to Timothy show that T. was again with Paul, after the appeal to the emperor had resulted in the apostle regaining his freedom. The passage in Tit evidently refers to the interval between Paul's first and second Rom imprisonments, and while he was again engaged in missionary journeys. The apostle writes to Titus, who was in Crete in charge of the churches there, that he intended to send either Artemas or T. to him, so as to take the oversight of the work of the gospel in that island, that Titus might be free to come to be with the apostle at Nicopolis.

(4) The last passage where T. is mentioned occurs in 2 Tim, which was written in Rome not long before Paul's execution. To the very end Paul was busy as ever in the work of the gospel; and though it would have been a comfort to him to have his friends beside him, yet the interests of the kingdom of Christ are uppermost in his thoughts, and he sends these friends to help the progress of the work. To the last, T. was serviceable as ever: "Tychicus I sent to Ephesus" (4 12). As Timothy was in charge of the church in Ephesus (1 Tim 1 3), the coming of T. would set him free, so as to enable him to set off at once to rejoin Paul at Rome, as the apostle desired him (2 Tim 4 9.21).

It should also be noted that at Ephesus T. would be able to visit his old friend Trophimus, who was, at that very time, only a few miles away—at Miletus, sick (2 Tim 4 20).

It is possible that T. is the brother referred to in 2 Cor 8 22.23 as one "whom we have many times proved earnest in many things . . . [one of] the messengers of the churches . . . the glory of Christ."

(5) The character and career of T. are such as show him altogether affectionate, faithful and worthy of the confidence reposed in him by Paul, who, as already seen, sent him again and again on important work, which could be performed only by a man of ability and of high Christian worth and experience. Thus all that is known regarding T. fully bears out the description of his character given



by the apostle himself, that he was a beloved brother, a faithful minister and fellow-servant in the Lord.

JOHN RUTHERFURD

#### TYPE, tip:

1. Definition of Type
2. Distinctive Features
3. Classification of Types
4. How Much of the OT Is Typical?

#### LITERATURE

The Bible furnishes abundant evidence of the presence of types and of typical instruction in the Sacred Word. The NT attests this fact. It takes up a large number of persons and things and events of former dispensations, and it treats them as adumbrations and prophecies of the future. A generation ago a widespread interest in the study of typology prevailed; latterly the interest has largely subsided, chiefly because of the vagaries and extravagances which attended its treatment on the part of not a few writers. Pressing the typical teaching of Scripture so far as to imperil the historical validity of God's word is both dangerous and certain to be followed by reaction and neglect of the subject.

The word "type" is derived from a Gr term *τύπος*, *túpos*, which occurs 16 t in the NT. It is variously

tr<sup>d</sup> in AV, e.g. twice "print" (Jn 20 25); twice "figure" (Acts 7 43; Rom 2 14); twice "pattern" (Tit 2 7; He 8 5); once "fashion" (Acts 7 44); once "manner" (Acts 23 25); once "form" (Rom 6 17); and 7 t "example" (1 Cor 10 6.11; Phil 3 17; 1 Thess 1 7; 2 Thess 3 9; 1 Tim 4 12; 1 Pet 5 3). It is clear from these texts that the NT writers use the word "type" with some degree of latitude; yet one general idea is common to all, namely, "likeness." A person, event or thing is so fashioned or appointed as to resemble another; the one is made to answer to the other in some essential feature; in some particulars the one matches the other. The two are called type and antitype; and the link which binds them together is the correspondence, the similarity, of the one with the other.

Three other words in the NT express the same general idea. One is "shadow" (*σκιά*, *skiá*, He 10 1), "For the law having a shadow of the good things to come"—as if the substance or reality that was still future cast its shadow backward into the old economy. "Shadow" implies dimness and transitoriness; but it also implies a measure of resemblance between the one and the other.

The 2d term is "parable" (*παραβολή*, *parabolé*, He 9 9); the tabernacle with its services was an acted parable for the time then present, adumbrating thus the blessed reality which was to come.

The 3d term is "copy," or "pattern" (*ὑπόδειγμα*, *hypódeigma*), a word that denotes a sketch or draft of something future, invisible (He 9 23); the tabernacle and its furniture and services were copies, outlines of heavenly things.

Types are pictures, object-lessons, by which God taught His people concerning His grace and saving power. The Mosaic system was a sort of kindergarten in which God's people were trained in Divine things, by which also they were led to look for better things to come. An old writer thus expresses it: "God in the types of the last dispensation was teaching His children their letters. In this dispensation He is teaching them to put the letters together, and they find that the letters, arrange them as they will, spell Christ, and nothing but Christ."

In creation the Lord uses one thing for many purposes. One simple instrument meets many ends. For how many ends does water serve! And the atmosphere: it supplies the lungs, conveys sound, diffuses odors, drives ships, supports fire, gives rain, fulfils besides one knows not how many other purposes. And God's word is like His work, is His work, and, like creation, is inexhaustible. Whatever God touches, be it a mighty sun or an insect's wing, a vast prophecy or a little type, He perfects for the place and the purpose He has in mind.

What are the distinctive features of a type? A type, to be such in reality, must possess three well-defined qualities. (1) It must be a true picture of the person or the thing it represents or prefigures. A type is a draft or sketch of some well-defined feature of redemption, and

therefore it must in some distinct way resemble its antitype, e.g. Aaron as high priest is a rough figure of Christ the Great High Priest, and the Day of Atonement in Israel (Lev 16) must be a true picture of the atoning work of Christ. (2) The type must be of Divine appointment. In its institution it is designed to bear a likeness to the antitype. Both type and antitype are preordained as constituent parts of the scheme of redemption. As centuries sometimes lie between the type and its accomplishment in the antitype, of course infinite wisdom alone can ordain the one to be the picture of the other. Only God can make types. (3) A type always prefigures something future. A Scriptural type and predictive prophecy are in substance the same, differing only in form. This fact distinguishes between a symbol and a type. A symbol may represent a thing of the present or of the past as well as of the future, e.g. the symbols in the Lord's Supper. A type always looks to the future; an element of prediction must necessarily be in it.

Another thing in the study of types should be borne in mind, namely, that a thing in itself evil

cannot be the type of what is good and pure. It is somewhat difficult to give a satisfactory classification of Bib. Types, but broadly they may be distributed under three heads: (1) Personal types, by which are meant those personages of Scripture whose lives and experiences illustrate some principle or truth of redemption. Such are Adam, who is expressly described as the "figure of him that was to come" (Rom 5 14), Melchizedek, Abraham, Aaron, Joseph, Jonah, etc. (2) Historical types, in which are included the great historical events that under Providence became striking foreshadowings of good things to come, e.g. the Deliverance from the Bondage of Egypt; the Wilderness Journey; the Conquest of Canaan; the Call of Abraham; Deliverances by the Judges, etc. (3) Ritual types, such as the Altar, the Offerings, the Priesthood, the Tabernacle and its furniture. There are typical persons, places, times, things, actions, in the OT, and a reverent study of them leads into a thorough acquaintance with the fulness and the blessedness of the word of God.

How much of the OT is to be regarded as typical is a question not easily answered. Two extremes,

however, should be avoided. First, the extravagance of some of the early Fathers, as Origen, Ambrose, Jerome (revived in our time by Andrew Jukes and his imitators). They sought for types, and of course found them, in every incident and event, however trivial, recorded in Scripture. Even the most simple and commonplace circumstance was thought to conceal within itself the most recondite truth. Mystery and mysticism were seen everywhere, in the cords and pins of the tabernacle, in the yield of herds, in the death of one, in the marriage of another, even in the number of fish caught by the disciples on the night the risen Saviour appeared to them—how much some have tried to make of that number, 153! The very serious objection to this method is, that it wrests Scripture out of the sphere of the natural and the historical and locates it in that of the arbitrary and the fanciful; it tends to destroy the validity and trustworthiness of the record.

4. How Much of the OT Is Typical?

Second, the undue contraction of the typical element. Professor Moses Stuart expresses this view as follows: "Just so much of the OT is to be accounted typical as the NT affirms to be so, and no more." This opinion assumes that the NT writers have exhausted the types of the OT, while the fact is that those found in the later Scripture are but samples taken from the storehouse where many more are found. If they are not, then nothing is more arbitrary than the NT use of types, for there is nothing to distinguish them from a multitude of others of the same class. Further, the view assumes that Divine authority alone can determine the reality and import of types—a view that applies with equal force against prophecy. This rule may be safely followed: wherever the three characteristics of types are found which have been already mentioned, there is the type.

identify him with a certain Tyrannus, a sophist, mentioned by Suidas. Paul would thus appear to be one of the traveling rhetors of the time, who had hired such a hall to proclaim his own peculiar philosophy (Ramsay, *Paul the Traveller*, 246, 271).

(2) Meyer thinks that as the apostle had not passed wholly to the Gentiles, and Jews still flocked to hear him, and also that as Tyrannus is not spoken of as a proselyte (*sebómenos tón Theón*), this *scholē* is the *bēth Midhrāsh* of a Jewish rabbi. "Paul with his Christians withdrew from the public synagogue to the private synagogue of Tyrannus, where he and his doctrine were more secure from public annoyance" (Meyer in loc.).

(3) Another view (Overbeck) is that the expression was the standing name of the place after the original owner. S. F. HUNTER



VIEW OF TYRE.

Weighty are the words of one equally eminent for his piety as for his learning: "That the OT is rich in types, or rather forms in its totality *one* type, of the NT, follows necessarily from the entirely unique position which belongs to Christ as the center of the history of the world and of revelation. As we constantly see the principle embodied in the vegetable and animal kingdoms, that the higher species are already typified in a lower stage of development, so do we find, in the domain of saving revelation, the highest not only prepared for, but also shadowed forth, by that which precedes in the lower spheres" (Van Oosterzee).

LITERATURE.—P. Fairbairn, *Typology of Scripture*, 2 vols; Angus, *The Bible Hand-Book*; Jukes, *Law of Offerings in Lev*; Mather, *Gospel of OT*, *Explanation of Types*; McEwen, *Grace and Truth: Types and Figures of the OT*; Soltau, *Tabernacle, Priesthood and Offerings*.

WILLIAM G. MOOREHEAD

**TYRANNUS**, tī-ran'us (Τύραννος, *Túrannos*): When the Jews of Ephesus opposed Paul's teaching in the synagogue, he withdrew, and, separating his followers, reasoned daily in the school of Tyrannus. "This continued for the space of two years" (Acts 19 9,10). D Syr (Western text) adds after Tyrannus (ver 9), "from the 5th hour unto the 10th." *Scholē* is the lecture-hall or teaching-room of a philosopher or orator, and such were to be found in every Gr city. Tyrannus may have been (1) a Gr rhetorician or (2) a Jewish rabbi.

(1) This is the common opinion, and many

**TYRE**, tīr (צֵר, צָר, *ṣār*, "rock"; Τύρος, *Túros*, "Tyrus"; modern *Sūr*): The most noted of the

Phoen cities, situated on the coast, 1. **Physical Features** lat. 33° 17', about 20 miles S. of Sidon and about 35 N. of Carmel. The date

of its foundation is uncertain, but it was later than that of Sidon. It is mentioned in the travels of the Egyp Mohar, dating probably from the 14th cent. BC, and in the Am Tab of about the same period. Herodotus describes the temple of Hercules at T. and says it was built 2,300 years before his time, which would carry back the beginning of the city to more than 2700 BC. It was a double city, one part on an island, a short distance from the shore, and the other on the mainland opposite. The island city had two harbors, connected by a canal, one looking N. and the other S. The island was rocky and the city was fortified on the land side by a wall 150 ft. high, the wall being of less elevation on the other sides. It was an exceedingly strong position, and is referred to in the Bible as the "strong" or "fortified" city (Josh 19 29). The space within the walls was crowded with buildings, and is said to have contained 40,000 inhabitants. The town on the mainland was situated in a plain extending from the *Ras el-'Abyad*,

on the S. to Sarepta on the N., a distance of about 20 miles. It was fertile and well watered, the river Leontes (Litany) passing through it to the sea, about 5 miles N. of Tyre, and the copious fountain of *Ras el-'Ain*, 3 miles to the S., furnishing an abundant supply both for the city and the gardens.

(1) T. was for centuries subordinate to Sidon, but when the Philis subdued the latter city, probably in the 12th cent. (see SIDON), Tyre received an accession of inhabitants from the fugitives which gave it the preëminence. From this time dates its great commercial and colonial activity. Its mariners pushed boldly out to the W. and founded colonies in Spain and North Africa, some of which, like Gades, Abdera and Carthage, became famous. They extended their commerce more widely than Sidon had ever done and ventured into the Atlantic and reached the coasts of Britain and West Africa. They reached out to the E. also, and had their ships in the Red Sea and the Indian Ocean, and their land routes threaded all Western Asia (see PHOENICIA). T., like all the Phoen cities, became subject to Egypt under Thothmes III in the first half of the 15th cent. BC, and remained so for some 300 years, but it enjoyed practical autonomy under native kings, being only subject to tribute and to furnishing contingents of ships when the Egyp kings made their expeditions to the N. In the Am Tab, dating from the first half of the 14th cent., we find a certain Abi-melek (or Abi-milki) writing from T. to the king of Egypt asking for aid against the Amorite leader, Aziru, and the king of Sidon, who had joined the rebels. The name is Phoen, and we know that it was the policy of the Egyp kings to leave the native dynasts on the throne.

(2) After the decline of Egypt, T. regained her independence and exercised the hegemony over most of the Phoen towns, at least as far N. as Gebal (Byblus), as appears in the control that Hiram had over the Lebanon forests in the time of David and Solomon. Hiram was evidently desirous of an alliance with Israel, since he sent messengers to David and furnished cedar and workmen to build him a house, apparently without solicitation. The friendly connection between the two kingdoms was advantageous to both, since David and Solomon needed the timber and the skilled artisans that Hiram could furnish, and Hiram needed the food products of the land of Israel (1 K 5). T. was at this time noted for the skill of its artificers, and its manufactured products were famous throughout the world (see PHOENICIA, 4). The purple dye and works in bronze were esp. famous, and Hiram, the Tyrian artisan, was engaged by Solomon to cast the bronzes required for the temple (1 K 7 13 ff). Hiram, the king, enlarged and beautified his capital. He united the two small islands on which the city was built by filling up the space between, where he made an open square and built a splendid temple to Melkarth and Astarte. He engaged in commercial enterprises with Solomon (1 K 9 26-28; 10 22), both in pursuance of the friendly alliance and also for the advantage of having the use of the port of Ezion-geber on the Red Sea. His brilliant reign lasted 43 years.

(3) The list of kings who succeeded him contains the names of Baal-azar, Abd-ashtoreth, murdered by his brothers, the eldest of whom succeeded him, followed by Astartus and Aserymus murdered by his brother, Pheles, who was overthrown by the high priest Eth-baal, showing how disturbed the period was. Eth-baal, or Ithobal, was the king who made an alliance with Ahab and gave him Jezebel, his daughter, in marriage, which proved most disastrous both to her and the country because of the introduction of the Baal-worship into Israel. Eth-baal was an energetic monarch, and is said to

have founded Botrys (*Batrûn*). He reigned 32 years, and was followed by Badezor and Mattan, who gave his daughter, Elissa (Dido), in marriage to her uncle Sicharbas and transferred the throne to them; but they were set aside by an uprising of the people, and Pygmalion, son of Mattan, was placed on the throne, and Sicharbas put to death. Elissa fled with a party of nobles, by sea, to Africa and founded the city of Carthage. This happened about the middle of the 9th cent. BC, Jos putting it at 860.

(4) In the first half of this century T. became subject to Assyria, and her hegemony in Phoenicia came to an end, but her prosperity was not seriously checked as we may infer from Isa 23 8, which was written a century or so later. Assyria was satisfied with the payment of tribute until the time of Tig-lath-pileser III (745-727), who laid a heavier hand upon her, and this led Elulæus, king of T., to form a confederacy of the Phoen cities against Assyria. Shalmaneser IV subdued all except T., which he distressed by cutting off her water-supply. But the people dug wells and obtained enough to subsist upon for five years, when Shalmaneser was killed and Elulæus recovered control of his territory. He was not molested by Sargon, but Sennacherib advanced against him with 200,000 men, and Elulæus fled to Cyprus. The citizens made a successful resistance and Sennacherib did not take T., but it submitted to Esar-haddon, and its king, Baal, obtained the special favor of the Assy king, who made him ruler of all the coast cities from Dor to Gebal, and the Lebanon was placed under his control (680-673 BC). It is rather surprising that Baal refused to assist him in his attack upon Egypt and that Esar-haddon did not punish him, probably because he was too much occupied with Egypt. Ashur-bani-pal, however, did compel him to submit and to give him his daughter, and those of his brothers, as secondary wives, but left him as king of T.

(5) On the decline of Assyria, T. regained its independence, and its greatness is indicated by the fact that it resisted Nehuchadnezzar 13 years (598-585); it is uncertain whether the island city was taken, but it evidently came to terms with the king of Babylon (cf Ezk 27 26; Jos, *Ant.*, X, xi, 1 and see *Expos* 7, 1899, pp. 378, 430, 475, 520). After this siege Sidon took the lead and T. was in a disturbed state; the monarchy was overthrown and suffetes, or judges, took its place for six years, when the old order was restored. The decline of Babylon enabled T. to regain her independence for a short period until its submission to the Persians about 525 BC, and thenceforth it was a vassal state during the continuance of the Pers empire.

(6) It was by no means hindered in its commercial prosperity, and its great strength is seen in the brave and energetic resistance it made to Alexander the Great. All Phoenicia submitted to him without resistance, and T. was willing to admit his suzerainty, but declined to receive him into the city. This so angered Alexander that he at once commenced a siege that proved the most difficult undertaking in all his wars. He had no fleet and was obliged to build a mole from the mainland to the island, but before he could finish it the Tyrians destroyed it and beat back their assailants with loss. Alexander had to do the work all over again, and as he was convinced that without a fleet he would not be able to take the city, he procured ships from the Phoen towns that had submitted, and with the aid of these was able to blockade the port and prevent the besieged from issuing forth to destroy the new mole. This was at length pushed up to the very wall of the city, which was finally breached, and the troops of Alexander forced their way in. But even then the defenders would not yield, and the king himself had to lead the assault upon them with his bodyguard and put them all to the sword. Those who died with arms in their hands were 8,000, and the survivors, women, children and slaves, to the number of 30,000, were sold in the open market. He placed over the ruined city, into which he introduced some colonists, a certain Abd-donim, and left it after having spent about seven months in subduing it.

(7) After the death of Alexander, T. passed into the hands of Ptolemy Lagi, and when Antigonus, in 314 BC, took Phoenicia from him, T. resisted, and he had to blockade it 15 months before it would yield, showing how quickly it had recovered from

its previous disaster. It became a part of the Seleucid kingdom when Antiochus III drove the Ptolemies from Syria (198 BC), and the Seleucid kings regarded it of importance and gave it the right of asylum, and it was allowed the status of a free city by the Romans, Antony recognizing the mag-

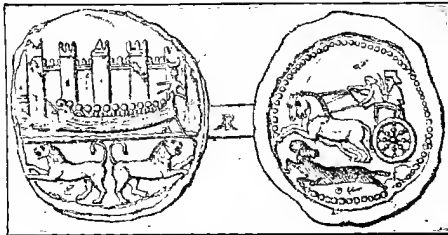

Coin of Tyre.

istrates and council of T. as allies. When the Parthians attacked and took Syria, in 40 BC, T. would not submit and was left untouched, being too strong for them. Augustus deprived it of its freedom, but it was given the status of a "metropolis" by Hadrian, and this title appears on its coins.

(8) T. is mentioned in the NT several times: Christ visited its territory (Mt 15 21; Mk 7 24), and people from there came to hear Him (Lk 6 17). Herod Agrippa I had trouble with T., and a deputation came to visit him at Caesarea (Acts 12 20). Paul visited T. on his journey from Asia to Jerus (Acts 21 3-7).

Christianity was accepted by the people of T., so that the 2d cent. AD saw a bishopric established there, and in the 4th a council was held there to consider charges against Athanasius, by the party of Arius; he was condemned, a decision which brought the Tyrian church into disrepute. T. was already obnoxious to Christians because the anti-Christian philosopher Porphyry was from there. Tyre continued a commercial center, and Jerome says that it was the noblest and most beautiful of the Phoen cities and an emporium of commerce for almost the whole world (*Comm. on Ezk*). It was of considerable importance in the Crusades and continued so until toward the end of the 13th cent., when its trade declined, and it has now dwindled to a town of some 5,000 inhabitants. For "literature" see PHENICIA.

H. PORTER

**TYRE, LADDER OF** (κλίμακος Τύρου, *klimakos Týrou*): Given in 1 Macc 11 59 as the northern limit of the territory placed under the authority of Simon Thassi the Maccabee by Antiochus VI (Theos), in the year 143 BC. The statement of Jos (*BJ*, II, x, 2) that it was 100 furlongs N. of Ptolemais, and a similar indication of position in the Jer Talm (*Ab Zar* 1 9) lead us to identify it with *Rās-en-Nakūrāh* and not with *Rās-el-'Abyad* (*Promontorium Album* of Pliny), as has been done. Here the rugged hills of Upper Galilee descend in bold precipices to the sea and leave no beach between. A natural barrier is thus formed which prevented the histories of Israel and Tyre from ever touching one another except in peaceful relations.

W. M. CHRISTIE

**TYROPÆON**, tī-rō-pē'on, **THE**. See JERUSALEM.

**TYRUS**, tī'rus. See TYRE.

**TZADDI**, tzā-dē'. See ÇADHE.

U

**UCAL**, ū'kal (אֲכָל, 'ukhāl [see below]): This name occurs along with that of Ithiel (Prov 30 1), both being taken by older interpreters as those of ancient sages. Some have suggested (see Toy, *Prov*, 519 f) that Ucal might be the "Calcol" of 1 K 4 31 (Heb 5 11). Ucal was also explained as "I can," i.e. "I can maintain my obedience to God," just as Ithiel was taken to be "signs of God." LXX, Aq, Theodotion do not take the words as proper names, and so *BDB* with others point this word as a vb., "[and] I am consumed" (אֲכָל, *wā'ekhel*, for אֲכָל, *w'ekhāl*). The last three words of the verse are then tr<sup>d</sup> "I have wearied myself, O God, I have wearied myself, O God, and am consumed." See ITHIEL. DAVID FRANCIS ROBERTS

**UEL**, ū'el (אֲוֵל, 'u'el, "will of God"): One of the sons of Bani who had taken foreign wives (Ezr 10 34). The name in 1 Esd 9 35 is "Juel" (B, 'Oυήλ, *Ouēl*, A, 'Iουήλ, *Iouēl*).

**UKNAZ**, uk'naz (אֲכָנָז, *uk'naz*, "and Kenaz," probably): Found in AVm of 1 Ch 4 15 for AV "even Kenaz," RV "and Kenaz," whereas LXX omits "and." It is probable that some name has dropped out after Elah. Curtis suggests reading "and these are the sons of Kenaz," i.e. those mentioned in vs 13 f. See KENAZ.

**ULAI**, ū'lī, ū'lā-i (אֲוּלַי, 'ubhal 'ulāy, "river Ulai"; Theod. Dnl 8 2, Οὐβάλ, *Oubāl*; LXX and Theod. in ver 16, Οὐλάτ, *Oulāt*;

**1. The Name and Its Forms** Lat *Eulaeus*): A river which, running through the province of Elam, flowed through Shushan or Susa. It was from "between" this river that Daniel (8 16) heard a voice, coming apparently

from the waters which flowed between its two banks.

Notwithstanding that the rivers of Elam have often changed their courses, there is but little doubt that the Ulai is the Kerkhah, which

**2. Present Names and Course** rising in the Pers plain near Nehāvend (there called the *Gamas-āb*), is even there a great river. Turned by the mountains, it runs N.W. as far as Bisūtūn, receiving all the waters of Southern Kurdistan, where, as the *Sein Merre*, it passes through the inaccessible defiles of Luristan, its course before reaching the *Kebir-Kuh* being a succession of rapids. Turned aside by this mountain, it follows for about 95 miles the depression which here exists as far as the foothills of Luristan, reaching the Susian plain as a torrent; but it becomes less rapid before losing itself in the marshes of *Hawizeh*. The course of the stream is said to be still doubtful in places.

In ancient times it flowed at the foot of the citadel of Susa, but its bed is now about 1½ miles to the W.

**3. Changed Bed at Susa** The date of this change of course (during which a portion of the ruins of Susa was carried away) is uncertain, but it must have been later than the time of Alexander the Great. The stream's greatest volume follows the melting of the snows in the mountains, and floods ensue if this coincides with the advent of heavy rain. Most to be dreaded are the rare occasions when it unites with the *Ab-e-Diz*.

The Ulai (Assyr *Ulāa* or *Uliāa*) near Susa is regarded as being shown on the sculptures of the Assyr king Ashur-bani-pal (Brit. Mus.,

**4. Assyrian References** Nineveh Gal.) illustrating his campaign against Te-umman. Its rapid stream bears away the bodies of men and horses, with chariots, bows and quivers. The

bodies which were thrown into the stream hindered its course, and dyed its waters with their blood.

LITERATURE.—See *Délégation en Perse: Mémoires*, I, *Recherches Archéologiques*, 25 ff.

T. G. PINCHES

**ULAM**, ū'lam (עֻלָּם, 'ullām, "preceding"):

(1) A "son" of Peresh; and a Manassite clan (1 Ch 7 16.17). Luc. reads Ἰλάμ, *Īlām*.

(2) A descendant of Benjamin who had sons, "mighty men of valor" (1 Ch 8 39.40). LXX B has Ἀλάμ, *Alām*, in ver 39, Ἀδέμ, *Adeim* in ver 40; A, Οὐλάμ, *Oulām*, in both, and so Luc.

**ULLA**, ul'a (עֻלָּא, 'ullā, meaning unknown): An Asherite (1 Ch 7 39).

**UMMAH**, um'a (עֻמָּה, 'ummāh; Ἀρχόβ, *Archób*, Ἀμμά, *Ammá*): One of the cities allotted to the tribe of Asher (Josh 19 30). By a slight emendation of the text it would read Acco, the name of the place subsequently known as Ptolemais, the modern *Akkā*. This emendation is generally adopted by scholars, although it is at best a conjecture. No other identification is yet possible.

**UMPIRE**, um'pīr. See **DAYSMAN**.

**UNBELIEF**, un-bē-lēf': The word (AV) represents two Gr words, ἀπειθεῖα, *apeitheia*, "disobedience" (only in Rom 11 30.32; He 4 6.11), and ἀπιστία, *apistia*, "distrust," the antithesis to "faith" (q.v.). The two words are not only akin etymologically but run into one another by mental connection, certainly where spiritual relations are concerned, as between man and God. For when God has spoken, in precept and yet more in promise, distrust involves, at least potentially, an element of disobedience. His supreme claim is to be trusted to command only what is right, and to promise only what is true. He is infinitely sympathetic in His insight, and infallibly knows where distrust comes only of the dim perceptions and weak misgivings of our mortal nature, and where, on the other hand, a moral resistance lies at the back of the non-confidence. But the presence of that darker element is always to be suspected, at least, and searched for in serious self-examination.

We may remark that it is a loss in our language that "unbelief" is the only word we can use as the antithesis to "faith"; for "faith" and "belief" (q.v.) are not exactly synonyms. "Unfaith" would be a welcome word for such use, if it were generally so understood. HANDLEY DUNELM

**UNBELIEVER**, un-bē-lēv'ēr: This word follows closely the lines of "unbelief" (q.v.) in its relation to originals. Once only (Acts 14 2) it represents the participle ἀπειθοῦντες, *apeithoúntes*, "disobeying [ones]." Elsewhere (nine cases) it represents ἀπιστος, *apistos*, "faithless," "without faith." In six of these passages (all in 1 and 2 Cor) it denotes the unconverted pagan as distinguished from the convert. In the other passages (Lk 12 46; Tit 1 15; Rev 21 8) the reference is to the unbelief which comes of moral resistance to God.

**UNCERTAIN**, un-sūr'tin, **UNCERTAINTY**, un-sūr'tin-ti: Adj. ἀδελος, *adēlos*, 2 Macc 7 34; 1 Cor 14 8; advb. ἀδέλως, 1 Cor 9 26; noun *adēlōtēs*, 1 Tim 6 17; *adēlos* means "not clear," and so "uncertain." Also AV Wisd 9 14 for ἐπισφαλής, *epispfalēs*, "unsteady," RV "prone to fall."

**UNCHANGEABLE**, un-chānj'a-b'l, **UNCHANGEABLENESS**, un-chānj'a-b'l-nēs:

I. UNCHANGEABLENESS OF GOD A TRUTH OF NATURAL THEOLOGY

## II. SCRIPTURAL DOCTRINE OF THE UNCHANGEABLENESS OF GOD

1. Not Lifeless Immobility
2. As Contrasted with the Finite
3. God's Knowledge, Will and Purpose
4. In His Relation to the World
5. His Relations to Men

### LITERATURE

The unchangeableness or immutability of God is that Divine attribute which expresses the truth that in His nature and perfections, in His knowledge, will and purpose, He always remains the same in the fulness of His infinite and perfect Being; infinitely exalted above change, becoming and development, which are the specific characteristics of all finite existence. This is one of what theologians have called the incommunicable attributes of God, that is, one of those specific characteristics of the Divine nature which make God to be God in distinction from all that is finite. These attributes have also been called negative attributes. By calling them negative, however, it is not meant that they express the nature of God in so far as He is unknowable and incomprehensible by the finite mind, while the positive attributes, such as love and righteousness, express God's nature as revealed and known. Both kinds of attributes can be known only in so far as God reveals Himself, and furthermore the so-called negative attributes involve a positive idea, while the positive ones in turn imply the negation of all finite limitations. Moreover, since the finite mind cannot comprehend the infinite God, back of all that God has revealed of Himself, back even of His absoluteness, eternity and unchangeability, lies the fulness of His infinite Being, unsearchable, unknowable, and incomprehensible alike in His nature and attributes (Ps 145 3; 147 5; Job 11 7-9; Isa 40 28).

It is these incommunicable attributes, including unchangeableness, which make God to be God, and mark the specific difference between Him and all finite existence. Unchangeableness is, therefore, the characteristic of God's entire nature and of all His attributes. It cannot be limited to His ethical nature or to His love, and, while it is true that these incommunicable attributes are revealed with especial richness in God's saving activity, they cannot be limited to marks of God's saving action or purpose. It is true that God is unchangeable in His love and grace and power to save, but that is only because it is the love and grace and power of the absolute, infinite and immutable God.

**I. Unchangeableness of God a Truth of Natural Theology.**—As the One infinitely perfect and absolute or self-existent Being, God is exalted far above the possibility of change, because He is independent, self-existent and unlimited by all the causes of change. As uncaused and self-existent, God cannot be changed from without; as infinitely perfect, He cannot suffer change from within; and as eternal and independent of time, which is the "form" of change and mutability, He cannot be subject to any change at all. God's unchangeableness, therefore, follows from His self-existence and eternity.

**II. Scripture Doctrine of the Unchangeableness of God.**—The Scripture doctrine of God reaffirms this truth. It conceives of God as a living Person in relation to the world and man, and at the same time as absolutely unlimited by the world and man, and as absolutely unchangeable. The God who has revealed Himself in the OT and the NT is never identified with, or merged in, the processes of Nature. He is complete and perfect in Himself, and is not the result of any process of self-realization. He is so great that His relations to the created universe cannot begin to exhaust His Being, and yet He stands in the closest relations to man and the world as Creator, Preserver, Governor, and Saviour.

On the one hand, then, the Bible never represents the unchangeableness of God as a dead immobility out of all relation to man and the world. This tendency of thought, **Lifeless Im-fearing anthropomorphism**, proceeds on the principle that to make any definite predications about God is to limit Him. The logical result of this is to conceive of God as abstract Being or Substance, so that the word "God" becomes only a name for the Unknowable. Over against this error, the Scripture represents God concretely as a Person in relation to the world and man. In the beginning He created the heavens and the earth, and from that time on He is the life of the world, esp. of Israel, His chosen people. To bring out this truth anthropomorphisms are employed. God comes and goes, reveals Himself and hides Himself. He repents (Gen 6 6; 1 S 15 11; Am 7 3; Joel 2 13); He becomes angry (Nu 11 1; Ps 106 40); and lays aside His anger (Dt 13 17; Hos 14 4). He sustains a different relation to the godly and the wicked (Prov 11 20; 12 22). In the fullness of time He became incarnate through the Son, and He dwells in His people by His Spirit, their experience of His grace being greater at some times than at others.

But on the other hand, the Scripture always asserts in unmistakable terms the unchangeableness of God. He is unchangeable in His nature. Although the name *'Ēl Shadday*, by which He made Himself known in the patriarchal period of revelation, denotes esp. God's power, this name by no means exhausts the revelation of God in that period. His unchangeableness is involved in His eternity as made known to Abraham (Gen 21 33). This attribute finds its clearest expression in the name "Jehovah" as revealed to Moses, the significance of which is unfolded in the passage Ex 3 13-15. God here reveals Himself to His people as "I AM THAT I AM," using the future tense of the vb. "to be," which, as the context shows, is given as the meaning of the name "Jehovah." Some recent writers would derive these words from the Hiphil stem of the vb., and affirm that it signifies that God is the giver of life. The vb., however, is in the Kāl stem, the tense denoting the changeless continuity of the life and nature of God. The idea expressed is not merely that of self-existence, but also of unchangeableness, and this unchangeableness, as the context clearly indicates (esp. ver 15), is here set forth not simply as belonging to the nature of God in Himself, but is brought into closest connection with His covenant relation to His people, so that the religious value of God's unchangeableness is most clearly implied in this fundamental assertion of the attribute. The same idea of God's immutability is reaffirmed in the prophecy of Isaiah. It is connected with the name *Jeh* (Isa 41 4; cf also 48 12), where *Jeh* affirms that He is the first and, with the last, the same God, thereby asserting not merely His eternity, but also that He is the same in His Divine existence throughout all ages. This attribute, moreover, is claimed by *Jeh*, and set forth as an especial mark of His Godhead in Isa 44 6. The unchangeableness of the Divine nature is also asserted by the prophet Malachi in a difficult passage (3 6). This is a clear affirmation of the unchangeableness of God, the only question being whether it is set forth as the ground of Israel's confidence, or in contrast with their fickleness, a question which depends partly on that of the text.

In the NT the thought of the passage in Ex 3 is reiterated in the Apocalypse where God is described as He who is and was and is to come (Rev 1 4). This is an expansion of the covenant name "Jehovah" in Ex 3 13-15, denoting not merely eternity but also immutability. The phrases "the Alpha and the

Omega" (Rev 1 8; 21 6; 22 13); and "the first and the last" (1 17; 22 13); and "the beginning and the end" (21 6; 22 13) bring out the same idea, and are applied to Christ as well as to God, which is a clear indication of Our Lord's Deity. The apostle Paul likewise asserts the incorruptibility, eternity and immortality of the Divine nature, all of which ideas imply the unchangeableness of God (Rom 1 23; 1 Tim 1 17; 6 16).

Not only is the unchangeableness of God's nature asserted in Scripture, and placed in relation to His dealings with men, but also it is declared to be the distinctive characteristic of God's nature as contrasted with the entire universe of finite being. While the heavens and the earth change and are passing away, God endures forever and forever the same God (Ps 102 26-28 [Heb 27-29]). The application of the language of this psalm to Christ by the author of the Ep. to the He (1 10-12) involves the unchangeableness of Christ, which is again explicitly asserted in this Ep. (13 8), being another clear indication of the way in which the Deity of Jesus Christ pervades the NT. This idea of God's immutability, as contrasted with the mutability of finite existence which is His creation, is given expression in the NT by the apostle James. As Creator of the heavenly bodies, God is called the Father of lights. While their lights, however, are intermittent, God's light is subject to neither change nor obscurity (1 17).

In accordance with this idea of the unchangeableness of God's nature, the Scripture, in ascribing life and personality to Him, never regards God as subject to any process of becoming or self-realization, and the views which so conceive of God are unscriptural whether they proceed upon a unitarian or a trinitarian basis.

God is also represented in Scripture as unchangeable in His knowledge, will and purpose. He is not a man that He should repent (1 S 15 29). His purposes, therefore, are unchangeable (Nu 23 19; Isa 46 11; Prov 19 21); and His decrees are accordingly likened to "mountains of brass" (Zec 6 1). His righteousness is as immutable as mountains (Ps 36 6 [Heb 7]); and His power also is unchangeable (Isa 26 4). Hence, while the Scripture represents God as sustaining living relations to His creatures, it does not conceive of Him as conditioned or determined in any way by men's acts, in either His knowledge, will, purpose or power. God knows eternally the changing course of events, and He acts differently upon different occasions, but all events, including human actions, are determined by God's unchangeable purpose, so that God's knowledge and actions are not contingent upon anything outside Himself.

Although, therefore, the idea of God as pure abstract Being, out of all relation to the world, is unscriptural, it is no less true that that conception of God which represents a reaction from this, and which conceives of God anthropomorphically and as conditioned and determined by the world and man, is also quite contradictory to the Scripture conception of God. This latter tendency goes too far in the opposite direction, and falls into the error of conceiving God's knowledge, will, purpose and power too anthropomorphically, and as limited by the free acts of man. While the opposite tendency kept God out of all relation to the world, this one erects God's relation to the world into something which limits Him. This way of conceiving of God, which is the error of Rationalism, Socinianism and Arminianism, is as unscriptural as that which conceives of God as abstract Being, unknowable, and entirely out of relation to the world.

Unchangeable in His nature and attributes, God is likewise unchangeable in His relation to the world, which relation the Scripture represents as creation and providence, and not as emanation. Hence while everything finite changes, God remains ever the same (Ps 102 26-28). Consequently the pantheistic idea is also unscriptural,

**2. As Contrasted with the Finite**

**3. God's Knowledge, Will and Purpose**

**4. In His Relation to the World**

which idea, going farther than the anthropomorphic and dualistic conception which places the world over against God, completely merges God's Being in the world and its processes of change, affirming that God comes to self-realization in the evolution of the world and man. In its reaction from the denial of God's living relation to the world, this view does not stop with limiting God by reason of this relation, but merges Him completely in the world-development. The Scripture, on the contrary, always conceives of God as immutably free and sovereign in His relation to all the creation.

In accordance with this idea of the unchangeableness of God's nature and attributes, the Bible always maintains God's absoluteness and transcendence of Nature and her processes in all of the relations which He sustains to the finite universe. It came into being by His creative fiat, not by any process of emanation from His Being. He sustains it in existence, and governs it, not by any process of self-realization in the series of second causes, but from without, by His sovereign will and power. And He intrudes into the series of finite causes miraculously, producing events in Nature which are due solely to His power. When for man's salvation the Son of God became incarnate, it was not by any change of His nature in laying aside some or all of the attributes of Deity, but by assuming a human nature into personal union with the Divine nature. The Scripture passages which speak of the incarnation of Our Lord clearly indicate that the Son retained His full Deity in "becoming flesh" (cf esp. the prologue to John's Gospel and Phil 2 6-8). Moreover, the OT doctrine of the Spirit of God as the source of life to the world is always at pains to avoid any mingling of the Spirit with the processes of Nature, and the same thing is true of the NT doctrine of the indwelling of the Spirit in the believer, always keeping the Spirit distinct from the spirit of man (Rom 8 16).

Finally, God is unchangeable not only in relation to the universe, but in His relations to men and esp. to His people. This follows from His unchangeable ethical nature. The Scripture often connects the unchangeableness of God with His goodness (Ps 100 5; Jas 1 17); with His truthfulness and mercy (Ps 100 5; 117 2); and with His covenant promises (Ex 3 13 ff). In connection with His covenant promises, God's unchangeableness gives the idea of His faithfulness which is emphasized in the OT to awaken trust in God (Dt 7 9; Ps 36 5 [Heb 6]; Ps 92 2 [Heb 3]; Isa 11 5; Lam 3 23). This idea of God's unchangeableness in His covenant promises or His faithfulness is repeated and emphasized in the NT. His gifts or graces and election are without repentance (1 Thess 5 24; Rom 11 29); He is faithful toward men because unchangeably true to His own nature (2 Tim 2 13); His faithfulness abides in spite of men's lack of faith (Rom 3 5), and is in many places represented as the basis of our confidence in God who is true to His election and gracious promises (1 Cor 1 9; 10 13; 2 Thess 3 3; He 10 23; 11 11; 1 Pet 4 19; 1 Jn 1 9). See FAITHFULNESS. It is thus the religious significance and value of God's unchangeableness which is esp. emphasized throughout the Scripture. Because He is unchangeably true to His promises, He is the secure object of religious faith and trust, upon whom alone we can rely in the midst of human change and decay. It is this idea to which expression is given by calling God a rock, the rock of our strength and of our salvation (Dt 32 15; Ps 18 2 [Heb 3]; 42 9 [Heb 10]; 71 3; Isa 17 10). God is even eternally a rock, the never-failing object of confidence and trust (Isa 26 4).

It appears, therefore, that the Scripture idea of the unchangeableness of God lays emphasis upon four points. First, it is not lifeless immobility, but the unchangeableness of a living Person. Second, it is, however, a real unchangeableness of God's nature, attributes and purpose. Third, this unchangeableness is set forth as one of the specific characteristics of Deity in distinction from all that is finite. Fourth, God's unchangeableness is not dealt with in an abstract or merely theoretic manner, but its religious value is invariably emphasized as constituting God the one true object of religious faith.

LITERATURE.—Besides the comms. on appropriate passages, and the discussion of the Divine attributes in the general works on systematic theology, see Dillmann, *Handbuch der alttest. Theol.*, 1895, 15-20, 243-44; Oehler, *Theol. of the OT*, ET, 1883, 95, 100; Schulz, *Alttest. Theol.*, 1896, 419; Davidson, *The Theol. of the OT*, 1904, 45-58, 165. For a fuller discussion see Char-nock, "The Immutability of God," *Works*, vol. I, 374-419; Dörner, *Ueber die richtige Fassung des dogmatischen Begriffs der Unveränderlichkeit Gottes*, u.s.w., Article I, "Die neueren Längnungen der Unveränderlichkeit des persönlichen Gottes, u.s.w.," *JDT*, I, 201-77; II, "Die Geschichte der Lehre von der Unveränderlichkeit Gottes bis auf Schleiermacher," *JDT*, II, 440-500; III, "Dogmatische Erörterung der Lehre von der Unveränderlichkeit Gottes," *JDT*, III, 579-660; H. Cremer, *Die christliche Lehre von den Eigenschaften Gottes*, 1897, pub. in the *Beiträge zur Förderung christlicher Theol.*, I, 7-111; see pp. 10 ff, and esp. pp. 102-9.

CASPAR WISTAR HODGE

**UNCHASTITY**, un-chas'ti-ti. See CRIMES; PUNISHMENTS.

**UNCIRCUMCISED**, un-sūr'kum-sīzd, **UNCIRCUMCISION**, un-sūr-kum-sīzh'un: The adj. in the OT is עָרֵל, 'ārēl (Gen 17 14, etc), from a root of uncertain meaning, with the noun עֲרֻלָּה, 'orlāh, "uncircumcised [person]" (Lev 19 23; Jer 9 25), and the vb. עָרַל, 'āral, "count as uncircumcised" (Lev 19 23; RV Hab 2 16). In Apoc and the NT the noun is ἀκροβυστία, akrobustia (a physiological term, 1 Macc 1 15; Acts 11 3, etc), and the adj. ἀπερίτμητος, aperitmetos (Ad Est 14 15; 1 Macc 1 48; 2 46; Acts 7 51), with the vb. ἐπισπάσμαι, epispāomai, "become uncircumcised" (1 Cor 7 18). The language of 1 Macc 1 15 suggests the performance of some surgical operation, but no such operation appears to be possible, and "behaved like uncircumcised persons" (as in 1 Cor 7 18) is the probable meaning. See CIRCUMCISION.

BURTON SCOTT EASTON

**UNCLE**, un'k'l (דֹּדָה, dōdh, "beloved," "uncle," "relation"). See RELATIONSHIPS, FAMILY.

**UNCLEAN**, un-klēn', **SPIRIT**. See SPIRIT, UNCLEAN; DEMON, DEMONIC.

**UNCLEANNESS**, un-klēn'nes:

I. TERMS

1. In the OT
2. In the NT
3. In LXX

II. POSSIBLE RELATION OF ISRAEL'S LAWS ON UNCLEANNESS WITH THE LAWS OF TABOO AMONG THE NATIONS

III. TEACHING AS TO UNCLEANNESS

1. In the OT
2. In the Apoc
3. In the NT

LITERATURE

I. Terms.—טְמֵאָה, tum'ah, "uncleaness," "defilement," occurs 26 t (Lev 7 20, 21; 14 19; 15 3, 25, 26, 30, 31, etc). נִדְחָה, niddah, "separation."

1. In the OT "impurity," occurs in Lev 20 21; Ezr 9 11; Zec 13 1. עֲרֻלָּה, 'erwāh, occurs in (Hebrew) Dt 23 14. עֲרֻלָּת דָּבָר, 'erwath dābhār, "unclean thing" (Dt 24 1), is tr'd "uncleaness" in AV. The adj. טְמֵאָה, tamē', "defiled," "unclean," occurs 72 t (over half in Lev), but is never tr'd "uncleaness," but always "unclean." The vb. טָמַא, tamē', "to make" or

"declare unclean," occurs often. Other Heb vbs. "to defile" are אָפַת, *ga'al*, הָלַל, *h'alal*, הָנֵפֵחַ, *han'eph*, פָּנָה, *fanaph*, עָלַל, *'alal*, עָנָה, *'anah*.

The Gr word for "uncleanness" is ἀκαθάρσια, *akatharsia*, which occurs 10 t (Mt 23 27; Rom 1 24; 6 19; 2 Cor 12 21, etc). μiasμός, *miasmós*, "pollution," occurs only in 2 Pet 2 10.

**2. In the NT** The adj. ἀκάθαρτος, *akáthartos*, "unclean," occurs 31 t, 23 t in reference to unclean spirits (Lk once using the expression "unclean demon," 4 33), 4 t to ceremonial uncleanness (three by Peter and one by John the revelator), and 4 t to moral uncleanness (three by Paul and one by John the revelator). κοινός, *koínos*, "common," "unclean," occurs 8 t in the sense of "unclean" (Mk 7 2,5; Acts 10 14,28; 11 8; Rom 14 14; Rev 21 27). The vb. κοινῶ, *koínō*, "to defile," occurs 11 t (Mt 15 11,18; 20; Mk 7 15, etc). μαιίνω, *maiínō*, "to defile," occurs 5 t (Jn 18 28; Tit 1 15; He 12 15; Jude ver 8). μολύνω, *molúnō*, "to make filthy," occurs 3 t (1 Cor 3 7; Rev 3 4; 14 4). σπιλάω, *spiláo*, "occurs twice (Jas 3 6; Jude ver 23) and φθείρω, *phthérō*, "to corrupt," occurs 7 t in Gr, once in EV (1 Cor 3 17).

*Akatharsia*, "uncleanness," occurs 59 t in LXX (including many instances in apocryphal books) (1 and 2 Esd., Tob, 1 and 2 Macc, etc). *Akathartos*, "unclean," occurs 134 t in LXX (including one example in 1 Macc). *Koínos*, "unclean," and *koínō*, "to make unclean," occur, in Est, Prov, Wisd, 1, 2, 3 and 4 Macc). *Maiínō*, "to defile," occurs over 100 t. *Molúnō*, "to make filthy," occurs 18 t (both in the OT and in Apoc).

**3. In LXX** "unclean," and *koínō*, "to make unclean," occur, in Est, Prov, Wisd, 1, 2, 3 and 4 Macc). *Maiínō*, "to defile," occurs over 100 t. *Molúnō*, "to make filthy," occurs 18 t (both in the OT and in Apoc).

**II. Possible Relation of Israel's Laws on Uncleanness with Laws of Taboo among the Nations.**

—W. R. Smith (*Lectures on the Religion of the Semites*, 152-55) thinks there is a kinship between Israel's laws of uncleanness and the heathen taboo. Frazer, in *The Golden Bough*, shows numerous examples of the taboo among various tribes and nations which present striking similarity to some of Israel's laws on uncleanness. But does this diminish our respect for the OT laws on uncleanness? Might not Jeh use this natural religious perception of men as to an intrinsic distinction between clean and unclean in training Israel to a realization of a higher conception—the real difference between sin and holiness, i.e. between moral defilement and moral purification? The hand of Jeh is visible even in the development of Israel's rudimentary laws on ceremonial uncleanness. They are not explicable on purely naturalistic grounds, but Jeh is training a people to be holy, and so He starts on the lower plane of ceremonial uncleanness and cleanness (see Lev 11 44 as to the purpose of Jeh in establishing these laws respecting clean and unclean animals).

**III. Teaching as to Uncleanness.**—Each term above for uncleanness is used in two senses: (a) to signify ceremonial uncleanness, which

**1. In the OT** is the most usual significance of the term in the OT; (b) but, in the Prophets, to emphasize moral, rather than ceremonial, uncleanness. There are four principal spheres of uncleanness in the OT:

(1) *Uncleanness in the matter of food.*—The law as to clean and unclean beasts is laid down in Lev 11 1-23. Notice that the law does not extend to vegetable foods, as does a similar law in the Egypt religion. Four kinds of beasts are named as fit for food: (a) among quadrupeds, those that both chew the cud and part the hoof; (b) among fishes, only those having both fins and scales; (c) most birds or fowls, except, in the main, birds of prey and those noted for uncleanness of habits, are permitted; (d) of insects those that have legs above the feet to leap withal (e.g. the cricket, the grasshopper, etc), but those that go on all four, or have many feet, or go upon the belly (e.g. worms, snakes, lizards, etc), are forbidden. See, further, Food.

(2) *Uncleanness connected with the functions of reproduction (Lev 12 and 15).*—In Lev 15 2-18, we find the laws applied to issues of men; in 15 19 ff, to the issues of women. Not only is the man

or woman unclean because of the issue, whether normal or abnormal, but the bed on which they lie, or whatever or whoever is touched by them while they are in this state, is unclean. The uncleanness lasts seven days from the cessation of the issue. To become clean men must wash their clothes and bathe their bodies (though this requirement is not made of women), and both men and women must offer through the priest a pair of turtle-doves, or two young pigeons (Lev 15). According to Lev 13, the woman who conceives and bears a child is unclean. This uncleanness lasts seven days if the child born is a male, but 14 days if the child is a female. However, there is a partial uncleanness of the mother that continues 40 days from the birth of a male, 80 days from the birth of a female, at the end of which period she is purified by offering a lamb and a young pigeon (or turtle-dove), or if too poor to offer a lamb she may substitute one of the birds for the lamb.

(3) *Uncleanness connected with leprosy.*—According to Lev 14 and 15, the leper was regarded as under the stroke of God, and so was deemed unclean. The leper (so adjudged by the priest) must separate himself from others, with torn clothes, disheveled hair, and crying with covered lips, "Unclean! Unclean!" That is, he was regarded as a dead man, and therefore unclean and so must live secluded from others. See, further, LEPROSY, LEPROSY.

(4) *Uncleanness associated with death.*—According to Lev 15 24-40, anyone who touched a dead beast, whether unclean or clean, was rendered unclean. According to Nu 19 11-22, anyone touching the corpse of a human being is unclean. Likewise, everyone in the tent, or who enters the tent, where lies a dead man, is unclean seven days. Even the open vessels in the tent with a dead person are unclean seven days. Whoever, furthermore, touched a dead man's bone or grave was unclean seven days. Purification, in all these cases of uncleanness as related to death, was secured by sprinkling the ashes of a red heifer with living water upon the unclean person, or object, on the 3d and 7th days. See PURIFICATION.

In Tob 3 7-9; 6 13,14; 7 11; 8 1-3; 1 Macc 1 41-53, and in other books, we find the same laws on uncleanness recognized by the descendants of Abraham. It was regarded as abominable to sacrifice other animals (swine for instance) than those prescribed by Jeh.

**2. In the Apoc** There is a growing sense in Israel during this period, that all customs and all conduct of the heathen are unclean. Witness the resistance of the loyal Jews to the demands of Antiochus Epiphanes (1 Macc 1, 2, 6, 7). The sense of ceremonial uncleanness was still a conspicuous element in the religious consciousness of the Jews in the inter-Bib. period. But the training of God in ceremonial purification and in the moral and spiritual teachings of the prophets had prepared the way for an advance in moral cleanness (both in thought and in practice).

By the days of Jesus the scribes and rabbis had wrought out a most cumbrous system of ceremonial uncleanness and purification. Nor did they claim that all their teachings on this subject were found in the OT. See TRADITION. This is fitly illustrated in the NT in the washing of hands. See UNWASHEN. When the Mish (the collection of rabbinic teachings) was produced, the largest book was devoted to the laws of purification, 30 chapters being used to describe the purification of vessels alone.

See Jn 2 1-11, and note how the Jews had six stone waterpots for purification at the wedding in Cana. See Jn 3 25 as to the controversy on purification between John's disciples and the Jews. This question of cleanness and uncleanness was a tremendous issue with every Jew. He must keep himself



ceremonially clean if he would be righteous and win the approval of God.

Jesus utterly disregarded for Himself these laws of purification, though He orders the cleansed leper to return to the priest and secure his certificate of cleansing. He did not wash His hands before eating, and His disciples followed His example. Therefore the Pharisees challenged Him to give an account of His course and that of His disciples (Mt 15 3-20=Mk 7 6-23). Jesus then enunciated the great principle that there is no ceremonial, but only moral and spiritual, uncleanness. Not what goes into a man from hands that touch unclean things defiles the man, but the things that come out of his heart, evil thoughts, hatred, adultery, murder, etc. those defile the man.

Paul likewise regarded nothing as unclean of itself (Rom 14 14,20; Tit 1 15), yet no man should violate the scruples of his own conscience or that of his brother (and thus put a stumbling-block in his way). Love, not ceremonialism is the supreme law of the Christian. Paul, in submitting to the vow of purification in Jerus, set an example of this principle (Acts 21 26). See also CRIMES; PUNISHMENTS.

LITERATURE.—W. R. Smith, *Lectures on the Religion of the Semites* (esp. pp. 152-55, on taboo, and pp. 455, 456, on the uncleanness of sexual intercourse); Frazer, *The Golden Bough* (examples of taboo and similar laws and customs among various nations); Frazer, art. "Taboo" in *Enc Brit.*, 9th ed.; Benzinger, *Heb Archaeology*; Nowack, *Heb Archaeology*; Kellogg, comm. on "Lev" (*Expositor's Bible*); Kalisch, *Leviticus*; Dillmann-Ryssel, *Leviticus*; Schultz, Dillmann, Smend, Marti, Davidson, in their OT Theologies, give useful hints on this subject; art. "Casuistry" (Heb) in *ERE*, III, is valuable.

CHARLES B. WILLIAMS

**UNCLOTHED**, un-klōthd'. See CLOTHED UPON.

**UNCTION**, unk'shun: The AV tr of *χρίσμα*, *chrisma* (1 Jn 2 20), which RV renders "anointing," as AV renders the same word in 1 Jn 2 27.

**UNDEFILED**, un-dē-fild': In the OT *טָמֵא*, *tām*, "perfect," presents the positive side. Hence Ps 119 1 is tr'd in RV: "Blessed are they that are perfect in the way." In the NT *ἀμύαντος*, *amiantos*, presents the negative side, "unstained," "unsullied," "without taint." Used to describe the sinlessness of Christ (He 7 26), to declare the marriage act free from all guilt, disgrace or shame (He 13 4), to contrast the heavenly inheritance with earthly possessions (1 Pet 1 4).

**UNDERGIRDING**, un-dēr-gūrd'ing. See SHIPS AND BOATS, III, 2.

**UNDERNEATH**, un-dēr-nēth' (תַּחַת, *tahath*, "the bottom [as depressed]"): "Underneath are the everlasting arms" (Dt 33 27). In these words Moses sums up the history of Israel and gives expression to his final thought about life and time and all things visible. Underneath all phenomena and all the chances and changes of life and time there is unchanging law, everlasting principle, an all-enfolding power, an all-embracing love.

**UNDERSETTER**, un'dēr-set-ēr (כַּתְּמֵפֶה, *kāthēph*): The word, used in 1 K 7 30,34 of supports of the laver, means lit. "shoulder," and is so rendered in RVm. See LAVER.

**UNDERTAKE**, un-dēr-tāk': "To take upon one's self," "assume responsibility," and so in Elizabethan Eng. "be surety." In this sense in AV Isa 38 14, "O Lord, . . . undertake for me" (עָרַב, *'arabh*, RV "be thou my surety"). Perhaps in the same sense in Sir 29 19, although the idea is

scarcely contained in the Gr vb. *διώκω*, *diōkō*, "pursue." In the modern sense in 1 Esd 1 28; 2 Macc 2 29; 8 10; AV 2 27. See SURE; SURETY.

**UNEQUAL**, un-ē'kwāl: Ezk 18 25,29 for *לֹא הֵכֵן*, *lō' thākhan*, "not weighed," "illogical." "Unequally" in 2 Cor 6 14, in the phrase "unequally yoked," *ἑτεροζυγέω*, *heterozugéō*, is used of the yoking together of two animals of different kinds (cf LXX of Lev 19 19).

**UNFEIGNED**, un-fānd' (ἀνυπόκριτος, *anupōkritos*, "unfeigned," "undisguised"): The Gr word occurs only in the NT (1 Tim 1 5; 2 Tim 1 5) and is designative of the moral-quality of faith as "the mark of transparency and simplicity of soul—the most complete and distinct exponent of a man's character—the natural hypothesis of a pure and good heart—a readiness to believe in goodness" (Martineau, *Hours of Thought*, First Series, 86 ff). Cf 2 Cor 6 6; 1 Pet 1 22; Jas 3 17.

**UNGODLY**, un-god'li (ἄσέβης, *rāshā'* [Ps 1 1], "wicked," *בְּלִיַּעַל*, *beliya'al* [2 S 22 5], "worthless"; in the NT *ἀσεβής*, *asebēs* [Rom 5 6], e.g. indicating that the persons so called are both irreverent and impious): Trench says that the idea of active opposition to religion is involved in the word, that it is a deliberate withholding from God of His dues of prayer and of service; a standing, so to speak, in battle array against God and His claims to respect, reverence and obedience. Those whose sins are particularly aggravating and deserving of God's wrath are the "ungodly." And yet it is for such that Jesus Christ died (Rom 5 6).

WILLIAM EVANS

**UNICORN**, ū'ni-kōrn (אֶבְרַתָּא, *r'ēm* [Nu 23 22; 24 8; Dt 33 17; Job 39 9,10; Ps 22 21; 29 6; 92 10; Isa 34 7]): "Unicorn" occurs in AV in the passages cited, where RV has "wild-ox" (q.v.).

**UNITY**, ū'ni-ti: Ps 133 1 for *יָחַד*, *yāhadh*, "unitedness," and Eph 4 3,13 for *ἐνότης*, *henōtēs*, "oneness." Also Sir 25 1 AV for *ὁμόνοια*, *homōnoia*, "concord" (so RV).

**UNKNOWN**, un-nōn', GOD (ἄγνωστος θεός, *agnōstos theós*): In Acts 17 23 (St. Paul's speech in Athens) ARV reads: "I found also an altar with this inscription, TO AN UNKNOWN GOD. What therefore ye worship in ignorance, this I set forth unto you." AV and ERVm translate "to the Unknown God," owing to the fact that in Gr certain words, of which *theós* is one, may drop the art. when it is to be understood. In the present case the use of the art. is probably right (cf ver 24). In addition, AV reads "whom" and "him" in place of "what" and "this." The difference here is due to a variation in the Gr MSS, most of which support AV. But internal probability is against AV's reading, as it would have been very easy for a scribe to change neuters (referring to the Divine power) into masculines after "God," but not vice versa. Hence modern editors (except von Soden's margin) have adopted the reading in RV.

St. Paul in Athens, "as he beheld the city full of idols," felt that God was truly unknown there. Hence the altar with the inscription struck him as particularly significant. Some Athenians, at any rate, felt the religious inadequacy of all known deities and were appealing to the God who they felt must exist, although they knew nothing definite about Him. No better starting-point for an address could be wished. What the inscription actually meant, however, is another question. Nothing is known about it. Altars dedicated "to unknown gods" (in the pl.) seem to have been fairly

common (Jerome on Tit 1 12; Pausanias, i.1.4; Philaster, *Vita Apoll.*, vi.3), and Blass (*Comm.* ad loc.) has even suggested that the words in Acts were originally in the pl. But this would spoil the whole point of the speech, and the absence of references to a single inscription among thousands that existed can cause no surprise. Those inscriptions in the pl. seem to have been meant in the sense "to the other deities that may exist in addition to those already known," but an inscription in the sing. could not have this meaning. Perhaps a votive inscription is meant, where the worshipper did not know which god to thank for some benefit received. That a slur on all the other Athenian objects of worship was intended is, however, most improbable, but St. Paul could not of course be expected to know the technical meaning of such inscriptions. See ATHENS.  
BURTON SCOTT EASTON

**UNLEARNED**, un-lûr'ned: Acts 4 13 for ἀγράμματος, *agrámmatos*, lit. "illiterate." But nothing more than "lacking technical rabbinical instruction" seems to be meant (cf Jn 7 15). 1 Cor 14 16.23.24 for ἰδιώτης, *idiotēs*, "private person," RVm "he that is without gifts," correctly expresses the sense ("unbeliever" is hardly in point); also AV 2 Tim 2 23; 2 Pet 3 16 (RV "ignorant").

**UNLEAVENED**, un-lev'nd. See LEAVEN; PASSOVER; SACRIFICE IN THE OT.

**UNNATURAL VICE**, un-na'tû-ral vîs. See CRIMES; PUNISHMENTS.

**UNNI**, un'î (יְנִי, 'unnî, meaning unknown):

(1) One of "the twelve brethren" (so Curtis for RV "brethren of the second degree") appointed as singers (1 Ch 15 18.20).

(2) In Neh 12 9 (K<sup>e</sup>-thibh יְנִי, 'unnî) = RV UNNO (q.v.).

**UNNO**, un'ô (יְנִי, 'unnî; LXX omits the name, but in N a later hand has added Ἰανᾶ, *Ianâ*; the K<sup>e</sup>-rê of the MT has יְנִי, 'unnî, as in 1 Ch 15 18, whence AV "Unni"): A Levite who returned with Zerubbabel (Neh 12 9).

**UNPARDONABLE**, un-pâr'd'n-a-b'l, SIN. See BLASPHEMY.

**UNQUENCHABLE**, un-kwench'a-b'l, FIRE (πῦρ ἄσβεστος, *pûr âsbestos*): The phrase occurs in Mt 3 12 and its || Lk 3 17 in the words of the Baptist on the Messianic judgment: "The chaff he will burn up with unquenchable fire"; but also on the lips of Christ Himself in Mk 9 43, where the "unquenchable fire" is equated with "Gehenna" (q.v.). The same idea lies in ver 48, "The fire is not quenched" (*ou sbénntai*), and is implied in the numerous allusions to fire as the instrument of punishment and destruction in the Gospels and other parts of the NT (e.g. "the Gehenna of fire," Mt 5 22 m, etc.; "furnace of fire," Mt 13 40.42.50; "eternal fire," Mt 25 41; cf also 2 Thess 1 8; 2 Pet 3 7; Jude ver 7; Rev 19 20; 20 10.14.15; 21 8). For OT analogies cf Isa 1 31; 34 10; 66 24; Jer 4 4; 7 20; 17 27; 21 12; Ezk 20 47.48. The language is obviously highly metaphorical, conveying the idea of an awful and abiding judgment, but is not to be pressed as teaching a destruction in the sense of annihilation of the wicked. An unquenchable fire is not needed for a momentary act of destruction. Even in the view of Rev. Edward White the wicked survive the period of judgment to which these terms relate. See PUNISHMENT; EVERLASTING.

JAMES ORR

**UNTEMPERED**, un-tem'pêrd (תַּפְּחָל, *tâphâl*): Used of mortar in Ezk 13 10-15; 22 28. *Tâphâl* probably refers to mortar made with clay instead of slaked lime. In the interior of Pal and Syria walls are still commonly built of small stones or mud bricks, and then smeared over with clay mortar. The surface is rubbed smooth and is attractive in appearance. This coating prolongs the life of the wall but requires yearly attention if the wall is to stand.

Ezekiel uses the practice to typify the work of false prophets. They build up stories and make them plausible by an outward semblance to truth, while, in fact, they are flimsy, unreliable prophecies, resembling the walls described above, which can be broken down by a push or a heavy rain storm.

JAMES A. PATCH

**UNTOWARD**, un-tô'êrd, un-tôrd' (σκολιός, *skoliós*): Appears only in Acts 2 40, AV "Save yourselves from this untoward generation." It means "perverse," "wilful," "crooked," and is so tr'd in RV: "this crooked generation" (*apó tês geneás tês skoliás taritês*). AV headings to Isa 28 and Hos 6 have "untowardness." This now obsolete term probably derived its origin from the idea of the heart that was not inclined toward the Divine will and teaching. Hence "not-toward," or "untoward."

**UNWALLED**, un-wôld'. See VILLAGE; WALL.

**UNWASHEN**, un-wosh'n (ἀνίπτος, *ániptos*): Occurs only twice in the NT, not at all in the Heb or Gr OT (Mt 15 20 = Mk 7 2). Jesus is here denouncing the traditionalism of the scribes and Pharisees. Uncleanness, to them, was external and purification was ceremonial. Hence the Pharisaic view that the hands became unclean (religiously, not physically), and so before meals must be cleansed (religiously) by washing, which consisted in two affusions and must extend up to the wrist, else the hand was still unclean. Jewish tradition traced this custom back to Solomon (see *Shabbath 14b*, end), but the first unmistakable occurrence of the custom is in the Sib Or (3 591-93), where the hands are said to be washed in connection with prayer and thanksgiving. The schools of Shammai and Hillel, though usually differing on points of tradition, agreed on the washing of hands as necessary for ceremonial purification (having reached this agreement in the early part of Jesus' life). See PURITY; UNCLEANNES.

LITERATURE.—Broadus, *Comm.* on Mt (15 2-20); Gould, Swete, *comms.* on Mk (7 2); Edersheim, *The Life and Times of Jesus the Messiah*, II, 8 ff; Schürer, *HJP*, div II, vol I, §25 ("Scribism").

CHARLES B. WILLIAMS

**UNWORTHILY**, un-wûr'thi-li: 1 Cor 11 27.29 AV for ἀνάξιος, *anaxiós*. In ver 29, RV, on convincing textual evidence, has omitted the word, which is a needless gloss (cf RV's tr of the whole verse). In ver 27 ARV has changed "unworthily" to "in an unworthy manner," a rather pointless alteration.

**UNWRITTEN**, un-rit'n, SAYINGS. See AGRAPHA.

**UPHARSIN**, û-fâr'sin (יְפָרְסִין, *ûpharšîn*). See MENE, MENE, TEKEL, UPHARSIN.

**UPHAZ**, û'faz (יְפָז, 'ûphâz): A gold-bearing region, mentioned in Jer 10 9; Dnl 10 5, otherwise unknown. Perhaps in both passages Ophir, which differs in one consonant only, should be read. In the second passage, instead of "gold of Uphaz," perhaps "gold and fine gold" ('ûphâz) should be

read. The Jerus Talm states that there were seven kinds of gold, good gold, pure, precious, gold of Uphaz, purified, refined, and red gold of Parvaïm (2 Ch 3 6). That of Uphaz, which is so called from the place from which it comes, resembles "flashes of fire fed with pitch" (M. Schwab, *The Talmud of Jerusalem*, V, 207 f).

THOMAS HUNTER WEIR  
**UPPER CHAMBER**, up'ēr chām'bēr, **UPPER ROOM** (חַמְרֵי הַיָּמִין, 'āliyāh [2 K 1 2], etc; ἀνώγειον, *anōgeion* [Mk 14 15; Lk 22 12], ὑπερῶνον, *hyperōnon* [Acts 1 13; 9 37.39; 20 8]): In Jgs 3 20 ERV renders "summer parlor" and in m "Heb 'Upper chamber of cooling.'" This was probably a roof-chamber. The "upper chamber" of Ahaziah in 2 K 1 2 was evidently in the 2d story of the building. On the "upper chambers" of the temple (1 Ch 28 11; 2 Ch 3 9), see **TEMPLE**. The "large upper room" which was the scene of the Last Supper, with that in Acts 1 13, was also plainly an upper-story chamber. That in Acts 20 8 was in the 3d story (at Miletus, a Gr city). See also **HOUSE**.

JAMES ORR

**UR**, ūr (אִרַּר, 'ūr, "flame"; B, Σθῦρ, *Sthūr*, ἄ, 'Ἄρα, *Ōrā*): Father of Eliphai, one of David's "mighty men," in 1 Ch 11 35; in the || 2 S 23 34 called "Ahasbai."

**UR OF THE CHALDEES**, kal'dēz (אִרַּר בְּכַשְׁדִּים, 'ūr kasdīm; ἡ χώρα [τῶν] Χαλδαίων, *hē chōra [tōn] Chaldaiōn*): For more than 2,000 years efforts have been made to identify the site of this city. The writers of the LXX, either being unfamiliar with the site, or not considering it a city, wrote *chōra*, "land," instead of Ur. Eupolemus, who lived about 150 BC, spoke of it as being a city of Babylonia called Camarina, which he said was called by some Ouria. St. Stephen (Acts 7 2.4) regarded the place as being in Mesopotamia. The Talm, however, as well as some later Arab. writers, regarded Erech (LXX Ὀρεκ, *Ōrek*) as the city. The cuneiform writing of this city, Uruk, would seem to support this view, but Erech is mentioned in Gen. Ammianus Marcellinus identified the city with the castle of Ur in the desert between Hatra and Nisibis, but this was only founded in the time of the Persians. Owing to its nearness to Haran, and because St. Stephen placed it in Mesopotamia, Urfa or Oorfa, named Edessa by the Greeks, has also in modern times been identified as the city. But Seleucus is credited with having built this city.

The most generally accepted theory at the present time is that Ur is to be identified with the modern *Mugheir* (or *Mughayyar*, "the pitchy") in Southern Babylonia, called Urumma, or Urima, and later Urū in the inscriptions. This borders on the district which in the 1st millennium BC was called Chaldaea (*Kaldā*).

This, some hold, accords with the view of Eupolemus, because Camarina may be from the Arab. name of the moon *qamar*, which refers perhaps to the fact that the ancient city was dedicated to the worship of the moon-god. Another argument which has been advanced for this identification is that Haran, the city to which Terah migrated, was also a center of moon-god worship. This, however, is precarious, because Urumma or Urima in Abraham's day was a Sumerian center, and the seat of Nannar-worship, whereas Haran was Semitic, and was dedicated to Sin. Although these two deities in later centuries were identified with each other, still the argument seems to have little weight, as other deities were also prominently worshipped in those cities, particularly Haran, which fact reminds us also that the Talm says Terah worshipped no less than 12 deities.

It should be stated that there are scholars who hold, with the LXX, that Ur means, not a city, but perhaps a land in which the patriarch pastured his flocks, as for instance, the land of Uri or Ura (Akkad). The designation "of the Chaldaeans" was in this case intended to distinguish it from the land where they were not found.

Still another identification is the town Ūru (Mar-tu) near Sippar, a place of prominence in the time of Abraham, but which was lost sight of in subsequent periods (cf *Amurru*, 167). This fact would account for the failure to identify the place in the late pre-Christian centuries, when Urima or Urū still flourished. Western Semites—for the name Abram is not Bab—lived in this city in large numbers in the age when the patriarch lived. The Bab contract lit. from this, as well as other sites, is full of names from the western Sem lands, Aram and Amurru. This fact makes it reasonable that the site should be found in Babylonia; but, as stated, although the arguments are by no means weighty, more scholars at the present favor *Mugheir* than any other site.

A. T. CLAY

**URBANE**, ūr'bān, -bān'. See **URBANUS**.

**URBANUS**, ūr-bā'nus (Οὐρβανός, *Ourbanós*; AV **Urbane**): A common slave name. Gifford says that it is found "as here, in juxtaposition with Ampliatus, in a list of imperial freedmen, on an inscription, 115 AD." He was a member of the Christian community at Rome to whom Paul sent greetings. Paul calls him "our fellow-worker in Christ" (Rom 16 9). "The 'our' (as opposed to 'my,' ver 3) seems to suggest that all Christian workers had a common helper in Urbanus" (Denney).

**URI**, ū'ri, dō'ri (אִרִּי in 1 K 4 19), 'ūrī, "fiery," unless the word be contracted for אִרְיָהּ, 'ūriyāh, "Uriah"):

(1) Son of Hur, and father of Bezalel (Ex 31 2; 35 30; 38 22; 1 Ch 2 20; 2 Ch 1 5).

(2) Father of Geber, one of Solomon's 12 provision officers (1 K 4 19; LXX B A, 'Adal, *Adat*).

(3) A porter who had married a foreign wife (Ezr 10 24; LXX B A, 'Ἄδοῦθ, *Ōdoúth*, A, 'Ἄδοῦθ, *Ōdoúth*, Luc., *Oúplas*, *Ourias*).

**URIAH**, ū-rī'a, **URIJAH**, ū-rī'ja (אִרְיָהּ, 'ūriyāh, in Jer 26 20 אִרְיָהּ, 'ūriyāhū, "flame of Jeh" or "my light is Jeh"; LXX and NT Οὐρ[ε]ίας, *Our[e]ias*, with variants; AV has Urijah in 2 K 16 10-16; Neh 3 4.21; 8 4; Jer 26 20):

(1) A Hittite, who had settled in Jerus at the time of David and who had entered David's service. He had become a worshipper of Jeh (judging from the usual interpretations of his name) and had married a Heb wife, BATH-SHEBA (q.v.). David's sin with this woman occurred while Uriah was engaged in warfare, and David had him recalled to Jerus in order to hide what had transpired. Uriah, however, felt himself bound by the consecration of a soldier (cf 1 S 21 5; Dt 23 10 f) and refused to do violence to his religion, so that David's ruse was in vain. (The point is missed here by speaking of Uriah's "chivalrous determination," as in *HDB*, IV, 837.) David, in desperation, wrote Joab instructions that were virtually a command to have Uriah murdered, and these instructions were duly carried out (2 S 11 2-27). The inclusion of Uriah's name in the list of the "mighty men" in 2 S 23 39 || 1 Ch 11 41 is proof of his reputation as a soldier, and the name is found also in 2 S 12 9.10.15; 1 K 15 5; Mt 1 6. On the occurrence in Mt see esp. Heffern, *JBL*, XXXI, 69 ff (1912).

(2) A priest under Ahaz, who carried into effect

the latter's commands to introduce an Assyrian altar into the Temple and to use it for the sacrifices (2 K 16 10-16; see ALTAR). The same Uriah appears in Isa 8 2 as one of the two "faithful witnesses" taken by Isaiah in the matter of Maher-shalal-hash-baz. This description has seemed to many to conflict with Uriah's complacency in obeying Ahaz, but it must be remembered that (a) "faithful witness" means simply "one whom the people will believe," and (b) the articles in the sanctuary were not held as immutably sacred in the time of Ahaz as they were in later days. The omission of Uriah's name from the list in 1 Ch 6 10-14 is probably without significance, as Ch records only nine names from Solomon to the exile, showing that there must be many omissions. The corresponding list in Jos, Ant, X, viii, 6, contains 18 names, including Uriah's.

(3) A son of Shemaiah, of Kiriath-jearim, and a contemporary of Jeremiah. He was a prophet, and his prophecy agreed with Jeremiah's in all regards. Jehoiakim, roused to anger, arrested him, even at the trouble of a pursuit into Egypt, put him to death and desecrated his body (Jer 26 20-23). The story is told partly in order to show the greatness of Jeremiah's dangers, partly to bear record of the goodness of ANKAM (q.v.), Jeremiah's protector.

(4) A priest, the father of MEREMOTH (q.v.) (Ezr 8 33; Neh 3 4.21; 1 Esd 8 62 ["Urias," AV "Iri"]).

(5) One of those on Ezra's right hand at the reading of the Law (Neh 8 4; 1 Esd 9 43 ["Urias"]). Quite possibly identical with (4) above.

BURTON SCOTT EASTON

URIAS, ū-ri'as (Οὐρίας, *Oureias*; B<sup>b</sup>, Οὐρία, *Ouria*, A, Οὐρί, *Ouri*; AV Iri):

(1) The father of Marmoth (1 Esd 8 62) = "Uriah" of Ezr 8 33, and perhaps identical with (2).

(2) B<sup>b</sup> A, *Oureias*, *Ourias* = one of those who stood on Ezra's right hand as he read the Law (1 Esd 9 43) = "Uriah" of Neh 8 4.

URIAS (Οὐρίας, *Ourias*): AV; Gr form of "Uriah" (thus RV). The husband of Bath-sheba (Mt 1 6).

URIEL, ū-ri-el (אֱרִיֵּל, *'ari'el*, "flame of El [God]," or "El is my light"):

(1) A Kohathite, said in 1 Ch 15 5 to be the chief of the sons of Kohath (1 Ch 6 24 [Heb ver 9]; 15 5.11). He corresponds to Zephaniah in the pedigree of Heman in 1 Ch 6 33-38 (Heb 18-23). See Curtis, *Chron.*, 130 f.

(2) A man of Gibeah, and father of Micaiah the mother of King Abijah of Judah (2 Ch 13 2).

(3) The archangel (En 20 2, etc.). See next article.

URIEL (Οὐριήλ, *Ouriēl*, "fire or flame of God" or "my light is God"): Called only in 2 Esd 4 36 where RV and AV rightly give "Jeremiel the archangel" for AV "Uriel the archangel," but elsewhere known as one of the four chief archangels. He was the angel who instructed Ezra (2 Esd 4 1; 5 20; 10 28). In En 20 2 Uriel is the angel who is "over the world and Tartarus" (ὁ ἐπὶ τοῦ κόσμου καὶ τοῦ τάρταρου, ἡ ἐπὶ τοῦ κόσμου καὶ τοῦ τάρταρου), and as such is the conductor to Enoch in the world below, the secrets of which he explains. Cf also (Gr) 19 1; 21 5. In the (Lat) "Life of Adam and Eve," 48 (ed W. Meyer in *Abhand. d. Bayer. Akad. der Wiss.*, XIV, 1878, 250), Uriel (Oriel) accompanied Michael when at God's bidding he wrapped the bodies of Adam and Abel in three linen sheets and buried them in Paradise. In the lost "Prayer of Joseph" Uriel is the angel who wrestles and converses with Jacob

and knows the secrets of heaven (as in En those of Tartarus), but stands only 8th in rank, whereas in (Gr) En 20 2 ff he is the 1st of the six (or seven) archangels. In Sib Or 2 229 he is intrusted with the judgment of the Titans. Cf Milton, *Paradise Lost*, III, 690, "regent of the sun, and held the sharpest sighted Spirit of all in heaven."

(2) "Uriel" AV = RV and AVm "Jeremiel."

S. ANGUS

URIJAH. See URIAH, URIJAH.

URIM AND THUMMIM, ū'rim and thum'im (אֲרִיִּים וְתֻמִּיִּים, *hā-'urim w'ha-tummim* [art. omitted in Ezr 2 63; Neh 7 65],

perhaps "light and perfection," as intensive plurals): Articles not specifically described, placed in (next to, or on

[Heb 'el; LXX *epi*; Sam-Heb 'al]) the high priest's breastplate, called the "breast-plate of decision" (EV "judgment") (Ex 28 30; Lev 8 8). Their possession was one of the greatest distinctions conferred upon the priestly family (Dt 33 8; Ecclus 45 10), and seems to have been connected with the function of the priests as the mouthpiece of Jeh, as well as with the ceremonial side of the service (Ex 28 30; cf Arab. *kahin*, "soothsayer").

Through their use, the nature of which is a matter of conjecture, the Divine will was sought in national crises, and apparently the future fore-

2. Use in told, guilt or innocence established, the OT and, according to one theory, land divided (*Bābhā' Bathrā' 122a; Šanḥ.*

16a). Thus, Joshua was to stand before Eleazar who was to inquire for him after the judgment (decision) of the Urim (Nu 27 21). It seems that this means was employed by Joshua in the matter of Achan (Josh 7 14.18) and overlooked in the matter of the Gibeonites (9 14). Though not specifically mentioned, the same means is in all probability referred to in the accounts of the Israelites consulting Jeh after the death of Joshua in their warfare (Jgs 1 1.2; 20 18.26-28). The Danites in their migration ask counsel of a priest, perhaps in a similar manner (Jgs 18 5.7). It is not impossible that even the prophet Samuel was assisted by the Urim in the selection of a king (1 S 10 20-22). During Saul's war with the Philis, he made inquiry of God with the aid of the priest (1 S 14 36.37), Ahijah, the son of Abitub, who at that time wore the ephod (1 S 14 3). Although on two important occasions Jeh refused to answer Saul through the Urim (1 S 14 37; 28 6), it appears (from the LXX version of 1 S 14 41; see below) that he used the Urim and Thummim successfully in ascertaining the cause of the Divine displeasure. The accusation of Doeg and the answer of the high priest (1 S 22 10.13.15) suggest that David began to inquire of Jeh through the priesthood, even while he was an officer of Saul. After the massacre of the priests in Nob, Abiathar fled to the camp of David (ver 20), taking with him the ephod (including apparently the Urim and Thummim, 23 6) which David used frequently during his wanderings (23 2-4.9-12; 30 7.8), and also after the death of Saul (2 S 2 1; 5 19.23; 21 1). After the days of David, prophecy was in the ascendancy, and, accordingly, we find no clear record of the use of the Urim and Thummim in the days of the later kings (cf, however, Hos 3 4; Ecclus 33 3). Still, in post-exilic times we find the difficult question of the ancestral right of certain priests to eat of the most holy things reserved till there would stand up a priest with Urim and with Thummim (Ezr 2 63; Neh 7 65; 1 Esd 5 40; *Šōtāh 48b*).

Though Jos sets the date for the obsolescence of the Urim and Thummim at 200 years before his time, in the days of John Hyrcanus (*Ant*, III,

viii, 9), the Talm reckons the Urim and Thummim among the things lacking in the second Temple (*Šōtāh* 9 10; *Yōmā'* 21b; *Yeru Kid* 65b). Both Jos and the Talm identify (Tradition- a) Views the Urim and Thummim with the stones of the breastplate. The former simply states that the stones shone whenever the *sh'khināh* was present at a sacrifice or when the army proceeded to battle.

"God declared beforehand by those twelve stones which the high priest bare on his breast, and which were inserted into his breastplate, when they should be victorious in battle; for so great a splendor shone forth from them before the army began to march, that all the people were sensible of God's being present for their assistance" (*Ant.*, III, viii, 9).

The Talmudic explanation suggests that by the illumination of certain letters the Divine will was revealed, and that in order to have a complete alphabet, in addition to the names of the tribes, the breastplate bore the names of the patriarchs, Abraham, Isaac and Jacob, and the words *shibhāz y'shūrun*. A later scholar even suggests that the letters moved from their places to form words (*Yōmā'* 73a,b). Characteristically enough the Talm prescribes rules and suggestions for the consultation of the non-existing Urim and Thummim: that the one asking must be a man of public importance, that the question must pertain to the public weal; that the priest must face the *sh'khināh* (west); that one question be asked at a time, and so forth (ib).

It is difficult to tell just how much, if anything, of a lingering tradition is reflected in the view that the Urim and Thummim and stones of the breastplate were identical. In the absence of other ancient clues, however, it is not safe to reject even the guesses of the Jews of the second temple in favor of our own. We do not even know the meaning of the word *hōshen*, so confidently tr<sup>d</sup> "pouch" or "receptacle" by opponents of the older view, without any basis whatever. On the other hand the theory of identification was widespread. Even Philo leans toward it in his *De Monarchia*, although in his *Vita Mosis* (iii) he seems to have in mind two small symbols representing Light and Truth embroidered on the cloth of the *hōshen* or hung round the neck of the high priest, similar to the Egypt symbol of justice. Another very old view is that the Urim and Thummim consisted of a writing containing the Ineffable Name (Pseudo-Jonathan on Ex 28 20; cf Rashi and Nachmanides ad loc.).

The view most generally held today is that the Urim and Thummim were two sacred lots, one indicating an affirmative or favorable answer, the other a negative or unfavorable answer (Michaelis, Ewald, Critical Views Wellhausen, Robertson Smith, Driver, G. F. Moore, Kennedy, Muss-Arnolt).

The chief support of this view is found, not in the MT, but in the reconstruction by Wellhausen and Driver of 1 S 14 41 ff on the basis of LXX: "If this fault be in me or in Jonathan, my son, give Urim [*dōs dēlous*], and if it be in thy people Israel, give Thummim [*dōs hosiōtēta*]." The following sentence clearly suggests the casting of lots, possibly lots on which the names of Saul and Jonathan were written, and "Jonathan" was taken. Efforts have been made to support the view that the Urim and Thummim themselves were sacred lots on the basis of analogous customs among other peoples (e.g. pre-Islamic Arabs [Moore in *EB*] and Babylonians [W. Muss-Arnolt in *Jew Enc* and *AJSL*, July, 1900]). It must be borne in mind, however, that whatever the lot-theory has to recommend it, it is inconsistent not only with the post-Bib. traditions, but also with the Bib. data. For those who are not inclined to give much weight to the passages connecting the Urim and Thummim with the high priest's apparel (Ex 28 30; Lev 8 8, both "P"), there is of course no difficulty in dissociating the two, in spite of the fact that for the use of this

system of divination the one thing necessary in the historical passages on which they rely seems to be the ephod. Still, if we are to think of two lots, one called and possibly marked "Urim" and the other "Thummim," it is difficult to get any meaning from the statement (1 S 14 37; 28 6) that Jeh did not answer Saul on certain occasions, unless indeed we surmise for the occasion the existence of a third nameless blank lot. A more serious difficulty arises from the fact that the answers ascribed to the Urim and Thummim are not always the equivalent of "yes" or "no" (cf Jgs 1 2; 20 18; 1 S 22 10; 2 S 5 23; 21 1), even if we omit from consideration the instances where an individual is apparently pointed out from all Israel (cf the instances of the detection of Achan and the selection of Saul with that of Jonathan, above).

If we turn to etymology for assistance, we are not only on uncertain ground, but when Bab and other foreign words are brought in to bolster up a theory about anything so little understood as the Urim and Thummim, we are on dangerous ground. Thus

Muss-Arnolt is ready with Bab words (*urtu*, "command," and *tamītu*, "oracular decision"); others suggest *tmē*, the Egypt image of justice; still others connect Urim with *ārar*, "to curse," in order to make it an antonym of *tummim*, "faultlessness." It is generally admitted, however, that, as pointed in the MT, the words mean "light" and "perfection," on the basis of which the Talm (*Yōmā'* 73b) as well as most of the Gr VSS tr<sup>d</sup> them (*dēlōsis kai alētheia*; *phōtismōt kai teleiōtētes*), although Symmachus in one place (Dt 33 8), who is followed by the Vulg, connects Urim with the word *Tōrah* and understands it to mean "doctrine" (*teleiōtēs kai didachē*). Though loth to add to the already overburdened list of conjectures about these words, it appears to the present writer that if Urim and Thummim are antonyms, and Urim means "light," it is by no means difficult to connect Thummim with darkness, inasmuch as there is a host of Heb stems based on the root *-tm*, all indicating concealing, closing up, and even darkness (cf אָטַם, אָטַם, אָטַם, אָטַם, אָטַם, אָטַם [see Job 40 13], אָטַם and even אָטַם and cognate Arab. words in *BDB*). This explanation would make Urim and Thummim mean "illuminated" and "dark" (cf Gaster in Hastings, *ERE*, IV, 813), and, while fitting well with the ancient theories or traditions, would not be excluded by the recent theory of lots of opposite purport.

NATHAN ISAACS

**USURY**, ū'zhū-ri: The Heb law concerning exaction of interest upon loans was very humane.

Hebrews were to lend to their brethren 1. In the without interest (Ex 22 25; Lev 25 OT 36 f; Dt 23 19 f). This, however, did not apply to a stranger (Dt 23 20).

Two stems are used in the OT, rendered in AV "usury," in RV better rendered "interest": (1) vb. נָשָׂה, *nāshāh* (Ex 22 25; Isa 24 2; Jer 15 10), and the noun form, מַשְׁשָׂה, *mashshā'* (Neh 5 7.10); (2) a stronger and more picturesque word, נָשַׁח, *nāshakh*, "to bite," "to vex," and so "to lend on interest" (Dt 23 19.20); noun form נֶשֶׁח, *neshekh* (Ex 22 25; Lev 25 36 f; Ps 15 5; Prov 28 8; Ezk 18 8.13.17; 22 12). It would be easy to go from a fair rate of interest to an unfair rate, as seen in the history of the word "usury," which has come to mean an exorbitant or unlawful interest. Abuses arose during the exile. Nehemiah forced the people after the return to give back exactions of "one hundredth," or 1 per cent monthly which they took from their brethren (Neh 5 10f; cf Ezk 22 12). A good citizen of Zion is one who put not out his

money to usury (Ps 15 5). One who is guilty of this comes to disaster (Prov 28 8).

The Gr word is *roskos, lokos*, lit. "offspring," interest springing out of the principal. Money lenders were numerous among the Jews in Christ's day, and, in the parable of the Talents, He represents the lord of the unprofitable servant as rebuking the sloth in the words, "I should have received mine own with interest" (Mt 25 27; Lk 19 23 RV).

EDWARD BAGBY POLLARD

**UTA**, ū'ta (Oúrá, *Outá*): "The sons of Uta" returned with Zerubbabel (1 Esd 5 30); wanting in the || Ezr 2 45; Neh 7 48.

**UTHAI**, ū'-thí, ū'thā-ī (וּתַי, *'ūthay*, meaning uncertain):

(1) A descendant of Judah, of the clan of Perez (1 Ch 9 4) = "Athaiah" of Neh 11 4.

(2) Son of Bigvai (Ezr 8 14); called "Uthi" in 1 Esd 8 40.

**UTHI**, ū'thí (A, Oúthí, *Outhí*, B, Oúróú, *Outoú*): One of the sons of Bago (Bigvai) who returned at the head of his family with Ezra (1 Esd 8 40) = "Uthai" of Ezr 8 14.

**UTMOST**, ut'mōst, **UTTERMOST**, ut'ēr-mōst, SEA. See MEDITERRANEAN SEA.

**UTTERMOST**, ut'ēr-mōst: A pleonastic compound of a comparative ("utter"; cf "outer") and a superlative ("most"), in AV used interchangeably with the ordinary superlative forms "utmost" (cf Mt 12 42; Lk 11 31) and "outmost" (cf Ex 26 4.10). RV adds still another form, "outermost," in 2 K 7 5.8 (AV "uttermost"). RV has made a few changes to secure a more accurate tr (Jer 9 26; Joel 2 20, etc) or to give uniformity (Ex 26 4; Mt 5 26; 12 42, etc), but for the most part has left AV undisturbed.

**UZ**, uz (עֶזְרָא, *'ēzēz*; עֶזְרָא, *'erez*; *'ūz*; Ως, *Ōs*, Ως, *Ōz*, Αὐσίτις, *Ausitis*):

(1) In Gen 10 23 Uz is the eldest son of Aram and grandson of Shem, while in 1 Ch 1 17 Uz is the son of Shem. LXX inserts a

**Biblical Data** passage which supplies this lacking name. As the tables of the nations in Gen 10 are chiefly geographical and ethnographical, Uz seems to have been the name of a district or nation colonized by or descended from Semites of the Aramaean tribe or family.

(2) The son of Nahor by Milcah, and elder brother of Buz (Gen 2 21). Here the name is doubtless personal and refers to an individual who was head of a clan or tribe kindred to that of Abraham.

(3) A son of Dishan, son of Seir the Horite (Gen 36 28), and personal name of a Horite or perhaps of mixed Horite and Aramaean blood.

(4) The native land and home of Job (Job 1 1), and so situated as to be in more or less proximity to the tribe of the Temanites (2 11), the Shuhites (2 11), the Naamathites (2 11), the Buzites (32 2), and open to the inroads of the Chaldaeans (1 17), and the Sabaean (1 15RV), as well as exposed to the great Arabian Desert (1 19). See next article.

(5) A kingdom of some importance somewhere in Southern Syria and not far from Judaea, having a number of kings (Jer 25 20).

(6) A kingdom, doubtless the same as that of Jer 25 20 and inhabited by or in subjection to the Edomites (Lam 4 21), and hence not far from Edom.

JAMES JOSIAH REEVE

**UZ** (עֶזְרָא, *'ūz*; LXX Αὐσίτις, *Ausitis*; Vulg *Ausitis*): The home of the patriarch Job (Job 1 1; Jer 25 20, "all the kings of the land of Uz"; Lam 4 21, "daughter of Edom, that dwellest in the land of Uz"). The land of Uz was, no doubt, the pasturing-ground inhabited by one of the tribes of that name, if indeed there be more than one tribe intended. The following are the determining data occurring in the Book of Job. The country was subject to raids by Chaldaeans and Sabaeans (1 15.17); Job's three friends were a Temanite, a Naamathite and a Shuhite (2 11); Elihu was a Buzite (32 2); and Job himself is called one of the children of the East (*Kedhem*). The Chaldaeans (*kasdim*, descendants of Chesed, son of Nahor, Gen 22 22) inhabited Mesopotamia; a branch of the Sabaeans also appears to have taken up its abode in Northern Arabia (see SHEBA). Teman (Gen 36 11) is often synonymous with Edom. The meaning of the designation Naamathite is unknown, but Shuah was a son of Keturah the wife of Abraham (Gen 25 2), and so connected with Nahor. Shuah is identified with Suhu, mentioned by Tiglath-pileser I as lying one day's journey from Carchemish; and a "land of Uzza" is named by Shalmaneser II as being in the same neighborhood. Buz is a brother of Uz ("Huz," Gen 22 21) and son of Nahor. Esar-haddon, in an expedition toward the W., passed through Bazu and Hazu, no doubt the same tribes. Abraham sent his children, other than Isaac (so including Shuah), "eastward to the land of *Kedhem*" (Gen 25 6). These factors point to the land of Uz as lying somewhere to the N.E. of Pal. Tradition supports such a site. Jos says "Uz founded Trachonitis and Damascus" (*Ant*, I, vi, 4). Arabian tradition places the scene of Job's sufferings in the Hauran at *Deir Eiyūb* (Job's monastery) near Nawā. There is a spring there, which he made to flow by striking the rock with his foot (*Korān* 38 41), and his tomb. The passage in the *Korān* is, however, also made to refer to Job's Well (cf JERUSALEM).

**LITERATURE**.—*Talm of Jerus* (Fr. tr by M. Schwab, VII. 289) contains a discussion of the date of Job; Le Strange, *Pal under the Moslems*, 220-23, 427, 515.

THOMAS HUNTER WEIR

**UZAI**, ū'zī, ū'zā-ī (וּזַי, *'ūzay*, meaning unknown): Father of Palal (Neh 3 25).

**UZAL**, ū'zal (וּזַל, *'ūzāl*): Sixth son of Joktan (Gen 10 27; 1 Ch 1 21). Uzal as the name of a place perhaps occurs in Ezk 27 19. RV reads, "Vedan and Javan traded with yarn for thy wares." Here an obscure verbal form, *m'ūzāl*, is taken to mean "something spun," "yarn." But with a very slight change we may read *m'ūzāl* = "from Uzal."

The name is identical with the Arab. *'Auzāl*, the old capital of Yemen, later called *San'ā'*. *San'ā'* is described as standing high above sea-level in a fertile land, and traversed by a river bed which in the rainy season becomes a torrent. Under the Himyarite dynasty it succeeded *Zafār* as the residence of the Tubba's. If it is the same place as the Audzara or Ausara of the classics, it is clear why Arab. geographers dwell upon its great antiquity. The most celebrated feature of the town was Ghumdān, an immense palace, the building of which tradition ascribes to Shorāhbil, the 6th known king of the Himyarites. According to Ibn Khaldoun this building had four fronts in color red, white, yellow and green respectively. In the midst rose a tower of seven stories, the topmost being entirely of marble (Caussin de Perceval, *Essai*, II, 75). In the 7th cent. AD the town became the capital of the Zaidite Imams, and the palace was destroyed toward the middle of that century by order of the caliph Othman.

A. S. FULTON

**UZZA**, uz'a, **UZZAH**, uz'a (וֶזְאָה, 'uzzāh [2 S 6 6-8], otherwise וֶזְאָה, 'uzzā', meaning uncertain):

(1) One of those who accompanied the ark on its journey from Kiriath-jearim toward David's citadel (2 S 6 3-8, "Uzzah" = 1 Ch 13 7-11, "Uzza"). From the text of 2 S 6 3-8, as generally corrected with the help of LXX, it is supposed that Uzzah walked by the side of the ark while Ahio (or "his brother") went in front of it. The word which describes what happened to the oxen is variously trd; RV has "stumbled"; others render it, "They let the oxen slip," "The oxen shook [the ark]." Uzzah, whatever it be that took place, caught hold of the ark; something else happened, and Uzzah died on the spot. If the word trd "rashness" (RVm) in ver 7 (not "error" as EV) is to be kept in the text, Uzzah would be considered guilty of too little reverence for the ark; but the words "for [his] rashness" are wanting in LXX B, while 1 Ch 13 10 has "because he put forth his hand to the ark," and further no such Heb word as we find here is known to us. The older commentators regarded the death as provoked by non-observance of the provisions about the ark as given in the Pent, but it is generally believed today that these were not known in David's time.

What is clear is that Uzzah's act led to an accident of some kind, and the event was regarded by David as inauspicious, so that the journey with the ark was discontinued. We know how the OT writers represent events as due to Divine intervention where we would perhaps discern natural causes.

(2) The garden of Uzza (2 K 21 18.26). Manasseh the king is said (ver 18) to have been "buried in the garden of his own house, in the garden of Uzza"; and Amon (ver 26) "was buried in his sepulchre in the garden of Uzza." It has been suggested that "Uzza" = "Uzziah" (וֶזְאָה, 'uzziyāh) = "Azariah" (cf 2 K 15 1-6). The garden of Manasseh would then be identical with that of Uzziah, by whom it was originally laid out. 2 Ch 33 20 does not mention the garden.

(3) Son of Shimei, a Merarite (1 Ch 6 29 [Heb 14]), RV "Uzzah," AV "Uzza."

(4) A descendant of Ehud, and head of a Benjamite family (1 Ch 8 7, "Uzza"). Hogg, *JQR*, 102 ff (1893) (see Curtis, *Chron.*, 156-59), finds a proper name "Iglam" in ver 6, and so reads "and Iglam begat Uzza and Ahishahar."

(5) Head of a Nethinim family that returned from Babylon (Ezr 2 49) = "Uzza" of Neh 7 51.

DAVID FRANCIS ROBERTS

**UZZEN-SHEERAH**, uz'en-shē'ē-ra (וֶזְזֵן שְׁעֵרָה, 'uzzēn she'ērāh; LXX, instead of a place-name, reads καὶ υἱοὶ Ὀζάν Σειρά, καὶ υἱοὶ Ὀζάν, Σεῖρα, "and the sons of Ozan, Sheera"; AV Uzzen-sheerah, u.-she'ra): As it stands in MT this is the name of a town built by Sheerah, daughter of Ephraim, to whom is attributed also the building of the two Beth-horons (1 Ch 7 24). No satisfactory identification has been proposed. LXX suggests that the text may have been tampered with.

**UZZI**, uz'i (וֶזִי, 'uzzi, perhaps "my strength"):

(1) A descendant of Aaron and high priest, unknown apart from these sources (1 Ch 6 5.6.51 [Heb 5 31.32; 6 36]; Ezr 7 4).

(2) An eponym of a family of Issachar (1 Ch 7 2.3).

(3) Head of a Benjamite family (1 Ch 7 7), or more probably of a Zebulunite family (see Curtis, *Chron.*, 145-49).

(4) Father of Elah, a Benjamite (1 Ch 9 8), perhaps the same as (5).

(5) A son of Bani and overseer of the Levites in Jerus (Neh 11 22).

(6) Head of the priestly family of Jedaiah (Neh 12 19.42).

DAVID FRANCIS ROBERTS

**UZZIA**, u-zī'a (וֶזְזִיָּה, 'uzziyā', "my strength is Jeh"; see UZZIAH): An Ashterathite and one of David's mighty men (1 Ch 11 44).

**UZZIAH**, u-zī'a, ōō-zī'a (AZARIAH) (וֶזְזִיָּה, 'uzziyāh [2 K 15 13.30; Hos 1 1; Am 1 1; Zec 14 5], וֶזְזִיָּהּ, 'uzziyāhū [2 K 15 32.34; Isa 1 1; 6 1; 7 1; 2 Ch 26 1ff; 27 2]; also called וֶזְזִיָּהּ, 'ūzaryāh [2 K 14 21; 15 1.7; 1 Ch 3 12], וֶזְזִיָּהּ, 'ūzaryāhū [2 K 15 6.8]; Ἀζαρίας, Azarias, in K, elsewhere Ὀζίας, Ozias; the significations of the names are similar, the former meaning "my strength is Jeh"; the latter, "Jeh has helped." It has been thought that the form "Uzziah" may have originated by corruption from the other. The history of the reign is given in 2 K 15 1-8 and 2 Ch 26):

Uzziah or Azariah, son of Amaziah, and 11th king of Judah, came to the throne at the age of 16.

The length of his reign is given as 52 years. The chronological questions raised by this statement are considered below. His accession may here be provisionally dated in 783 BC. His father Amaziah had met his death by popular violence (2 K 14 19), but Uzziah seems to have been the free and glad choice of the people (2 Ch 26 1).

The unpopularity of his father, owing to a great military disaster, must ever have been present to the mind of Uzziah, and early in his reign he undertook and successfully carried through an expedition against his father's enemies of 20 years before, only extending his operations over a wider area. The Edomites, Philis and Arabians were successively subdued (these being members of a confederacy which, in an earlier reign, had raided Jerus and nearly extirpated the royal family, 2 Ch 21 16; 22 1); the port of Eloth, at the head of the Red Sea, was restored to Judah, and the city rebuilt (2 K 14 22; 2 Ch 26 2); the walls of certain hostile towns, Gath, Jabneh and Ashdod, were razed to the ground, and the inhabitants of Gur-baal and Maan were reduced to subjection (2 Ch 26 6.7). Even the Ammonites, E. of the Jordan, paid tribute to Uzziah, and "his name spread abroad even to the entrance to Egypt; for he waxed exceeding strong" (ver 8).

Uzziah next turned his attention to securing the defences of his capital and country. The walls of Jerus were strengthened by towers

**3. Home Defences** built at the corner gate, at the valley gate, and at an angle in the wall (see plan of Jerus in the writer's *Second Temple in Jerus*); military stations were also formed in Philistia, and in the wilderness of the Negeb, and these were supplied with the necessary cisterns for rain storage (vs 6.10). The little realm had now an extension and prosperity to which it had been a stranger since the days of Solomon.

These successes came so rapidly that Uzziah had hardly passed his 40th year when a great personal calamity overtook him. In the earlier

**4. Uzziah's Leprosy and Retirement** part of his career Uzziah had enjoyed and profited by the counsels of Zechariah, a man "who had understanding in the vision of God" (2 Ch 26 5), and during the lifetime of this godly monitor "he set himself to seek God." Now it happened to him as with his grandfather Jehoshaphat, who, so long as his preserver Jehoiada lived, acted

admirably, but, when he died, behaved like an ingrate, and slew his son (2 K 12 2; 2 Ch 24 2, 22). So now that Zechariah was gone, Uzziah's heart was lifted up in pride, and he trespassed against Jeh. In the great kingdoms of the East, the kings had been in the habit of exercising priestly as well as royal functions. Elated with his prosperity, Uzziah determined to exercise what he may have thought was his royal prerogative in burning incense on the golden altar of the temple. Azariah the high priest, with 80 others, offered stout remonstrance; but the king was only wroth, and pressed forward with a censer in his hand, to offer the incense. Ere, however, he could scatter the incense on the coals, and while yet in anger, the white spots of leprosy showed themselves upon his forehead. Smitten in conscience, and thrust forth by the priests, he hastened away, and was a leper ever after (2 Ch 26 16-21).

Uzziah's public life was now ended. In his enforced privacy, he may still have occupied himself with his cattle and agricultural operations, "for he loved husbandry" (2 Ch 26 10); but his work in the government was over. Both K and Ch state in nearly identical words: "Jotham the king's son was over the household, judging the people of the land" (2 K 15 5; 2 Ch 26 21). Works of the same kind as those undertaken by Uzziah, viz. building military stations in the hills and forests of Judah, repairing the walls of city and temple, etc. are attributed to Jotham (2 Ch 27 3 ff); the truth being that Jotham continued and completed the enterprises his father had undertaken.

The chronology of the reign of Uzziah presents peculiar difficulties, some of which, probably, cannot be satisfactorily solved. Reckoning upward from the fall of Samaria in 721 BC, the Bib. data would suggest 759 as the first year of Jotham. If, as is now generally conceded, Jotham's regnal years are reckoned from the commencement of his reign, when his father had been stricken with leprosy, and if, as synchronisms seem to indicate, Uzziah was about 40 years of age at this time, we are brought for the year of Uzziah's accession to 783. His death, 52 years later, would occur in 731. (On the other hand, it is known that Isaiah, whose call was in the year of Uzziah's death, Isa 6 1, was already exercising his ministry in the reign of Jotham, Isa 1 1.) Another note of time is furnished by the statement, that the earliest utterance of Amos the prophet was "two years before

the earthquake" (Am 1 1). This earthquake, we are told by Zechariah, was "in the days of Uzziah, king of Judah" (Zec 14 5). Jos likewise embodies a tradition that the earthquake occurred at the moment of the king's entry into the temple (*Ant.* IX, x, 4). Indubitably the name of Uzziah was associated in the popular mind with this earthquake. If the prophecy of Amos was uttered a year or two before Jeroboam's death, and this is placed in 759 BC, we are brought near to the date already given for Uzziah's leprosy (Jeroboam's date is put lower by others).

In 2 K 15 Uzziah is referred to as giving data for the accessions of the northern kings (ver 8, Zechariah; ver 13, Shallum; ver 17, Menahem; ver 23, Pekahiah; ver 27, Pekah), but it is difficult to fit these synchronisms into any scheme of chronology, if taken as regnal years. Uzziah is mentioned as the father of Jotham in 2 K 15 32,34; 2 Ch 27 2, and as the grandfather of Ahaz in Isa 7 1. He was living when Isaiah began his ministry (Isa 1 1; 6 1); when Hosea prophesied (Hos 1 1); and is the king in whose reign the afore-mentioned earthquake took place (Zec 14 5). His name occurs in the royal genealogies in 1 Ch 3 11 and Mt 1 8,9. The place of his entombment, owing to his having been a leper, was not in the sepulchers of the kings, but "in the garden of Uzza" (2 K 21 26; cf 2 Ch 26 23). Isaiah is stated to have written a life of Uzziah (2 Ch 26 22). W. SHAW CALDECOTT

**UZZIEL**, u-zī'el, uz'i-el, ōō'zi-el (זְזִיֵּל, 'uzzī'ēl, "El [God] is my strength"):

(1) A "son" of Kohath (Ex 6 18,22; Lev 10 4; Nu 3 19,30; 1 Ch 6 2,18 [Heb 5 28; 6 3]; 15 10; 23 12,20; 24 24), called in Lev 10 4 "uncle of Aaron." The family is called Uzzielites (זְזִיֵּלִים, *hā'uzzī'ēlī* [coll.]) in Nu 3 27; 1 Ch 26 23.

(2) A Simeonite captain (1 Ch 4 42).

(3) Head of a Benjamite (or according to Curtis a Zebulunite) family (1 Ch 7 7).

(4) A Hemanite musician (1 Ch 25 4); LXX B has Ἀζαρέλ, *Azaraēl* = "Azarel," the name given in ver 18. See AZAREL.

(5) A Levite "son" of Jeduthun (2 Ch 29 14).

(6) A goldsmith who joined in repairing the wall of Jerus (Neh 3 8).

(7) The reading of LXX (Ὀζιήλ, *Oziēl*) for Jahaziel in 1 Ch 23 19. See JAHAZIEL, (3).

DAVID FRANCIS ROBERTS

V

**VAGABOND**, vag'a-bond (בָּדָד, *nādh*, "to wander"): The word is used in the curse pronounced on Cain (Gen 4 12,14). RV substitutes in each case "wanderer," but in Ps 109 10 it retains "vagabonds." "Vagabond Jews" (περιέρχουσαι, *periérchomai*; RV "strolling Jews") were persons who traveled about as professional exorcists (Acts 19 13).

**VAHEB**, vā'heb (וָהֶב, *wāhēbh*; זָוֶב, *Zōvb*): The name occurs in a quotation from the book of the Wars of Jeh in Nu 21 14. See SUPHAH. It was apparently in Amorite territory. It is not identified.

**VAIL**, vāl. See VEIL.

**VAIN**, vān: The adj. of "vanity," and representing the same Heb and Gr words as does the latter, with a few additions (chiefly *kenós*, *kenós*, "empty," and its compounds in the NT). And "vain" can always be replaced by its synonym "empty," often with advantage in modern Eng. (Job 15 2; 1 Cor 15 14, etc). The exception is the phrase "in vain," and even there the interchange can be made if some (understood) noun such as "ways" be added. So

"to take God's name in vain" (Ex 20 7; Dt 5 11) means simply to take it for an "empty" ("not good") purpose.

**VAINGLORY**, vān-glō'ri (κενοδοξία, *kenodoxia*): "Vainglory" is the tr of *kenodoxia*, "empty glory" or "pride," nearly akin to vanity in the modern sense (Phil 2 3). *Kenodoxos* is "vainglorious" (Gal 5 26, "Let us not be desirous of vainglory," RV "Let us not become vainglorious"). In 1 Jn 2 16 RV has "the vainglory of life" (*alazoneia tou biou*) for "the pride of life"; cf Jas 4 16, "Ye glory in your vauntings" (*alazoneia*). *Kenodoxia* is tr<sup>d</sup> "vainglory" (Wisd 14 14, "For by the vain glory of men they [idols] entered into the world," RV "vaingloriousness"); *alazoneia* occurs in Wisd 5 8, tr<sup>d</sup> "vaunting." "Pride is applicable to every object, good or bad, high or low, small or great; vanity is applicable only to small objects; pride is therefore good or bad; vanity is always bad; it is always emptiness or nothingness" (Crabb, *English Synonyms*).

W. L. WALKER

**VAIZATHA**, vī'za-tha, va-iz'a-tha, **VAJEZATHA**, va-jez'a-tha, vaj-ē-zā'tha (וַיְזָתָה, *vayzāthā*): One



of the sons of Haman (Est 9 9). The form has been held to be corrupt, the 1 (w) being exceptionally long, and the 7 (z) exceptionally short (Benfey, *Die persischen Keilinschriften* [1847], XVIII, 93), and points to *Vahyazdāta*, "Given of the Best-One" (OHL, 255).

**VALE, vāl, VALLEY, val'i:**

(1) נָאֵי, *gay*; either absolute: "from Bamoth to the valley that is in the field of Moab" (Nu 21 20); or with a proper name: "valley of Hinnom," also "valley of the son of Hinnom" (Josh 15 8); "valley of Slaughter" (Jer 7 32); "valley of Zeboim" (1 S 13 18); "valley of Zephathah" (2 Ch 14 10); "valley of Hamon-gog" (Ezk 39 11); "valley of Iphtah-el" (Josh 19 14); "valley of the mountains" (Zec 14 5); "Valley of Salt" (2 S 8 13); "valley of vision" (Isa 22 1); once (in RV) as a place-name: "until thou comest to Gai" (AV "the valley") (1 S 17 52); also (RV) "Ge-harashim" (1 Ch 4 14); cf "valley of craftsmen" (m "Ge-haharashim") (Neh 11 35).

(2) עֵמֶק, *'emek*, √ עָמַק, *'amök*, "to be deep"; cf Arab. عَمَق, *'amuk*, "to be deep"; عَمِيق, *'umk*, "depth"; عَمِيْق, *'Ammik*, a village in the valley of Coele-Syria; absolute: "He could not drive out the inhabitants of the valley" (Jgs 1 19); often with place-names: "valley of Achor" (Josh 7 24); "valley of Aijalon" (Josh 10 12); "valley of Gibeon" (Isa 23 21); "vale of Hebron" (Gen 37 14); "valley of Jehoshaphat" (Joel 3 2); "vale of Rephaim," AV "valley of the giants" (Josh 15 8); "vale of Shaveh" (Gen 14 17); "vale of Siddim" (Gen 14 3); "valley of Succoth (Ps 60 6); cf "valley of Weeping" (AV "Baca") (Ps 84 6); "valley of Beracah" (m "Blessing") (2 Ch 20 26); "valley of decision" (Joel 3 14); "vale of Elah" (m "terebinth") (1 S 17 2); "the King's Vale" (Gen 14 17); but "the king's dale" (2 S 18 18); "Emek-keziz," AV "valley of Keziz" (Josh 18 21).

(3) בִּקְעָה, *bik'äh*, √ בָּקַע, *bäka*, "to cleave," hence "valley," esp. "broad valley" or "plain"; cf Arab. بَقْعَة, *bak'at*, "wet meadow," بَقَاع, *Bik'at*, Coele-Syria; absolute: "a land of hills and valleys" (Dt 11 11); with place-names: "valley of Jericho" (Dt 34 3); "valley of Lebanon" (Josh 11 17); "valley of Megiddo" (2 Ch 35 22); "valley of Mizpah" (Josh 11 8).

(4) נַחַל, *nahal*, also "river" or "stream"; absolute: "Isaac's servants digged in the valley" (Gen 26 19); with place-names: "valley [AV "river"] of the Arnon" (Dt 2 24); "valley of Eshcol" (Nu 32 9); "valley of Gerar" (Gen 26 17); "valley of Shittim" (Joel 3 18); "valley of Sorek" (Jgs 16 4); "valley of Zered" (Nu 21 12).

(5) שְׁפֵלָה, *sh'phäläh*, √ שָׁפַל, *shāphäl*, "to be low"; cf Arab. سَفَل, *safal*, "to be low"; AV "valley" or "vale," RV "lowland," the coast and foothills of Western Pal.

(6) ἀλάω, *alāōn*, "valley" (Jth 4 4; 7 3; 10 10).  
(7) φάραγξ, *phāragx*: "Every valley shall be filled" (Lk 3 5).

The valley gate (Neh 2 13, etc) may have had about the location of the present Jaffa gate, if by "valley" is meant the valley of Hinnom. If the Tyropæon is meant, it would have been near the southwestern corner of the *hārām* area. See JERUSALEM.

The valleys of the mountainous part of Pal are mostly dry, rocky wadies with occasional torrents in the winter season. Those which descend to the W. widen out as they approach the plain and contain broad fields and meadows which in the winter and

spring at least are fresh and green. The valley of the Jordan, the valley of Megiddo and the valley of Lebanon (i.e. Coele-Syria) contain much cultivable land: "the herds that were in the valleys" (1 Ch 27 29): "They of Beth-shemesh were reaping their wheat harvest in the valley" (1 S 6 13); "The valleys also are covered over with grain" (Ps 65 13). See BROOK; CHAMPAIGN; LOWLAND; RIVER; SHEPHELAH. ALFRED ELY DAY

**VALIANT, val'yant, VALIANTLY, val'yant-li** (חַיִל, *hayil*; ἰσχυρός, *ischurós*): "Valiant" in the OT is for the most part the tr of *hayil*, "power," or "might," and is applied to the courageous and to men of war ("mighty men of valor"), as in 1 S 14 52; 31 12; 2 S 11 16, etc; in some passages *ben hayil*, "a son of might" (Jgs 21 10; 1 S 18 17; 2 S 2 7, etc). A few other Heb words (*gibbōr*, etc) are thus rendered. In the NT the word occurs once in AV (He 11 34, "valiant in fight"; RV "mighty in war"). "Valiantly" is the tr of the same Heb word (Nu 24 18; Ps 60 12, etc); in one case in AV of *hāzak* (1 Ch 19 13, ARV "play the man," ERV "men"). In some instances RV has variations, as "man of valor" for "valiant man" (1 S 16 18), "valiant" for "strong" (1 Ch 26 7.9; Jer 48 14, etc). W. L. WALKER

**VALLEY, val'i.** See VALE, VALLEY.

**VALLEY GATE** (שַׁעַר הַגַּי, *sha'ar ha-gay*), "Gate of the Gai": Is placed (Neh 3 13) between the "tower of the furnaces" and the "dung gate"; from here Nehemiah (2 13) set out on his ride down the "Gai" (Hinnom) to Siloam, and, too (12 31.38), from here the Levites commenced their compass of the city in two directions. It must have been an ancient gate, for Uzziah added towers to it (2 Ch 26 9). It was probably near the S.W. corner of the city and near to, if not identical with, the gate found by Bliss near (now in) the Protestant Cemetery. See JERUSALEM, VI, 13.

E. W. G. MASTERMAN  
**VALLEY, JORDAN.** See JORDAN VALLEY.

**VALLEY OF DECISION** (עֵמֶק הַחֵרֶץ, *'emek he-hārūç*). See JEHOSEPHAT, VALLEY OF.

**VALLEY OF GIANTS.** See REPHAIM, VALE OF.

**VALLEY OF KEZIZ.** See EMEK-KEZIZ.

**VALLEY OF SLAUGHTER.** See HINNOM; SLAUGHTER, VALLEY OF; TOPHETH.

**VALLEY OF VISION** (גֵּרַם הַחִזְיוֹן, *gē' hizziyōn*): A symbolic name generally understood to signify Jerus as being the home of prophetic vision (Isa 22 1.5).

**VAMPIRE, vam'pīr** (עֲלֻקָּה, *'alūkāh*): RVm for "horseleach" (Prov 30 15) has "vampire." See HORSELEACH.

**VANIAH, va-ni'a** (וַנְיָהּ, *wanyāh*, meaning unknown): A son of Bani, who had married a foreign wife (Ezr 10 36). The text is, however, doubtful. LXX B has Οὐνεχῶ, *Ouiechōā*, Σ, Οὐνερεχῶ, *Ouierēchō*, A, Οὐουριά, *Ououniā*, Luc., Οὐανιά, *Ouaniā*.

**VANITY, van'i-ti, VANITIES, van'i-tiz** (הַבִּלְהוּ, *hebbel*, נָוֶן, *'āwen*, שָׁוְיָ, *shāw'*; κενός, *kenós*, ματαιότης, *mataiótēs*): The words "vain," "vanity," "vanities" are frequent in the Bible. Their idea is almost exclusively that of "evanescence," "emptiness,"

including "idolatry" and "wickedness" as being not only evil but vain and empty things. They also signify falseness. The chief word tr<sup>d</sup> "vanity," "vanities" is *hebbel*, a "breath of air, or of the mouth," often applied to idolatry (Dt 32 21; 1 K 16 13; Ps 31 6; Jer 8 19, etc); to man's days and to man himself (Job 7 16; Ps 39 5.11, etc); to man's thoughts (Ps 94 11); to wealth and treasures (Prov 13 11; 21 6); to everything, in Eccl, where the word occurs frequently in various applications: "Vanity of vanities, all is vanity" (Eccl 1 2; 12 8). *Hebbel* is also the name of Adam's second son (Gen 4 2). 'Awen, meaning also "breath," is likewise tr<sup>d</sup> "vanity" in similar connections, but it inclines more to "iniquity" (so often rendered); it is joined with mischief and iniquity (Isa 41 29; 58 9; Zec 10 2); another frequent word is *shāw'*, having also the idea of "falsity," "wickedness" (Ex 20 7; Dt 5 11; Ps 31 6, etc).

"Vanity" does not often occur in the NT; but see VAIN, VAINGLORY. In Acts 14 15 we have *mátaios*, "empty," tr<sup>d</sup> "vanities" (of idols); *mataiotēs*, "emptiness," "transitoriness" (Rom 8 20, "The creation was subjected to vanity," frailty, transitoriness); "emptiness," "folly" (Eph 4 17; 2 Pet 2 18).

Among other changes for "vanity" RV has "iniquity" (Job 15 35; Ps 10 7); "falsehood" (Ps 12 2; 41 6); "deceit" (144 8.11); "vapor" (Prov 21 6); "calamity" (22 8, m "vanity"); "a breath" (Isa 57 15); "wickedly" (58 9). Conversely, for "Wherefore hast thou made all men in vain?" (Ps 89 47), "For what vanity hast thou created all the children of men!"; for "Behold, they are all vanity; their works are nothing" (Isa 41 29), "Behold, all of them, their works are vanity and nought," m as AV, with "nought" for "nothing."

W. L. WALKER

VAPOR, vā'pēr: (1) נֶחֱל, 'ēdh: "For he draweth up the drops of water, which distil in rain from his vapor" (Job 36 27); "There went up a mist ['ēdh] from the earth, and watered the whole face of the ground" (Gen 2 6). (2) נֶשֶׁבַע, nāsēv, "vapor," i.e. that which rises, from נָסָא, nāsā, "to lift": "Who causeth the vapors to ascend from the ends of the earth" (Ps 135 7; cf Jer 10 13; 51 16); also tr<sup>d</sup> "clouds": "as clouds and wind without rain" (Prov 25 14). (3) In Job 36 33, AV has "vapour" ("concerning the vapour") for אֲלֵה, 'alāh, √ קָלָה, 'alāh, "to go up," where RV reads "concerning the storm that cometh up." (4) קִיטּוֹר, kītōr: "fire and hail, snow and vapor" (Ps 148 8); elsewhere, "smoke": "The smoke of the land went up as the smoke of a furnace" (Gen 19 28); "I am become like a wineskin in the smoke" (Ps 119 83). (5) ἀτμός, atmīs: "blood, and fire, and vapor of smoke" (Acts 2 19); "For ye are a vapor that appeareth for a little time, and then vanisheth away" (Jas 4 14). The first two of the preceding quotations are interesting as indicating the knowledge that vapor of water from the earth or sea is the source of the rain. Visible vapor, i.e. mist or fog, is much less common in Pal than in many other countries. In the mountains, however, esp. in Lebanon, mists are of frequent occurrence, appearing to those below as clouds clinging to the mountains.

ALFRED ELY DAY

VASHNI, vash'nī (וַשְׁנִי, washnī, see below; LXX B, Σαβελ, Sanet, A, Σαντ, Sant): Read in 1 Ch 6 28 AV (Heb 13) as the name of the firstborn son of Samuel. According to ver 33 (Heb 18) and 1 S 8 2, Samuel's eldest son was Joel, and the second Abijah. The explanation of this is that in 1 Ch 6 28 the word taken then as a proper name is really "and second"; so following LXX, Luc. and Syr we read (as RV), "And the sons of Samuel: the first-born, Joel, and the second Abijah."

VASHTI, vash'tī (וַשְׁתִּי, wash'tī; Ἀστίν, Astin; Old Pers "beautiful woman"): The former queen of Xerxes, whom he divorced. On the 7th day of a great feast which the king was giving to the assembled nobles of the empire and others, he commanded the seven chamberlains who served in his presence to bring the queen into the assembly. We are told (Est 1 11) that his purpose was "to show the peoples and the princes her beauty; for she was fair to look on." The king's command was met by Vashti with a mortifying refusal to obey. The reason which is sometimes assigned for her disobedience—that no man but the king was permitted to look upon the queen—is without foundation. Esther invites Haman on two occasions to accompany the king to a banquet at which she was present. Nor can it be said that there was any lack of recognition of Vashti's high dignity; the seven highest officials of the palace were sent to escort her. The refusal had to be visited with a punishment severe enough to reestablish the supremacy which it threatened to overthrow. She was, accordingly, divorced and dethroned.

There is no known reference to Vashti outside of Est. The suggestion has been made that Vashti was an inferior wife, or one of the royal concubines. There is nothing, however, to support it; and it is, besides, directly opposed to several statements in the narrative. She is always named "queen" (Est 1 9.11.12.15-18). It is only (ver 19) when the decree is proposed to repudiate and degrade her that she is called merely "Vashti." She also (ver 9) presides at the banquet for the women. It is evident, therefore, that in the palace of the women there was no higher personage than Vashti. JOHN URQUHART

VAT. See WINEVAT.

VAULT, vōlt (נֶצֶר, nāṣar, "to guard," "protest"): Isaiah's charge against Israel as "a people that . . . lodge in the secret places" (Isa 65 4, m "vaults," AV "monuments") probably refers to the custom of sleeping in sacred tombs or vaults of idol temples to learn the future through dreams by the method known as *incubation*. See DIVINATION, 6, (ii); 7, 1; FAMILIAR SPIRIT; WITCHCRAFT; and *Expos T*, IX, 157 ff.

VAULT OF EARTH. See ASTRONOMY, III, 1.

VAV, vāv. See WAW.

VEDAN, vē'dan (וֵדָן, wēdhān): A place-name occurring only in Ezk 27 19, "Vedan and Javan traded with yarn for thy wares." AV, taking the syllable *wē* as the Heb conjunction, renders "and Dan also." The text is in bad condition. Some read "Dedan," but Dedan is spoken of separately in the following verse. Assuming that Vedan is the correct reading, an identification may be conjectured with Waddan, also called *al-Abwā'*, between Mecca and Medina. It was the object of Mohammed's first expedition (*Ibn Hishām*, 415). The name contains that of the god Wadd who was worshipped chiefly by the Arab tribe Kalb. A. S. FULTON

VEHEMENT, vē'hē-ment, VEHEMENTLY, vē'hē-ment-li (וַהֲרִישִׁי, hārīshī; ἐπιπόθησις, epipóthēsis): "Vehement" (from Lat *vehere*, "to carry," or *ve*, "out of," and *mens*, "mind"), carried away by the mind or force of passion, occurs twice in the OT (Cant 8 6, AV "a most vehement flame" [jealousy]) as the tr of *shalhebbeth-yāh*, "the flame of Jeh," which perhaps means lightning (RV "a very flame of Jeh," m "a most vehement flame, *Heb Jah*"); and as the tr of AV *hārīshī*, "silent," "still," hence "sultry"

(Jon 4 8, AV "a vehement east wind," RV "sultry"). In the NT, "vehement desire" is (AV) the tr of *epípothēsis*, "earnest desire" (2 Cor 7 11, RV "longing").

"Vehemently" is the tr of *deinōs*, "greatly" (Lk 11 53); of *ek perissōi* or *ekperissōs*, "beyond measure" (Mk 14 31, "He spake exceeding vehemently"); of *eutōnōs*, "intensely" (Lk 23 10); and in AV of *prosrhēgnumi*, "to break" or "dash upon" (Lk 6 48.49, RV "break").

W. L. WALKER

**VEIL**, vāl: The following words are so tr<sup>d</sup> in EV (sometimes AV *vail*): (1) מִיִּפְחָת, *miṣpāhath*, Ruth 3 15 AV, RV "mantle." As the material was strong enough to serve as a bag for a large quantity of grain RV is certainly right; cf Isa 3 22. (2) מַשְׁוֶה, *mašveh*, Ex 34 33-35. St. Paul in his quotation of the passage in 2 Cor 3 13-16 uses κάλυμμα, *kálymma*, following LXX. The covering worn by Moses to conceal the miraculous brightness of his face, although, according to MT, he seems to have worn it only in private. (3) מַשְׁשֶׁהָה, *maššēkhāh*, Isa 25 7; in 28 20 tr<sup>d</sup> "covering." The use in 25 7 is figurative and the form of the "veil" a matter of indifference. (4) צַמְמָה, *ṣammāh*, RV Cant 4 1.3 (m "locks" [of hair]); 6 7; Isa 47 2, AV "locks." The meaning of the word is uncertain and AV may very well be right. If, however, RV's tr is correct, a light ornamental veil is meant. (5) צִיִּיפָה, *ṣā'īph*, Gen 24 65; 38 14.19. A large wrap is meant, which at times was used to cover the face also. In 24 65 Rebekah conformed to the etiquette which required the veiling of brides (see MARRIAGE). In ch 38 one motive for Tamar's use of the veil was certainly to avoid recognition, but it seems clear from the passage that veils were used by courtesans. Why is unknown, perhaps partly to conceal their identity, perhaps partly in parody of the marriage custom. (6) דִּיִּד, *ḏīḏīdh*, Cant 5 7 (RV "mantle," m "veil"); Isa 3 23. A light mantle is certainly meant. In Cant 5 7 it is torn from the maiden in the watchmen's endeavor to detain her. (7) παρακάλυμμα, *parakálymma*, Wisd 17 3 AV, RV "curtain." (8) Vb. κατακάλυπτο, *katakályptō*, 1 Cor 11 6 f, with ἀκατακάλυπτο, *akatakályptō*, "unveil" in ver 5; AV has "cover" and "uncover"; καλύπτω, *kályptō*, 2 Cor 4 3 (bis), ἀνακαλύπτω, *anakályptō*, 2 Cor 3 18; AV "hid" and "open."

It will be seen that there is a certain reference to what in modern times would be termed a "veil" only in (2) above. For a possible additional reference see MUFFLER.

The use of the face veil as a regular article of dress was unknown to the Heb women, and if "veil" is to be understood in Cant 4 1, etc, it was worn as an ornament only. The modern oriental custom of veiling is due to Mohammedan influence and has not been universally adopted by Jewesses in the Orient. In NT times, however, among both Greeks and Romans, reputable women wore a veil in public (Plutarch *Quaest. Rom.* xiv) and to appear without it was an act of bravado (or worse); Tarsus, St. Paul's home city, was especially noted for strictness in this regard (Dio of Prusa, *Tarsica prior*, §48). Hence St. Paul's indignant directions in 1 Cor 11 2-16, which have their basis in the social proprieties of the time. The bearing of these directions, however, on the compulsory use of the *hat* by modern women in public worship would appear to be very remote.

For the Veil of the Tabernacle and the Temple see next article. BURTON SCOTT EASTON

**VEIL**: (1) פֶּרֶקֶת, *pārōketh*; καταπέτασμα, *kata-pétasma*; AV *vail*: In Ex, Lev, Nu, the veil that hung between the two holy chambers of the

tabernacle is mentioned 23 t (Ex 26 31, etc). In several places it is termed "the veil of the screen," and it is distinguished from "the screen for the door of the tabernacle" (Ex 35 12.15; 39 34.38). By the latter is meant the curtain that hung outside the holy place, i.e. at the tabernacle entrance. Ex 26 31 informs us that the veil was made of fine-twined linen, and that its colors were blue and purple and scarlet. It was embroidered with cherubim. At each removal of the tabernacle the veil was used to enwrap the ark of the testimony (Nu 4 5). From its proximity to this central object of the Heb ceremonial system, the veil is termed "the veil of the testimony" (Lev 24 3), "the veil which is before the testimony" (Ex 27 21), etc. In Solomon's Temple the veil is mentioned but once (2 Ch 3 14). It was protected by doors of olive wood (1 K 6 31). In the later temple it is alluded to in 1 Macc 1 22. Its presence in Herod's temple is attested by the statement in each of the Synoptists that at the time of Christ's death the veil of the temple was rent from top to bottom, or in the midst (Mt 27 51; Mk 15 38; Lk 23 45; cf in Mish, *Mid.* ii.1; iv.7). This fact is the basis of the profound truth expressed by the writer to the Hebrews that Jesus, by His sacrificial death, opened for all believers a way into the holiest "through the veil, that is to say, his flesh" (He 10 20). See TABERNAACLE; TEMPLE. (2) See preceding art. and DRESS, V. W. SHAW CALDECOTT

**VEIN**, vān: Only in Job 28 1, AV "a vein for the silver," or מוֹצֵא, *mōṣā*, "going forth," "source." Both AV "vein" and RV "mine" are more specialized than *mōṣā*, but RV doubtless conveys the original meaning.

**VENGEANCE**, ven'jans. See AVENGE; GOEL; RETRIBUTION; REVENGE.

**VENISON**, ven'i-z'n, ven'z'n: Is derived (through the Fr. *venaison*) from the Lat *venari*, "to hunt," and means properly "the spoils of the chase." As, however, the object of the chase, *par excellence*, was the deer, venison came to mean usually (as it invariably does in modern Eng.) "deer's flesh." But in EV this technical force seems not to be implied, for "venison" is used only for the two Heb words צֵדִיחַ, *ṣayidh* (Gen 25 28; 27 5 ff), and דְּבַר־צֹדִיחַ, *ḏēbhār-ṣōḏīdh* (Gen 27 3), and both these words (from צָוֵד, *ṣūdh*, "to hunt") mean simply "game" of any kind.

**VERDIGRIS**, vūr'di-grēs. See SCUM.

**VERILY**, ver'i-li, **VERITY**, ver'i-ti (בְּבִלְיָא, *'ābhāl*, etc; אֱמֵן, *āmēn*): "Verily," as confirmatory advb., represents various Heb and Gr words and particles (*'ābhāl*, "truly," in Gen 42 21, etc; *'akh*, "only," "surely," in Ps 66 19; Isa 45 15, etc). For AV "verily thou shalt be fed" (Ps 37 3, where *'ēmūnāh*), ARV has "feed on his faithfulness" and ERV "follow after faithfulness," m in both "feed securely." The Gr *āmēn* (Heb *'āmēn*) is used very frequently in the Gospels as an emphatic confirmation of Christ's sayings (Mt 5 18.26; 6 2; Mk 3 28, etc), and in John's Gospel is repeated to give additional emphasis (Jn 1 51; 3 3.5.11, etc). RV makes various changes, as "wholly" for "verily" (Job 19 13), "surely" (Ps 39 5; 73 13), "indeed" (Mk 9 12; Rom 2 25; He 3 5; 7 5), etc, and sometimes puts "verily" where AV has other words, as "also" (Mt 13 23), "doubtless" (Phil 3 8), etc.

Verity is the tr of *'emeth*, "truth," "steadfastness" (Ps 111 7, "The works of his hands are verity and judgment," ARV "truth and justice," ERV "truth and judgment"); and of *alētheia*, "truth," "reality,"

"certainty" (1 Tim 2 7), "faith and verity," RV "faith and truth." W. L. WALKER

**VERMILION**, vēr-mil'yun. See **COLORS**, (3).

**VERSIONS**, vûr'shunz. See **AMERICAN REVISED VERSION**; **ARABIC VERSIONS**; **ARMENIAN VERSIONS**; **COPTIC VERSIONS**; **ENGLISH VERSIONS**; **ETHIOPIC VERSIONS**; **LATIN VERSION, THE OLD**; **SEPTUAGINT**; **SYRIAC VERSIONS**; **TARGUM**; **TEXT OF THE NT**; **TEXT OF THE OT**; **VULGATE**.

**VERSIONS, GEORGIAN**, jôr'ji-an, **GOTHIC**, goth'ik, **SLAVONIC**, sla-von'ik: Georgia is the name given to the territory extending to the E. of the Black Sea, a country that has had an independent national existence of 2,000 years but is now (under the name Grusinia) a part of the trans-Caucasian domain of Russia. The language has no affinities with any of the recognized groups, but is becoming obsolete under Russian pressure. Christianity was introduced into Georgia in the 4th cent., and a national conversion followed. A well-supported tradition makes the first tr of the Bible almost contemporaneous with this conversion and refers it to St. Mesrop (d. 441; see **ARMENIAN VERSIONS**), but the fact is not quite certain and the beginnings of a native VS may really be as much as two centuries later. The oldest MS extant is a Psalter of the 7th-8th cent., and the earliest copy of the Gospels is perhaps a century later; in all, Gregory (*Textkritik*, 573-75) enumerates 17 Georgian MSS of the NT, but his list is not exhaustive. The first printed Bible was produced in the ancient alphabet in Moscow in 1743 and has never been reprinted, but other edd, perhaps only of the NT, were issued at least in 1816 and 1818, using the non-ecclastical alphabet. According to Conybeare (*ZNTW*, XI, 161-66, 232-39 [1910]) the Georgian VS was first made from the Old Syr and then later (11th cent.) revised from the Gr. In 1910 a new edition, based on two MSS dated respectively 913 and 995, was begun (*Quattuor Ev. versio Georgia vetus*, St. Petersburg). The Georgian VS was used by S. C. Malan, *The Gospel according to St. John Tr<sup>d</sup> from the 11 Oldest VSS*, London, 1862.

Ufilas, the Arian bishop of the West Goths and the chief agent in their conversion to Christianity, was also the first translator of the Bible into Gothic, a work for which he had even to invent an alphabet. According to tradition, his tr included the entire Bible with the exception of K (which he thought unadapted to the already too warlike character of his converts), but there is doubt whether his work actually included more than the NT. Too little of the OT has survived to enable a settling of this question, nor is it possible to tell how much revision the NT tr has undergone since Ufilas' work. A list of the six Gothic MSS is given in *HDB*, IV, 862, to which is to be added a bilingual Lat-Gothic MS containing portions of Lk 24, known as the Arsinoë Fragment (published in *ZNTW*, XI, 1-38 [1910] and separately [Giessen, 1910]). In all there have been preserved in the OT Gen 5 (in part); Ps 52 2 f; Neh 5-7 (in part), and in the NT the Gospels and Pauline Epp. (all incomplete), with quotations from He. The best complete ed is that of Stamm-Heyne<sup>9</sup> (Paderborn, 1896), but as the VS is of basic importance for the history of the Germanic languages there are many edd of various portions prepared for philological purposes.

The OT fragments are a tr of a text very closely allied to the Lucianic Gr (see **SEPTUAGINT**) and are certainly not from the Heb. The NT undoubtedly

was made from a text of the type used in Antioch (Constantinople) in the 4th cent., with very slight variations, none of which are "neutral" (von Soden classes them as of the I-type). Either in making the tr or (more probably) in a subsequent revision an Old-Lat text was used, of the type of Codex Brixianus (f), and certain Old-Lat readings are well marked. For brief lists of these peculiarities see Burkitt in *Jour. Theol. Studies*, I, 129-34 (1900), or von Soden, *Schriften des NT*, I, 1469 f (1906).

It is definitely known that the first Slavonic tr of the Bible was commenced in 864 or earlier by the two brothers Cyril (d. 869) and Methodius (d. 885), and that the latter worked on it after the former's death. Their work was undertaken for the benefit of the Balkan Slavs, and at first only the liturgical portions (Gospels, Acts, Epp. and Ps) were tr<sup>d</sup>, but, after the completion of this, Methodius carried the tr farther to include larger portions of the OT. How much of this he accomplished is obscure, but he seems not to have finished the OT entirely, while almost certainly he did not translate Rev. Uncertain also is the exact dialect used for this work; although this dialect was the basis of the present liturgical language of the Russian church, it has undergone much transformation before arriving at its final stage. At different times the tr of the Bible was revised to conform to the changes of the language, in addition to other revisional changes, and, as a result, the MSS (some of which go back to the 10th cent.) exhibit very varying types of text that have not been satisfactorily classified.

An attempt to bring the discrepant material into order was made about 1495 by Archbishop Gennadius, but he was unable to find Slavonic MSS that included the entire Bible and was forced to supply the deficiencies (Ch, Ezz, Neh, Est and most of Jer and the Apoc) by a new tr made from the Vulg. This Bible of Gennadius was the basis of the first printed edition, made at Ostrog in 1581, although the liturgical portions had been printed earlier (Acts and Epp. first of all in 1564). The Ostrog ed followed Gennadius fairly closely, but Est, Cant and Wisd were new tr<sup>s</sup> made from the LXX. The next revision was undertaken by order of Peter the Great and was performed by using the Gr (OT and NT); although the resulting text was not printed until 1751. A slightly emended ed of 1756 is still the official Bible of the Russian church.

This Slavonic VS is to be distinguished from the VS in the true Russian language, begun first in 1517, revised or remade at various times, with an excellent modern tr first published complete in 1876. See, on the whole subject, esp. Bebb in *Church Quart. Rev.*, XLI, 203-25, 1895.

**LITERATURE**.—On all three VSS see *HDB*, IV, 861-64, 1902, and the art. "Bibelübersetzung" in *PRE<sup>3</sup>*, III (1897), with the important supplement in XXIII (1913).

BURTON SCOTT EASTON

**VERY**, ver'i: As adj. (from *verus*, "true"), "true," "real," "actual," etc (Gen 27 21,24, "my very son Esau"; Josh 10 27, "this very day"; Jn 7 26, "the very Christ," etc); chiefly as advb., "in a high degree," "extremely." As advb. it is commonly in the OT the tr of מְאֹד, *m'ôdh*, and in the NT represents, as adj. and advb., several Gr words, as *alēthōs*, "truly" (Jn 7 26, above), *autōs* (Jn 14 11, "the very works' sake"; Rom 13 6), *sphōdra* (Mt 18 31, "very sorry," RV "exceeding sorry"; Mk 16 4, "very great," RV "exceeding"), *hupēr*- (in composition 1 Thess 5 13), etc. RV frequently omits "very," and also substitutes other words for it, as "exceeding" (2 Ch 16 8; Mt 26 7; cf above), "sore" (Zec 9 5), etc.

W. L. WALKER

**VESSEL**, ves'el: Is used freely in EV to translate כֶּלִי, *kēlī*, the Aram. מְנָחָה, *mā'n*, and σκεῦος, *skeúos*, words all meaning "an implement or utensil" of any kind, when the context shows that a hollow utensil is meant. In 1 S 21 5, however, the tr of the pl. of *kēlī* by "vessels" is dubious. EV evidently intended something in the nature of provision wallets, and the "holiness" of such objects finds partial parallels in Nu 19 15; Lev 11 32-34, etc. But in 1 S 21 8, in the immediate context of the verse above, *kēlī* certainly means "weapons," and this tr is quite intelligible in ver 5 also. For war among the Hebrews was a holy function, calling for extreme ceremonial purity (Dt 23 9-14). See the comms. and esp. *RŠ*<sup>2</sup>, 455-56. In addition, "vessel" appears in Isa 30 14 for נֶבֶל, *nehel*, "jar"; in Mt 13 48 for ἀγγος, *aggos*, "vessels"; and in Sir 21 14; Mt 25 4 for ἀγγείων, *aggelōn*, a dimin. form of *aggos*. A different use is that of Wisd 14 1, where "vessel" represents πλοῖον, *plōion*, "a boat," while Wisd 14 5.6 AV has "weak vessel" for σκεῦα, *schedia*, "raft" (so RV). Vessels of all sorts and kinds and for all sorts of uses were so familiar as to make them natural illustrations for different sorts of human beings (Hos 8 8; Isa 22 24; Jer 22 23, etc.; see POTTER), and through Acts 9 15 the word "vessel" has passed into Christian theology as signifying simply a human being. But the figure of such "vessels" as (passively) filled with different contents is not Bib. In 1 Thess 4 4 "vessel" may be taken as a figure for either the man's own body or for his wife. Between these possibilities the comms. are almost equally divided.

BURTON SCOTT EASTON

**VESTMENTS**, vest'ments. See DRESS.

**VESTRY**, ves'tri (מִלְתָּחָה, *meltāhāh*): Once, in 2 K 10 22, as a place for vestments.

**VEX**, veks, **VEEXATION**, vek-sā'shun: "Vex," meaning originally to shake or toss in carrying, has a much more intensive meaning in Scripture than in common modern usage. It represents over a score of Heb and Gr words, most of them tr<sup>d</sup> by this word only once, and many of them changed in RV into other forms. Thus *bāhēl* in Ps 6 2.3.10 is in ARV "troubled" (in Ps 2 5, RVm "trouble"); *cārar* in Neh 9 27 is in RV "distressed"; *pāschō* in Mt 17 15 is "suffereth grievously"; *kakōō* in Acts 12 1 is "afflict," etc. So "vexation only" in Isa 28 19 is in RV "nought but terror," and there are other changes of this word (cf Dt 28 20, "discomfiture"; Isa 9 1, "in anguish"). On the other hand, RV has "vex" for "distress" (Dt 2 9.19); "they that vex" for "the adversaries of" (Isa 11 13); "vexeth himself" for "meddled" (Prov 26 17), etc.

W. L. WALKER

**VIAL**, vī'al: In modern Eng. means "a tiny flask." The word appears in EV 1 S 10 1 and RV 2 K 9 1.3 (AV "box") for פַּךְ, *pakh*, a word found nowhere else and from a root meaning "to pour." The shape and size of the *pakh* are quite uncertain. In 1 Esd 2 13; and AV Rev 5 8, etc., "vial" translates φιάλη, *phiālē*. The *phiālē* was a flat, shallow bowl (Lat *palera*), shaped much like a saucer. Hence RV's change to "bowl" in Rev, a change that should have been made in 1 Esd also.

**VICE, UNNATURAL**. See UNNATURAL VICE.

**VICTUALS**, vit'lz. See FOOD.

**VILE**, vil, **VILLANY**, vil'an-i: The original words for "vile" and "villany" are used in about 10 different senses, e.g. despised (1 S 15 9), despicable

(Dnl 11 21 AV), lightly esteemed (Dt 25 3), empty (Jgs 19 24 AV), foolish (Isa 32 6, AV and ERV), dishonorable (Rom 1 26), filthy or dirty (Jas 2 2), humiliation (Phil 3 21).

Villany occurs but twice in AV (Isa 32 6; Jer 29 23), and signifies emptiness or folly (so RV). From the foregoing meanings it will be seen that the word "vile" does not always bear the meaning which has come to be invariably given it in our present-day speech. Anything common or ordinary or humble might, in the Scriptural sense, be termed "vile." So Job 40 4, RV "Behold, I am of small account"; also "the low estate of his handmaid" (Lk 1 48). Ordinarily, however, the idea of contemptible, despicable, is read into the word.

WILLIAM EVANS

**VILLAGE**, vil'āj (קָפָר, *kāphār*, חַוּוֹת, *hawwōth*, מְצָרִים, *hācērīm*, בְּנוֹת, *bānōth*, פְּרָזוֹת, *prāzōth*; κάμη, *kōmē*): (1) The general term for a village, in common with Aram. and Arab., is *kāphār* (Cant 7 11; 1 Ch 27 25; *kōpher*, 1 S 6 18; *kāphār*, Neh 6 2). This designation is derived from the idea of its offering "cover" or shelter. It is used in combination, and place-names of this formation became prominent in post-Bib. times, probably because the villages so named had then grown into towns. A well-known Bib. instance of such names is Capernaum. (2) *Hawwōth* (always "town" in EV; see HAVVOOTH-JAIR) means originally a group of tents (Arab. *hūwa*). These in settled life soon became more permanent dwellings, or what we understand by a village. The term, however, is applied only to the villages of Jair in the tribe of Manasseh (Nu 32 41; 1 K 4 13). (3) *Hācērīm* likewise came from nomadic life. They were originally enclosures specially for cattle, alongside of which dwellings for the herdsmen and peasantry naturally grew up (see HAZAR-ADDAR; HAZOR). They were unwall'd (Lev 25 31) and lay around the cities (Josh 19 8). (4) *Bānōth* is lit. "daughters." The word is applied to the dependent villages lying around the larger cities, and to which they looked as to a kind of metropolis (Nu 21 25, etc); RV "towns" except in Nu 32 42. (5) *Prāzōth* means "the open country," but it soon came to mean the villages scattered in the open (Ezk 38 11; Zec 2 4; Est 9 19). Some have sought to connect the Perizzites with this word and to regard them, not as a distinct people, but as the peasant class. Attempts have also been made to connect *prāzōn* in Jgs 5 7.11 with the same root, and AV rendered it "inhabitants of the villages." RV, on the contrary, gives it the meaning of "rulers." The VSS indicate a word meaning authority, and probably the text should be emended to read *rōz'nīm*, "rulers." A similar emendation is required in Hab 3 14. "Village" in RV of the NT invariably represents the Greek *kōmē*, but in 2 Macc 8 6 the RV Apoc has "village" for *chōra*, lit. "country." See CITY; TOWN.

W. M. CHRISTIE

**VILLANY**. See VILE.

**VINE**, vīn:

(1) גֵּפֶן, *gephen*, usually the cultivated grape vine. In Nu 6 4; Jgs 13 14 we have גֵּפֶן הַיַּיִן, *gephen ha-yayīn*, lit. "vine of wine,"

1. Hebrew tr<sup>d</sup> "grape vine" (Nu) and "vine," Words m "grape vine" (Jgs); 2 K 4 39,

גֵּפֶן שָׂדֵה, *gephen sādheh*, EV "wild vine"; Dt 32 32, גֵּפֶן סוּדוֹם, *gephen š'dhōm*, "vine of Sodom."

(2) שֵׁרֶק, *sōrēk*, in Isa 5 2, "choicest vine"; שֵׁרֶק, *sōrēk*, in Jer 2 21, "noble vine"; שֵׁרֶקָה, *sōrēkāh*, in Gen 49 11, "choice vine"; cf VALLEY

of SOREK (q.v.). The Heb is supposed to indicate dark grapes and, according to rabbinical tradition, they were unusually sweet and almost, if not quite, stoneless.

(3) נָזִיר, *nāzīr*, in Lev 25 5.11, "undressed vine," AV "vine undressed," m "separation." This may mean an unpruned vine and be a reference to the unshorn locks of a Nazirite, but it is equally probable that נָזִיר should be בָּצִיר, *bāzīr*, "vintage."

For the blossom we have פֶּרַח, *perah* (Isa 18 5), "blossom"; נִצְחָה, *niṣṣāh*, either the blossom or half-formed clusters of grapes (Gen 40 10; Isa 18 5); רִמְדָּה, *ṣemādhar*, "sweet-scented blossom" (Cant 2 13.15; 7 12).

For grapes we have commonly: עֵנָב, *'ēnābh* (a word common to all Sem languages) (Gen 40 10; Dt 32 14; Isa 5 2, etc); דָּם עֵנָבִים, *dam 'anābhīm*, lit. "blood of grapes," i.e. wine (Gen 49 11); בֹּשֶׂר, *bōsher*, "the unripe grape" (Isa 18 5, "ripening grape," AV "sour grape"; Job 15 33, "unripe grapes"; Jer 31 29 f; Ezk 18 2, "sour grapes"); בְּאֲשֵׁים, *b'ushīm*, "wild grapes" (Isa 5 2.4; see GRAPES, WILD); אֶשְׁכּוֹל, *'eshkōl*, a "cluster" of ripe grapes (Gen 40 10; Cant 7 8 f; Hab 3 17, etc; cf ESHCOL [q.v.]); חַרְצָנִים, *harṣannīm*, usually supposed to be the kernels of grapes (Nu 6 4).

In Gr we have ἀμπέλος, *ampelos*, "vine" (Mt 26 29, etc), σταφυλή, *staphulē* (Sir 39 26, "blood of grapes"; Mt 7 16, "grapes," etc), and βότρυς, *bōtrus* (Rev 14 18), "cluster and Latin of the vine." In the Lat of 2 Esd *vinea* is "vine" in 5 23 ("vineyard" in 16 30.43); *botrus* (9 21) and *racemus* (16 30) are "cluster"; *acinium* (9 21) and *wa* (16 26) are "a grape."

Pal appears to have been a vine-growing country from the earliest historic times. The countless wine presses found in and around centers of early civilization witness to this. It is probable that the grape was largely cultivated as a source of sugar: the juice expressed in the "wine press" was reduced by boiling to a liquid of treacle-like consistency known as "grape honey," or in Heb *d'bbash* (Arab. *dibs*). This is doubtless the "honey" of many OT references, and before the days of cane sugar was the chief source of sugar. The whole OT witnesses to how greatly Pal depended upon the vine and its products. Men rejoiced in wine also as one of God's best gifts (Jgs 9 13; Ps 104 15). But the Nazirite might eat nothing of the vine "from the kernels even to the husk" (Nu 6 4; Jgs 13 14).

The land promised to the children of Israel was one of "vines and fig trees and pomegranates" (Dt 8 8); they inherited vineyards which they had not planted (Dt 6 11; Josh 24 13; Neh 9 25). Jacob's blessing on Judah had much reference to the suitability of his special part of the land to the vine (Gen 49 11). When the leading people were carried captive the poor were left as vine dressers (2 K 25 12; Jer 52 16), lest the whole land should lapse into uncultivated wilderness. On the promised return this humble duty was, however, to fall to the "sons of the alien" (Isa 61 5 AV).

The mountain regions of Judaea and Samaria, often little suited to cereals, have always proved highly adapted to vine culture. The stones must first be gathered out and utilized for the construction of a protecting wall or of terraces or as the bases of towers (Isa 5 2; Mt 21 33). Every ancient vineyard had its wine press cut in a sheet of

rock appearing at the surface. As a rule the vine-stocks lie along the ground, many of the fruit-bearing branches falling over the terraces (cf Gen 49 22); in some districts the end of the vine-stock is raised by means of a cleft stick a foot or more above the surface; exceptionally the vine branches climb into



Large Vine at Jericho. Age 333 Years. Length of Trunk, 9 ft. 7 in.; Girth of Trunk at Base, 53 in.; Girth of Trunk Half-Way Up, 38 in.

trees, and before a dwelling-house they are sometimes supported upon poles to form a bower (cf 1 K 4 25, etc).

The cultivation of the vine requires constant care or the fruit will very soon degenerate. After the rains the loosely made walls require to have breaches repaired; the ground must be ploughed or harrowed and cleared of weeds—contrast with this the vineyard of the sluggard (Prov 24 30-31); in the early spring the plants must be pruned by cutting off dead and fruitless branches (Lev 25 3.4; Isa 5 6) which are gathered and burned (Jn 15 6). As the grapes ripen they must be watched to keep off jackals and foxes (Cant 2 15), and in some districts even wild boars (Ps 80 13). The watchman is stationed in one of the towers and overlooks a considerable area. When the grape season comes, the whole family of the owner frequently take their residence in a booth constructed upon one of the larger towers and remain there until the grapes are practically finished. It is a time of special happiness (cf Isa 16 10). The gleanings are left to the poor of the village or town (Lev 19 10; Dt 24 21; Jgs 8 2; Isa 17 6; 24 13; Jer 49 9; Mic 7 1). In the late summer the vineyards are a beautiful mass of green, as contrasted with the dried-up parched land around, but in the autumn the leaves are sere and yellow (Isa 34 4), and the place desolate.

The expression "vine of Sodom" (Dt 32 32) has been supposed, esp. because of the description in Jos (BJ, IV, viii, 4), to refer to the colocynth (*Citrullus colocynthis*), but it is far more probable that it means "a vine whose juices and fruits were not fresh and healthy, but tainted by the corruption of which Sodom was the type" (Driver, *Comm. on Dt*). See SODOM, VINE OF.

**4. Its Cultivation**  
utilized for the construction of a protecting wall or of terraces or as the bases of towers (Isa 5 2; Mt 21 33). Every ancient vineyard had its wine press cut in a sheet of

**Figurative:** Every man "under his vine and under his fig-tree" (1 K 4 25; Mic 4 4; Zec 3 10) was a sign of national peace and prosperity. To plant vineyards and eat the fruit thereof implied long and settled habitation (2 K 19 29; Ps 107 37; Isa 37 30; 65 21; Jer 31 5; Ezk 28 26; Am 9 14); to plant and not eat the fruit was a misfortune (Dt 20 6; cf 1 Cor 9 7) and might be a sign of God's displeasure (Dt 28 30; Zeph 1 13; Am 5 11). Not to plant vines might be a sign of deliberate avoidance of permanent habitation (Jer 35 7). A successful and prolonged vintage showed God's blessing (Lev 26 5), and a fruitful wife is compared to a vine (Ps 128 3); a failure of the vine was a sign of God's wrath (Ps 78 47; Jer 8 13; Joel 1 7); it might be a test of faith in Him (Hab 3 17). Joseph "is a fruitful bough, . . . his branches run over the wall" (Gen 49 22). Israel is a vine (Isa 5 1-5) brought out of Egypt (Ps 80 8 f; Jer 2 21; 12 10; cf Ezk 15 2.6; 17 6). At a later period vine leaves or grape clusters figure prominently on Jewish coins or in architecture.

Three of Our Lord's parables are connected with vineyards (Mt 20 1 ff; 21 28.33 ff), and He has made the vine ever sacred in Christian symbolism by His teaching regarding the true vine (Jn 15).

E. W. G. MASTERMAN

**VINEGAR**, vin'ĕ-gēr (וֵינָיִם, *hōmeç*; ὄξος, *ózos*): Vinegar, whose use as a condiment (Ruth 2 14) needs no comment, is formed when a saccharine fluid passes through a fermentation that produces acetic acid. In the ancient world vinegar was usually made of wine, although any fruit juice can be utilized in its manufacture, and "vinegar of strong drink" (palm juice?) is mentioned in Nu 6 3. Undiluted vinegar is of course undrinkable, and to offer it to a thirsty man is mockery (Ps 69 21), but a mixture of water and vinegar makes a beverage that was very popular among the poor (Gr *oxos*, *oxúkraton*, Lat *posca*—names applied also to diluted sour wine). It is mentioned in Nu 6 3 (forbidden to the Nazirite) and again in the Gospels in the account of the Crucifixion. The executioners had brought it in a vessel (Jn 19 29) for their own use and at first "offered" it to Christ, while keeping it out of reach (Lk 23 36). But at the end the drink was given Him on a sponge (Mk 15 36; Mt 27 48; Jn 19 29.30). In addition, AV, following TR, has "vinegar . . . mingled with gall" in Mt 27 34, but this rests on a false reading, probably due to Ps 69 21, and RV rightly has "wine." Vinegar, like all acids, is injurious to the teeth (Prov 10 26); and when it is combined with niter an effervescence is produced (Prov 25 20). The appropriateness of the last figure, however, is obscure, and LXX reads "as vinegar on a wound," causing pain.

BURTON SCOTT EASTON

**VINEYARD**, vin'yard. See VINE.

**VINEYARDS, MEADOW (PLAIN) OF THE** (Jgs 11 33). See ABEL-CHERAMIM; MEADOW.

**VINTAGE**, vin'táj. See VINE.

**VIOL**, vi'ol (וִיּוֹל, *nehhel*, וִיּוֹל, *nehhel*): AV and RV in Isa 14 11; Am 5 23; 6 5; AV alone in Isa 5 12, RV "lute." "Viol" is derived from Lat *vitella*, a doublet of *vitula*, a "viol"; hence Fr. *vielle*, doublet of *viole*. The viol was a bowed instrument, the parent of the violin tribe, and is not a true equivalent for *nehhel*. See MUSIC.

**VIOLENCE**, vi'ô-lens, **VIOLENT**, vi'ô-lent: Chiefly for וְזָלַז, *gāzal*, וְזָמַס, *hāmas*; βία, *bia*, and their derivatives. Difficulty is offered only by the

very obscure passage Mt 11 12 || Lk 16 16. Both Mt and Lk contain the vb. βιάζεσθαι, *biázetai*, but this form may be either a middle, "presses violently," "storms," or a passive, "is forced." Mt, in addition, contains the adj. *biástai*, but whether this is a term of praise, "heroic enthusiasts," or of blame, "hot-headed revolutionaries," is again a problem. Nor can it be determined whether the words "from the days of John the Baptist until now" are meant to include or exclude the work of the Baptist himself. The difference in wording in Mt and Lk further complicates the problem, and, in consequence, scholars are widely at variance as to the proper interpretation. "The Baptist has fanned a new Messianic storm of ill-advised insurrection," "the Pharisees have shamefully used forcible suppression of God's teachers," "the Kingdom of God comes like a storm and is received by those who have used drastic self-discipline," are instances of the differing explanations proposed.

BURTON SCOTT EASTON

**VIPER**, ví'pēr (וִיפֵר, *'eph'eh* [Job 20 16; Isa 30 6; 59 5]; ἔχιδνα, *échidna* [Mt 3 7=Lk 3 7; Mt 12 34; 23 33; Acts 28 3]): Several vipers are found in Pal, but it is not certain that *'eph'eh* referred definitely to any of them. See SERPENT.

**VIRGIN**, vúr'jin, **VIRGINITY**, vúr-jin'i-ti: (1) בְּתוּלָה, *bethuláh*, from a root meaning "separated," is "a woman living apart," i.e. "in her father's house," and hence "a virgin." *Bethuláh* seems to have been the technical term for "virgin," as appears from such a combination as *na'aráh bethuláh*, "a damsel, a virgin," in Dt 22 23.28, etc. An apparent exception is Joel 1 8, "Lament like a virgin [*bethuláh*] . . . for the husband of her youth," but the word is probably due to a wish to allude to the title "virgin daughter of Zion" (the tr "a betrothed maiden" is untrue to Heb. sentiment). And the use of "virgin" for a city (Isa 37 22, etc; cf Isa 23 12; 47 1) probably means "unsubdued," though, as often, a title may persist after its meaning is gone (Jer 31 4). AV and ERV frequently render *bethuláh* by "maiden" or "maid" (Jgs 19 24, etc), but ARV has used "virgin" throughout, despite the awkwardness of such a phrase as "young men and virgins" (Ps 148 12). For "tokens of virginity" ("proofs of chastity") see the comm. on Dt 22 15 ff. (2) עַלְמָה, *'almáh*, rendered in RV by either "damsel" (Ps 68 25), "maiden" (so usually, Ex 2 8, etc), or "virgin" with m "maiden" (Cant 1 3; 6 8; Isa 7 14). The word (see OHL) means simply "young woman" and only the context can give it the force "virgin." This force, however, seems required by the contrasts in Cant 6 8, but in 1 3 "virgin" throws the accent in the wrong place. The controversies regarding Isa 7 14 are endless, but LXX took *'almáh* as meaning "virgin" (*parthénos*). But in NT times the Jews never interpreted the verse as a prediction of a virgin-birth—a proof that the Christian faith did not grow out of this passage. See IMMANUEL; VIRGIN-BIRTH. (3) παρθένος, *parthénos*, the usual Gr word for "virgin" (Jth 16 5, etc; Mt 1 23, etc). In Rev 14 4 the word is masculine. In 1 Cor 7 25 ff RV has explained "virgin" by writing "virgin daughter" in vs 36-38. This is almost certainly right, but "virgin companion" (see Lietzmann and J. Weiss in loc.) is not quite impossible. (4) *veávis*, *neánis*, "young woman" (Sir 20 4). (5) Lat *virgo* (2 Esd 16 33).

The OT lays extreme emphasis on chastity before marriage (Dt 22 21), but childlessness was so great a misfortune that death before marriage was to be bewailed (Jgs 11 37.38). St. Paul's preference for the unmarried state (1 Cor 7 29 ff) is based

on the greater freedom for service (cf Mt 19 12), and the Gr estimate of virginity as possessing a religious quality *per se* is foreign to true Jewish thought (such a passage as Philo *Mund. opif.*, § 53, is due to direct Gr influence). Some have thought to find a trace of the Gr doctrine in Rev 14 4. But 144,000 1st-cent. Christian ascetics are out of the question, and the figure must be interpreted like that of Jas 4 4 (reversed).

BURTON SCOTT EASTON

### VIRGIN-BIRTH (OF JESUS CHRIST):

- I. DEFINITION
- II. THE TEXTUAL QUESTION
- III. THE HISTORICAL QUESTION
  1. Statement Not Dogmatic but Vital as History
  2. Its Importance to Leaders of the Early Church
  3. Hypothesis of Invention Discredits the Church
- IV. THE CRITICAL QUESTION
  1. Basis of Virgin-Birth Statement
  2. Interrelationship of Narratives
  3. Sources, Origin and Age of Documents
- V. THE DOCTRINAL QUESTION
  1. In the NT
  2. Portrait of Jesus in Synoptic Gospels
  3. In Rest of the NT
  4. Oppositions to the Doctrine
  5. Its Importance to Modern Thought

#### LITERATURE

**I. Definition.**—"Virgin-birth" is the correct and only correct designation of the birth statement contained in the Gospels of Mt and Lk. "Immaculate conception" is of course manifestly a blunder due to the confusion of one idea with another. "Supernatural or miraculous birth" will not do, because there is no intimation that the process of birth was in any way exceptional. "Supernatural or miraculous conception" is equally unsatisfactory as it involves a question-begging comparison between the birth of Christ and the exceptional births of the Sons of Promise (e.g. Isaac, John the Baptist, etc.). The only statement which is sufficiently specific is "virgin-birth," inasmuch as according to the NT statement Mary was at the time of this birth *virgo intacta*.

**II. The Textual Question.**—We may deal with this division of our subject very briefly, because if we are to allow any weight at all to textual evidence there is no question as to the infancy narratives, either in whole or in part. Their position is flawless and unassailable. There is a voluminous literature devoted to the discussion of the subject, but it is notably jejune even for critical writing, and much more impressive for ingenuity and dialectic skill in arguing a poor case than for anything in the way of results. We do not hesitate to refer the reader who is interested in discussions of this sort to entirely satisfactory reviews of them found elsewhere (see Machen, *Princeton Review*, October, 1905; January, 1906; and Orr, *The Virgin Birth of Christ*). We may summarize the entire discussion in the words of Johannes Weiss (*Theologische Rundschau*, 1903, 208, quoted by Machen, *ut sup.*): "There never were forms of Mt and Lk without the infancy narratives." One point only we shall consider in this connection; namely, the disputed reading of Mt 1 16. The Ferrar group of MSS (nos. 346, 556, 826, 828) interpose a second "begat" between the names Joseph and Jesus. It is affirmed that this reading with the variants represents an original form of the genealogy preserved in the Gospels which affirms the literal sonship of Jesus to Joseph. The first and most obvious remark to be made upon this question is, granting—that is extremely uncertain—that this reading is original, it does not prove nor begin to prove the point alleged. This is now widely conceded. For one thing, the word "begat" is used elsewhere for legal or putative fatherhood (cf ver 12 and see GENEALOGY OF JESUS CHRIST). Allen's statement of the case indicates clearly enough that the radical

use of this variation has broken down (see *ICC*, "Matthew," 8). This writer holds that the reading of S 1 ("Jacob begat Joseph. Joseph, to whom was betrothed Mary the Virgin, begat Jesus, called the Messiah," Mt 1 16) is nearest the original form. By four steps, which he enumerates in order, he conceives that the original text, which was intended to convey the idea of a *legal* fatherhood on the part of Joseph, was modified so as to guard the statement from misinterpretation. This hypothesis is ingenious if somewhat complicated. The weak spot in the whole case (for the variation) lies in the fact that all MSS concur in the name of Mary and the term "virgin." It is evident, in any view of the relative standing of the various readings, (1) that the genealogy as deposited in public or private record would read: "Jacob begat Joseph, Joseph begat Jesus," (2) that the person who used the genealogy in the Gospel and placed it in connection with vs 18-25 (a) had Mary particularly in mind and inserted the names of women to prepare the way for the mention of Mary, all of which was a departure from usual and orderly procedure; (b) that he used the word "begat" in the legal sense throughout (vs 8.12; cf 1 Ch 3 11.12.19); (c) that he believed in the virgin-birth as evinced by the connection and the use of names of women including Mary's. There is therefore no basis for the idea that the genealogy, even without the strongly attested relative clause of 1 16, ever meant anything but an attestation of the virgin-birth.

**III. The Historical Question.**—The twofold birth announcement of Mt and Lk is a statement of historical or, more strictly speaking, biographical fact. The accounts, as we shall see, are very rigidly confined to the matter of fact concerned. It is not a dogma and receives very little doctrinal elaboration even in the infancy narratives themselves. It is an event, wholly real or wholly imaginary. The statement of it is wholly true or entirely false. But as a historical statement this narrative is of peculiar quality and significance. (1) It touches upon the most delicate matters, at a place where the line between that which is most sacred and that which is most degraded in human life is closely drawn. To discredit it leaves the most intimate mystery of Our Lord's earthly life under the shadow of suspicion. It is therefore a statement of the greatest personal moment in the evangelic record. (2) It involves the secret history and public honor of a family most dear and sacred to the entire Christian body. It records the inner and outer experiences of the mother of the Lord and of His brethren, themselves honored leaders in the church. (3) It touches upon the central mystery of the Lord's person in such a way as to involve either a very important contribution to the doctrine of the incarnation or a very serious mutilation of the truth. We may dismiss altogether the contention of many, that whether true or not the fact is of no great importance. It must be of importance. No fact in which the relationship of Jesus to His ancestors according to the flesh, to His mother, to the laws of life in the race at large, are so evidently and so deeply involved can possibly be a matter of indifference. The nature of His experience in the world, the quality and significance of His manhood, the fundamental constitution of His person, the nature and limits of the incarnation are necessarily and vitally concerned in the discussion. It is impossible to begin with the acceptance or rejection of the fact and arrive by logical processes at like convictions on any fundamental matter in the region of Christology.



All this must have been as patent to the earliest believers as to ourselves. The men who incorporated this incident into the gospel narrative could not possibly have been blind to the importance of what they were doing (cf Lk 1 3). In view of these facts it would be well for the serious student to ask himself this question: "On the hypothesis of invention, what manner of men were they who fabricated these narratives and succeeded in foisting them upon the church so early as to dominate its earliest official records and control the very making of all its creeds?" It is clear that deliberate invention is the only alternative to historical credit. We may throw out of court as altogether inadmissible the hypothesis that the church as a whole, by a naïve and semi-unconscious process, came to believe these stories and to accept them without criticism. Rumors always grow in the absence of known facts, esp. where curiosity is keen. Absurd rumors multiply among the credulous. But no statement contrary to natural expectation was ever yet promulgated among people of even average intelligence without meeting the resistance of incredulity on the part of some individuals who wish to inquire, esp. if means of verification are within reach. In this particular instance, the issue may be stated much more sharply. At no period reasonably to be assigned for the origin and incorporation of these documents could they have been honestly accepted by any member of the Christian community, sufficiently taught to occupy a position of authority. If the story was invented, there must have been a time when Jesus was universally accepted as the son by natural generation of Joseph and Mary. The story surely was not invented before His birth nor for some time after. The first person, therefore, who spoke contrary to the prevalent and natural belief must have had it from the family, which alone knew the truth, or else have been a wanton and lying gossip. Such a story is recognizable on the face of it as authoritative or pure invention. There is no middle ground. It could not have been recounted without being challenged for its strangeness and for its contradiction of the accepted belief. It could not have been challenged without the exposure of its groundless and fraudulent character, for the simple reason that the lack of positive and authoritative certification would be its immediate and sufficient condemnation. It is not difficult to draw the portrait of the inventor of this story. He must have been lacking, not only in the sense of truthfulness, but also in the elementary instinct of delicacy, to have invaded the privacy of the most sacred home known to him and deliberately invented a narrative which included the statement that Mary had come under suspicion of wrongdoing in such a way as to shadow the life of her Son. He must also have been doctrinally lax in the extreme, as well as temperamentally presumptuous, to have risked a mutilation of the truth by an invention dealing with such essential matters.

Moreover, this hypothesis demands that this fabrication must have met with instantaneous and universal success. It passed the scrutiny of the church at large and of its authorized teachers, and was never challenged save by a small group of heretics who disliked it on purely dogmatic grounds.

To whatever origin in the way of suggestion from without one may attribute the story—whether one may ascribe it to the influence of OT prophecy, or Jewish Messianic expectations in general, or to ethnic analogies, Bab. Egypt or Gr—the fact remains that the story had

to be invented and published by those who ought to have known better and could easily have known better had they possessed sufficient interest in the cause of truth to have made even casual inquiries into the credentials of such an important statement offered for their acceptance. It is fairly true to say that ethnic analogies for the birth of Christ fail (see art. on "Heathen Wonder-Births and the Birth of Christ," *Princeton Review*, January, 1908). It is also true that the rooted Sem conviction shared by the Hebrews, that family descent is to be traced through the male line only, so persistent even among the NT writers that both evangelists, on the face of them, trace the lineage of Joseph, would have acted as an effectual barrier against this particular legendary development. It is further true that no passage of the OT, including Isa 7 14, can be adduced as convincing evidence that the story was invented under the motive of finding fulfillment for Messianic predictions (see *IMMANUEL*). But far more satisfactory is the elementary conviction that the founders of the Christian church and the writers of its documents were not the kind of men to accept or circulate stories which they knew perfectly well would be used by unbelief in a malignant way to the discredit of their Master and His family. The hypothesis of invention not only leaves an ugly cloud of mystery over the birth of Jesus, but it discredits beyond repair every man who had to do with the writing and circulation of the Gospels, down to and including the man who professes to have "traced the course of all things accurately from the beginning," according to the testimony of those who were "eyewitnesses and ministers of the word" (Lk 1 2f). It is simply impossible to save the credit, in any matter involving honesty or common-sense, of one who uses words like these and yet incorporates unauthenticated legends into the narrative to which he has thus pledged himself.

One may venture at the close of this section of the discussion to point out that everything which the inventor of this story must have been, the narrators of it are not. Both narratives exhibit a profound reverence, a chaste and gracious reserve in the presence of a holy mystery, a simplicity, dignity and self-contained nobility of expression which are the visible marks of truth, if such there are anywhere in human writing.

**IV. The Critical Question.**—The infancy narratives evidently stand somewhat apart from the main body of apostolic testimony. The personal contact of the disciples with Virgin-Birth Jesus, upon which their testimony primarily rests, extended from the call of the disciples, near the opening of the ministry, to the resurrection and post-resurrection appearances. It is hyper-skepticism to deny that the substance of the gospel narrative rests upon the basis of actual experience. But all four evangelists show a disposition to supplement the immediate testimony of the disciples by the use of other well-attested materials. Luke's introductory paragraph, if it was written by an honest man, indicates that he at least was satisfied with nothing less than a careful scrutiny of original sources, viz. the testimony, written or oral, of eyewitnesses. It may reasonably be surmised that this was the general attitude of the entire group of apostles, evangelists and catechists who are responsible for the authorship and circulation of the Gospels.

But, to say nothing of the infancy narratives, for one of which Luke himself is responsible, these writers have embodied in the narrative the ministry of John the Baptist, the baptism and temptation of Jesus, all of which events happened before their fellowship with Jesus, strictly speaking, began. In particular, assuredly no disciple was an eyewitness of the temptation. None the less the narrative stands, simply because imaginative invention of such an incident in the absence of accredited facts cannot reasonably be considered. The fact that the birth narratives do not rest upon the testimony of the same eyewitnesses who stand for the ministry of Jesus does not discredit them as embodying reliable tradition, unless it can be proved that they contradict the rest of the apostolic testimony or that no reliable witness to the events in question was within reach at the time when the documents were composed. In the present instance such a contention is absurd. The very nature of the event points out the inevitable first-hand witnesses. There could be no others. In the absence of their decisive word, bald invention would be necessary. To charge the entire church of the time (for this is what the hypothesis amounts to) as *particeps*

*criminis* in its own official and documentary deception is an extreme position as unwarranted as it is cruel.

The internal harmony of the facts as recorded points in the same direction. The silence or comparative lack of emphasis with reference to the birth of Christ on the part of the other NT writers is to be explained partly on the basis of doctrinal viewpoint (see V, below) and partly because an ingrained sense of delicacy would naturally tend to reticence on this point, at least during the lifetime of Mary and the Lord's brethren. The following intimately corresponding facts are sufficiently significant in this connection: (1) that the fact of Jesus' unique birth could not be proclaimed as a part of His own teaching or as the basis of His incarnate life; (2) that He was popularly known as the son of Joseph; (3) that the foster-fatherhood of Joseph, as embodied in the genealogy (see GENEALOGY OF JESUS CHRIST), was the recognized basis of His relationship to the house of David. All these facts appear just as they should in the narrative. The very fact that the genealogies, ending with the name of Joseph, and the current representations of Jesus as Joseph's son, are allowed to appear in the same documents in which the virgin-birth statements appear, together with the entirely congruous facts that the main synoptic narrative does not emphasize the event, and that neither Paul nor John nor any other NT writer gives it a prominent place, is indication enough that it rested, in the opinion of the entire witnessing body, on a sufficient basis of evidence and required no artificial buttressing. Internal harmonies and incidental marks of truthfulness are of the utmost importance here because in a narrative so complex and vital it would have been easy to make a misstep. Since none was made, we are constrained to believe that the single eye to truth filled the apostolic mind with light. Every item, in the infancy narratives themselves, as well as in the more strictly doctrinal statements of other NT books, is as we should expect, provided the birth statement be accepted as true. Internal evidence of truthfulness could not be stronger.

This general conclusion is confirmed when we come to consider the relationship of the two narratives to each other. To begin with, we have two narratives, differing greatly in method of treatment, grouping of details, order and motive of narration, and general atmosphere. It is evident that we have two documents which have had quite a different history.

## 2. Inter-relationship of Narratives

In two points, at any rate, what might be considered serious discrepancies are discoverable (see DISCREPANCIES, BIBLICAL). These two points are: (1) the relationship of the Massacre of the Innocents and the journey to Egypt, as related by Matthew, to Luke's account, which carries the holy family directly back to Nazareth from Bethlehem after the presentation in the temple; (2) the discrepancy as to the previous residence at Nazareth (Lk) and the reason given for the return thither (Mt). As to (1) it is quite clear that Matthew's account centers about an episode interpolated, so to say, into the natural order of events (see INNOCENTS, MASSACRE OF THE). It is also clear that the order of Luke's narrative, which is in the highest degree condensed and synoptic, does not forbid the introduction of even a lengthy train of events into the midst of ver 39 (cf condensation in vs 40-42.51.52). It may easily be that the lacunae in each account are due to a lack of knowledge on the part of either writer as to the point supplied by the other. Matthew may not have known that the family had resided formerly in Nazareth, and Luke may not have known that a return to Galilee as a permanent residence was not contemplated in the original plan. The difficulty here is not serious. We consider the discrepancy as it stands as of more value to the account as indicating the independence of the two accounts and the honesty of those who incorporated them into the Gospels without attempting to harmonize them, than any hypothetical harmonization however satisfactory. We introduce this caveat, however, that Matthew had an especial reason for introducing the episode connected with Herod and for explaining the residence at Nazareth during Our Lord's early years

as occurring by Divine authority (see Sweet, *Birth and Infancy of Jesus Christ*, 218 f, for discussion of this point; and cf INNOCENTS, MASSACRE OF THE).

We are now free to consider the remarkable convergence of these two documents. The following particulars may be urged: (1) the synchronism in the Herodian era; (2) the name "Jesus" given by Divine authority before birth; (3) Davidic kinship; (4) the virgin-birth; (5) the birth at Bethlehem; (6) residence at Nazareth. In addition we may urge the essential and peculiar harmony of descriptive expressions (see V, below) and the correspondence of the inner and outer experiences of Mary (see MARY, II).

We have now reached the final and crucial point of this phase of our discussion when we take up the question as to the sources, origin and date of these narratives. Our method of approach to the general question of their credibility delivers us from the necessity of arguing *in extenso* the theories which have been framed to account for the narrative in the absence of historical fact. We resort to the simple and convincing principle that the story could not have been honestly composed nor honestly published as derived from any source other than the persons who could have guaranteed its trustworthiness. Every indication, of which the narratives are full, of honesty and intelligence on the part of the narrators is an argument against any and all theories which presuppose a fictitious origin for the central statement. Negatively, we may with confidence assert that wide excursions into ethnic mythology and folklore have failed to produce a single authentic parallel either in fact or in form to the infancy narratives. In addition to this, the attempt to deduce the story from Messianic prophecy also fails to justify itself. In addition, there are two considerations which may justly be urged as pointing to trustworthy sources for the narrative: First, the strongly Hebraic nature of both narratives. It has often been pointed out that nowhere in the NT do we find documents so deeply tinged with the Hebraic spirit (see Adeney, *Essays for the Times*, no. XI, 24 f; and Briggs, *New Lights on the Life of Christ*, 161 f). This statement involves both narratives and is another evidence of profound internal unity. A second important fact is that the doctrinal viewpoint is Jewish-Christian and undeveloped. The term "Holy Spirit" is used in the OT sense; the Christology is undeveloped, omitting reference to Christ's preexistence and interpreting His sonship as official and ethical rather than metaphysical. The soteriology is Jewish and Messianic, not unfolding the doctrine of the cross. All these facts point in one direction, namely, to the conclusion that these documents are early. It is impossible reasonably to suppose that such documents could have been composed in the absence of sources, or by persons devoid of the historical spirit, after the death and resurrection and ascension of Jesus had shed such light upon His person and mission as to transform both Christology and soteriology through the ideas of incarnation, atonement and the Trinity.

It is still asserted, in the face of the most convincing evidence to the contrary, that the infancy narratives are late addenda to the gospel tradition as a whole. This idea is due, primarily, to a confusion of thought between origin and publication. The latter must have been coincident with the original issue of the Gospels in their present form. The textual evidence here is convincing. On the other hand, the main body of testimony incorporated into the Gospels at the time of their publication had been in the hands of the apostles and their helpers for some years, as evidenced by the Pauline letters and the Book of Acts. In all probability the sources upon which the infancy narratives rest, which had their origin and received the impress which characterizes them in the period antecedent to the

public ministry of Jesus, came into the hands of the Gospel writers toward the end of the formative period at the close of which the Gospels were issued. In other words, the story of the Lord's birth was withheld until the time was ripe for its publication. Two occasions may have served to release it: the death of Mary may have made it possible to use her private memoirs, or the rise of anti-Christian calumny may have made the publication of the true history imperative. At any rate, the narratives show every indication of being contemporary documents of the period with which they deal. This fact puts an additional burden of proof, already heavier than they can bear, upon those who would antagonize the documents. We may reasonably affirm that the narratives will bear triumphantly any fair critical test.

**V. The Doctrinal Question.**—The discussion of the doctrinal significance of the virgin-birth statement falls naturally into three parts:

**1. In the NT** (1) its doctrinal elaboration in the NT; (2) its historic function in the development of Christian doctrine; (3) its permanent value to Christian thought. We begin with the narratives themselves. As has just been said, they were incorporated into the Gospels at a time when the NT Christology had reached maturity in the Pauline and Johannine writings and the Ep. to the He. The doctrine of the incarnation was fully unfolded. It had been unequivocally asserted that in Jesus all the fullness of the Godhead was historically and personally manifested (Jn 1 14; Phil 2 5-8; Col 1 18; 2 9; He 2 14). In contrast with these statements the infancy narratives not only, as adverted to above, exhibit on the surface a rudimentary Christology, but in several items, of profound interest and most surprising tenor, show that the birth notice was not apprehended or stated in view of the doctrine of the incarnation at all.

The detailed justification of this statement follows: (1) Matthew (see 1 18-25) does not use the term "Son of God." The only expression implying a unique relationship to God, other than in the "of Holy Spirit" phrase, twice used, is in the word "Immanuel," quoted from Isa, which does not necessarily involve incarnation. At the beginning of the genealogy Jesus is introduced as the son of David, the son of Abraham. (2) The assertion as to His conception by Holy Spirit is conditioned by three striking facts: (a) His conception is interpreted in terms of conception by the power of Holy Spirit, not of begetting by the Father. The OT expression "This day have I begotten thee," used twice, occurs in quite a different connection (He 1 5; 5 5). (b) The term "Holy Spirit" is used without the article. (c) The phrase descriptive of the being conceived is expressed in the neuter, "the thing conceived in her is of Holy Spirit" (τὸ γὰρ ἐν αὐτῇ γεννηθὲν ἐκ πνεύματος ἁγίου, τὸ γὰρ ἐν αὐτῇ γεννηθὲν ἐκ πνεύματος ἁγίου ἐστὶν ἁγίου). The implication of these three facts is (i) that the sonship of Jesus through His exceptional birth is interpreted in terms of Divine power working upon humanity, not as the correlative of Divine and essential fatherhood; it is the historical sonship that is in view (contrast with this the two passages in He referred to above); (ii) the writer is speaking in the OT sense of "Holy Spirit" as the forthcoming of creative power from God, not as personal hypostasis; (iii) he is also emphasizing (in the use of the neuter) the reality of the physical birth. These three facts, all the more remarkable because they are attributed to a heavenly messenger who might be expected to speak more fully concerning the mystery, exclude the supposition that we have one historic form of the doctrine of incarnation. On the contrary, had we no other statements than those found here we should be unable logically to postulate an incarnation. Every statement made concerning Jesus, apart from the virgin-birth statement itself, might be true were He the son of Joseph and Mary.

The case is far stronger when we turn to Luke's account, in spite of the fact that the terms "Son of the Most High" and "Son of God" ordinarily implying incarnation are used. We notice (d) that the anarthrous use of "Holy Spirit" reappears and that a poetic parallelism defines the term (ver 35), making "Holy Spirit" = "Power of the Most High"; (e) that the neuter phrase is also found here, "the holy thing which is begotten," etc (δὸ καὶ τὸ γεννηθὲν ἅγιον κληθήσεται, διὸ καὶ τὸ γεννηθὲν ἅγιον κληθήσεται); (f) that future tenses are used in connection with His career and the titles which He bears: "He shall be [as the outcome of a process] great," and "He shall be called [as a matter of ultimate titular recognition] the Son of the Most High" (ver 32); "The holy thing . . . shall be called the Son of God" (ver 35). In these instances the title is connected directly with the career rather than the birth.

Even the "wherefore" of ver 35, in connection with the future vb., carries the power of God manifested in the holy conception forward into the entire career of Jesus rather than bases the career upon the initial miracle. These three facts taken together exclude the reference to any conception of the incarnation. The incarnation is directly and inseparably connected with Christ's eternal sonship to the Father. The title "Son of God" includes that but does not specify it. It includes also the ethical, historical, human sonship. The term "Holy Spirit" used without the article also is a comprehensive expression covering both a work of Divine power in any sphere and a work of Divine grace in the personal sphere only.

These accounts are concerned with the historic fact rather than its metaphysical implications. This historic fact is interpreted in terms of a Divine power in and through the human career of Jesus. (which is so stated as to include an impersonal, germinal life) rather than a dogmatic definition of the Messiah's essential nature. The omission of all reference to preëxistence is negatively conclusive on this point. The Divine power manifested in His exceptional origin is thought of as extending on and including His entire career. This leads us directly to a second phase in the interpretation of Christ and compels to a reconsideration at a new angle of the miracle of His origin.

The narrators of the life and ministry of Jesus on the basis of ascertained fact and apostolic testimony were confronted with a very definite and delicate task. They had to tell with unexaggerating truthfulness the story of the human life of Jesus. Their ultimate aim was to justify the doctrine of incarnation, but they could not have been unaware that the genuine and sincere humanity of Christ was a pillar of the doctrine quite as much as His essential Deity. To portray the human experience of a being considered essentially Divine was the Herculean task attempted and carried to a successful issue in the Synoptic Gospels. These writers do not conceal for a moment their conviction that they are depicting the career of the wonder-working Son of God, but they never forget that it is a career of self-limitation within the human sphere, the period of self-imposed and complete humiliation undertaken on behalf of the Father, "for us men and for our salvation." Hence the nature and limitations of the narrative. Mark omits reference to the virgin-birth. Matthew and Luke narrate it and forthwith drop it. These facts are exactly on a par. It is no more remarkable that Mark omits the story than that Matthew and Luke make so little of it. To allege either fact as a motive to doubt is to misinterpret the whole situation. By the terms of their task they could do nothing else. The Fourth Gospel and the Epp. announce that the human life of Jesus was due to the voluntary extra-temporal act of a preëxistent Divine being, but in the synoptic narrative four passages only hint at preëxistence, and then as incidental flashes from the inner consciousness of Jesus. This omission is no more remarkable and no less so than the omissions noted above. By the terms of their task the synoptic writers could do nothing else. The fact of preëxistence could be announced only when the earthly task had been triumphantly finished (see Mk 9 9.11). During the entire period of the earthly life as such Jesus was under trial (note Mt 3 17, correctly translating the aorist; cf the remarkable words of Jn 10 17), performing a task, accomplishing a commission, achieving a victory as human son. The story of the Temptation exhibits the conditions under which Jesus performed His task. The temptations were one and all addressed to His consciousness as God's Son. They were resisted on the sole basis of self-humiliation and dependence. The entire synoptic narrative is consistent with this representation. Jesus is con-

sciously one in will and spirit with God, but that oneness with God is consummated and conducted in the Spirit, through faith, by prayer. They describe His entire career of holiness, wisdom and power, each unique, in the terms of the Spirit-filled, trustful, prayerful human life. Here is the vital point. They disclose the eternal Sonship (in which beyond question they believe) on its ethical, not on its metaphysical side, by prediction of His future triumph rather than by definition of His person. In such a narrative, consistently carried out, there can be no resort to the preëxistent, eternal Sonship, nor to the miracle of His human origin in the story of His career under trial. In particular, the miracle, whereby His germinal connection with the race was established could not extend to the personal and spiritual life in which His victory was His own through the personal Holy Spirit. The argument from the virgin-birth to His sinlessness (see *IMMACULATE CONCEPTION*) was made by the church, not by the NT writers. The sinlessness of Christ was His own achievement in the flesh which He sacrificed through His holy will of obedience to the Father.

This leads us to a third phase of development in the NT doctrine of incarnation. In the Fourth

Gospel and the Epp. it is asserted that  
**3. In Rest of the NT** the innermost moral significance of the earthly career of Jesus lay in the fact that it was the consistent carrying-out of an extra-temporal volition of Divine mercy and love whereby He became the Revealer of God and the Saviour of men. This doctrine is based upon the story of the human career completed in the glorification which, according to the testimony, ensued upon His death and disclosed His place in the Divine sphere of being. But it is also based upon the virgin-birth narrative and grounded in it. Attention has already been called to the fact that the virgin-birth is not (in the infancy narrative) connected with the metaphysical sonship of Jesus. All that is said then, doctrinally, concerning Jesus might be true were He the son of Joseph and Mary. On the contrary, what is said in Jn and the Epp. depends upon the virgin-birth narrative for its foundational basis. It has often been asserted that Paul and John do not refer to the virgin-birth. This statement the present writer takes to be more than doubtful, but if it is true, all the more striking is the indirect and unconscious testimony to the virgin-birth involved in their doctrinal reliance upon it. According to these writers the incarnation was due to a Divine act of self-limitation whereby the Divine mode of existence was exchanged for the human (Phil 2 5-11 et al.). According to the infancy narrative, the birth of Jesus was due to a *Divine creative act* whereby a human life began germinally and passed through the successive stages of growth to maturity. The synoptic narrative outside the infancy narrative supplies a third point, that the entire conscious personal career of Jesus upon earth was lived in the power of the Holy Spirit. The infancy narrative is the keystone of an arch, one half resting upon the synoptic account, the other upon the doctrinal construction of Jn and the Epp. The virgin-birth statement by its adoption of OT terminology makes room for a Divine activity both in the impersonal and in the personal spheres. The doctrine of incarnation implies that as in every new human being the creative Divine power manifests itself impersonally in germinal beginnings, so in the life of Christ the Divine power conditions itself within the impersonal forces of germinant life with this important and suggestive difference: In the career of Jesus there issues from the sphere of germinal beginnings not a new human person created from the life-stock of the race, but the personal human life, including all human powers,

of a preëxistent Divine person self-conditioned and self-implanted within the human sphere. The central conscious self, the agent of His activities and the subject of His experiences in the historic sphere was the eternal Son of God. His life in the human sphere was that of a true human being in the full actuality of a human life. Hence it follows, since ordinary generation involves *necessarily* (that is the intent of it) the origination of a new person not hitherto existing, that the birth of Jesus could not have been by ordinary generation. The birth of Christ through ordinary generation would have involved a quite incomprehensible miracle, namely, the presence and action of the ordinary factors in human origins with a contrary and unique result. The virgin-birth is the only key that fits the vacant space in the arch. In addition it may reasonably be urged that the relationship of human parents to each other, ordinarily a natural, necessary and sacred act, could have no part in this transaction, while the very fact that Mary's relationship was to God alone, in an act of submission involving complete self-renunciation and solitary enclosure within the Divine will, fulfils the spiritual conditions of this unique motherhood as no other imaginable experience could.

Historically the virgin-birth statement performed a function commensurate with the importance ascribed to it in this discussion rather

**4. Oppositions to the Doctrine** than the current depreciation of it. The doctrine of Christ was menaced in two opposite directions, which may be designated respectively by the terms "Ebionite" and "Gnostic." According to the former teaching (the word "Ebionite" being used in a general sense only), Jesus was reduced to the human category and interpreted as a Spirit-led man or prophet, in the OT meaning of the term. According to the opposite tendency, He was interpreted as Divine, while His human experience was reduced to mere appearance or a temporary external union with the Logos. The virgin-birth statement resisted both these tendencies with equal effectiveness. On the one hand, it asserted with unequivocal definiteness a real humanity conditioned by true birth into an actual connection with the race. On the other hand, it asserted an exceptional birth, setting Jesus apart as one whose entrance into the world was due to a new, creative contact of God with the race. Historically, it is difficult to see how the NT doctrine could have escaped mutilation apart from the statement, seemingly framed with express reference to conditions arising afterward, which so wonderfully guarded it. The holy mystery of the Lord's origin became the symbol of the holier mystery of His Divine nature. It thus appears in every one of the historic creeds, an assertion of fact around which the belief of the church crystallized into the faith which alone accounts for its history, a profound and immovable conviction that Jesus Christ was really incarnate Deity.

The importance for modern thinking of the virgin-birth statement is threefold: (1) First, it involves in general the question, never more vital than at the present time, of the trustworthiness of the gospel tradition. **Modern Thought** This particular fact, i.e. the virgin-birth, has been a favorite, because apparently a vulnerable, point of attack. But the presuppositions of the attack and the method according to which it has been conducted involve a general and radical undermining of confidence in the testimony of the gospel witnesses. This process has finally met its nemesis in the Christus-myth propaganda. The virgin-birth statement can be successfully assailed on no grounds which do not involve the whole witnessing body of

Christians in charges of blind credulity or wilful falsification, very unjust indeed as respects their character and standing in general, but very difficult to repel in view of the results of denial at this point.

(2) The virgin-birth is important for the simple historical reason that it involves or is involved in a clear and consistent account of the Lord's birth and early years. Apart from the infancy narratives we are utterly without direct information as to His birth, ancestry or early years. Apart from these narratives we have no information as to the marriage of Joseph and Mary; we are shut up to vague inferences as to this entire period. No biographer ever leaves these points obscure if he can avoid it. It is very earnestly suggested that those who cast discredit upon the infancy story do not clearly recognize the seriousness of the situation brought about in the absence of any narrative which can be trusted as to this vital point. Calumny there is and has been from an early day. If there is nowhere an authoritative answer to the calumny, in what sort of a position is the Christian believer placed? He can assert nothing, because apart from what he has too lightly thrown away he knows nothing.

(3) Lastly, the more closely the statement as to the Lord's birth is studied, the more clearly it will be seen that it involves in a most vital and central way the entire doctrine of the incarnation. This doctrine is an interpretation of facts. Those facts stand together. In the midst of those facts, harmonizing with them, shedding light upon them and receiving light from them, resting upon the same consentient testimony is the statement, which is thus worded in the oldest symbol of our historical faith: "Conceived by the Holy Ghost, Born of the Virgin Mary" (see APOSTLES' CREED). There is no adequate reason why the intelligent believer should feel uncertain as to this statement of our holy religion.

LITERATURE.—There is a vast and growing literature which more or less directly deals with the subject of Our Lord's birth. The literature may be classified as follows: (1) Lives of Christ; (2) critical comms. on Mt and Lk; (3) critical and historical investigations of Christian origins; (4) monographs on the Apostles' Creed; (5) monographs and arts. on the specific subject. For a list and analysis of discussions see Sweet, *Birth and Infancy of Jesus Christ*, 354-57.

LOUIS MATTHEWS SWEET

**VIRTUE**, vîr'tū: This word has two quite distinct meanings in AV: (1) It was formerly often used in the now obsolete sense of "manly power," "valor," "efficacy" (Lat *virtus*, "manly strength" or "excellence," from *vir*, "man"):

"Trust in thy single *virtue*; for thy soldiers  
All levied in thy name, have in thy name  
Took their discharge."

—Shakespeare, *King Lear*, V, iii, 103 ff.

It was also used in the sense of a mighty work, a miracle. Thus Wycliffe translates Mt 11 20: "Thanne Jhesus bigan to saye preef to cities in whiche ful many *vertues* of him weren don." So in AV Mk 5 30; Lk 6 19; 8 46, in the sense of "power," "miraculous energy or influence" (*δύναμις*, *dynamis*, "inherent power, residing in the nature of a thing"; contrast *ἐξουσία*, *exousia*, "power arising from external opportunity or liberty of action"). In these passages it is tr'd in RV "power" (as elsewhere in AV; cf Acts 3 12, etc.). (2) In its ordinary modern meaning of "moral goodness" it occurs in AV and RV Wisd 4 1; 5 13; 8 7; Phil 4 8; 2 Pet 1 3.5. In these passages it stands for *ἀρετή*, *aretē*, the usual classical term for "moral excellence" (originally "fitness" of any sort), used in LXX to translate words meaning "glory," "praiseworthiness," as in Hab 3 3; Isa 42 12; 63 7 (of God); Zec 6 13 (of the Messiah). The LXX sense may color the meaning of the word as applied to God

in 2 Pet 1 3 RV; as also in its pl. use (of God) in I Pet 2 9 (AV "praises," RV "excellencies").

The adj. "virtuous" occurs in AV, ERV Ruth 3 11; Prov 12 4; 31 10 (ARV "worthy"), and the advb. "virtuously" in Prov 31 29 (ARV "worthily"), in each case for *הַיָּל*, *hayil*, "strength," "force" (whether of body or of mind), then in a moral sense of "worth," "virtue." D. MIALL EDWARDS

**VISION**, vizh'un (וִיזוֹן, *hāzōn*, וִיזוֹן, *hizyāyōn*, מַרְאֵה, *mar'āh*; ὄραμα, *hōrama*, ὀπτασία, *optasia*):

Psychologists find that man is prevailingly and persistently "eye-minded." That is, in his waking life he is likely to think, imagine and remember in terms of vision. Naturally then, his dreaming is predominantly visual; so strongly visual, we are told, that it is not rare to find dreams defined as "trains of fantastic images." Whether man was made this way in order that God might communicate with him through dreams and visions is hardly worth debating; if the records of human life, in the Bible and out of it, are to be trusted at all, there is nothing better certified than that God has communicated with man in this way (Ps 89 19; Prov 29 18; cf Am 8 11.12; Hos 12 10). If one is disposed to regard the method as suited only to primitive peoples and superstitious natures, it still remains true that the experience is one associated with lives and characters of the most saintly and exalted kind (I S 3 1; Jer 1 11; Ezk 1 1; Dnl 2 19; Acts 9 10; 10 3; 16 9).

The vision may come in one's waking moments (Dnl 10 7; Acts 9 7); by day (Cornelius, Acts 10 3; Peter, Acts 10 9 ff; cf Nu 24 4.16) or night (Jacob, Gen 46 2); but commonly under conditions of dreaming (Nu 12 6; Job 4 13; Dnl 4 9). The objects of vision, diverse and in some instances strange as they are, have usually their points of contact with experiences of the daily life. Thus Isaiah's vision of the seraphim (6 2) was doubtless suggested by familiar figures used in the decoration of the temple at Jerus; Paul's "man of Macedonia" (Acts 16 9) had its origin in some poor helot whom Paul had seen on the streets of Troas and who embodied for him the pitiful misery of the regions across the sea; and "Jacob's ladder" (Gen 28 12) was but a fanciful development of the terraced land which he saw sun-glorified before him as he went to sleep. Among the recurring objects of vision are natural objects—rivers, mountains, trees, animals—with which man has daily and hourly association.

The character of the revelation through vision has a double aspect in the Bib. narrative. In one aspect it proposes a revelation for immediate direction, as in the case of Abram (Gen 15 2 and frequently); Lot (Gen 19 15); Balaam (Nu 22 22), and Peter (Acts 12 7). In another aspect it deals with the development of the Kingdom of God as conditioned by the moral ideals of the people; such are the prophetic visions of Isaiah, Ezekiel, Hosea, and Micah, and the apocalypses of Daniel and John. The revelation for immediate direction has many correspondences in the life of the devout in all ages; the prophetic vision, dealing in a penetrating way with the sources of national growth and decay, has its nearest approach in the deliverances of publicists and statesmen who are persuaded that the laws of God, as expressed in self-control, truth, justice, and brotherly love, are supreme, and that the nations which disregard them are marked for ultimate and speedy extinction.

From the nature of the vision as an instrument of Divine communication, the seeing of visions is naturally associated with revivals of religion (Ezk 12 21-25; Joel 2 28; cf Acts 2 17), and the ab-

sense of visions with spiritual decline (Isa 29 11. 12; Lam 2 9; Ezk 7 26; Mic 3 6).

One may see visions without being visionary in the bad sense of that word. The outstanding characters to whom visions were vouchsafed in the history of Israel—Abraham, Moses, Jacob, David, Isaiah, Jesus and Paul—were all men of action as well as sentiment, and it is manifest from any fair reading of their lives that their work was helped and not hindered by this aspect of their fellowship with God. For always the vision emphasizes the play of a spiritual world; the response of a man's spirit to the appeal of that world; and the ordering of both worlds by an intelligent and compelling Power able to communicate Himself to man and apparently supremely interested in the welfare of man.  
CHARLES M. STUART

**VISITATION**, viz-i-tā'shun, vis- (ⲃⲓⲧⲓⲧⲓⲟⲛ, *p'kud-dāh*; ἐπισκοπή, *episkopē*): In Bib. writings, the Divine investigation or inspection of men's character and deeds with a view to apportioning to them their due lot, whether of reward or of chastisement; Divine dispensation of mercy or of punishment. (1) In a general sense: "Visited after the visitation of all men" (Nu 16 29), i.e. in natural death, the usual lot of men, as opposed to a calamitous death; "She shall have fruit in the visitation of souls" (Wisd 3 13 AV), i.e. in the time of Divine judgment. So Sir 18 20 and perhaps 1 Pet 2 12. (2) In a good sense, of God's care, providence and mercy: "Thy visitation [RVm "care"] hath preserved my spirit" (Job 10 12). So Lk 19 44, and, according to some, 1 Pet 2 12 (see above). (3) Most frequently in an evil sense, of calamity or distress viewed as Divine punishment: "What will ye do in the day of visitation, and in the desolation which shall come from far?" (Isa 10 3). So Jer 8 12; 10 15; 11 23; 23 12; 46 21; 48 44; 50 27; 51 18; Hos 9 7; Mic 7 4; Wisd 14 11.  
D. MALL EDWARDS

**VOCATION**, vō-kā'shun. See CALLING.

**VOICE**, vois. See BATH KOL.

**VOID**, void: The uses of "void" in EV are all modern, except for the phrase "void place" in AV 1 K 22 10 || 2 Ch 18 9 (RV "open"); 2 Macc 14 44 (so AV and RVm). On the OT passages see OPEN PLACE. In 2 Macc the Gr word is κενών, *keneōn*, which may mean either "an open place," in general, or, specifically, "the hollow between the ribs and the hip," whence RV "his side." Moffatt in Charles' *Apoc* translates "the open street."

**VOLUME**, vol'ūm: This word (from Lat *volvere*, "roll"), twice used in AV (Ps 40 7 [Heb *m'ghillāh*]; He 10 7), is better Englished as "roll" in RV. See ROLL.

**VOLUNTARY**, vol'un-tā-ri: For the sake of variety AV in Lev 7 16; Ezk 46 12 (*bis*) has rendered ⲃⲓⲧⲓⲧⲓⲟⲛ, *n'dhābhāh*, by "voluntary offering" instead of the usual "freewill offering" (so RV). The words "of his own voluntary will" in Lev 1 3 AV are a pure gloss, properly omitted in RV, as they represent nothing in the Heb. 1 Macc 2 42 has "voluntarily" as part of the tr of ἐκουσιάζω, *hekousiázō*, RV "willingly."

**VOPHSI**, vof'si (ⲃⲟⲫⲥⲓ), *wophšē*, meaning unknown): Father of Nahbi the Naphtalite spy (Nu 13 14); but the text is doubtful. LXX B has 'Iaβel, *Iabēl*, A F Luc., 'Iaβl, *Iabēl*.

**VOW**, vou (ⲃⲟⲩ, *nedher*; εὐχή, *euchē*; ἱσῶς, *i'sšār*, found only in Nu 30 6.8.10 and tr<sup>d</sup> ὀρισμός,

*horismós*, by LXX): A vow could be positive (*nedher*) and included all promises to perform certain things for, or bring certain offerings to, God, in return for certain benefits which were hoped for at His hand (Gen 28 20-22, Jacob; Lev 27 2.8; Nu 30; Jgs 11 30, Jephthah; 1 S 1 11, Hannah; 2 S 15 8, Absalom; Jon 1 16, vows of heathen); or negative (*i'sšār*), and included promises by which a person bound himself or herself to abstain from certain things (Nu 30 3). Nowhere in the OT do we find the making of vows regarded as a religious duty (Dt 23 22), but the fulfilling of a vow was considered as a sacred and binding duty (Dt 23 21-23; Jgs 11 35; Eccl 5 4; of Ps 22 25; 66 13; 76 11; 116 18). A vow was as binding as an oath (see OATH) and therefore to be kept to the letter; and it was not to be lightly made (Prov 20 25). A father could veto a daughter's vow, and a husband a wife's. If a husband did not veto a wife's vow, and then caused her to break it, the sin was his and not hers (Nu 30, *passim*). It seems that vows were considered binding only when actually uttered (Dt 23 23). Persons, including one's self, animals, land and other possessions, could be vowed, but all these could be redeemed with money (see JEPHTHAH), which money was to be estimated by the priest, except in the case of a clean animal. In the case of land, houses and unclean animals a fifth part of the estimated value was to be added to make up the redemption money. In the case of land the sum was greater or smaller as the coming year of Jubilee was far off or near (Lev 27, *passim*). Nothing which was by nature holy could be made the object of a vow, e.g. firstlings, tithes, etc (Lev 27 26.28.30); and, on the other hand, an abomination, e.g. the hire of a prostitute, could not be made the object of a vow (Dt 23 18). In Mal 1 14 the offering of what was of less value than what had been vowed is vigorously condemned.

In the NT Jesus refers to vows only to condemn the abuse of them (Mt 15 4-6; Mk 7 10-13; of Talm, *N'dhārim*, and see CORBAN). In Acts 18 18 (cf Acts 21 23.24) Paul desires to show his Jewish brethren that he is willing to keep the forms of Jewish piety so long as they do not clash with his Christian conscience (cf 1 Cor 9 21). For the vow of the Nazirite, see NAZIRITE.

PAUL LEVERTOFF  
**VOYAGE**, voi'āj, AND SHIPWRECK, ship'rek, OF ST. PAUL. See PAUL THE APOSTLE; PHOENIX; and "Literature" to SHIPS AND BOATS.

**VULGATE**, vul'gāt:

- I. NAME AND ITS HISTORY
  1. Present Usage
  2. Earlier Usage
  3. Post-Hieronymic
  4. Historical Importance of the Vulgate
- II. ORIGIN
  1. Corruption and Confusion of Old Versions
  2. Heresy
  3. Inevitable Separation of East and West
  4. Request of Pope Damasus
- III. JEROME'S TRANSLATIONS AND REVISIONS: METHOD
  1. The NT
    - Gospels or Whole NT?
    - OT from the LXX
    - OT from the Hebrew
- IV. SUBSEQUENT REVISIONS AND HISTORY OF VULGATE
  1. In the MSS
  2. Printed Vulgate
- V. MSS OF VULGATE
- VI. LATINITY
- VII. USE OF VULGATE
- VIII. DIFFERENCES BETWEEN VULGATE AND ENGLISH VERSIONS

LITERATURE

**I. Name and Its History.**—The term "Vulgate" with us means but one thing—the standard authoritative Bible of the Lat or Rom church, prepared mostly by the labors of Jerome. But this is not

the original use of the word and it was never so used by Jerome himself; indeed, it did not at first refer to a Lat VS or tr at all. The word

**1. Present Usage** "Vulgate" comes from the adj. or participle *vulgata* which usually accompanied *editio*, and meant at first *current* or regularly used text. It was originally used as the equivalent of *κοινή ἔκδοσις*, *koinē êkdosis* = the LXX.

**2. Earlier Usage** Jerome and Augustine both use the term in this sense. Jerome (*Comm. in Isa* 65 20), "Hoc juxta LXX interpretis diximus, quorum editio toto orbe vulgata est" (and ib 30 22), *vulgata editio* again refers to the LXX. Elsewhere Jerome actually gives the Greek words (of the LXX) as found in *editio vulgata* (*Comm. in Osee* 7 13). Augustine identifies the expression with the LXX (*De doctr. christ.*, xvi.10): "Secundum vulgatam editionem, hoc est interpretum Septuaginta." The term *editio vulgata* was next extended to the form in which the LXX was at first known to the West—the Old Lat VSS (see LATIN; LATIN VERSIONS), although, as Westcott remarks, there does not appear to be any instance in the age of Jerome of the application of the term to the Lat VS of the OT without regard to its derivation from the LXX or to that of the NT, so that Jerome usually intended the LXX though he quoted it in Lat form. *Vulgata editio*, having acquired the meaning of the *current* or ordinarily used text of LXX, was once again extended to mean a corrupt or uncorrected text as opposed to the standard emended LXX VS of Origen's Hexapla, and in this sense is used by Jerome as synonymous with *antiqua* or *vetus editio*.

*Ep.*, cvi.2 deserves citing in this connection: "Admoneo aliam esse editionem quam Origenes et Caesariensis Eusebius omnesque Graeciae translatores κοινή [koinē], i.e. communem appellant atque vulgatam, et a plerisque Λουκιανός, [Loukianós] nunc dicitur: aliam LXX interpretum quae in Ἑξαπλότοις [Hexaplotis] [i.e. of Origen] codicibus reperitur, et a nobis in Latinum sermonem fideliter versa . . . κοινή [koinē] [communis editio] . . . vetus corrupta editio est, ea autem quae habetur in Ἑξαπλότοις [Hexaplotis] et quam nos vertimus, ipsa est quae in eruditorum libris incorrupta et immaculata LXX interpretum translatio reservatur." ("I recall that one is the text which Origen and Eusebius of Caesarea and all the Greek translators call the κοινή [koinē], i.e. the common and current text, and is now called by most persons Lucian's [version]; the other is the text of the translators of the LXX which is found in the codices [or books] of Origen [or the Hexapla], and has been faithfully translated by us into the Latin language . . . the koinē [the ordinary text] . . . is the old corrupted text, but that which is found in the Hexapla, and which we are translating, is the same one which the version of the translators of the LXX has preserved unchanged and immaculate in the books of the scholars.")

It was only very slowly that Jerome's VS acquired this name, the phrase *editio vulgata* being applied to the LXX or the Old Lat VSS of the LXX sometimes down to mediaeval

**3. Post-Hieronymic** times, while Jerome's tr was known as *editio nostra*, *codices nostri*, *tr emendatior*, or *tr quam tenet Rom ecclesia*. The Tridentine Fathers were therefore guilty of an anachronism when they referred to Jerome's tr as *vetus et vulgata editio*. Roger Bacon was apparently the first, in the 13th cent., to apply the term *Vulgata* in our sense (not exclusively, but also to the LXX), and this usage became classic through its acceptance by the Tridentine Council ("*vetus et vulgata editio*").

The interest of the Vulg will be apparent when we reflect that this tr proved to be to the West what the LXX had been to the East, that

**4. Historical Importance of the Vulgate** it was prepared with great care by the greatest scholar whom Lat Christianity produced, that it was for hundreds of years the only Bible in universal use in Europe, that it has given to us much of our modern theological terminology as well as being the sponsor for many Gr words which have enriched our conceptions. It

has also proved of primary importance as an early and excellent witness to the sacred text. Add to this that "directly or indirectly it is the real parent of all the vernacular VSS of Western Europe" except the Gothic of Ulfilas. For Eng.-speaking students it possesses peculiar interest as the source of the earlier tr<sup>s</sup> made by the Venerable Bede, and portions of the OT were tr<sup>d</sup> in the 10th cent. from the Vulg by Ælfric. Its greatest influence was exerted in the Eng. VS of Wycliffe—a literal tr from the Vulg (1383). And Coverdale's Bible (1535) was "faithfully and truly tr<sup>d</sup> out of Dutch [i.e. German of Luther] and Latin." The Rheims and Douay VS was based on the Vulg, though "diligently conferred with the Heb and Gr." The Vulg exercised considerable influence upon Luther's VS and through it upon our AV.

**II. Origin of the Vulgate.**—Lat Christianity had not been without a Bible in its own language. Old

**1. Corruption and Confusion of Old Versions** Lat VSS are found in North Africa as early as the middle of the 3d cent. and are found in the texts of Cyprian and Tertullian. But these tr<sup>s</sup> were characterized by "simplicity," "rudeness" and provincialism. There was not one standard authoritative VS with

any ecclesiastical recognition. VSS were rather due to "individual and successive efforts." Augustine says that anyone who got hold of a Gr MS and thought he knew Gr and Lat would venture on a tr. These VSS originated in Africa and not from Rome, else they had been more authoritative. Besides, the first two centuries of the Rom church were rather Gr; the earliest Christian literature of Rome is Gr, its bishops bear Gr names, its earliest liturgy was Gr. When the church of Italy became Lat-speaking—probably at the end of the 3d cent.—the provincialisms of the African VS rendered it unfit for the more polished Romans, and so recensions were called for. Scholars now recognize a European type of Old Lat text. And Westcott thinks a North Italian recension (at least in the Gospels) was made in the 4th cent. and known as the *Itala* (see LATIN), and which he recognizes in the *Itala* mentioned in Aug., *De doctr. christ.*, xv, as "verborum tenacior cum perspicuitate sententiae"; but F. C. Burkitt (*The Old Lat and the Itala*, 54 ff) takes the *Itala* here as referring to Jerome's VS. Amid such confusion and the appearance of national or provincial recensions, the Lat church became conscious of the need of a standard ed. There were almost as many types of texts as there were MSS: "Tot exemplaria paene quot codices," says Jerome (*Pref. to Gospels*). Independent and unauthorized or anonymous tr<sup>s</sup>—esp. of the NT—aided by the gross carelessness of scribes, made confusion worse founded. Augustine complains of this "Latinorum interpretum infinita varietas."

In addition to the inconvenience in preaching and the liturgical variations, a greater demand for an authoritative VS arose from the

**2. Heresy** continual watch of the early church against heretics. Confusion of text abetted heresy, and the absence of a standard text made it harder to refute it. Besides, the Jews, with one authoritative text, laughed at the confusion of the Christian Scriptures.

The inevitable separation of East and West, both politically and ecclesiastically, and the split between

**3. Inevitable Separation of East and West** Gr and Lat Christianity, rendered the existence of a standard Lat text imperative. Christianity was felt to be the religion of a book, and hence that book must be inspired and authoritative in every word—even in its order of words.

Pope Damasus determined to remedy this state

of affairs, and with all the authority of the papal see commissioned Jerome to produce an authentic and standard authorized VS.

**4. Request of Damasus** The pope's choice could not have fallen upon a more competent scholar—a man who had been providentially gifted and prepared for the task. Jerome—his Lat name was Eusebius Hieronymus—was born at Stridon on the borders of Dalmatia about 340, or a little later, of Christian parentage. He had the advantages of the best classical education and became a devoted student of the best Lat writers. In a dream he saw a vision of judgment, and on claiming to be a Christian he was rebuked: "Mentiris, Ciceronianus es, non Christianus." He began his theological studies in Gaul; but later sought the seclusion of ascetic life in the desert near Antioch. Here he studied Heb from a converted rabbi in order to subdue fierce passions by the difficulties of that language. About 375 or 376 began his correspondence with Damasus. In 382 he came to Rome, and became the intimate friend and adviser of Damasus.

**III. Jerome's Translations and Revisions: Method.**—These fall into three main groups: (1) revision of the NT; (2) OT juxta LXX;

**1. The NT** (3) OT from Heb. The exact date of the pope's commission is not given: it was probably in 382—the year of Jerome's arrival in Rome—or early in 383, in which year the Gospels appeared in revised form. Damasus asked simply for a revision of the Old Lat VSS by the help of the Gr rather than a new VS. Jerome collated Gr MSS, and carefully compared them with the "Italian" type of Old Lat texts; where possible the Old Lat was preserved. Thus Jerome approached the task with a conservative spirit. Still the result was a considerable departure from the Old Lat VS, the changes being (1) linguistic, removal of provincialisms and rudeness, (2) in interpretation, e.g. *supersubstantialis* for *ἐπιούσιον*, *epiούσιον*, in the Lord's Prayer, (3) the removal of interpolations, (4) the insertion of the Eusebian Canons.

*The Gospels or the whole NT revised?*—It is disputed whether Jerome revised the whole NT or only the Gospels.

Against the revision of the whole NT the arguments briefly are: (1) That Augustine, writing 20 years after the appearance of the revised Gospels, speaks only of "Gospel": "Evangelium ex Graeco interpretatus est" (*Ep.*, civ.6); but Augustine may here be speaking generally or applying "Gospel" to the whole NT. (2) Jerome in his preface apparently speaks of "only four Gospels" ("quattuor tantum evangelia"). (3) The rest of the NT does not show the same signs of revision as the Gospels. (4) The absence of the prefaces usual ("solita praefatione") to Jerome's revised VSS. On the other hand, to more than counterbalance these, (1) Damasus required a revision of the whole NT, not only of the Gospels (*Pref. of Damasus*). (2) In other statements of Jerome he expressly says he revised the NT (not Gospel or Gospels); in *Ep.*, cxii.20, he seems to correct Augustine's *evangelium* by writing: "Si me, ut dicit, in *Novi Testamenti emendatione* suspicis," and in *Ep.*, lxxi.5: "I translated the NT according to the Gr" ("NT Graecae reddidi auctoritati"); cf also *De Vir.*, III., cxxxv. (3) Jerome quotes passages outside the Gospels where his VS differed from the Old Lat VSS, e.g. Rom 12 11; Tim 1 15; cf *Ep.*, xxvii. (4) Damasus died at the end of 384—perhaps before the rest of Jerome's revision was published, and so Jerome thought no further prefaces needed.

The more likely conclusion is that Jerome revised the whole NT, though not all with equal care.

His revision was hasty and soon became more or less confused with the **2. OT Juxta LXX** Old Lat VSS to which the people clung as they do to all old VSS. Having probably completed the NT from the Gr, Jerome began immediately on the OT from the Gr of the LXX.

(1) *Roman Psalter*.—He commenced with the Pss, which he simply emended only where imperatively required (cf preface), and cursorily (c 384). This revision is called the Rom Psalter (*Psalterium Romanum*), which continued in use in Rome and Italy till it was displaced under the pontificate of Pius V by the Gallican Psalter, though the Rom

Psalter is still used in St. Peter's, Rome, and in St. Mark's, Milan.

(2) *Gallican Psalter*.—This Psalter soon became so corrupted by the Old Lat VS that Jerome (c 387) undertook a second revision at the request of Paula and Eustochium. This became known as the Gallican Psalter because of its early popularity in Gaul. It was also made from the LXX, but with the aid of other Gr VSS. Jerome adopted in it the critical signs used by Origen—a passage inclosed between an obelus and two points being absent from the Heb but present in the LXX, that between an asterisk and two points being absent from the LXX but supplied from Theodotion (*Preface to Pss*).

(3) *Rest of the OT*.—About the same time Jerome published tr<sup>s</sup> of other OT books from the LXX. Job was revised very soon after the Gallican Psalter. The preface to Prov, Eccl, Cant and Ch is extant to show he had revised these books. Job and Pss are the only books of this revision juxta LXX extant.

It is again disputed whether Jerome completed the whole OT in this revision because (1) the usual prefaces are again lacking (except to the books already mentioned), and (2) in his prefaces to the revision from the Heb Jerome makes no reference to an earlier revision of his own; (3) the work implied was too great for the brief space possible and must have been done between 387 and 390 (or 391), for by this latter date he was already on the tr from the Heb. But Jerome was a phenomenal worker, as we learn that his tr of Prov, Eccl and Cant from the Heb was made in three days. And his commentary on Eph was written at the rate of 1,000 lines a day.

Jerome probably completed the whole, as we infer from his own direct positive statements. He speaks of "mea in *libris canonicis* interpretatio" (*Ep.*, cxii. 19; see references in Westcott), and in the preface to the *Books of Solomon after the LXX* he states he did not correct Wisd and Ecclus, "desiring only to emend the canonical books" ("tantummodo canonicas scripturas vobis emendare desideraus"). Once again, he speaks of having carefully tr<sup>d</sup> the LXX into Lat (*Con Ruf.*, ii.24; cf *Ep.*, lxxi).

If the postscript to *Ep.*, cxxxiv, to Augustine is genuine, Jerome complains he had lost the most of his former labors by fraud ("pleraque enim prioris laboris fraude cuiusdam amisimus"). And Augustine requests from **3. Translation of OT** (*Ep.*, xcvi.34) from Jerome his VSS **Hebrew** from the LXX ("Nobis mittas, obsecro, *interpretationem tuam de LXX quam te edidisse nesciebam*").

In the course of these labors discovered the unsatisfactory condition of the LXX text and his friends pleading the need of a tr direct from the Heb, Jerome began this huge task about 390 with S and K, which he published with the *Prologus galeatus* ("helmeted prologue"), next the Pss (c 392), Job and the Prophets (393), 1 and 2 Esd (c 394) (3 and 4 being omitted), Ch (396). Then followed a severe illness until 398, when "post longam aegrotationem" he tr<sup>d</sup> Prov, Eccl and Cant. He then started on the Octateuch: "Octateucho quem nunc in manibus habeo" (*Ep.*, lxxi.5), the Pent being first tr<sup>d</sup> in 401, Josh, Jgs, Ruth and Est soon after (xl.4: "post sanctae Paulae dormitionem"). Tob and Jth were tr<sup>d</sup> for him from Chaldee into Heb from which he then tr<sup>d</sup> them into Lat (c 405), and shortly before or after these he added the apocryphal additions to Dul and Est. Bar he passed over. Wisd and Ecclus were not revised by him. Whether he revised Macc is doubtful. Thus was completed in 15 strenuous years (390–405) a work which has proved a *κτῆμα ἐς αἰῶνα*, *κτήμα ἐς αἰῶνα* (Thuc. i.22), "a possession for all time." The tr was largely undertaken at the request of friends and at no papal request. Indeed Jerome did not pretend to be working for publicity; he actually asked one friend not to show his tr.



*Reception.*—But human nature rarely recognizes merit in its own generation, and the spirit of conservatism rose in rebellion against beneficial innovation. Jerome was accused of slighting the LXX, which even in the eyes of Augustine was equally inspired with the Heb original. Jerome's fiery temper and his biting tongue were not calculated to conciliate.

#### IV. Subsequent Recensions and History of the Vulgate.

By degrees the fierce opposition died down, and even by the time of Jerome's death men were beginning to perceive the merits of his VS which Augustine used in the Gospels. Some parts of Jerome's Vulg won their way to popularity much sooner than others—the Old Lat VSS died hard and not without inflicting many a wound on the Vulg. His Psalter from the Heb never ousted the Gallican which still holds its place in the Vulg. Some scholars were able to appreciate Jerome's ed sooner than others. And it was at different dates that the different provinces and countries of the West adopted it. Pelagius used it in his comm. on the Pauline Epp. As might be expected, the Old Lat VSS retained their place longest in the place of their origin—North Africa. Britain proved the next most conservative. The old VSS were never authoritatively deposed, and so Jerome's VS was compelled to win its way by its own merits. In the 5th cent.—esp. in Gaul—it continued to grow in popularity among scholars, being adopted by Vincent of Lérins, Eucherius of Lyons, Sedulius, and Claudianus Mamertus, and Prosper of Aquitaine. In the next century its use became almost universal except in Africa, where the Old Lat was retained by Junilius and Facundus. At the close of the 6th cent. Pope Gregory the Great acknowledges that the new (i.e. the Vulg) and the old are both equally used by the Apostolic See; and thus the Vulg was at least on equal footing with the old. In the 7th cent. the Old Lat retreats, but traces of it survive down into the Middle Ages, affecting and corrupting the Jerome VS. Mixed texts and conflated readings arose—the familiarity of the Old Lat in lectionaries and liturgies telling on the Vulg. The NT, being only a revision and not a fresh tr, and being most in use, degenerated most.

(1) As early as the 6th cent. the need of an emended Vulg text was felt, and Cassidorus undertook to revise part of it. This was merely private enterprise and did little to stem the flood of corruption.

(2) About the close of the 8th cent. Charlemagne commissioned an Englishman Alcuin, abbot of St. Martin, Tours, to produce a revised text on the basis of the best Lat MSS, without reference to the Gr text. Alcuin sent to York for his MSS and thus produced a text after British MSS. On Christmas Day, 801 AD, he presented the emperor with the emended text. The authority by which this text was prepared and its public use together with the class of MSS used did much to preserve a pure Vulg text and stay interpolations: "The best MSS of his recension do not differ widely from the pure Hieronymian text" (Westcott).

(3) Another recension of about the same date—but a scholar's private enterprise—was produced by a Visigoth, Theodulf, bishop of Orleans. He made the Spanish family of MSS together with those of Southern France the basis of his text. His inscribing variant readings in the margin really helped the process of corruption. His text—though prepared at enormous labor—was far inferior to that of Alcuin and exerted little influence in face of the authoritative VS of Alcuin. MSS were rapidly multiplied in the 9th cent. on the Alcuinian model by the school of Tours, but with carelessness and haste which helped to a speedy degeneration of the text. Again the confusion called for remedy.

(4) In the 11th cent. Lanfranc, bishop of Canterbury (1069–89), attempted correction—apparently with little

success. About the middle of the 12th cent., Stephen Harding of Cîteaux produced a revision—extant in MS in Dijon public library (no. 9), as did also Cardinal Nicolaus. The increased demand for Bibles in the 13th cent. gave opportunity for further corruption of the text—publishers and copyists being indifferent as to the character of MS chosen as a basis.

(5) In consequence of the fame of the University of Paris in the 13th cent. and the enormous activity in producing Bible MSS, there resulted a type of text called by Roger Bacon *Exemplar Parisiense*, for which he has nothing good to say.

(6) In the same century steps were taken toward a standard text and to stay corruption by the drawing up of *correctoria*, i.e. books in which the readings of Gr and Lat MSS were weighed to decide a text, the authority of Fathers cited, etc. Some of the principal *correctoria* are: *Correctorium Parisiense* known also as *Senonense*—one of the worst, following the Parisian type of text; *Correctorium Vaticanum*, the best; *Correctorium Sorbonicum*, in the Sorbonne; *Correctorium Dominicanum*.

(1) *Early editions.*—Little more was done till the invention of printing, and the first products of the press were Lat Bibles. Unfortunately at first the current text was accepted without any critical labors, and so the earliest printed Vulgates only perpetuated an inferior text. Only a few from among some hundreds of early VSS can be noted:

(a) the Mazarin Bible—one of the most beautiful and valuable books in the world—printed at Mainz about the middle of the 15th cent. (1455, Westcott) by Gutenberg, Schöffer or Fust; (b) the first Bible published at Rome in 1471 by Sweynheym and Pannartz and reprinted in Nuremberg in 1475; (c) 1504 a Paris ed with variant readings; (d) an ed in Complutensian Polyglot (1514 ff) from ancient MSS and from the Gr; (e) practically the first critical ed, by Robertus Stephanus (1st ed 1528, 2d 1532, reprinted later), of interest as being practically the basis of the standard Rom Vulg; (f) Hentenian critical ed (Louvain, 1547). Attempts to produce a corrected text by aid of the original were made by Erasmus in 1516, Pagninus in 1518 ff, Cardinal Cajetan, Steuchius in 1529, Clarius in 1542, etc. Even new tr<sup>s</sup> were made by both Roman Catholic and Protestant scholars. This bewildering number of VSS and the controversies of the 16th cent. called for a standard ed. The Council of Trent (1546) took up the matter and decreed that the "ipsa vetus et vulgata editio quae longo tot saeculorum usu in ipsa ecclesia probata" ("the same old and ordinarily used text which has been approved in the church itself by the long usage of so many centuries") should be regarded as authentic (*authentica*). By this they apparently meant the Jerome VS, but did not state in which MS or printed ed it was to be found.

(2) *Sistine edition (1590).*—No further steps were taken for the present to secure a standard official Bible for the church—the private ed of John Hentenius of Louvain serving in the meanwhile until the pontificate of Sixtus V. This pope entrusted the work to a committee under Cardinal Caraffa, but he himself strenuously cooperated. MSS and printed edd were examined, but the original Gr or Heb was to be regarded as decisive in difficulties. The result was published as the Sistine ed of the Vulg by the Vatican press in 1590 (see title on 1st and 2d pages). The text resembles the Stephanus ed of 1540. A new puzzling method of verse enumeration was introduced. As one would expect, there was prefixed to the ed a Bull *Aeternus ille*, etc, in which the divines gave themselves credit for their painstaking labors, and the result was declared the authorized Vulg of the Tridentine Council, "pro vera, legitima, authentica et indubitata, in omnibus publicis privatisque disputationibus . . ." ("by virtue of truth, usage, authenticity and certainty, in all public and private disputes"). Errors of printing were corrected by

the pen or by pasting a slip of paper with the correction over the error. This ed was not to be reprinted for 10 years except at the Vatican, and after that any ed must be compared with the Vatican ed, so that "not even the smallest particle should be altered, added or removed" under pain of the "greater excommunication." Sixtus died the same year, and the Jesuit Bellarmine persuaded Clement VIII to recall the Sixtine ed and prepare another standard Vulg in 1592.

(3) *Clementine edition (1592)*.—In the same year appeared the Clementine ed with a preface by Bellarmine asserting that Sixtus had himself determined to recall his ed on account of printers' errors (from which it was remarkably free). The pains and penalties of the Sixtine Bull were evaded by printing the book as a *Sixtine ed*, actually printing the name of Sixtus instead of Clement on the title-page: *Biblia Sacra Vulgatae Editionis Sixti Quinti Pont. Max. iussu recognita atque edita*. The awkward system of verse enumeration of the Sixtine was dropped. The text itself was rather of the Hentenian type. No future ed was to be printed except on the exact pattern, "even to the smallest particle" of the Vatican ed. Thanks largely to the papal Bull this Clementine ed of 1592 still remains the official VS of the Roman Catholic church. A second ed appeared in 1593, and a third in 1598. Roman Catholic scholars were discouraged from undertaking a new VS, and Protestant scholars were, until recently, too occupied with the original texts.

Bentley's projected ed of the NT never appeared. Under cover of the works of Jerome a corrected text was published by Vallarsi, 1734—really the completion and revision of the ed of Martianay of 1706. Little more was done in the way of critical edd till the latter half of the 19th cent.

(4) *Modern critical editions*.—In 1861 Vercellone reprinted the Clementine Vulg (with an excellent preface), the names of Sixtus and Clement both appearing on the title-page. In 1906 an ed—*Bib Sac Vulgatae ed* by Hetzenauer—was published at Oeniponte. (The majority of recent edd have been confined to the NT or part of it: Tischendorf, *Nov. Test. Lat.: textum Hieronymi . . . restituit*, Leipzig, 1864; Hetzenauer, *Nov. Test. Vulg. ed.: ex Vat. edd. earumque correctorio critice edidit* P. M. H., Oeniponte, 1899.) The Oxford Vulg, prepared by Bishop J. Wordsworth and H. J. White, of which the first part was issued in 1889, is a comprehensive work of great value. P. Corssen published the first instalment of a Vulg NT (*Ep. ad Gal*, Berlin, 1885). This is exclusive of the printed edd of several important MSS. Pope Pius X intrusted the preparation of a revised ed of the Vulg to the Benedictine order—but as yet nothing has appeared.

**V. MSS of the Vulgate.**—To give a satisfactory list would be impossible within our space limits. The number is legion—estimated at about 8,000. As yet the same order has not been called out of the chaos of Vulg and Old Lat MSS in the manner in which Westcott and Hort have reduced the Gr MSS of the NT to a system. The student may conveniently approach the subject in White's list in the 4th ed of Scrivener, *A Plain Intro to the Criticism of the NT*, II, 67 ff, or the longer one by Gregory in Tischendorf's *NT Gr*, 8th ed, III, 983 ff, also in Westcott's art. in *DB* or White's in *HDB*; Vercellone, *Variae Lectiones*, 1860; Berger, *Histoire de la Vulgate*, 374 ff.

**VI. Latinity.**—Space permits only a few general remarks. The Lat of the old VSS was simple, rude and vernacular, abounding in literalisms and provincialisms. In many ways, in vocabulary, diction and construction, it offended scholars. As was natural Jerome smoothed the roughness of the old VSS and removed the most glaring solecisms and offensive provincialisms. His work is a masterpiece—like our AV—in the harmonious blend of

simple, popular, forceful language and a scholarly graceful tr. "As a monument of ancient linguistic power the tr of the OT stands unrivaled and unique" (Westcott). The Vulg has enriched our language by introducing many Gr words, "apostle," "evangel," "synagogue," "baptism," etc. It has also given us much of our theological vocabulary, "edification," "justification," "propitiation," "regeneration," "Scripture," etc. It still retains many marks of its birth in (1) Old Lat words elevated from the vernacular, (2) Africanisms: *clarifico*, etc, *saeculum* for *mundus*, long compound vbs. like *obtenebrare*, etc, (3) Graecisms, like the use of the pronoun for the art., as *hic mundus* = *ὁ κόσμος*, *ho kósmos*, (4) Hebraisms, like *adposuit ut apprehenderet et Petrum* (Acts 12 3; see special works mentioned in "Literature").

**VII. Use of the Vulgate.**—In the OT the Vulg is not of much importance for the criticism of the Heb text, because of the freedom which Jerome permitted himself in tr, and because our present Massoretic Heb text had by that time taken on its present form. But on the LXX it often throws a very useful light. In the NT Jerome's VS ranks practically in importance with our oldest and best Gr MSS in establishing (in conjunction with the Old Lat VSS) the received Gr text of the 4th cent., both by way of supplementing and correcting our Gr authorities. It is in the Gospels that Jerome's work is most thorough and useful. His VS also supplies many a hint for the interpretation of our Gr text.

**VIII. Differences between Vulgate and Our English Version.**—Apart from differences of rendering and minor points, the Vulg text differs from the Eng. in the order of the books, in the amount contained in some of them, in the occasional divergence of chapter and verse enumeration. The NT is practically the same in the Clementine text, though the order of books varies in many MSS—the Catholic Epp. being placed sometimes after Acts. In some MSS the Ep. to the Laodiceans is found. Most variety obtains in the OT. The sequence of canonical books is the same, but the apocryphal books are interspersed among them and not placed at the end. Tob and Jth are inserted between Neh (2 Esd) and Est, Wisd and Ecclus between Cant and Isa. Bar follows Lam, ch 5 of which is called the "Prayer of Jeremiah the prophet"; 1 and 2 Macc are placed after Mal; 3 and 4 Esd and Pr Man appear as an appendix after the NT. In Pss the divergence is considerable, the Vulg—like the Heb—counting the title as the first verse. Pss 9, 10 of our VS = Ps 9 in Vulg, so that the Vulg is one Ps behind the Eng. till Ps 114, then Pss 114, 115 again form one Ps = Vulg 113. The Vulg is now two behind. Matters are equalized by Pss 116 being divided into two in the Vulg (= 114, 115), and 147 again = two Vulg Pss 146, 147. Thus only Pss 1-8 and 148-150 run the same. Against Jerome's advice the apocryphal parts of Dnl and Est were accepted as integral parts of those books, the Three being inserted at Dnl 3 23, Sus forming ch 13 and Bel ch 14. Ad Est is linked on to the end of Est. In conclusion, the present Vulg, as Westcott remarks, is a composite of elements belonging to every period and form of the Lat VS, including (1) unrevised Old Lat (Wisd, Ecclus, 1 and 2 Macc and Bar); (2) Old Lat corrected from the LXX (Psalter); (3) Jerome's free tr from the original (Job and Jth); (4) Jerome's tr from the original (the OT except the Psalter); (5) Old Lat revised from Gr MSS (the Gospels); (6) Old Lat cursorily revised (the rest of the NT).

**LITERATURE.**—This is too vast to cite, but in some of the following works sufficient bibliographies will be found: Berger, *Hist de la Vulg pendant les premiers siècles du moyen âge*, 1893; H. Hody, *De bib. textibus originalibus*, 1705; F. Kaulen, *Gesch. der Vulg*, 1868; Van Ess, *Pragmatisch-krit. Gesch. der Vulg*, 1824; E. Nestle, *Uebersetzungen der Bibel*, 1897, and *Ein Jubiläum d. lat. Bib.*, 1892. Two splendid arts.—each by an authority—in *DB* (Westcott) and in *HDB* (White). A very readable account is in Kenyon, *Our Bible and the Ancient MSS*, 165 ff, and in his *Handbook to the Text Crit. of the NT*, 163 ff. For the language: Rönsch, *Itala v. Vulgata*, 2d ed, 1875; A. Hartl, *Sprachliche Eigentümlichkeiten d. Vulg*, 1894.

S. ANGUS

**VULTURE**, vul'tūr (וּלְטוּר, *dā'āh*; LXX γύψ, *gúps*, and *ἰκτινος*, *iktinos*; Lat *Vulturidae*): Any member of a family of large birds that subsist wholly or in part on carrion. The largest vulture of Pal was the Lammer-geier. This bird waited until

smaller vultures, eagles and hawks stripped a carcass to the bone, then carried the skeleton aloft and dashed it on the rocks until the marrow could be secured. This was a favorite delicacy. This bird was fond of tortoise also, and is said to have dropped the one that struck the bald head of Aeschylus, which the bird mistook for a stone, so causing the death of the poet. Several smaller species, including "Pharaoh's chickens," flocked all over Pal. These were protected by a death penalty for their value as scavengers in cities. They fed on carcasses of animals that killed each other, ate putrid fish under the nests of pelican and cormorant, followed caravans across the desert, and were ready for offal thrown from animals dressed for feasting. They flocked over the altars for the entrails from sacrifice, and devoured scraps cast aside by tent-dwellers

and residents of cities. They paired with affectionate courting and nested in crevices, in walls, hollow trees and on cliffs. They raised only one pair of young to the season, as the nestlings were over two months old before they took wing. The young were white at first, then black feathers enveloped them. On account of their steady diet of carrion, no one ever has been able to use their flesh for food, although some daring ornithologists have tried. For this reason the vulture was placed among the abominations and should by right have headed the lists (Lev 11 18; Dt 14 13). The other references that used to be tr<sup>d</sup> "vulture" in AV (LXX *ἐλαφος*, *élaphos*, Vulg correctly *milous*) are changed to "falcon" and "kite." Isa 34 15 changes "vulture" to "kite." Job 28 7 changes "vulture" to "falcon."

GENE STRATTON-PORTER

## W

WAFER, wā'fēr. See BREAD.

**WAGES**, wā'jez, wā'jiz (הַנָּמ, *hinnām*, מִשְׁכָּרָה, *maskōreth*, מִשְׁכָּרָה, *p<sup>e</sup>ullāh*, שֶׂכָר, *sākhar*, שֶׂכָר, *sākhar*; μισθός, *misthos*, ὀψώνιον, *opsōnion*): (1) *Hinnām* means "gratis," without cost or any advantage, for nought, or in vain; wages in the sense of reasonable return. Jeremiah pronounces woe upon him who "useth his neighbor's service without wages, and giveth him not his hire" (Jer 22 13; the only place where the word is used). (2) *Maskōreth* means "reward" or "wages." Laban said to Jacob: "Shouldest thou therefore serve me for nought? tell me, what shall thy wages be?" (Gen 29 15). Jacob said, concerning Laban, speaking to Rachel and Leah: "Your father hath deceived me, and changed my wages ten times" (Gen 31 7; cf ver 41). (3) *P<sup>e</sup>ullāh* generally means "work," "labor," "reward," "wages." The old Levitical Law was insistent on honesty in wages and on promptness in payments: "The wages of a hired servant shall not abide with thee all night until the morning" (Lev 19 13). (4) *Mistakkēr* means "earning," "hire," "reward," "wages," from root *sākhar*, meaning "to hire," and has in it the idea of temporary purchase: "He that carneth wages carneth wages to put it into a bag with holes" (Hag 1 6). (5) *Sākhar* means "payment of contract," in the material way of salary, maintenance, fare, and so compensation, reward, price, benefit, wages—seemingly wages received after an understanding as to time, manner and amount of payment. Laban (employer) said to Jacob (employee): "Appoint me thy wages, and I will give it" (Gen 30 28); "If he said thus, The speckled shall be thy wages" (Gen 31 8); Pharaoh's daughter said to Moses' mother: "Take this child away, and nurse it for me, and I will give thee thy wages" (Ex 2 9); Nebuchadrezzar and his army served against Tyre, "yet had he no wages, nor his army" (Ezk 29 18), and the prey of Egypt "shall be the wages for his army" (ver 19); swift and sure judgment is predicted against "those that oppress the hireling in his wages, the widow, and the fatherless" (Mal 3 5). (6) *Misthos* means either in a literal or figurative sense "pay for service," either primitive or beneficial, and so reward, hire, wages. In Jn 4 36 Jesus said, "He that reapeth receiveth wages, and gathereth fruit unto life eternal." 2 Pet 2 15 has changed "wages" (AV) to "hire," reading "who loved the hire of wrongdoing." (7) *Opsōnion*, meaning primarily "rations for soldiers" (*opsōn* being the word for cooked meat) and so "pay" or stipend, provision wages. In Lk 3 14 John said to the soldiers, "Be content with

your wages"; "The wages of sin is death" (Rom 6 23); Paul said: "I robbed other churches, taking wages of them" (2 Cor 11 8); the same word in 1 Cor 9 7 is tr<sup>d</sup> "charges."

The Bible refers to wages actual and wages figurative. Of actual wages there are three kinds: (1) money wages, (2) provision (usually food) wages, and (3) what may be called "exchange" wages, wages in kind, sometimes "human-kind," e.g. Jacob's wages from Laban. Often laborers and soldiers received both money and "keep" wages. The laborer in NT times received about 15 cents per day (the "shilling" of Mt 20 2), besides in some cases his provisions. The old Law required daily payment, honesty in dealing, also sufficient food for the laborer.

It is practically impossible to test "Bible" wages by any of the theories of modern economists. In this connection, however, mere mention of the six principal theories may be of interest. Concisely put they are: (1) wage-fund, (2) standard-of-living, (3) German-socialistic, (4) production, (5) Henry George's, and (6) the laborer's-value theories. The incidents in the OT of Jacob and in the NT of Mt 20 both show that the laborer was at the caprice of the employer. Therefore we may designate the Bible law of wages as the "employer's theory."

WILLIAM EDWARD RAFFETY

WAGON, WAGGON, wag'un. See CART.

WAIL, wāl, WAILING, wāl'ing. See BURIAL, III, 2; IV, 4, 5, 6.

WAIT, wāt: The word is used in the OT both as a substantive and as a vb. In the NT it appears as a vb. only. אָרַב, *'erebh*, מִצְרֵיב, *mi'arēbh*,

1. The Sub-*ma'arābh*, mean a concealed hiding-stative place for purposes of sudden attack, an ambushade. (1) "Lie in wait": "Abimelech rose up . . . from lying in wait" (Jgs 9 35 AV); "When they . . . abide in the covert to lie in wait" (Job 38 40). (2) "Lay wait": "They compassed him in, and laid wait for him" (Jgs 16 2).

(1) שָׂרַח, *shārath*, "to serve," "to minister," to act in the capacity of servant or attendant: "These waited on the king" (2 Ch 17 19).

2. The Verb Used esp. in this sense with regard to the ceremonial service of the host: "They shall go in to wait upon the service in the work of the tent of meeting" (Nu 8 24; cf ver 25); "The Levites wait upon their business" (2 Ch 13 10 AV). "Wait at" occurs in the same sense in the NT: "They which wait at [RV "wait upon"] the altar," etc (1 Cor 9 13 AV). (2) The simple vb. is used to describe the longsuffering and patience of God toward His wilful people: "And therefore will Jeh wait, that he may be gracious unto you" (Isa 30 18); "When the longsuffering of God waited in the days of Noah" (ἀπεδέχετομα,

*apekdéchomai*, 1 Pet 3 20). (3) The most important and frequent use of the word "wait," however, is to define the attitude of a soul God-ward. It implies the listening ear, a heart responsive to the wooing of God, a concentration of the spiritual faculties upon heavenly things, the patience of faith, "the earnest expectation of the creation" (Rom 8 19). It describes an eager anticipation and yearning for the revelation of truth and love as it is in the Father. Thus: "My soul, wait thou . . . for God only" (Ps 62 5); "Our soul hath waited for Jeh" (Ps 33 20); "Mine eyes fail while I wait for my God" (Ps 69 3); "Wait for Jeh, and he will save thee" (Prov 20 22).

Also the NT thus: "Waiting for our adoption, to wit, the redemption of our body" (Rom 8 23); "For we through the Spirit by faith wait for the hope of righteousness" (Gal 5 5). From various references in the NT there seems to have been in the days of Jesus a sect in whose name the word "wait" played an important part. Of the aged Simeon, who met Mary and Joseph when they brought the infant Jesus to the temple, it is said that he was "waiting for [RV "looking for"] the consolation of Israel" (Lk 2 25), that is, he was looking for the fulfilment of the Messianic promise. Again, after Our Lord's crucifixion, when Joseph of Arimathea begged for the body of Jesus, we are told that he was one of those that "waited for the kingdom of God" (*προσδέχονται προσδέχονται*, Mk 15 43 AV; Lk 23 51 AV). It is thought by some authorities that this implies their having belonged to the sect of the Essenes. Epiphanius associates the sect with one which he names "Gortheni," whose title is derived from a word which means "to expect."

ARTHUR WALWYN EVANS

**WALK**, wók (*περιπατεῖν, peripatein*): Aside from its frequent occurrence in the usual sense, the word "walk" is used figuratively of conduct and of spiritual states. (1) Observance of laws or customs: "Thou teachest all the Jews who are among the Gentiles to forsake Moses, telling them not to circumcise their children, neither to walk after the customs" (Acts 21 21). (2) Of the spiritual life: "If we walk in the light, as he is in the light" (1 Jn 1 7); "That like as Christ was raised from the dead through the glory of the Father, so we also might walk in newness of life" (Rom 6 4); "Walk by the Spirit, and ye shall not fulfil the lust of the flesh" (Gal 5 16); "For we walk by faith, not by sight" (2 Cor 5 7).  
RUSSELL BENJAMIN MILLER

**WALL**, wól. See ARCHITECTURE; CITY; FORTIFICATION; HOUSE; JERUSALEM; VILLAGE.

**WALLET**, wol'et, -it. See SCRIP.

**WANDERING**, won'dér-ing, **STARS**. See ASTRONOMY.

**WANDERINGS, won'dér-ingz, OF ISRAEL:**

- I. CONDITIONS
  - 1. The Wilderness
  - 2. Four Separate Regions Included
  - 3. "The Sandy Tract"
  - 4. Description of the Arabah
  - 5. Physical Condition of the Wilderness
  - 6. Difficulties Regarding the Numbers of Israel and Account of Tabernacle
  - 7. Difficulty as to Number of Wagons
  - 8. Fauna of the Desert
  - 9. Characteristic Names of the Districts
- II. FIRST JOURNEY
  - 1. Mode of Traveling
  - 2. The Route: the First Camp
  - 3. Waters of Marah
  - 4. Camp by the Red Sea
  - 5. Tho Route to Sinai
- III. SECOND JOURNEY
  - 1. The Stay at Sinai
  - 2. Site of Kadesh-barnea
  - 3. The Route: Hazeroth to Moseroth
  - 4. The Camps between Hazeroth and Moseroth
- IV. THE THIRTY-EIGHT YEARS
  - 1. The History
  - 2. The Camps Visited

V. THE FINAL JOURNEY

- 1. The Route
- 2. The Five Stations to the Border of Moab
- 3. From Iyim to Arnon
- 4. The Message to Sihon
- 5. From the Arnon to Shittim
- 6. Review

**I. Conditions.**—A consideration of the geography and natural features of the desert between Egypt and Edom, in which the Hebrews are said to have wandered for 40 years, has a very important bearing on the question of the genuineness of the Pent narrative. This wilderness forms a wedge between the Gulfs of Suez and 'Akabah, tapering



Wilderness of Judaea.

S. to the granite mountains near Sinai. It has a base 175 miles long E. and W. on the N., and the distance N. and S. is 250 miles. The area is thus over 20,000 square miles, or double the size of the Promised Land E. and W. of Jordan. On the N. of this desert lie the plains of Gaza and Gerar, and the *Neghebb* or "dry region" (the south; see Nu 13 17 RV), including the plateau and low hills round Beersheba.

There are four separate regions included in the area, the largest part (13,000 square miles) being a plateau which on the S. rises 3,000 to 4,000 ft. above the sea, and shelves gently toward the Philii plains. It is drained into the broad *Wady el-Arish*, named from *el-Arish* ("the booth"), a station on the Mediterranean coast S. of Gaza, where this valley enters the sea. In this direction several prominent mountains occur (*Jebel Yelek, J. Hildl, and J. Ikhriim*), while further E.—near the site of the Western Kadesh—there is a step on the plateau culminating on the S. in *Jebel el-Mukhrah*; but none of these ranges appears to be more than about 4,000 ft. above the sea. The plateau is known as *Badiet el-Tih* ("the pathless waste"), and though some Arab geographers of the Middle Ages speak of it as the desert "of the wandering of the Beni Isráil," they refer to the whole region as far as 'Akabah, and not to the plateau alone. The elevation on the S. forms a very steep ascent or "wall" (see SHUR), bending round on the W. and E., and rising above the shore plains near Suez and the 'Arabah near Edom. Near the center of the plateau is the small fort of *Nakhl* ("the palms"), where water is found; but, as a whole, the *Tih* is waterless, having very few springs, the most important being those near the western Kadesh (*Ain Kadis*); for Rehoboth belongs to the region of the *Neghebb* rather than to the *Tih*. In winter, when very heavy rains occur, the valleys are often flooded suddenly by a *seil*, or "torrent," which is sometimes 10 ft. deep for a few hours. Such a *seil* has been known to sweep away trees, flocks, and human beings; yet, in consequence of the hard rocky surface, the flood rushes away to

the sea and soon becomes a mere rivulet. Where soft soil is found, in the valleys, grass will grow and afford pasture, but even early in spring the Arabs begin to suffer from want of water, which only remains in pits and in water holes among rocks. They have then much difficulty in watering their goats and sheep.

Below the *Tih* escarpment on the S. is another region called *Debbet er-ramleh* ("the sandy tract"), which is only 20 miles across at its widest; and to the W. are the sandy plains, with limestone foothills, stretching E. of the Bitter Lakes and of the Gulf of Suez. The third region consists of the granite chain (see *SINAI*) which rises to 8,550 ft. above the sea, and some 6,000 ft. above its valleys, near *Jebel Mûsa*. Parts of this region are better watered than is any part of the *Tih*, and the main route from Egypt to Edom has consequently always run through it.

The fourth region is that of the *'Arabah*, or broad valley (10 miles wide) between the Gulf of *'Akabah* and the Dead Sea. It has a watershed some 700 ft. high above the Gulf (S. of the neighborhood of Petra); and N. of this shed the water flows to the Dead Sea 1,292 ft. below the Mediterranean. The total length of this valley is 120 miles, the watershed being (near the Edomite chain) about 45 miles N. of *'Akabah*. The head of the Gulf was once farther N.; and, near *'Ain Ghudiân* (probably *Ezion-geber*) and *'Ain el-Tâbah* (probably *Jobath*), there is a mud flat which becomes a lake in winter—about 20 miles from the sea. Lower down—at *'Ain ed Deffiyeh*—there is another such flat, the head being 10 miles from *'Akabah*. The whole region is much better watered than either of the three preceding districts, having springs at the foot of the mountains on either side; and the *'Arabah* is thus the best pastoral country within the limits described. It now supports a nomad population of about 2,000 or 3,000 souls (*Haiwaldt* and *'Alawin* Arabs), while the region round *Sinai* has some 2,000 souls (*Towârah* Arabs): the whole of the *Tih* has probably not more than 5,000 inhabitants; for the stronger tribes (*'Azâimêh* and *Terabîn*) live chiefly between *Gaza* and *Beersheba*. These Arabs have goats, sheep and camels, but cattle are only found near *Beersheba*. The flocks are watered daily—as in *Pal* generally—and are sometimes driven 20 miles in winter to find pasture and water. The water is also brought on donkeys and camels to the camps, and carried in goatskin bags on a journey through waterless districts. See also *ARABAH*.

There is no reason to think that the conditions at the time of the *Exodus* differed materially from those of the present time. The Arabs have cut down a good many acacia trees for firewood in recent times, but of the population is too small materially to affect the vegetation. The annual rainfall—except in years of drought—is from 10 to 20 in., and snow falls in winter on the *Tih*, and whitens *Sinai* and the Edomite mountains for many days. The acacia, tamarisk and palm grow in the valleys. At *Wâdy Feirân* there are said to be 5,000 date palms, and they occur also in the *'Arabah* and the Edomite gorges, while the white broom (1 K 19 5, AV "juniper") grows on the *Tih* plateau. This *Tih* plateau is the bed of an ancient ocean which once surrounded the granite mountains of *Sinai*. It was upheaved probably in the Miocene age, long before man appeared on earth. The surface formation (Hull, *Memoir on the Geology and Geography of Arabia-Petraea*, etc, 1886) consists of Cretaceous limestones of the Eocene and Chalk ages, beneath which lies the Nubian sandstone of the Greensand period, which is also visible all along the route from *Sinai* to *'Akabah*, and on the east side of the Dead Sea, and even at the foot of the *Gilead* plateau. These beds are all visible in the *Tih* escarpment; and N. of *Sinai* there are yet older formations of limestone, and the "desert sandstone" of the Carboniferous period. Since the conditions of natural water-supply depend entirely on geological formation and on rainfall, neither of which can be re-

garded as having changed since the time of Moses, the scientific conclusion is that the desert thus described represents that of his age. This, as we shall see, affects our conclusion as to the route followed by Israel from Egypt to the *'Arabah*; for, on the direct route from *Suez* to *Nakhl* (about 70 miles), there is no water for the main part of the way, so it has to be carried on camels; while, E. of *Nakhl*, in a distance of 80 miles, there is only one known supply in a well (*Bir eth-Themed*) a few miles S. of the road. This route was thus practically impassable for the Hebrews and their beasts, whereas the *Sinai* route was passable. Thus when *Wellhausen* (*Hist of Israel and Judah*, 343) speaks of Israel as going straight to *Kadesh*, and not making a "digression to *Sinai*," he seems not to have considered the topography as described by many modern travelers. For not only was the whole object of their journey first to visit the "Mount of God," but it also lay on the most practicable route to *Kadesh*.

It is true that there are certain difficulties as regards both the numbers of Israel and the account of the tabernacle. The first of these objections has been considered elsewhere (see *EXODUS*). The detailed account of the tabernacle (Ex 25-28; 36-39) belongs to a part of the Pent which many critical writers assign to a later date than that of the old narrative and laws (Ex 1-24). The description may seem more applicable to the semi-permanent structure that existed at *Shiloh* and *Nob*, than to the original "tent of meeting" in the desert. On the other hand, living so long in civilized Egypt, the Hebrews no doubt had among them skilled artificers like *Bezalel*. The Egyptians used acacia wood for furniture; and though the desert acacia does not grow to the size which would furnish planks 1½ cubits broad, it may be that these were made up by joiner's work such as the ancients were able to execute. There was plenty of gold in Egypt and Asia, but none near *Sinai*. It is suggested, however, that the ornaments of which the Hebrews spoiled the Egyptians were presented, like the stuffs (Ex 36 6) wrought for the curtains—just as the Arabs weave stuffs for their tents—and they might have served to spread a thin layer of gold over acacia boards, and on the acacia altar. It is more difficult to understand (on our present information) where silver enough for the bases (Ex 26 25) would be found. Copper (27 4) presents less difficulty, since there were copper mines in *Wâdy Nusub* near *Serâbit el Khâdim*. The women gave gold earrings to *Aaron* (32 3) for the Golden Calf; but this may have been a small object. *Eusebius* (*Onom*), referring to *Dizahab*, "the place of gold" (Dt 1 1), now *Dhahab* ("gold") on the west shore of the Gulf of *'Akabah*, E. of *Sinai*, mentions the copper mines of *Punon*, and thought that veins of gold might also have existed in the mountains of Edom in old times. A little gold is also found in *Midfan*. We know that the Egyptians and Assyrians carried arks and portable altars with their armies, and a great leather tent of *Queen Habasu* actually exists. *Thothmes III.*, before the *Exodus*, speaks of "seven tent poles covered with plates of gold from the tent of the hostile king" which he took as spoil at *Megiddo*. The art of engraving gems was also already ancient in the time of Moses. See *NUMBERS*, BOOK OF.

Another difficulty is to understand how six ox wagons (Nu 7 3) sufficed to carry all the heavy planks and curtains, and vessels of the tabernacle; and though the use of ox carts, and of four-wheeled wagons also, is known to have been ancient in Asia, there are points on even the easiest route which it would seem impossible for wagons to pass, esp. on the rough road through Edom and Moab. On the other hand, we know that an *Egypt Mohar* did drive his chariot over the mountains in *Pal* in the reign of *Rameses II.*, though it was finally broken near *Joppa*.

Whatever be thought as to these questions, there are indications in other passages of actual acquaintance with the desert fauna. Although the manna, as described (Ex 16 31), is said not to resemble the sweet gum which exudes from the twigs of the tamarisk (to which it has been compared by some), which melts in the sun, and is regarded as a delicacy by the Arabs, yet the quail (Ex 16 13; Nu 11

### 4. Description of the Arabah

3. "The Sandy Tract"

### 6. Difficulties

### 7. Difficulty as to Numbers of Wagons

### 8. Fauna of the Desert

31) still migrate from the sea northward across the desert in spring, flying low by night. The birds noticed (Lev 11; Dt 14) include—as Canon Tristram remarked—species found on the seashores and in the wilderness, such as the cormorant, pelican and gull; the ostrich (in the desert E. of Moab); the stork, the crane and the heron which migrate from Africa to the Jordan valley. It is notable that, excepting the heron (Assyr *anpatu*), the Heb names are not those used by later Assyrians. The mammals include the boar which loves the marshes, and the hyrax (AV “coney”) which still exists near Sinai and in the desert of Judah, with the desert hare. It is remarkable that in Dt (14 5), besides the ibex and the bubak, two species are added (the fallow deer, Heb *'ayyāl*, AV “hart,” and the roebuck, Heb *yahmūr*, Arab. *yahmūr*, AV “fallow deer”) which are not desert animals. The former occurs at Tabor; the latter was found by the present writer in 1873 on Carmel, and is since known in Gilead and Lebanon. But Dt refers to conditions subsequent to the capture of Gilead and Bashan.

The various districts in the desert receive characteristic names in the account of the Exodus.

Thus Shur is the coast region under the 9. Charac- “wall” of the *Tih*, and Sin (Ex 17 1; Nu 33 11) was the “glaring” desert Names of (see SINAI) of white chalk, W. of Sinai. the Districts Paran is noticed 10 t, as a desert and mountain region (Dt 33 2; Hab 3 3) between Sinai and Kadesh. The name seems to survive in *Wādy Feirān* W. of Sinai. It means some kind of “burrows,” whether referring to mines, caves or water pits, according to the usual explanation; but in Arab. the root also means “hot,” which is perhaps more likely. The term seems to be of very wide extension, and to refer to the *Tih* generally (Gen 21 21); for David (1 S 25 1) in Paran was not far from Maon and Carmel S. of Hebron, and the same general application (1 K 11 18) is suggested in another passage. Finally the desert of Zin (*zīn*) is noticed 9 t, and very clearly lay close to Kadesh-barnea and E. of Paran (Nu 13 21; 20 1; 34 3; Dt 32 51; Josh 15 3). The rabbis rendered it “palm” (*zīn*), which is appropriate to the *'Arabah* valley which still retains the old name mentioned in Dt 1 1. These various considerations as to the conditions to be fulfilled may serve to show that the difficulties often raised, as to the historic character of the Exodus narrative, have been much overstated; and a further study of the various journeys serves to confirm this view.

II. **First Journey.**—Israel left Egypt in the early part of April (after the 14th of Abib) and reached Sinai about the 14th or 19th of the

1. **Mode of Traveling** 3d month (Ex 19 1), or at the end of May. They thus took two months to accomplish a journey of about 117 miles; but from the first camp after crossing the Red Sea to that in the plain before the Mount ten marches are mentioned, giving intervals of less than 12 miles between each camp. Thus they evidently remained in camp for at least 50 days of the time, probably at the better supplied springs, including that of the starting-point, and those at Elim and Rephidim, in order to rest their flocks. The camps were probably not all crowded round one spring, but spread over a distance of some miles. The Arabs indeed do not camp or keep their flocks close to the waters, probably in order not to defile them, but send the women with donkeys to fetch water, and drive the sheep and goats to the spring or well in the cool of the afternoon. Thus we read that Amalek “smote the hindmost” (Dt 25 18), which may either mean the stragglers unable to

keep up when “weary,” or perhaps those in the camp most in the rear.

The route of Israel has been very carefully described by Robinson (*BR*, 1838, I, 60–172; II, 95–195), and his account is mainly followed in this and the next sections.

2. **The Route: the First Camp** may place the first camp (see *EXODUS*) between the springs which supply

Suez (*'Ain Nāb'a* and *'Ayyūn Mūsa*), which are about 4 miles apart. The first of these is scooped out among the sand hillocks, and bubbles up in a basin some 6 ft. deep. The water is brackish, but supplies as many as 200 camel loads at once for Suez. At *'Ayyūn Mūsa* (“the springs of Moses”) there are seven springs, some being small and scooped in the sand. A few palms occur near the water (which is also brackish), and a little barley is grown, while in recent times gardens of pomegranates have been cultivated (A. E. Haynes, *Man-Hunting in the Desert*, 1894, 106), which, with the palms, give a grateful shade.

From this base Israel marched “three days in the wilderness” of Shur, “and found no water” (Ex 15 22). They no doubt carried it with

3. **The Waters of Marah** them, and may have sent back camels to fetch it. Even when they reached the waters of Marah (“the bitter”) they found them undrinkable till

sweetened. The site of Marah seems clearly to have been at *'Ain Hawārah* (“the white chalk spring”), named from the chalky mound beside it. This is 36 miles from *'Ayyūn Mūsa*, giving an average daily march of 12 miles. There is no water on the route, though some might have been fetched from *'Ain Abu Jerād* in *Wādy Sudr*, and from the small spring of *Abu Suweirah* near the sea. Burckhardt thought that the water was sweetened from the berries of the *Gharḳad* shrub (which have an acid juice) on the thorny bushes near the spring. This red berry ripens, however, in June. There is no doubt, on the other hand, that the best treatment for brack water is the addition of an acid taste. The Arabs consider the waters of this spring to be the most bitter in the country near.

From Marah, the next march led to Elim (“the palms”), where were “twelve springs [not “wells”] of water and seventy palms.” The

4. **The Camp by the Red Sea** site seems clearly to have been in *Wādy Gharandil*, where a brook is found fed by springs of better water than that of Marah. The distance is only about 6 miles, or an easy march, and palm trees exist near the waters. Israel then entered the desert of Sin, stretching from Elim to Sinai, reaching a camp “by the Red Sea” (Nu 33 10) just a month after leaving Egypt (Ex 16 1). The probable site is near the mouth of *Wādy et-Taiyibeh* (“the goodly valley”), which is some 10 or 12 miles from the springs of *Gharandil*. The foothills here project close to the coast, and N. of the valley is *Jebel Hammām Far'ān* (“the mountain of Pharaoh's hot bath”), named from hot sulphur springs. The water in *Wādy et-Taiyibeh* is said to be better than that of Marah, and this is the main Arab watering-place after passing *Gharandil*. A small pond is here described by Burckhardt at *el-Murkhat*, in the sandstone rock near the foot of the mountains, but the water is bitter and full of weeds, moss and mud. The site is close to a broad shore plain stretching S. Here two roads diverge toward Sinai, which lies about 65 miles to the S.E., and in this interval (Nu 33 11–15) five stations are named, giving a daily march of 13 miles. The Hebrews probably took the lower and easier road, esp. as it avoided the Egypt mines of *Wādy el-Maghārah* (“valley of the cave”) and their station at *Serābit el-Khādīm* (“pillars of the servant”), where—though this is

not certain—there may have been a detachment of bowmen guarding the mines.

None of the five camps on this section of the route is certainly known. **Dophkah** apparently means

### 5. The

**Route to Sinai**

“overdriving” of flocks, and **Alush** (according to the rabbis) “crowding,” thus indicating the difficulties of the march. **Rephidim** (“refreshments”) contrasts with these names and indicates a better camp.

The site, ever since the 4th cent. AD, has always been shown in *Wady Feirân* (Eusebius, *Onom*, s.v. “Rephidim”)—an oasis of date palms with a running stream. The distance from Sinai is about 18 miles, or 14 from the western end of the broad plain *er-Râhah* in which Israel camped in sight of Horeb; and the latter name (Ex 17 6) included the Desert of Sinai even as far W. as Rephidim. Here the rod of Moses, smiting the rock, revealed to the Hebrews an abundant supply, just as they despaired of water. Here apparently they could rest in comfort for some three weeks before the final march to the plain “before the mount” (Ex 19 1.2), which they reached two months after leaving Egypt. Here Amalek—coming down probably from the mines—attacked them in the rear. Meanwhile there was ample time for the news of their journey to reach Midian, and for the family of Moses (Ex 18 1–5) to reach Sinai. On one of the low hills near *Wady Feirân*, Moses watched the doubtful fight and built his stone altar. A steep pass separates the oasis from the *Râhah* plain, and baggage camels usually round it on the N. by *Wady esh-Sheikh*, which may have been the actual route. The Rephidim oasis has a fertile alluvial soil, and the spot was chosen by Christian hermits perhaps as early as the 3d cent. AD.

**III. The Second Journey.**—Israel remained at Mt. Sinai for 10 months, leaving it after the Passover of the “second year” (Nu 9 1–3), and apparently soon after the feast, since, when they again witnessed the spring migration of the quail (11 31)

### 1. The Stay at Sinai

“from the sea”—as they had done in the preceding year (Ex 16 13) farther W.—they were already about 20 miles on their road, at **Kibroth-hattaavah**, or “the graves of lust.”

(1) In order to follow their journey it is necessary to fix the site of Kadesh-barnea to which they were going, and there has been a good deal of confusion as to this city since, in 1844, Rev. John Rowlands discovered the site of the western Kadesh, at ‘*Ain Kadis*’ in the northern part of the *Tih*.

Robinson pointed out (*BR*, II, 194, n. 3) that this site could not possibly be right for Kadesh-barnea; and, though it was accepted by Professor Palmer, who visited the vicinity in January, 1870, and has been advocated by Henry Clay Trumbull (*Kadesh-barnea*, 1884), the identification makes hopeless chaos of the OT topography. The site of ‘*Ain Kadis*’ is no doubt that of the Kadesh of Hagar (see *SNR*), and a tradition of her presence survives among the Arabs, probably derived from one of the early hermits, since a small hermitage was found by Palmer in the vicinity (*Survey of Western Pal*, Special Papers, 1881, 19). But this spring is not said to have been at the “city” of Kadesh-barnea, which is clearly placed at the southeast corner of the land of Israel (Josh 15 3), while, in the same chapter (ver 23), another site called Kadesh is mentioned, with Adadah (‘*Ada’deh*’ 7 miles S.E. of Arad) and Hazor (at *Jebel Hadîreh*); this Kadesh may very well have been at the western Kadesh.

(2) Kadesh-barnea is noticed in 10 passages of the OT, and in 16 other verses is called Kadesh only. The name probably means “the holy place of the desert of wandering,” and—as we shall see—the

wanderings of Israel were confined to the ‘*Arabah*’. The place is described as “a city in the uttermost . . . border” of Edom (Nu 20 16), Edom being the “red land” of Mt. Seir, so called from its red sandstones, as contrasted with the white *Tih* limestone. It is also very clearly placed (Nu 34 3.4) S. of the Dead Sea (cf Josh 15 3), while Ezekiel also (47 19) gives it as the southeastern limit of the land, opposed to Tamar (*Tamrah* near Gaza) as the southeastern border town. A constant tradition, among Jews and Christians alike, identifies Kadesh-barnea with Petra, and this as early as the time of Jos, who says that Aaron died on a mountain near Petra (*Ant*, IV, iv, 7), and that the old name of Petra was *Arekem* (vii, 1). The Tg of Onkelos (on Nu 34 4) renders Kadesh-barnea by “*Rekem of the G’aila*,” and this name—meaning “many-colored”—was due to the many-colored rocks near Petra, while the *g’aila* or “outery” is probably that of Israel at Meribah-kadesh (Nu 27 14), and may have some connection with the name of the village *el-Jûi*, at Petra, which is now called *Wady Mûsa* (“the valley of Moses”) by the Arabs, who have a tradition that the gorge leading to Petra was cloven by the rod of Moses when he struck the rock at the “waters of strife” (Nu 27 14), forming the present stream which represents that of “Meribah of Kadesh.” Eusebius also (*Onom* s.v. “Barne”) connects Kadesh with Petra, and this traditional site so fully answers the requirements of the journey in question that it may be accepted as one of the best-fixed points on the route, esp. as the position of Hazeroth agrees with this conclusion. **Hazeroth** (Nu 11 35; 12 16; 33 17; Dt 1 1) means “inclosures,” and the name survives at ‘*Ain Hadrah*’ (“spring of the inclosure”) about 30 miles N.E. of Mt. Sinai on the way to the ‘*Arabah*’. It was the 3d camp from Sinai, the 1st being *Taberah* (Nu 11 3) and the 2d *Kibroth-hattaavah* (11 35), giving a daily march of 10 miles. See **KADESH-BARNEA**.

After passing Hazeroth (12 16; 13 3) the journey appears to have been leisurely, and Israel probably camped for some time in the best pastures of the ‘*Arabah*’. For the spies were sent

### 3. The

**Route:**

**Hazeroth to Moseroth**

from Paran near Hazeroth to explore the route to Kadesh, and to examine the “south country” through which Israel hoped to enter Pal (13 17.21). They explored this district (13 21; 32 8) from “the wilderness of Zin,” or otherwise “from Kadesh-barnea,” on the E., to Rehob—probably Rehoboth (now *er-Ruheibeh*)—on the W.; and—having been absent 40 days (13 25)—after visiting Hebron (ver 22) they returned by the direct route leading S. of Arad (*Tell Arad*) to Petra, which road is called (21 1) the “way of the spies.” On their return, in the season of “first-ripe grapes” (13 20), they found Israel at Kadesh (13 26). No place N. of Hebron is mentioned in the account of their explorations, and it is difficult to suppose that, in 40 days, they could have reached the Syrian city of Hamath, which is some 350 miles N. of Petra, and have returned thence. The definition of Rehob (mentioned before Hebron) as being “on the coming to Hamath” (13 21) is best explained as a scribe’s error, due to an indistinct MS, the original reading being *hâlâçeth* (חַלְצֵת), and referring to the classical *Elusa* (now *Khalasah*) which lies 10 miles N. of Rehoboth on the main road to Beersheba and Hebron. Israel left Sinai in the spring, after the Passover, and was near Hazeroth in the time of the quail migration. Hazeroth possesses the only perennial supply of water in the region, and from its vicinity the spies set forth in August.

Most of the sites along this route are unknown, and their position can only be gathered from the meaning of the names; but the 6th station from Hazeroth was at Mt. Shepher (Nu 33 23), and may have left its name corrupted into *Tell el-Asfar* (or ‘*Asfar*’), the Heb meaning “the shining hill,” and the Arab.

**4. The Camps between Hazeroth and Moseroth**

This site is 60 miles from Hazeroth, giving a daily march of 10 miles. As regards the

other stations, **Rithmah** means "broomy," referring to the white desert broom; **Rimmon-perez** was a "cloven height," and **Libnah** a "white" chalky place; **Rissah** means "dewy," and **Kehelathah**, "gathering." From Mt. Shepher the distance to the vicinity of Mt. Hor is about 55 miles, and seven stations are named, giving an average march of 8 miles. The names are **Haradah** (Nu 33 24), "fearful," referring to a mountain; **Makheleth**, "gatherings"; **Tahath**—probably "below"—marking the descent into the 'Arabah; **Terah**, "delay," referring to rest in the better pastures; **Mithkah**, "sweetness" of pasture or of water; **Hashmonah**, "fatness"; and **Moseroth**, probably meaning "the boundaries," near Mt. Hor. These names, though now lost, agree well with a journey through a rugged region of white limestone and yellow sandstone, followed by a descent into the pastoral valley of the 'Arabah. The distances also are all probable for flocks.

**IV. The Thirty-eight Years.**—From the time of their first arrival at **Kadesh-barnea**, in the autumn of the 2d year, to the day that the

**1. The History** Hebrews crossed the brook **Zered** in Moab on their final march, is said to have been a period of 38 years (Dt 2 14), during which the first generation died out, and a strong race of desert warriors succeeded it. During this period Israel lived in the nomadic state, like modern Arabs who change camp according to the season within well-defined limits, visiting the higher pastures in summer, and wintering in the lower lands. On their first arrival near **Kadesh-barnea**, they were discouraged by the report of the spies, and rebelled; but when they were ordered to turn S. "by the way of the Red Sea" or Gulf of 'Akabah, they made an unsuccessful attempt to enter Pal by the way of the spies (Nu 14 25-45). They were discomfited by Amalekites at **Hormah** ("cutting off"), which place is otherwise called **Zephath** (Jgs 1 17). Here also they were again defeated by the king of Arad (Nu 21 1.3) in the early autumn of the 40th year of wandering. This site may well be placed at the ascent now called **Nukb es-Sufah** ("the pass of Zephath"), which preserves the Heb name, 45 miles N.W. of Mt. Hor, on the main road from Hebron to Petra. The route is well watered, and **Ain Yemen** is a spring at the foot of this ascent leading to the higher terrace of the **Tih**. Arad lies N. of the road, and its Can. king no doubt marched S. some 40 miles, to defend the top of the ascent down which the Amalekites had driven the first generation of Hebrews, who returned to the **Kadesh-barnea** camp.

We are not left without any notice of the stations which Israel visited, and no doubt revisited annually, during the 38 years of nomadic

**2. The Camps Visited** life. We have in fact three passages which appear to define the limits of their wanderings. (1) In the first of these (Nu 33 31-36) we find that

they left **Moseroth**, near Mt. Hor, the site of which latter has always been shown—since the time of Jos at least—at the remarkable mountain W. of Petra, now called **Jebel Hârûn** ("Aaron's Mountain"); thence they proceeded to the wells of the **Bene-jaakan**, to **Hor-haggidgad**, and to **Jotbathah**. **Hor-haggidgad** (or **Gudgodah**, Dt 10 7) signifies apparently the "hill of thunder," and the word is not in any way connected with the name of **Wâdy Ghadaghîd** ("the valley of failing waters"), applying to a ravine W. of the 'Arabah; for the Heb and Arab. words have not a letter in common. The site of **Jotbathah**, which was in "a land of brooks of waters" (Dt 10 7), is, on the other hand, pretty clearly to be fixed at **Ain et-Tâbah** ("the good

spring"), 28 miles N. of 'Akabah, and about 40 along the road from Mt. Hor. This spring, near a palm grove, feeds the winter lake of **el-Tâbah** to its W. in the 'Arabah. The next station was **Abronah** ("the crossing"), and if this refers to crossing the 'Arabah to the western slopes, we are naturally brought—on the return journey—to **Ezion-geber**, at **Ain-ghudîan** (the usual identification), which springs from the western slopes of the **Tih** on the side of the lake opposite to **Jotbathah**. Thence the migrants gradually returned to **Kadesh**.

(2) The second passage (Dt 10 6.7) is one of many geographical notes added to the narrative of the wanderings, and gives the names in a different order—Wells of the **Bene-jaakan**, **Moserah**, **Gudgodah**, and **Jotbathah**—but this has little importance, as the camps, during 38 years, would often be at these springs.

(3) The third passage is in the preface to Dt (1 1.2), which enumerates the various places where Moses spoke to Israel at various times after leaving Sinai. These include the region E. of Jordan, the wilderness, the 'Arabah, "over against Suph," with all the district between **Paran** and **Tophel** (now **Tufîleh**, on the southern border of Moab), as well as **Laban** (probably the **Libnah** of Nu 33 20), **Hazeroth**, and **Dizahab** which may be **Dhahab** on the seashore E. of Sinai. This list, with the valuable notes added showing that **Kadesh-barnea** was 11 days from **Horeb** in the direction of Mt. Seir, refers to speeches down to the last days of Moses' life. The wanderings of the 38 years do not include the march through **Edom** and **Moab**; and, though it is of course possible that they may have extended to **Hazeroth** and **Sinai**, it seems more probable that they were confined to the 'Arabah between **Petra** and **Jotbathah**. **Elath** (now 'Akabah), on the eastern shore at the head of the gulfs, is not mentioned; for the raised beach S. of the Lake of **Jotbathah** would not give pasture. In summer the camps would be on the western slopes of the valley, where grass might be found in April; and the annual migrations were thus within the limits of some 500 sq. miles, which is about the area now occupied by a strong tribe among Arabs.

**V. The Final Journey.**—In the 1st month of the 40th year (Nu 20 1) Israel was at **Kadesh** in the desert of **Zin**, where **Miriam** was buried.

**1. The Route** They were troubled once more by want of water, till Moses smote the rock of **Meribah** ("strife"). They were commanded to keep peace with their relatives of **Edom** and **Moab**, whose lands were not attacked by the Hebrews till the time of **Saul**, and of **David** and his successors. They camped on the border of **Kadesh**, desiring to reach the main road to **Moab** through the city; and, when this was refused by the king of **Edom**, they withdrew a few miles W. to **Mt. Hor**. Here **Aaron** was buried, and was mourned for 30 days (Nu 20 29), after which the 2d attempt to reach **Hebron** by the main road (21 1) was also repulsed. Since, on this occasion, Israel remained "many days" in **Kadesh** (Dt 1 46) and left it less than 38 years after they first reached it in autumn, it would seem that they may have started in August, and have taken about a month to reach the brook **Zered**; but only five stations are noticed (Nu 21 10-12; 33 41-44) on the way. They are not said—in any passage—to have gone to **Elath**, but they turned "from mount **Hor** by the way to the Red Sea, to compass the land of **Edom**" (Nu 21 4), or, as otherwise stated (Dt 2 8), they went "from the way of the **Arabah**" on the road which led "from **Elath** and from **Ezion-geber**"; and thus, starting on the "way to the Red Sea," they "compassed mount **Seir** many days," turning "northward" by the "way of the wilderness of



Moab" (Dt 2 1.8) after passing through the coast of Edom (2 4).

If the list of five stations is complete, we may suppose that they left the 'Arabah road not many miles S. of Petra, striking E. by an existing road leading to *Mā'an*, and thus gaining the high plateau above Petra to the E., and reaching the present *Hāj* route. This view is confirmed by the notice of Punon as the 2d camp, if we accept the statement of Eusebius (*Onom.* s.v. "Phinon"); for he appears to have known it as an Edomite village N. of Petra, in the desert, where convicts were employed digging copper. The name, however, has not been recovered. The preceding camp at Zalmonah suggests some "gloomy" valley leading up to the Edomite plateau. N. of Punon, the 3d camp was at Oboth ("water bags"), and the 4th was at Iyim or Iye-abarim ("the ruins" or "the ruins of the crossings"), the site of which is pretty certainly at *Aimeh*, a few miles N. of Tophel. The total distance thus seems to have been about 60 miles for four marches, or 15 miles a day. Iyim was "in the border of Moab" (Nu 33 44) and in the desert facing Moab, in the East (21 11).

### 2. The Five Stations to the Border of Moab

Here therefore Israel left Edom; and between Iyim and the river Arnon, in a distance of about 32 miles, only one station is mentioned, being at the valley of Zered (21 12; Dt 2 13.14). This has usually been placed at *Wādy el-Hesy* ("the pebbly valley"), which flows into the Dead Sea, having its head near Iyim; but this is evidently too far S., and it is no doubt the great gorge at *Kerak* that is intended, having its head close to the *Hāj* road, half-way from Iyim to Arnon, giving a daily march of 16 miles. The traditional identification of the Arnon with *Wādy Mōjib* is rendered certain by the positions of *Diban* (*Dhibān*) and *Aroer* (*Ar'ār*) close by. It was the border of the Amorites, who had driven the Moabites S. of this river (Nu 21 13; Dt 2 36), depriving them of their best lands which stretched to Heshbon. These Amorites were apparently recent intruders who, with the Hittites (see HITTITES), had invaded Damascus and Bashan from North Syria, and who no doubt had thus brought the fame of Balaam from Pethor (Nu 22 5), on the Euphrates near Carchemish.

The Hebrews were now a strong people fit for war, and Moses sent messengers from the "wilderness of Kedemoth" (Dt 2 26) to Sihon in Heshbon, demanding a peaceful passage through his lands, such as had been accomplished through Edom and Moab. Kedemoth ("the Eastern Lands") was evidently the desert of Moab.

It was objected, by Colenso, to the narrative of the Pent that, since Israel only reached the brook Zered in autumn of the 40th year, only six months are left for the conquest of North Moab, Gilead and Bashan. But it must be remembered that the Hebrews left all their impedimenta in the "plains of Moab" (Nu 22 1) opposite Jericho at Shittim, so that the advance of their army in Gilead and Bashan was unimpeded. The Assyrians, in later times, covered in a season much longer distances than are attributed to Heb conquerors, and the six months leave quite enough time for the two missions sent from Moab (Nu 22 5-36) to fetch Balaam. See NUMBERS, BOOK OF.

(1) It is notable that, for the march from the Arnon to Shittim, we have two lists of stations. That which is said to have been written down by Moses himself (Nu 33 45-49) mentions only four stations in a distance of about 25 miles—namely *Dibon-gad*, *Almon-diblathaim*, *Nebo* and the plains of *Moab*, where the camps were placed at various waters from Beth-jeshimoth (*Sdeimeh*) on the northeastern shore of the Dead Sea to Abeshittim ("the Meadow of Acacias"), now called the *Ghōr es-Seisebān*, or "Valley of Acacias." In this area of 50 square miles there were four running streams, besides springs, and excellent pasture for flocks. This therefore was the headquarters of the nation during the Amorite war.

(2) In the 2d list (Nu 21 13-20) we read of a still more gradual and cautious advance in the Amorite lands, and this may represent the march of the main body following the men of war. Leaving the Arnon, they reached "a well" (*Beer*), probably near *Dihon*, this being one of those shallow water pits which the Arabs still scoop out in the valleys when the water runs below the surface. Between Arnon and Pisgah (or Nebo) no less than five stations are noticed in about 20 miles, namely *Beer*, *Mattanah* ("the gift"), *Nahaiel* ("the valley of God"), *Bamoth* (or *Bamoth-Baal* [Nu 22 41], "the monuments of Baal"), and *Pisgah* (*Jebel Neba*). Of these only the last is certainly known, but the central station at *Nahaiel* may be placed at the great gorge of the *Zerka Mā'ain*, the road from *Dibon* to *Nebo* crossing its head near *Beth-meon*. There was plenty of water in this vicinity. The last stage of Israel's march thus seems to represent a program of only about 4 miles a day, covered by the more rapid advance of the fighting men; and no doubt the women, children and flocks were not allowed to proceed at all until, at least, *Sihon* had been driven from *Heshbon* (Nu 21 21-25).

We have thus considered every march made by the Hebrews, from Egypt to *Shittim*, by the light of actual knowledge of their route.

6. Review We have found no case in which the stations are too far apart for the passage of their beasts, and no discrepancies between any of the accounts when carefully considered. If, as some critical writers think, the story of the spies and the list of camps said to have been written down by Moses are to be attributed to a Heb priest writing in Babylonia, we cannot but wonder how he came to be so accurately informed as to the topography of the wilderness, its various regions, its water-supply and its natural products. It does not seem necessary to suppose a "double source," because, in the spring of two successive years, the manna is noticed, and Israel is recorded as having eaten the quail flying (as now) by night to the Jordan valley from Africa. The march was not continuous, and plenty of time is left, by the recorded dates, for the resting of the flocks at such waters as those of *Elim*, *Rephidim* and *Hazeroth*. The wanderings of the 38 years represent a nomadic life in the best pastures of the region, in and near the 'Arabah. Here the new race grew up—hardly as the Arabs of today. When they left Egypt the Pharaoh still had a firm hold on the "way of the Philistines," and the Canaanites owned his sway. But 40 years later Egypt was defeated by the Amorites, and the forces of the Pharaoh were withdrawn from *Jerus* after suffering defeat in *Bashan* (see *Am Tab*, no. 64, *Brit. Mus.*, where no less than nine known places near *Ashteroth* and *Edrei* are noticed); general chaos then resulted in Southern Pal, when the 'Abiri (or Hebrews) appeared from *Seir*, and "destroyed all the rulers" (see *Exodus*). This, then, was the historic opportunity for the defeat of the Amorites, and for *Joshua's* conquest of the Promised Land.

C. R. CONDER

WAR, wôr, WARFARE, wôr'fâr (מִלְחָמָה, *mîlḥāmāh*, "מִלְחָמָה", *'anshē m.*, "men of war," "soldiers"; πόλεμος, *pólemos*, πολεμῖν, *polemeîn*, στρατεύεσθαι, *strateuesthai*, στρατιά, *stratiá*):

- |                           |                        |
|---------------------------|------------------------|
| 1. Religious Significance | 7. Defeat and Victory  |
| 2. Preliminaries          | 8. Spoils and Trophies |
| 3. Operations of War      | 9. Treaties of Peace   |
| 4. Strategy               | 10. War in the NT      |
| 5. Important Requisites   | LITERATURE             |
| 6. Characteristics        |                        |

From an early period of Heb history war had a religious significance. The Hebrews were the people of *Jeh*, and they were reminded in their religious wars by the priest or priests who accompanied their armies that *Jeh* was with them to fight their battles (Dt 20 1-4). It was customary to open a campaign, or to enter an engagement, with sacrificial rites (1 S 7 8-10; 13 9). Hence, in the Prophets, to "prepare" war is to carry out the initiatory religious

rites and therefore to "sanctify" war (Jer 6 4; 22 7; 51 27.28; Mic 3 5; Joel 3 9; RVm in each case); and Isaiah even speaks of Jeh mustering His host and summoning to battle His "consecrated ones" (Isa 13 3), the warriors consecrated by the sacrifices offered before the war actually opened. The religious character attaching to war explains also the taboo which we find associated with it (Dt 20 7; 23 10; 2 S 11 11).

(1) *Religious preliminaries*.—It was in keeping with this that the oracle should be consulted before a campaign, or an engagement (Jgs 20 18 ff; 1 S 14 37; 23 2; 23 6; liminaries 30 8). The ark of God was believed to be possessed of special virtue in assuring victory, and, because it was identified in the eyes of the Israelites with the presence of Jeh, it was taken into battle (1 S 4 3). The people learned, however, by experience to put their trust in Jeh Himself and not in any outward token of His presence. At the battle of Ebenezer the ark was taken into the fight with disastrous results to Israel (1 S 4 4 ff). On the other hand at the battle of Michmash, the sacred ephod at Saul's request accompanied the Israelites into the field, and there was a great discomfiture of the Philis (1 S 14 18). In the later history prophets were appealed to for guidance before a campaign (1 K 22 5; 2 K 3 11), although fanatical members of the order sometimes gave fatal advice, as to Ahab at Ramoth-gilead, and probably to Josiah at Megiddo. Upon occasion the king addressed the host before engaging the enemy (2 Ch 20 20-22, where Jehoshaphat also had singers to go before the army into battle); and Judas Maccabaeus did so, with prayer to God, on various occasions (1 Macc 3 58; 4 30; 5 32).

(2) *Military preliminaries*.—The call to arms was given by sound of trumpet throughout the land (Jgs 3 27; 6 34; 1 S 13 3; 2 S 15 10; 20 1; cf Nu 10 2). It was the part of the priests to sound an alarm with the trumpets (2 Ch 13 12-16; cf 1 Macc 4 40; 16 8), and the trumpets were to be blown in time of battle to keep God in remembrance of Israel that they might gain the victory. In the Prophets, we find the commencement of war described as the drawing of the sword from its sheath (Ezk 21 3 ff), and the uncovering of the shield (Isa 22 6). Graphic pictures of the mobilizing of forces, both for invasion and for defence, are found in Isa (22 6-8) and Nah (3 2) and other Prophets. It was in the springtime that campaigns were usually opened, or resumed after a cessation of hostilities in winter (2 S 11 1; 1 K 20 22.26).

Of the actual disposition of troops in battle there are no full accounts till the Maccabean time, but an

examination of the Bib. battlefields by modern travelers with knowledge of military history has yielded valuable results in showing the position of the combatants and the progress of the

fight (an excellent example in Dr. William Miller's *Least of All Lands*, 85 ff, 116 ff, 150 ff, where the battles of Michmash, Elah and Gilboa are described with plans). With the Israelites the order of battle was simple. The force was drawn up, either in line, or in three divisions, a center and two wings. There was a rearguard (called in AV "rereward," in RV "rearward") to give protection on the march or to bring in stragglers (Jgs 7 16; 1 S 11 11; 2 S 18 2; 1 Macc 5 33; cf also Nu 10 25; Josh 6 9; 1 S 29 2; Isa 58 8). The signal for the charge and the retreat was given by sound of trumpet. There was a battle-cry to inspire courage and to impart confidence (Jgs 7 20; Am 1 14, etc). The issue of the battle depended upon the personal courage and endurance of the combatants, fighting man against man, but there were occasions when the

decision was left to single combat, as at the battle of Elah between the giant Goliath and the stripling David (1 S 17). The combat at Gibeon between the men of Benjamin, twelve in number, followers of Ish-bosheth, and twelve of the servants of David, in which each slew his man and all fell together by mutual slaughter, was the prelude to "a very sore battle" in which Abner and the men of Israel were beaten before the servants of David (2 S 2 16).

To the minor operations of war belong the raid, such as the Philis made into the Valley of Rephaim (1 Ch 14 9), the foray, the object of which was plunder (2 S 3 22), the foraging to secure supplies (2 S 23 11 m), and the movements of bands who captured defenceless inhabitants and sold them as slaves (2 K 5 2).

Of strategical movements in war there was the ambush with liers-in-wait resorted to by Joshua at Ai (Josh 8 3 ff); the feint, resorted to by the Israelites against the tribe of Benjamin (Jgs 20 20 ff); the flank movement, adopted by David in the Valley of Rephaim to rout the Philis (2 S 5 22 f); and the surprise, inflicted successfully at the Waters of Merom upon the Canaanites under Jabin by Joshua (Josh 11 1 f). Of all these the story of Judas Maccabaeus, the great military leader of the Jewish nation, furnishes illustrations (1 Macc 4 5 and elsewhere).

Among the requisites for the proper conduct of war the most important was the camp (*mahāneh*).

Of the exact configuration of the camp

of the Israelites, it is not possible to speak with certainty. The camp of Israel in the wilderness seems to have been quadrilateral, although some have supposed it to be round or triangular (Nu 2 1 ff). The camp in the wilderness was furnished with

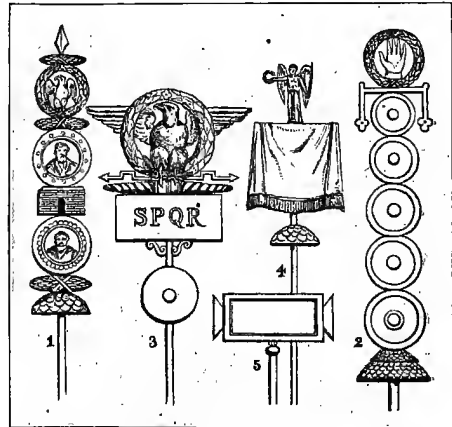

Roman Standards or Banners.  
From Montfaucon (1, 2). Hope (3, 4). Arch of Titus (5).

ensigns and standards—the family ensign (*’oth*), and a standard (*deghel*) for the group of tribes occupying each of the four sides. The standard or banner (*nēs*) is used of the signal for the mustering of troops, but standard-bearer, which occurs only once in the Bible, is a doubtful reading (Isa 10 18, where RVm, "sick man," is rather to be followed). In time of war the camp was surrounded by a barricade, or wagon-rampart (*ma’gāl*), as at Elah (1 S 17 20); and Saul lay within such a barricade in the wilderness of Ziph with his people round about him when David surprised him and carried off his spear (1 S 26 5 ff). Tents were used for the shelter of troops, at any rate when

occupied with a siege (2 K 7 7), although at the siege of Rabbah we read of booths for the purpose (2 S 11 11). Pickets were set to watch the camp, and the watch was changed three times in the course of the night (Jgs 7 19; 1 Macc 12 27). It was usual to leave a guard in charge of the camp when the force went into action or went off upon a raid (1 S 25 13; 30 10). Careful prescriptions were laid down for the preservation of the purity of the camp, "for Jeh thy God walketh in the midst of thy camp, . . . therefore shall thy camp be holy" (Dt 23 9-14; cf Nu 5 1-4).

Garrisons (*maçabbh*) were placed in occupation of fortresses and strategical centers (2 Ch 17 2). No doubt the caves in the hillsides and rocky fastnesses of the land, as at Michmash, would serve for their reception (1 S 13). The garrisons, however, which are expressly mentioned, were for the most part military posts for the occupation of a subject country—Philis in Israelitish territory (1 S 13 23; 14 1.11), and Israelites in Syrian and Edomite territory (2 S 8 6.14).

Among the characteristic notes of war, the tumult and the shouting were often noticed by the sacred historians (1 S 4 6; 14 19; 2 K 7 6).

**6. Characteristics** of the prophets the terrors and horrors and devastation of war are set forth in lurid colors. "The snorting of his horses is heard from Dan," is Jeremiah's description of an invading army, "at the sound of the neighing of his strong ones the whole land trembleth" (Jer 8 16). "The crack of the whip and the noise of the rumbling wheel and the galloping horse, and the jolting chariot and the rearing horsemen; and the flash of the sword and the glitter of the spear, and the multitude of slain; and a mass of dead bodies and no end to the carcases" (Nah 3 2-4; J. M. P. Smith's tr in ICC). Because of the devastation of territory and the slaughter of men which it entails, the sword is named with famine and "noisome beasts" (ARV has "evil beasts") and "pestilence" as one of God's "four sore judgments" (Ezk 14 21 AV). By a familiar figure "the sword" is often taken for all the operations of war, because it is characteristic of it to devour and to destroy (2 S 2 26; Jer 2 30).

While the treatment of the vanquished in the wars of Israel never reached the pitch of savagery common in Assyrian warfare, there are

**7. Defeat and Victory** not wanting examples of excessive severity, such as David's treatment of his Moabite prisoners (2 S 8 2) and of the Ammonites captured at Rabbah (2 S 12 31), and Menahem's barbarous treatment of Tiphshah (2 K 15 16; cf Nu 31 17; Josh 6 21). That it was common for the Philis to mutilate and abuse their prisoners is shown by Saul's determination not to fall into their hands (1 S 31 4). On that occasion the Philis not only stripped the slain, but cut off Saul's head and fixed his body to the wall of Bethshan (1 S 31 9.10). It was usual to carry off prisoners and sell them as slaves (2 K 5 2; 1 Macc 3 41). The conquerors were wont to deport the population of the subjugated country (2 K 17 6), to carry off treasure and impose tribute (2 K 16 8), and even to take the gods into captivity (Isa 46 1). On the other hand, the victors were hailed with acclamations and songs of rejoicing (1 S 18 6), and victory was celebrated with public thanksgivings (Ex 15 1; Jgs 5 1; 1 Macc 4 24).

The spoils of war, spoken of as booty also—armor, clothing, jewelry, money, captives and animals—falling to the victors, were divided equally between those who had taken part in the battle and those who had been left behind in camp (Nu 31 27; Josh 22 8; 1 S 30 24 f). A proportion

of the spoils was reserved for the Levites, and "a tribute unto the Lord" was also levied before

distribution was made of the collected booty (Nu 31 28.30). To the Lord, in the Israelitish interpretation of war, the spoils truly belong, and we see this exemplified at the capture of Jericho when the silver and the gold and the vessels of brass were put into the treasury of the house of the Lord (Josh 6 24). Under the monarchy, part of the spoils fell to the king who might in turn dedicate it to the Lord or use it for the purposes of war (2 K 14 14; 1 Ch 18 7.11). The armor of the conquered was sometimes dedicated as a trophy of victory and placed in the temple of the heathen or preserved near the ark of God (1 S 21 9; 31 9).

As the blast of the war-horn summoned to war, so it intimated the cessation of hostilities (2 S 2 28); and as to draw the sword was

**9. Treaties of Peace** the token of the entrance upon a campaign, so to return it to its sheath, or to put it up into the scabbard, was

emblematic of the establishment of peace (Jer 47 6). As ambassadors were sent to summon to war (Jer 49 14), or to dissuade from war (2 Ch 35 21), so ambassadors were employed to negotiate peace (Isa 33 7). Treaties of peace were made on occasion between combatants, as between Ahab and Ben-hadad II after the defeat of the latter and his fortunate escape from the hands of Ahab with his life (1 K 20 30.31). By the appeal of Ben-hadad's representative to Ahab's clemency his life was spared, and in return therefor he granted to Ahab the right to have bazaars for trade in Damascus as his father had had in Samaria (1 K 20 34). Alliances, offensive and defensive, were common, as Ahab and Jehoshaphat against Syria (1 K 22 2 ff), Jehoram and Jehoshaphat and the king of Edom against Moab (2 K 3 7 ff), and the kings of the West, including Ahab and Hadadezer of Damascus, to resist Shalmaneser II of Assyria, who routed the allies at the battle of Karkar in 854 BC. It is among the wonderful works of Jeh that He makes war to cease to the end of the earth, that He breaks the bow, and cuts the spear in sunder, and "burneth the chariots in the fire" (Ps 46 9). And prophetic pictures of the peace of the latter days include the breaking of "the bow and the sword and the battle out of the land" (Hos 2 18), the beating of "swords into plowshares, and . . . spears into pruning-hooks" (Isa 2 4; Mic 4 3).

Among the signs of the last days given by Our Lord are "wars and rumors of wars" (Mt 24 6; Mk 13 7; Lk 21 9; 21 24). Jesus

**10. War in the NT** accepts war as part of the present world-order, and draws from it an impressive illustration of the exacting conditions of Christian discipleship (Lk 14 31 ff). He foresees how Jerus is to be encompassed with armies and devoted to the bitterest extremities of war (Lk 19 41 ff). He conceives Himself come, not to send peace on earth, but a sword (Mt 10 34); and declares that they who take the sword shall perish by the sword (Mt 26 52). The apostles trace war to the selfishness and greed of men (Jas 4 1 ff); they see, speaking figuratively, in fleshly lusts enemies which war against the soul (1 Pet 2 11); they find in war apt figures of the spiritual struggle and Divine protection and ultimate victory of the Christian (Rom 7 23; 8 37; 2 Cor 10 3.5; 1 Tim 1 18; He 13 13; 1 Pet 1 5), and of the triumphs of Christ Himself (2 Cor 2 14; Col 2 15; Eph 2 16.17). St. Paul made the acquaintance of the barracks, both at Jerus and at Caesarea (Acts 21 34.37; 23 35); and at Rome his bonds became familiar to the members of the Prætorian guard who were from time to time detailed to have

him in keeping (Phil 1 13). It is under the figures of battle and war that St. John in the Apocalypse conceives the age-long conflict between righteousness and sin, Christ and Satan, and the final triumph of the Lamb, who is King of kings, and Lord of lords (Rev 16 14-16; 17 14; 19 14). For other references see ARMY, 9; PRÆTORIAN GUARD; TREATY.

LITERATURE.—Benzinger, art. "Kriegswesen" in Herzog, *RE*<sup>3</sup>, XI; Nowack, *Hebräische Archaeologie*, 72; Browne, *Heb Antiquities*, 44-47.

T. NICOL

**WAR, MAN OF** (אִישׁ מִלְחָמָה, *ish milhāmāh*):

"Jehovah is a man of war:  
Jehovah is his name" (Ex 15 3).

In early Israel the character of Jeh as the *war-God* forms a prominent feature in the conception of God (Nu 10 35; 21 14; Josh 5 13; 10 11; Jgs 5 4.13. 20.23.31, etc). See GOD, NAMES OF, III, 8; LORD OF HOSTS; and *HDB*, V, 635 ff.

**WARD**, wôrd: "Ward" and "guard" are two different spellings of the same word, and in consequence no clear line can be drawn between them. EV, however, has used "guard" only in the sense of "a special body of soldiers" (Gen 37 36, etc), while "ward" is used, not only in this sense (Jer 37 13; contrast 39 9), but also in a variety of others. So a "ward" may mean "any body of men on special duty" as 1 Ch 9 23; AV 1 Ch 26 16; Neh 12 24.25 (RV "watch"), or the duty itself, as Isa 21 8; 1 Ch 12 29 AV (RV "allegiance"); 25 8; 26 12 (RV "office," m "ward"); Neh 12 45; 13 30 (RV "charge"). Or "ward" may mean "guarded place," always in the phrase "put in ward." RV has kept this phrase throughout (Gen 40 3, etc), changing it only in Ezk 19 9, where "cage" better carries out the figure of the context.

The distinction of the older Eng. between "watch" and "ward," as applying respectively to the night and to the day seems unknown in EV. Cf Isa 21 8.

The affix "ward," denoting direction and still used in such forms as "toward," "northward," etc, had a much wider range in Bib. Eng. So "to God-ward" (Ex 18 19; 2 Cor 3 4; 1 Thess 1 8); "to thee-ward" (1 S 19 4); "to us-ward" (Ps 40 5; Eph 1 19; 2 Pet 3 9 AV); "to you-ward" (2 Cor 1 12; 13 3; Eph 3 2; 2 Pet 3 9 RV); and in Ex 37 9, AV "even to the mercy seatward" (RV "toward the mercy-seat").

BURTON SCOTT EASTON

**WARES**, wârz (מִקְחָה, *makkāhāh*, מֶכֶר, *mekher*, מִמְכָר, *mimkār*, קִנְיָה, *kin'āh*, מַעֲשֵׂה, *ma'āseh*, עֲבָדוֹת, *'izzābhōn*, קָלִי, *kālī*): (1) *makkāhāh*, something received or purchased (Neh 10 31); (2) *mekher*, "price" or "pay," value, merchandise (Neh 13 16); (3) *mimkār*, a "selling," the thing sold (Neh 13 20); (4) *kin'āh*, a "package," hence wares (Jer 10 17); (5) *ma'āseh*, "transaction," activity, property, possession, work, occupation, thing made, deed, business (Ezk 27 16.18); (6) *'izzābhōn*, "selling," trade, revenue, mart, letting go for a price (Ezk 27 33); (7) *kālī*, a "prepared" something, as an implement, tool, weapon, utensil, armor, furniture, sack, vessel, hence wares (Jon 1 5). In most cases the real sense is merchandise (see MERCHANDISE). "That which did not a little amuse the Merchandizers [in Vanity-Fair] was, that these Pilgrims set very light by all their Wares; they cared not so much as to look upon them" (Bunyan, *The Pilgrim's Progress*).

WILLIAM EDWARD RAFFETY

**WARFARE**. See WAR, WARFARE.

**WARP**, wôrp (שֵׁרֵץ, *shēthī* [Lev 13 48-59]): The long threads fixed into the loom to form the basis of the web, and into which the wool is wrought from the shuttle. The warp and the wool lying at

right angles to one another have in their Heb form (*shēthī w'ērebh*) given to modern Jewish speech a secret expression to designate the cross. See WEAVING.

**WARS, wôrz, OF JEHOVAH (THE LORD), BOOK OF THE.** See BIBLE, IV, 1, (1), (b).

**WASH**, wosh, **WASHING**, wosh'ing: The two usual Heb words for "wash" are רָחַץ, *rāhaç*, and כָּבַח, *kābhaç*, the former being normally used of persons or of sacrificial animals (Gen 18 4, etc, often tr<sup>d</sup> "bathe"; Lev 15 5, etc), and the latter of things (Gen 49 11, etc), the exceptions to this distinction being few (for *rāhaç*, 1 K 22 38 m; for *kābhaç*, Ps 51 2.7; Jer 2 22; 4 14). Much less common are דָּוַח, *dū'ah* (2 Ch 4 6; Isa 4 4; Ezk 40 38) and שָׁטַף, *shā'taph* (1 K 22 38; Job 14 19; Ezk 16 9), tr<sup>d</sup> "rinse" in Lev 6 28; 15 11.12. In Neh 4 23 AV has "washing" and RV "water" for *mayim*, but the text is hopelessly obscure (cf RVm). In the Apoc and NT the range of terms is wider. Most common is *νίρω*, *nīplō* (Mt 6 17, etc), with *ἀπονίπλω* in Mt 27 24. Of the other terms, *λούω*, *louō* (Sus vs 15.17; Jn 13 10, etc), with *ἀπολούō* (Acts 22 16; 1 Cor 6 11) and the noun *λουτρόν* (Sir 34 25b; Eph 5 26; Tit 3 5), usually has a sacral significance. On βαπτίζω, *baptizō* (Sir 34 25a; Mk 7 4; Lk 11 38), with the noun *βαπτισμός* (Mk 7 4 [text?]; He 9 10), see BAPTISM. In Lk 5 2; Rev 7 14; 22 14 RV occurs *πλύνω*, *plūnō*, while Jth 10 3 has *περικλύζω*, *periklūzō*. Virtually, as far as meaning is concerned, all these words are interchangeable. Of the figurative uses of washing, the most common and obvious is that of cleansing from sin (Ps 51 2; Isa 1 16, etc), but, with an entirely different figure, "to wash in" may signify "to enjoy in plenty" (Gen 49 11; Job 29 6; the meaning in Cant 5 12 is uncertain). Washing of the hands, in token of innocence, is found in Dt 21 6; Mt 27 24.

The "washing balls" of Sus ver 17 (σμήγμα, *smēgma*, a very rare word) were of soap. See SOAP.

BURTON SCOTT EASTON

**WASHING OF FEET**: The OT references (Gen 18 4; 19 2; 24 32; 43 24; Jgs 19 21; 1 S 25 41; 2 S 11 8; Cant 5 3; Ps 58 10) show that the washing of the feet was the first act on entering the tent or house after a journey. The Orientals wore only sandals, and this washing was refreshing as well as cleanly. In the case of ordinary people, the host furnished the water, and the guests washed their own feet, but in the richer houses, the washing was done by a slave. It was looked upon as the lowliest of all services (1 S 25 41). Jesus pointedly contrasts Simon's neglect of even giving Him water for His feet with the woman's washing His feet with tears and wiping them with her hair (Lk 7 44). On the last evening of His life, Jesus washed the disciples' feet (Jn 13 1-16). Their pride, heightened by the anticipations of place in the Messianic kingdom whose crisis they immediately expected, prevented their doing this service for each other. Possibly the same pride had expressed itself on this same evening in a controversy about places at table. Jesus, conscious of His Divine dignity and against Peter's protest, performed for them this lowliest service. His act of humility actually cleansed their hearts of selfish ambition, killed their pride, and taught them the lesson of love. See also *Expos T*, XI, 536 f.

Was it meant to be a perpetual ordinance? Jn 13 15, with its "as" and the present tense of the vb. "do," gives it a priori probability. It has been so understood by the Mennonites and the Dunkards. Bernard of Clairvaux advocated making it a sacra-

ment. The Pope, the Czar, and the Patriarch of Constantinople wash the feet of 12 poor men on Maundy Thursday; so did the Eng. kings till James II, and it is still practised in the royal palaces of Madrid, Munich and Vienna. But the objections to such an interpretation are overwhelming: (1) It is never referred to in the Synoptic Gospels, the Acts or the Epp.; 1 Tim 5 10 refers only to lowly service to the saints. (2) It was first in the 4th cent. (cf Ambrose and Augustine) that it became the custom to wash the feet of the baptized on Maundy Thursday. (3) Ritualizing such an act of love absolutely destroys its meaning. (4) No large body of Christians has ever received it as a sacrament or an ordinance. F. L. ANDERSON

ACCORDING TO THE BELIEF AND PRACTICE OF THE CHURCH OF THE BRETHREN

Feet-washing is always practised in connection with the Agape and Eucharist. This entire service is usually called "Love Feast." These

**1. Practice** Love Feasts are always held in the evening (in conformity to the time of Jesus' Last Supper). Preparatory services on self-examination are held either at a previous service or at the opening of the Love Feast. Each church or congregation is supposed to hold one or two Love Feasts annually. No specified time of the year is set for these services. Before the supper is eaten all the communicants wash one another's feet; the brethren by themselves, and likewise the sisters by themselves.

(1) *The mode.*—In earlier years the "Double Mode" was practised, where one person would wash the feet of several persons and another would follow after and wipe them. At present the "Single Mode" is almost universal, wherein each communicant washes and wipes the feet of another. Hence each one washes and wipes the feet of another, and in turn has this same service performed to himself.

(2) *The salutation.*—Feet-washing is also accompanied with the "Holy Kiss." As soon as one has finished washing and wiping the feet of another, he takes him by the hand and greets him with the "holy kiss," usually with an appropriate benediction as: "God bless you," or "May the Lord bless us."

There are three texts in the NT referring to feet-washing (Lk 7 36-50; Jn 13 1-17; 1 Tim 5 10).

(1) *Jesus washing the disciples' feet* **2. Scriptural Basis for Feet-Washing** (Jn 13 1-17).—"At supper time" (*δευτέρα του γενομένου, δευτέρου γενομένου*) Jesus arose, laid aside His garments (*ἱμάτια, himátia*—"outer garments"), girded Himself with a towel, poured water into a basin, and began to wash and wipe the feet of the disciples.

(2) *Peter's objection.*—"Simon Peter . . . saith unto him, Lord, dost thou wash my feet [*σὺ μου νίπτεις τοὺς πόδας, σύ μου nípteis toús pódas*]? Jesus answered . . . What I do thou knowest not now; but thou shalt understand hereafter. Peter saith unto him, Thou shalt never wash my feet." Whereupon Jesus said: "If I wash thee not, thou hast no part with me."

(3) *Jesus explains.*—Peter now goes to the other extreme and desires complete washing. Jesus answers "He that is bathed (*λαλουμένος, lelouménos*, from *λούω, lóō*, "to bathe the entire body") needeth not save to wash [*νίπτειν, níptein*—"to wash a part of the body"] his feet." Jesus was not instituting a new symbol to take the place of baptism, to cleanse the entire person, but clearly distinguishes between the bathing (*λουῶ*) of the entire body and the partial cleansing needed after the bath (baptism or immersion).

(4) *The command.*—"If I then, the Lord and the Teacher, have washed your feet, ye also ought to wash one another's feet" (ver 14, *καὶ ὑμεῖς ὀφείλετε ἀλλήλων νίπτειν τοὺς πόδας, καὶ ἡμεῖς οφείλετε ἀλλήλων níptein toús pódas*), "I have given you an example [sign, symbol, *ὑπόδειγμα, hypódeigma*], that ye also should do as I have done to you" (ver 15). "If ye know these things, happy [or "blessed" RV, *μακάριοι, makáριοι*] are ye if ye do them" (*εἰὰν ποιῆτε αὐτά, εὐὰν ποιῆτε αὐτά*). No language is clearer, and no command of Jesus is stronger than this. Furthermore, no symbol is accompanied with a greater promise. Note also, "If I wash thee not, thou hast no part with me."

(1) *Negatively.*—(a) It cannot be explained as necessity or custom, i.e. that the dust must be washed from the feet of the disciples before proceeding with the supper. It was so cold that Peter had to warm himself, and this is sufficient evidence that they wore shoes instead of sandals at this time. Furthermore, Peter did not understand the action of Jesus, hence it could not have been customary. Most of all, Jesus was not scrupulous about keeping the customs or practices of the Jews; cf Jesus' breaking of the Jewish Sabbath (Mk 2 23-26); the Jewish fasts (Mk 2 18-22); the Jewish cleansings (Mk 7 1-20). (b) It was not customary for the host to wash the feet of the guests. Peter objected, and Jesus told him distinctly that he could not understand at the time (*ἀπὸ, ápti*) but would afterward (*μετὰ ταῦτα, metá taúta*). The symbol had a deeper meaning.

**3. The Meaning Symbol**

(2) *Positively.*—(a) Feet-washing symbolizes humility and service. The apostles had been quarreling as to who would be greatest in the kingdom which they thought Jesus was about to set up (Lk 22 24-30). Most authorities agree that this quarrel took place before the supper. Peter's question, "Dost thou wash my feet?" shows clearly that his objection lay principally in this, that the Lord and Master should perform such a humble service. But Jesus was trying all the time to teach His disciples that true greatness in His kingdom is *humility and service*. "I am in the midst of you as he that serveth" (Lk 22 27; cf Mt 5 5; 23 11,12). Humility and service are fundamental virtues in the Christian life. To wash the feet of another symbolizes these virtues in the same way that the Eucharist symbolizes other Christian virtues. (b) Cleansing: Jesus clearly distinguished between the first cleansing which cleanses the whole person, and the washing of a part of the body. Baptism is the new birth, which means a complete cleansing. But after baptism we still commit sins, and need the partial cleansing as symbolized by feet-washing. Cf Bernard of Clairvaux: "Feet-washing is a cleansing of those daily offences which seem inevitable for those who walk in the dust of the world" (*sed pedes [abluti sunt] qui sunt animae affectiones, dum in hac pulvere gradimur, ex toto mundi esse non possunt*).

Feet-washing is practised by the Church of the Brethren for the following reasons: (1) Jesus washed His disciples' feet and said, "I have given you an example, that ye also should do as I have done to you" (Jn 13 15). (2) Jesus said, "Ye also ought of [ "are bound," *οφείλετε*] to wash one another's feet" (ver 14). (3) "If I wash thee not, thou hast no part with me" (ver 8). (4) "If ye know these things, blessed are ye if ye do them" (ver 17). (5) Feet-washing symbolizes humility and service, which are fundamental virtues. (6) Feet-washing symbolizes cleansing from the sins committed after baptism.

**4. Practised** given you an example, that ye also should do as I have done to you" (Jn 13 15). (2) Jesus said, "Ye also ought of [ "are bound," *οφείλετε*] to wash one another's feet" (ver 14). (3) "If I wash thee not, thou hast no part with me" (ver 8). (4) "If ye know these things, blessed are ye if ye do them" (ver 17). (5) Feet-washing symbolizes humility and service, which are fundamental virtues. (6) Feet-washing symbolizes cleansing from the sins committed after baptism.

**LITERATURE.**—For the Church of the Brethren: C. F. Yoder, *God's Means of Grace*; R. H. Miller, *The Doctrine of the Brethren Defended*; tracts issued by the Brethren Publishing House, Elgin, Ill. For history of feet-washing, see *ERE, V: New Sch-Herz Enc of Religious Knowledge*, IV, 4; Smith and Cheetham, *Dict. of Christian Antiquities*, arts. "Baptism," "Maundy Thursday."

DANIEL WEBSTER KURTZ

**WASHPOT**, wosh'pot (וַיִּץ קִיר, *šir rahas*, "vessel for washing"): Only Ps 60 8=108 9, "Moab is my washpot"; i.e. "Moab is my chattel, to be treated contemptuously," as the vessel in which the conqueror's feet are washed.

**WASP**, wosp. See **HORNET**.

**WATCH**, woch (אַשְׁמֹרֶת, 'ashmōrēth; φυλακή, *phulakē*): A division of the night. The night was originally divided into three watches (Jgs 7 19), but later into four, as we find in the NT (Mt 14 25; Mk 6 48). We do not know the limits of the watches in the first division, but the middle watch probably began two hours before midnight and ended two hours after. The fourfold division was according to the Rom system, each of which was a fourth part of the night. See TIME.

"Watch" is also the guard placed on watch (מִשְׁמָרָה, *mishmār*, Neh 4 9; *κουστώδια*, *koustōdia*, from Lat *custodia*, Mt 27 65.66; 28 11). It sometimes refers to the act of watching, as in 2 K 11 6.7 (מִשְׁמָרָה, *mishmereth*); Lk 2 8 (*phulakē*).

"Watch" is also used figuratively, as in Ps 141 3 for *restraint*: "Set a watch, O Jeh, before my mouth" (שְׁמָרָה, *shomrāh*). See WARD. H. PORTER

**WATCHER**, woch'er (Aram. עִיר, 'ir, "wakeful one"): In Nebuchadnezzar's dream (Dnl 4 13.17. 23 [MT 10.14.20]) a messenger who with "a holy one" descended from heaven, they having joint authority to issue decrees. In the apocryphal literature the doctrine of the "watchers" is much elaborated. In Jub they are regarded as angels sent to instruct mankind in righteousness. In En they sometimes appear as archangels and at other times as fallen angels. In the latter condition only we find them in the Book of Adam and Eve. The place of descent was according to En 6 6 the summit of Mt. Hermon. W. M. CHRISTIE

**WATCHMAN**, woch'man (צֹפֵה, *cōpheh*, שָׂמֵר, *shōmēr*, מִצְפֵּה, *m'cappēh*, נָצֵר, *nōcēr*): Used to designate a sentinel on the city walls (2 S 18 25; 2 K 9 18; Ps 127 1; Isa 62 6) or on the hilltops (Jer 31 6). Cant 3 3; 5 7 introduces another class, "the watchmen that go about the city," and thus, it would seem, points to some system of municipal police. The distinction in meaning between the various words is clear, *cōpheh* having the idea of "outlooker" and *nōcēr* that of "careful watcher" (being applied even to besiegers from outside: Jer 4 16, "watchers"), while *shōmēr* also embraces the idea of "defending" or "guarding." In Isa 21 6 *m'cappēh* is to be taken generally in the sense of "watch." In Sir 37 14 *σκοπός*, *skopós*, means simply "looker." W. M. CHRISTIE

**WATCH-TOWER**, woch'tou-ēr (מִצְפֵּה, *micpēh* [Isa 21 8; 2 Ch 20 24]; בֵּהַר, *bāhar* [Isa 32 14 RV]): In Isa 2 16 the words *s'khūyōth ha-hemdāh* have puzzled the translators. AV gives "pleasant pictures," RV "pleasant imagery," while RVm has "pleasant watchtowers." Guthe in Kautzsch's Bible translates *Schaustücke*, which practically agrees with RV. See MIZPEH; TOWER.

**WATER**, wō'tēr (מַיִם, *mayim*; ὕδωρ, *hūdōr*):

(1) The Gr philosophers believed water to be the original substance and that all things were made from it. The Koran states, "From water we have made all things." In the story of the creation (Gen 1 2) water plays an elemental part.

(2) Because of the scarcity of water in Pal it is esp. appreciated by the people there. They love to go and sit by a stream of running water. Men long for a taste of the water of their native village (1 Ch 11 17). A town or village is known throughout the country for the quality of its water, which is described by many adjectives, such as "light," "heavy," etc.

(3) The rainfall is the only source of supply of water for Pal. The moisture is carried up from the

sea in clouds and falls on the hills as rain or snow. This supplies the springs and fountains. The rivers are mostly small and have little or no water in summer. For the most part springs supply the villages, but in case this is not sufficient, cisterns are used. Most of the rain falls on the western slopes of the mountains, and most of the springs are found there. The limestone in many places does not hold the water, so wells are not very common, though there are many references to them in the Bible.

(4) Cisterns are usually on the surface of the ground and vary greatly in size. Jerus has always had to depend for the most part on water stored in this way, and carried to the city in aqueducts. A large number of cisterns have been found and partially explored under the temple-area itself. The water stored in the cisterns is surface water, and is a great menace to the health of the people. During the long, dry summer the water gets less and less, and becomes so stagnant and filthy that it is not fit to drink. In a few instances the cisterns or pools are sufficiently large to supply water for limited irrigation. See CISTERN.

(5) During the summer when there is no rain, vegetation is greatly helped by the heavy dews. A considerable amount of irrigation is carried on in the country where there is sufficient water in the fountains and springs for the purpose. There was doubtless much more of it in the Rom period. Most of the fruit trees require water during the summer.

(6) Many particular wells or pools are mentioned in the Bible, as: Beersheba (Gen 21 19), Isaac's well (Gen 24 11), Jacob's well (Jn 4 6), Pool of Siloam (Jn 9 7), "waters of Nephtoah" (Josh 15 9).

(7) Washing with water held a considerable place in the Jewish temple-ceremony (Lev 11 32; 16 4; 17 15; 22 6; Nu 19 7; Ex 30 18; 40 7). Sacrifices were washed (Ex 29 4; Lev 1 9; 6 28; 14 5).

(8) The lack of water caused great suffering (Ex 15 22; Dt 8 15; 2 K 3 9; Ps 63 1; Prov 9 17; Ezk 4 11; Lam 5 4). See also FOUNTAIN; PIT; POOL; SPRING; WELL. ALFRED H. JOY

**WATER OF BITTERNESS (OR OF JEALOUSY)**. See ADULTERY, (2).

**WATER OF SEPARATION (OR OF UNCLEANNESS)**. See DEFILEMENT; SEPARATION; UNCLEANNESS.

**WATERCOURSE**, wō'tēr-kōrs: (1) אֵפְיֵק, *'āphēk* (Ezk 6 3; 31 12; 32 6; 34 13; 35 8; 36 4.6), AV "river," elsewhere "stream," "channel," or "brook." (2) פֶּלֶגַי, *pelegh* (Prov 21 1). "The king's heart is in the hand of Jeh as the water-courses," AV "rivers," elsewhere "streams" or "rivers." (3) יַבְהֵל, *yābhāl*, מַיִם, *mayim*, יַבְהֵלֵי מַיִם, *yibhēley mayim*, "watercourses" (EV) (Isa 44 4); in Isa 30 25, EV has "streams of water"; cf יַבְהֵל, *yābhāl*, "rivers" (Jer 17 8); יַבְהֵל, *yābhāl*, "Jubal" (Gen 4 21); אֲבָחַל, *'ābhal*, "the river Ulai" (Dnl 8 2.3.6). (4) תְּעֻלָּה, *t'eālāh*, "channel," AV "watercourse" (Job 38 25); elsewhere "conduit," "the conduit of the upper pool" (2 K 18 17; Isa 7 3; 36 2). (5) צִנּוֹר, *çinnōr*, "watercourse," AV "gutter" (2 S 5 8). See BROOK; RIVER; STREAM; WATERFALL.

ALFRED ELY DAY  
**WATERFALL**, wō'tēr-fōl (צִנּוֹר, *çinnōr*; only in ARV [Ps 42 7]):

"Deep calleth unto deep at the noise of thy waterfalls; All thy waves and thy billows are gone over me."

AV and ERV have "waterspouts," ERV<sup>m</sup> "cata-racts." The etymology of the word is uncertain.



A VENDOR OF WATER





It occurs also in 2 S 5 8, tr<sup>d</sup> "watercourse," AV "gutter." Cf צַנְתֹּרוֹת, *can't-rōth*, "spouts" (Zec 4 12).

**WATERPOT**, wō'tēr-pot (ὕδρια, *hudria*; cf ὕδωρ, *hūdōr*, "water"): An earthen vessel, or jar, for carrying or holding water (in LXX for כַּד, *kadh*,



Eastern Waterpots.

"jar," or "pitcher"). It was usually carried by women upon the head, or upon the shoulder (Jn 4 28). Pots of larger size, holding eighteen or twenty gallons apiece, were used by the Jews for purposes of ceremonial purification (Jn 2 6).

**WATERS**, wō'tēr (מַיִם, *mayim*, pl. of \*מַי, *may*, "water"; in the NT ὕδωρ, *hūdōr*, "water"; κινδύνους ποταμῶν, *kindúnous potamōn* [2 Cor 11 26], AV "perils of waters," is in RV "perils of rivers"): In the NT there is frequent reference to the water of baptism. Pilate washes his hands with water to signify his guiltlessness. Jesus tells the Sam woman of the living water. The Lamb shall guide the redeemed unto fountains of waters of life.

The uses of *mayim* are well classified in *BDB*, esp. the figurative references, as follows: a symbol of distress, "when thou passest through the waters" (Isa 43 2); of force, "like the breach of waters" (2 S 5 20); of that which is overwhelming, "a tempest of mighty waters overflowing" (Isa 28 2); of fear, "The hearts of the people . . . became as water" (Josh 7 5); of transitoriness, "Thou shalt remember it as waters that are passed away" (Job 11 16); of refreshment, "as streams of water in a dry place" (Isa 32 2); of peace, "He leadeth me beside still waters" (Ps 23 2); of legitimate pleasures, "waters out of thine own cistern" (Prov 5 15); of illegitimate pleasures, "Stolen waters are sweet" (Prov 9 17); of that which is poured out abundantly, blood (Ps 79 3), wrath (Hos 5 10), justice (Am 5 24), groanings (Job 3 24).

ALFRED ELY DAY

**WATERS OF MEROM**. See MEROM, WATERS OF.

**WATERS OF STRIFE**, strif. See MERIBAH.

**WATERPOUT**, wō'tēr-spout: (1) צַנְתֹּר, *can'tōr* (Ps 42 7), ARV "waterfalls," AV and ERV "water-spouts," ERV<sup>m</sup> "cataracts." (2) תַּנְיִן, *tannīn* (Ps 148 7), ARV "sea-monsters," AV and ERV

"dragons," ERV<sup>m</sup> "sea-monsters" or "water-spouts."

"Praise Jeh from the earth,  
Ye sea-monsters, and all deeps."

See DRAGON; SEA-MONSTER; WATERFALL.

ALFRED ELY DAY

**WAVE OFFERING**, wāv of'ēr-ing. See SACRIFICE IN THE OT.

**WAW**, waw (ו): The sixth letter of the Heb alphabet; transliterated in this Encyclopaedia *w* (or *v*). It came also to be used for the number 6. For name, etc, see ALPHABET.

**WAX**, waks:

(1) Noun (דֹּבַח, *dōnagh*): Used only in a simile of melting (Ps 22 14; 68 2; 97 5; Mic 1 4). But see WRITING.

(2) A now archaic vb., meaning "to grow," used freely in EV as a tr of various terms in Gr and Heb. The past participle in AV and ERV is "waxen" except in Gen 18 12. There (and throughout in ARV) the form is "waxed."

**WAY**, wā (אֲרָץ, 'orah, אֲרָהָה, 'orhā, אֶרֶץ, 'ereṣ, בֹּרַח, bō', דֶּרֶךְ, derekh, הַדְּלִיקָה, hādīkkeh, מַעְגָּלָה, ma'gālāh, נָתִיב, nāthībh; ὁδός, hodós, πάροδος, párodos, πορεία, poréia, τρόπος, trópos; "highway," מִסְלָה, m'sullāh, מַסְלֵל, maslāl; διεξόδου τῶν ὁδῶν, diexōdoi tōn hodōn): The list just cited contains only a portion of the words tr<sup>d</sup> "way" or "highway" in AV. Most of them have the primary meaning of "road," "customary path," "course of travel" (Gen 3 24; Ex 23 20; Nu 20 17, etc). By a very easy and natural figure "way" is applied to the course of human conduct, the manner of life which one lives (Ex 18 20; 32 8; Nu 22 32; 1 S 8 3; 1 K 13 33, etc; Acts 14 16; 1 Cor 4 17; Jas 5 20). "The way of an eagle . . . of a serpent . . . of a ship . . . and of a man" (Prov 30 19) agree in that they leave no trace behind them (cf Wisd 5 10.11). In some cases the language may be such as to leave it indeterminate whether the way or course of conduct is good or bad (Dt 28 29; 1 S 18 14; 2 Ch 27 7; Job 13 15; Prov 3 6; 6 6; Jas 1 8), though in most cases the Bible writers attach to every act an ethical evaluation. Sometimes this way of conduct is of purely human choice, without reference to either God or good (Jgs 2 19; Job 22 15; 34 21; Ps 119 9; Prov 12 15; 16 2). Such a course is evil (2 Ch 7 14; Ps 1 6; 119 101.104.128; Prov 1 19, etc) and will obtain such punishment as its lack of merit warrants (1 K 8 32.39; 2 Ch 6 23; Job 30 12; 34 11; Jer 17 10; Ezk 7 3.9; Hos 12 2). At the opposite extreme from this is the good way (Ps 1 6; Prov 8 20; 12 28; 15 10; Isa 26 7), which is that course of conduct enjoined by God and exemplified in His perfect conduct (Gen 6 12; 18 19; Dt 8 6; 26 17; 1 K 2 3; Job 23 11; Ps 51 13, etc). These two ways briefly but graphically described by the Lord (Mt 7 13.14; cf Lk 13 24) became the subject of extended catechetical instruction in the early church. See the Ep. of Barnabas, xviii, and the *Did.*, i.1. Frequently the way in this metaphorical sense is characterized by that quality which is its outstanding feature, e.g. mention is made of the way of life (Prov 15 24; Jer 21 8; Acts 2 28); of truth (Ps 119 30; 2 Pet 2 2); of peace (Isa 59 8; Lk 1 79; Rom 3 17); of justice (Prov 17 23; Dnl 4 37); of righteousness (Mt 21 32; 2 Pet 2 21); of salvation (Acts 16 17); of lying (Ps 119 29), and of death (Jer 21 8). Frequently God's purpose or His customary action is described as His way (Ps 103 7; Isa 26 8; Mt 22 16; Acts 13 10). Since all of God's plans and pur-

poses tend toward man's salvation, His provisions to this end are frequently spoken of as His Way, and inasmuch as all of the Divine plans center in Christ He is preëminently the Way (Jn 14 6). Out of this fact grew the title, "The Way," one of the earliest names applied to Christianity (Acts 9 2; 18 25,26; 19 9,23; 22 4; 24 22).

The word **highway** is used to denote a prominent road, such a one for example as was anciently maintained for royal travel and by royal authority. It is always used in the literal sense except in Prov 15 19; 16 17, where it is a course of conduct. See also **PATH, PATHWAY**. W. C. MORRO

**WAY, COVERED.** See **COVERED WAY**.

**WAY, LITTLE** (כִּבְרָה, *kibhrāh*, "length," "a measure"): A technical measure of distance in the Heb; but it must be considered undefined (Gen 35 16; 48 7 AV, ERV "some way," ARV "some distance"; 2 K 5 19, ERV "some way," ARVm "some distance"). The Heb term *kibhrāh* is also found in Phoen inscriptions as a measure of distance.

**WAYFARING**, wā'fār-ing, **MAN**: The tr in Jgs 19 17; 2 S 12 4; Jer 9 2; 14 8 of מַרְאֵה, 'ōrē'āh, the participle of 'ārah, "to journey." In Isa 33 8 of 'ōbhēr 'ōrah, "one passing on a path," and in Isa 35 8 of hōlēkh derekh, "one walking on a road." "Traveler" is the meaning in all cases.

**WAYMARK**, wā'mārk (צִיּוּן, *ṣiyūn*): In Jer 31 21, "Set thee up waymarks," explained by the parallel, "Make thee guide-posts" (AV "Make thee high heaps"). A sign or guiding mark on the highway.

**WEALTH**, welth, **WEALTHY**, wel'thi (הוֹן, *hōn*, הַיִּל, *hayil*, נִכְסִים, *n'khasīm*; εὐπορία, *euporia*, "to possess riches," "to be in a position of ease" [Jer 49 31]): The possession of wealth is not regarded as sinful, but, on the contrary, was looked upon as a sign of the blessing of God (Eccl 5 19; 6 2). The doctrine of "blessed are the poor, and cursed are the rich" finds no countenance in the Scriptures, for Lk 6 20,24 refers to concrete conditions (disciples and persecutors; note the "ye"). God is the maker of rich and poor alike (Prov 22 2). But while it is not sinful to be rich it is very dangerous, and certainly perilous to one's salvation (Mt 19 23). Of this fact the rich young ruler is a striking example (Lk 18 22,23). It is because of the danger of losing the soul through the possession of wealth that so many exhortations are found in the Scriptures aimed esp. at those who have an abundance of this world's goods (1 Tim 6 17; Jas 1 10,11; 5 1, etc). Certain parables are esp. worthy of note in this same connection, e.g. the Rich Fool (Lk 12 16-21), the Rich Man and Lazarus—if such can be called a parable—(Lk 16 19-31). That it is not impossible for men of wealth to be saved, however, is apparent from the narratives, in the Gospels, of such rich men as Nicodemus, and Joseph of Arimathaea (Jn 19 38,39; Mt 27 57-60), and Zacchaeus (Lk 19 1-10). It may fairly be inferred from the Gospel records that James and John, who were disciples of Our Lord, were men of considerable means (Mk 1 19, 20; Jn 19 27).

Wealth may be the result of industry (Prov 10 4), or the result of the special blessing of God (2 Ch 1 11,12). We are warned to be careful lest at any time we should say "My power and the might of my hand hath gotten me this wealth. But thou shalt remember Jeh thy God, for it is he that giveth thee power to get wealth" (Dt 8 17,18).

Those possessing wealth are liable to certain kinds of sins against which they are frequently warned, e.g., high-mindedness (1 Tim 6 17); oppression of the poor (Jas 2 6); selfishness (Lk 12 and 16); dishonesty (Lk 19 1-10); self-conceit (Prov 28 11); self-trust (Prov 18 11).

It is of interest to note that in the five places in the NT in which the word "lucre"—as applying to wealth—is used, it is prefaced by the word "filthy" (1 Tim 3 3 [AV]; Tit 1 7,11; 1 Pet 5 2), and that in four of these five places it refers to the income of ministers of the gospel, as though they were particularly susceptible of being led away by the influences and power of money, and so needed special warning.

The Scriptures are not without instruction as to how we may use our wealth wisely and as well-pleasing to God. The parable of the Unjust Steward (Lk 16) exhorts us to "make . . . friends by means of the mammon of unrighteousness" by which is meant that we should use the wealth which God has committed to us as stewards in order that we may win friends (souls) with it for Him and His kingdom, just as the unfaithful steward used the goods with which his master had intrusted him to make friends for himself. The parable of Dives and Lazarus gives us the sad picture of a selfish rich man who had abused his trust, who had failed to make friends with his money, and who, in the other world, would have given anything just for such a friend (Lk 16 19-31). See also **RICHES**. WILLIAM EVANS

**WEAN**, wēn: "To wean" in EV is always the tr of גָּמַל, *gāmal*, but *gāmal* has a much wider force than merely "to wean," signifying "to deal fully with," as in Ps 13 6, etc. Hence, as applied to a child, *gāmal* covers the whole period of nursing and care until the weaning is complete (1 K 11 20). This period in ancient Israel extended to about 3 years, and when it was finished the child was mature enough to be intrusted to strangers (1 S 1 24). And, as the completion of the period marked the end of the most critical stage of the child's life, it was celebrated with a feast (Gen 21 8), a custom still observed in the Orient. The weaned child, no longer fretting for the breast and satisfied with its mother's affection, is used in Ps 131 2 as a figure for Israel's contentment with God's care, despite the smallness of earthly possessions. In Isa 28 9 there is an ironical question, "Is God to teach you knowledge as if you were children? You should have learned His will long ago!"

BURTON SCOTT EASTON

**WEAPONS**, wep'unz. See **ARMOR**.

**WEASEL**, wē'z'l (חֹלֵד, *hōledh*; cf Arab. خُلْد, *khuld*, "mole-rat"): (1) *Hōledh* is found only in Lev 11 29, where it stands first in the list of eight unclean "creeping things that creep upon the earth." AV and RV agree in rendering *hōledh* by "weasel," and LXX has γαλή, *galē*, "weasel" or "martens." According to Gesenius, the Vulg, Tg and Talm support the same rendering. In spite of this array of authorities, it is worth while to consider the claims of the mole-rat, *Spalax typhlus*, Arab. *khuld*. This is a very common rodent, similar in appearance and habits to the mole, which does not exist in Pal. The fact that it burrows may be considered against it, in view of the words, "that creepeth upon the earth." The term "creeping thing" is, however, very applicable to it, and the objection seems like a quibble, esp. in view of the fact that there is no category of subterranean animals. See **MOLE**. (2) The weasel, *Mustela vulgaris*, has a wide range in Asia, Europe, and North America. It is from 8 to 10 in. long, including the short tail. It is brown above and white below. In the northern part of its range, its whole fur, except the tail, is white in winter. It is active and fearless, and preys upon all sorts of small mammals, birds and insects. See **LIZARD**.

ALFRED ELY DAY

**WEATHER**, weth'ēr (זָהָב, *zāhābh* [Job 37 22], יוֹם, *yōm* [Prov 25 20], tr<sup>d</sup> "day"; εὐδία, *eudia*, "clear sky," χεῖμων, *cheimōn*, "tempest"): In the East it is not customary to talk of the weather as in the West. There seems to be no word in the Heb corresponding to "weather." In Job 37 22 AV translates "Fair weather comes out of the north," but RV translates more literally, "Out of the north cometh golden splendor." "As one that taketh off a garment in cold weather [or lit. "on a cold day"], . . . so is he that singeth songs to a heavy heart" (Prov 25 20).

Jesus rebukes the Pharisees for their lack of spiritual foresight when they took such interest in natural foresight. He said, "When it is evening, ye say, It will be fair weather: for the heaven is red. And in the morning, It will be foul weather to-day: for the heaven is red and lowering" (Mt 16 2.3). The general conditions of the weather in the different seasons are less variable in Pal than in colder countries, but the precise weather for a given day is very hard to predict on account of the proximity of the mountains, the desert and the sea.

ALFRED H. JOY

**WEAVING**, wē'ving: Although weaving was one of the most important and best developed of the crafts of Bible times, yet we have but few Bib. references to enlighten us as to the processes used in those early days. A knowledge of the technique of weaving is necessary, however, if we are to understand some of the Bib. incidents. The principle of weaving in all ages is illustrated by the process of darning. The hole to be darned is laid over with parallel threads which correspond to the "warp" (שֵׁט, *shēthī*) of a woven fabric. Then, by means of a darning needle which takes the place of the shuttle in the loom, other threads are interlaced back and forth at right angles to the first set of strands. This second set corresponds to the woof (עֲרֵב, 'ērebh) or weft of woven cloth. The result is a web of threads across the hole. If the warp threads, instead of being attached to the edges of a fabric, are fastened to two beams (see Fig. 1)

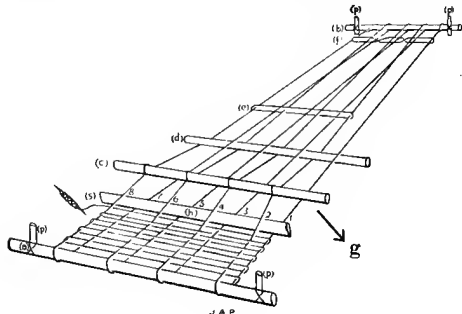

FIG. 1.

which can be stretched either on a frame or on the ground, and the woof is interlaced exactly as in darning, the result will be a web of cloth. The process is then called weaving (אָרַג, 'āragh), and the apparatus a loom. The most up-to-date loom of our modern mills differs from the above only in the devices for accelerating the process. The first of these improvements dates back some 5,000 years to the early Egyptians, who discovered what is technically known as *shedding*, i.e. dividing the warp into two sets of threads, every other thread being lifted so that the woof can run between, as is shown in the diagram of the Arab. loom.

Figs. 1 and 2 show the working of the looms still commonly used among the Bedouins. For the sake of

clearness only eight threads are shown in the warp. In reality the eight strands are made by passing one continuous thread back and forth between the two poles (a) and (b), held apart by the stakes (p) driven into the ground. In Fig. 1 the even strands are shown running through loops of string attached to the rod (c), and thence under the beam (d) to the pole (b). By placing the ends of (c) on stones (see Fig. 3), or by suspending (c) on loops, the

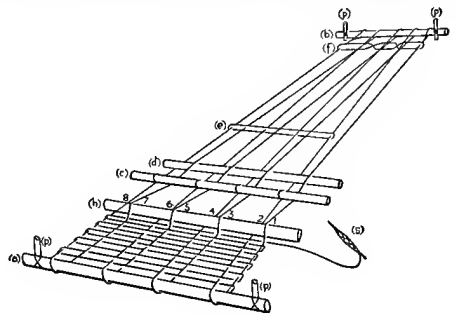

FIG. 2.

even threads are raised above the odd, thus forming a *shed* through which the weft can be passed. The separating of odds and evens is assisted by a flat board (h) of wedge-shaped cross-section, which is turned at right angles to the odds. After the shuttle has been passed across, this same stick is used to beat up the weft. In Fig. 2 the second position of the threads is shown: (c) is removed from the stones or loops, and allowed to lie loosely on the warp; (d) is pulled forward toward the weaver and raised on the stones in the position previously occupied by (c). The flat spreader is passed through the new shed in which the odds are now above and the evens below. The weft is run through and is beaten into place with the thin edge of (h). The shuttle (s) commonly used is a straight tree branch on which the thread is loosely wound "kite-string" fashion.

The loom used by Delilah was no doubt like the one described above (Jgs 16 13.14). It would have been an easy matter for her to run in Samson's locks as strands of the weft while he lay sleeping on the ground near the loom at a position corresponding to (g). The passage might be transposed thus: "And he said unto her, If thou weavest the seven locks of my head into the web. And she passed in his locks and beat them up with the batten [יָאֲהֶדֶחַ, *yāthēdhēh*] [see h, Fig. 1], and said unto him, The Philistines are upon thee, Samson. And he awakened out of his sleep and as he jumped up he pulled away the pins of the loom" (p, Fig. 1).

The counterpart of the Bedouin loom is shown on the ancient tombs at Beni Hasan (see *EB*, 5279, or Wilkinson, I, 317). As Dr. Kennedy points out, the artist of that ancient picture has unwittingly reversed the order of the beams. The shedding beam, of the two, should be nearer the weaver. At what period the crude shedding device described above was replaced by a double set of loops worked by pedals is unknown. Some writers believe that the Jews were acquainted with it. The "flying shuttle" of the modern loom is probably a comparatively recent invention.

The products of the Bedouin looms are coarse in texture. Such passages as Ex 35 35; Isa 19 9, and examples of ancient weaving, lead us to believe that in Bible times contemporaneous with the primitive loom were more highly developed machines, just as in the cities of Egypt and Pal today, alongside of the crude Bedouin loom, are found the more intricate hand looms on which are produced the most delicate fabrics possible to the weaver's art. Examples of cloth comparing favorably with our best grades of muslin have been found among the Egypt mummy wrappings.

Two other forms of looms have been used for weaving, in both of which the warp is upright. In one type the strands of the warp, singly or in bundles, are suspended from a beam and held taut by numerous small weights

made of stones or pottery. Dr. Bliss found at *Tel el-Hesi* collections of weights, sometimes 60 or more together, individual examples of which showed marks where cords had been attached to them. These he assumed were weavers' weights (see *A Mound of Many Cities*). In this form the weaving was necessarily from top to bottom.

The second type of upright loom is still used in some parts of Syria, esp. for weaving coarse goat's hair cloth. In this form the warp is attached to the lower beam and passes vertically upward over another beam and thence to a wall where it is gathered in a rope and tied to a peg, or it is held taut by heavy stone weights. The manipulation is much the same as in the primitive loom, except that the weft is beaten up with an iron comb. The web is wound up on the lower beam as it is woven (cf *Isa 38 12*).

In all these kinds of weaving the Syrian weavers of today are very skilful. If a cylindrical web is referred to in *Jn 19 23*, then Jesus' tunic must have been woven with two sets of warp threads on an upright loom so arranged that the weft could be passed first through one shed and then around to the other side and back through the shed of the second set.

Goliath's spear was compared in thickness to that of the weaver's beam, i.e. 2 in. to 2½ in. in diameter (*1 S 17 7*; *2 S 21 19*; *1 Ch 11 23*; *20 5*) (see *d*, *Fig. 1*).

In *Job 7 6*, if "shuttle" is the right rendering



FIG. 3.—SHOWING "SHED" OF ARAB LOOM.

Patterns are woven into the web (1) by making the warp threads of different colors, (2) by alternating colors in the weft, (3) by a combination of (1) and (2); this produces checked work (*שָׁבִיב*,



FIG. 4.—Showing Upright Loom.

*shibbēc*, *Ex 28 39 RV*); (4) by running special weft threads through only a portion of the warp. This requires much skill and is probably the kind of weaving referred to in *Ex 26 1 ff*; *Ezk 16 13*; *27 16*; (5) when metals are to be woven, they are rolled thin, cut into narrow strips, wound in spirals about threads of cotton or linen (cf *Ex 28 5 ff*; *39 3 ff*).

for *אָרֶג*, 'eregh, the reference is to the rapidity with which the thread of the shuttle is used up, as the second part of the verse indicates.

For a very full discussion of the terms employed see A. R. S. Kennedy in *EB*, IV, 5276-90.

JAMES A. PATCH

**WEB.** See **SPIDER**; **WEAVING**.

**WEDDING.** See **MARRIAGE**.

**WEDGE**, wej, **OF GOLD** (*לָשׁוֹן זָהָב*, *lāshōn zāhābh*, lit. "tongue of gold"): A piece of gold in the form of a wedge found by Achan in the sack of Jericho. It was in one of the forms in which gold was used for money and was probably stamped or marked to indicate its weight, which was 50 shekels, i.e. one *māneh*, according to the Heb standard, or nearly two pounds troy. Its value would be £102 10s., or \$510. See **MONEY**; **POUND**. A wedge, or rather, oblong rectangular strip of gold, of similar weight has been found in the excavations of Gezer (Macalister, *Bible Side-Lights*, 121). Along with metal rings they were doubtless used as an early form of currency. In *Isa 13 12 AV*, *kethem*, "pure gold" (so *RV*), is tr<sup>d</sup> as "golden wedge" on insufficient grounds.

H. PORTER

**WEEDS**, wēdz (*סִבָּה*, *šūph*, "a weed" [*Jon 2 5*]). See **FLAG**; **COCKLE**; **RED SEA**.

**WEEK**, wēk (*שִׁבְעָה*, *shebhū<sup>a</sup>*, from *שִׁבְעָה*, *shebha<sup>a</sup>*, "seven"; *σάββατον-τα*, *sābbaton-ta*, "from sabbath

to sabbath"): The seven-day division of time common to the Hebrews and Babylonians (Gen 29 27, 28; Lk 18 12). See ASTRONOMY; TIME. "Week" is used in the apocalyptic writings of Daniel for an unknown, prophetic period (Dnl 9 24-27). For the names of the days see ASTROLOGY, 12.

**WEEKS, FEAST OF.** See PENTECOST.

**WEEKS, SEVENTY.** See SEVENTY WEEKS.

**WEeping, wēp'ing.** See BURIAL, IV, 4, 5, 6.

**WEIGHT, wāt** (Measure of quantity) (מִשְׁקָל, *mishkāl*, מִשְׁקָל, *mishkōl* [Ezk 4 10], from שָׁקַל, *shākal*, "to weigh," מִשְׁכָּן, *'ebhen*, "a stone," used for weighing in the balance): Weights were commonly

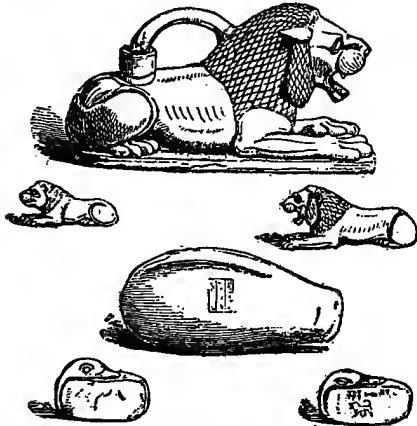

Bronze and Stone Weights Used in Nineveh.

of stone or bronze (or of lead, Zec 5 7,8). They were of various forms, such as the lion-shaped weights of Babylonia and Assyria, or in the form of birds and other animals. The Heb and Phoen weights, when made of stone, were barrel- or spindle-shaped, but in bronze they were often cubical or octagonal or with numerous faces (see illustration under WEIGHTS AND MEASURES). Hemispherical or dome-shaped stone weights have been found in Pal (PEFS, 1902, p. 344; 1903, p. 117; 1904, p. 209).

**Figurative:** The phrase "without weight" (2 K 25 16) signifies a quantity too great to be estimated. "Weight of glory" (2 Cor 4 17, βάρως, *báros*) has a similar meaning, but with a spiritual reference. "Weighty," "weightier" (Mt 23 23; 2 Cor 10 10, βαρύς, *barús*, βαρύτερος, *barύτερος*), signify what is important. The Gr ὄγκος, *óγκος* (He 12 1), is used in the sense of burden, hindrance, as is also the Heb *nētel* (Prov 27 3). H. PORTER

**WEIGHTS, wāts, AND MEASURES:** The system of weights and measures in use among the Hebrews was derived from Babylonia and Egypt, esp. from the former. The influence of these countries upon Pal has long been recognized, but archaeological investigations in recent years have shown that the civilization of Babylonia impressed itself upon Syria and Pal more profoundly in early times than did that of Egypt. The evidence of this

has been most clearly shown by the discovery of the Am Tab, which reveal the fact that the official correspondence between the Egypt kings and their vassals in these lands was carried on in the language of Babylonia long after its political influence had been supplanted by that of Egypt. It is natural, then, that we should look to Babylonia for the origin of such important elements of civilization as a system of weights and measures.

It was quite natural that men should have found a standard for linear measures in the parts of the human body, and we find the cubit,

1. **Linear Measures** originally the length of the forearm, taken as the standard, and the span, the palm and the digit, or finger-breadth, associated with it in linear measurement. They do not seem to have employed the foot, though it is represented in the two-thirds of the cubit, which was used by the Babylonians in the manufacture of building-brick.

This system, though adequate enough for man in the earliest times, was not so for an advanced stage of civilization, such as the Babylonians reached before the days of Abraham, and we find that they had introduced a far more accurate and scientific system (see CUBIT). They seem to have employed, however, two cubits, of different lengths, one for commercial purposes and one for building. We have no undoubted examples of either, but judging by the dimensions of their square building-bricks, which are regarded as being two-thirds of a cubit on a side, we judge the latter to have been of about 19 or 20 in. Now we learn from investigations in Egypt that a similar cubit was employed there, being of from 20.6 to 20.77 in., and it can hardly be doubted that the Hebrews were familiar with this cubit, but that in more common use was certainly shorter. We have no certain means of determining the length of the ordinary cubit among the Hebrews, but there are two ways by which we may approximate its value. The Siloam Inscription states that the tunnel in which it was found was 1,200 cubits long. The actual length has been found to be about 1,707 ft., which would give a cubit of about 17.1 in. (see PEFS, 1902, 179). Of course the given length may be a round number, but it gives a close approximation.

Again, the Mish states that the height of a man is 4 cubits, which we may thus regard as the average stature of a Jew in former times. By reference to Jewish tombs we find that they were of a length to give a cubit of something over 17 in., supposing the stature to be as above, which approximates very closely to the cubit of the Siloam tunnel. The consensus of opinion at the present day inclines toward a cubit of 17.6 in. for commercial purposes and one of about 20 in. for building. This custom of having two standards is illustrated by the practice in Syria today, where the builder's measure, or *dra'*, is about 2 in. longer than the commercial.

Of multiples of the cubit we have the measuring-reed of 6 long cubits, which consisted of a cubit and a hand-breadth each (Ezk 40 5), or about 10 ft. Another measure was the Sabbath day's journey, which was reckoned at 2,000 cubits, or about 1,000 yds. The measuring-line was used also, but whether it had a fixed length we do not know. See SABBATH DAY'S JOURNEY; MEASURING LINE.

The following is the table of linear measures:

LINEAR MEASURE		
Finger or digit (אֶבֶט, <i>'eṣba</i> )	.....	about ½ in.
Hand-breadth or palm (טֶפֶחַ, <i>tephah</i> )	..... 4 digits	" 3 in.
Span (זֶרֶת, <i>zereth</i> )	..... 3 palms	" 9 in.
Cubit (אַמְמָה, <i>'ammāh</i> )	..... 2 spans	" 17.6 in.
Reed (קָנֶה, <i>kāneh</i> )	..... 6 cubits, 6 palms	" 10 ft.
Sabbath day's journey (σαββάτου ὁδός, <i>sabbātou hodós</i> )	..... 2,000 "	" 3,600 ft.

In the NT we have the fathom (*δρυμά, orguid*), about 6 ft., and the furlong (*στράδιον, stáddion*), 600 Gr ft. or 606½ Eng. ft., which is somewhat less than one-eighth of a mile. The mile (*μίλιον, mílion*) was 5,000 Rom ft., or 4,854 Eng. ft., somewhat less than the Eng. mile.

Regarding the absolute value of the measures of capacity among the Hebrews there is rather more uncertainty than there is concerning those of length and weight, since no examples of the former have come down to us; but their relative value is known.

Sir Charles Warren considers them to have been derived from the measures of length by cubing the cubit and its divisions, as also in the case of weight. We learn from Ezk (45 11) that the *bath* and *ephah* were equivalent, and he (Warren) estimates the capacity of these as that of 8⅔ of the cubit cubed, or about 2,333.3 cubic in., which would correspond to about 9 gallons Eng. measure. Assuming this as the standard, we get the following tables for liquid and dry measure:

		LIQUID MEASURE		
1 log	(לֹג, <i>lōgh</i> , Lev 14 10)			approximately 1 pint
4 logs	1 kab (קַב, <i>kabh</i> , 2 K 6 25)			2 qts.
12 "	3 kabs, 1 hin (הִין, <i>hīn</i> , Ex 30 24)			" "
72 "	18 " 6 hins, 1 bath (בַּת, <i>bath</i> , Ezk 45 10)			9 "
720 "	180 " 60 " 10 baths, 1 homer or kor (הוֹמֵר, <i>hōmer</i> , כֹּר, <i>kōr</i> , Ezk 45 14)			90 "

		DRY MEASURE		
1 log				approximately 1 pint
4 logs	1 kab			2 qts.
7½ "	1 omer (אֹמֶר, <i>'ōmer</i> , Ex 16 16)			3 qts., 1½ pts.
24 "	6 kabs, 3½ omers, 1 seah (סֵאָה, <i>sē'āh</i> , 1 K 18 32)			1½ pecks
72 "	18 " 10 " 3 seahs, 1 ephah (אֶפְהָי, <i>'ēphāh</i> , Ex 16 36)			4½ "
360 "	90 " 50 " 15 " 5 ephahs, 1 lethekh (לֶתֶכֶךְ, <i>lethekh</i> , Hos 3 2)			5 bu., 2½ pecks
720 "	180 " 100 " 30 " 10 " 2 lethechs, 1 homer or kor (Ezk 45 14)			11 bu., 1 peck

*Sē'āh* and *lethekh*, in the above, occur in the Heb text, but only in the margin of the Eng. It will be noticed that the prevailing element in these tables is the duodecimal which corresponds to the sexagesimal of the Bab system, but it will be seen that in the case of weights there was a tendency on the part of the Hebrews to employ the decimal system, making the *māneh* 50 shekels instead of 60, and the talent 3,000 instead of 3,600, of the Bab, so here we see the same tendency in making the 'ōmer the tenth of the 'ēphāh and the 'ēphāh the tenth of the *hōmer* or *kōr*.

Weights were probably based by the ancients upon grains of wheat or barley, but the Egyptians and Babylonians early adopted a more

**3. Weights** scientific method. Sir Charles Warren thinks that they took the cubes of the measures of length and ascertained how many grains of barley corresponded to the quantity of water these cubes would contain. Thus he infers that the Egyptians fixed the weight of a cubic inch of rain water at 220 grains, and the Babylonians at 222½. Taking the cubic palm at 25.928 cubic in., the weight of that quantity of water would be 5,760 ancient grains. The talent he regards as the weight of 2/3 of a cubit cubed, which would be equal to 101.6 cubic palms, but assumes that for convenience it was taken at 100, the weight being 576,000 grains, deriving from this the *māneh* (1/60 of the talent) of 9,600 grains, and a shekel (1/50 of the *māneh*) 192 grains. But we have evidence that the Heb shekel differed from this and that they used different shekels at different periods. The shekel derived from Babylonia had a double standard: the light of 160 grains, or 1/3600 of the talent; and the heavy of just double this, of 320 grains. The former seems to have been used before the captivity and the latter after. The Bab system was sexagesimal, i.e. 60 shekels went to the *māneh* and 60 *mānehs* to

the talent, but the Hebrews reckoned only 50 shekels to the *māneh*, as appears from Ex 38 25,26, where it is stated that the amount of silver collected from 603,550 males was 100 talents and 1,775 shekels, and, as each contributed a half-shekel, the whole amount must have been 301,775. Deducting the 1,775 shekels mentioned besides the 100 talents, we have 300,000 or 3,000 to the talent, and, as there were 60 *mānehs* in the talent, there were 50 shekels to each *māneh*. When the Hebrews adopted this system we do not know, but it was in vogue at a very early date.

The shekel was divided into *gerahs*, 20 to a shekel (Ex 30 13). The *gerah* (גֵּרָה, *gērāh*) is supposed to be some kind of seed, perhaps a bean or some such plant. The shekel of which it formed a part was probably the royal or commercial shekel of 160 grains, derived from Babylon. But the Hebrews certainly had another shekel, called the Phoen from its being the standard of the Phoen traders. This would be natural on account of the close connection of the two peoples ever since the days of David and

Solomon, but we have certain evidence of it from the extant examples of the monetary shekels of the Jews, which are of this standard, or very nearly so, allowing some loss from abrasion. The Phoen shekel was about 224 grains, varying somewhat in different localities, and the Jewish shekels now in existence vary from 212 to 220 grains. They were coined after the captivity (see COINS), but whether this standard was in use before we have no means of knowing.

Examples of ancient weights have been discovered in Pal by archaeological research during recent years, among them one from Samaria, obtained by Dr. Chaplin, bearing the inscription, in Heb, *rebha' neqeph* (רֶבַע נֶעֱפָה). This is interpreted, by the help of the cognate Arab., as meaning "quarter-half," i.e. of a shekel. The actual weight is 39.2 grains, which, allowing a slight loss, would correspond quite closely to a quarter-shekel of the light Bab standard of 160 grains, or the quarter of the half of the double standard. Another specimen discovered at *Tell Zakariyeh* weighs 154 grains, which would seem to belong to the same standard. The weights, of which illustrations are given in the table, are all in the collection of the Syrian Protestant College, at Beirut, and were obtained from Pal and Phoenicia and are of the Phoen standard, which was the common commercial standard of Pal. The largest, of the spindle or barrel type (Fig. 1), weighs 1,350 grains, or 87.46 grams, evidently intended for a 6-shekel weight, and the smaller ones of the same type are fractions of the Phoen shekel. Figs. 2 and 3 are of the same standard, one a shekel and the other a two-shekel weight. They each have 12 faces, and the smaller has a lion stamped on each face save one, reminding us of the lion-weights discovered in Assyria and Babylonia. The spindle weights are of black stone, the others of bronze.

TABLE OF HEBREW WEIGHTS

Gerah (Ex 30 13, גֵּרָה, <i>gērāh</i> )	about	11	grains
Bekā' (half-shekel, Ex 38 26, בֶּקַע, <i>bekā'</i> )	"	122	grains
Shekel (שֶׁקֶל, <i>shekel</i> )	"	224 or 225	grains
Māneh = 50 shekels (pound, 1 K 10 17, מֵנֶה, <i>māneh</i> )	"	11,200	"
Talent = 60 mānehs or 3,000 shekels (Ex 38 25, תַּלְתַּיִת, <i>kikkār</i> )	"	672,000	"



WEIGHTS OF PHOENICIAN STANDARD.

The above is the Phoen standard. In the Bab the shekel would be 160 or 320 grains; the māneh 8,000 or 16,000, and the talent 480,000 or 960,000 grains, according as it was of the light or heavy standard.

H. PORTER

**WELL:** (1) בְּאֵר, *bē'ēr*; cf Arab. بَيْتَر, *bī'ter*, "well"

or "cistern"; usually artificial: "And Isaac's servants digged in the valley, and found there a well of springing [m "living"] water" (Gen 26 19); sometimes covered: "Jacob . . . rolled the stone from the well's mouth" (Gen 29 10). *Bē'ēr* may also be a pit: "The vale of Siddim was full of slime pits" (Gen 14 10); "the pit of destruction" (Ps 55 23). (2) בּוֹר, *bōr*, usually "pit": "Let us slay him, and cast him into one of the pits" (Gen 37 20); may be "well": "drew water out of the well of Beth-lehem" (2 S 23 16).

(3) פְּרִיָּה, *p̄rīyā*, usually "running water," "fount," or "source": "Doth the fountain send forth from the same opening sweet water and bitter?" (Jas 3 11); may be "well"; cf "Jacob's well" (Jn 4 6).

(4) פְּרֵאָה, *p̄rēāh*, usually "pit": "the pit of the abyss" (Rev 9 1); but "well"; cf "Jacob's well" (Jn 4 11.12): "Which of you shall have an ass or an ox fallen into a well" (AV "pit") (Lk 14 5).

(5) קְרֵנֶה, *krēnē*, "wells" (Sir 48 17), Lat *fons*, "spring" (2 Esd 2 32).

(6) עַיִן, *'ayin*; cf Arab. عَيْن, *'ain*, "fountain," "spring": "the fountain [EV] which is in Jezreel" (1 S 29 1); "In Elim were twelve springs [AV "fountains"] of water" (Nu 33 9); "She [Rebekah] went down to the fountain" (AV "well") (Gen 24 16); "the jackal's well" (ERV "the dragon's well," AV "the dragon well") (Neh 2 13). (7) מַיָּאן, *ma'yān*, same root as (6); "the fountain [AV "well"] of the waters of Nephtoa" (Josh 18 15); "Passing through the valley of Weeping [AV "Baca"] they make it a place of springs" (AV "well") (Ps 84 6); "Ye shall

draw water out of the wells of salvation" (Isa 12 3).

(8) מַקְוֵה, *māqōr*, usually figurative: "With thee is the fountain of life" (Ps 36 9); "The mouth of the righteous is a fountain [AV "well"] of life" (Prov 10 11); "make her [Babylon's] fountain [AV "spring"] dry" (Jer 51 36); "a corrupted spring" (Prov 25 26). (9) מַבְבִּיעַ, *mabbū'ā*, √ נָבַע, *nābha'*,

"to flow," "spring," "bubble up"; cf Arab. نَبْع, *nab'*, مَنبَع, *manba'*, يَنْبُوع, *yanbū'*, "fountain":

"or the pitcher is broken at the fountain" (Eccl 12 6); "the thirsty ground springs of water" (Isa 35 7).

(10) מוֹצֵא, *mōṣā'*, "spring," √ יָצָא, *yāṣā'*, "to go out," "the dry land springs of water" (Isa 41 18); "a dry land into watersprings" (Ps 107 35); "the upper spring of the waters of Gihon" (2 Ch 32 30).

(11) נֶבְחֶכְח, *nēbhekḥ*, root uncertain, reading doubtful; only in Job 38 16, "Hast thou entered into the springs of the sea?" (12) תְּהוֹם, *t'hōm*, "deep," "abyss"; cf Gen 1 2; tr<sup>d</sup> "springs," AV "depths" (Dt 8 7). (13) גַּל, *gal*, √ גָּלַל, *gālat*, "to roll"; cf Gilgal (Josh 5 9); "a spring shut up" (Cant 4 12). (14) גֻּלְלָה, *gullāh*, "bowl," "basin," "pool," same root: "Give me also springs of water. And he gave her the upper springs and the nether springs" (Josh 15 19); cf Arab. كَلَّة, *kullat*, pronounced *gullat*, "a marble," "a cannon-ball."

As is clear from references cited above, wells and springs were not sharply distinguished in name, though *bē'ēr*, and *p̄rēar* are used mainly of wells, and *'ayin*, *ma'yān*, *mōṣā'*, *mabbū'ā* and (poetically) *māqōr* are chiefly used of fountains. The Arab. *bī'r*, the equivalent of the Heb *bē'ēr*, usually denotes a cistern for rain-water, though it may be qualified as *bī'r jam'*, "well of gathering," i.e. for rain-water, or as *bī'r nab'*, "well of springing water." A spring

or natural fountain is called in Arab. 'ain or nab' (cf Heb 'ayin and mabbūa'). These Arab. and Heb words for "well" and "spring" figure largely in place-names, modern and ancient: Beer (Nu 21 16); Beer-elim (Isa 15 8), etc.; 'Ain (a) on the north-east boundary of Pal (Nu 34 11), (b) in the S. of Judah, perhaps=En-rimmon (Josh 15 32); Enaim (Gen 38 14); Enam (Josh 15 34), etc. Modern Arab. names with 'ain are very numerous, e.g. 'Ain-ul-fashkhah, 'Ain-ul-hajleh, 'Ain-kārim, etc. See CISTERN; FOUNTAIN; PIT; POOL.

ALFRED ELY DAY

WELL, JACOB'S. See JACOB'S WELL.

WELLSPRING, wel'spring (מְקוֹר, mēqōr): Usually "spring" or "fountain" (figuratively), tr<sup>d</sup> "wellspring" only in two passages: "Understanding is a wellspring of life unto him that hath it" (Prov 16 22); "The wellspring of wisdom is as a flowing brook" (Prov 18 4). See Burroughs, *Pepacton*, p. 35; WELL.

WEN: Only in Lev 22 22, "maimed," or "having a wen [m "sores"], or scurvy," for נֶבֶל, yabbāl, "running," hence "a suppurating sore" (cf RVm). A "wen" is a non-inflamed indolent tumor, and so "wen" is about as far as possible from the meaning of the Heb.

WENCH, wench, wensh (שִׁפְחָה, shiphhāh): The word "wench" is found only in 2 S 17 17 AV, where RV has "maid-servant." The Heb word shiphhāh here used is a common term for maid-servant, female slave. AV used the word "wench" to convey the meaning maid-servant, which was a common use of the word at that time, but it is now practically obsolete.

WEST: (1) Usually יָם, yām, "sea," because the Mediterranean lies to the W. of Pal; not usually in figurative expressions; but cf Hos 11 10. (2)

Often מִצְרַב, ma'ārābh; cf Arab. غَرْب, gharb, and مَغْرِب, maghrīb, "west," مَغْرِبُ الشَّمْسِ, maghrīb-ush-shems, or simply مَغْرِب, maghrīb, "sunset." (3) מְבוֹא הַשֶּׁמֶשׁ, m'bhō' ha-shemesh, "entrance of the sun," מְבוֹא, m'bhō', √ בּוֹא, bō', "to come in." (Just as מִצְרָח, mizrah, is the rising of the sun, or east, so מְבוֹא, m'bhō' [or מִצְרַב, ma'ārābh], is the setting of the sun, or west: "From the rising of the sun [mizrah-shemesh] unto the going down [m'bhō'] thereof" [Ps 50 1; cf 113 3; Mal 1 11].) (4) δυσμῆ, dusmē, from δύω, dúō, "to enter," "sink," "set." The Gr usage is || to the Heb just cited: "Many shall come from the east [anatolē, "rising"] and the west" (dusmē, "setting") (Mt 8 11).

The chief figurative use of the word "west" is in combination with "east" to denote great or infinite distance, as:

"As far as the east is from the west,  
So far hath he removed our transgressions  
from us" (Ps 103 12).

ALFRED ELY DAY

WHALE, hwāl: (1) κῆτος, kētos (Sir 43 25 [RV "sea-monster"]; Three ver 57 [RV "whale"]; Mt 12 40 [RV "whale," m "sea-monster"; AV "whale" throughout]). (2) תַּנִּינִן, tannīn (Gen 1 21; Job 7 12), "sea-monster," AV "whale." (3) תַּנְיִים, tannīm (Ezk 32 2), "monster," ERV "dragon," AV "whale," AVm "dragon."

It will be seen from the above references that the word "whale" does not occur in RV except in Three ver 57 and Mt 12 40. Kētos, the original word in these passages, is, according to Liddell and Scott, used by Aristotle for "whale," Aristotle using also the adj. κητώδης, kētōdēs, "cetacean"; Homer and Herodotus used kētos for any large fish or sea-monster or for a seal. It is used in Euripides of the monster to which Andromeda was exposed. In the Heb, in the Book of Jon, we find dāgh or dāghāh, the ordinary word for "fish": "And Jeh prepared a great fish to swallow up Jonah" (Jon 1 17). Whales are found in the Mediterranean and are sometimes cast up on the shore of Pal, but it is not likely that the ancient Greeks or Hebrews were very familiar with them, and it is by no means certain that a whale is referred to, either in the original Jonah story or in the NT reference to it. If any particular animal is meant, it is more likely a shark. Sharks are much more familiar objects in the Mediterranean than whales, and some of them are of large size. See FISH.

In Gen 1 21, "And God created the great sea-monsters" (AV "whales"), and Job 7 12,

"Am I a sea, or a sea-monster [AV "whale"].  
That thou settest a watch over me?"

the Heb has tannīm, which word occurs 14 t in the OT and in ARV is tr<sup>d</sup> "monster," "sea-monster," or "serpent," and, exceptionally, in Lam 4 3, "jackals." AV renders in several passages "dragon" (cf Ezk 29 3 ERV).

Tannīm in Ezk 29 3 and 32 2 is believed to stand for tannīn. ARV has "monster," ERV "dragon," AV "whale," AVm "dragon," in 32 2, and "dragon" in 29 3. Tannīm occurs in 11 other passages, where it is considered to be the pl. of tannīn, and in RV is tr<sup>d</sup> "jackals," in AV "dragons" (Job 30 29; Ps 44 19; Isa 13 22; 34 13; 35 7; 43 20; Jer 9 11; 10 22; 14 6; 49 33; 51 37). In Mal 1 3 we find the fem. pl. tannōth. See DRAGON; JACKAL.

ALFRED ELY DAY

WHEAT, hwēt ([1] חִטָּה, hittāh, the specific word for wheat [Gen 30 14; Ex 34 22, etc], with πυρός, purós [Jth 3 3; Sir 39 26]; [2] בָּר, bar, or בָּרָה, bār [Jer 23 28; Joel 2 24; Am 5 11; 8 6]; in other passages tr<sup>d</sup> "grain" or "corn"; [3] σῖτος, sítos [Mt 3 12; 13 25.29.30; Lk 3 7; 16 7; 22 31, etc] [for other words tr<sup>d</sup> occasionally "wheat" in AV see CORN; FOOD]): Wheat, usually the bearded variety, is cultivated all over Pal, though less so than barley. The great plain of the Hauran is a vast expanse of wheat fields in the spring; considerable quantities are exported via Beirut, Haifa and Gaza. The "wheat harvest" was in olden times one of the regular divisions of the year (Ex 34 22; Jgs 15 1; 1 S 12 17); it follows the barley harvest (Ex 9 31.32), occurring in April, May or June, according to the altitude.

E. W. G. MASTERMAN

WHEEL, hwēl: (1) אֶרְפָּן, 'ōphan, is the usual word (Ex 14 25, etc). In Prov 20 26; Isa 28 27 the rollers of a threshing wagon are meant (see AGRICULTURE). (2) גַּלְגַּל, galgal, "rolling thing," generally in the sense of "wheel" (Isa 5 28, etc), but RV in Ezk 10 2.6.13 has "whirling wheels," an advantageous change. The "wheel . . . broken at the cistern" in Eccl 12 6 is the windlass for drawing the water, and by the figure the breakdown of the old man's breathing apparatus is probably meant. In Ps 83 13, AV has "wheel," but this tr (that of LXX) is quite impossible; RV "whirling dust" (sucked up by a miniature whirlwind) is perhaps right, but the tr<sup>s</sup> proposed are endless. (3) גִּלְגַּל, gilgal, Isa 28 28, the roller of a threshing wagon. (4) אֶבְרָיִם, 'obhnayim, Jer 18 3.



See POTTER. (5) **פָּעַם**, *pa'am*, Jgs 5 28, lit. "step" (so RVm), and the sound of horses' hoofs is intended. (6) **τροχός**, *trochós*, Sir 33 5; Jas 3 6 (AV "course"). In the former passage, "The heart of a fool is as a cart-wheel," the changeableness of a light disposition is satirized. In Jas the figure is of a wheel in rotation, so that a flame starting at any point is quickly communicated to the whole. Just so an apparently insignificant sin of the tongue produces an incalculably destructive effect.

The phrase "wheel of nature" (**τροχός τῆς γενέσεως**, *trochós tēs genéseōs*) is used here for "the world in progress." It is not a very natural figure and has given rise to much discussion. AV accents *tróchos* ("course") instead of *trochós* ("wheel"), but the language throughout is metaphorical and "course" is not a sufficiently metaphorical word. The tr "birth" for *genéseōs* (so RVm), i.e. "a wheel set in motion by birth," is out of the question, as the argument turns on results wider than any individual's existence. "Wheel of nature" is certainly right. But a comparison of life to a wheel in some sense or other (chiefly that of "Fortune's wheel") is common enough in Gr and Lat writers, and, indeed, the exact combination *trochos geneseōs* is found in at least one (Orphic) writer (full references in the comms. of Mayor and W. Bauer). It would seem, then, that St. James had heard the phrase, and he used it as a striking figure, with entire indifference to any technical significance it might have. This supposition is preferable to that of an awkward tr from the Aramaic. See COURSE.

BURTON SCOTT EASTON

**WHELP**, *hwelp* (**גִּיר**, *gūr*, or **גֹּר**, *gōr*; either absol. [Ezk 19 2.3.5; Nah 2 12]; or constr. with 'aryēh, "lion" [Gen 49 9; Dt 33 22; Jer 51 38; Nah 2 11]; also **בְּנֵי לִיָּא**, *bnē lābhī*, lit. "sons of a lioness," tr<sup>d</sup> "the whelps of the lioness" [Job 4 11]. In Job 28 8, AV has "lion's whelps" for **בְּנֵי שְׁהִיָּו**, *bnē shāhāç*, which RV renders "proud beasts," m "sons of pride." In Lam 4 3, *gūr* is used of the young of *tannīn*, RV "jackals," AV "sea-monsters," AVm "sea-calves"; it may possibly mean "wolves"; **σκύμνος**, *skūmnos*, the technical word for "lion's whelp" [1 Mac 3 4]: These references are all figurative: "Judah is a lion's whelp" (Gen 49 9); "Dan is a lion's whelp" (Dt 33 22); it is said of the Babylonians, "They shall roar together like young lions; they shall growl as lions' whelps" (Jer 51 38); of the Assyrians, "Where is the den of the lions, and the feeding-place of the young lions, where the lion and the lioness walked, the lion's whelp, and none made them afraid? The lion did tear in pieces enough for his whelps, and strangled for his lionesses, and filled his caves with prey, and his dens with ravin" (Nah 2 11.12). In Ezk 19 2-9, the princes of Israel are compared to lions' whelps. See DRAGON; LION.

ALFRED ELY DAY

**WHIRLWIND**, *hwūrl'wind* (**שֻׁפְחָה**, *šūphāh* [Prov 1 27; 10 25; Isa 5 28; 17 13; 66 15; Hos 8 7; Am 1 14; Nah 1 3], **צַעַר**, *ça'ar* [Hab 3 14; Zec 7 14; Hos 13 3; Ps 58 9; Dnl 11 40], **קֶצֶר**, *qēçer* [2 K 2 1; Job 38 1; 40 6; Isa 40 24; 41 16; Zec 9 14]): When two currents from opposite directions meet, a circular motion results called a whirlwind. On the sea this takes up small particles of water from the sea and condenses some of the moisture in the clouds above, forming a great funnel-shaped column. They are quite common off the coast of Syria. Considerable damage might be done to a small ship overtaken by them. In the desert sand is taken up in the same way, causing terrible sand storms which are greatly dreaded by caravans. Most of the references in the Bible do not necessarily imply a circular motion, and the word "tempest" might be used in translation.

Storms usually come from the S.W. "Out of the . . . south cometh the storm" (Job 37 9); yet in Ezekiel's vision he saw a whirlwind coming out of the north (1 4). Elijah "went up by a whirlwind into heaven" (2 K 2 11). The whirlwind

indicates the power and might of Jeh: "Jeh hath his way in the whirlwind and in the storm" (Nah 1 3); He "answered Job out of the whirlwind" (Job 38 1).

Most of the Scriptural uses are figurative; of destruction: "He will take them away with a whirlwind" (Ps 58 9; Prov 1 27; 10 25; Hos 13 3; Dnl 11 40; Am 1 14; Hab 3 14; Zec 7 14); of quickness: "wheels as a whirlwind" (Isa 5 28; 66 15; Jer 4 13); of the anger of God: "A whirlwind of the Lord is gone forth in fury" (Jer 23 19 AV); of punishment to the wicked: "A continuing whirlwind . . . shall fall . . . on the wicked" (Jer 30 23 AV).

ALFRED H. JOY

**WHITE**, *hwīt*. See COLORS.

**WHITE HORSE**. See HORSE, WHITE.

**WHITEWASH**, *hwīt'wash*: ARVm gives "whitewash" for "untempered mortar" in Ezk 13 10 and 22 28. 'Her prophets have daubed for them,' i.e. seconded them, "with whitewash," thus giving "a slight wall" (13 10 m) a specious appearance of strength. See MORTAR; UNTEMPERED.

**WHOLE**, *hōl*, **WHOLESOME**, *hōl'sum*: "Whole," originally "hale" (a word still in poetic use), had at first the meaning now expressed by its derivative "healthy." In this sense "whole" is fairly common (Job 5 18, etc) in EV, although much more common in the NT than in the OT. From this meaning "healthy," the transition to the modern force "complete," "perfect," "entire" (Ex 12 6, etc) was not unnatural, and it is in this later sense alone that the advb. "wholly" (Lev 6 22, etc) is used. "Wholesome," however, is derived from the earlier meaning of "whole." It occurs in Prov 15 4, AV, ERV, "a wholesome tongue" (**רֶפְחָה**, *rāphāh*, "heal," RVm "the healing of the tongue," ARV "a gentle tongue"), and in 1 Tim 6 3, AV "wholesome words" (*ὑγιαίνω*, *hugiainō*, "be healthy," RVm "healthful," RV "sound").

BURTON SCOTT EASTON

**WHORE**, *hōr*, **WHOREDOM**, *hōr'dum*. See CRIMES; HARLOT; PUNISHMENTS.

**WICKEDNESS**, *wik'ed-nes*: The state of being wicked; a mental disregard for justice, righteousness, truth, honor, virtue; evil in thought and life; depravity; sinfulness; criminality. See SIN. Many words are rendered "wickedness." There are many synonyms for wickedness in Eng. and also in the Heb. Pride and vanity lead to it: "All the proud, and all that work wickedness (**רִשְׁעִיהִ**, *rish'āh*) shall be stubble" (Mal 4 1). Akin to this is the word **עָוֶן**, *āwen*, "iniquity," "vanity": "She eateth, and wipeth her mouth, and saith, I have done no wickedness" (Prov 30 20). Then we have the word **הַרְוָה**, *harwāh*, meaning "mischief," "calamity," coming from inward intent upon evil: "Lo, this is the man that made not God his strength, but trusted in the abundance of his riches, and strengthened himself in his wickedness" (Ps 52 7); **זִמְמָה**, *zimmāh*, "wickedness" in thought, carnality or lust harbored: "And if a man take a wife and her mother, it is wickedness" (Lev 20 14); **עָוְלָה**, *āwlāh*, "perverseness," "Neither shall the children of wickedness afflict them any more, as at the first" (2 S 7 10). The word for evil (**רָע**, *ra'*) is many times employed to represent wickedness: "Remember all their wickedness" (Hos 7 2). Wickedness like all forms and thoughts of wrong, kept warm in mind, seems to be a thing of growth; it begins with a thought,

then a deed, then a character, and finally a destiny. Even in this life men increase in wickedness till they have lost all desire for that which is good in the sight of God and good men; the men in the vision of Isaiah seem to be in a condition beyond which the human heart cannot go: "Woe unto them that call evil good, and good evil; that put darkness for light, and light for darkness" (Isa 5 20). Shades of thought are added by such words as רָע, *rô'â*, "evil," "badness": "Give them according to their work, and according to the wickedness of their doings" (Ps 28 4). And רָשָׁע, *resha'*, or רָשָׁעִים, *rish'âh*, also gives the common thought of wrong, wickedness. The prophets were strong in denunciations of all iniquity, perverseness, and in announcing the curse of God which would certainly follow.

Wickedness, malignity, evil in thought and purpose is presented by the word *πονηρία*, *ponēria*: "But Jesus perceived their wickedness, and said, Why make ye trial of me, ye hypocrites?" (Mt 22 18). Jesus points out the origin of all wrong: "For from within, out of the heart of men, evil thoughts proceed . . . wickednesses, deceit, lasciviousness . . . all these evil things proceed from within, and defile the man" (Mk 7 21-23). See *Imitation of Christ*, xiii, 5.

DAVID ROBERTS DUNGAN

**WIDOW**, wid'ō (אַלְמָנָה, *'almānāh*; χήρα, *chēra*): In the OT widows are considered to be under the special care of Jeh (Ps 68 5; 146 9; Prov 15 25). Sympathetic regard for them comes to be viewed as a mark of true religion (Job 31 16; Jas 1 27). Dt is rich in counsel in their behalf (24 17, etc).

The word is first mentioned in the NT in Acts 6 1: "There arose a murmuring of the Grecian Jews against the Hebrews, because their widows were neglected in the daily ministration." Paul charges that they be particularly cared for, esp. those that are "widows indeed," i.e. poor, without support and old (1 Tim 5 2-16). Some try to find proof in this passage of that ecclesiastical order of widows mentioned in post-apostolic writings. See LITERATURE, SUB-APOSTOLIC; WOMAN, IV, 5.

GEO. B. EAGER

**WIFE**, wif. See MARRIAGE; RELATIONSHIPS, FAMILY.

**WIFE, BROTHER'S**. See MARRIAGE; RELATIONSHIPS, FAMILY.

**WILD BEAST**, wild bēst: (1) זֵז, *zēz*, only with שָׂדֵה, *sādhay*, "field," in the expression, זֵז שָׂדֵה, *zēz sādhay*, tr<sup>d</sup> "wild beasts of the field" (Ps 50 11; 80 13); of Tg to Ps 80 13, זֵזָא, *zēzā*, "worm" (*BDB*); Arab. زَبْزَب, *zāz*, "worm." (2) צַיִם, *çayim* (Isa 13 21; 34 14; Jer 50 39). (3) אֵיִם, *'ayim* (Isa 13 21; 34 14; Jer 50 39). (4) חַי, *hay*, "living thing," often tr<sup>d</sup> "wild beast" in EV (1 S 17 46, etc). (5) In Apoc (Ad Est 16 24, etc) and the NT (Mk 1 13), θηρίον, *thērion*. (6) Acts 10 12 AV; 11 6, τετράποδον, *tetrápodon*, RV "four-footed beast."

(1), (2) and (3) are of doubtful etymology, but the context makes it clear in each case that wild beasts of some sort are meant. The Tg *zēzā*, "worm," is possible in Ps 80 13, though not probable in view of the || "boar": "The boar out of the wood doth ravage it, and the wild beasts of the field feed on it," i.e. on the vine (figurative) brought out of Egypt. In Ps 50 11, however, such an interpretation is out of the question. All the references from ver 8 to ver 13 are to large animals, bullocks, goats, cattle and birds. Vulg and LXX

have in 80 13 "wild beast" and in 50 11 "beauty of the field" (tr<sup>d</sup>)!

*Çayim*, doubtfully referred to *çiyāh*, "drought," occurs in prophecies of the desolation of Babylon in Isa 13 21 ("wild beasts of the desert") and Jer 50 39, of Edom in Isa 34 14, of Assyria in Isa 23 13 ("them that dwell in the wilderness"). It is associated in these passages with names of wild beasts and birds, some of them of very doubtful meaning, such as *tannim*, *'ōhīm*, *'ayim*, *s'ērīm*, *b'nōth ya'ānāh*. Wild beasts of some sort are clearly meant, though the kind can only be conjectured. The word occurs in Ps 74 14 ("the people inhabiting the wilderness"), where it is possible to understand "beasts" instead of "people." It occurs also in Ps 72 9 ("they that dwell in the wilderness"), where it seems necessary to understand "men." If the reading stands, it is not easy to reconcile this passage with the others.

*'Ayim* occurs in Isa 13 21 and 34 14 and in Jer 50 39, three of the passages cited for *çayim*. AV referring to 'i, "island," renders "wild beasts of the islands" (Isa 13 22). RV has "wolves,"

m "howling creatures"; cf Arab. عَوَى, *'anwa*, "to howl," and ابْن آوَى, *ibn-'āwa*, or وَاوَى, *wāwi*,

"jackal." See JACKAL.

ALFRED ELY DAY

**WILD-OX** (אֵיִם, *'ēim*): The word "unicorn" occurs in AV in Nu 23 22; 24 8; Dt 33 17; Job 39 9,10; Ps 22 21; 29 6; 92 10; Isa 34 7 (AVm "rhinoceros"). RV has everywhere "wild-ox" (m "ox-antelope," Nu 23 22). LXX has μονόκερος, *monókerōs*, "one-horned," except in Isa 34 7, where we find οἱ ἀῤῥοί, *hoi hadroí*, "the large ones," "the bulky ones." In this passage also LXX has οἱ κριοί, *hoi kriói*, "the rams," instead of EV "bullocks." Vulg has *rhinoceros* in Nu 23 22; 24 8; Dt 33 17; Job 39 9,10; and *unicornis* in Ps 22 21 (21 22); 29 6 (28 6); 92 10 (91 11); Isa 34 7.

As stated in the arts. on ANTELOPE and CATTLE, *'ēim* and *t'ō* (Dt 14 5; Isa 51 20) may both be the Arabian oryx (*Oryx beatrix*), of which the common vernacular name means "wild-ox." It may be presumed that "ox-antelope" of Nu 23 22 RVm is meant to indicate this animal, which is swift and fierce, and has a pair of very long, sharp and nearly straight horns. The writer feels, however, that more consideration should be given to the view of Tristram (*Natural History of the Bible*) that *'ēim* is the *urus* or *aurochs*, the primitive *Bos taurus*, which seems to be depicted in Assyrian monuments and referred to as *rēmu* (*BDB*). The etymology of *'ēim* is uncertain, but the word may be from a root signifying "to rise" or "to be high." At any rate, there is no etymological warrant for the assumption that it was a one-horned creature. The Arab. رَيْم, *raim*, is used of a light-colored gazelle.

The great strength and fierceness implied in most of the references suit the wild-ox better than the oryx. On the other hand, Edom (Isa 34 7) was adjacent to the present home of the oryx, while there is no reason to suppose that the wild-ox came nearer than Northern Assyria. There is possibly a reference to the long horns of the oryx in "But my horn hast thou exalted like the horn of the wild-ox" (Ps 92 10). For *t'ō*, LXX has *δρυξ*, *dryx*, in Dt 14 5 (but *σευτλιον ἡμεφθον*, *seullion hēmetephthon*, "half-boiled beet" [!] in Isa 51 20). Vulg has *oryx* in both passages. While we admit that both *'ēim* and *t'ō* may be the oryx, it is perhaps best to follow RVm, rendering *'ēim* "wild-ox." The rendering of "antelope" (RV) for *t'ō* is defensible, but "oryx" would be better, because the oryx is the

only antelope that could possibly be meant, it and the gazelle (*ḡbhē*), already mentioned in Dt 14 5, being the only antelopes known to occur in Pal and Arabia. In Isa 34 7 it seems to be implied that the *r'ēm* might be used in sacrifice.

**Figurative:** The wild-ox is used as a symbol of the strength of Israel: "He hath as it were the strength of the wild-ox" (Nu 23 22; 24 8). In the blessing of the children of Israel by Moses it is said of Joseph:

"And his horns are the horns of the wild-ox:  
With them he shall push the peoples all of them,  
even the ends of the earth" (Dt 33 17).

The Psalmist (29 5.6) in describing the power of Jeh says:

"Yea, Jeh breaketh in pieces the cedars of Lebanon.  
He maketh them also to skip like a calf;  
Lebanon and Sirion like a young wild-ox."

Again, in praise for Jeh's goodness (92 10): "But my horn hast thou exalted like the horn of the wild-ox."

In Job 39 9-12 the subduing and training of the wild-ox are cited among the things beyond man's power and understanding. See ANTELOPE; CATTLE.

ALFRED ELY DAY

**WILDERNESS**, wil'dēr-nes. See DESERT; JUDAEA, WILDERNESS OF; WANDERINGS OF ISRAEL.

**WILL.** See TESTAMENT.

**WILL, VOLITION**, vō-lish'un (וָלָה, 'ābhāh, וָלָה, *rāḡōn*; θέλω, *thelō*, βούλομαι, *boulomai*, θέλημα, *thelēma*): "Will" as noun and vb., trans and intrans, carries in it the idea of "wish," "purpose," "volition." "Will" is also used as an auxiliary of the future tense of other words, but the independent vb. is frequent, and it is often important to distinguish between it and the mere auxiliary, esp. in the NT.

In the OT the word chiefly rendered "to will" is 'ābhāh, "to breathe after," "to long for." With the exception of Job 39 9; Isa 1 19, it is accompanied by a negation, and is used of both man and God. Several other words are employed, but only sparsely. "Will" as noun is the tr chiefly of *rāḡōn*, "good-will," "wilfulness" (Gen 49 6), with emphasis on the voluntariness of action (Lev 1 3; 19 5; 22 19, 29, etc.); also of *nephesh*, and a few other words. In the NT "will" is chiefly the tr of *thelō* and *boulomai*, the difference between the two being that *thelō* expresses an active choice or purpose, *boulomai*, "passive inclination or willingness, or the inward predisposition from which the active choice proceeds" (cf Mk 15 9.12 with ver 15). "Will," noun, is *thelēma*. With the exception of a few passages, it is used of the will of God (over all, Mt 18 14; in all things to be done, Mt 6 10; 26 42 ||, etc.; ordering all things, Eph 1 11, etc.); human will, however, may oppose itself to the will of God (Lk 23 25; Jn 1 13; Rom 7 18; here the capacity to *will* is distinguished from the power to *do*, etc). *Boulēma* is properly counsel or purpose. While it is possible to oppose the will of God, His counsel or purpose cannot be frustrated (Acts 2 23; 4 28; Rom 9 19; Eph 1 11; He 6 17); it may, however, be resisted for a time (Lk 7 30).

In Apoc. for "will" we have *thelēma* (1 Esd 9 9 [of God]; Ecclus 43 16; 1 Macc 3 60; Ecclus 8 15, "his own will"; *boulē* (Wisd 9 13, RV "counsel"; *boulēma* (2 Macc 15 5, "wicked will," RV "cruel purpose"); "wilful" (Ecclus 30 8) is *proalēs*, RV "headstrong"; "willing" (Wisd 14 19), *boulomai*, RV "wishing"; "willing" (Wisd 6 35); "wilt" (Wisd 12 18), *thelō*, RV "hast the will" (cf 2 Macc 7 16).

RV has many changes, several of them of note as bringing out the distinction between the auxiliary and the independent vb. Thus, Mt 11 27, "will-

eth to"; Jn 7 17, "if any man willeth to do his will"; 1 Tim 6 9, ARV "they that are minded to be rich," ERV "desire," etc.

The words employed and passages cited show clearly that man is always regarded as a responsible being, free to will in harmony with the Divine will or contrary to it. This is further shown by the various words denoting refusal. "Ye will not come to me, that ye may have life" (Jn 5 40). So with respect to temptation. We may even choose and act deliberately in opposition to the will of God. Yet God's counsel, His will in its completeness, ever prevails, and man, in resisting it, deprives himself of the good it seeks to confer upon him.

In modern psychology the tendency is to make *will* primary and distinctive of personality.

W. L. WALKER

**WILL-WORSHIP:** In Col 2 23, "a show of wisdom in will-worship," for *ἐθειλοθησκία*, *ethelothrēskia*, a word found nowhere else but formed exactly like "will-worship": worship originating in the human will as opposed to the Divine, arbitrary religious acts, worthless despite their difficulty of performance.

**WILLOW TREE**, wil'ō-trē (וְלָחַץ, *ḡaphṣāphāh*):

Comparison with the Arab. صَفْصَف, *ṣafṣāf*, "the willow," makes it very probable that the tr of Ezk 17 5 is correct.

**WILLOWS**, wil'ōz (וְלָחַץ, 'ārābhīm; *lrea*, *itēa* [Lev 23 40; Job 40 22; Ps 137 2; Isa 15 7; 44 4]): In all references this tree is mentioned as beside running water. They may all refer to the willow, two varieties of which, *Salix fragilis* and *S. alba*, occur commonly in Pal, or to the closely allied *Populus euphratus* (also N.O. *Salicaceae*), which is even more plentiful, esp. on the Jordan and its tributaries. The Brook of the Willows (Isa 15 7) must have been some stream running from Moab to the Jordan or Dead Sea. Popular fancy has associated the willows of Ps 137 2 with the so-called "weeping willow" (*Salix babylonica*), but though this tree is found today in Pal, it is an introduction from Japan and cannot have existed "by the waters of Babylon" at the time of the captivity.

E. W. G. MASTERMAN

**WILLOWS, THE BROOK OF THE:** Evidently mentioned as the boundary of Moab (Isa 15 7) and generally identified with the brook Zered. See BROOK; ZERED.

**WIMPLE**, wim'p'l: RV substitutes "shawls" for AV "wimples" in Isa 3 22. The precise article of dress intended is unknown. See DRESS.

**WIND**, wind (וְרָח, *rāḡh*; ἄνεμος, *ánemos*): Unequal distribution of heat in the atmosphere causes currents of air or wind. The heated air rises and the air from around rushes in. The direction from which a current comes determines its name, as west wind coming from the W. but blowing toward the E. When two currents of air of different directions meet, a spiral motion sometimes results. See WHIRL-WIND.

In Pal the west wind is the most common. It comes from the sea and carries the moisture which condenses to form clouds, as it is turned

2. West upward by the mountains, to the cooler layers of the atmosphere. If the temperature reached is cool enough the cloud condenses and rain falls. Elijah looked toward the W. for the "small cloud," and soon "the heavens grew black with clouds and wind" (1 K 18 44 f). "When ye see a cloud rising in the west,

straightway ye say, There cometh a shower; and so it cometh to pass" (Lk 12 54).

The south wind is frequent in Pal. If it is slightly S.W., it may bring rain, but if it is due S. or S.E., there is no rain. It is a warm wind

**3. South Wind** bringing good weather. "When ye see a south wind blowing, ye say, There will be a scorching heat; and it cometh to pass" (Lk 12 55). In the cooler months it is a gentle, balmy wind, so that the "earth is still by reason of the south wind" (Job 37 17; cf Cant 4 16).

The north wind is usually a strong, continuous wind blowing down from the northern hills, and while it is cool it always "drives away rain," as correctly stated in Prov 25 4. **4. North Wind** 23 AV; yet it is a disagreeable wind, and often causes headache and fever.

The east wind or sirocco (from Arab. *shark*="east") is the "scorching wind" (Jas 1 11) from the desert. It is a hot, gusty wind laden with sand and dust and occurs most frequently in May and October.

**5. East Wind** The temperature in a given place often rises 15 or 20 degrees within a few hours, bringing the thermometer to the highest readings of the year. It is customary for the people to close up the houses tightly to keep out the dust and heat. The heat and dryness wither all vegetation (Gen 41 6). Happily the wind seldom lasts for more than three days at a time. It is the destructive "wind of the wilderness" (Job 1 19; Jer 4 11; 13 24): "Jeh caused the sea to go back by a strong east wind all the night" (Ex 14 21) for the children of Israel to pass; the "rough blast in the day of the east wind" (Isa 27 8). The strength of the wind makes it dangerous for ships at sea: "With the east wind thou breakest the ships of Tarshish" (Ps 48 7). **Euraquilo** or **Euroclydon** (Acts 27 14 AV), which caused Paul's shipwreck, was an E.N.E. wind, which was esp. dangerous in that region.

The wind is directly of great use to the farmer in Pal in winnowing the grain after it is threshed by treading out (Ps 1 4; 35 5; Isa 17 13). It was used as a sign of the weather (Eccl 11 4). It was a necessity for traveling on the sea in ancient times (Acts 28 13; Jas 3 4), but too strong a wind caused shipwreck (Jon 1 4; Mt 8 24; Lk 8 23).

The Scriptural references to wind show many illustrative and figurative uses: (1) Power of God (1 K 19 11; Job 27 21; 38 24; Ps 107 25; 135 7; 147 18; 148 8; Prov 30 4; References Jer 10 13; Hos 4 19; Lk 8 25): "He caused the east wind to blow in the heavens; and by his power he guided the south wind" (Ps 78 26).

(2) Scattering and destruction: "A stormy wind shall rend it" (Ezk 13 11; cf 5 2; 12 14; 17 21; Hos 4 19; 8 7; Jer 49 36; Mt 7 25). (3) Uncertainty: "tossed to and fro and carried about with every wind of doctrine" (Eph 4 14; cf Prov 27 16; Eccl 1 6; Jn 3 8; Jas 1 6). (4) Various directions: "toward the four winds of heaven" (Dnl 11 4; cf 8 8; Zec 2 6; Mt 24 31; Mk 13 27). (5) Brevity: "a wind that passeth away" (Ps 78 39; cf 1 4; 35 5; 103 16). (6) Nothingness: "Molten images are wind" (Isa 41 29; cf Jer 5 13).

ALFRED H. JOY

**WINDOW**, win'dō. See **HOUSE**, II, 1, (9).

**WINDOWS OF HEAVEN**. See **ASTRONOMY**, III, 4.

**WINE**, wīn, **WINE PRESS**, win'pres:

**I. Terms.**—(1) יַיִן, *yayin*, apparently from a non-Sem root allied to Gr (*w*)*oinos*, Lat *vinum*, etc.

This is the usual word for "wine" and is found 141 t in MT. (2) חֵמֶר, *hemer*, perhaps "foaming" (Dt 32 14 and MT Isa 27 2 [but

**1. Wine** see ERVm); Aram. חֵמֶר, *hāmar* (Ezr 6 9; 7 22; Dnl 5 1.2.4.23). (3)

חֵיִרֹשׁ, *tīrōsh*. Properly this is the fresh grape juice (called also מִשְׁרֵה, *mishreh*, Nu 6 3), even when still in the grape (Isa 65 8). But unfermented grape juice is a very difficult thing to keep without the aid of modern antiseptic precautions, and its preservation in the warm and not over-cleanly conditions of ancient Pal was impossible. Consequently, *tīrōsh* came to mean wine that was not fully aged (although with full intoxicating properties [Jgs 9 13; Hos 4 11; cf Acts 2 13]) or wine when considered specifically as the product of grapes (Dt 12 17; 18 4, etc). LXX always (except Isa 65 8; Hos 4 11) translates by *oinos* and the Tgs by *hāmar*. AV has "wine" 26 t, "new wine" 11 t, "sweet wine" in Mic 6 15; RV "vintage" in Nu 18 12; Mic 6 15 (with the same change in Neh 10 37.39 RVm; Isa 62 8 ERVm). Otherwise ERV has left AV unchanged, while ARV uses "new wine" throughout. (4) Two apparently poetic words are עֲסִיס, 'asīs (RV "sweet wine," Isa 49 26; Am 9 13; Joel 1 5; 3 18, "juice"; Cant 8 2), and סֹבֵה, *sōbhe* ("wine," Isa 1 22; "drink," Hos 4 18 [m "carouse"; Nah 1 10]. (5) For spiced wine three words occur: מִצְּהָ, *mezekh*, Ps 75 8 (EV "mixture"); מִמְּסָח, *mim-sākh*, Prov 23 30 ("mixed wine"); Isa 65 11 (RV "mingled wine"); מִזְּעֵה, *mezegh*, Cant 7 2 (RV "mingled wine"); cf also יַיִן הַרְקָה, *yayin hā-rekah*, Cant 8 2 ("spiced wine"). (6) מִמְּתַקִּים, *mam-thakīm*, lit. "sweet," Neh 8 10.

(7) שֶׁכָּחַר, *shēkhār* (22 t), tr "strong drink" in EV. *Shēkhār* appears to mean "intoxicating drink" of any sort and in Nu 28 7 is certainly simply "wine" (cf also its use in parallelism to "wine" in Isa 5 11.22, etc). In certain passages (Lev 10 9; Nu 6 3; 1 S 1 15, etc), however, it is distinguished from "wine," and the meaning is not quite certain. But it would seem to mean "drink not made from grapes." Of such only pomegranate wine is named in the Bible (Cant 8 2), but a variety of such preparations (made from apples, quinces, dates, barley, etc) were known to the ancients and must have been used in Pal also. The tr "strong drink" is unfortunate, for it suggests "distilled liquor," "brandy," which is hardly in point. See **DRINK**, **STRONG**.

(8) In the Apoc and NT "wine" represents *oinos*, with certain compounds, except in Acts 2 13, where the Gr is γλυκός, *glūkōs*, "sweet," EV "new wine."

See also **BLOOD**; **DRINK**; **FLAGON**; **FRUIT**; **HONEY**.

(1) Properly speaking, the actual wine press was called גַּת, *gath* (Jgs 6 11, etc), and the receiving vat ("fat") יַקֵּב, *yekēbh* (Nu 18 27,

**2. Wine Press** etc), but the names were interchangeable to some degree (Isa 16 10; Job 24 11; cf Isa 5 2, RV text and m) and either could be used for the whole apparatus (see **GATH** and cf Jgs 7 25; Zec 14 10). In Isa 63 3 the Heb has פְּרִירָה, *pūrah*, "wincetrough," a word found also in Hag 2 16 where it seems to be a gloss (so, apparently, ARV).

(2) In the Apoc (Sir 33 16) and in the NT (Mt 21 33; Rev 14 19.20 [bvs]; 19 15) "winepress" is λητός, *lēnōs*; in Mk 12 1 *πολῆμιον*, *hupolēmion*, by which only the receiving vat seems to be meant (RV "a pit for a winepress").

**II. Wine-Making.**—For the care of the vine, its distribution, different varieties, etc, see **VINE**. The ripening of the grapes took place as early as June in the Jordan valley, but on the coast not until August, while in the hills it was delayed until September. In whatever month, however, the

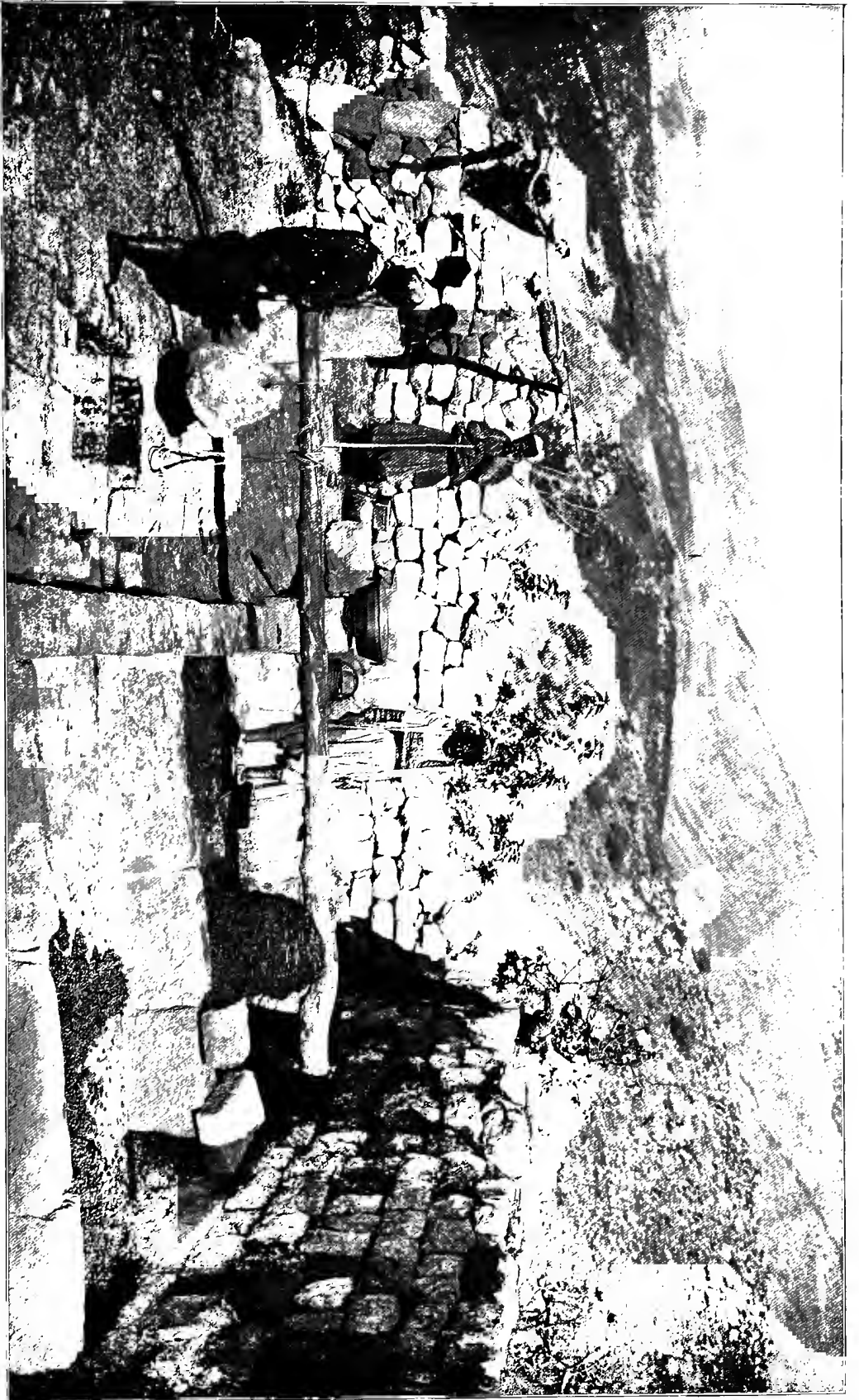

MODERN SYRIAN WINE PRESS



coming of the vintage was the signal for the villagers to leave their homes in a body and to encamp in booths erected in the vineyards, so that the work might be carried on without interruption (see **TABERNACLES, FEAST OF**).

### 1. The Vintage

It was the great holiday season of the year and the joy of the vintage was proverbial (Isa 16 10; Jer 25 30; 48 33; cf Jgs 9 27), and fragments of vintage songs seem to be preserved in Isa 27 2; 65 8. The grapes were gathered usually by cutting off the clusters (see **SICKLE**), and were carried to the press in baskets.

Many of the ancient wine presses remain to the present day. Ordinarily they consisted of two

### 2. Wine Presses

rectangular or circular excavations, hewn (Isa 5 2) in the solid rock to a depth of 2 or 3 feet. Where possible one was always higher than the other and they were connected by a pipe or channel. Their size, of course, varied greatly, but the upper

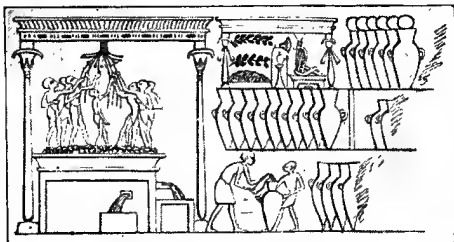

Large Foot Press (Egyptian).

vat was always wider and shallower than the lower and was the press proper, into which the grapes were thrown, to be crushed by the feet of the treaders (Isa 63 1-3, etc.). The juice flowed down through the pipe into the lower vat, from which it was removed into jars (Hag 2 16) or where it was allowed to remain during the first fermentation.

Many modifications of this form of the press are found. Where there was no rock close to the surface, the vats were dug in the earth and lined with stonework or cement, covered with pitch. Or the pressvat might be built up out of any material (wood was much used in Egypt), and from it the juice could be conducted into a sunken receptacle or into jars. Not infrequently a third (rarely a fourth) vat might be added between the other two, in which a partial settling and straining could take place. Wooden beams are often used either to finish the pressing or to perform the whole operation, and holes into which the ends of these beams fitted can still be seen. A square of wood attached to the beam bore down on the pile of grapes, while the free end of the beam was heavily weighted. In the simpler presses the final result was obtained by piling stones on the mass that remained after the treaders had finished their work.

It is a general principle of wine-making (cf **On**) that "the less the pressure the better the product"; therefore the liquid that flowed at the

### 3. Grading

beginning of the process, esp. that produced by the mere weight of the grapes themselves when piled in heaps, was carefully kept separate from that which was obtained only under heavy pressure. A still lower grade was made by adding water to the final refuse and allowing the mixture to ferment. Possibly this last concoction is sometimes meant by the word "vinegar" (*homec*).

In the climate of Pal fermentation begins almost immediately, frequently on the same day for juice pressed out in the morning, but never later than the next day. At first a slight foam appears on

the surface of the liquid, and from that moment, according to Jewish tradition, it is liable to the wine-tithe (*Ma'asēroth* 1 7). The ac-

### 4. Fermentation

tion rapidly becomes more violent, and while it is in progress the liquid must be kept in jars or in a vat, for it would burst even the newest and strongest of wine-skins (Job 32 19). Within about a week this violent fermentation subsides, and the wine is transferred to other jars or strong wine-skins (Mk 2 22 and ¶'s), in which it undergoes the secondary fermentation. At the bottom of the receptacles collect the heavier matter or "lees" (לֵשׁ, *sh'mārim*, Ps 75 8 ["dregs"]; Jer 48 11; Zeph 1 12; in Isa 25 6 the word is used for the wine as well), from which the "wines on the lees" gather strength and flavor.

At the end of 40 days it was regarded as properly "wine" and could be offered as a drink offering (*Eḏhuyyōth* 6 1). The practice after this point seems to have varied, no doubt depending on the sort of wine that was being made. Certain kinds were left undisturbed to age "on their lees" and were thought to be all the better for so doing, but before they were used it was necessary to strain them very carefully. So Isa 25 6, 'A feast of wine aged on the lees, thoroughly strained.' But usually leaving the wine in the fermentation vessels interfered with its improvement or caused it to degenerate. So at the end of 40 days it was drawn off into other jars (for storage, 1 Ch 27 27, etc.) or wine-skins (for transportation, Josh 9 4, etc.). So Jer 48 11: 'Moab has been undisturbed from his youth, and he has rested on his lees and has not been emptied from vessel to vessel. . . . Therefore his flavor remains unchanged [or "becomes insipid"] and his scent is unimproved [or "lacks freshness"];' cf Zeph 1 12.

Jars were tightly sealed with caps covered with pitch. The very close sealing needed to preserve sparkling wines, however, was un-

### 5. Storage

known to the Hebrews, and in consequence (and for other reasons) such wines were not used. Hence in Ps 75 8, "The wine foameth," the allusion must be to very new wine whose fermentation had not yet subsided, if, indeed, the tr is not wrong (RVm "The wine is red"). The superiority of old wine to new was acknowledged by the Hebrews, in common with the rest of the world (Sir 9 10; Lk 5 39), but in the wines of Pal acetous fermentation, changing the wine into vinegar, was likely to occur at any time. Three years was about the longest time for which such wines could be kept, and "old wine" meant only wines that had been stored for a year or more (*Bab. Bath.* 6 3). See also **CRAFTS**, II, 19.

**III. Use of Wine.**—In OT times wine was drunk undiluted, and wine mixed with water was thought

### 1. Mixed Wine

to be ruined (Isa 1 22). The "mixed" or "mingled wines" (see I, 1, (5), above) were prepared with aromatic herbs of various sorts and some of these compounds, used throughout the ancient world, were highly intoxicating (Isa 5 22). Wine mixed with myrrh was stupefying and an anaesthetic (Mk 15 23). At a later period, however, the Gr use of diluted wines had attained such sway that the writer of 2 Macc speaks (15 39) of undiluted wine as "distasteful" (*polēmion*). This dilution is so normal in the following centuries that the Mish can take it for granted and, indeed, R. Eliezer even forbade saying the table-blessing over undiluted wine (*Brākhoth* 7 5). The proportion of water was large, only one-third or one-fourth of the total mixture being wine (*Niddah* 2 7; *P'sahim* 108b).

**NOTE.**—The wine of the Last Supper, accordingly, may be described in modern terms as a sweet, red, fermented wine, rather highly diluted. As it was no doubt

the ordinary wine of commerce, there is no reason to suppose that it was particularly "pure."

Throughout the OT, wine is regarded as a necessity of life and in no way as a mere luxury. It

was a necessary part of even the simplest meal (Gen 14 18; Jgs 19 19; 2 Wine-Drinking 1 S 16 20; Isa 55 1, etc), was an indispensable provision for a fortress (2 Ch 11 11), and was drunk by all classes and all ages, even by the very young (Lam 2 12; Zec 9 17). "Wine" is bracketed with "grain" as a basic staple (Gen 27 28, etc), and the failure of the wine-crop or its destruction by foreigners was a terrible calamity (Dt 28 30-39; Isa 62 8; 65 21; Mic 6 15; Zeph 1 13, etc). On the other hand, abundance of wine was a special token of God's blessing (Gen 27 28; Dt 7 13; Am 9 14, etc), and extraordinary abundance would be a token of the Messianic age (Am 9 13; Joel 3 18; Zec 9 17). A moderate "gladdening of the heart" through wine was not looked upon as at all reprehensible (2 S 13 28; Est 1 10; Ps 104 15; Eccl 9 7; 10 19; Zec 9 15; 10 7), and while Jgs 9 13 represented a mere verbal remnant of a long-obsolete concept, yet the idea contained in the verse was not thought shocking. "Drink offerings," indeed, were of course a part of the prescribed ritual (Lev 23 13, etc; see SACRIFICE), and a store of wine was kept in the temple (tabernacle) to insure their performance (1 Ch 9 29). Even in later and much more moderate times, Sir writes the laudation of wine in 31 27, and the writer of 2 Mace (see above) objects as strongly to pure water as he does to pure wine. Christ adapted Himself to Jewish customs (Mt 11 19 || Lk 7 34; Lk 22 18), and exegetes usually suppose that the celebrated verse 1 Tim 5 23 is meant as a safeguard against ascetic (gnostic?) dualism, as well as to give medical advice.

On the temporal conditioning of the Bib. customs, the uncompromising opposition of the Bible to excess, and the non-applicability of the ancient attitude to the totally different modern conditions, see DRUNKENNESS.

The figurative uses of wine are very numerous, but are for the most part fairly obvious. Those offering difficulty have been discussed in the course of the article. For wine in its commercial aspect see TRADE. BURTON SCOTT EASTON

**WINEBIBBER**, win'bib-ēr: In Prov 23 20, **יַיִן וְכֶסֶם**, *šōbhē' yayin*; in Mt 11 19=Lk 7 34, *οἰνοπότης, oinopótēs*, of habitual wine-drinkers. The accusation was falsely brought against Jesus of being "a gluttonous man and a winebibber," because, unlike John, He ate and drank with others.

**WINEFAT**, win'fat, **WINE PRESS**, win'pres, **WINEVAT**, win'vat. See CRAFTS, II, 19; VINE; WINE.

**WINE-SKINS** (יֵרֵךְ, *hēmēth* [Gen 21 14 m], **נֶבֶל**, *n'ōdh* [Jgs 4 19, "bottle"], **נֶבֶל**, *nēbel*, **בֶּל**, *nēbel* [1 S 10 3 m], **אֲסוֹס**, *'ōbh* [Job 32 19]; **ἀσκός**, *askós* [Mt 9 17; Mk 2 22; Lk 5 37; cf **ἀσκοπυτήνη**, *askopytēnē*, Jth 10 5, RV "leathern bottle"]): These words are all used to designate skins for the containing of liquids, *nēbel*, however, being the most common in the case of wine. The Israelite, like the modern Arab and Syrian, used mainly the skin of the goat and the sheep, but the skins of the ox and the camel have also been put to this purpose. The skin is removed from the animal by drawing it over the body from the neck downward, half the skin on each of the limbs being also retained. It is then tanned, the hair cut close, turned inside out, and has all the openings save one closed with cords, when it is ready for use. The reference to "a wine-

skin in the smoke" in Ps 119 83 is generally explained on the supposition of its being hung there for mellowing purposes, but this can scarcely be accepted, for wine is never left for any length of time in the skin on account of its imparting a disagreeable flavor to the contents. The explanation of the NT passages is that the new wine, still liable to continue fermenting to a small extent at least, was put into new, still expandible skins, a condition that had ceased in the older ones. See WINE.

W. M. CHRISTIE

**WINEVAT**. See WINEFAT, WINEVAT.

**WINGS**, wingz (כַּנְפֵי, *kānāph*; πτέρυξ, *ptérux*): Bib. references to the wings of birds are common, esp. in Pss, many of them exquisitely poetical. Often the wings of an eagle are mentioned because they are from 7 to 9 ft. in sweep, of untiring flight, and have strength to carry heavy burdens: so they became the symbol of strength and endurance. Ancient monuments and obelisks are covered with the heads of bulls, lions, different animals, and men even, to which the wings of an eagle were added to symbolize strength. Sometimes the wings of a stork are used to portray strong flight, as in the vision of Zechariah: "Then lifted I up mine eyes, and saw, and, behold, there came forth two women, and the wind was in their wings; now they had wings like the wings of a stork; and they lifted up the ephah between earth and heaven" (5 9). The wings of a dove symbolized love. Wings in the abstract typified shelter, strength or speed, as a rule, while in some instances their use was ingenious and extremely poetical, as when Job records that the Almighty used wings to indicate migration: "And stretcheth her wings toward the south" (39 26). In Ps 17 8 there is a wonderful poetical imagery in the plea, "Hide me under the shadow of thy wings." In Ps 18 10 there is a reference to "the wings of the wind." And in 55 6 the Psalmist cries, "Oh that I had wings like a dove!" The brightness and peace of prosperous times are beautifully described in Ps 68 13, "the wings of a dove covered with silver, and her pinions with pale green gold." The first rays of dawn are compared to "the wings of the morning" (139 9). Solomon was thinking of the swiftness of wings when he said, "For riches certainly make themselves wings, like an eagle that flieth toward heaven" (Prov 23 5). So also was Isaiah in 40 31, "They that wait for Jeh shall renew their strength; they shall mount up with wings as eagles; they shall run, and not be weary; they shall walk, and not faint." In Mal 4 2 AV, there is a beautiful reference, "But unto you that fear my name shall the Sun of righteousness arise with healing in his wings." RV changes "his" to "its." Wings as an emblem of love were used by Jesus in the cry, "O Jerusalem . . . how often would I have gathered thy children . . . as a hen gathereth her chickens under her wings" (Mt 23 37). GENE STRATTON-PORTER

**WINK**, wink (רָזַם, *rāzam*, lit. "to roll the eyes"): The act or habit of winking was evidently considered to be evil both in its motives and in its results. The idea of its facetiousness, prevalent in our day, is nowhere apparent in the Scriptures. It is mentioned frequently, but is always associated with sin, in the OT esp. in the sense of conceit, pride, and rebellion against God: "Why doth thine heart carry thee away? and what do thy eyes wink at, that thou turnest thy spirit against God" (Job 15 12.13 AV). So also Ps 35 19: "Neither let them wink with the eye that hate me without a cause." "A naughty person, a wicked man, walketh with a froward mouth. He winketh with his eyes," etc (Prov 6 12.13 AV). "He that winketh with the



eye causeth sorrow" (10 10). See Watkinson, *Education of the Heart*, "Ethics of Gesture," 194 ff.

In the NT the word is used to express the long-suffering patience and forgiveness of God toward erring Israel: "And the times of this ignorance God winked at" (Acts 17 30 AV, *ὑπερείδων, hyperéidon*, "overlooked," and so tr'd in RV; cf Wisd 11 23; Ecclus 30 11). The use of "winked" in this connection would in our day, of course, be considered in bad taste, if not actually irreverent, but it is an excellent example of the colloquialism of AV.

ARTHUR WALWYN EVANS

**WINNOWING**, win'o-ing. See AGRICULTURE; FAN; THRESHING.

**WINTER**, win'tēr (חֹרֶף, *hōreph*, from חָרַף, *hārāph*, "to inundate," "overflow"): The rainy season, also the autumn harvest season (Gen 8 22; Ps 74 17; Zec 14 8). It is also the time of cold (Jer 36 22; Am 3 15). The vb. "to winter" occurs in Isa 18 6. *Šṭhāw* (שָׁטָו) has the same meaning as *hōreph* (Cant 2 11). *χειμών, cheimōn*, corresponds to *hōreph* as the rainy season, and the vb. *παραχειμάτω, paracheimázō*, signifies "to pass the winter" (Acts 27 12), the noun from which is *παραχειμασία paracheimasia* (ib). See SEASONS.

**WINTER-HOUSE** (בֵּית־חֹרֶף, *bēth ha-hōreph* [Jer 36 22; Am 3 15]): See under SUMMER-HOUSE. The "winter-house" in Jer is that of King Jehoiakim; mention is made of the fire burning in the brazier.

**WISDOM**, wiz'dum:

- |                       |                        |
|-----------------------|------------------------|
| 1. Linguistic         | 6. Remainder of the NT |
| 2. History            | (1) James              |
| 3. Religious Basis    | (2) Paul               |
| 4. Ideals             | 7. Hypostasis          |
| 5. Teaching of Christ | LITERATURE             |

In RV the noun "wisdom" and its corresponding adj. and vb. ("be wise," "act wisely," etc) represent

a variety of Heb words: בֵּין, *bīn*

**1. Lin-  
guistic** (בִּינָה, *bīnāh*, and in ERV *הַבִּינָה, ḥbhūnāh*); שָׁכַל, *sākhāl* (שֶׁכֶל, *sēkheh*, *ṣēkhel*); לֵב, *lēbh* (and in ERV *לִבָּב, lābhābh*); חֵכְמָה, *ḥōkhmāh* (and in ERV *חֵכְמָה, ḥōkhmāh*); חֵכְמָה, *ḥōkhmāh*, and the nouns *הַחֵכְמָה, ḥōkhmāh*, *הַחֵכְמוֹת, ḥōkhmōth*, with something over 300 occurrences in the OT (of which rather more than half are in Job, Prov, and Eccl.). *Ḥōkhmāh*, accordingly, may be treated as the Heb equivalent for the Eng. "wisdom," but none the less the two words do not quite correspond. For *ḥōkhmāh* may be used of simple technical skill (Ex 28 3; 35 25, etc; cf Wisd 14 2; Sir 38 31; note that the EV gives a false impression in such passages), of military ability (Isa 10 13), of shrewdness applied to vicious (2 S 13 3) or cruel (1 K 2 9 Heb) ends, etc. Obviously no one Eng. word will cover all these different uses, but the general meaning is clear enough—"the art of reaching one's end by the use of the right means" (Smend). Predominantly the "wisdom" thought of is that which comes through experience, and the "wise man" is at his best in old age (Job 12 12; 15 10; Prov 16 31; Sir 6 34; 8 9; 25 3-6, etc; contrast Job 32 9; Eccl 4 13; Wisd 4 9; Sir 25 2). And in religion the "wise man" is he who gives to the things of God the same acuteness that other men give to worldly affairs (Lk 16 8). He is distinguished from the prophets as not having personal inspiration, from the priestly school as not

laying primary stress on the cultus, and from the scribes as not devoted simply to the study of the sacred writings. But, in the word by itself, a "wise man" need not in any way be a religious man.

In the RV Apoc and NT the words "wisdom," "wise," "act wisely," etc. are always tr'd of σοφός, *sophós*, or φρόνιμος, *phrónimos*, or of their cognates. For "wisdom," however, σοφία, *sophía*, is in almost every case the original word, the sole exception in the NT being Lk 1 17 (*φρόνησις, phrónēsis*). See also PRUDENCE.

(1) In the prophetic period, indeed, "wise" generally has an irreligious connotation. Israel was

fully sensible that her culture was beneath that of the surrounding nations, but thought of this as the reverse of a defect. Intellectual power without moral control was the very fruit of the forbidden tree (Gen 3 5), and "wisdom" was essentially a heathen quality (Isa 10 13; 19 12; 47 10; Ezk 28 3-5; Zec 9 2; specifically Edomite in Jer 49 7; Ob ver 8; contrast Bar 3 22.23) that deserved only denunciation (Isa 5 21; 29 14; Jer 4 22; 9 23; 18 18, etc). Certainly at this time Israel was endeavoring to acquire a culture of her own, and there is no reason to question that Solomon had given it a powerful stimulus (1 K 4 29-34). But the times were too distracted and the moral problems too imperative to allow the more spiritually-minded any opportunity to cultivate secular learning, so that "wisdom" in Israel took on the unpleasant connotation of the quality of the shrewd court counselors, with their half-heathen advice (Isa 28 14-22, etc). And the associations of the word with true religion are very few (Dt 4 6; Jer 8 8), while Dt 32 6; Jer 4 22; 8 9 have a satirical sound—"what men call "wisdom" is really folly!" So, no matter how much material may have gathered during this period (see PROVERBS), it is to the post-exilic community that we are to look for the formation of a body of Wisdom literature really associated with Israel's religion.

(2) The factors that produced it were partly the same as those that produced scribism (see SCRIBE). Life in Pal was lived only on the sufferance of foreigners and must have been dreary in the extreme. Under the firm hand of Persia there were no political questions, and in later times the nation was too weak to play any part in the conflicts between Antioch and Alexandria. Prophecy had about disappeared, fulfilment of the Messianic hope seemed too far off to affect thought deeply, and the conditions were not yet ripe that produced the later flame of apocalyptic enthusiasm. Nor were there vital religious problems within the nation, now that the fight against idolatry had been won and the ritual reforms established. Artistic pursuits were forbidden (cf esp. Wisd 15 4-6), and the Jewish temperament was not of a kind that could produce a speculative philosophy (note the sharp polemic against metaphysics, etc, in Sir 3 21-24). It was in this period, to be sure, that Jewish commercial genius began to assert itself, but there was no satisfaction in this for the more spiritually-minded (Sir 26 29). So, on the one hand, men were thrown back on the records of the past (scribism), while on the other the problems of religion and life were studied through sharp observation of Nature and of mankind. And the recorded results of the latter method form the Wisdom literature.

(3) In this are included Job, Prov, and Eccl, with certain Pss (notably 19, 37, 104, 107, 147, 148); in the Apoc must be added Sir and Wisd, with part of Bar; while of the other writings of the period parts of Philo, 4 Macc, and the Ahikar legend belong here also. How far foreign influence was at work it is hard to say. Egypt had a Wisdom literature of her own (see EGYPT) that must have been known to

some degree in Pal, while Babylonia and Persia could not have been entirely without effect—but no specific dependence can be shown in any of these cases. For Greece the case is clearer, and Gr influence is obvious in Wisd, despite the particularistic smugness of the author. But there was vitality enough in Judaism to explain the whole movement without recourse to outside influences, and, in any case, it is most arbitrary and untrue to attribute all the Wisdom speculation to Gr forces (as, e.g., does Siegfried, *HDB*).

The following characteristics are typical of the group: (1) The premises are universal. The writers draw from life wherever found, ad-

### 3. Religious mitting that in some things Israel may Basis

learn from other nations. The Proverbs of Lemuel are referred explicitly to a non-Jewish author (Prov 31 1 RVm), and Sir recommends foreign travel to his students (34 10, 11; 39 4). Indeed, all the princes of the earth rule through wisdom (Prov 8 16; cf Eccl 9 15). And even some real knowledge of God can be obtained by all men through the study of natural phenomena (Ps 19 1; Sir 16 29—17 14; 42 15—43 33; Wisd 13 2, 9; cf Rom 1 20).

(2) But some of the writers dissent here (Job 28; 11 7; Eccl 2 11; 8 16, 17; 11 5; Wisd 9 13[?]). And in any case this wisdom needs God's explicit grace for its cultivation (Sir 51 13—22; Wisd 7 7; 8 21), and when man trusts simply to his own attainments he is bound to go wrong (Prov 3 5—7; 19 21; 21 30; 28 11; Sir 3 24; 5 2, 3; 6 2; 10 12; Bar 3 15—28). True wisdom must center about God (Prov 15 33; 19 20f), starting from Him (Prov 1 7; 9 10; Ps 111 10; Sir 21 11; Job 28 28) and ending in Him (Prov 2 5); cf esp. the beautiful passage Sir 1 14—20. But the religious attitude is far from being the whole of Wisdom. The course is very difficult (Prov 2 4f; 4 7; Sir 4 17; 14 22, 23; Wisd 1 5; 17 1); continual attention must be given every department of life, and man is never done learning (Prov 9 9; Sir 6 18; Eccl 4 13).

(3) The attitude toward the written Law varies. In Eccl, Job and Prov it is hardly mentioned (Prov 28 7—9[?]; 29 18[?]). Wisd, as a special pamphlet against idolatry, has little occasion for specific reference, but its high estimate of the Law is clear enough (2 12—15; 18 9). Sir, esp., can find no terms high enough for the praise of the Law (esp. chs 24, 36; cf 9 15; 21 11, etc), and he identifies the Law with Wisdom (24 23—25) and claims the prophets as Wisdom teachers (44 3, 4). Yet this perverse identification betrays the fact that Sir's interest is not derived from a real study of the Law; the Wisdom that was so precious to him *must* be in the sacred books! Cf Bar 4 1 (rather more sincere).

(4) The attitude toward the temple-worship is much the same. The rites are approved (Prov 3 9; Sir 35 4—8; 38 11; Sir seems to have an especial interest in the priesthood, 7 29—33; 50 5—21), but the writers clearly have no theory of sacrifice that they can utilize for practical purposes. And for sacrifice (and even prayer, Prov 28 9) as a substitute for righteousness no condemnation is too strong (Prov 7 14; 15 8; 20 25; 21 3, 27; Sir 34 18—26; 35 1—3, 12; Eccl 5 1).

(5) An outlook on life beyond the grave is notably absent in the Wisdom literature. Wisd is the only exception (3 1, etc), but Gr influence in Wisd is perfectly certain. In Job there are expressions of confidence (14 13—15; 19 25—29), but these do not determine the main argument of the book. Prov does not raise the question, while Eccl and Sir categorically deny immortality (Eccl 9 2—10; Sir 14 16; 17 27, 28; 30 4; note that RV in Sir 7 17; 48 11 is based on a glossed text; cf the Heb). Even the Messianic hope of the nation is in the background in Prov (2 21, 22[?]), and it is altogether absent in Job and Eccl. To Sir (35 19; 36 11—14; 47 22) and Wisd (3 8; 5 16—23) it is important, however, but not even these works have anything to say of a personal Messiah (Sir 47 22[?]).

(6) That in all the literature the individual is

the center of interest need not be said. But this individualism, when combined with the weak eschatology, brought dire confusion into the doctrine of retribution (see SIN). Sir stands squarely by the old doctrine of retribution in this life: if at no other time, a man's sins will be punished on his deathbed (1 13; 11 26). Neither Job nor Eccl, however, are content with this solution. The latter leaves the problem entirely unsolved (8 14, etc), while the former commends it to God's unsearchable ways.

The basis of the Wisdom method may be described then as that of a "natural" religion respecting revelation, but not making much

### 4. Ideals

use of it. So the ideal is a man who believes in God and who endeavors to live according to a prudence taught by observation of this world's laws, with due respect, however, to Israel's traditional observances.

(1) From many standpoints the resulting character is worthy of admiration. The man was intelligent, earnest, and hard-working (Prov has a particular contempt for the "sluggard"; and cf Eccl 9 10). Lying and injustice are denounced on almost every page of the literature, and unceasing emphasis is laid on the necessity for benevolence (Ps 37 21; 112 5, 9; Job 22 7; 31 16—20; Prov 3 27, 28; 14 31; 21 13; 22 9; Eccl 11 1; Sir 4 1—6; 7 34, 35; 29 11—13; 40 24, etc). All of the writers feel that life is worth the living—at their most pessimistic moments the writers of Job and Eccl find attraction in the contemplation of the world. In Prov and Sir the outlook is even buoyant, Sir in especial being far from indifferent to the good things of life (30 23—25; 31 27; cf Eccl 2 24 and contrast Wisd 2 6—9).

(2) The faults of the Wisdom ideal are the faults of the postulates. The man is always self-conscious and self-centered. All intense enthusiasms are repressed, as likely to prove entangling (Eccl 7 16, 17 is the most extreme case), and the individual is always calculating (Sir 38 17), even among his friends (Sir 6 13; Prov 25 17) and in his family (Sir 33 19—23). Benevolence itself is to be exercised circumspectly (Prov 6 1—5; 20 16; Sir 12 5—7; 29 18), and Sir, in particular, is very far from feeling an obligation to love all men (25 7; 27 24; 30 6; 50 25, 26). So "right" and "wrong" become confused with "advantage" and "disadvantage." Not only is adultery wrong (Prov 2 17; Sir 23 23), but the injured husband is a dangerous enemy (Prov 5 9—11, 14; 6 34, 35; Sir 23 21). As a result the "moral perspective" is affected. With some of the finest moral observations in Prov and Sir are combined instructions as to table manners (Prov 23 1—3; Sir 31 12—18) and merely humorous observations (Prov 20 14), while such passages as Prov 22 22—28 and Sir 41 17—24 contain extraordinary conglomerations of disparate motives.

(3) So hope of earthly recompense becomes a very explicit motive (Prov 3 10; 11 25, etc; Wisd 7 8—12 is the best statement on the other side). Even though riches are nothing in themselves (Prov 10 2; 11 28; 23 4, 5; 28 11; Eccl 5 13; Sir 11 19; 31 5—7; all the literature denounces the unrighteous rich), yet Wisdom is to be desired as bringing not only righteousness but riches also (Prov 8 21; 11 25; 13 18; Sir 4 15; 20 27, 28; Wisd 6 21). This same desire for advantage gives an unpleasant turn to many of the precepts which otherwise would touch the highest point; perhaps Prov 24 17, 18 is the most extreme case: "Rejoice not when thine enemy falleth, . . . lest Jeh . . . turn away his wrath from him" (!)

(4) But probably the most serious fault was that the Wisdom method tended to produce a religious aristocracy (Sir 6 22, etc). It was not enough that

the heart and will should be right, for a long course of almost technical training was needed (the "house of instruction" in Sir 51 23 is probably the *school*; cf Prov 9 4). The uninstructed or "simple" (Prov 1 22, etc) were grouped quite simply with the "sinners"; knowledge was virtue and ignorance was vice. Doubtless Wisdom cried in the streets (Prov 1 20,21; 8 1-13; 9 1-6, almost certainly a reference to the canvassing efforts of the teachers for pupils), but only men of ability and leisure could obey the call to learn. And despite all that is said in praise of manual labor (Prov 12 11; 24 27; 28 19; Sir 7 15; 38 31,32,34), Sirach is merely frank when he says explicitly (38 25-34) that Wisdom cannot be for artisans (a carpenter as Messiah evidently would have been unthinkable to Sir; Mk 6 3). Scribism was at work along the same lines of development, and the final union of the Wisdom method with the scribal produced a class who called the common people accursed (Jn 7 49).

The statement of the methods and ideals of the Wisdom school is also virtually a statement of Our Lord's attitude toward it and an explanation of why much of His teaching of Christ took the form it did. As to the universality of the premises He was at

one with the Wisdom writers, one great reason for the universality of the appeal of His teaching. Almost everything in the life of the time, from the lily of the field to the king on his throne, contributed its quota to His illustrations. And from the Wisdom method also the form of His teaching—the concise, antithetical saying that sticks in the memory—was derived to some degree. (Of all the sayings of Christ, perhaps Lk 14 8-10—a quotation of Prov 25 6,7—comes nearest to the pure Wisdom type.) In common with the Wisdom writers, also, is the cheerful outlook, despite the continual prospect of the Passion, and we must never forget that all morbid asceticism was entirely foreign to Him (Lk 7 34 || Mt 11 19). With the self-conscious, calculating product of the Wisdom method, however, He had no patience. Give freely, give as the Father giveth, without regard to self, in no way seeking a reward, is the burden of His teaching, and such a passage as Lk 6 27-38 seems to have been aimed at the head of such writers as Sir. The attack on the religious aristocracy is too familiar to need recapitulation. Men by continual exercise of worldly prudence could make themselves as impervious to His teaching as by obstinate adherence to a scribal tradition, while His message was for all men on the sole basis of a desire for righteousness on their part. This was the true Wisdom, fully justified of her children (Lk 7 35; cf Mt 11 19), while, as touching the other "Wisdom," Christ could give thanks that God had seen fit to hide His mysteries from the wise and prudent and reveal them unto "babes" (Lk 10 21 || Mt 11 25).

(1) The remainder of the NT, despite many occurrences of the words "wise," "wisdom," etc, contains very little that is really relevant to the technical sense of the words. The one notable exception is Jas, which of the NT has even been classed as "Wisdom literature," and with some justice.

For Jas has the same appeal to observation of Nature (1 11; 3 3-6,11,12; 5 7, etc), the same observation of human life (2 2,3,15,16; 4 13, etc), the same antithetical form, and even the same technical use of the word "wisdom" (1 5; 3 15-17). The fiery moral zeal, however, is far above that of the other Wisdom books, even above that of Job.

(2) St. Paul, on the other hand, belongs to an entirely different class, that of intense religious experience, seeking its premises in revelation. So the Wisdom method is foreign to him and the

absence of Nature illustrations from his pages is notorious (even Rom 11 17 is an artificially constructed figure). Only one passage calls for special comment. The "wisdom" against which he inveighs in 1 Cor 1-3 is not Jewish but Gr-speculation in philosophy, with studied elegance in rhetoric. Still, Jewish or Gr, the moral difficulty was the same. God's message was obscured through an overvaluation of human attainments, and so St. Paul's use of such OT passages as Isa 29 14; Job 5 13; Ps 94 11 (in 1 Cor 1 19; 3 19,20) is entirely just. Against this "wisdom" St. Paul sets the doctrine of the Cross, something that outraged every human system but which, all the more, taught man his entire dependence on God.

(3) Yet St. Paul had a "wisdom" of his own (1 Cor 2 6), that he taught to Christians of mature moral (not *intellectual*: 3 1-3) progress. Some commentators would treat this wisdom as doctrinal and find it in (say) Rom; more probably it is to be connected with the mystical experiences of the Christian whose life has become fully controlled by the Spirit (1 Cor 2 10-13). For religious progress is always accompanied by a higher insight that can never be described satisfactorily to persons without the same experience (2 14).

(1) One characteristic of the Wisdom writers that proved of immense significance for later (esp.

Christian) theology was a love of rhetorical personification of Wisdom (Prov 7 12-33; 8 1-9 6; Sir 4 11-19; 6 23-31; 14 20-15 10; 24; 51 13-21; Wisd 6 12-9 18; Bar 3 29-32). Such personifications in themselves are not, of course, remarkable (cf e.g. the treatment of "love" in 1 Cor 13), but the studied, somewhat artificial style of the Wisdom writers carries out the personification with a curious elaboration of details: Wisdom builds her house, marries her disciple, mingles wine, etc. The most famous passage is Prov 8 22-31, however. The Wisdom that is so useful to man was created before man, before, indeed, the creation of the world. When the world was formed she was in her childhood, and while God formed the world she engaged in childish play, under His shelter and to His delight. So ver 30 should be rendered, as the context makes clear that *'mwn* should be pointed *'āmūn*, "sheltered," and not *'āmōn*, "as a master-workman." And "Wisdom" is a quality of man (8 31-36), not a quality of God.

(2) Indeed, "Wisdom" is an attribute rarely predicated of God in the OT (1 K 3 28; Isa 10 13; 31 2; Jer 10 12; 51 15; cf Dnl 5 11), even in the Wisdom writers (Job 5 12 ff; 9 4; Ps 104 24; Prov 3 19). Partly this reticence seems to be due to a feeling that God's knowledge is hardly to be compared in kind to man's, partly to the fact that to the earlier writers "Wisdom" had a profane sound. Later works, however, have less hesitation in this regard (e.g., Sir 42 21; Bar 3 32, the MT pointing and LXX of Prov 8 30), so that the personifications became personifications of a quality of God. The result was one of the factors that operated to produce the doctrine of the "Word" as it appeared in the *Palestinian* form (see *Logos*).

(3) In the Apoc, however, the most advanced step is taken in Wisd. Wisdom is the only-begotten of God (7 22), the effulgence of eternal light (7 26; cf He 1 3), living with God (8 3) and sharing (?) His throne (9 4). She is the origin (or "mother") of all creatures (7 12; cf 8 6), continually active in penetrating (7 24), ordering (8 1), and renewing (7 27) all things, while carrying inspiration to all holy souls (7 23), esp. to Israel (10 17, 18). Here there is no doubt that the personification has ceased to be rhetorical and has become real. Wisdom is thought of as a heavenly being, not so distinctively personal, perhaps, as an angel, but none the less far more than a mere rhetorical term; i.e. she is a "hypostasis."

(4) Most of Wisd's description is simply an expansion of earlier *Palestinian* concepts, but it is evident that other influence has been at work also and that that influence was *Greek*. The writer of Wisd was touched genuinely by the Gr philosophy, and in 7 24, at any rate, his "Wisdom" is the *logos spermatikós* of the Stoics, with more than suspicions of Gr influence elsewhere in the descriptions. This combination of Jewish

and Gr thought was still further elaborated by Philo— and still further confused. For Philo endeavored to operate with the Wisdom doctrine in its Palestinian form, the Wisdom doctrine into which Wisd had already infused some Logos doctrine, and the Logos doctrine by itself, without thoroughly understanding the discordant character of his terms. The result is one of the most obscure passages in Philo's system. Sometimes, as in *De Fug.* §109, ch xx, Wisdom is the mother of the Logos, as God is its Father (cf *Cherub.*, §§49, 50, ch xiv), while, again, the relation can be inverted almost in the same context and the Logos appears as the source of Wisdom (*De Fug.* §97, ch xviii). See LOOS.

(5) Philo's influence was incalculable, and Wisdom, as a heavenly power, plays an almost incredible rôle in the gnostic speculations of the 2d and 3d cents., the gnostic work *Pistis Sophia* probably attaining the climax of unreality. The orthodox Fathers, however, naturally sought Wisdom within the Trinity, and Irenaeus made an identification with the Holy Spirit (iv. 20. 3). Tertullian, on the other hand, identified Wisdom with the Son (probably following earlier precedent) in *Adv. Prax.*, 7, and this identification attained general acceptance. So Prov 8 22-30 became a *locus classicus* in the Christological controversies (an elaborate exposition in Athanasius, *Orat.* ii.16-22), and persisted as a dogmatic proof-text until a very modern period.

LITERATURE.—The OT Theologies, particularly those of Smend, ed 2 (1899), and Bertholet (1911). For the intermediate period, *GJV*, III, ed 4 (1909), and Bousset, *Die Religion des Judentums*, ed 2 (1906). Special works: Toy, "Wisdom Literature," *EB*, IV (1903); Meinhold, *Die Weisheit Israels* (1908); Friedländer, *Griechische Philosophie im AT* (1904, to be used cautiously). On Philo, cf esp. Drummond, *Philo Judaeus*, II, 201-13 (1888). See also the arts. on the various books and of Logos; PHILO JUDEUS.

BURTON SCOTT EASTON

WISDOM LITERATURE, lit'ér-a-tûr. See preceding article.

WISDOM OF GOD (σοφία, *sophía*): Lk 11 49 reads: "Therefore also said the wisdom of God, I will send unto them prophets and apostles; and some of them they shall kill and persecute." The patristic and many later commentators, on the basis of the parallel in Mt 23 34, took "wisdom of God" here to be a self-designation of Christ—an interpretation, however, that is obviously impossible. Somewhat similar is the view (Meyer) that treats the words as a Lukan designation of Christ, with the assumption that Luke here reintroduces Christ as the speaker in order to give solemnity to the judgment pronounced. But this is incredibly awkward and has no parallel in the Lukan use for even more solemn passages. Much simpler is the interpretation (Hofmann, B. Weiss, Plummer) that regards Christ as announcing here a decree formed by God in the past. But it is the behavior of the present generation that is in point (cf Lk 13 8.9; 20 13; altogether different is Lk 10 21). And the circumstantial wording of what follows is inappropriate for such a decree, is without parallel in Christ's teaching, and implies rather a *written* source. In the OT, however, no passage exists that resembles this (Prov 1 20-31 [so Godet] is quite out of the question). So many exegetes (Holtzmann, J. Weiss, Loisy, Harnack) find here a quotation from some lost source that Our Lord approved and that was familiar to His hearers. This is certainly the most natural explanation. Nor can it be said to be impossible that Christ recognized genuine prophetic inspiration in some writing that was meant to have transitory value only and not to be preserved for future generations. Perhaps this bore the title "Wisdom of God" or represented "Wisdom" as speaking, as in Prov 1 22-33.

BURTON SCOTT EASTON

WISDOM OF JESUS. See SIRACH.

### WISDOM OF SOLOMON, THE:

- I. NAME
- II. CANONICITY
- III. CONTENTS
  - 1. The Wisdom Section
  - 2. The Historical Section
- IV. LITERARY FORM

### V. UNITY AND INTEGRITY

- VI. TEACHING
  - 1. Theology
  - 2. Anthropology
  - 3. Deontology
  - 4. Hamartiology
  - 5. Soteriology
  - 6. Eschatology

### VII. AIM

### VIII. AUTHOR

### IX. DATE

- 1. Literary
- 2. Historical
- 3. Philosophical

### X. ORIGINAL LANGUAGE

### XI. USE OF WISDOM BY CHRISTIAN WRITERS

### XII. TEXT AND VERSIONS

- 1. Latin
- 2. Syriac

### LITERATURE

**I. Name.**—In the Gr MSS (B A S, etc) the book is called "The Wisdom of Solomon" (Σοφία Σαλωμῶνος, *Sophia Salōmōnos*, the form of the latter word varying in the best MSS). In the Syr (Pesh) its title is "The Book of the Great Wisdom of Solomon" (Solomon was among the Jews and the early Christians the patron of didactic, as David was of lyrical, and Moses of religious-legal, literature, and their names came to be associated with literary compositions with which they had nothing to do. We read in the OT of the wisdom of Solomon (1 K 3 7-14; cf Sir 47 12-18 [14-19]), and the whole of the Book of Prov is called by his name, though he is at most the author of but a part. Solomon speaks in the first person in this book (chs 6-9), as he does in Eccl (1 12 ff), for that he is made the speaker until the close of ch 9 is made certain by 7 1 ff; 9 2 ff. As long as he was thought to be the composer of this book it continued to be called "The Wisdom of Solomon" among the Jews and the early Christians.

Influenced by the Gr thought and style of the book, Jerome came to the conclusion that Solomon was not its author and he accordingly altered its title to "The Book of Wisdom" (*Liber sapientiae*), and it is this designation that the book bears in the Vulg and the VSS made from it, though in the Protestant trs (Ger., Eng., Welsh, etc) the title "The Wisdom of Solomon" is continued, as these follow the Gr VS and not the Lat. Luther's title is "The Wisdom of Solomon to Tyrants" (*Die Weisheit Salomos an die Tyrannen*). Epiphanius and Athanasius quote the book under the name "All-Virtuous Wisdom" (Πανἀρετος Σοφία, *Pandretos Sophia*), a title by which Prov and Sir are also known in the writings of some of the Fathers.

**II. Canonicity.**—In the MSS and edd of the Gr Bible and in the Vulg, EV, etc, Wisd follows Prov, Eccl and Cant, and is followed by Sir. Some of the Fathers, believing the book to be by Solomon, thought it Divinely inspired and therefore canonical; so Hippolytus, Cyprian, Ambrose, etc. Other Fathers, though denying the Solomonian authorship of the book, yet accorded it canonical rank; so Origen, Eusebius, Augustine, etc. On the other hand there were some in the early church who refused to acknowledge the book as in any way authoritative in matters of doctrine. The Council of Trent included it with the rest of the Protestant Apoc (except 1 and 2 Esd and Pr Man) in the Canon, so that the Romanist Bible includes, but the Protestant Bible excludes, it.

**III. Contents.**—The book is made up of two main parts so different as to suggest difference of authorship. (1) *The wisdom section* (1 1-11 4): In this part the writer describes and commends Wisdom, warning his readers against neglecting it. (2) *The historical section* (11 5-19 22).

(1) *Righteousness* (i.e. Wisdom in operation) leads to immortality, unrighteousness to death (ch 1).

(2) *Contrasted fortunes of the wise (righteous) and unwise (ungodly)* (2 1-6 21).—(a) Sensual pleasures issue in death while God intended all men to live spiritually (ch 2); (b) the lot of the wise (righteous) is a happy one. Their sufferings are

disciplinary and remedial; they shall live forever and reign hereafter over the nations (Gentiles)

(3 1-9); (c) but the lot of the wicked and of their children is a miserable one; the wise (righteous) shall be happy though childless (3 10-19); (d) virtuous childlessness secures immortality before guilty parenthood (4 1-6); (e) though the wise (righteous) die early, yet they have rest in their death, and accomplish their life mission in the allotted time (cf Enoch) (4 7-14); (f) the ungodly (unwise) shall come to a wretched end: then they shall see and envy the prosperity of the righteous. Though they shall pass tracelessly away, the righteous shall rejoice in a life that is endless (4 15-5 23); (g) kings ought therefore to rule according to Wisdom and thus attain to immortality (6 1-21).

(3) *Wisdom*.—Speaking in the name of Solomon, the writer praises Wisdom and commends it to kings ("judges"="rulers" in 6 1, is but a synonym) (6 1-11 4). (a) All men come into the world with the same universal need of Wisdom which leads to true kingship and immortality (6 1-25); (b) I (Solomon) sought Wisdom as the main thing and in obtaining it had along with it every good thing, including knowledge of every kind (7 1-8 21); (c) the prayer which Solomon offered for Wisdom (9 1-18); (d) how Wisdom defended the heroes of Heb history, from the first man, Adam, to the Israelites at the Red Sea and in the wilderness (10 1-11 4).

In this second part of the book Solomon no longer speaks in the first person (as in chs 6-9), nor is Wisdom once mentioned or for certain referred to, though most writers see in this part the attempt of the author of 1 1-11 4 to exemplify in concrete instances the working of that Wisdom of which in the first part he describes the nature and issues.

(1) Contrasted treatment by God (not Wisdom) of the Israelites and their foes (11 5-12). By what things their foes were punished they were benefited (11 5). (a) The Egyptians (11 5-12 2): Water a boon to Israel, abane to Egypt (11 6-14). The Egyptians punished by the animals they worshipped (11 15-20), though there was a relenting on God's part that sinners might repent (11 21-12 2). (b) The Canaanites (12 3-27): The abominations of the worship and the Divine punishment with the lessons this last teaches.

(2) Idolatry described and condemned (chs 13-15). These chapters form a unity in themselves, a digression from the historical survey closed with 12 27 and continued in 16 1-19. The digression may of course be due to the allusion in 11 5-12 to the sins of the Egyptians and Canaanites. Kinds of idolatry: (a) Nature-worship (fire, wind, air, water, heavenly bodies), due often to sincere desire to find out God (13 1-9); (b) worship of idols in animal form, a much grosser sin (13 10-19); (c) God's indignation against all forms of idolatry (14 1-11); (d) origin of image-worship (14 15-21); the father mourning for his deceased son makes an image of him and then worships it (14 15); rulers are often flattered and then deified (14 16 f); artists often make images so attractive as to tempt men to regard them as gods (14 18-21); (e) immoral results of idolatry: "The worship of idols . . . a beginning and cause and end of every evil" (ver 27) (14 22-31); (f) Israel was free from idolatry and in consequence enjoyed the Divine favor (15 1-5); (g) the folly of idolatry: the image man made less capable than man its maker and worshipper; the Egyptians the worst offenders (15 6-19).

(3) In five different respects the fortunes of Egypt and Israel in the past are contrasted. Nature using similar means to punish the Egyptians and to reward the Israelites (16-19 22), viz. in respect of the following: (a) animals, quail (vs 1-4) and fiery serpents (vs 5-14) (16 1-14); (b) fire and water, heat and cold (16 15-29); (c) light and darkness (17 1-18 4); (d) death (18 5-25); (e) passage of the Red Sea (19 1-22).

**IV. Literary Form.**—There is not so much manifest poetry in this book as in Sir, though there is a large amount of genuine poetry characterized by parallelism, but not by meter in the ordinary sense of the term. In parts of the book, which must be pronounced prose, parallelism is nevertheless often found (see 10 1 ff). There are far fewer epigram-

matic sentences in Wisd than in Sir, but on the other hand there is a far greater number of other rhetorical devices, assonances (1 10; 4 2; 5 15; 7 13), alliterations (2 23; 5 12.18; 6 11; 12 15), antitheses (13 18 f), etc. See for details *Speaker's Apoc* (Farrar), I, 404 ff.

**V. Unity and Integrity.**—Nearly all writers on the book believe it to be one homogeneous whole, the work of one mind. They point for proof to the fact that the whole book is a consistent whole directed against the two evils, apostasy and idolatry; that the language is from beginning to end uniform, such as one writer would be likely to employ.

For a statement of contrary views and a reply to them see the *Comm.* of Grimm, pp. 9-15. Until about the middle of the 18th cent. no doubt had been expressed as regards the unity of the book. (1) Houbigant (*Notae criticae in universos NT libros*, 1777, 169) divided the book into two parts: chs 1-9 written by Solomon in Heb, chs 10-19 composed in Gr at a later time, perhaps by the tr into Gr of chs 1-9. Against the Solomonian authorship see VIII, below, and against a Heb original see X, below. Doederlein adopted Houbigant's division of the book, denying, however, the Solomonian authorship. (2) Eichhorn (*Einleitung in das NT*, 142 ff) divided the book also into two parts: chs 1-11 and 11 2-19. He held that the whole was composed in Gr by two different writers or by the same writer at different times. (3) Nachtigal (*Das Buch der Weisheit*, 1799) went much farther, holding that the book is nothing more than an anthology, but he has had no followers in this. (4) Bretschneider (*De lib. Sap.*, 1804) ascribes the book to three principal authors and to a final editor. 1-6 8 was composed in Heb in the time of Antiochus Epiphanes (d. 164 BC) by a Palestinian Jew, though it is an excerpt from a larger work; 6 9-10 is the work of an Alexandrian Jew, a contemporary of Our Lord; ch 11 was inserted by the final editor as seemingly necessary to connect parts 2 and 3; chs 12-19 were written about the same time by a Jewish partisan of slender education and narrow sympathies.

*Summary.*—Perhaps, on the whole, the arguments in favor of the unity of the book outweigh those against it. But the evidence is by no means decisive. The Wisdom section (1 1-11 4) is a much finer bit of writing than the rest of the book, and it bears the general characteristics of the Wisdom literature. Yet even within this larger unity chs 6-9 stand out from the rest, since only in them is Solomon made to speak in the first person (cf Eccl 1 12 ff); but these four chapters agree with the rest of the Wisdom section in other respects. Within the historical section (11 5-19 22) chs 13-15 stand together as if a separate treatise on idolatry (see III, above), though if originally independent an editor has logically joined ch 15 to ch 12; cf "for" (γάρ, γάρ), "etc" (13 1). Indeed the book in its present form is made at least externally one, though it is not absolutely certain whether or not this external unity is due to editorial revision. Some scholars have maintained that the book as it stands is a torso (so Eichhorn, etc). Calmet infers this from the fact that the historical sketch closes with the entrance of the Israelites into Canaan. Others say that the writer's sketch was cut short by some unforeseen event (Grotius, Eichhorn), or that the remainder of the once complete work has been lost in transmission (Heydenreich). But on the other hand it must be remembered that the writer's record is limited by his purpose, and that the history of the Egyptians supplies an admirable and adequate illustration of the wickedness and calamitous results of unfaithfulness to God and His law.

**VI. Teaching.**—In the treatment of this section it is assumed with some hesitation that the book is throughout the work of one man. The following is a brief statement of the teaching of this book concerning theology, anthropology, deontology, hamartiology, soteriology, and eschatology.

Theology in the strict sense, i.e. the doctrine about God: God is incomparably powerful (11 21 f), omnipresent (1 7; 12 1) and all-loving (11 24). He made the world out of formless matter (11 17, the

doctrine of the Alexandrian Judaism). He did not create the world out of nothing as the OT (Gen 1 1 ff) and even Sir teach (see SIRACH, 1. Theology Book of, IV, 1). The author's highest conception of creation is the conversion of chaos into cosmos. It is the order and beauty of the universe that amaze the writer, not the stupendous power required to make such a universe out of nothing (11 20; 13 3). Though God is said to be just (12 15), kind (1 13; 11 17-26; 12 13-16; 15 1; 16 7), and is even addressed as Father (14 3), yet He is in a unique sense the Favored and Protector of Israel (16 2; 18 8; 19 22); yet according to 12 2-20 even the calamities He heaps up upon the foes of Israel were designed to lead them to repentance (12 2-20), though in chs 11 f we are clearly taught that while the sufferings of the Israelites were remedial, those of their enemies were purely penal. The conception of God in Wisd agrees on the whole with that of Alexandrian Judaism (c 100 BC); i.e. it lays principal stress on His transcendence, His infinite aloofness from man and the material world. We have therefore in this book the beginning of the doctrine of intermediaries which issued in Philo's *Powers*, the media through which the Absolute One comes into definite relation with men.

(1) *Spirit of the Lord*.—In Wisd as in the later books of the OT (exilic and post-exilic), the expression "the Spirit of the Lord" denotes the person of God. What God does is done by the Spirit. Thus it is His Spirit that fills and sustains the world, that observes all human actions (1 7 f), that is present everywhere (12 1). Wisdom does not hypostatize "the Spirit of the Lord," making it an intermediary between God and His creatures, but the way is prepared for this step.

(2) *Wisdom*.—Much that is said of the Spirit of the Lord in this book is said of Wisdom, but much more, and there is a much closer approach to hypostatization in the case of Wisdom. At the creation of the world Wisdom was with God (cf Prov 8 22-31), sat by His throne, knew His thoughts and was His associate (8 3; 9 4.9), made all things, taught Solomon the Wisdom for which he prayed (7 22); all powerful, seeing all things (7 23), pervading all things (7 24), an effluence of the glory of the Almighty (7 25); she teaches sobriety, understanding, righteousness and courage (8 7, the four cardinal virtues of the Stoic philosophy). For detailed account of the conception of Wisdom in this book see WISDOM.

(3) *The Logos*.—In Philo the Logos is the intermediary power next to Deity, but in Wisd the term keeps to the OT sense, "word," that by which God addresses men. It never means more, though some hold (Girörer, *Philo*, etc, I, 225 ff) that in Wisd 9 1 f; 12 9; 16 12; 18 22, Logos has the technical sense which it bears in Philo; but a careful examination of the passages shows that nothing more than "word" is meant (see LOGOS). The only other superhuman beings mentioned in the book are the gods of the Gentiles which are distinctly declared to be nonentities, the product of man's folly (14 13 f), and the devil who is, however, but once referred to as identical with the serpent of Gen 3. The book does not once speak of a Canon of Scripture or of any Divine revelation to man in written form, though it often quotes from the Pent and occasionally from Isa and Pss, never, however, naming them. Wisd is thus much more universalistic and in harmony with Wisdom literature than Sir, which identifies Wisd with the Law and the Prophets and has other distinctly Jewish features.

In its psychology Wisd follows the dichotomy of Platonism. Man has but two parts, soul and body (1 4; 8 19 f; 9 15), the word soul (*ψυχή*, *psuchē*)

including the reason (*νοῦς*, *nous*) and the spirit (*πνεῦμα*, *pneuma*). Wisd 15 11 is the only passage which seems to teach the doctrine of

2. **Anthropology** the trichotomy of man, but in reality it does nothing of the kind, for the parallelism shows that by "soul" and "spirit" the same thing is meant. Philo teaches the same doctrine (see Drummond, *Philo*, etc, I, 316 ff). Man's soul is breathed into the body (15 11; cf Gen 2 7) and taken back again by God (15 8). The writer adopts the Platonic theory of the pre-existence of souls (8 20; cf 15 8.11.16), which involves the belief in a kind of predestination, for the previous doings of the soul determine the kind of body into which it enters. Solomon's soul, being good, entered an undefiled body (8 20). R. H. Charles (*Eschatology*, etc, 254 f) is hardly correct when he says that according to Wisd (1 4; 9 15, etc) matter is inherently sinful. This doctrine was definitely taught by Philo, who accepted Heraclitus' epigram, *σῶμα σῆμα*, *sōma sēma*, "The body is a tomb." So it is said (12 10; 13 1) that man is by nature evil, his wickedness being inborn. But if he sins it is his own affair, for he is free (1 16; 5 6.13). The writer borrows two words from Gr poetry and philosophy which appear to involve a negation of human freedom, viz. *ἀνάγκη*, *anágkē*, "necessity" and *δίκη*, *dikē*, "justice," "avenging justice." The first blinds the eyes of the ungodly (17 17), but the blindness is judicial, the result of a course of evil (see 19 1-5). The second term is used in Gr philosophy in the sense of *nemesis*, and it has that sense in Wisd 1 8, etc. But throughout this book it is assumed that punishment for sin is deserved, since man is free. The author of Wisd believes in a twofold division into good (wise) and bad (ungodly), and, unlike the writers of the later parts of the OT, he holds it possible for a person to pass from one class into another. But does not God, according to parts of Wisd, as of the OT, appear to show undue favoritism to Israel and neglect of other people? Thus Israel is "God's Son" (18 13), His children (sons, 12 19.21; 16 10.26), His sons and daughters (9 7). They are His holy and elect ones (3 9; 4 15; and esp. 10 17; 18 1.5). But the Israelites were treated as they were, not because they were Israelites, but because they were morally better than the nations around (see Drummond, *op. cit.*, II, 207 ff).

Under the term "deontology" here, religious and ethical practice is included. (1) As might be expected in a Wisdom book, little importance is attached to the Law of Moses and its requirements.

3. **Deontology** Though historical allusions are made to the offering of sacrifices, the singing of psalms and the taking upon themselves of the obligation of the covenant of the Law (18 9); though, moreover, reference is made to the offering of incense by Aaron (18 21), and Solomon is made to utter the words "temple," "altar," "tabernacle" (9 8), yet in other respects nothing is said of the temple and its feasts, of the priesthood, of sacrifice, or of the laws of clean and unclean. Yet the duty of worshipping the one true God and Him only and the evil results of worshipping idols are strongly and constantly insisted upon, esp. in the second or historical part of the book (11 5 to end). (2) The cardinal virtues inculcated are those of the Stoic philosophy, viz. prudence (*σοφροσύνη*, *sōphrosūnē*), common-sense (*φρόνησις*, *phrōnēsis*), justice (*δικαιοσύνη*, *dikaiosūnē*) and courage (*ἀνδρεία*, *andrela*), showing that the writer was influenced by the philosophy of the Greeks.

As a historical fact, the writer adopts the account in Gen 3 of the entrance of sin into the world. "By the envy of the devil death [i.e. as the

4. **Hamar-tiology** connection proves, spiritual death] entered into the world" (2 24). In 14 27, however, sin is made to have its root in idolatry, meaning perhaps that all sin consists in not giving proper heed to the one true God, and that the moral monstrosities of his time were outgrowths of idolatrous worship. The free-

dom of the will is taught explicitly or implicitly throughout the book (see above VI, 2).

The book is silent as to a Messiah who shall deliver His people. It is Wisdom that saves man:

“Because of her I shall have immortality” (8 13); immortality lies in kinship to Wisdom (8 17); all who give heed to the commands of Wisdom have the assurance of incorruption, and incorruption brings men near to God (6 18 f). The knowledge of God’s power is the root of immortality (15 2).

The doctrine of individual immortality is explicitly taught in this book. Man (=all men) was created

for incorruption (2 23; 6 19; 12 1).

**6. Eschatology**—The righteous have the full hope of immortality (3 4) and shall live forever (5 15). When the wicked die they have no hope (3 18), since they suffer for their sins in this present world as well as in that which is to come (3 16, 18). The doctrine of a resurrection of the body is not taught. If the author accepted Philo’s doctrine of the inherent sinfulness of matter (see above VI, 2), as R. H. Charles holds, he could not believe in a bodily resurrection. After death there is to be a day of decision (*δᾱγῶσις, διάγνῶσις*, the word used in Acts 25 21; see 3 18); there will be an examination (*ἐξέτασις, ἐπέτασις*) into the counsels of the ungodly. The sins of the wicked shall be reckoned up (4 20), but the righteous man shall stand in great boldness before the face of them that afflicted him (5 1). The teaching of the book as to the future of the righteous does not seem to be consistent. According to 3 1 f, the righteous pass at death immediately into the bliss of God; but the teaching of 4 20 f is that the wicked and the righteous shall be assembled in one place to receive their sentence.

**VII. Aim.**—The writer’s purpose appears to have been to recommend to his fellow-countrymen in Alexandria the claims of religion under the names of Wisdom, Righteousness, etc, and to warn them against falling into the idolatry of the Egyptians. In addition to glorifying Wisdom, he gives an ironical account of the rise of idolatry, and he uses strong language in pointing out the disastrous consequences in this world and the next of a life away from the true God (see above, III). The book is ostensibly addressed to rulers, but they are mentioned only in 6 1–11.20–25, and the appeal of the book is to men as such. In addressing rulers the author uses a rhetorical device. It might be argued that if rulers with their superior advantages need such exhortations and warnings, how much more ordinary men!

Plumptre (*Ecclesiastes*, 70) and Siegfried (*HDB*, IV, 928) contend that the Solomon of this book is made to answer the Solomon of Eccl. But the author does not show any acquaintance with Eccl, and it is hardly likely that this last book was known at the time in Alexandria, for though composed about 200 BC, it was not put into Gr for a long time afterward. Besides, there is nothing about idolatry in Eccl. The conclusion reached in the genuine parts of this last book is a counsel of despair: “All is vanity.” A reply to that book would seek to show that life is worth living for the sake of the present and the future. The Book of Wisdom denounces idolatry in the most scathing language: how can this and the like be a polemic against Eccl?

**VIII. Author.**—The author was an Alexandrian Jew, well read in the LXX whose phrases he often uses, fairly acquainted with Gr philosophy as taught at Alexandria and also with physical science as known at the time (see 7 17–20; 8 8). He was beyond all doubt a Jew, for the views he advocates are those of an enlightened but strong Judaism; his interests are even narrowly Jewish (note the

fiercely anti-gentile sentiments of 11 10–13, 17–23), and his style is largely tinged by the vocabulary and the phraseology of the Gr VS of the Heb Scriptures. That he was an Alexandrian or at least an Egypt Jew is equally probable. No Palestinian could have written the language of this work with its rhetorical devices (see above, IV), or have displayed the acquaintance which the book reveals with Gr philosophy as modified by Jewish-Alexandrian thought.

**Other views.**—These include: (1) that Solomon is the author: see above, II. No modern scholar takes this view seriously, though singularly enough it has been revived by D. S. Margolouth; (2) that Zerubbabel is the author (J. M. Faber); (3) that the author was one of the translators of the LXX; (4) that the author belonged to the Therapeutae: so Grfärer (*Philo*, II, 265), Dähne (*Philo*, II, 270); cf Jost (*Geschichte des Judentums*, I, 378). This has been inferred from 16 28, the Therapeutae being, it is said, a Jewish sect which, like the Zarathustrians, worshipped toward the rising sun. But we know very little about this sect, and there is no decisive evidence that it ever existed. If, however, Eusebius (*HE*, II, 17) is right in saying that Philo’s Therapeutae were Christians (the earliest Christian sect of Alexandria), it is clear that no member of this sect wrote Wisd, for the book is wholly free from Christian influence; (5) that Ben Sira is the author (Augustine); (6) that Apollon is the author: so Noack (*Der Ursprung des Christenthums*, I, 222); Plumptre (*Expos*, I, 329 ff, 409 ff); see summary of grounds in *Speaker’s Apoc* (Farrar), I, 413 ff; but the author must have been a Jew and he wrote too early to allow of this hypothesis; (7) that Philo is the author: thus Jerome writes (*Praef. in lib. Sol.*): *Nonnulli scriptorum hunc esse Judaei Philonis affirmant*. This view was supported by Luther and other scholars; cf the Muratorian Fragment (in Zahn’s text) in XI, below. But the teaching of this book represents an earlier stage of Alexandrian Jewish speculation than that found in Philo’s works, and the allegorical method of interpretation so rampant in the latter is almost wholly absent from Wisd. (8) It has been held by some (Kirschbaum, Weiss, etc) that whoever the author was he must have been a Christian, but the whole trend and spirit of the book prove the contrary.

**IX. Date.**—The book was probably composed about 120–100 BC. The evidence is literary, historical and philosophical.

The book must have been written after the LXX VS of the Pent and Isa had been made, since the author has evidently used this VS of

**1. Literary** both books and perhaps of the Pss as well (cf 3 1 and Ps 31 5[6]; and also 15 15 f and Ps 115 4–7 [=Ps 135 15–18]). Now we know from Sir (Prol.) that the LXX of the Pent, the Prophets and of at least a portion of the Writings (Hagiographa) was completed by 132 BC, when the younger Siracide finished his tr of Sir (see SIRACH, Book of, VIII). It may therefore be inferred that Wisd was written after 132 BC. Moreover, in 4 1 the author shows an acquaintance with Sir 16 1–4 in Gr, for the pseudo-Solomon does not seem to have known Heb, or he would sometimes at least have quoted from the Heb text. This confirms the conclusion drawn from the use of the LXX that this book is at least as late as, say, 130 BC, and almost certainly later. The book was composed earlier than any of the NT writings, or some of the latter would have been quoted or referred to. Moreover, it may be assumed that the Gr Canon was complete in the time of Our Lord, and thus included Wisd as well as the rest of the OT Apoc. But see *International Journal of Apocrypha*, October, 1913, p. 77, art. by the present writer. It must have taken a long time after writing for the book to gain the respect which secured its canonization. A date 100 BC agrees with all the facts.

Wisd 3 1; 5 1; 6 5–9 imply that at the time of writing the Jews addressed were suffering under the lash of persecution, and we have the resulting feeling of animosity against the Egyptians, the persecuting power, expressed in 11 16–19. Now we know that the early Ptolemies treated the Jews with consideration, and Ptolemy VII (Physcon, 145–117 BC)

was the first to adopt a contrary policy toward the Jews of Egypt, owing to the support they had given to Cleopatra. Jos (*Cap*, II, 5) gives an account of the vengeance which this king wreaked upon the Jews of Alexandria at this time. Nevertheless, the literary manner and the restrained spirit with which these matters are referred to show that the writer is describing a state of things which belongs to the past, though to a recent past. A date about 100 BC would admirably suit the situation of the author at the time of composition.

The teaching of the book (see above, VI) belongs to that stage in the development of Alexandrian Judaism which existed about 100 BC.

**3. Philo-sophical** We have not in this book the allegorization characteristic of Philo (b. 20 BC, d. 40 AD), nor had his Logos-doctrine as yet become a part of the creed of Alexandrian Jews.

**X. Original Language.**—Scholars are practically agreed that the book was composed in Gr. D. S. Margoliouth attempted to prove a Heb original (*JRAS*, 1890, 263-97; see reply by Freudenthal, *JQR*, III, 722-53), but the evidence he offers has convinced nobody.

(1) The Gr of Wisd is free, spontaneous and idiomatic. There are a few Hebraisms, but only such as characterize Hel Gr in general; Wisd is very different in this from Sir which abounds with Hebraisms, due no doubt to tr from a Heb original. (2) The rhetorical devices so common in the Gr of the book can be due only to the original text; they could hardly occur in such profusion in a tr. In addition to those mentioned above in IV, note the Gr rhetorical figures *chiasmus* (1 1-4 8; 3 15) and *seribes* (6 7-20). (3) The tr of Sir into Heb before the discovery of the Heb fragments had been often attempted and found comparatively easy; but it is very difficult to put Wisd into Heb because the style is so thoroughly Greek. (4) No trace of a Heb original has thus far been found. What Nachmanides saw was not the original Heb, but a tr in Heb from the original text. Jerome (*Praef. in lib. Sol.*) says that though he had himself seen Sir in Heb, a Heb text of Wisd was not to be found.

**XI. Use of Wisd by Christian Writers.**—It has been thought that the following parts of the NT have been influenced by Wisd: Lk 2 7 (cf Wisd 7 4); Lk 12 20 (cf Wisd 15 8); Lk 9 31 (cf Wisd 3 2); Lk 19 44 (cf Wisd 3 7). The "Logos"-doctrine of John (see Jn 1 1, etc) has certainly a connection with the doctrine of Wisdom in Wisd (see Gregg, *Comm.*, livf). Grafe (*Theologische Abhandlungen*, Freiburg in B., 1892) endeavors to prove that Paul made large use of Wisd (see also Sanday and Headlam, *Romans*, 51 f, 267-69); but this has been denied; see further Deane (*Comm.*, 15 f). The book was certainly known to Clement of Rome, Irenaeus, Tertullian, Clement of Alexandria and Hippolytus. The Muratorian Fragment states the work to have been "composed by the friends of Solomon in his honor" (ll. 69-71). Zahn (*Gesch. Kan.*, II, 101, following a suggestion of Tregelles) prefers to read "composed by Philo in Solomon's honor"—an easy change in the Gr (*philōnos* for *philōn*). Origen (*Con. Cel.*, v. 29) calls it "the work entitled Wisdom of Solomon," so intimating doubt as to the authorship.

**XII. Text and Versions.**—The text in B, pointed with collations in Swete's *OT in Gr*, is on the whole the best, though both N and C (which is incomplete) have good texts, A being fairly trustworthy. The text is found also in fair preservation in many cursives.

The Vulg is identical with, but has slight variations from, the Old Lat. Lagarde (*Mittheilungen*, 243-86) gives the Lat VS of Sir and

**1. Latin** Wisd found in Cod. Amiaut. This last is a literal rendering from the Greek.

The Syr (Pesh) VS found in the *London Polyglot* and in Lagarde (*Lib. Apoc Syr*) was made immediately from the Gr, but apparently from the text in A, or in one like it.

**2. Syriac** apparently from the text in A, or in one like it.

**LITERATURE.**—Besides the works cited in the course of the foregoing article and the general works (comms., etc) on the Apoc mentioned under ΑΠΟΚΡΥΦΑ (q.v.), the following are to be noted:

(1) *Comms.*: Bauermeister, *Comm. in Sap. Sol. libr.*, 1828; Grimm, *Komm. über das Buch der Weisheit*, 1857; also his excellent comm. in the *Kurzgefasstes exegetisches Handbuch*, series 1860; J. H. Schmid, *Das Buch der*

*Weisheit: Uebersetzt und erklärt*, 1857; Gutherlet, *Das Buch der Weisheit*, 1874; W. J. Deane, *The Book of Wisd*, Gr Vulg and AV with "Comm." (1881, full and fairly scholarly); *Speaker's Apoc* (Farrar) is interesting and often helpful; Siegfried's "Intro" and "Comm." in Kautzsch's *Die Apoc* is slight, but also often helpful; *The Wisd of Solomon* by J. A. E. Gregg (RV with "Intro" and "Comm.") *Cambridge Bible* is brief and popular, but trustworthy; A. T. S. Goodrick, *The Book of Wisdom*, 1913 (admirable); S. Holmes (in the *Oxford Apoc*, with Intro and Comm.).

(2) Of the dict. arts., that in *EB* (by C. H. Toy) is perhaps the best; that in *HDB* (Siegfried) is fair but defective.

(3) In addition to the works by Gröförer and Dähne discussing the philosophy of the book, the following works may be mentioned: Bruch, *Weisheits-Lehre der Hebräer*, 1851 (322-78); Zeller, *Die Philosophie der Griechen* (1881), III, pt. 2, 271-74, 4th ed, 272-96; Kübel, "Die ethischen Grundanschauungen der Weisheit Salomos," in *Theologische Studien und Kritiken*, 1865, 690-722; Menzel, *Der griechische Einfluss auf Prediger und Weisheit Salomos*, 1889, 39-70; Bois, *Essai sur les origines de la philosophie judéo-alexandrine*, 1890, 211-309, 337-412. The work by Drummond, often quoted, has been carefully done and is interestingly written (*Philo Judaicus*, 1888, 2 vols; see I, 177-229).

For detailed bibliography see Schürer, *GJV*, 1909, III, 508 ff; *HJP*, 1886, II, 3, pp. 236 f, is necessarily very defective.

T. WITTON DAVIES

WISE, wīz, MAN. See WISDOM.

**WISE-MEN, wīz'men:** In addition to the uses of "wise" specified in the art. WISDOM, the adj. is employed occasionally as the technical description of men who are adepts in magic, divination, etc (e.g. in Gen 41 8; Ex 7 11; Est 1 13; Dnl 2 27; 5 15). Naturally, however, in the ancient world the boundary between genuine knowledge and astrology, etc, was exceedingly vague, and it was never denied that real knowledge could be gained along lines that we know to be futile. So the initiation of Moses into all the wisdom of the Egyptians (Acts 7 22) or of Daniel into all the learning of the Chaldaeans (Dnl 1 4) met with no disapproval. These great men could be trusted to avoid the moral and religious pitfalls of such pursuits. For the ordinary Israelites, however, the uncompromising prohibition of idolatry closed the door definitely to all studies of this kind. See ASTROLOGY; DIVINATION, etc. And for the Wise-men of Mt 2 see MAGI.

BURTON SCOTT EASTON

**WISH, wish:** The word appears both as a substantive and as a vb. in the OT, having a variety of meanings: (1) The subst., פֶּה, *peh*, means "mouth" and also "speech." In this form it occurs in Job 33 6 m: "Behold, I am according to thy wish in God's stead." Elihu here refers to Job's expressed desire for an umpire (9 33), and one who would maintain his right with God (16 21). (2) The verb: (a) אָרַב, *hāphēç*, "willing," or "desirous" (Ps 40 14 AV); (b) שָׁאַל, *shā'al*, "to ask," "petition," "supplicate" (Job 31 30 AV); (c) another variation of meaning is found in Ps 73 7 where מִשְׁכִּיתִי, *maskūth*, "to imagine," is tr<sup>d</sup> "wish": "They have more than heart could wish"; (d) εὐχόμεναι, *eúchomai*, "to solicit," "to implore" (Rom 9 3).

ARTHUR WALWYN EVANS

**WIST, wist, WITTY, wit'i, WOT, wot:** The vb. "to wit" in AV is interchangeable with "to know," and is conjugated with a present "wot," and a past "wist." This inflection is derived from more complicated forms in the older Eng., and in post-Elizabethan times has become quite obsolete. (But of the roots in "wisdom," "witness.") "Wit," then, is simply "knowledge," and "witty" is "having knowledge," although the noun and the adj. have become narrowly specialized in modern Eng. (cf the similar evolution of "knowing," in its use as an adj.). Even in Elizabethan Eng., however, the indicative of "to wit" was becoming displaced by



“know,” and “wot” and “wist” together occur only 24 t in AV (not at all in Apoc). ERV has retained all the NT examples, but in the OT has altered about half the occurrences to “know,” but has followed no discoverable rule in so doing (“wot” retained only in Josh 2 5). ARV has changed to “know” throughout (OT and NT). The inf. “to wit” is still in use (chiefly in legal formulas) before an apposition, and AV has introduced it rather frequently to clarify a construction (Josh 17 1; 1 K 2 32, etc), and RV has usually retained it (omitted in Josh 17 1; 2 Ch 4 12). In the other uses of this inf. (Gen 24 21; Ex 2 4) it is replaced by “to know,” while the very obsolete expression in 2 Cor 8 1, AV “We do you to wit” (i.e. “We cause you to know”; see Do), has become in RV “We make known unto you.”

The noun “wit” is found in Ps 107 27, “at their wits [AV “wit’s”] end,” for חִכְמָה, *hokhmāh*, “wisdom,” “technical skill”; cf RVm “All their wisdom is swallowed up.” The meaning is “their skilled seamanship cannot cope with the danger” (the phrase is very commonly misapplied). “Wit” occurs also 1 Esd 4 26 (*διάνοια*, *diánoia*, “mind”); 2 Esd 5 9 (*sensus*, here “intelligence”); Sir 31 20 (*ψυχή*, *psuchē*, “soul,” with the force of “reason”).

Witty is found in AV, RVm Prov 8 12, “witty inventions” (חֵכְמָה, *m’zummāh*, “discretion” [so RV]; if “and” is not read in this verse, translate “discrete knowledge”). In Jth 11 23 occurs “witty in thy words” (*ἀγαθός*, *agathós*, “good,” here probably = “thou hast spoken sound sense”). Wisd 8 19 AV has “a witty child,” RV “a child of parts,” in “goodly” (*εὐφύης*, *euphūēs*, “well grown,” “of a good disposition,” “clever”). “Wittingly” occurs in Gen 48 14 (חָכְמָה, *sākhāl*, “act intelligently”).

BURTON SCOTT EASTON

#### WITCH, wīch, WITCHCRAFT, wīch’kraf’t:

1. The Words, Their Meaning and Use
2. Biblical Usage
3. Common Elements in Witchcraft and Ancient Oriental Magic
4. Rise, Spread and Persecution of Witchcraft

#### LITERATURE

The word “witch” seems to denote etymologically “one that knows.” It is historically both masculine and feminine; indeed the AS

**1. Meaning** form *wicca*, to which the Eng. word is and Use of to be traced, is masc. alone. “Wiz-the Words ard” is given as masc. for witch, but it has in reality no connection with it.

Wright (*English Dialect Dict.*, VII, 521) says he never heard an uneducated person speak of wizard. When this word is used by the people it denotes, he says, a person who undoes the work of a witch. Shakespeare often uses “witch” of a male (cf *Cymbeline*, I, 6, l. 166: “He is . . . a witch”). In Wyclif’s tr of Acts 8 9 Simon Magus is called “a witch” (“wicche”). Since the 13th cent. the word “witch” has come more and more to denote a woman who has formed a compact with the devil or with evil spirits, by whose aid she is able to cause all sorts of injury to living beings and to things. The term “witchcraft” means in modern Eng. the arts and practices of such women.

Since the ideas we attach to “witch” and “witchcraft” were unknown in Bible times, the words have no right place in our Eng. Bible, and

**2. Biblical Usage** this has been recognized to some extent but not completely by the Revisers of 1884. The word “witch”

occurs twice in AV, viz. (1) in Ex 22 18, “Thou shalt not suffer a witch [RV “a sorceress”] to live”; (2) in Dt 18 10, “or a witch” (RV “or a sorcerer”). The Heb word is in both cases the participle of the vb. (חָשַׁף, *kishshēph*), denoting “to practice the

magical art.” See MAGIC, V, 2. In the first passage, however, the fem. ending (-āh) is attached, but this ending denotes also one of a class and (on the contrary) a collection of units; see Kautzsch, *Heb Gram.*<sup>28</sup>, § 122, s. t.

The phrase “the witch of Endor” occurs frequently in literature, and esp. in common parlance, but it is not found in the Eng. Bible. The expression has come from the heading and summary of the AV, both often so misleading. In 1 S 28, where alone the character is spoken of, EV translates the Heb *’ēsheth ba’ālah* *’ōbh* by “a woman that hath a familiar spirit.” A literal rendering would be “a woman who is mistress of an *’ōbh* or ghost,” i.e. one able to compel the departed spirit to return and to answer certain questions. This woman was therefore a necromancer, a species of diviner (see DIVINATION, IV; ENDOR, WITCH OF; FAMILIAR SPIRIT), and not what the term “witch” imports.

The word “witchcraft” occurs thrice in AV. In 1 S 15 23, “the sin of witchcraft” should be as in RVm, “the sin of divination,” the latter representing the Heb word חָשַׁף, *qeshem*, generally tr<sup>d</sup> “divination”; see DIVINATION, VII, 1.

The phrase “used witchcraft” (of Manasseh, 2 Ch 33 16) is properly rendered in RV “practised sorcery,” the Heb vb. (חָשַׁף, *kishshēph*) being that whence the participles in Ex 22 18 and Dt 18 10, tr<sup>d</sup> in AV “witch,” are derived (see above). The word tr<sup>d</sup> in AV “witchcraft” in Gal 5 20 (*φάρμακεια*, *pharmakeia*) is the ordinary Gr one for “sorcery,” and is so rendered in RV, though it means literally the act of administering drugs and then of giving magical potions. It naturally comes then to stand for the magician’s art, as in the present passage and also in Wisd 12 4; 18 13; and in the LXX of Isa 47 9, where it represents the Heb noun חָשַׁפִּים, *keshāphīm*, tr<sup>d</sup> “sorceries”; cf the Heb vb. חָשַׁף, *kishshēph*; see above.

The pl. “witchcrafts” (in AV and RV) stands for the Heb noun just noticed (*keshāphīm*) in 2 K 9 22; Mic 5 12; Nah 3 4, but in all three passages a proper rendering would be “sorceries” or “magical arts.” “Witchcrafts” is inaccurate and misleading.

The vb. “bewitch” occurs in Acts 8 9.11 AV (of Simon Magus bewitching the people) and in Gal 3 1 (“O foolish Galatians, who hath bewitched you?”). In the first context the Gr vb. is ἐκίστημι, *existēmi*, which is properly rendered by the Revisers “amazed”; in ver 13 the passive of the same vb. is tr<sup>d</sup> “He was amazed” (AV “He wondered”). In Gal 3 1, the vb. is βασκαίνω, *baskainō*, which is used of a blinding effect of the evil eye and has perhaps an occult reference, but it has nothing whatever to do with “witch” or “witchcraft.”

Though the conceptions conveyed by the Eng. word “witch” and its cognates were unknown to the

Hebrews of Bible times, yet the fundamental mental thought involved in such terms **3. Common Elements in Witchcraft** Hebrews and to other nations of antiquity (Babylonians, Egyptians, etc), **Oriental Magic** viz. that there exists a class of persons called by us magicians, sorcerers, etc, who have superhuman power over living creatures including man, and also over Nature and natural objects. This power is of two kinds: (1) cosmic, (2) personal. For an explanation see MAGIC, II. It is in Assy-Bab literature that we have the completest account of magical doctrine and practice. The words used in that literature for the male and female magician are *ashāpu* and *ashītu*, which correspond to the Heb *m’khashshēph* and *m’khashshēphāh* in Dt 18 10 and Ex 22 18 (see 2, above) and are cognate to חָשַׁף, *’ashshāph* (see Dnl 1 20; 2 2.10, etc), which means a magician (RV “enchanter”). Other Bab words are *kashshapu* and *kashshapu*, which in etymology and

in sense agree with the Heb terms *m'khashshēph* and *m'khashshēphāh* mentioned above. But neither in the Bab or Heb words is there the peculiar idea of a witch, viz. one who traffics with malicious spirits for malicious ends. Indeed the magician was a source of good (male and female) as conceived by the Babylonians, esp. the *ashipu* and *ashiptu*, to the state and to individuals, as well as of evil, and he was often therefore in the service of the state as the guide of its policy. And the same applies to the magician as the Hebrews regarded him, though the true teachers and leaders in Israel condemned magic and divination of every sort as being radically opposed to the religion of Jeh (Dt 18 10f). Of course, if a Bab magician used his art to the injury of others he was punished as other criminals, and in case of the death of the victim he was executed as a murderer. It is, however, noteworthy in its bearing on "witchcraft" that the female magician or sorceress played a larger part in ancient Babylonia than her male counterpart, and the same is true of the Greeks and other ancient people. This arose perhaps from the fact that in primitive times men spent their time in fighting and hunting; the cooking of the food and the healing of the sick, wounded, etc, by magical potions and otherwise, falling to the lot of the woman who stayed at home. In the early history of the Hebrews inspired women played a greater rôle than in later time; cf Miriam (Ex 15 20 f; Nu 12); Deborah (Jgs 5 12); Huldah (2 K 22 14 ff). Note also the אִשְׁשָׁה הַכְּהָמָה, 'ishshāh hākhāmāh, or "wise woman" of 2 S 14 2 ff; 20 16.

The first two sections of the CH are as follows: "1. If a man has laid a curse [*hispu* = כְּשָׁפִים, *k'shāphīm*] upon [another] man and it is not justified, he that laid the curse shall be put to death. 2. If a man has put a spell upon [another] man and it is not justified, he upon whom the spell is laid shall go to the holy river; into the holy river shall he plunge. If the holy river overcome him [and he is drowned], the man who put the spell upon him shall take possession of his house. If the holy river declares him innocent and he remains unharmed the man who laid the spell shall be put to death. He that plunged into the river shall take possession of the house of him who laid the spell upon him." Not a word is said here of a female that weaves a spell, but probably the word "man" in the Bab is to be taken as including male and female (so Canon C. H. W. Johns in a private letter, dated December 22, 1912).

In the early and esp. in the mediaeval church, the conception of the devil occupied a very important place, and human beings were thought to be under his dominion until he was

**4. Rise, Spread and Persecution of Witchcraft**  
exorcised in baptism. It is to this belief that we owe the rise and spread of infant baptism. The unbaptized were thought to be devil-possessed. The belief in the existence of women magicians had come down from hoary antiquity. It was but a short step to ascribe the evil those women wrought to the devil and his hosts. Then it was natural to think that the devil would not grant such extraordinary powers without some *quid pro quo*; hence the witch (or wizard) was supposed to have sold her (or his) soul to the devil, a proceeding that would delight the heart of the great enemy of good always on the alert to hinder the salvation of men; cf the Faust legend. For the conditions believed to be imposed by the devil upon all who would be in league with him see A. Lehmann, *Aberglaube und Zauberei*<sup>2</sup> (1908), 110 ff.

This idea of a covenant with the devil is wholly absent from the early heathen conception of magic; nor do we in the latter read of meetings at night between the magicians and the demons with whom they dealt, such as took place on the Witches' Sabbath. The witches were believed to have sexual commerce with devils and to be capable only of

inflicting evil, both thoughts alien to oriental and therefore to Bib. magic.

The history and persecution and execution of women, generally ignorant and innocent, supposed to have been guilty of witchcraft, do not fall within the scope of this article, but may be perused in innumerable works: see "Literature" below. In Europe alone, not to mention America (Salem, etc), Sprenger says that over nine million suspected witches were put to death on the flimsiest evidence; even if this estimate be too high the actual number must have been enormous. The present writer in his booklet, *The Survival of the Evangelical Faith* ("Essays for the Times," 1909), gives a brief account of the defence of the reality of witch power by nearly all the Christian theologians of the 17th cent. and by most of those living in the early 18th cent. (see pp. 23 ff). See also MAGIC, and *Expos T*, IX, 157 ff.

LITERATURE.—In addition to the literature cited under arts. DIVINATION and MAGIC (q.v.), the following works may be mentioned (the books on witchcraft proper are simply innumerable): Reginald Scot, *The Discovery of Witchcraft* (aimed at preventing the persecution of witches, 1584; republished London, 1886); reply to the last work by James I of England: *Daemonologie*, 1597; Casaubon, *On Credulity and Incredulity . . . A Treatise Proving Spirits, Witches and Supernatural Operations*, 1668; Joseph Glanvill, *Saducismus Triumphatus: Full and Plain Evidences concerning Witches and Apparitions* (the last two books are by theologians who class with "atheists"—a vague word in those times for unbelief—all such as doubt the power of witches and deny the power of devils upon human life). For the history of witchcraft and its persecutions see Howard Williams, *The Superstitions of Witchcraft*, 1865, and (brief but interesting and compact) Charles Mackay, *Memoirs of Extraordinary Popular Delusions* (2 vols, 1851, 101-91). See also Sir W. Scott, *Demonology and Witchcraft*, 1830; W. R. Halliday, *Gr Divination: A Study of Its Methods and Principles*, London, Macmillan (important); and art. by the present writer in *Expos*, January, 1914, on "The Words Witch and Witchcraft in History and in Literature." For a full account of the witch craze and persecution at Salem, near Boston, U.S.A., see *The Wonders of the Invisible World* by Cotton Mather, D.D., with a further account by Increase Mather, D.D., and cf *Demon Possession* by J. L. Nevins, 303-10.

T. WITTON DAVIES  
**WITHERED**, with'erd (בָּלַד, *wābhēl*, "to fade away," "to be dried up"): (1) Used figuratively to express leanness of soul, spiritual impotence, a low condition of spiritual life, a lack of moral nourishment: "My heart is smitten like grass, and withereth" (Ps 102 4). The contrasting figure emphasizes this idea: "All my fountains are in thee" (87 7). Also Ps 1 3, where the freshness and beauty of the righteous man's life are thus described: "And he shall be like a tree planted by the streams of water, . . . whose leaf also doth not wither." In the NT *ξηραίνω*, *xērainō*, "to wither," is used to carry out the same idea of moral decay, or malnutrition of soul (Mt 13 6; 21 19). (2) "Wither" also had a physiological meaning, expressing both in the OT and in the NT the idea of bodily impotence, esp., though not exclusively, of the limbs. Jeroboam was struck suddenly with paralysis of the arm, which is said to have "dried up" (1 K 13 4-6); "probably due to sudden hemorrhage affecting some part of the brain, which may under certain circumstances be only temporary" (*HDB*, 1-vol, 599). "Their skin cleaveth to their bones; it is withered" (Lam 4 8).

In the NT (Mt 12 10; Mk 3 1; Lk 6 6) "withered hand" was probably our modern "infantile paralysis," which may leave one or more limbs shrunken and powerless without detriment to the general health. ARTHUR WALWYN EVANS

**WITNES**, withs, withs, **WITHS**, withs, **GREEN** (יָתֵרִים לַחִים, *ythārīm laḥīm*, m "new bowstrings," AVm "new [moist] cords" [Jgs 16 7]; LXX νεῦρά ὑγρά, *neurá hugrá*): The material with which Samson was bound by Delilah (ver 8) was probably some moist "gut" such as was used for bowstrings. Cf מֵיתָרִים, *mēthārīm*, "bowstrings" (Ps 21 12; יֵתֵר, *yether*, Job 30 11; Ps 11 2); *laḥīm*, tr<sup>d</sup> "green," means "fresh," "sappy" or "moist."

**WITNESS**, wit'nes (nouns וֵדוּת, 'ēdh, and עֵדוּת, 'ēdhāh, and vb. עָדָה, 'ānāh; μάρτυς, mártus, with all derivative words and their compounds): The word "witness" is used of inanimate things, e.g. the heap of stones testifying to the covenant between Jacob and Laban (Gen 31 44-54), and the Song of Moses (Dt 31 19, 21). The main use of the word is forensic, and from this use all other applications are naturally derived. Important legal agreements required the attestation of witnesses, as in the case of the purchase of property, or a betrothal (Ruth 4 1-11, where we are told that the ancient form of attestation was by a man drawing off his shoe and giving it to his neighbor).

The Mosaic Law insisted on the absolute necessity of witnesses in all cases which came before a judge, esp. in criminal cases. Not only in criminal cases, but in all cases, it was necessary to have at least two witnesses to make good an accusation against a person (Dt 17 6; 19 15; cf Nu 35 30; Mt 18 16; Jn 8 17; 2 Cor 13 1; 1 Tim 5 19). According to the Talm (*P'sāhīm* 113b), if in a case of immorality only one witness came forward to accuse anyone, it was regarded as sinful on the part of that witness.

On the other hand, anyone who, being present at the adjuration (Lev 5 1 RV), refused to come forward as a witness when he had testimony to bear, was considered to have sinned (Prov 29 24). Among those not qualified to be witnesses were the near relations of the accuser or the accused, friends and enemies, gamesters, usurers, tax-gatherers, heathen, slaves, women and those not of age (*Sanhedhrin* 3 3, 4; *Rō'sh Ha-shānāh* 1 7; *Bābhā' Kammā'* 88a; cf *Ant.* IV, viii, 15). No one could be a witness who had been paid to render this service (*B'khōrōth* 4 6). In cases of capital punishment there was an elaborate system of warning and cautioning witnesses. Each witness had to be heard separately (*Sanhedhrin* 5; cf 3 5). If they contradicted one another on important points their witness was invalidated (*Sanhedhrin* 5).

No oath was required from witnesses. The meaning of Lev 5 1 was not that witnesses had to take an oath, as some think; it describes the solemn adjuration of the judge to all those with knowledge of the case to come forward as witnesses (see OATH). When a criminal was to be put to death, the witnesses against him were to take the foremost share in bringing about his death (Dt 17 7; cf Acts 7 58), in order to prove their own belief in their testimony. In the case of a person condemned to be stoned, all the witnesses had to lay their hands on the head of the condemned (Lev 24 14). "False witnessing" was prohibited in the Decalogue (Ex 20 16); against it the *lex talionis* was enforced, i.e. it was done to the witness as he meant to do to the accused (Dt 19 16-21). The Sadducees held that only when the falsely accused had been executed, the false witnesses should be put to death; the Pharisees, that false witnesses were liable to be executed the moment the death sentence had been passed on the falsely accused (*Makkōth* 1 7). In spite of prohibitions, false witnessing was a very common crime among the people (Ps 27 12; 35 11; Prov 6 19; 12 17; 14 5; 19 5; 24 28; Mt 26 60; Acts 6 13).

In Acts 22 20; Rev 2 13; 17 6 the word *mártus*, "witness," seems to be beginning to acquire the meaning of "martyr," as in AV, although RV translates "witness" in the first two passages, retaining "martyr" only in the third with "witness" in the m. For "Tabernacle of Witness" see TABERNACLE. PAUL LEVERTOFF

**WITNESS OF THE SPIRIT:** This phrase arises from the words of Rom 8 16: "The Spirit himself beareth witness with our spirit, that we are

children of God." With this may be grouped, as illustrative, 1 Jn 5 10: "He that believeth on the Son of God hath the witness in him." In interpreting, we may approach the former passage through the latter. To the man who "believeth on the Son of God," so as to *prove Him by reliance*, He becomes self-evidential in experience, verifying Himself to the believer as the Divine response to his whole spiritual need. Thus believed on *as the Son*, He awakens in the soul which He embraces the *filial* attitude toward God, the cry, "Abba, Father." On the other side the Spirit, both in the written Word (e.g. Jn 1 12) and in His secret converse with the believer in the life of faith, assures him of the paternal love toward him, as toward a "dear child," (Eph 5 1) of the Father of his Lord. There is thus a concurrent "witnessing." The believer's spirit says, "Thou art my Father"; the Spirit says to the believer's spirit, "Thou art His child." We may compare Rom 5 5: "The love of God hath been shed abroad in our hearts through the Holy Spirit." HANDLEY DUNELM

**WITTY.** See WIST, WITTY, WOT.

**WIZARD,** wiz'ard. See ASTROLOGY, 1; DIVINATION; FAMILIAR SPIRIT; MAGIC; WITCH, WITCHCRAFT.

**WOLF,** wólf ([1] לְבוֹיָא, *l'bh* [Gen 49 27; Isa 11 6; 65 25; Jer 5 6; Ezk 22 27; Hab 1 8; Zeph 3 3; also as proper name, Zeeb, prince of Midian, Jgs 7 25; 8 3; Ps 83 11]; cf Arab.

ذئب, *dh'ib*, colloquial ذئب, *dh'ib*, or ذئب, *dh'ib*; [2] λύκος, *lúkos* [Mt 7 15; 10 16; Lk 10 3;



Wolf (*Canis lupus*).

Jn 10 12; Acts 20 29; Ecclus 13 17; cf 2 Esd 5 18, *lupus*); [3] לְבוֹיָא, *lyim*, RV "wolves" [Isa 13 22; 34 14; Jer 50 39]]:

While the wolf is surpassed in size by some dogs, it is the fiercest member of the dog family (*Canidae*), which includes among others the jackal and the fox. Dogs, wolves and jackals are closely allied and will breed together. There is no doubt that the first dogs were domesticated wolves. While there are local varieties which some consider to be distinct species, it is allowable to regard all the wolves of both North America, Europe, and Northern Asia (except the American coyote) as members of one species, *Canis lupus*. The wolf of Syria and Pal is large, light colored, and does not seem to hunt in packs. Like other wolves it is nocturnal. In Pal it is the special enemy of the sheep and goats. This fact comes out in two of the seven passages cited from the OT, in all from the NT, and in the two from Apoc. In Gen 49 27 Benjamin is likened to a ravening wolf. In Ezk 22 27, and in the similar Zeph 3 3, the elders of Jerus are compared to wolves. In Jer 5 6 it is a wolf that shall destroy

the people of Jerus, and in Hab 1 8 the horses of the Chaldaeans "are swifter than leopards, and are more fierce than the evening wolves." Babylon and Edom (Isa 13 22; 34 14; Jer 50 39) are to be the haunts of 'iyim (RV "wolves") and other wild creatures.

The name of Zeeb, prince of Midian (Jgs 7 25; 8 3), has its parallel in the Arab. *Dib* or *Dhib*, which is a common name today. Such animal names are frequently given to ward off the evil eye. See also TOTEMISM.

ALFRED ELY DAY

WOMAN, wōm'an (אִשָּׁה, 'ishshāh, "a woman" [fem. of אִישׁ, 'ish, "a man"]; γυνή, gunē, "a woman," "wife"):

- I. IN THE CREATIVE PLAN
- II. IN OT TIMES
  - 1. Prominence of Women
  - 2. Social Equality
  - 3. Marriage Laws
  - 4. Inheritance
  - 5. Domestic Duties
  - 6. Dress and Ornaments
  - 7. Religious Devotion and Service
    - (1) In Idolatry and False Religion
    - (2) In Spiritual Religion
- III. INTER-TESTAMENT ERA
- IV. IN NT TIMES
  - 1. Mary and Elisabeth
  - 2. Jesus and Women
  - 3. In the Early Church
  - 4. Official Service
  - 5. Widows
  - 6. Deaconesses
- V. LATER TIMES
  - 1. Changes in Character and Condition
  - 2. Notable Examples of Christian Womanhood
  - 3. Woman in the 20th Century

The generic term "man" includes woman. In the narrative of the creation (Gen 1 26,27) Adam is a collective term for mankind. It may signify a human being, male or female, or humanity entire. "God said, Let us make man . . . and let them" (ver 26), the latter word "them" defining "man" in the former clause. So in ver 27, "In the image of God created he him; male and female created he them," "them" being synonymous with "him" (see also ADAM; ANTHROPOLOGY).

**I. In the Creative Plan.**—Whatever interpretation the latest scholarship may give to the story of woman's formation from the rib of man (Gen 2 21-24), the passage indicates, most profoundly, the inseparable unity and fellowship of her life with his. Far more than being a mere assistant, "helper" (אֵזֶר, 'ezer, "help," "helper," Gen 2 18), she is man's complement, essential to the perfection of his being. Without her he is not *man* in the generic fulness of that term. Priority of creation may indicate headship, but not, as theologians have so uniformly affirmed, superiority. Dependence indicates difference of function, not inferiority. Human values are estimated in terms of the mental and spiritual. Man and woman are endowed for equality, and are mutually interdependent. Physical strength and prowess cannot be rated in the same category with moral courage and the capacity to endure ill-treatment, sorrow and pain; and in these latter qualities woman has always proved herself the superior. Man's historic treatment of woman, due to his conceit, ignorance or moral perversion, has taken her inferiority for granted, and has thus necessitated it by her enslavement and degradation. The narrative of the Fall (Gen 3) ascribes to woman supremacy of influence, for through her stronger personality man was led to disobedience of God's command. Her penalty for such ill-fated leadership was that her husband should "rule over" her (Gen 3 16), not because of any inherent superiority on his part, but because of her loss of prestige and power through sin. In that act she forfeited the respect and confidence which entitled her to equal-

ity of influence in family affairs. Her recovery from the curse of subjection was to come through the afflictive suffering of maternity, for, as St. Paul puts it, "she shall be saved [from the penalty of her transgression] through her child-bearing" (1 Tim 2 15).

Sin, both in man and woman, has been universally the cause of woman's degradation. All history must be interpreted in the light of man's consequent mistaken estimate of her endowments, worth and rightful place. The ancient Hebrews never entirely lost the light of their original revelation, and, more than any other oriental race, held woman in high esteem, honor and affection. Christianity completed the work of her restoration to equality of opportunity and place. Wherever its teachings and spirit prevail, she is made the loved companion, confidante and adviser of her husband.

**II. In OT Times.**—Under the Heb system the position of woman was in marked contrast with her status in surrounding heathen nations. Her liberties were greater, her employments more varied and important, her social standing more respectful and commanding. The Divine law given on Sinai (Ex 20 12) required children to honor the mother equally with the father. A similar esteem was accorded her in patriarchal times. Sarah held a position of favor and authority in Abraham's household. Rebekah was not less influential than Isaac, and was evidently the stronger personality. The "beautiful" Rachel (Gen 29 17) won from Jacob a love that accepted her as an equal in the companionship and counsels of family life. Many Heb women rose to eminence and national leadership. Miriam and Deborah were each a prophetess and a poetess. The former led bands of women in triumphant song and procession, celebrating the overthrow of enemies (Ex 15 20); the latter, through her dominating personality and prophetic power, became the virtual judge of the nation and led armies to victory. Her military general, Barak, refused to advance against Siserā without her presence and commanding influence (Jgs 4 8). Her ode of victory indicates the intellectual endowment and culture of her sex in that unsettled and formative era (Jgs 5). No person in Israel surpassed Hannah, the mother of Samuel, in intelligence, beauty and fervor of religious devotion. Her spiritual exaltation and poetic gift found expression in one of the choicest specimens of early Heb lyric poetry (1 S 2 1-10). Other women eminent as prophetesses were: Huldah, whose counsel was sought by high priest and king (2 Ch 34 22; of 2 K 22 14); Noadiah (Neh 6 14); Anna (Lk 2 36). The power to which woman could attain in Israel is illustrated in the career of the wicked, merciless, murderous, idolatrous Jezebel, self-styled prophetess (Rēv 2 20). Evidence of woman's eminence in the kingdoms of Judah and Israel is seen in the influence she exercised as queen mother (1 K 15 13) and queen (2 K 8 18); in the beautiful honor shown by King Solomon to his mother, Bath-sheba (1 K 2 19); in the filial devotion of the prophet Elisha (1 K 19 20); in the constant mention of the mother's name in the biographies of successive kings, making it evident that she was considered the important and determining factor in the life of her royal sons. Her teaching and authority were sufficiently eminent to find recognition in the proverbs of the nation: "the law of thy mother" (Prov 1 8; 6 20) was not to be forsaken, while contempt for the same merited the curse of God (Prov 19 26; 20 20; 30 11,17).

Additional evidence of woman's social equality comes from the fact that men and women feasted together without restriction. Women shared in the sacred meals and great annual feasts (Dt 16 11,14); in wedding festivities (Jn 2 1-3); in the fellowship of the family meal (12 3). They could appear, as Sarah did in the court of Egypt, unveiled (Gen 12 11,14). Re-

**2. Social Equality**

bekah (Gen 24 16; cf ver 65), Rachel (29 11), Hannah (1 S 1 13) appeared in public and before suitors with uncovered faces. The secluding veil was introduced into Mohammedan and other oriental lauds through the influence of the Koran. The custom was non-Jewish in origin, and the monuments make it evident that it did not prevail, in early times, in Assyria and Egypt. Even Greece and Rome, at the time of their supreme culture, fell far below the Heb conception of woman's preëminent worth. The greatest Hellenic philosophers declared that it would radically disorganize the state for wives to claim equality with their husbands. Aristotle considered women inferior beings, intermediate between freemen and slaves. Socrates and Demosthenes held them in like depreciation. Plato advocated community of wives. Substantially the same views prevailed in Rome. Distinguished men, like Metellus and Cato, advocated marriage only as a public duty. More honor was shown the courtesan than the wife. Chastity and modesty, the choice inheritance of Heb womanhood, were foreign to the Gr conception of morality, and disappeared from Rome when Gr culture and frivolity entered. The Greeks made the shameless Phryne the model of the goddess Aphrodite, and lifted their hands to public prostitutes when they prayed in their temples. Under pagan culture and heathen darkness woman was universally subject to inferior and degrading conditions. Every decline in her status in the Heb commonwealth was due to the incursion of foreign influence. The lapses of Heb morality, esp. in the court of Solomon and of subsequent kings, occurred through the borrowing of idolatrous and heathen customs from surrounding nations (1 K 11 1-8).

The Bible gives no sanction to dual or plural marriages. The narrative in Gen 2 18-24 indicates that monogamy was the Divine

### 3. Marriage ideal for man. The moral decline of Laws

the generations antedating the Flood seems to have been due, chiefly, to the growing disregard of the sanctity of marriage. Lamech's taking of two wives (Gen 4 19) is the first recorded infraction of the Divine ideal. By Noah's time polygamy had degenerated into promiscuous inter-racial marriages of the most incestuous and illicit kind (Gen 6 1-4; see SONS OF GOD). The subsequent record ascribes marital infidelity and corruption to sin, and affirms that the destruction of the race by the Flood and the overthrow of Sodom and Gomorrah were God's specific judgment on man's immorality. The dual marriages of the Patriarchs were due, chiefly, to the desire for children, and are not to be traced to Divine consent or approval. The laws of Moses regarding chastity protected the sanctity of marriage (see MARRIAGE), and indicated a higher regard for woman than prevailed in gentile or other Sem races (Lev 18 6-20). They sought to safeguard her from the sensual abominations prevalent among the Egyptians and Canaanites (Lev 18). Kings were forbidden to "multiply wives" (Dt 17 17). Concubinage in Israel was an importation from heathenism.

Divorce was originally intended to protect the sanctity of wedlock by outlawing the offender and his moral offence. Its free extension to include any marital infelicity met the stern rebuke of Jesus, who declared that at the best it was a concession to human infirmity and hardness of heart, and should be granted only in case of adultery (Mt 5 32). See DIVORCE.

Heb women were granted a freedom in choosing a husband not known elsewhere in the East (Gen 24 58). Jewish tradition declares that a girl over 12½ years of age had the right to give herself in marriage. Vows made by a daughter, while under age, could be annulled by the father (Nu 30 3-5) or by the husband (vs 6-16). Whenever civil law made a concession to the customs of surrounding nations, as in granting the father power to sell a daughter into bondage, it sought to surround her with all possible protection (Dt 22 16 ff).

The Mosaic Law prescribed that the father's estate, in case there were no sons, should pass to the daughters (Nu 27 1-8). They

### 4. Inheritance

were not permitted, however, to alienate the family inheritance by marrying outside their own tribe (36 6-9). Such alien marriages were permissible only when the husband took the wife's family name (Neh 7 63). Unmarried daughters, not provided for in the

father's will, were to be cared for by the eldest son (Gen 31 14,15). The bride's dowry, at marriage, was intended as a substitute for her share in the family estate. In rabbinical law, a century or more before Christ, it took the form of a settlement upon the wife and was considered obligatory. Provision for woman under the ancient Mosaic Law was not inferior to her status under Eng. law regarding landed estates.

Among the Hebrews, woman administered the affairs of the home with a liberty and leadership unknown to other oriental peoples.

### 5. Domestic Duties

Her domestic duties were more independent, varied and honorable. She was not the slave or menial of her husband. Her outdoor occupations were congenial, healthful, extensive. She often tended the flocks (Gen 29 6; Ex 2 16); spun the wool, and made the clothing of the family (Ex 35 26; Prov 31 19; 1 S 2 19); contributed by her weaving and needlework to its income and support (Prov 31 14,24), and to charity (Acts 9 39). Women ground the grain (Mt 24 41); prepared the meals (Gen 18 6; 2 S 13 8; Jn 12 2); invited and received guests (Jgs 4 18; 1 S 25 18 ff; 2 K 4 8-10); drew water for household use (1 S 9 11; Jn 4 7), for guests and even for their camels (Gen 24 15-20). Heb women enjoyed a freedom that corresponds favorably with the larger liberties granted them in the Christian era.

That women were fond of decorations and display in ancient as in modern times is clear from the reproof administered by the prophet for their

### 6. Dress and Ornaments

haughtiness and excessive ornamentation (Isa 3 16). He bids them "remove [the] veil, strip off the train," that they may be better able to "grind meal" and attend to the other womanly duties of the home (47 2). These prophetic reproofs do not necessarily indicate general conditions, but exceptional tendencies to extravagance and excess. The ordinary dress of women was modest and simple, consisting of loose flowing robes, similar to those worn by men, and still in vogue among Orientals, chiefly the mantle, shawl and veil (Ruth 3 15; Isa 3 22,23). The veil, however, was not worn for seclusion, as among the Moslems. The extensive wardrobe and jewelry of Heb women is suggested by the catalogue given in Isa 3 18-24: anklets, cauls, crescents, pendants, bracelets, mufflers, headties, ankle chains, sashes, perfume-boxes, amulets, rings, nose-jewels, festival robes, mantles, shawls, satchels, hand-mirrors, fine linen, turbans, veils. The elaborateness of this ornamentation throws light on the apostle Peter's counsel to Christian women not to make their adornment external, e.g. the braiding of the hair, the wearing of jewels of gold, the putting on of showy apparel, but rather the apparel of a meek and quiet spirit (1 Pet 3 3,4).

The reflections cast upon woman for her leadership in the first transgression (Gen 3 6,13,16; 2 Cor 11 3; 1 Tim 2 14) do not indicate her

### 7. Religious and Devotion

rightful and subsequent place in the religious life of mankind. As wife, and Service mother, sister, she has been preëminently devout and spiritual. History records, however, sad and striking exceptions to this rule.

(1) Often woman's religious intensity found expression in idolatry and the gross cults of heathenism. That she everywhere participated freely in the religious rites and customs of her people is evident from the fact that women were often priestesses, and were often deified. The other Sem religions had female deities corresponding to the goddesses of Greece and Rome. In the cult of Ishtar of Babylon women were connected with the immoral rites of temple-worship. The women of heathen nations in the harem of Solomon (1 K 11 1) turned the heart of the wise king to unaccountable folly in the worship of the Sidonian goddess Ashtoreth, and of Chemosh and Molech, in turn the "abomination" of Moab and Ammon (11 5-8). The fatal spell of Maacah morally blighted the reigns of her husband,

son and grandson, until Asa the latter deposed her as queen and destroyed the obscene image of Asherah which she had set up (1 K 15 13). As "queen mother" (*g'bhrah*, "leader") she was equivalent to the Turkish *Sultana Valide*.

Baal-worship was introduced into Israel by Jezebel (1 K 16 31-32; 18 19; 2 K 9 22), and into Judah by her daughter Athaliah (2 Ch 22 3; 24 7). The prominence of women in idolatry and in the abominations of foreign religions is indicated in the writings of the prophets (Jer 7 18; Ezk 8 14). Their malign influence appeared in the sorceress and witch, condemned to death by the Mosaic Law (Ex 22 18); yet continuing through the nation's entire history. Even kings consulted them (1 S 28 7-14). The decline and overthrow of Judah and Israel must be attributed, in large measure, to the deleterious effect of wicked, worldly, idolatrous women upon their religious life.

(2) The bright side of Heb history is an inspiring contrast to this dark picture. Prior to the Christian era no more luminous names adorn the pages of history than those of the devout and eminent Heb women. Jochebed, the mother of Moses, left upon him a religious impress so vital and enduring as to safeguard him through youth and early manhood from the fascinating corruptions of Pharaoh's Egypt court (Ex 2 1-10; He 11 23-26). In Ruth, the converted Moabitess, the royal ancestress of David and of Jesus, we have an unrivaled example of filial piety, moral beauty and self-sacrificing religious devotion (Ruth 1 15-18). The prayers and piety of Hannah, taking effect in the spiritual power of her son Samuel, penetrated, purified and vitalized the religious life of the entire nation. Literature contains no finer tribute to the domestic virtues and spiritual qualities of woman than in the beautiful poem dedicated to his gifted mother by King Lemuel (Prov 31).

Women, as well as men, took upon themselves the self-renouncing vow of the Nazirite (Nu 6 2), and shared in offering sacrifices, as in the vow and sacrifice of Manoa's wife (Jgs 13 13,14); were granted theophanies, e.g. Hagar (Gen 16 7; 21 17), Sarah (18 9,10), Manoa's wife (Jgs 13 3-5,9); were even permitted to "minister" at the door of the sanctuary (Ex 38 8; 1 S 22 22); rendered conspicuous service in national religious songs and dances (Ex 15 20; Jgs 11 34; 1 S 18 6,7); in the great choirs and choruses and processions of the Temple (Ps 68 25; Ezr 2 65; Neh 7 67); in religious mourning (Jer 9 17-20; Mk 5 38). They shared equally with men in the great religious feasts, as is indicated by the law requiring their attendance (Dt 12 18).

**III. Inter-Testament Era.**—The women portrayed in the apocryphal literature of the Jews reveal all the varied characteristics of their sex so conspicuous in OT history: devout piety, ardent patriotism, poetic fervor, political intrigue, worldly ambition, and sometimes a strange combination of these contradictory moral qualities. Whether fictitious, or founded on fact, or historical, these portrayals are true to the feminine life of that era.

**Anna** is a beautiful example of wifely devotion. By her faith and hard toil she supported her husband Tobit, after the loss of his property and in his blindness, until sight and prosperity were both restored (Tob 1 9; 2 1-14).

**Edna**, wife of Raguel of Echatana and mother of Sarah, made her maternal love and piety conspicuous in the blessing bestowed on Tobias on the occasion of his marriage to her daughter, who had hitherto been cursed on the night of wedlock by the death of seven successive husbands (7; 10 12).

**Sarah**, innocent of their death, which had been compassed by the evil spirit Asmodeus, at last had the reward of her faith in the joys of a happy marriage (Tob 10 10; 14 13).

**Judith**, a rich young widow, celebrated in Heb lore as the savior of her nation, was devoutly and ardently patriotic. When Nebuchadnezzar sent his general Holofernes with an army of 132,000 men to subjugate the Jews, she felt called of God to be their deliverer. Visiting Holofernes, she so captivated him with her beauty and gifts that he made a banquet in her honor. While he was excessively drunk with the wine of his own bounty, she beheaded him in his tent. The Assyrians, paralyzed by the loss of their leader, easily fell a prey to the armies of Israel. Judith celebrates her triumph in a song, akin in its triumphant joy, patriotic fervor

and religious zeal, to the ancient songs of Miriam and Deborah (Jth 16 1-17).

**Susanna** typifies the ideal of womanly virtue. The daughter of righteous parents, well instructed in the sacred Law, the wife of a rich and honorable man, Joachim by name, she was richly blessed in position and person. Exceptionally modest, devout and withal very beautiful, she attracted the notice of two elders, who were also judges, and who took occasion frequently to visit Joachim's house. She spurned their advances and when falsely charged by them with the sin which she so successfully resisted, she escapes the judgment brought against her, by the subtle skill of Daniel. As a result, his fame and her innocence became widely known. See **SUSANNA**, HISTORY OF.

**Cleopatra**, full of inherited intrigue, is influential in the counsels of kings. She married successively for political power; murdered her eldest son Seleucus, by Demetrius, and at last dies by the poison which she intended for her younger son, Antiochus VIII. Her fatal influence is a striking example of the perverted use of woman's power (1 Macc 10 58; Jos, *Ant*, XIII, iv, 1; ix, 3).

**IV. In NT Times.**—A new era dawned for woman with the advent of Christianity. The

honor conferred upon **Mary**, as mother of Jesus, lifted her from her "low estate," made after-generations call her **Elisabeth** blessed (Lk 1 48), and carried its benediction to the women of all subsequent times. St. Luke's narrative of the Nativity (Lk 1, 2) has thrown about motherhood the halo of a new sanctity, given mankind a more exalted conception of woman's character and mission, and made the world's literature the vehicle of the same lofty reverence and regard. The two dispensations were brought together in the persons of **Elisabeth** and **Mary**: the former the mother of John the Baptist, the last of the old order of prophets; the latter the mother of the long-expected Messiah. Both are illustrious examples of Spirit-guided and Spirit-filled womanhood. The story of Mary's intellectual gifts, spiritual exaltation, purity and beauty of character, and her training of her Divine child, has been an inestimable contribution to woman's world-wide emancipation, and to the uplift and ennoblement of family life. To her poetic inspiration, spiritual fervor and exalted thankfulness as expectant mother of the Messiah, the church universal is indebted for its earliest and most majestic hymn, the *Magnificat*. In her the religious teachings, prophetic hopes, and noblest ideals of her race were epitomized. Jesus' reverence for woman and the new respect for her begotten by His teaching were well grounded, on their human side, in the qualities of His own mother. The fact that He Himself was born of woman has been cited to her praise in the ecumenical creeds of Christendom.

From the first, women were responsive to His teachings and devoted to His person. The sisters of

**Lazarus**, **Mary** and **Martha**, made their **2. Jesus** home at Bethany, His dearest earthly and Women refuge and resting-place. Women of

all ranks in society found in Him a benefactor and friend, before unknown in all the history of their sex. They accompanied Him, with the Twelve, in His preaching tours from city to city, some, like **Mary Magdalene**, grateful because healed of their moral infirmities (Lk 8 2); others, like **Joanna** the wife of Chuzas, and **Susanna**, to minister to His needs (8 3). Even those who were ostracized by society were recognized by Him, on the basis of immortal values, and restored to a womanhood of virtue and Christian devotion (Lk 7 37-50). Mothers had occasion to rejoice in His blessing their children (Mk 10 13-16); and in His raising their dead (Lk 7 12-15). Women followed Him on His last journey from Galilee to Jerus; ministered to Him on the way to Calvary (Mt 27 55,56); witnessed His crucifixion (Lk 23 49); accompanied His body to the sepulcher (Mt 27 61; Lk 23 55); prepared spices and ointments for His burial (Lk 23

56); were first at the tomb on the morning of His resurrection (Mt 28 1; Mk 16 1; Lk 24 1; Jn 20 1); and were the first to whom the risen Lord appeared (Mt 28 9; Mk 16 9; Jn 20 14). Among those thus faithful and favored were Mary Magdalene, Mary the mother of James and Josés, Salome (Mt 27 56), Joanna and other unnamed women (Lk 24 10). Women had the honor of being the first to announce the fact of the resurrection to the chosen disciples (Lk 24 9.10.22). They, including the mother of Jesus, were among the 120 who continued in prayer in the upper room and received the Pentecostal enduement (Acts 1 14); they were among the first Christian converts (8 12); suffered equally with men in the early persecutions of the church (9 2). The Jewish enemies of the new faith sought their aid and influence in the persecutions raised against Paul and Barnabas (13 50); while women of equal rank among the Greeks became ardent and intelligent believers (17 12). The fidelity of women to Jesus during His three years' ministry, and at the cross and sepulcher, typifies their spiritual devotion in the activities and enterprises of the church of the 20th century.

Women were prominent, from the first, in the activities of the early church. Their faith and prayers helped to make Pentecost

### 3. In the Early Church

possible (Acts 1 14). They were eminent, as in the case of Dorcas, in charity and good deeds (9 36); foremost in prayer, like Mary the mother of John, who assembled the disciples at her home to pray for Peter's deliverance (12 12). Priscilla is equally gifted with her husband as an expounder of "the way of God," and instructor of Apollos (18 26), and as Paul's "fellow-worker in Christ" (Rom 16 3). The daughters of Philip were prophetesses (Acts 21 8.9). The first convert in Europe was a woman, Lydia of Thyatira, whose hospitality made a home for Paul and a meeting-place for the infant church (16 14). Women, as truly as men, were recipients of the charismatic gifts of Christianity. The apostolic greetings in the Epp. give them a place of honor. The church at Rome seems to have been blessed with a goodly number of gifted and consecrated women, inasmuch as Paul in the closing salutations of his Epp. sends greetings to at least eight prominent in Christian activity: Phoebe, Prisca, Mary "who bestowed much labor on you," Tryphena and Tryphosa, Persis, Julia, and the sister of Nereus (Rom 16 1.3.6.12.15). To no woman did the great apostle feel himself more deeply indebted than to Lois and Eunice, grandmother and mother of Timothy, whose "faith unfeigned" and ceaseless instructions from the holy Scriptures (2 Tim 1 5; 3 14.15) gave him the most "beloved child" and assistant in his ministry. Their names have been conspicuous in Christian history for maternal love, spiritual devotion and fidelity in teaching the Word of God. See also CLAUDIA.

From the first, women held official positions of influence in the church. Phoebe (Rom 16 1) was

### 4. Official Service

evidently a deaconess, whom Paul terms "a servant of the church," "a helper of many" and of himself also. Those women who "labored with me in the gospel" (Phil 4 3) undoubtedly participated with him in preaching. Later on, the apostle used his authority to revoke this privilege, possibly because some women had been offensively forward in "usurping authority over the man" (1 Tim 2 12 AV). Even though he bases his argument for woman's keeping silence in public worship on Adam's priority of creation and her priority in transgression (2 13.14), modern scholarship unhesitatingly affirms that his prohibition was applicable only to the peculiar conditions of his own time.

Her culture, grace, scholarship, ability, religious devotion and spiritual endowment make it evident that she is often as truly called of God to public address and instruction as man. It is evident in the NT and in the writings of the Apostolic Fathers that women, through the agency of two ecclesiastical orders, were assigned official duties in the conduct and ministrations of the early church.

Their existence as a distinct order is indicated in 1 Tim 5 9.10, where Paul directs Timothy as to the conditions of their enrolment. No widow should be "enrolled" (*kataleýō*, *katalégo*, catalogued, "registered") under 60 years of age, or if more than once married. She must be "well reported of for good works"; a mother, having "brought up children"; hospitable, having "used hospitality to strangers"; Christlike in loving service, having washed the saints' feet." Chrysostom and Tertullian make mention of this order. It bound its members to the service of God for life, and assigned them ecclesiastical duties, e.g. the superintendence of the rest of the women, and the charge of the widows and orphans supported at public expense. Dean Alford (see *Comm.* in loc.) says they "were vowed to perpetual widowhood, clad in a *vestis vidualis* ['widow's garments'], and ordained by the laying on of hands. This institution was abolished by the eleventh Canon of the council of Laodicea."

Other special duties, mentioned by the Church Fathers, included prayer and fasting, visiting the sick, instruction of women, preparing them for baptism, assisting in the administration of this sacrament, and taking them to the communion. The spiritual nature of the office is indicated by its occupant being variously termed "the intercessor of the church," "the keeper of the door," at public service; "the altar of God." See WIDOWS.

Many of these duties were transferred, by the 3d cent., to the deaconesses, an order which in recent history has

been restored to its original importance and effectiveness. The women already referred to in Rom 16 1.6.12 were evidently of this order, the term *diakavō* *diakōnos*, being specifically applied to Phoebe, a deaconess of the church at Cenchreae. The women of 1 Tim 3 11, who were to serve "in like manner" as the "deacons" of ver 10, presumably held this office, as also the "aged women" of Tit 2 3 (= "presbyters" [fem.], *πρεσβύτεραι*, *presbūterai*, 1 Tim 5 2). Virgins as well as widows were elected to this office, and the age of eligibility was changed from 60 to 40 by the Council of Chalcedon. The order was suppressed in the Lat church in the 6th cent., and in the Gr church in the 12th, because of certain abuses that gradually became prevalent. Owing, however, to its exceptional importance and value it has been reinstated by nearly all branches of the modern church, the Methodists esp. emphasizing its spiritual efficiency. Special training schools and courses in education now prepare candidates for this office. Even as early as the Puritan Reformation in England the Congregationalists recognized this order of female workers in their discipline. The spiritual value of woman's ministry in the lay and official work of the church is evidenced by her leadership in all branches of ecclesiastical and missionary enterprise. This modern estimate of her capability and place revises the entire historic conception and attitude of mankind. See DEACONESS.

**V. Later Times.**—Tertullian mentions the modest garb worn by Christian women (*De Cult. Fem.*, ii.11) as indicating their conscio-

1. **Changes** in their new spiritual wealth and in **Character** worthiness. They no longer needed and **Condition** the former splendor of outward adornment, because clothed with the beauty and simplicity of Christlike character.

They exchanged the temples, theaters, and festivals of paganism for the home, labored with their hands, cared for their husbands and children, graciously dispensed Christian hospitality, nourished their spiritual life in the worship, service and sacraments of the church, and in loving ministries to the sick. Their modesty and simplicity were a rebuke to and reaction from the shameless extravagances and immoralities of heathenism. That they were among the most conspicuous examples of the transforming power of Christianity is manifest from the admiration and astonishment of the pagan Libanius who exclaimed, "What women these Christians have!"

The social and legal status of woman instantly improved when Christianity gained recognition in the Empire. Her property rights as wife were es-

established by law, and her husband made subject to accusation for marital infidelity. Her inferiority, subjection and servitude among all non-Jewish and non-Christian races, ancient and modern, are the severest possible arraignment of man's intelligence and virtue. Natural prudence should have discovered the necessity of a cultured and noble motherhood in order to a fine grade of manhood. Races that put blighting restrictions upon woman consign themselves to perpetual inferiority, impotence and final overthrow. The decline of Islam and the collapse of Turkey as a world-power are late striking illustrations of this fundamental truth.

Woman's activity in the early church came to its zenith in the 4th cent. The type of feminine character produced by Christianity in that era is indicated by such notable examples as Emelia and Macrina, the mother and sister

**2. Notable Examples of Christian Womanhood**

of Basil; Anthusa, Nonna, Monica, respectively the mothers of Chrysostom, Gregory Nazianzen and Augustine. Like the mothers of Jerome and Ambrose they gave luster to the womanhood of the early Christian centuries by their accomplishments and eminent piety. As defenders of the faith women stand side by side with Ignatius and Polycarp in their capacity to face death and endure the agonies of persecution. The roll of martyrs is made luminous by the unrivaled purity, undaunted heroism, unconquerable faith of such Christian maidens as Blandina, Potamiaena, Perpetua and Felicitas, who, in their loyalty to Christ, shrank not from the most fiendish tortures invented by the diabolical cruelties and hatred of pagan Rome.

In the growing darkness of subsequent centuries women, as mothers, teachers, abbesses, kept the light of Christian faith and intelligence burning in mediaeval Europe. The mothers of St. Bernard and Peter the Venerable witness to the conserving and creative power of their devotion and faith. The apotheosis of the Virgin Mother, though a grave mistake and a perversion of Christianity by substituting her for the true object of worship, nevertheless served, in opposition to pagan culture, to make the highest type of womanhood the ideal of mediaeval greatness. The full glory of humanity was represented in her. She became universally dominant in religion. The best royalty of Europe was converted through her influence. Poland and Russia were added to European Christendom when their rulers accepted the faith of their Christian wives. Clotilda's conversion of Clovis made France Christian. The marriage of Bertha, another Christian princess of France, to Ethelbert introduced Roman Christianity into England, which became the established religion when Edwin, in turn, was converted through the influence of his Christian wife. The process culminated, in the 19th cent., in the long, prosperous, peaceful, Christian reign of Victoria, England's noblest sovereign.

The opening decades of the 20th cent. are witnessing a movement among women that is one of the most remarkable phenomena in the history of mankind.

**3. Woman in the 20th Century**

It is world-wide and spontaneous, and aims at nothing less than woman's universal education and enfranchisement. This new ideal, taking its rise in the teaching of Jesus regarding the value of the human soul, is permeating every layer of society and all races and religions. Woman's desire for development and self-expression, and better still for service, has given birth to educational, social, eleemosynary, missionary organizations and institutions, international in scope and influence. In 75 years after Mary Lyon inaugurated the higher education of woman at Mt. Holyoke College, in 1837, 60,000 women were students in the universities and colleges of the United States; nearly 40,000 in the universities of Russia; and increasingly proportionate numbers in every higher institution of learning for women in the world; 30,000 were giving instruction in the primary and secondary schools of Japan. Even Moslem leaders confessed that the historic subjection of woman to ignorance, inferiority, and servitude was the fatal mistake of their religion and social system. The striking miracle occurred when Turkey and China opened to her the heretofore permanently closed doors of education and social opportunity.

This universal movement for woman's enlightenment and emancipation is significantly synchronous with the world-wide extension and success of Christian missions. The freedom liberated by Christ did set us free includes her complete liberation to equality of opportunity with man. In mental endowment, in practical ability, in all the higher ministries of life and even in statecraft, she has proved herself the equal of man. Christianity always tends to place woman side by side with man in all the great achievements of education, art, literature, the humanities, social service and missions. The entire movement of modern society toward her perfect enfranchisement is the distinct and inevitable product of

the teaching of Jesus. The growing desire of woman for the right of suffrage, whether mistaken or not, is the incidental outcome of this new emancipation. The initial stages of this evolutionary process are attended by many abnormal desires, crudities of experiment and conduct, but ultimately, under the guidance of the Spirit of God and the Christian ideal, woman will intelligently adjust herself to her new opportunity and environment, recognizing every God-ordained difference of function, and every complementary and cooperative relation between the sexes. The result of this latest evolution of Christianity will not only be a new womanhood for the race but, through her enlightenment, culture and spiritual leadership, a new humanity.

DWIGHT M. PRATT

**WONDER**, wun'dēr, **WONDERFUL**, wun'dērful: The vb. "wonder" occurs only a few times in the OT; "wonder" as noun is much more frequent, and is chiefly the tr of the word מֹפֶת, *mōphēth*, a splendid or conspicuous work, a "miracle" (Ex 4 21; 11 9, etc), often conjoined with 'ōthōth, "signs" (Ex 7 3; Dt 6 22; 13 1.2; 34 11; Neh 9 10, etc). Other frequent words are מֵפָלָא, *pālā'*, מֵפֶלֶא, *pelē'*, a "marvel," "miracle" (Ex 3 20; 15 11; Josh 3 5; Isa 9 6, m "wonderful counsellor," etc). In the NT the ordinary vb. is θαυμάζω, *thaumázō*, and the most frequent noun is τέρας, *téras*, a "marvel," "portent," answering in its meaning to Heb *pālā'*. As in the OT the "wonder" is chiefly a miraculous work, so in the Gospels the feeling of wonder is chiefly drawn out by the marvelous displays of Christ's power and wisdom (Mt 15 31; Mk 6 51; Lk 4 22, etc).

**Wonderful**, that which excites or calls forth wonder, is in the OT chiefly the tr of *pālā'* or *pelē'* (2 S 1 26; Ps 40 3; Isa 28 29, etc); in the NT of *thaumásios* (once, Mt 21 15).

For "wondered" in Lk 8 25; 11 14, RV has "marvelled" (cf 9 43); in the OT also "marvelous" frequently for "wondrous," etc (1 Ch 16 9; Job 9 10; Ps 96 3; 105 2). W. L. WALKER

**WOOD**, wōōd. See BOTANY; FOREST; TREES.

**WOOD OF EPHRAIM** (2 S 18 6). See EPHRAIM, FOREST OF.

**WOOF**, wōōf (עֵרֶב, 'ērebh, "mixture," "woof" [Lev 13 48 ff]). See WARP.

**WOOL**, wōōl (צֶמֶר, *çemer*; ἐρίον, *erion*): Wool and flax were the fibers most used by the ancient weavers. Wool was used principally for the outside garments (Lev 13 48 ff; Prov 31 13; Ezk 34 3; Hos 2 5.9). Syrian wool is found on the world's markets today, but it is not rated as first quality, partly because it is so contaminated with thorns, straw and other foreign matter which become entangled with the wool while the sheep are wandering over the barren, rocky mountain sides in search of food. Extensive pastures are almost unknown.

Two kinds of wool are sold: (1) That obtained by shearing. This is removed from the animal as far as possible in one piece or fleece usually without previous washing. The fleeces are gathered in bales and carried to a washing-place, which is usually one of the stony river beds, with but a small stream flowing through it during the summer. The river bed is chosen because the rocks are clean and free from little sticks or straw which would cling to the washed wool. The purchaser of this washed wool submits it to a further washing with soap, *ishnan* (alkali plant), "soapwort," or other cleansing agent (see FULLER), and then cards it before spinning and weaving. The wool thus obtained is nearly snow white. (2) The second supply of wool is from the tanneries where the wool is removed from the skins with slaked lime (see TANNING).



This is washed in many changes of water and used for stuffing mattresses, quilts, etc, but not for weaving.

Gideon used a fleece of wool to seek an omen from God (Jgs 6 37). Meshah, king of Moab, sent a large quantity of wool as a tribute to the king of Israel (2 K 3 4).

Wool was forbidden to be woven with linen (Dt 22 11; cf Lev 19 19). Priests could not wear woolen garments (Ezk 44 17). Wool dyed scarlet with the *kermes* was used in the blood-covenant ceremony (He 9 19; cf Lev 14; Nu 19 6).

The whiteness of wool was used for comparison (1) with snow (Ps 147 16); (2) with sins forgiven (Isa 1 18); (3) with hair (Dnl 7 9; Rev 1 14).

JAMES A. PATCH

**WORD**, wûrd: The commonest term in the OT for "word" is דָּבָר, *dābhār* (also "matter," "thing"); in the NT λόγος, *lógos* ("reason," "discourse," "speech"); but also frequently ῥῆμα, *rhēma*. *Rhēma* is a "word" in itself considered; *logos* is a *spoken word*, with reference generally to that which is in the speaker's mind. Some of the chief applications of the terms may thus be exhibited:

(1) We have the word of Jeh (or God; see below) (a) as the revelation to the patriarch, prophet, or inspired person (Gen 15 1; Ex 20 1; Nu 22 38, etc); (b) as spoken forth by the prophet (Ex 4 30; 34 1; 2 K 7 1; Isa 1 10, etc). (2) The word is often a commandment, sometimes equivalent to "the Law" (Ex 32 28; Nu 20 24; Dt 6 6; Ps 105 8; 119 11.17; Isa 66 2, etc). (3) As a promise and ground of hope (Ps 119 25.28.38, etc; 130 5, etc). (4) As creative, upholding, and preserving (Ps 33 6; cf Gen 1 3 ff; Ps 147 15.18; He 1 3; 11 3; 2 Pet 3 5.7). (5) As personified (in Apoc, Wisd 18 15; Ecclus 1 5, RVm "omitted by the best authorities"). (6) As personal (Jn 1 1). *Logos* in Philo and Gr-Jewish philosophy meant both reason or thought and its utterance, "the whole contents of the Divine world of thought resting in the *Noûs* of God, synonymous with the inner life of God Himself and corresponding to the *lógos endiáthetos* of the human soul; on the other hand, it is the externalizing of this as revelation corresponding to the *lógos prophorikós* in which man's thought finds expression" (Schultz). Cf also the references to Creation by "the word of God" and its personifications; see *Logos*; incarnated in Jesus Christ (Jn 1 14; 1 Jn 1 1.2; Rev 19 13, "His name is called, The Word of God," *Ho Lógos tou Theou*). See *PERSON OF CHRIST*. (7) Cannot be broken, endureth forever (2 K 10 10; Ps 119 89; Isa 40 8, etc). (8) A designation of the gospel of Christ: sometimes simply "the word"; with Jesus "the word of the Kingdom" (Mt 13 19; Mk 2 2; Acts 4 4.29.31, etc). In John's Gospel Jesus frequently speaks of His "word" and "works" as containing the Divine revelation and requirements made through Him, which men are asked to believe in, cherish and obey (Jn 5 24; 6 63.68, etc); "the words of God" (Jn 3 34; 8 47; 14 10; 17 8.14, etc); His "word" (*logos* and *rhēma*) is to be distinguished from *lalia*, speech (cf Mt 26 73; Mk 14 70), tr<sup>d</sup> "saying," Jn 4 42 (ver 41, "Many more believed because of his own word" [*logos*]; ver 42, "not because of thy saying" [*lalia*], RV "speaking"); in the only other occurrence of *lalia* in this Gospel (8 43) Jesus uses it to distinguish the outward expression from the inner meaning, "Why do ye not understand my speech?" (*lalia*), "Even because ye cannot hear my word" (*logos*). (9) "Words" are distinguished from "power" (1 Cor 4 20; 1 Thess 1 5); are contrasted with "deed" (Mal 2 17; 1 Cor 4 20; 1 Jn 3 18). (10) Paul refers to "unspeakable words" (*árrhēta rhēmata*) which he heard in

Paradise (2 Cor 12 4), and to "words [*logoi*] . . . which the Spirit teacheth" (1 Cor 2 13).

For "word" RV has "commandment" (Nu 4 45, etc); for "words," "things" (Jn 7 9; 8 30; 9 22.40; 17 1); "sayings" (Jn 10 21; 12 47.48); for "enticing words," "persuasiveness of speech" (Col 2 4); conversely, "word" for "commandment" (Nu 24 13; 27 14; Josh 8 8, etc), with numerous other changes.

W. L. WALKER

**WORK, wûrk, WORKS, wûrks**: "To work" in the OT is usually the tr of עָשָׂה, *ʿāsah*, or of עָבַד, *pā'al* (of the works both of God and of man), and "work" (noun) is most frequently the tr of עֲשָׂוֹת, *ma'āseh*, or עֲשָׂוֹתָי, *mā'ā'khāh*; in the NT of ἐργεῖον, *energēō*, ἐργάματα, *ergázomai* (and compound), with ἔργον, *érgon* (noun). The word "works" (*érge*) is a favorite designation in Jn for the wonderful works of Jesus (5 36; 10 38; 15 24, etc; "miracles" to us, "works" to Him). "Works" is used by Paul and James, in a special sense, as denoting (with Paul) those legal performances by means of which men sought to be accepted of God, in contradistinction to that faith in Christ through which the sinner is justified apart from all legal works (Rom 3 27; 4 2.6, etc; Gal 2 16; 3 2.5.10), "working through love" (Gal 5 6; 1 Thess 1 3), and is fruitful in all truly "good works," in which Christian believers are expected to abound (2 Cor 9 8; Eph 2 10; Col 1 10; 2 Thess 2 17, etc). When James speaks of being justified by "works" as well as by "faith" (2 14-26), he has in view those works which show faith to be real and vital. "Dead works" avail nothing (cf He 9 14; 10 24). Judgment is according to "works" (Mt 16 27, RV "deeds," m "Gr 'doing,'" *práxis*; Rom 2 6; 1 Pet 1 17, etc), the new life being therein evidenced. A contrast between "faith" and "good works" is never drawn in the NT. See, further, *JUSTIFICATION*. W. L. WALKER

**WORKER, wûr'kēr, WORKFELLOW, wûrk'-fel-ō, WORKMAN, wûrk'man** (עָבַד, *hārāsh*, עֲשָׂוֹת, *pā'al*; ἐργάτης, *ergátēs*, συνεργός, *sunergós*): "Worker" (artificer) is the tr of *hārāsh*, "to cut in" (1 K 7 14, "a worker in brass"), and of *hārāsh*, "artificer," etc (1 Ch 22 15); "workers of stone," rendered "workman," "workmen" (Isa 40 20; 44 11; Jer 10 3.9, "artificer"; Hos 8 6); *ʿāsah*, "to work," is tr<sup>d</sup> "workers" of iniquity (Ps 37 1, "them that work unrighteousness"); *ʿāsah mā'ā'khāh*, "to do work" (2 K 12 14.15, "workmen," "them that did the work"; 1 Ch 22 15; 2 Ch 24 13, etc; Ezr 3 9); *an'shē mā'ā'khāh*, "men of work" (1 Ch 25 1, "workmen," "them that did the work"); *āmēl*, "working," "toiling" (Jgs 5 26, "put . . . her right hand to the workmen's hammer"); *pā'al*, "to act," "do," when tr<sup>d</sup> "workers," is joined with "iniquity," "workers of iniquity" (Job 31 3; 34 8.22; Ps 5 5; 6 8; 14 4, etc; Prov 10 29; 21 15); *ergátēs*, "worker," is tr<sup>d</sup> "workman" (Mt 10 10, "laborer"; 2 Tim 2 15; Acts 19 25), "workers" (of iniquity) (Lk 13 27), "deceitful workers" (2 Cor 11 13), "evil workers" (Phil 3 2); *dynamis*, "power," is tr<sup>d</sup> "[workers of] miracles" (1 Cor 12 29 m, RV "powers"); *sunergēō*, "to work with" (2 Cor 6 1, "working together with him").

Workfellow is the tr of *sunergos*, "joint or fellow-worker" (Rom 16 21; Col 4 11).

Workmaster occurs in Ecclus 38 27, as the tr of *architéklōn*.

For "of ["with"] cunning work" (Ex 26 1.31; 28 6.15; 36 8.35; 39 3.8), ARV has "the work of the skillful workman," ERV "of the cunning workman"; instead of "I was by him as one brought up [with him]" (Prov 8 30), RV has "I was by him as a master workman."

W. L. WALKER

**WORLD**, wŭrlđ (COSMOLOGICAL, koz-mŏ-loj'-i-kał):

1. Terms and General Meaning
2. Hebrew Idea of the World
3. Its Extent
4. Origin of the World—Biblical and Contrasted Views
5. The Cosmogony of Gen 1—Comparison with Babylonian and Other Cosmogonies
6. Gen 1 and Science

#### LITERATURE

The Hebrews had no proper word for "world" in its wide sense of "universe." The nearest approach to such a meaning is in the phrase "the heavens and the earth" (Gen 1 1, etc). Even this, in a physical reference, does not convey the modern idea, for the earth is still the center with which heaven and the heavenly bodies are connected as adjuncts. It is here, however, to be remembered that to the Hebrew mind the physical world was not the whole. Beyond were the heavens where God's throne was, peopled by innumerable spiritual intelligences, whose hosts worshipped and obeyed Him (Gen 28 12; Ps 103 19-21, etc). Their conception of the universe was thus enlarged, but the heavens, in this sense, would not be included in the "world." For "world," in its terrestrial meaning, several Hebrew words are used. The AV thus occasionally renders the word *'erec*, "earth" (the rendering is retained in RV in Isa 23 17; Jer 25 26; in Ps 22 27; Isa 62 11, it is changed to its proper meaning "earth"); *'olām*, "age," twice rendered "world" in AV (Ps 73 12; Eccl 3 11), is changed in RV—in the latter case into "eternity." The chief word for "world" in the sense of the habitable earth, the abode of man, with its fulness of created life, is *tebhēl*—a poetical term (1 S 2 8; 2 S 22 16; Job 13 18; 34 13; 37 12; Ps 9 8; 18 15, etc)—answering to the Gr *oikouménē*.

In the NT a frequent word for "world" is *aion*, "age" (Mt 12 32; 13 22,39,40,49; 24 3; Mk 4 19; Lk 16 8; Rom 12 2; He 1 2, etc). RV notes in these cases "age" in m, and sometimes changes in text into "of old" (thus ARV in Lk 1 70; Acts 3 21), "ages," "times," etc, according to the sense (cf 1 Cor 10 11; He 6 5; 9 26; 2 Tim 1 9; Tit 1 2, etc). Most generally the Gr word used is *kósmos*, the "ordered world" (e.g. Mt 4 8; 5 14; 26 13; Mk 8 36; Jn 1 9; 8 12; Acts 17 24; Rom 1 8,20, etc). The wider sense of "all creation," or "universe" (see above on the OT), is expressed by such phrases as *pánta*, "all things" (Jn 1 3), *pása hē ktisis*, "the whole creation" (Rom 8 22).

Two errors are to be avoided in framing a representation of the Heb conception of the world. (1) The attempt should not be made to find in the Bib. statements precise anticipations of modern scientific discoveries. The relations of the Bib. teaching to scientific discovery are considered below. Here it is enough to say that the view taken of the world by Bib. writers is not that of modern science, but deals with the world simply as we know it—as it lies spread out to ordinary view—and things are described in popular language as they appear to sense, not as telescope, microscope, and other appliances of modern knowledge reveal their nature, laws and relations to us. The end of the narration or description is through-out religious, not theoretic. (2) On the other hand, the error is to be avoided of forcing the language of popular, often metaphorical and poetic, description into the hard-and-fast forms of a cosmogony which it is by no means intended by the writers to yield. It is true that the Hebrews had no idea of our modern Copernican astronomy, and thought of the earth as a flat surface, surmounted by a vast ex-

pense of heaven, in which sun, moon and stars were placed, and from whose reservoirs of rain this descended. But it is an exaggeration of all this to speak, as is sometimes done, as if the Hebrews were children who thought of the sky as a solid vault (Gen 1 6-8; Job 37 18), supported on pillars (Job 26 11), and pierced with windows (Gen 7 11; Isa 24 18), through which the rains came. "The world is a solid expanse of earth, surrounded by and resting on a world-ocean, and surmounted by a rigid vault called the 'firmament,' above which the waters of a heavenly ocean are spread" (Skinner). The matter is carried farther when elaborate resemblances are sought between the Heb and Bab cosmogonies (see below). Such representations, though common, are misleading. Language is not to be pressed in this prosaic, unelastic way. It is forgotten that if the "firmament" or "heaven" is sometimes spoken of as a solid vault, it is at other times compared to a "curtain" stretched out (Ps 104 2; Isa 40 22), or a "scroll" that can be rolled up (Isa 34 4); if "windows" of heaven are once or twice mentioned, in many other places there is a quite clear recognition that the rain comes from the clouds in the air (Jgs 5 4; Job 36 28; Ps 77 17, etc); if the earth is sometimes spoken of as a "circle" (Isa 40 22), at other times it has "corners" and "ends" (Isa 11 12; Dt 33 17; Job 37 3; Ps 19 6, etc); if sun, moon and stars are figured as if attached to the firmament—"fixed as nails," as one has put it—"from which they might be said to drop off" (Isa 14 12, etc), far more frequently the sun is represented as pursuing his free, rejoicing course around the heavens (Ps 19 5,6, etc), the moon as "walking" in brightness (Job 31 26), etc. The proper meaning of the word *rākīa'* is simply "expanse," and the pellucid vault of the heavens, in which the clouds hung, and through which the sun traveled, had probably for the Hebrews associations not very different from what it has to the average mind of today. The earth, itself composed of "dry land" and "seas" (Gen 1 9,10), the former with its mountains, valleys and rivers, may have been conceived of as encircled by an ocean—the circular form being naturally suggested by the outline of the horizon. A few passages convey the idea of depths within or beneath, as well as around the solid earth (Gen 7 11; Dt 33 13)—a thought again suggested by springs, wells, floods, and similar natural phenomena—but there is no fixity in these representations. One place in Job (26 7) has the bold idea of the earth as hung in free space—a near approach to the modern conception.

The ideas formed of the extent of the world were naturally limited by the geographical knowledge of the Hebrews, and expanded as that knowledge increased. At no time, however, was it so limited as might be supposed. The TABLE OF NATIONS (q.v.) in Gen 10 shows a wide knowledge of the different peoples of the world, "after their tongues, in their lands, in their nations" (vs 20,31). The outlook to the W. was bounded by the Mediterranean ("great sea," Nu 34 6; Ezk 47 10, etc), with its "islands" (Gen 10 5; Isa 11 11, etc), to Tarshish (Spain?) in the extreme W. To the N. was the great empire of the Hittites (Josh 1 4; 1 K 10 29, etc). N. and E., across the desert, beyond Syria, lay the familiar region of Mesopotamia (Aram-Naharaim, Ps 60, title), with Ararat (Gen 8 4) still farther N.; and, southward, in the Tigris-Euphrates valley, the ancient and powerful empires of Assyria and Babylonia (Gen 2 14; 10 10,11), with Media and Elam (Gen 10 2,22), at a later time Persia (Est 1 1), farther E. To the S.E., between the Red Sea and the Pers Gulf, lay the great peninsula of Arabia, and to the W. of the Red Sea, S.W. of Canaan, the mighty Egypt, Israel's never-forgotten "land of bondage" (Ex 20 2, etc). S. of Egypt was Ethiopia. Of more distant peoples, India is first mentioned in Est 1 1; 8 9, but trade with it must have been as early as the days of Solomon. On the dim horizon are such peoples as Gomer (the Cimmerians, N. of the Euxine, Gen 10 2; Ezk 38 6) and Magog (Gen 10 2; Ezk 38 2, the Scythians [?]); probably even China is intended by "the land of Sinim" in Isa 49 12. In the

#### 2. Hebrew Idea of the World

The attempt should not be made to find in the Bib. statements precise anticipations of modern scientific discoveries. The relations of the Bib. teaching to scientific discovery are considered below. Here it is enough to say that the view taken of the world by Bib. writers is not that of modern science, but deals with the world simply as we know it—as it lies spread out to ordinary view—and things are described in popular language as they appear to sense, not as telescope, microscope, and other appliances of modern knowledge reveal their nature, laws and relations to us. The end of the narration or description is through-out religious, not theoretic. (2) On the other hand, the error is to be avoided of forcing the language of popular, often metaphorical and poetic, description into the hard-and-fast forms of a cosmogony which it is by no means intended by the writers to yield. It is true that the Hebrews had no idea of our modern Copernican astronomy, and thought of the earth as a flat surface, surmounted by a vast ex-

apocryphal books and the NT the geographical area is perceptibly widened. Particularly do Asia Minor, Macedonia, Greece and Italy, with their islands, cities, etc., come clearly into view. A list like that in Acts 2 9-11 of the representatives of peoples present at the day of Pentecost gives a vivid glimpse of the extent of the Jewish religious connection at this period (cf Acts 8 27 ff.).

From the first there has been abundant speculation in religion and philosophy as to how the world came to be—whether it was eternal, or had a commencement, and, if it began to be, how it originated. Theories were, as they are still, numberless and varied. Some cosmogonies were purely mythological (Bab, Hesiod); some were materialistic (Democritus, Epicurus—"concourse of atoms"); some were demiurgic (Plato in *Timaeus*—an eternal matter formed by a demiurge); some were emanational (Gnostics—result of overflowing of fulness of Divine life in "aeons"); some were dualistic (Parsism, Manicheism—good and evil principles in conflict); some imagined endless "cycles"—alternate production and destruction (Stoics, Buddhist *kalpas*); many were pantheistic (Spinoza—an eternal "substance," its "attributes" necessarily determined in their "modes"; Hegel, "absolute spirit," evolving by logical necessity); some are pessimistic (Schopenhauer—the world the result of an irrational act of "will"; hence necessarily evil), etc.

In contrast with these conflicting, and often foolish and irrational, theories, the Bib. doctrine of the origin of the world stands alone and unique. It is unique because the view of God on which it rests is unique. According to the teaching of the Bible, from its first page to its last, God is a free, personal Spirit, one, omnipotent, holy, and the world originates in a free act of His almighty will (Gen 1 1; Ps 33 9; He 11 3; Rev 4 11, etc.), is continually upheld by His power, ruled by His providence, and is the sphere of the realization of His purpose. As against theories of the eternity of the world, accordingly, it declares that the world had a beginning (Gen 1 1); as against dualism, it declares that it is the product of one almighty will (Dt 4 35; Isa 45 7; 1 Cor 8 6, etc.); as against the supposition of an eternal matter, it declares that matter as well as form takes its origin from God (Gen 1 1; He 11 3); as against pantheism and all theories of necessary development, it affirms the distinction of God from His world, His transcendence over it as well as His immanence in it, and His free action in creation (Eph 4 6; Rev 4 11); as against pessimism, it declares the constitution, aim and end of the world to be good (Gen 1 31; Ps 33 5; Mt 5 45, etc.). To the OT doctrine of the origin of the world the NT adds the fuller determination that the world was created through the agency of the "Word" (Logos), or Son (Jn 1 3; Col 1 16, 17; He 1 2, 3, etc.).

No stronger proof could be afforded of the truth and singularity of the Bib. account of the origin of things than is given by the comparison of the narrative of creation in Gen 1—2 4, with the mythological cosmogonies 1—Comparison of these the best known, up to the time of recent discoveries, were the Bab account of the creation preserved by Berosus, a priest of Babylon in the 3d cent. BC, and the *Theogony* of the Gr Hesiod (9th cent. BC). Hesiod's

poem is a confused story of how from Chaos came forth Earth, Tartarus (Hell), Eros (Love) and Erebus (Night). Erebus gives birth to Aether (Day). Earth produces the Heaven and the Sea. Earth and Heaven, in turn, become the parents of the

elder gods and the Titans. Cronus, one of these gods, begets Zeus. Zeus makes war on his father Cronus, overthrows him, and thus becomes king of the Olympian gods. The descent of these is then traced. How far this fantastic theory, commencing with Chaos, and from it generating Nature and the gods, has itself an original affinity with Bab conceptions, need not here be discussed. It hardly surpasses in crudeness the late shape of the Bab cosmogony furnished by Berosus. Here, too, Chaos—"darkness and water"—is the beginning, and therefrom are generated strange and peculiar forms, men with wings and with two faces, or with heads and horns of goats, bulls with human heads, dogs with four bodies, etc. Over this welter a woman presides, called Omorka. Belus appears, cuts the woman in twain, of one half of her makes the heavens, and of the other the earth, sets the world in order, finally makes one of the gods cut off his head, and from the blood which flowed forth, mixed with earth, forms intelligent man. That Berosus has not essentially misrepresented the older Bab conceptions is now made apparent through the recovery of the Bab story itself.

In 1875 George Smith discovered, among the tablets in the British Museum brought from the great library of the Assyrian king Assurbanipal (7th cent. BC), several on which was inscribed the Chaldaean story of creation, and next year published his work, *The Chaldaean Account of Gen.* The tablets, supplemented by other fragments, have since been repeatedly <sup>and</sup> by other hands, the most complete <sup>tr</sup> being that by L. W. King in his *Seven Tablets of Creation in the Babylonian and Assyrian Legends concerning the Creation of the World.* The story of these tablets, still in many parts fragmentary, is now familiar (see BABYLONIAN RELIGION AND LITERATURE). Here, too, the origin of all things is from Chaos, the presiding deities of which are Apsu and Tiamat. The gods are next called into being. Then follows a long mythological description, occupying the first four tablets, of the war of Marduk with Tiamat, the conflict issuing in the woman being cut in two, and heaven being formed of one half and earth of the other. The 5th tablet narrates the appointing of the constellations. The 6th seems to have recorded the creation of man from the blood of Marduk. This mythological epic is supposed by many scholars to be the original of the sublime, orderly, monotheistic account of the creation which stands at the commencement of our Bible. The Bab story is (without proof) supposed to have become naturalized in Israel, and there purified and elevated in accordance with the higher ideas of Israel's religion. We cannot subscribe to this view, which seems to us loaded with internal and historical improbabilities. Points of resemblance are indeed alleged, as in the use of the Heb word *ḥōm* for "deep" (Gen 1 2), cognate with Tiamat; the separation of heaven and earth (Gen 1 6-8); the appointing of the constellations (Gen 1 14-18), etc. But in the midst of the scanty resemblances, how enormous are the contrasts, which all writers acknowledge! Gunkel, e.g., says, "Anyone who compares this ancient Bab myth with Gen 1, will perceive at once hardly anything else than the infinite distance between them. There the heathen gods, inflamed against each other in wild warfare, here the One, who speaks and it is done" (*Israel and Babylonien*, 24). One can understand how these wild polytheistic legends could arise from corruption of a purer, simpler form, but not vice versa. The idea of a "deep," or chaos, must have preceded the fanciful and elaborate creation of the woman-monster, Tiamat; the distinction of sky and earth would go before the coarse idea of the cutting of the woman in two; and so with the other features of supposed resemblance. Professor Clay has recently shown reason for challenging the whole idea of the borrowing of these myths from Babylon, and declares that "it is unreasonable to assume that the Heb *ḥōm* is a modification of a Bab pattern. . . . To say, therefore, that the origin of the Marduk-Tiamat myth is to be found in a Nippurian version, originally known as Ellil-Tiamat, is utterly without foundation" (*Amurru*, 50). Much more reasonably may we adopt the hypothesis of Dillmann, Kittel, Hommel, Oetli, etc., that the relation between these Bab legends and the Bib. narratives is one of cognateness, and not of derivation. These traditions came down from a much older source and are preserved by the Hebrews in their purer form (see the writer's *POT*, 402-9).

The superiority of the Gen cosmogony to those of other peoples is generally admitted, but objection to it is taken in the name of modern science. The narrative conflicts, it is said, with both modern astronomy and modern geology; with the former, in

regarding the earth as the center of the universe, and with the latter in its picture of the order and stages of creation, and the time occupied in the work (for a full statement and Science of these alleged discrepancies, see Dr. Driver's *Gen*, Intro). On the general question of the harmony of the Bible with science it is important that a right standpoint be adopted. It has already been stated that it is no part of the aim of the Bib. revelation to anticipate the discoveries of 19th- and 20th-cent. science. The world is taken as it is, and set in its relations to God its Creator, without consideration of what after-light science may throw on its inner constitution, laws and methods of working. As Calvin, with his usual good sense, in his comm. on Gen 1 says, "Moses wrote in the popular style, which, without instruction, all ordinary persons endowed with common sense are able to understand. . . . He does not call us up to heaven; but only proposes things that lie open before our eyes." This of itself disposes of the objection drawn from astronomy, for everywhere heaven and earth are spoken of according to their natural appearances, and not in the language of modern Copernican science. To this hour we use the same language in speaking of the sun rising and setting.

The further objection that modern knowledge discredits the Bib. view by showing how small a speck the world is in the infinitude of the universe is really without force. Whatever the extent of the universe, it remains the fact that on this little planet life has effloresced into reason, and we have as yet no ground in science for believing that anywhere else it has ever done so (cf Dr. A. R. Wallace's striking book, *Man's Place in the Universe*). Even supposing that there are any number of inhabited worlds, this does not detract from the soul's value in this world, or from God's love in the salvation of its sinful race. The objection drawn from geology, though so much is sometimes made of it, is hardly more formidable. It does not follow that, because the Bible does not teach modern science, we are justified in saying that it contradicts it. On the contrary, it may be affirmed, so true is the standpoint of the author in this first chapter of Gen, so Divine the illumination with which he is endowed, so unerring his insight into the order of Nature, that there is little in his description that even yet, with our advanced knowledge, we need to change. To quote words used elsewhere, "The dark watery waste over which the Spirit broods with vivifying power, the advent of light, the formation of an atmosphere or sky capable of sustaining the clouds above it, the settling of the great outlines of the continents and seas, the clothing of the dry land with abundant vegetation, the adjustment of the earth's relation to sun and moon as the visible rulers of its day and night, the production of the great sea-monsters and reptile-like creatures and birds, the peopling of the earth with four-footed beasts and cattle, last of all, the advent of man—is there so much of all this which science requires us to cancel?" (Orr, *Christian View of God and the World*, 421).

Even in regard to the "days"—the duration of time involved—there is no insuperable difficulty. The writer may well have intended symbolically to represent the creation as a great week of work, ending with the Creator's Sabbath rest. In view, however, of the fact that days of 24 hours do not begin to run till the appointment of the sun on the 4th day (Gen 1 14), it seems more probable that he did not intend to fix a precise length to his creation "days." This is no new speculation. Already Augustine asks, "Of what fashion these days were it is exceeding hard or altogether impossible to think, much more to speak" (*De Civ. Dei*,

xi.6, 7); and Thomas Aquinas in the Middle Ages leaves the matter an open question. Neither does this narrative, in tracing the origin of all things to the creative word of God, conflict with anything that may be discovered by science as to the actual method of creation, e.g. in evolution. Science itself is gradually coming to see the limits within which the doctrine of evolution must be received, and, kept within these limits, there is nothing in that doctrine which brings it into conflict with the Bib. representations (see ANTHROPOLOGY; CREATION; EVOLUTION; also the writer's works, *God's Image in Man and Sin as a Problem of Today*). Whatever may be said of the outward form of the narrative, one has only to look at the great ideas which the first chapter of Gen is intended to teach to see that it conveys those great truths on the origin and ordering of things which are necessary as the basis of a true religious view of the world, no matter to what stage knowledge or science may attain. This chapter, standing at the head of the Bible, lays the foundation for all that follows in the Bib. view of the relation of God to the world, and yields the ground for our confidence that, as all things are created by God and dependent on Him, so everything in Nature and providence is at His disposal for the execution of His purposes and the care and protection of His people. The story of creation, therefore, remains to all time of the highest religious value.

LITERATURE.—See arts. "Earth" in Smith's *DB* and in *EB*. The other works mentioned above may be consulted. A valuable extended discussion of the word "Firmament" may be seen in Essay V of the older work, *Aids to Faith* (London, Murray), 220-30.

JAMES ORR

**WORLD, END OF THE.** See ESCHATOLOGY OF THE NT; HEAVENS, NEW.

**WORLD (GENERAL):** In AV this word represents several originals, as follows: עֵרֶץ, 'erec, "earth";

הַיָּדֵל, *hedhel*, "the underworld"; הָאֵלֶם, *alām*, "indefinite time," "age"; תְּבִיֵל, *tēbhēl*, "fertile earth"; γῆ, *gē*, "earth"; αἰὼν, *aiōn*, "age," "indefinite time," with frequent connotation of the contents of time, its influences and powers; οἰκουμένη, *oikoumenē*, "inhabited earth," the world of man considered in its area and distribution; last, and most frequently, κόσμος, *kósmos*, properly "order," with the suggestion of beauty; thence the *material universe*, as the great example of such order; then the *moral universe*, the total system of intelligent creatures, perhaps sometimes including angels (1 Cor 4 9), but as a rule human beings only; then, in view of the fact of universal human failure, humanity in its sinful aspect, the spirit and forces of fallen humanity regarded as antagonistic to God and to good, "all around us which does not love God."

Of the above terms, some need not detain us; 'erec, as the original to "world," occurs only thrice, *hedhel*, once, *heledh*, twice, 'alām, twice

**2. Remarks** (including Eccl 3 11), *gē*, once. The most important of the series, looking at frequency of occurrence, are *tēbhēl*, *aiōn*, *oikoumenē*, *kosmos*. On these we briefly comment in order.

(1) *Tēbhēl*.—This, as the original to "world," occurs in 35 places, of which 15 are found in Pss and 9 in the first half of Isa. By derivation it has to do with produce, fertility, but this cannot be said to come out in usage. The word actually plays nearly the same part as "globe" with us, denoting man's material dwelling-place, as simply as possible, without moral suggestions.

(2) *Aiōn*.—We have indicated above the speciality of this word. It is a *time*, with the suggestion always of *extension* rather than limit (so that it

lends itself to phrases denoting vast if not endless extension, such as "to the *aïōns* of *aïōns*," rendered "forever and ever," or "world without end"). In He 1 2; 11 13, it denotes the "aeons" of the creative process. In numerous places, notably in Mt, it refers to the "dispensations" of redemption, the present "age" of grace and, in distinction, the "age" which is to succeed it—"that world, and the resurrection" (Lk 20 35). Then, in view of the moral contents of the present state of things, it freely passes into the thought of forces and influences tending against faith and holiness, e.g., "Be not fashioned according to this world" (Rom 12 2). In this connection the Evil Power is said to be "the god of this world" (2 Cor 4 4).

(3) The word *oikoumenē* occasionally means the Rom empire, regarded as preëminently the region of settled human life. So Lk 2 1; Acts 11 28, and perhaps Rev 3 10, and other apocalyptic passages. In He it is used mystically of the Empire of the Messiah (1 6; 2 5).

(4) *Kosmos*.—We have remarked above on this word, with its curious and suggestive history of meanings. It may be enough here to add that that history prepares us to find its reference varying by subtle transitions, even in the same passage. See e.g. Jn 1 10, where "the world" appears first to denote earth and man simply as the creation of "the Word," and then mankind as sinfully alienated from their Creator. We are not surprised accordingly to read on the one hand that "God . . . loved the world" (Jn 3 16), and on the other that the Christian must "not love the world" (1 Jn 2 15). The reader will find the context a sure clue in all cases, and the study will be pregnant of instruction.

HANDLEY DUNELM

**WORM**, wûrm, **SCARLET-WORM**, skâr'let-wûrm: (1) תוֹלַעַת, *tôlâ'*, תוֹלַעְתָּהּ, *tôlê'ah*, תוֹלַעְתָּהּ, *tôlâ'ath*, תוֹלַעְתָּהּ, *tôlâ'ath*, from √ תָּלַעַע, *tâla'*; of Arab.

تَلَع, *tala*, "to stretch the neck"; usually with شָׁנִי, *shānī*, "bright" (cf Arab. سَنَى, *sanā*, "a flash of lightning"), the term תוֹלַעְתָּהּ, *tôlâ'ath shānī* being tr<sup>d</sup> "scarlet" in EV; also in the same sense the following: שְׁנֵי תוֹלַעְתָּהּ, *shēnī tôlâ'ath* (Lev 14 4), תוֹלַעַת, *tôlâ'* (Isa 1 18, EV "crimson"), שְׁנֵימ, *shānīm* (Prov 31 21; Isa 1 18, EV "scarlet"), שְׁנֵי, *shānī* (Gen 38 28; Josh 2 18; Cant 4 3); also κόκκος, *kókkos*, and κόκκινος, *kókkinos* (Mt 27 28; He 9 19; Rev 17 3.4; 18 12.16). (2) רִמְמָהּ, *rimmāh*, from √ רָמַם, *rāmam*, "to putrefy" (Ex 16



Scarlet Insect.

20); cf Arab. رَمِمَ, *ramim*, "to become carious" (of bone). (3) שָׂשׁ, *šāš* (only in Isa 51 8); cf Arab. سوس, *sūs*, "worm"; שָׂשׁ, *sēs*, "moth" (Mt 6 19). (4) זֹחְלִים, *zohālīm* (Mic 7 17, AV "worms," RV "crawling things"), from √ זָחַל, *zāhal*, "to crawl." (5) σκώληξ, *skōlēx* (Mk 9 48), σκωληκόβρωτος, *skōlēkōbrōtos*, "eaten of worms" (Acts 12 23).

Besides the numerous passages, mostly in Ex, referring to the tabernacle, where *tôlâ'ath*, with *shānī*, is tr<sup>d</sup> "scarlet," there are eight passages in

which it is tr<sup>d</sup> "worm." These denote worms which occur in decaying organic matter or in sores (Ex 16 20; Isa 14 11; 66 24); or which are destructive to plants (Dt 28 39; Jon 4 7); or the word is used as a term of contempt or depreciation (Job 25 6; Ps 22 6; Isa 41 14). *Rimmāh* is used in the same senses. It occurs with *tôlâ'ath* as a synonym in Ex 16 24; Job 25 6; Isa 14 11. In Job 25 6, EV, rendering both *tôlâ'ath* and *rimmāh* by "worm," 'ēnōsh and 'ādhām by "man," and introducing twice "that is a," makes a painfully monotonous distich out of the concise and elegant original, in which not one word of the first part is repeated in the second. *Šāš* (Isa 51 8), EV "worm," is the larva of the clothes-moth. See MOTH. In none of the cases here considered are worms, properly so called, denoted, but various insect larvae which are commonly called "worms," e.g. "silkworm," "apple-worm," "meal-worm," etc. These larvae are principally those of *Diptera* or flies, *Coleoptera* or beetles, and *Lepidoptera* or butterflies and moths.

*Tôlâ'ath shānī*, "scarlet," is the scarlet-worm, *Cermes vermilio*, a scale-insect which feeds upon the oak, and which is used for producing a red dye. It is called by the Arabs *ādāh*, "a worm," a word also used for various insect larvae. It is also called *kirmā*, whence "crimson" and the generic name *Cermes*. This scarlet-worm or scale-insect is one of the family *Coccidae* of the order *Rhynchota* or *Hemiptera*. The female is wingless and adheres to its favorite plant by its long, sucking beak, by which it extracts the sap on which it lives. After once attaching itself it remains motionless, and when dead its body shelters the eggs which have been deposited beneath it. The males, which are smaller than the females, pass through a complete metamorphosis and develop wings. The dye is made from the dried bodies of the females. Other species yielding red dyes are *Porphyrophora polonica* and *Coccus cacti*. The last named is the Mexican cochineal insect which feeds on the cactus and which largely supplanted the others after the discovery of America. Aniline dyes have in turn to a great extent superseded these natural organic colors, which, however, continue to be unsurpassed for some purposes. See COLORS.

ALFRED ELY DAY



Wormwood (*Artemista absinthium*).

**WORMWOOD**, wûrm'wōod (רִמְמָהּ, *la'ānāh* [Dt 29 18; Prov 5 4; Jer 9 15; 23 15; Lam 3 15.19; Am 5 7; 6 12, AV hemlock]; ἄψινθος, *apsinthos*

[Rev 8 11]: What the Heb *la'ānāh* may have been is obscure; it is clear it was a bitter substance and it is usually associated with "gall"; in LXX it is variously tr<sup>d</sup>, but never by *apsinthos*, "wormwood." Nevertheless all ancient tradition supports the EV tr. The genus *Artemisia* (N.O. *Compositae*), "wormwood," has five species of shrubs or herbs found in Pal (Post), any one of which may furnish a bitter taste. The name is derived from the property of many species acting as anthelmintics, while other varieties are used in the manufacture of absinthe.

E. W. G. MASTERMAN

**WORMWOOD, THE STAR:** In Rev 8 11, the name is figurative, given to a great star which, at the sounding of the third angel's trumpet, fell from heaven upon the third part of the rivers and on the fountains of the waters, turning them to a bitterness of which many died. Wormwood is used of bitter calamities (cf Lam 3 15), and may here indicate some judgment, inflicted under a noted leader, affecting chiefly the internal sources of a country's prosperity. Older expositors, applying the earlier trumpets to the downfall of the Rom empire, saw in the star a symbol of the barbarian invasions of Attila or Genseric. See also ASTRONOMY, I, 8.

JAMES ORR

**WORSHIP**, wūr'ship (AS *weorthscipe*, *wyrthscype*, "honor," from *weorth*, *wurth*, "worthy," "honorable," and *scipe*, "ship"):

1. Terms
  2. OT Worship
  3. NT Worship
  4. Public Christian Worship
- LITERATURE

Honor, reverence, homage, in thought, feeling, or act, paid to men, angels, or other "spiritual" beings, and figuratively to other entities, ideas, powers or qualities, but specifically and supremely to Deity.

The principal OT word is שָׁחָה, *shāhāh*, "depress," "bow down," "prostrate" (Hithpael), as in Ex 4 31, "bowed their heads and worshipped"; so in 94 other places. The context determines more or less clearly whether the physical act or the volitional and emotional idea is intended. The word is applied to acts of reverence to human superiors as well as supernatural. RV renders it according to its physical aspect, as indicated by the context, "bowed himself down" (AV "worshipped," Gen 24 52; cf 23 7; 27 29, etc).

Other words are: שָׁחָה, *shāhāh*, "prostrate," occurring in Isa 44 15.17.19; 46 6, but rendered (EV) "fall down." In Dnl 2 46; 3 5.6.7.10.15.18.28, it (Aram. שָׁחָה, *shāhāh*) is "worship" (EV), 7 t associated with "falling down," and 5 t with "serve." עָבַד, *ābād*, "work," "labor," "serve," is rendered "worship" by EV in 2 K 10 19.21 ff: "the worshippers [servants] of Baal." In Isa 19 21 RV has "worship with sacrifice and oblation" (AV "do sacrifice"). Isa 19 23 AV has "served," RV "worship." עָצַב, *ācāb*, "carve," "fabricate," "fashion," is once given "worship," i.e. "make [an object of] worship" (Jer 44 19, ARV m "portray").

The OT idea is therefore the reverential attitude of mind or body or both, combined with the more generic notions of religious adoration, obedience, service. The principal NT word (59 t) is προσκυνέω, *proskunēō*, "kiss [the hand or the ground] toward," hence often in the oriental fashion bowing prostrate upon the ground; accordingly, LXX uses it for the Hithpael of *shāhāh* (*hishthāhāwāh*), "prostrate oneself." It is to render homage to men, angels, demons, the devil, the "beast," idols, or to God. It is rendered 16 t to Jesus as a beneficent superior; at least 24 t to God or to Jesus as God. The root idea of bodily prostration is much less prominent than in the OT. It is always tr<sup>d</sup> "worship."

Next in frequency is σέβωμαι, *sēbōmai*, "venerate," and its various cognates, σέβασμαι, *sēbāzōmai*, εὐσεβέω, *eusebēō*, θεοσεβής, *theosebēs*, σέβασμα, *sēbasma*. Its root is *sēbas*, *sēbas*, "fear," but this primitive meaning is completely merged into "reverence," "hold in awe": "In vain do they worship me" (Mt 15 9, etc). λατρεύω, *latreūō*, is "serve" (religiously), or "worship publicly," "perform sacred services," "offer gifts," "worship God in the observance of the rites instituted for His worship." It is tr<sup>d</sup> "worship" in Acts 7 42; 24 14 AV, but "serve," ARV: "serve the host of heaven," "serve I the God of our fathers"; but both AV and ARV render Phil 3 3, "worship by the Spirit of God," and He 10 2, "the worshippers," the context in the first two being general, in the second two specific. In 2 Tim 1 3 and many other cases both AV and RV give "serve," the meaning not being confined to worship; but of Lk 2 37 RV: "worshipping [AV "served"] with fastings and supplications." Rom 1 25 gives both *sebazōmai* and *latreūō* in their specific meanings: "worshipped [venerated] and served [religiously] the creature." δόξα, *dōxa*, "glory" (Lk 14 10 AV: "Thou shalt have worship," is a survival of an old Eng. use, rightly discarded in RV). θρησκεία, *thrēskēia* (Col 2 18), "a voluntary humility and worshipping of the angels" (ARV m "an act of reverence"), has the root idea of trembling or fear. θεραπεύω, *therapeūō*, "serve," "heal," "tend" (Acts 17 25 AV: "neither is worshipped by men's hands"), is "served" in RV, perhaps properly, but its close connection with "temples made with hands" makes this questionable. νεωκόρος, *neōkōros*, "temple-sweepers," "temple-keeper" (Acts 19 35), has its true meaning in RV, but "worshipper" is needed to complete the idea, in our modern idiom. In the Apoc the usage is the same as in the NT, the vbs. used being, in the order of their frequency, *proskunēō*, *sēbōmai*, *thrēskēō*, and *latreūō*.

The NT idea of worship is a combination of the reverential attitude of mind and body, the general ceremonial and religious service of God, the feeling of awe, veneration, adoration; with the outward and ceremonial aspects approaching, but not reaching, the vanishing point. The total idea of worship, however, both in the OT and NT, must be built up, not from the words specifically so tr<sup>d</sup>, but also, and chiefly, from the whole body of description of worshipful feeling and action, whether of individuals singly and privately, or of larger bodies engaged in the public services of sanctuary, tabernacle, temple, synagogue, upper room or meeting-place.

Space permits no discussion of the universality of worship in some form, ranging from superstitious fear or fetishism to the highest spiritual exercise of which man is capable; nor of the primary motive of worship, whether from a desire to placate, ingratiate, or propitiate some higher power, or to commune and share with him or it, or express instinctive or purposed devotion to him. On the face of the Bible narratives, the instinct of communion, praise, adoring gratitude would seem to be the earliest moving force (cf Gen 4 3.4, Cain, Abel; Rom 1 18-25, the primitive knowledge of God as perverted to creature-worship; Gen 8 20, Noah's altar; and Gen 12 7, Abram's altar). That propitiation was an early element is indicated probably by Abel's offering from the flock, certainly by the whole system of sacrifice. Whatever its origin, worship as developed in the OT is the expression of the religious instinct in penitence, prostration, adoration, and the uplift of holy joy before the Creator.

In detail, OT worship was individual and private, though not necessarily secret, as with Eliezer (Gen 24 26f), the expression of personal gratitude for the success of a mission,

**2. OT Worship** or with Moses (Ex 34 8), seeking God's favor in intercessory prayer; it was sometimes, again, though private, in closest association with others, perhaps with a family significance (Gen 8 20, Noah; Gen 12 7; 22 5, Abraham: "I and the lad will go yonder; and . . . worship"); it was in company with the "great congregation," perhaps partly an individual matter, but gaining blessing and force from the presence of others (Ps 42 4: "I went with the throng . . . keeping holy-day"); and it was, as the national spirit developed,

the expression of the national devotion (1 Ch 29 20: "And all the assembly . . . worshipped Jeh, and the king"). In this public national worship the truly devout Jew took his greatest delight, for in it were inextricably interwoven together, his patriotism, his sense of brotherhood, his feeling of solidarity, his personal pride and his personal piety.

The general public worship, esp. as developed in the Temple services, consisted of: (1) Sacrificial acts, either on extraordinary occasions, as at the dedication of the Temple, etc, when the blood of the offerings flowed in lavish profusion (2 Ch 7 5), or in the regular morning and evening sacrifices, or on the great annual days, like the Day of Atonement. (2) Ceremonial acts and posture of reverence or of adoration, or symbolizing the seeking and receiving of the Divine favor, as when the high priest returned from presenting incense offering in the holy place, and the people received his benediction with bowed heads, reverently standing (2 Ch 7 6), or the worshippers prostrated themselves as the priests sounded the silver trumpets at the conclusion of each section of the Levites' chant. (3) Praise by the official ministrants of the people or both together, the second probably to a very limited extent. This service of praise was either instrumental, silver "trumpets and cymbals and instruments of music," or it might be in vocal song, the chant of the Levites (very likely the congregation took part in some of the antiphonal psalms); or it might be both vocal and instrumental, as in the magnificent dedicatory service of Solomon (2 Ch 5 13), when "the trumpeters and singers were as one, to make one sound to be heard in praising and thanking Jeh." Or it might be simply spoken: "And all the people said, Amen, and praised Jeh" (1 Ch 16 36). How fully and splendidly this musical element of worship was developed among the Hebrews the Book of Ps gives witness, as well as the many notices in Ch (1 Ch 15, 16, 25; 2 Ch 5, 29, 30, etc). It is a pity that our actual knowledge of Heb music should be so limited. (4) Public prayer, such as is described in Dt 26, at the dedication of the Temple (2 Ch 6, etc), or like Pss 60, 79, 80. Shorter forms, half praise, half prayer, formed a part of the service in Christ's time. (5) The annual feasts, with their characteristic ceremonies. See PASSOVER; TABERNACLE, etc. Places of worship are discussed under ALTAR; HIGH PLACE; SANCTUARY; TABERNACLE; TEMPLE, etc.

In the NT we find three sorts of public worship, the temple-worship upon OT lines, the synagogue-worship, and the worship which grew up in the Christian church out of the characteristic life of the new faith.

### 3. NT Worship

The synagogue-worship, developed by and after the exile, largely substituted the book for the symbol, and thought for the sensuous or object appeal; it was also essentially popular, homelike, familiar, escaping from the exclusiveness of the priestly service. It had four principal parts: (1) the recitation of the *shema'*, composed of Dt 6 4-9; 11 13-21, and Nu 15 37-41, and beginning, "Hear [*shema'*], O Israel: Jeh our God is one Jeh"; (2) prayers, possibly following some set form, perhaps repeating some psalm; (3) the reading by male individuals of extracts from the Law and the Prophets selected by the "ruler of the synagogue," in later years following the fixed order of a lectionary, as may have been the case when Jesus "found the place"; (4) the *tarqum* or condensed explanation in the vernacular of the Scriptures read.

It is questioned whether singing formed a part of the service, but, considering the place of music in Jewish religious life, and its subsequent large place in Christian worship, it is hard to think of it as absent from the synagogue.

Public Christian worship necessarily developed along the lines of the synagogue and not the temple, since the whole sacrificial and ceremonial system terminated for Christianity with the life and death of Jesus.

### 4. Public Christian Worship

The perception of this, however, was gradual, as was the break of Jewish Christians with both synagogue and temple. Jesus Himself held the temple in high honor, loved to frequent it as His Father's house, reverently observed the feasts, and exhibited the characteristic attitude of the devout but un-Pharisaic Israelite toward the temple and its worship. Yet by speaking of Himself as "greater than the temple" (Mt 12 6) and by quoting Hos 6 6, "I desire goodness and not sacrifice," He indicated the relative subordinateness of the temple and its whole system of worship, and in His utterance to the woman of Samaria He intimated the abolition both of the whole idea of the central sanctuary and of the entire ceremonial worship: "Neither in this mountain, nor in Jerus, shall ye worship the Father"; "They that worship him must worship in spirit and truth" (Jn 4 21,24). His chief interest in the temple seems to have been as a "house of prayer" and an opportunity to reach and touch the people. We cannot help feeling that with all His love for the holy precincts, He must have turned with relief from the stately, formal, distant ceremonial of the temple, partly relieved though it was by the genuine religious passion of many worshippers, to the freer, more vital, closer heart-worship of the synagogue, loaded though that also was with form, tradition, ritual and error. Here He was a regular and reverent attendant and participant (Mk 1 21,39; 3 1; 6 2; Lk 6 6). Jesus did not Himself prescribe public worship for His disciples, no doubt assuming that instinct and practice, and His own spirit and example, would bring it about spontaneously, but He did seek to guard their worship from the merely outward and spectacular, and laid great emphasis on privacy and real "innerness" in it (Mt 6 1-18, etc). Synagogue-worship was probably not abandoned with Pentecost, but private brotherhood meetings, like that in the upper chamber, and from house to house, were added. The young church could hardly have "grown in favor with the people," if it had completely withdrawn from the popular worship, either in temple or synagogue, although no attendance on the latter is ever mentioned. Possibly the Christians drew themselves together in a synagogue of their own, as did the different nationalities. The reference in Jas: "if there come unto your synagogue" (2 2), while not conclusive, since "synagogue" may have gained a Christian significance by this time, nevertheless, joined with the traditions concerning James's ascetic zeal and popular repute, argues against such a complete separation early. Necessarily with the development into clearness of the Christian ideas, and with the heightening persecution, together with the hard industrial struggle of life, the observance of the Jewish Sabbath in temple or synagogue, and of the Christian's Lord's Day, grew incompatible. Yet the full development of this must have been rather late in Paul's life. Compare his missionary tactics of beginning his work at the synagogue, and his custom of observing as far as possible the Jewish feasts (Acts 20 16; 1 Cor 16 8). Our notions of the worship of the early church must be constructed out of the scattered notices descriptive of different stages in the history, and different churches present different phases of development. The time was clearly the Lord's Day, both by the Jewish churches (Jn 20 19,26) and by the Gr (Acts 20 7; 1 Cor 16 2). The daily meeting of Acts 2 46 was probably not continued, no mention occurring later.

There are no references to yearly Christian festivals, though the wide observance in the sub-apostolic period of the Jewish Passover, with references to the death and resurrection of Jesus, and of Pentecost to commemorate the gift of the Holy Spirit, argues for their early use. The *place* was of course at first in private houses, and the earliest form of Christian church architecture developed from this model rather than the later one of the basilica. 1 Cor gives rather full data for the worship in this free and enthusiastic church. It appears that there were two meetings, a public and a private. The public worship was open, informal and missionary, as well as edificatory. The unconverted, inquirers and others, were expected to be present, and were frequently converted in the meeting (1 Cor 14 24). It resembled much more closely an evangelical "prayer and conference meeting" of today than our own formal church services. There is no mention of official ministrants, though the meeting seems to have been under some loose guidance. Any male member was free to take part as the Spirit might prompt, esp. in the line of his particular "spiritual gift" from God, although one individual might have several, as Paul himself. Largely developed on synagogue lines, but with a freedom and spirit the latter must have greatly lacked, it was composed of: (1) Prayer by several, each followed by the congregational "Amen." (2) Praise, consisting of hymns composed by one or another of the brethren, or coming down from the earlier days of Christian, perhaps Jewish, history, like the *Benedictus*, the *Magnificat*, the *Nunc dimittis*, etc. Portions of these newer hymns seem to be imbedded here and there in the NT, as at Rev 5 9-13: "Worthy art thou," etc (cf Rev 15 3; 11 17, etc); also: "He who was manifested in the flesh, Justified in the spirit, Seen of angels, Preached among the nations, Believed on in the world, Received up in glory" (1 Tim 3 16). Praise also might take the form of individual testimony, not in metrical form (1 Cor 14 16). (3) Reading of the Scripture must have followed, according to the synagogue model. Paul presupposes an acquaintance with the OT Scriptures and the facts of Jesus' life, death, resurrection. Instructions to read certain epp. in the churches indicate the same. (4) Instruction, as in 1 Cor 2 7; 6 5, teaching for edification. (These passages, however, may not have this specific reference.) (5) Prophesying, when men, believed by themselves and by the church to be specially taught by the Holy Spirit, gave utterance to His message. At Corinth these crowded on one another, so that Paul had to command them to speak one at a time. (6) Following this, as some believe, came the "speaking with tongues," perhaps fervent and ejaculatory prayers "so rugged and disjointed that the audience for the most part could not understand" until someone interpreted. The speaking with tongues, however, comprised praise as well as prayer (1 Cor 14 16), and the whole subject is enshrouded in mystery. See TONGUES, GIFT OF. (7) The meeting closed with the benediction and with the "kiss of peace."

The "private service" may have followed the other, but seems more likely to have been in the evening, the other in the morning. The disciples met in one place and ate together a meal of their own providing, the *agápē*, or love feast, symbolizing their union and fellowship, preceded or followed by prayers (*Did.*, x), and perhaps interspersed by hymns. Then followed the "Lord's Supper" itself, according to the directions of the apostle (1 Cor 11 23-28).

How far "Christian worship" was "Christian" in the sense of being directly addressed to Christ, is not easily answered. We must not read into their mental content the fully developed Christology of later centuries, but

it is hard to believe that those who had before them Thomas' adoring exclamation, "My Lord and my God!" the saying of the first martyr, "Lord Jesus, receive my spirit," the dictum of the great apostle, "Who, existing in the form of God," the utterances of He, "And let all the angels of God worship Him," "Thy throne, O God, is forever and forever," and, later, the prologue of Jn, and the ascriptions of praise in the Apocalypse, could have failed to bow down in spirit before Jesus Christ, to make known their requests through Him, and to lift up their adoration in song to Him, as according to Pliny's witness, 112 AD, "they sing a hymn to Christ as God." The absolutely interchangeable way in which Paul, for instance, applies "Lord" in one breath to the Father, to the OT Jeh, and to Jesus Christ (Rom 10 11.13; 14 4.6.8.11.12, etc) clearly indicates that while God the Father was, as He must be, the ultimate and principal object of worship, the heart and thought of God's NT people also rested with adoring love on Him who is "worthy . . . to receive the power and riches and wisdom, and might, and glory, and honor and blessing." The angel of the Apocalypse would not permit the adoration of the seer (Rev 22 9), but Jesus accepts the homage of Thomas, and in the Fourth Gospel declares it the duty of all to "honor the Son, even as they honor the Father" (Jn 5 23).

The classical passages for Christian worship are Jn 4 23.24, culminating in (m): "God is spirit: and they that worship him must worship in spirit and truth," and Phil 3 3, "who worship by the Spirit of God." These define its inner essence, and bar out all ceremonial or deputed worship whatever, except as the former is, what the latter can never be, the genuine and vital expression of inner love and devotion. Anything that really stimulates and expresses the worshipful spirit is so far forth a legitimate aid to worship, but never a substitute for it, and is harmful if it displaces it. Much, perhaps most, stately public worship is as significant to God and man as the clack of a Tibetan prayer-mill. The texts cited also make of worship something far deeper than the human emotion or surrender of will; it is the response of God's Spirit in us to that Spirit in Him, whereby we answer "Abba, Father," deep calling unto deep. Its object is not ingratiating, which is unnecessary, nor propitiation, which has been made "once for all," nor in any way "serving" the God who "needeth not to be worshipped with men's hands" (Acts 17 25), but it is the loving attempt to pay our unpayable debt of love, the expression of devoted hearts, "render[ing] as bullocks the offering of our lips" (Hos 14 2). For detail it is not a physical act or material offering, but an attitude of mind: "The sacrifices of God are a broken spirit"; "sacrifices of praise, with which God is well pleased"; not the service of form in an outward sanctuary, the presentation of slain animals, but the service of love in a life: "Present your bodies a living sacrifice"; not material sacrifices, but spiritual: your rational "service"; not the service about an altar of stone or wood, but about the sanctuary of human life and need; for this is true religion ("service," "worship," *threskeia*), "to visit the fatherless and widows in their affliction"; not the splendor of shining robes or the sounding music of trumpets or organs, but the worshipping glory of holy lives; in real fact, "hallowing Thy name," "and keeping oneself unspotted from the world." The public worship of God in the presence of His people is a necessity of the Christian life, but in spiritual Christianity the ceremonial and outward approaches, if it does not quite reach, the vanishing point.

LITERATURE.—BDB; Thayer's *NT Lexicon* s.v.; arts. on "Praise," "Worship," "Temple," "Church," "Prayer," in *HDB*, *DB*, *New Sch-Herz*, *DCG*; comms. on Pss. Ch. Cor; Weizsäcker, *The Apostolic Age of the Church*, II; Pfeleiderer, *Das Urchristentum* (ET); Leoning, *Gemeindeverfassung des Urchristentums*; Edersehim, *The Temple, Its Ministry and Service, as They Were at the Time of Jesus Christ, and Life and Times of Jesus the Messiah*; Hort, *The Christian Ecclesia*; Lindsay, *Church and the Ministry in the Early Centuries*; McGiffert, *A History of Christianity in the Apostolic Age*.

PHILIP WENDELL CRANNELL  
WORSHIP, IMAGE. See IMAGES.



**WORSHIPPER**, wŭr'ship-ēr. See **TEMPLE KEEPERS**; **WORSHIP**.

**WORTHIES**, wŭr'thiz (אֲדִיר, 'addir, "majestic," "noble" [cf Jgs 5 13, etc]): In Nah 2 5, AV "He shall recount his worthies" (m "gallants"), ERV "He remembereth his worthies," ARV "He remembereth his nobles." As MT stands, the Assy king hurriedly summons his *commanders* to repel the assault, but the passage is obscure and the text quite possibly in need of emendation.

**WOT**. See **WIST**, **WITTY**, **WOT**.

**WRATH**, rath, rôth, rāth (**ANGER**) (אַף, 'aph, from אָנַף, 'ānaph, "to snort," "to be angry"; ὀργή, orgē, θυμός, thumós, ὀργίζομαι, orgizomai): Designates various degrees of feeling, such as sadness (Ps 85 4), a frown or turning away of the face in grief or anger (2 Ch 26 19; Jer 3 12), indignation (Ps 38 3), bitterness (Jgs 18 25), fury (Est 1 12), full of anger (Gen 4 5; Jn 7 23), snorting mad (Gen 27 45; Mt 2 16).

Wrath is used with reference to both God and man. When used of God it is to be understood that there is the complete absence of

**1. Divine Wrath** that caprice and unethical quality so prominent in the anger attributed to the gods of the heathen and to man.

The Divine wrath is to be regarded as the natural expression of the Divine nature, which is absolute holiness, manifesting itself against the wilful, high-handed, deliberate, inexcusable sin and iniquity of mankind. God's wrath is always regarded in the Scripture as the just, proper, and natural expression of His holiness and righteousness which must always, under all circumstances, and at all costs be maintained. It is therefore a righteous indignation and compatible with the holy and righteous nature of God (Nu 11 1-10; Dt 29 27; 2 S 6 7; Isa 5 25; 42 25; Jer 44 6; Ps 79 6). The element of love and compassion is always closely connected with God's anger; if we rightly estimate the Divine anger we must unhesitatingly pronounce it to be but the expression and measure of that love (cf Jer 10 24; Ezk 23; Am 3 2).

Wrath, when used of man, is the exhibition of an enraged sinful nature and is therefore always inexcusable (Gen 4 5,6; 49 7; Prov 19 19;

**2. Human Wrath** Job 5 2; Lk 4 28; 2 Cor 12 10; Gal 5 20; Eph 4 31; Col 3 8). It is for this reason that man is forbidden to allow anger to display itself in his life. He is not to "give place unto wrath" (Rom 12 19 m), nor must he allow "the sun to go down upon his wrath" (Eph 4 26). He must not be angry with his brother (Mt 5 22), but seek agreement with him lest the judgment that will necessarily fall upon the wrathful be meted out to him (Mt 5 25,26). Particularly is the manifestation of an angry spirit prohibited in the training and bringing up of a family (Eph 6 4; Col 3 19). Anger, at all times, is prohibited (Nu 18 5; Ps 37 8; Rom 12 19; Gal 5 19; Eph 4 26; Jas 1 19,20).

Wrath or anger, as pertaining to God, is very much more prominent in the OT than in the NT.

This is to be accounted for probably **3. Divine Wrath Con-** because the NT magnifies the grace and love of God as contrasted with His sistent with wrath; at least love is more prominent than wrath in the revelation and **Love** teaching of Christ and His apostles.

Nevertheless, it must not be thought that the element of wrath, as a quality of the Divine nature, is by any means overlooked in the NT because of the prominent place there given to love. On the

contrary, the wrath of God is intensified because of the more wonderful manifestation of His grace, mercy and love in the gift of His Son Jesus Christ as the Saviour of the world. God is not love only: He is also righteous; yea, "Our God is a consuming fire" (He 12 29); "It is a fearful thing to fall into the hands of the living God" (He 10 31). No effeminate, sentimental view of the Fatherhood of God or of His mercy and loving-kindness can exclude the manifestation of His just, righteous and holy anger against sin and the sinner because of his transgression (1 Pet 1 17; He 10 29). One thing only can save the sinner from the outpouring of God's righteous anger against sin in the day of visitation, namely, faith in the Lord Jesus Christ as the Divinely appointed Redeemer of the world (Jn 3 36; Rom 1 16-18; 5 9). Nor should the sinner think that the postponement or the omission (or seeming omission) of the visitation of God's wrath against sin in the present means the total abolition of it in the future. Postponement is not abolition; indeed, the sinner, who continually rejects Jesus Christ and the salvation which God has provided in Him, is simply 'treasuring up' wrath for himself "in the day of wrath and revelation of the righteous judgment of God; who [one day] will render to every man according to his works: . . . to them that . . . obey not the truth, but obey unrighteousness, . . . wrath and indignation, tribulation and anguish, upon every soul of man that worketh evil" (Rom 2 5-9; 2 Pet 3 10; Rev 6 16,17; 16 19; 19 15). See **RETRIBUTION**, 5.

God's anger while slow, and not easily aroused (Ps 103 8; Isa 48 9; Jon 4 2; Nah 1 3), is to be dreaded (Ps 2 12; 76 7; 90 11; Mt 10 28); is not to be provoked (Jer 7 19; 1 Cor 10 22); when visited, in the present life, should be borne with submission (2 S 24 17; Lam 3 39,43; Mic 7 9); prayer should be earnestly made for deliverance from it (Ps 39 10; 80 4; Dnl 9 16; Hab 3 2); it should be the means of leading man to repentance (Isa 42 24,25; Jer 4 8).

Certain specific things are said esp. to arouse God's anger: continual provocation (Nu 32 14), unbelief (Ps 78 21,22; He 3 18,19), impence (Isa 9 13,14; Rom 2 5), apostasy (He 10 26,27), idolatry (Dt 32 19; 20,22; 2 K 22 17; Jer 44 3), sin in God's people (Ps 59 30-32; Isa 47 6), and it is manifested esp. against opponents of the gospel of Jesus Christ (Ps 2 2,3,5; 1 Thess 2 16).

There is a sense, however, in which anger is the duty of man; he is to "hate evil" (Ps 97 10). It is not enough that God's people should

**4. Righteous and Unrighteous Anger** love righteousness, they must also be angry with sin (not the sinner). A man who is incapable of being angry at sin is at the same time thereby adjudged to be incapable of having a real love for righteousness. So there is a sense in which a man may be said to "be . . . angry, and sin not" (Eph 4 26). Anger at the sin and unrighteousness of men, and because their sin is grievous to God, may be called a "righteous indignation." Such an indignation is attributed to Jesus when it is said that He "looked round about on them with anger, being grieved at the hardening of their heart" (Mk 3 5). When anger arises because of this condition, it is sinless, but when anger arises because of wounded or aggrieved personality or feelings, it is sinful and punishable. Anger, while very likely to become sinful, is not really sinful in itself.

We have illustrations in the Scriptures of wrath or anger that is *justifiable*: Jesus (Mk 3 5), Jacob (Gen 31 36), Moses (Ex 11 8; 32 19; Lev 10 16; Nu 16 15), Nehemiah (Neh 5 6; 13 17,25); of *sinful anger*: Cain (Gen 4 5,6), Esau (Gen 27 45), Moses (Nu 20 10,11), Balaam (Nu 22 27), Saul (1 S 20 30), Ahab (1 K 21 4), Naaman (2 K 5 11), Herod (Mt 2 16), the Jews (Lk 4 28), the high priest (Acts 5 17; 7 54).

WILLIAM EVANS

**WREST**, rest: Found in AV and RV 3 t in the writings of Moses, viz. Ex 23 2,6; Dt 16 19. In

all three places it refers to twisting, or turning aside, or perverting judgment or justice. In Dt 24 17 RV has "wrest," where AV has "pervert."

In Ps 56 5 (צָבַב, 'āḥab); 2 Pet 3 16 (στρεβλόω, streblōō), it refers to the word or words of God in the Scriptures. In the Pss the servant of God, who speaks in God's name, complains that the enemies "wrest," misinterpret, misapply and pervert his words. In Pet it is the ignorant and unstedfast who so pervert and misuse some of the difficult words of Paul, and they do it to their own destruction—a most earnest warning against carelessness and conscienceless indifference in interpreting Scripture.

G. H. GERBERDING

**WRESTLING**, res'ling (רָבַח, 'ābhak; πάλη, pālē). See GAMES II, 3, (i); JACOB; NAPHTALI.

**WRINKLE**, rin'k'l (רִמְמָה, kāmāh, "to lay hold on"; ρυτίς, rūtis, "a wrinkle"): In Job 16 8, RV substitutes, "Thou hast laid fast hold on me" (m "shrivelled me up") for AV "Thou hast filled me with wrinkles." In Eph 5 27, St. Paul's figurative reference to the church as a bride, "not having spot or wrinkle," is indicative of the perennial youth and attractiveness of the church.

**WRITING**, rit'ing:

- I. GENERAL
  - 1. Definition
  - 2. Inward Writing
  - 3. Outward Writing
- II. THE SYMBOLS
  - 1. Object Writing
  - 2. Image Writing
  - 3. Picture Writing
  - 4. Mnemonic Writing
  - 5. Phonetic Writing
- III. METHODS
- IV. INSTRUMENTS
- V. MATERIALS
  - 1. Clay
  - 2. Stone
  - 3. Lead
  - 4. Bronze
  - 5. Gold and Silver
  - 6. Wood
  - 7. Bones and Silver
  - 8. Vellum
  - 9. Papyrus
  - 10. Paper
  - 11. Ink
- VI. FORMS
  - 1. The Roll
  - 2. The Codex
- VII. WRITING
  - 1. Writers
  - 2. The Writing Art
- VIII. HISTORY
  - 1. Mythological Origins
  - 2. Earliest Use
  - 3. Biblical History

LITERATURE

**I. General.**—Writing is the art of recording thought, and recording is the making of permanent symbols. Concept, expression and

**1. Definition**—record are three states of the same work or word. Earliest mankind expressed itself by gesture or voice and recorded in memory, but at a very early stage man began to feel the need of objective aids to memory and the need of transmitting a message to a distance or of leaving such a message for the use of others when he should be away or dead. For these purposes, in the course of time, he has invented many symbols, made in various ways, out of every imaginable material. These symbols, fixed in some substance, inward or outward, are *writing* as distinguished from oral speech, gesture language, or other unrecording forms of expression. In the widest sense writing thus includes, not only penmanship or chirography, but epigraphy, typography, phonography, photography, cinematography, and many other kinds of writing as well as mnemonic object writing and inward writing.

Writing has to do primarily with the symbols, but as these symbols cannot exist without being in some substance, and as they are often modified as to their form by the materials of which they are made or the instruments used in making, the history of writing has to do, not only with the signs, symbols or characters themselves, but with the material out of which they are made and the instruments and methods by which they are made.

The fact that memory is a real record is well known in modern psychology, which talks much of inward speech and inward writing.

**2. Inward Writing** By inward writing is commonly meant the inward image or counterpart of visual or tangible handwriting as distinguished from the inward records of the sound of words, but the term fairly belongs to all inward word records. Of these permanent records two chief classes may be distinguished: sense records, whether the sense impression was by eye, ear, finger-tip or muscle, and motor records or images formed in the mind with reference to the motion of the hand or other organs of expression. Both sense records and motor records include the counterparts of every imaginable kind of outward handwriting.

We meet this inward writing in the Bible in the writing upon the tablets of the heart (Prov 3 3; 7 3; Jer 17 1; 2 Cor 3 3), which is thus not a mere figure of speech but a proper description of that effort to fix in memory which some effect by means of sound symbols and some by the sight symbols of ordinary handwriting.

It has also its interesting and important bearing on questions of inspiration and revelation where the prophet "hears" a voice (Ex 19 19; Nu 7 89; Rev 19 1.2) or "sees" a vision (2 K 6 17; Isa 6; Am 7 1-9) or even sees handwriting (Rev 17 5). This handwriting not only seems "real" but is real, whether caused by external sound or vision or internal human or superhuman action.

Outward writing includes many kinds of symbols produced in various ways in many kinds of material.

**3. Outward Writing** The commonest kind is alphabetical handwriting with pen and ink on paper, but alphabetic symbols are not the only symbols, the hand is not the only means of producing symbols, the pen is not the only instrument, and ink and paper are far from being the only materials.

The ordinary ways of human expression are voice and gesture. Corresponding to these there is an oral writing and a gesture writing. For the recording of vocal sounds various methods have been invented: direct carving or molding in wax or other material, or translating into light vibrations and recording these by photograph or kymograph. Both phonographic and photographic records of sounds are strictly oral writing.

The record of gestures by making pictures of them forms a large fraction of primitive picture writing (e.g. the picture of a man with weapon poised to throw) and the modern cinematography of pantomime is simply a perfected form of this primitive picture writing.

Handwriting is simply hand gesture with a mechanical device for leaving a permanent record of its motion by a trail of ink or incision. In the evolution of expression the imitation of human action tends to reduce itself to sign language, where both arms and the whole body are used, and then to more and more conventionalized hand gesture. This hand gesture, refined, condensed and adapted to mechanical conditions, and provided with pencil, chisel, or pen and ink, is handwriting. Its nature is precisely analogous to that of the self-registering thermometer or kymograph.

Nearly all the great body of existing written documents, save for the relatively few modern phonographic, kymographic and other visible speech records, is handwritten, the symbols being produced, selected, arranged, or at least pointed out, by the hand. Even the so-called phonetic writing, as usually understood, is not sound record but consists of hand-gesture symbols for sounds.

**II. The Symbols.**—Among the many kinds of outward signs used in writing the best known are the so-called Phoen alphabet and its many derivatives, including the usual modern alphabets. Other well-known varieties are the wedge system of Assyria and Babylonia, the hieroglyphic systems of Egypt and Mexico, the Chinese characters, stenographic systems, the Morse code, the Braille system, the abacus, the notched stick, the knotted cord, wampum and twig bundles. These, however, by no means exhaust the list of signs which have been used for record or message purposes; e.g. colored flags for signaling, pebbles, cairns, pillars, flowers, trees, fishes, insects, animals and parts of animals, human beings, and images of all these things, have all served as record symbols in writing.

The various symbols may be grouped as objects and images, each of these classes divided again into pictorial or representative signs and mnemonic or conventional signs, mnemonic signs again divided into ideographic and phonetic, and phonetic again into verbal, syllabic (consonantal), and alphabetic. This may be represented graphically as follows:

- (A) OBJECTS  
 (1) Pictorial  
 (2) Conventional (Mnemonic)  
 (a) Ideographic (Eye Images)  
 (b) Phonetic (Ear Images)  
 (α) Verbal  
 (β) Syllabic  
 (γ) (Consonantal)  
 (δ) Alphabetic
- (B) IMAGES  
 (1) Pictorial  
 (2) Conventional (Mnemonic)  
 (a) Ideographic  
 (b) Phonetic  
 (α) Verbal  
 (β) Syllabic  
 (γ) (Consonantal)  
 (δ) Alphabetic

Objects may be whole objects (a man) or characteristic parts (human head, arm, leg) or samples (feather or piece of fur). The objects may be natural objects or artificial objects designed for another purpose (arrow), or objects designed esp. to be used as writing symbols (colored flags). Images include images of all these objects and any imaginary images which may have been invented for writing purposes.

Pictorial or representative signs are distinguished from mnemonic or conventional signs by the fact that in themselves they suggest the thing meant, while the others require agreement beforehand as to what they shall mean. The fact, however, that the symbol is a picture of something does not make it pictorial or the writing picture writing. It is pictorial, not because it is a picture, but because it pictures something. The fact, e.g., that a certain symbol may be recognized as an ox does not make of this a pictograph. If it stands for or means an ox, it is a pictograph; if it stands for "divinity," it may be called an ideograph, or if it stands for the letter *a* it is phonetic, a phonogram.

The key to the evolution of writing symbols is to be found in a law of economy. Object writing undoubtedly came first, but man early learned that the image of an object would serve as well for record purposes and was much more convenient to handle. True picture writing followed. The same law of economy led to each of the other steps from pictorial to alphabetic, and may be traced in the history of each kind and part. Every alphabet exhibits it. The history of writing is in brief a history of shorthand. It begins with the whole object or image, passes to the characteristic part, reduces this to the fewest possible strokes which retain likeness, conventionalizes these strokes, and then, giving up all pretense of likeness to the original symbol, and frankly mnemonic, it continues the process of abbreviation until the whole ox has become the letter "a" or perhaps a single dot in some system of stenography.

Object writing is not common in the phonetic stage, but even this is found, e.g., in alphabetical flags for

ship signaling. The actual historical evolution of writing seems to have been object, image-picture, ideogram, phonogram, syllabic, consonant, letter. All of these stages have some echoes at least in the Bible, although even the syllabic stage seems to have been already passed at the time of Moses. The Heb OT as a whole stands for the consonantal stage and the Gr NT for the complete alphabetic—still the climax of handwriting, unless the evolution of mathematical symbols, which is a very elaborate evolution of ideographic handwriting, is so regarded.

Although probably not even a single sentence of the Heb Bible was written in ideographic, picture, or object handwriting, many documents which are used or quoted by Bib. writers were written by these methods, and all of them are repeatedly implied. In a number of cases full exegesis requires a knowledge of their nature and history. A certain number of scholars now believe that the Pent was originally written in cuneiform, after the analogy of the circumstances shown by the Am Tab. In this case of course there would still be traces both of the syllabic and ideographic, but the theory is improbable.

The most primitive writing was naturally pictorial object writing. When the hunter first brought

home his quarry, this had in it most of the essential elements of modern handwriting. Those who remained at home read in the actual bodies the most essential record of the trip. When, further, the hunter brought back useless quarry to evidence his tale of prowess, the whole essence of handwriting was involved. This was whole-object record, but object abbreviations soon followed. Man early learned that skins represented whole animals (the determinative for "quadruped" in Egypt is a hide), and that a reindeer's head or antlers, or any characteristic part, served the simple purpose of record just as well as the whole object, and this method of record survives in a modern hunting-lodge. The bounty on wolves' scalps and the expression "so many head of cattle" are similar survivals. In war, men returning hung the dead bodies of their enemies from the prows of their triumphal ships or from the walls of the city, and, in peace, from the gibbet, as object lessons. They soon learned, however, that a head would serve all practical purposes as well as a whole body, and the inhabitants of Borneo today practise their discovery. Then they discovered that a scalp was just as characteristic and more portable, and the scalp belt of the American Indian is the result. The ancient Egyptians counted the dead by "hands" carried away as trophies. Both objects and images tend thus to pass from the whole object to a characteristic part, then to the smallest characteristic part: from the tiger's carcass or stuffed tiger to the tiger's claw or its picture. The next or mnemonic step was taken when the simplest characteristic part was exchanged for a pebble, a twig, a notched stick, a knot, or any other object or image of an object which does not in itself suggest a tiger.

The pictorial object writing had an evolution of its own and reached a certain degree of complexity in elaborate personal adornment, in sympathetic magic, the medicine bag, the prayer stick, pillars, meteoric stones, etc., for worship, collections of liturgical objects, fetishes, votive offerings, trophies, etc.

It reached a still higher order of complexity when it passed into the mnemonic stage represented by the abacus, the knotted cord, the notched stick, the wampum, etc. The knotted cord may be recognized in the earliest hieroglyphic signs, is found still among primitive people, and its most famous example is the Peruvian quipu. It still survives in the cardinal's hat and the custom of knotting a handkerchief for mnemonic purposes. It is found in the Bible in a peculiarly clear statement in the

mnemonic "fringes" of Nu 15 37-41 (cf Dt 22 12). The notched stick is equally old, as seen in the Australian message stick, and its best-known modern example is the tally of the British Exchequer. The abacus and the rosary are practically the lineal descendants of the pebble heap which has a con-

step may perhaps be seen in the account of the leopard-tooth necklace of an African chief described by Frobenius. In itself this was merely a complex trophy record—the tribal record of leopards slain. When, however, the chief took for his own necklace the actual trophy which some members of the tribe

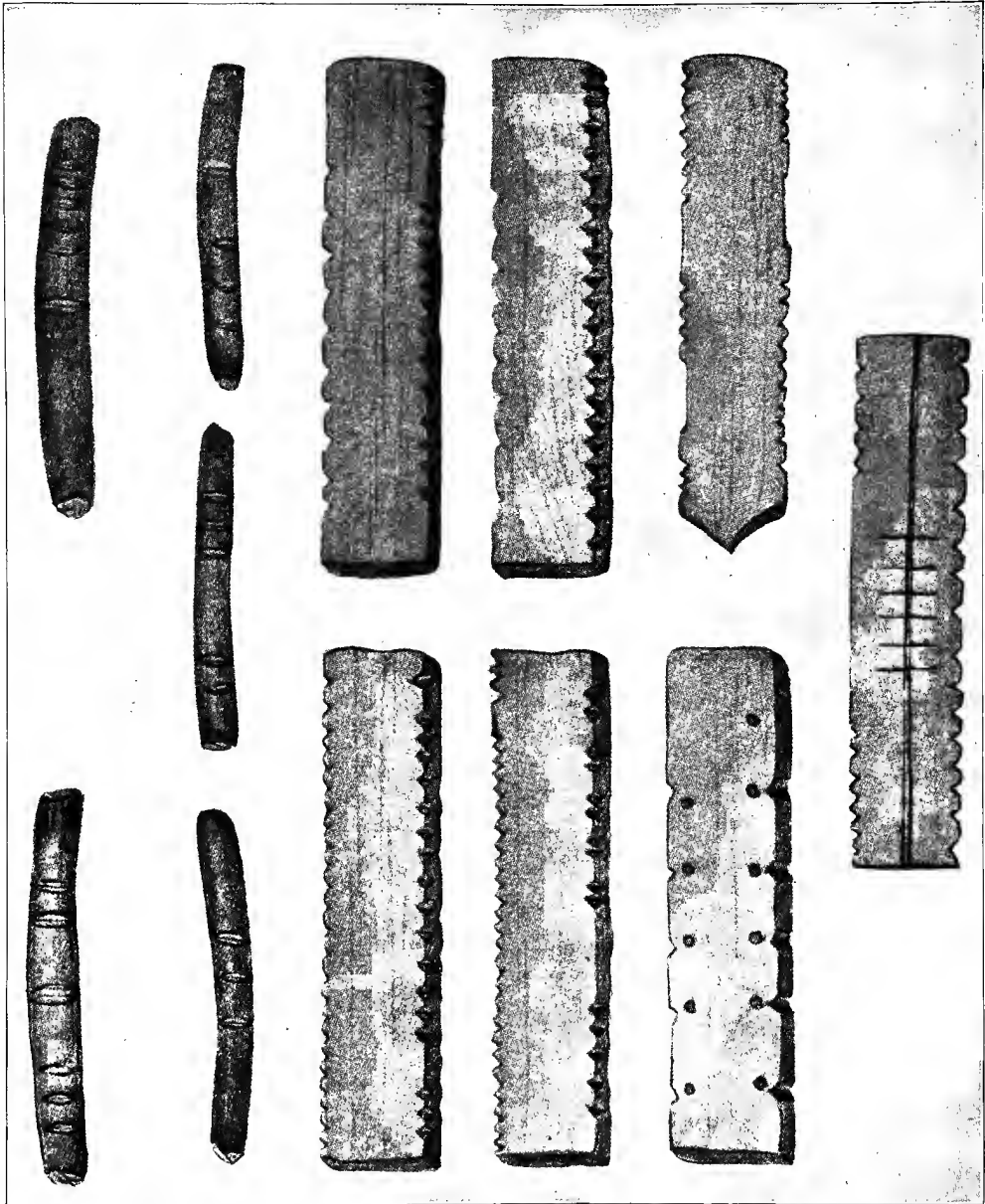

MESSAGE STICKS.

crete modern counterpart in the counting with pebbles by Italian shepherd boys. It is possible that the notched message stick has its echo in Jgs 5 14 (military scribe's staff); Nu 17 1-10 (Aaron's inscribed rod), and all scepters (rods of authority) and herald's wands.

It was a very long step in the history of handwriting from object to image, from the trophy record to the trophy image record. The nature of this

had won, while the hunter made a wooden model of the tooth which served him as trophy, this facsimile tooth became an image record. This

## 2. Image Writing

same step from object to image is most familiar in the history of votive offerings, where the model is substituted for the object, the miniature model for the model, and finally a simple written inscription takes the place of the model. It is seen again in sympathetic

magic when little wax or clay images are vicariously buried or drowned, standing for the person to be injured, and taking the place of sample parts, such as the lock of hair or nail-parings, etc., which are used in like manner by still more primitive peoples.



The Quipu.

It was another long step in the evolution of symbols when it occurred to man that objects worn for record could be represented by paint

**3. Picture Writing** upon the body. The origin of written characters is often sought in the practice of tattooing, but whatever truth

there may be in this must be carried back one step, for it is generally agreed and must naturally have been the fact that body painting preceded tattooing, which is a device for making the record permanent. The transition from the object trophy to the image on the skin might easily have come from the object causing a pressure mark on the skin. There is good reason to believe that the wearing of trophies was the first use of record keeping.

It is of course not proved that body ornaments or body marks are the original of image writing or that trophies are the earliest writing, nor yet that models of trophies or votive offerings were the first step in image writing. It may be that the first images were natural objects recognized as resembling other objects. The Zuni Indians used for their chief fetishes natural rock forms. The first step may have been some slight modification of natural stone forms into greater resemblance, such as is suggested by the slightly modified sculptures of the French-Spanish caves. Or again the tracks of animals in clay may have suggested the artificial production of these tracks or other marks, and the development of pottery and pottery marks may have been the main line of evolution. The Chinese trace the origin of their symbols to bird tracks. Or again smear marks of earth or firebrand or blood may have suggested marks on stone, and the marked pebbles of the Pyrenean caves may have reference to this. Or yet again the marks on the animals in the Pyrenean caves may have been ownership marks and point back to a branding of marks or a primitive tattooing by scarification.

Whatever the exact point or motive for the image record may have been, and however the transition was made, the idea once established had an extensive development which is best illustrated by the picture writing of the American Indians, though perhaps to be found in the Bushmen drawings, petroglyphs, and picture writing the world over. It is almost historic in the Sumerian and the Egyptian, whose phonetic symbols are pictographic in origin at least and whose determinatives are true pictographs.

The transition from pictorial to conventional or mnemonic takes place when the sign ceases to suggest the meaning directly, even after

**4. Mnemon-explanation.** This happens in two ways: (1) when an object or image

stands for something not directly related to that naturally suggested, e.g., when a stuffed fox stands for a certain man because it is his totem, or an ox's head stands for divinity or for the sound "a," or when the picture of a goose stands

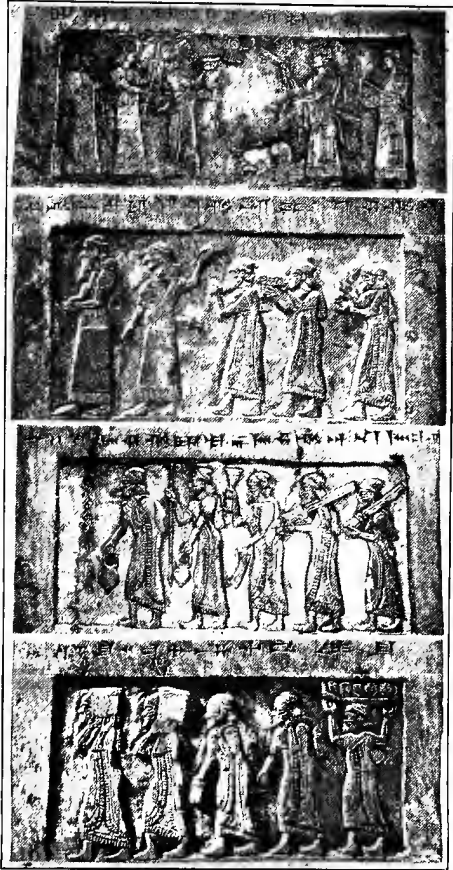

Jewish Mnemonic Fringes, 9th Century BC.

for "son" in the Egypt because the sounds of the two words are the same; (2) when by the natural process of shorthanding the object or image has been reduced beyond the point of recognition. Historically the letter *a* is ox (or goat?); actually it means a certain sound.

When this unrecognizable or conventional sign is intended to suggest a visual image it is called an ideogram, when an ear picture, a phonogram. Anybody looking casually over a lot of Egypt hieroglyphics can pick out kings' names because of the oval line or cartouche in which they are inclosed.

This cartouche is ideographic. On the other hand the pictures of a sun, two chicks, and a cerastes within the cartouche have nothing to do with any of these objects, but stand for the sounds *kufu*—who is the person commonly known as Cheops. This is phonetic.

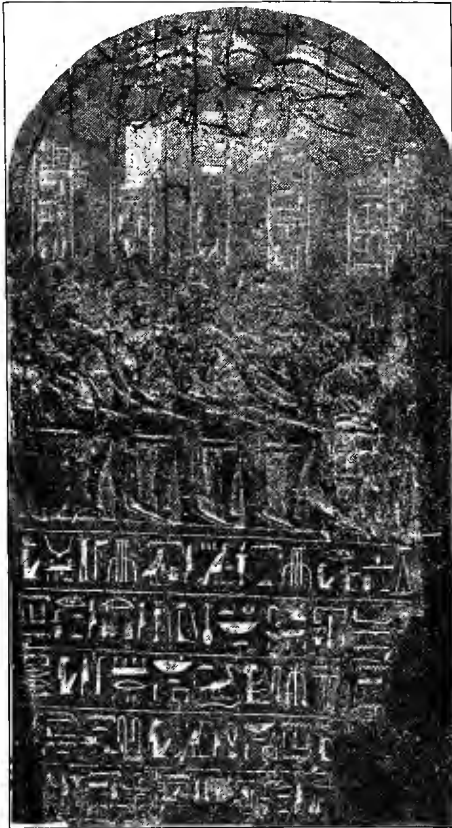

Hieroglyphic Writing.  
(Berlin Museum 832.)

Both old Bab and Egyp show signs of picture origin, but the earliest Bab is mainly ideographic, and both developed soon into the mixed stage of phonetic writing with determinatives.

Phonetic writing seems to have developed out of the fact that in all languages the same sound often has many different meanings.

**5. Phonetic Eng.** "goose" may mean the fowl or the tailor's goose. In Egyp the sound *sa* or *s*, with a smooth breathing, means "goose" or "son," and the picture of a goose means either.

Whether the word-sign is an ideogram or a phonogram is a matter of psychology. Many modern readers even glimpse a word as a whole and jump to the visual image without thinking of sounds at all. To them it is an ideogram. Others, however, have to spell out the sounds, even moving their lips to correspond. To them as to the writer it is a phonogram. The same was true of the ancient picture or ideographic sign. The word-sign was ideogram or phonogram according to intention or to perception.

With the transition to syllabic writing, record became chiefly phonetic. The transition was made apparently by an entirely natural evolution from the practice of using the same word-sign for several different objects having the same sound, and it pro-

ceeded by the way of rebus, as shown in Mexican and Egyp hieroglyphics.

Syllabic writing implies a symbol for every monosyllable. It was a great step therefore when it was discovered that the number of sounds was small and could be represented by individual symbols, as compound words could by syllable signs. At first only consonants were written. In the Sem languages vowels were at first not written at all—possibly they were not even recognized, and one might use any vowel with a particular combination of consonants. However that may be, what many prefer to call consonantal writing seems to have existed for 2,000 years before the vowels were recognized and regularly introduced into the Phoen alphabet. It is at this stage that alphabetic writing, as usually reckoned, began. See ALPHABET.

Phonetic consonantal writing has now been in use some 5,000 years and strict alphabetic writing some 3,000 years, almost to the exclusion of other forms. The characters in use today in several hundred alphabets are probably the historical descendants, with accumulation of slight changes through environment, of characters existing from near the beginning.

Alongside the development of the historic system of symbols, there has been, still within the field of alphabetic writing for the most part, a parallel line with multitudes of shorthand and cryptographic systems. An equally great multitude of code systems are in effect phonetic words or sentences and cryptographically or otherwise used for cable or telegraph, diplomatic letters, criminal correspondence and other secret purposes.

**III. Methods.**—Roughly speaking, the ways of making symbols, apart from the selection of the ready-made, may be reduced to two which correspond to art in the round or in three dimensions

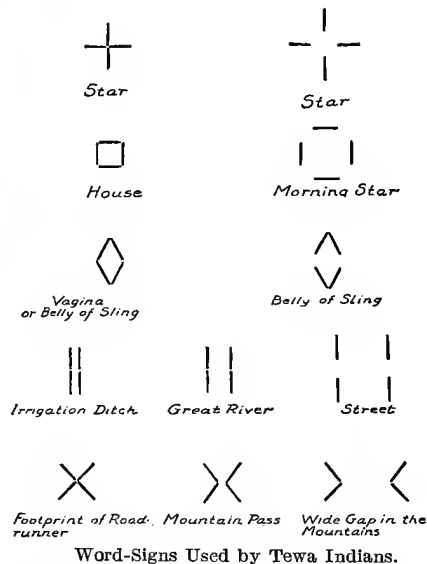

and art in the flat or in two dimensions. The former appeals to eye or touch, affording a contrast by elevation or depression, while the latter produces the same effect by contrasting colors on a flat surface.

Written symbols in three dimensions are produced either by cutting or by pressure. In the case of hard material superfluous matter is removed by sculpture, engraving or die cutting. In the case of plastic or malleable material, it is modeled, molded, hammered or stamped into the required form. To the first form belongs the bulk of stone inscriptions, ancient metal inscriptions, scratched

graffiti, wax tablets, etc. to the later clay tablets, votive figurines, seal impressions, hammered inscriptions, minted coins, also molded inscriptions, coins and medals, etc. Several of the Heb and Gr words for writing imply cutting (*hākaḥ*, *hārat*, *hāraḥ*, etc.; *grāphō*).

Symbols in two dimensions are produced either by drawing or printing, both of which methods consist in the applying of some soft or liquid material to a material of a contrasting color or cutting from thin material and laying on. Drawing applies the material in a continuous or interrupted line of paint, charcoal, colored chalk, graphite, ink or other material. Its characteristic product is the manuscript. This laying on is implied, as some think (Blau, 151), in the commonest Heb word for writing (*kāthabh*). Tattooing (Dt 14 1; Lev 19 28, etc), embroidery (embroidered symbolic figures, Ex 28 33,34) and weaving belong in this class (embroidered words in Pal Talm 20a, qt. Blau, 165).

Printing consists in laying the contrasting color on by means of stencil or pressure, forming symbols in two dimensions at one stroke. Perhaps the most primitive form of printing is that of the pintadoes, by which the savage impresses war paint or other ceremonial forms on his face and body. Branding also belongs in this class (Gal 6 17, figuratively; 3 Macc 2 19; branding on the forehead, CH, § 127; branding a slave, CH, §§ 226, 227).

These processes of cutting, molding, drawing and printing roughly correspond with inscriptions, coins, medals, seals, manuscripts, and printed documents—epigraphy, numismatics, sigillography, chirography, typography.

**IV. Instruments.**—The commonest instruments of ancient writing were the pen, brush and style. Other instruments are: the various tools for modeling, molds, stencils, dies, stamps, needles, engraving tools, compass, instruments for erasure, for the ruling of lines, vessels for ink or water, etc. Several of these are mentioned and others are implied in the Bible. The chisel which cuts and the stylus which scratches are both called *stylus* or simply the "iron" (the iron pen). The graving tool of Ex 32 4, the iron pen of Job 19 24, the pen of Isa 8 1, the pen of iron of Jer 17 1, and, with less reason, the pencil of Isa 44 13, are all commonly interpreted as *stylus* or style, but they are sometimes at least cutting rather than scratching tools. References to wooden tablets also imply the style, and references to clay tablets either the style proper or a similar instrument for pressure marks. The point of a diamond in Jer 17 1, whether it is joined with the pen of iron or not, seems to refer to the use of corundum in the engraving of precious stones. The passages which refer to blotting out (see below) or writing on papyrus (see below) or refer to an ink-horn or ink (see respective articles) imply a *pen* or *brush* rather than style, and presumably the writing of the NT implied in general a reed pen. The wide house "painted with vermilion" (Jer 22 14) implies the brush, but there is no direct evidence of its use in writing in the Bible itself. The existing ostraca from Ahab's palace are, however, done with the brush. The pencil (*sereḥ*) mentioned in Isa 44 13 certainly means some instrument for shaping, but is variously tr<sup>d</sup> as "line" (AV), "red ochre" (RVm), and even "stylus," or "line-marking stylus" (*paragraphis* Aq.). The compass, often referred to in classical times, is found in Isa 44 13. The line ruler (*paragraphis*), referred to by Aquila (Isa 44 13), and the simple plummet as well were probably used, as in later times, for marking lines. The needle is referred to in late Heb and needlework in the Bible (see III, above). The ink-horn or water vessel for moistening the dry inks is implied in all papyrus or leather writing (see INK, INK-HORN).

The Heb term tr<sup>d</sup> "weight of lead" in Zec 5 8, and "talent of lead" is precisely equivalent to the Gr term for the circular plate of lead (*kuklomōtib-dos*) used for ruling lines, but something heavier than the ruling lead seems meant.

Erasure or blotting out is called for in Nu 5 23,



Modern Egyptian Writing Materials.

and often figuratively (Ex 32 32,33; Rev 3 5, etc). If writing was on papyrus, this would call for the sponge rather than the penknife as an eraser, but the latter, which is used for erasure or for making reed pens, is referred to in Jer 36 23. For erasing waxed surfaces the blunt end of the style was used certainly as early as the NT times. Systematic erasure when vellum was scarce produced the palimpsest.

**V. Materials.**—The materials used in writing include almost every imaginable substance, mineral, vegetable, and animal: gold, silver, copper, bronze, clay, marble, granite, precious gems, leaves, bark, wooden planks, many vegetable complexes, antlers, shoulder-blades, and all sorts of bones of animals, and esp. skins. The commonest are stone, clay, metal, papyrus, paper, and leather, including vellum, and all of these except paper are mentioned in the Bible. Paper too must be reckoned with in textual criticism, and it was its invention which, perhaps more even than the discovery of printing with movable type, made possible the enormous multiplication of copies of the Bible in recent times.

Whatever may be the fact as to the first material used for record purposes, the earliest actual records now existing in large quantities are chiefly on clay or stone, and, on the whole, clay records seem to antedate and surpass in quantity stone inscriptions for the earliest historical period. After making all allowances for differences in dating and accepting latest dates, there is an immense quantity of clay records written before 2500 BC and still existing. About 1400 or 1500 BC the clay tablet was in common use from Crete to the extreme East and all over Pal, everywhere, in short, but Egypt, and it seems perhaps to have been the material for foreign diplomatic communications, even in Egypt. Hundreds of thousands of these tablets have been dug up, and undoubtedly millions are in existence, dug or undug. These are chiefly of Mesopotamia. The most famous of these tablets were for a long time of the later period from the library of Ashurbanipal at Nineveh. See LIBRARY OF NINEVEH. Recently, however, those from Tell el-Amarna in Egypt, Boghaz-keui in the Hittite country, and a few from Pal itself vie with these in interest. Most of these tablets are written on both sides and in columns ruled in lines. They measure from an inch to a foot and a half in length and are about two-thirds as wide as they are long. Many of these tablets, the so-called "case tablets," are surrounded with another layer of clay with a docketing inscription. See TABLETS. Other clay forms are the potsherd-

ostraca, now being dug up in considerable quantities in Pal. Ezekiel (4 1) and perhaps Jeremiah (17 13) refer to this material. See OSTRACA.

Stones were used for record before image writing was invented—as cairns, pillars, pebbles, etc.

Many of the early and primitive image records are on the walls of caves or on cliffs (Bushmen, American Indians, etc). Sometimes these are sculptured, sometimes

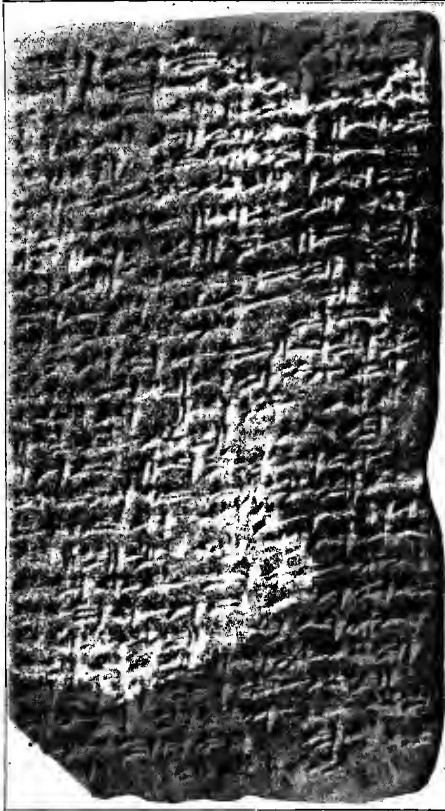

Letter from the Governor of Jerusalem about 1375 BC.

made by charcoal, paint, etc. The durability rather than the more extensive use of stone makes of these documents the richest source for our knowledge of ancient times. Besides natural stone objects, stone pillars, obelisks, statues, etc, stone-wall tablets, the sides of houses and other large or fixed surfaces, there are portable stone-chip ostraca and prepared tablets (tablets of stone, Ex 24 12; 31 18). These latter might be written on both sides (Ex 32 15). Job seems to refer to stone inscriptions (19 24). The famous trilingual inscription of Behistun which gave Rawlinson the key to the Assyrian was on a cliff and refers to King Darius (Rawlinson, *Life*, 58 ff, 142 ff). Two of the most famous of stone inscriptions are the Rosetta Stone, which gave the key to the Eyp hieroglyphics, and the Moabite Stone (W. H. Bennett, *Moabite Stone*, London, 1911), and both have some bearing on Jewish history. An esp. interesting and suggestive stone inscription is the Annals of Thutmose III of Egypt, about 1500 BC, inscribed on the walls of the temple at Karnak. This gives a long account of campaigns in Syria and Pal (Breasted, *Ancient Records of Egypt*, 163-217). The Siloam Inscription, and in general all the recently discovered in-

scriptions of Pal, have their more or less important bearings on Bib. history (Lidzbarski, *Handb.* and *Ephem.*). Moses provided (Dt 27 2-8) for writing the Law on stone (or plaster), and Joshua executed the work (Josh 8 21.32).

Another form of record on stone is the engraving of gems, which is referred to in Ex 28 9.11.21; 39 6.14, etc, and possibly Zec 3 9.

One of the commonest materials, on account of the ease of engraving, probably, is lead. Used more

or less for inscriptions proper, it is also used for diplomatic records and even

literary works. It was very commonly used for charms in all nations, and is referred to in Job (19 24), where it perhaps more likely means a rock inscription filled with lead, rather than actual leaden tablets. For the text of Ps 80 on lead see Gardthausen, p. 26. Submergence curses were usually of lead, but that of Jer 51 62 seems to have been of papyrus or paper (cf W. S. Fox in *Am. Jour. of Phil.*, XXXIII, 1912, 303-4).

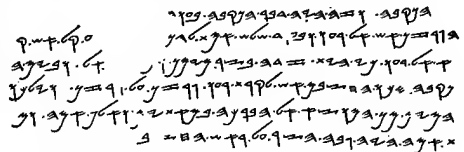

Siloam Inscription. Writing at Jerusalem at the Time of Hezekiah.

Bronze was used for several centuries BC, at least for inscribed votive offerings, for public records set up in the treasuries of the temples and

4. **Bronze** for portable tablets such as the military diplomas. In the time of the Maccabees public records were engraved on such tablets and set up in the temple at Jerus (1 Macc 14 27). There were doubtless many such at the time when Jesus Christ taught there.

Gold and silver as writing material are most commonly and characteristically used in coins and medals. References to money, mostly

5. **Gold and silver money**, are numerous in the OT, **Silver** but these are not certainly coins with alphabetic inscriptions. In NT times

coins were so inscribed, and in one case at least the writing upon it is referred to—"Whose is this image and superscription?" (Mt 22 20). The actual inscription and the actual form of its letters are known from extant specimens of the denarius of the period. See MONEY.

The use of the precious metals for ordinary inscriptional purposes was, however, frequent in antiquity, and the fact that rather few such inscriptions have survived is probably due to the value of the metal for other purposes. The Hittite treaty of Khetasar or Hattusil engraved on silver and sent to the king of Egypt, has long been known from the Eyp monuments (tr in Breasted, *Ancient Records of Egypt*, III, 165-74), and recently fragments of the Hittite version of this treaty have been discovered at Boghaz-keui (Winckler, *MDOG*, XXXV, 12 ff). This has very close relations to Bib. history, whether it was made before or after the Exodus. The famous Orphic gold tablets (Harrison, "Orphic Tablets," in *Prolegomena to the Study of Gr Religion*, 573-600, 660-74) have a bearing on a comparative study of Bib. doctrine. Direct reference to engraving on gold is found in the account of the inscription on the high priest's miter (Ex 28 36). Writing on the horns of the altar is referred to in Jer 17 1, and these horns too were of gold (Ex 30 3). Queen Helena of Adiabene is said to have presented an inscribed gold tablet to the temple at Jerus (Blau, 67). The golden shrines of Ptolemy V



—with their inscribed golden phylacteries—are mentioned on the Rosetta Stone.

Silver, and more esp. gold, have also been very extensively used for the laying on of contrasting colors, either furnishing the background or more often the material laid on. The history of chrysography is a long and full one (Gardthausen, I, 214-17; Blau, 13, 159-63). The standard copy of the OT at Jerus, which was loaned to Alexandria, was apparently in gold letters (Jos, *Ant.* XII, ii, 10) (see SEPTUAGINT), and many of the famous Bib. MSS of the Middle Ages were written wholly or in part with gold, either laid on as gold leaf or dissolved and used as an ink or paint (Gardthausen, 216).

Leaves of trees were early used for charms and writing. Some of the representations of writing on the Egypt monuments show the goddess of writing inscribing the leaves of growing trees. Jewish tradition (*Tōsephā' Giṭṭin* 2 3-5; *Mish Giṭṭin* 2 3, etc, qt. Blau, 16) names many kinds of leaves on which a bill of divorcement (Dt 24 1.3) might or might not be written. Reference to the use of leaves is found in early Gr, Lat and Arab. sources—and they are still used in the East.

Bark also has often been used: both *liber* in Lat and "book" in Eng., according to some, are thought to refer to the bark of the lime or beech tree, and birch bark was a common writing material among the American Indians. It is in the form of wrought wood, staves, planks or tablets, however, that wood was chiefly known in historical times. These wood tablets were used in all early periods and among all nations, esp. for memorandum accounts and children's exercises. Sometimes the writing was directly on the wood, and sometimes on wood coated with wax or with chalk. See TABLETS. Writing on staves is referred to in Nu 17 2. Mk 15 26 seems perhaps to imply that the "superscription" of the cross was on wood, unless Jn 19 19 contradicts this.

Woven linen as a writing substance had some fame in antiquity (*libri linei*), and many other fibers which have been used for woven or embroidered writing are, broadly speaking, of wood. So too, in fact, when linen or wood is pulped and made into paper, the material is still wood. Most modern writing and printing is thus on wood. See 10, below.

Diogenes Laertius (vii.174) tells that Cleanthes wrote on the shoulder-blades of oxen, but he was preceded by the cave-dwellers of the

**7. Bones and Skins** Neolithic age, who wrote on reindeer horns and bones of many kinds (Déchelette, *Arch. préhist.*, 1908, 125, 220-37, *et passim*). Ivory has often been used and was a favorite material for tablets in classical times. The LXX translates "ivory work" of Cant 5 14 as "ivory tablets." Horns are given in late Heb (*Tōsephā'*, qt. Blau, 16) as a possible material for writing. They have been used at all times and are well illustrated in modern times by the inscribed powder horns.

The hides of living animals have served for branding, and living human skin for painting, branding and tattooing extensively in all lands and all times. The literature of ceremonial painting and tattooing is very extensive, and the branding of slaves was common in many lands. See PRINTING.

The use of skins prepared for writing on one side (leather) was early and general, dating back as far at least as the IVth Dynasty of Egypt. The Annals of Thutmose III in Pal were written on rolls of leather. Its use was common also in Persia (Diodorus ii.32; Herod. v.58; Strabo xv.1), and it was a natural universal material. It has been much used by modern American Indians. It was the usual material of early Heb books, and the official copies at least of the OT books seem always to have

been written on this material (Blau, 14-16), and are so, indeed, even to the present day.

Vellum is simply a fine quality of leather prepared for writing on both sides. The autographs of the

NT were most likely written on papyrus, rather than leather or vellum, but most of the earliest codices and all, until recent discoveries, were on this material, while

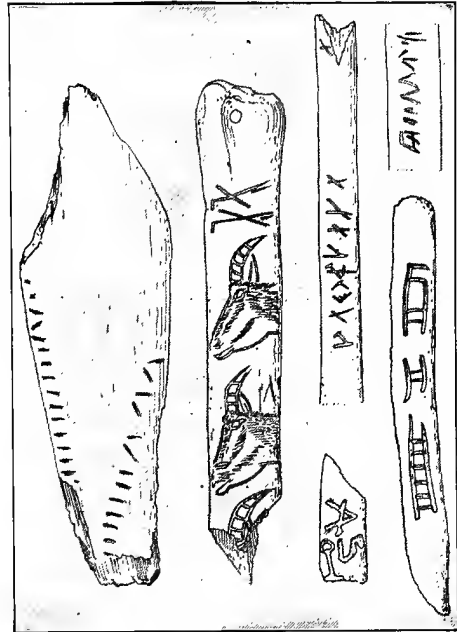

Signs of the Cave-Dwellers.

very few of the long list of MSS on which the NT text is founded are on any other material. This material is referred to as parchment by St. Paul (2 Tim 4 13). Almost every kind of skin (leather or vellum) has been used for writing, including snake skin and human skin. The *palimpsest* is second-hand or erased vellum, written upon again. See PARCHMENT; PARCHMENTS.

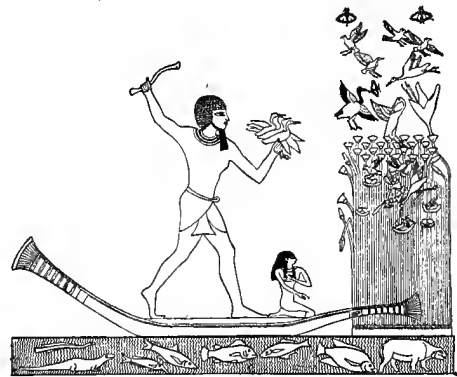

Papyrus Marsh with Boat (Bulrushes and Boat of Bulrushes).

Papyrus was not only the chief of the vegetable materials of antiquity, but it has perhaps the longest record of characteristic general use of anything except stone. The papyrus was made from a reed cultivated chiefly in Egypt, but having a variety found also in Syria, according to Theophrastus. The

papyrus reed grows in the marshes and in stagnant pools; is at best about the thickness of one's arm, and grows to the height of at most from 12 to 15 feet. It was probably a pool of these papyrus reeds ("flags") in which Moses was hidden (Ex 3 3), and the ark of bulrushes was evidently a small boat or chest made from papyrus reeds, as many of the Egypt boats were. These boats are referred to in Isa 18 2.

Papyrus was made by slicing the reed and laying the pieces crosswise, moistening with sticky water, and pressing or pounding together. The breadth of the manufactured article varied from 5 in., and under, to 9½ in., or even to a foot or a foot and a half. The earliest Egypt papyrus ran from 6 to 14 in. Egypt papyri run to 80, 90 and even 135 ft. in length, but the later papyri are generally from 1 to 10 ft. long. The use of papyrus dates from before 2700 BC at latest.

Many Bible fragments important for textual criticism have been discovered in Egypt in late years. These, together with the light which other papyri throw on Hellenistic Gr and various paleographical and historical problems, make the study of papyri, which has been erected into an independent science, one of very great importance as to Bib. history and Bib. criticism (cf Mitteis u. Wilcken, *Grundzüge . . . d. Papyruskunde*, Leipzig, 1912, 2 vols in 4). It has been argued from Jer 36 23 that the book which the king cut up section by section and threw on the fire was papyrus. This argument is vigorously opposed by Blau (14, 15), but the fact of the use of papyrus seems to be confirmed by the tale that the Romans wrapped the Jewish school children in their study rolls and burned them (*Ta'āmīh* 69a, qt. Blau, 41). Leather would have been poor burning material in either case. Certainly "papyrus" is freely used by the LXX translators and the word *biblion* is (correctly) tr<sup>d</sup> by Jerome (Tob 7 14) by *charta*. It is referred to in 2 Jn ver 12, "paper and ink," as the natural material for letter-writing. See PAPHYRUS, PAPHYRI.

The introduction of paper was from Western Asia, possibly in the 8th cent., and it began to be used in Europe commonly from the 10th cent. While few Western MSS of any importance are on paper, many of the Eastern are. It was the invention of paper, in large measure, which made possible the immense development in the multiplication of books, since the invention of printing, and the enormous number of Bibles now in existence.

Of the many materials used in order to lay one contrasting color on another, the flowing substances, paint and ink, are commonest. In general throughout antiquity the ink was dry ink and moistened when needed for writing. Quite early, however, the liquid inks were formed with the use of gall nut or acid, and many recipes and formulas used during the Middle Ages are preserved. See INK, INK-HORN. The reading of a palimpsest often depends on the kind of ink originally used and the possibility of reviving by reagents.

**VI. Forms.**—The best known ancient forms of written documents are the tablet or sheet, the roll, the diploma and the codex. These may be analyzed into one-face documents and many-faced documents—page documents and leaf documents. The roll, the diploma and the usual folding tablet or pleated document are forms of the one-page document, while the codex or bound book (Eng. "volume") is the typical leaf document. The roll is the typical form of the OT, the codex of the NT, extant MSS.

A book as regards its material form consists of a single limited surface suited for writing, or a succession of such surfaces. This single surface may be the face of a cliff or house wall, a broken piece of

pottery, a leaf, a sheet of lead, papyrus, vellum or paper, a tablet of clay, stone or wood, a cylinder, prism, cone, pyramid, obelisk, statue or any one of the thousands of inscribed objects found among votive offerings. The typical form is the flat surface to which the term "tablet" or "sheet" is applied, and which is called "page" or "leaf" according as one or both surfaces are in mind.

These single flat leaves are characteristically quadrilateral, but may be of any shape (circular, oval, heart-shaped, etc) or of any thickness, from the paper of an Oxford Bible or equally thin gold foil up to slabs of stone many inches thick.

When the document to be written is long and the sheet becomes too large for convenient handling, space may be gained by writing on both sides or by making still larger and either folding or rolling, on the one hand, or breaking or cutting up into a series of smaller sheets, on the other. This folding or rolling of the large sheet survives still in folded or rolled maps and the folded or rolled documents (diplomas) of mediaeval and modern archives. The use of the tablet series for long works instead of one overgrown tablet was early—quite likely as early as the time of actual writing on real "leaves."

These smaller tablets or sheets were at first, it would seem, kept together by numbering (cf Dziatzko, *Ant. Buchw.*, 127), catchwords, tying in a bundle, or gathering in a small box (*capsa*). This has indeed its analogy with the mnemonic twig bundle of object writing. The Pent gets its name from the five rolls in a box, jar, or basket (Blau, 65; Birt, *Buchrolle*, 22).

The next step in the evolution of book forms was taken when the various leaves or sheets were fastened to each other in succession, being strung, pasted or hinged together.

The stringing together is as early and primitive as the leopard-tooth trophy necklaces of the African chief or the shell and tooth necklaces of quaternary Europe (*Déchelette, Arch.*, 208-9). It was perhaps used with annual tablets in the first dynasties of Egypt and is found in oriental palm-leaf books today.

The roll consists normally of a series of one-surface sheets pasted or sewed together. Even when made into a roll before writing upon, the fiction of individual tablets was maintained in the columns (*deleths*, Jer 36 23="doors"). It was the typical book form of antiquity. It was commonly of leather, vellum, papyrus, and sometimes of linen. It might rarely be as much as 135 ft. long × 1½ ft. wide for papyrus, and leather rolls might be wider still. It was the form traditionally used by the Hebrews, and was undoubtedly the form used by Our Lord in the synagogue. It is still used in the synagogue. It was possibly the form in which the NT books also were written, but this is much more doubtful.

The roll form is founded on the one-surface tablet, and, as a matter of fact, neither leather nor papyrus was well suited to take ink on the back; it developed from the sewing together of skins and the pasting together of sheets of papyrus. Although papyrus is found written on both sides, it is in general not the same document on the back, but the old has been destroyed and utilized as waste paper. This writing on both sides of the roll (opisthography) is referred to in Ezk 2 10 (Rev 5 1), where the roll is written within and without.

Wood and metal tablets, not being flexible, could not be rolled, but were hinged and became diptychs, triptychs, polyptychs. The typical

**2. The Codex** method of hinging these tablets in Rom times was not the codex or modern book form proper, where all are hinged by the same edge, but a folding form based on a series of one-surface tablets hinged successively so as to form a chain (Gardthausen, *Gr Pal*, I, 129, fig. 12). They were strictly folding tablets, folding like an accordion, as in some Far

Eastern MSS of recent times. The modern hinging was used but rarely.

It is commonly said that it was this folding or hinged wooden tablet which produced the *codex* of the Latins and the "book" of modern Germanic races. Some, however, prefer to trace the origin to the folded document. The wood or waxed tablet was commonly used in antiquity for letters, but even more commonly the sheet of papyrus or vellum. It is quite natural to fold such a sheet once to protect the writing. Whether this was suggested by the diptych, or vice versa, the form of a modern sheet of note paper was early introduced. Either the diptych or the folded single sheet may have suggested the *codex*.

Whether the first *codices* were wood and metal or papyrus and vellum, the hinging at one edge, which is the characteristic, is closely connected with the double- (or multiple-) face tablet. With suitable material the simplest way of providing space, if the tablet is too small, is to turn over and finish on the back. The clay tablets lend themselves readily to writing on both sides, but not to hinging. It developed, however, to a certain degree the multiple-face idea by use of prisms, pyramids, hexagonal and other cylinders, but it was early forced into the numbered series of moderate-sized tablets.

Wood and metal tablets would be hinged, but the wood tablets were too bulky and metal tablets too heavy for long works, and the ring method of joining actually led away from the book to the pleated form. Papyrus and leather, however, while they might be used (as they were used) as single tablets were thin enough to allow of a long work in a single *codex*. They soon developed, therefore, perhaps through the folded sheet, into the *codex* proper and the modern bound book. The *codex*, as Thompson remarks, was destined to be the recipient of Christian literature, as the papyrus roll had been the basis of the pagan literature, and there is some evidence to show that the form was, historically, actually developed for the purposes of the Christian writings, and in papyrus, while the pagan papyri continued to be in roll form. Since the invention of the *codex* is placed at the end of the 1st cent., and the earliest *codices* were esp. the NT writings, there is a certain possibility that at least the historical introduction of the *codex* was in the NT books, and that its invention comes perhaps from combining the NT epistles on papyrus into a volume. In the West at least the roll is, however, the prevailing form of the NT until the 3d or 4th cent. (Birt, *Buchrolle, passim*).

**VII. Writing.**—The chief Heb words for the professional "writer" are *šōphēr* and *šōtēr*, both akin to

Assyr words for "writing" and used  
**1. Writers** also for kindred officers. The word *šōphēr* seems closely connected with the *šēpher*, "book," and with the idea of numbering. This official is a military, mustering or enrolling officer (Jgs 5 14; 2 Ch 26 11; 2 K 25 19), a numbering or census officer for military purposes or for taxation (Isa 33 18)—and a royal secretary (2 S 8 17).

The *šōtēr* appears as a herald (Dt 20 5,8; Josh 1 10; 3 2), as overseer of the brick-making in Egypt, and as overseer of the outward business of Israel (1 Ch 26 29). He is associated with the elders (Nu 11 16; Dt 29 10 [Heb 9]; 31 28; Josh 8 33; 23 2; 24 1) or with the judges (Josh 8 33; 23 2; 24 1; Dt 16 18).

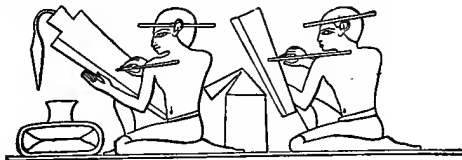

Scribes with Utensils.

The two terms are often, however, used together as of parallel and distinct offices (2 Ch 26 11; 34 13). If any such distinction can be made, it would seem that the *šōphēr* was originally the military scribe and the *šōtēr* the civil scribe, but it is better to say that they are "evidently . . . synonymous terms and could be used of any subordinate office which required ability to write" (Cheyne in *EB*). There seem to have been at least 70 of these officers at the time of the Exodus, and by inference many more (Nu 11 16), and 6,000 Levites, alone in the time of David (1 Ch 23 4) were "writers."

Another kind of professional scribe was the *šār*-

*šār* (Jer 51 27, "marshal"; Nah 3 17 m), or tablet writer, a word apparently directly borrowed from the Assyr. This too seems to be a real synonym for both of the other words. In brief, therefore, all three terms mean scribe in the Egypt or Assyr sense, where the writer was an official and the official necessarily a writer.

Still another word, rendered in RV as "magicians," is rendered in its margin as "sacred scribe" (*ḥarṭōm*). This word being derived from the *štilus* recalls the close connection between the written charm and magic. None of these words in the OT refers directly to the professional copyist of later times whose business was the multiplication of copies.

Sayce argues from the name Kiriath-sepher that there was a university for scribes at this place, and according to 1 Ch (2 55) there were Kenite families of professional scribes at Jabez.

The professional scribe, writing as an amanuensis, is represented by Baruch (Jer 36 4) and Tertius (Rom 16 22), and the calligraphist by Ezra (Ezr 7 6). In later times the scribe stood for the man of learning in general and esp. for the lawyer.

It would seem that Moses expected that kings should write with their own hands (Dt 17 18; 31 24), and the various letters of David (2 S 11 15), Jezebel (1 K 21 9), the king of Aram (2 K 5 5), Jehu (2 K 10 2,6), Jeremiah (ch 29), Elijah (2 Ch 21 12-15), the letters of the Canaanite and Hittite princes to one another in the Am Tab and Boghaz-keui tablets, etc, while they may sometimes have been the work of secretaries, were undoubtedly often by the author. For the prevalence of handwriting in Bib. times and places see LIBRARY. Its prevalence in OT times may be compared perhaps to the ratio of college graduates in modern life. In NT times the ratio was probably much greater, and it appears not only that Zacharias, the priest, and the educated St. Paul and St. Luke could write, but even the poorer apostles and the carpenter's Son. It is assumed that all of a certain rich man's debtors could write (Lk 16 7). This general literacy was due to the remarkable public-school system of the Jews in their synagogues, which some good Jewish scholars (Klostermann, qt. Krauss, *Talmud. Archaeol.*, III, 336, n.1) trace as far back as Isaiah. In Vespasian's time it is said there were in Jerus alone 480 synagogues each with its school, and the law that there must be primary schools in every city dates at latest (63-65 AD) from this time and more likely from 130 BC. The compulsory public-school law of Simeon ben Setach (c 70 BC), although it has been labeled mythical, is nevertheless entirely credible, in view of the facts as they appear in NT times and in Jos. The tale that there were in Bethel, after the fall of Jerus had crowded full this seat of learning, "400 synagogues each with 400 teachers and 400 pupils," carries fiction on its face, but there is little doubt that there were public schools long before this in nearly every town of Pal and compulsory education from the age of 6 or 7 (cf Krauss, III, ch xii, "Schule," 119-239, 336-58).

Writing in the Heb as in Sem languages in general except Ethiopic is from right to left and in Gr from left to right as in modern western

**2. The usage.** On the one hand, however, **Writing Art** some Sabaean inscriptions and, on the other hand, a number of early Gr inscriptions are written alternately, or *boustrophedon*, and suggest the transition from Sem to western style. The earlier Gr MSS did not separate the words, and it is inferred from text corruptions that the earliest Heb writing did not. As early as the Mesha and Siloam inscriptions, the dot was used to separate words, and the vertical stroke for the end of a sentence. Vowel points were introduced somewhere

from the 5th to the 8th cent. AD by the Massorettes, but are not allowed even now in the synagogue rolls. Some of the inscriptions employ the Palestinian or Tiberian system of vowel points, and others the Bab (above the line). Accents indicate not only stress but intonation and other relations. Very soon after Ezra's day, and before the LXX tr, the matter of writing the Bib. books had become one of very great care, the stipulations and the rules for careful correction by the authorized text being very strict (Blau, 185-87). The MSS were written in columns (doors), and a space between columns, books, etc, was prescribed, as also the width of the column. All books were ruled. Omitted words must be interlined above. The margins were frequently used for commentaries. For size, writing on the back, etc, see above, and for the use of abbreviations, reading, punctuation, etc, see Blau, Gardthausen, Thompson, the Introductions to textual criticism and the arts. on textual criticism in this Encyclopaedia.

**VIII. History of Biblical Handwriting.**—Mythologically speaking the history of handwriting dates from the beginning when the Word

**1. Mythological Origins** is a series of heavenly tablets, the handwriting of God, as conceived by the tablet-using Babylonians, or a scroll in the thought of prophets, the NT writers, and the rabbis. Whether the idea that "the heavens declare the glory of God," etc (Ps 19 1-4), refers to this notion or not, it was one extensively developed and practised in the science of astrology. In any event the doctrine of the Creator-Word reaches deep into the psychology of writing as a tangible record of invisible words or ideas, and this philosophizing stretches some 3,000 years or so back of the Christian era.

For writing among the gods in the mythologies of non-Bib. religions, see **BOOK; LIBRARY.**

When and why the very simplest kind of writing began to be used has been the subject of much conjecture. The *Enc Brit* (XVI, 445)

**2. Earliest Use** suggests that "the earliest use . . . of inscribed or written signs was for important religious and political transactions kept by priests in temples," but the memorial pillar is older than the temple, and the economic or social record is perhaps older than the sacred, although this is less clear. Three things seem rather probable: (1) that the first records were number records, (2) that they concerned economic matters—although it is not excluded that the occasion for first recording economic matters was religious, (3) that they were not used memorially for important transactions, but rather as utilitarian or business records.

The original mnemonic record was probably a number record. The Heb words for "book," and "word" both seem to mean a setting down of one thing after another, and various words in various other languages point in the same direction, as do also in a general way the nature of the primitive situation and the evidences of history. Many of the oldest records are concerned with numbers of animals. Immense quantities of very old Sumerian records are simply such lists, and the still earlier cave drawings (whether they have numbers or not) are at least drawings of animals. One use of the primitive *quipu* was for recording sales of different kinds of animals at market, and the twig bundle and notched records are in general either pure number records or mnemonic records with a number base. What these animal records were for is another matter. If they were records of ownership for mere tally purposes (a natural enough purpose, carrying back even to hunting trophies) the use was purely economic, but as a matter of fact the early Bab lists seem generally to have been temple records, and even the cave records are commonly thought to be associated with religion. The early Egypt lists too have religious associations, and the somewhat later records are largely concerned with endowment of temples or at least temple lists of offerings—votive offerings or sac-

rifices. This points perhaps to a religious origin and possibly leads back to the very first felt need of records for a titling for religious purposes. But it may equally lead to the sharing of spoils socially rather than religiously, although the history of the common meal and sacrifice shared by worshippers points to a very early religious sanction for the problem of equitable sharing of spoils, and it may have been precisely at this point

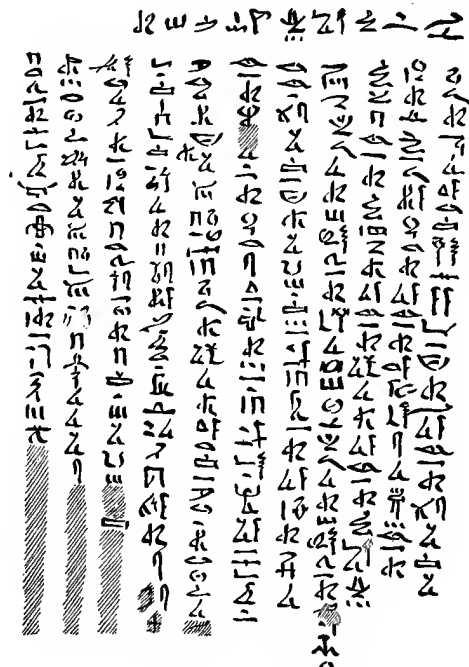

Common Egyptian Writing in the Time of Abraham.

and for this purpose that number record was invented. However that may be, the evidence seems to point to a number-record origin even back of the cave drawings (which are said to be chiefly of domestic rather than wild animals) at a period variously figured as from 6,000 or 8,000 years ago, more or less, to millions of years ago.

The pseudepigraphic books of the OT variously represent writing as invented and first practised by Jeh, Adam, Cain, or Seth. Taking

**3. Biblical History** the Bib. narrative as it stands, the earliest allusion to true writing is the sign of Cain (Gen 4 15), if indeed this refers to a body mark, and particularly if it has analogy with the "mark upon the forehead" of the Book of Rev (17 5; cf 13 16; 14 1) and the tattoo marks of ownership or tribal marks of primitive tribes, as is thought by many.

The setting of the rainbow as a permanent sign (Gen 9 12-17) for a permanent covenant is quite in line with the recognized mnemonic writing. Noah's building of an altar had the same character if it was built for a permanent memorial. More obviously akin to this primitive form of writing was, however, the dedication of a memorial altar or pillar as a memorial of a particular event in a particular place, as in Jacob's pillar (Gen 28 18,22).

For perhaps 2,000 years before Abraham, image writing had been practised in both Babylonia and Egypt, and for more than 1,000 years a very highly developed ideographic and phonetic writing had been in use. There were millions of cuneiform documents existing in collections large and small in Babylonia when he was there, and equal quantities of hieroglyphic and hieratic papyri, leather and skin documents in Egypt when he visited it. See **BOOK; LIBRARY; HAMMURABI, CODE OF.**

Abraham himself presumably used cuneiform writing closely parallel to the writing on Hammurabi's statue. A similar script was presumably also used by his Hittite allies. In Egypt he met with the hieroglyphics on the monuments, but for business and common use the so-called hieratic cursive forms were already developed toward, if not well into, the decided changes of the middle hieratic period (c 2030-1788 BC; cf Möller, *Hierat. Palaecog.*, VI, 1909, 3, etc). It is a question whether the boundary heap, which Laban "called" the heap of witness in Aram, and Jacob by the same name in Heb, was inscribed or not, but, if inscribed, both faces or lines of the bilingual inscription were presumably in cuneiform characters. The cuneiform remained, probably continuously, the prevailing script of Syria and Pal until about 1300 BC, and until, some time well before 1000, the old Sem alphabet began to be employed.

The question of the relation of the writing in Mosaic times and in the time of the Judges to the cuneiform or the hieratic on the one side and the alphabet on the other is too much mixed up with the question of the Pent to allow of much dogmatizing. Some scholars are convinced that the Pent was written in cuneiform characters if not in the Bab language. The old Sem-Gr, "Phoenician," alphabet was, however, probably worked out in the Palestinian region between 1400 and 1100 BC (wherever the Hebrews may have been at this time), and it remained the Heb writing until the introduction of the square characters. See ALPHABET.



•Common Egyptian Writing during the Bondage.

At the beginning of the Christian era there had been a long period of the use of Gr among the educated, and long before the NT was written there was a large body of Palestinian-Gr and Egypt-Gr literature. Latin for a time also had been used, more or less, officially, but the Aram., development of whose forms may be well traced from about 500

BC in the inscriptions and in the Elephantine papyri, was the prevailing popular writing. Gr remained long the language of the educated world. It was after 135 AD that R. Simeon ben Gamaliel was said to have had 500 students in Heb (New Heb) and 500 in Gr (Krauss, III, 203).

ΜΗΘΕΝΑΑΜΜΟΓΕΝΗΣΙΠΙΟ

CERVICIBVSASIDE MOLI

Three Writings in Common Use in Palestine in Gospel Times: First, Aramaic; Second, Greek; Third, Latin.

Latin, Gr, and Aram. (New Heb) characters were all needed for the inscription on the cross. Heb had at this time certainly passed into the square form long enough ago to have had *yōdh* pass into proverb as the smallest letter (jot) of the alphabet (Mt 5 18). Through the abundance of recent papyrus and inscriptional discoveries, it is now possible to trace the history of the varying forms of the bookhand and cursive Gr letters, and even of the Latin letters, for several centuries on either side of the year of Our Lord and up to the time of the longer known manuscripts (see works of Gardthausen and Thompson). One may get in this way a good idea of how the most famous of all trilingual inscriptions may have looked as to its handwriting—how in fact it probably did look, jotted down as memorandum by Pilate, and how transcribed on the cross, assuming that Pilate wrote the Rom cursive (Thompson, facs. 106 [AD 41], 321), and the clerks a fair epigraphic or rather for this purpose perhaps bookhand Greek (Thompson, facs. 8 [AD 1], 123; Latin, facs. 83 [AD 79], 276). See TITLE.

**LITERATURE.**—*General:* Edward Clodd, *Story of the Alphabet*, New York, 1912 (popular); Fritz Specht, *Die Schrift u. ihre Entwicklung*, 3. Ausg., Berlin, 1909 (popular); I. Taylor, *History of the Alphabet*, London, 1899, 2 vols, 8vo; H. Wutke, *Geschichte der Schrift*, Leipzig, 1874-75 (rich and comprehensive on primitive writing); Philippe Berger, *Histoire de l'écriture dans l'antiquité*, 2d ed, Paris, 1892; Karl Faulmann, *Illustrirte Geschichte der Schrift*, Wien, 1880 (uncritical but comprehensive and very useful for illus.); W. M. Flinders Petrie, *The Formation of the Alphabet*, 1912.

*Primitive:* Leo Frobenius, *The Childhood of Man*, Philadelphia, 1908 (casual but useful aggregation of primitive examples); Frederick Webb Hodge, ed., *Handbook of American Indians North of Mexico*, Washington, 1907-10, 2 vols (dictionary form); G. Mallory, *Smithsonian Inst. Reports*, IV (1882-83), 3-256, X (1888-89), 1-822; M. Beuchat, *Manuel d'archéologie américaine*, Paris, 1912; M. H. Kingsley, *Travels in West Africa*, London, 1897; R. E. Dennet, *At the Back of the Black Man's Mind*, 1906; A. W. Howitt, *Native Tribes of South-East Australia*, London, 1904 (esp. ch xi); E. C. Richardson, *The Beginnings of Libraries*, London and Princeton, 1914.

*Mediterranean:* Déchelette, *Archéologie préhistorique*, 1908; Arthur J. Evans, *Scripta Minoa*, Oxford, 1909; Angelo Mosso, *The Dawn of Mediterranean Civilization*, London, 1910.

*Hebrew, Greek and Latin:* Frederic G. Kenyon, *Our Bible and the Ancient MSS*, 3d ed, London, 1898; George Milligan, *The NT Documents*, 1913, Ludwig Blau, *Studien zum alt-hebräischen Buchwesen*, Strassburg, 1902 (scholarly; first rank); Leopold Loew, *Graphische Requisiten und Erzeugnisse bei den Juden*, Leipzig, 1870-71, 2 pts.; Samuel Krauss, *Talmudische Archäologie*, Leipzig, 1910-12, 3 vols, III, 131-239, 300 ff (full critical notes and references); Mark Lidzbarski, *Handbuch d. nord-semitischen Epigraphik*, 1902-8 (also *Ephemeris*); Alvin

Sylvester Zerbe, *Antiquity of Heb Writing and Literature*, Cleveland, 1911 (controversial); V. Gardthausen, *Griechische Palaeographie*, 2d ed, Leipzig, 1911-13, 2 vols (remarkable for comprehensiveness, exhaustive bibliographic reference and critical scholarship); Sir Edward Maunde Thompson, *An Intro to Gr and Lat Palaeography*, Oxford, 1912 (expansion of his Handbook with greatly improved facsimiles, better treatment of papyri and a good working bibliography of palaeography); F. G. Kenyon, *The Palaeography of Gr Papyri*, Oxford, 1899, 8vo; Ludwig Mitteis and Ulrich Wilcken, *Grundzüge und Chrestomathie der Papyrskunde*, Leipzig, 1912, 2 vols in 4 (Encyclopaedia of the subject); Theodor Birt, *Das antike Buchwesen*, Berlin, 1882; idem, *Die Buchrolle in der Kunst*, Leipzig, 1907 (of first usefulness, esp. in matter of illus. and refs.); E. S. Roberts, *Gr Epigraphy*, pt. I, "The Archaic Inscriptions and the Gr Alphabet," Cambridge, 1887, 8vo; Karl Dziatzko, *Untersuchungen über ausgewählte Kapitel des antiken Buchwesens*, Leip-

zig, 1900; Ernest Christian Wilhelm Wattenbach, *Das Schriftwesen im Mittelalter*, Leipzig, 1896 (has an immense mass of original quotations of authorities).

Sources for latest literature: W. Weinberger, "Beiträge zur Handschriftenkunde," *Sitzungsber. Akad. Wien*, 159, 161 (1908-9), pp. 79-195; *Zentralblatt f. Bibliothekswesen*, Leipzig (monthly); Hortschansky, *Bibliographie des . . . Buchwesens* (annual cumulation of the *Zentralblatt* material).

For inward writing see modern general psychologies and the books and articles in Rand's bibliographical supplement to Baldwin's *Dict. of Psychology*. For continuation literature see the *Psychological Index*. For various aspects of writing consult also books on general Bib. archaeology (e.g. Nowack and Benzinger), general Intros. and arts. on "Alphabet," "Book," "Library," "Manuscripts," "Textual Criticism," and other special topics in this or other Bib. and general encyclopaedias.

E. C. RICHARDSON

X

**XANTHICUS**, zan'thi-kus (Ξανθικός, *Xanthikós*): The name of a month which occurs in 2 Macc 11 30.33.38. It corresponds to Nisan (April) of the Jewish calendar. See CALENDAR; TIME; YEAR.

**XERXES**, zérks'ez: The name is an attempt to transliterate into Gr (Ξέρξης, *Xérxēs*) the Pers *Khshayārshā*. The same word in unpointed Heb took the form 'hshwrsh, probably pronounced 'āhshāwārash, but at a later time it was wrongly vocalized so as to produce 'āhashwērōsh (אַחַשְׁוֵרֶשׁ), whence "Ahasuerus" in EV.

Xerxes was king of Persia in 485-465 BC. The

first part of his reign was marked by the famous campaign into Greece, beginning in 483. After the defeat at Salamis in 480 Xerxes himself withdrew from the expedition and it was finally discontinued in the next year. During the remainder of his reign, Xerxes seems to have spent a listless existence, absorbed in intrigues of the harem, and leaving the government to be carried on by his ministers and favorites (often slaves). He was finally murdered by his vizier and left an unenviable reputation for caprice and cruelty.

For the various Bib. references see AHASUERUS. BURTON SCOTT EASTON

Y

**YARN**, yārn. See LINEN; SPINNING; WEAVING.

**YEA**, yā (אֵף, 'aph, "also," "moreover," "yea" [1 S 21 5 AV; 24 11, etc], גַּם, gam, "also," "likewise," "moreover," "yea" [2 K 2 3; 1. In the 16 3, etc], כִּי, ki, "inasmuch," "certainly," "doubtless," "yea" [Ps 102 13; 105 12, etc]): Each of these words occurs frequently, esp. the first two.

In the NT we have: *val, nai*, "verily," "yea," the usual particle of affirmation (Mt 5 37; 9 28, etc); *δέ, dé*, "however," "on the other hand" (Lk 2 35; Acts 20 34 AV, etc); NT *ἀλλά, allá*, "however," "but" (Lk 24 22 AV; Rom 3 31 AV, etc); *καί, kai*, "also," "besides," "yea" (Acts 3 16; 7 43 AV, etc). Christ forbids the employment of any affirmation stronger than the solemn repetition of the first mentioned (Mt 5 37). FRANK E. HIRSCH

**YEAR**, yēr (שָׁנָה, *shānāh*, Aram. שָׁנָה, *shēnāh*, "a return" [of the sun], like the Gr *ἐνιαυτός, eniautós*; יָמִים, *yāmīm*, "days," is also used for "year," and the Gr *ἡμέραι, hēmérai*, corresponds to it [Josh 13 1; Lk 1 7.18]; *ἔτος, étos*, is also employed frequently in the NT; for the difference between *etos* and *eniautos*, see Grimm-Thayer, s.v.): The Heb year was solar, although the month was lunar, the adjustment being made in intercalation. See ASTRONOMY; TIME.

**YEARS, SEVENTY**. See SEVENTY YEARS.

**YELLOW**, yel'ō. See COLORS.

**YODH**, yōd, yōth (י): The 10th letter of the Heb alphabet; transliterated in this Encyclopaedia

as *y*. It came also to be used for the number 10. See JOD, and for name, etc, see ALPHABET.

**YOKE**, yōk:

(1) The usual word is עֹל, 'ol (Gen 27 40, etc), less commonly the (apparently later) form מִוְקָה, *mōqāh* (Isa 58 6, etc; in Nah 1 13 מִוְתָּה, *mōtāh*), which RV in Jer 27, 28 translates "bar" (a most needless and obscuring change). The Gr in Apoc

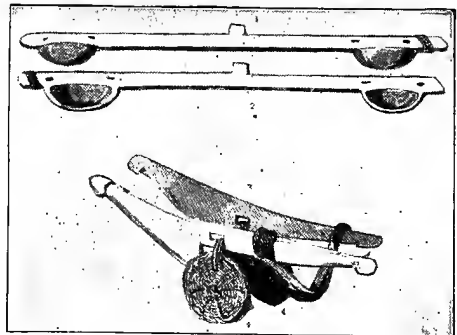

Yoke of Ancient Plow.

1, 2. Back and front of yoke. 3. Shoulder pieces. 4, 4. Matting to prevent friction of shoulders.

(Sir 28 19, etc) and in the NT (Mt 11 29f, etc) is invariably *ζυγός, zugós*. Egypt monuments show a yoke that consisted of a straight bar fastened to the foreheads of the cattle at the root of the horns, and such yokes were no doubt used in Pal also; but the more usual form was one that rested on the neck (Gen 27 40, etc). It was provided with straight "bars" (*mōlāh* in Lev 26 13; Ezk 34 27) projecting downward, against which the shoulders

of the oxen pressed, and it was held in position by thongs or "bonds" (*mōserōth* in Jer 2 20; 5 5; 27 2; 30 8; *'āghuddōth* in Isa 58 6, "bands"), fastened under the animals' throats. Such yokes could of course be of any weight (1 K 12 4 ff), depending on the nature of the work to be done, but the use of "iron yokes" (Dt 28 48; Jer 28 13 f) must have been very rare, if, indeed, the phrase is anything more than a figure of speech.

What is meant by "the yoke on their jaws" in Hos 11 4 is quite obscure. Possibly a horse's bit is meant; possibly the phrase is a condensed form for "the yoke that prevents their feeding"; possibly the text is corrupt. See JAW.

The figurative use of "yoke" in the sense of "servitude" is intensely obvious (cf esp. Jer 27, 28). Attention needs to be called only to Lam 3 27, where "disciplining sorrow" is meant, and to Jer 5 5, where the phrase is a figure for "the law of God." This last use became popular with the

Lydia, Epaphroditus, each of whom had in one way or another some connection with Philippi.

(2) Renan has suggested that yoke-fellow means Lydia (Acts 16 14.15.40), and that she had been married to Paul. But the fact that the adj. *gnēsios*, "true," qualifying "yoke-fellow" is masc. and not fem. shows that it is not a woman but a man who is referred to. Renan's suggestion is an unworthy one, and is quite devoid of proof. It is a mere fanciful and unsupported creation of the Frenchman's brain. Renan's idea is a modification of an opinion which is as old as Clement of Alexandria, that Paul here referred to his own wife. But this conjecture is contradicted by the statement of the apostle himself, that he had not a wife (1 Cor 7 8; 9 5).

(3) There is still another way of interpreting "yoke-fellow," and probably it is the right one. Some expositors take the word as a proper name. Among these Westcott and Hort print "Sunzuge," in the margin. In favor of this interpretation there is much to be said, esp. the fact that the word is found in the very midst of the names of other persons.



PLOWING IN SYRIA WITH YOKES OF OXEN.

Jews at a later period and it is found, e.g. in Apoc Bar 41 3; Ps Sol 7 9; 17 32; Ab, iii.7, and in this sense the phrase is employed by Christ in Mt 11 29 f. "My yoke" here means "the service of God as I teach it" (the common interpretation, "the sorrows that I bear," is utterly irrelevant) and the emphasis is on "my." The contrast is not between "yoke" and "no yoke," but between "my teaching" (light yoke) and "the current scribal teaching" (heavy yoke).

(2) "Yoke" in the sense of "a pair of oxen" is *צמד*, *ḥamedh* (1 S 11 7, etc), or *ξεύγος*, *zeúgos* (Lk 14 19).

See also UNEQUAL; YOKE-FELLOW.

BURTON SCOTT EASTON

**YOKE-FELLOW**, *yōk'fel-ō* (*σύνζυγος*, *súnzygos*, "yoked together"): The word is used by Gr writers of those united by any bond, such as marriage, relationship, office, labor, study or business; hence a yoke-fellow, consort, comrade, colleague or partner.

(1) In the NT it occurs once only (Phil 4 3): "I beseech thee also, true yoke-fellow." Most interpreters hold that Paul here addresses some particular but unnamed person, who had formerly been associated with him in the work of the gospel in Philippi. Many guesses have been made in regard to the identity of the unnamed "yoke-fellow," and these names have been suggested: Luke,

The names of Euodia and Syntyche are mentioned immediately before, and that of Clement follows immediately after the true yoke-fellow. The meaning therefore is probably, "I beseech thee also, true Synzygos," i.e. I beseech thee, who art a genuine Synzygos, a colleague rightly so called, a colleague in fact as well as in name. It is obvious to compare the way in which the apostle plays upon the name Onesimus, in Philem ver 11.

JOHN RUTHERFURD

**YOUNG, yung, MEN, YOUNG WOMEN** (*בְּחִירִים*, *bāhūr*, *בָּצֵר*, *na'ar*; *νεανίας*, *neanias*, *νεανίσκος*, *neaniskos*): "Young man" is generally in the OT the tr of *bāhūr*, from *bāhar*, "to prove," "to choose," and of *na'ar* (lit. "boy," but used sometimes also of a girl). The former term denotes a young man, no longer a mere youth, but liable to military service (Dt 32 25; Jgs 14 10; 1 S 8 16; 2 K 8 12, etc). In Nu 11 28, AV "Joshua . . . the servant of Moses, one of his young men" (*b'harīm*), RV renders "one of his chosen men," m "from his youth." *Na'ar* is frequently used (sing. and pl.) of soldiers (1 S 14 1.6; 21 4; 25 5.8.9; 2 S 1 5.6.15, etc). Abraham's "young men" (*ne'ārīm*) were "trained servants," "trained men," warriors (Gen 14 24; cf ver 14 RV). The word is often in the OT trd "servant": thus in RV for AV "young man," "young men" (Gen 18 7; 2 K 4

22; 1 K 20 14 RVm). In the NT, the ordinary words for "young man" are *neanias* (Acts 7 58; 20 9; 23 17.18.22) and *neaniskos* (Mt 19 20.22; Mk 14 51, etc). "Young men" in Acts 5 6 is *neōteroi*, comparative of *néos*, "young," recent; the fem. of the latter word is "young women" in Tit

2 4, and *neōterai* is "younger women" (RV "widows") in 1 Tim 5 14. In both the OT and the NT young men are earnestly exhorted to wisdom and sober-mindedness (Prov 1 8.9; Eccl 11 9; 12 1.13.14; Tit 2 6, "discreet"; cf Wisd 9 11), etc. W. L. WALKER

Z

**ZANAANIM**, zā-a-nā'im. See ZAANANNIM.

**ZANANAN**, zā'a-nan (זָנַנָן, *ḡā'ānān*; Ζενναάν, *Sennadr*): A place named by Micah in the Shephelah of Judah (1 11). In this sentence the prophet makes verbal play with the name, as if it were derived from *yāḡā*, "to go forth": "The inhabitant [m "inhabitant"] of *ḡā'ānān* is not come forth" (*yāḡā'āh*). The place is not identified. It is probably the same as ZENAN.

**ZANANNIM**, zā-a-nan'im, PLAIN OR OAK OF (זָנַנִּים בְּצִעְנִים, *'ēlōn b'ḡa'ānayim*, or זָנַנִּים בְּצִעְנִים, *b'ḡa'ānanīm*; B, Βεσανιεύ, *Besaniéin*, A, Βεσανανίμ, *Besananīm* [Josh 19 33]; in Jgs 4 11 B translates *πλεονεκτούντων*, *pleonektoúntōn*, and A, *ἀναπαυμένων*, *anapauménōn*): In Josh 19 33 AV reads "Allon to Zaanannim," RV "the oak in Zaanannim," RVm "oak [or terebinth] of Bezaanannim." In Jgs 4 11 AV reads "plain of Zaanaim," RV "oak in Zaanannim." It is probable that the same place is intended in the two passages. It was a place on the southern border of the territory of Naphtali (Josh), and near it the tent of Heber the Kenite was pitched (Jgs). The absence of the art. before *'ēlōn* shows that the *b'* is not the preposition before *z*, but the first letter of the name, which accordingly should be read "Bezaanannim." We should naturally look for it near Adami and Nekeb. This agrees also with the indications in Jgs, if the direction of Siserā's flight suggested in MEROZ (q.v.) is correct. The Kadesh, then, of Jgs 4 11 may be represented by the ruin *Kādīsh* on the western shore of the Sea of Galilee; and in the name *Khīrbet Bessūm*, about 3 miles N.E. of Tabor, there is perhaps an echo of Bezaanannim. W. EWING

**ZAAVAN**, zā'a-van (זָאָוָן, *zā'āwān*, meaning unknown): A Horite descendant of Seir (Gen 36 27; 1 Ch 1 42). In 1 Ch Luc. has *Zavāv*, *Zavān* = *Sam* זָאָוָן, i.e. *Zaw'ān*, from a root meaning "to tremble," "fear" (see זָרַע, *BDB*). AV has "Zavan" in 1 Ch.

**ZABAD**, zā'bad (זָבָד, *zābhādh*, perhaps a contraction for [1] *z'bhādhyāh*, "Jeh has given," i.e. Zebadiah; or [2] *zabhdī'el*, "El [God] is my gift" [*HPN*, 222 f]; Ζαβεδ[ε]ι, *Zabéd[é]*, with many variants):

- (1) A Jerahmeelite (1 Ch 2 36.37), son of Nathan (see NATHAN, IV).
- (2) An Ephraimite, son of Tahath (1 Ch 7 21).
- (3) Son of Ahlai (1 Ch 11 41) and one of David's mighty men (the name is wanting in 2 S 23 24-29).
- (4) Son of Shimeath the Ammonitess (2 Ch 24 26); he was one of the murderers of King Joash of Judah; called "Jozacar" in 2 K 12 21 (Heb ver 22). Perhaps the name in Ch should be Zacar (זָכָר, *zākhār*).
- (5) Name of three men who had married foreign wives: (a) son of Zattu (Ezr 10 27) = "Sabathus" of 1 Esd 9 28; (b) son of Hashum (Ezr 10 33) = "Sabanneus" of 1 Esd 9 33; (c) son of Nebo (Ezr 10 43) = "Zabadeas" of 1 Esd 9 35.

DAVID FRANCIS ROBERTS

**ZABADAEANS**, zab-a-dē'anz (Ζαβαδαίοι, *Zabadatōi*; AV *Zabadeans*; Oesterley, in Charles, *Apoc*, 1, 112, prefers, on what seems insufficient evidence, to read "Gabadeans"; Jos [*Ant*, XIII, v, 10] by an obvious error has "Nabateans"): According to 1 Macc 12 31, an Arabian tribe, defeated and spoiled by Jonathan after his victory in Hamath and before he came to Damascus. There is an *ez-Zebedānī* about 25 miles N.W. of Damascus (now a station on the railway to Beirut), on the eastern slope of the Anti-Lebanon range. This town may very well have preserved the name of the Zabadaeans, and its situation accords nicely with Jonathan's movements in 1 Macc 12.

BURTON SCOTT EASTON

**ZABADAIAS**, zab-a-dā'yas. AV = RV **ZABADEAS** (q.v.)

**ZABADEAS**, zab-a-dē'as (Ζαβαδαίας, *Zabadaias*; AV *Zabadaias*): One of the sons of Nooma who put away their foreign wives (1 Esd 9 35) = "Zabad" of Ezr 10 43.

**ZABBAI**, zab'ā-i, zab'ī (זַבַּי, *zabbay*, meaning unknown; Ζαβού, *Zabou*):

- (1) One of those who had married foreign wives (Ezr 10 28) = "Jozabudus" of 1 Esd 9 29.
- (2) Father of Baruch (Neh 3 20). The K<sup>r</sup>ē has זַכַּי, *zakkay* = "Zaccai" of Ezr 2 9; Neh 7 14.

**ZABBUD**, zab'ud (זַבּוּד, *zabbūdh*, meaning uncertain; Ezr 8 14, where K<sup>r</sup>ē is *zakkūr* and K<sup>t</sup>hībh is *zābhūdh* = "Zabud"; 1 Esd 8 40 has "Istalcarus"): A companion of Ezra on his journey from Babylon to Jerus.

**ZABDEUS**, zab-dē'us (Ζαβδαῖος, *Zabdaios*): In 1 Esd 9 21 = "Zebadiah" of Ezr 10 20.

**ZABDI**, zab'dī (זַבְדִּי, *zabhdī*, perhaps "[a] gift of Jeh" or "my gift" = NT "Zebedee"):

- (1) An ancestor of Achan (Josh 7 1.17.18). Some LXX MSS and 1 Ch 2 6 have "Zimri" (זִמְרִי, *zimrī*); "the confusion of ז [b] and ז [m] is phonetic, of ז [d] and ז [r] graphic" (Curtis, *Chron.*, 86). See ZIMRI (3).
- (2) A Benjamite, son of Shimei (1 Ch 8 19), and possibly a descendant of Ehud (Curtis).
- (3) "The Shiphmite," one of David's officers who had charge of the wine-cellars (1 Ch 27 27). LXX B has Ζαχρη, *Zachrei* (probably Zichri).
- (4) An ancestor of Mattaniah (Neh 11 17). Luc. and 1 Ch 9 15 have "Zichri." See ZICHRĪ, I, 2.

DAVID FRANCIS ROBERTS

**ZABDIEL**, zab'di-el (זַבְדִּי'ֵל, *zabhdī'el*, "my gift is El [God]"; Ζαβδιήλ, *Zabdiēl*):

- (1) Father of Jashobeam (1 Ch 27 2), or rather Ishbaal (Curtis, *Chron.*, 290 f).
- (2) An overseer of the priests (Neh 11 14).
- (3) An Arabian who beheaded Alexander Balas and sent his head to Ptolemy (1 Macc 11 17).

**ZABUD**, zā'bud (זַבּוּד, *zābhūdh*, "bestowed"):

- (1) A son of Nathan (the prophet, probably) said in K to be chief minister to Solomon and also the



king's friend (1 K 4 5; 1 Ch 2 36). ARV<sup>m</sup> has "priest" for "chief minister." Benzinger (*Kurz. Hand-Comm.*, 18) holds that "this expression is a marginal gloss here," while Kittel (*Handkomm.*, 31) holds it to be genuine, though it is wanting in LXX. Some suggest זָבֹּן, *šōkhēn* (see SHEBNA) for זָבֹּן, *kōhēn*. The expression "king's friend" (cf 2 S 16 37; 16 16) is, says Kittel, an old Can. title, found also in the Am Tab.

(2) See ZACCUR, (4); PRIESTS AND LEVITES.

DAVID FRANCIS ROBERTS

**ZABULON**, zab'ū-lon (Ζαβουλών, *Zaboulōn*): Gr form of "Zebulun" of Mt 4 13.16; Rev 7 8 AV.

**ZACCAI**, zak'ā-i, zak'ī. See ZABBAI, (2).

**ZACCHAEUS**, za-kē'us (Ζακχαῖος, *Zakchaíos*, from זָכַי, *zakkay*, "pure"):

(1) A publican with whom Jesus lodged during His stay in Jericho (Lk 19 1-10). He is not mentioned in the other Gospels. Being a chief publican, or overseer, among the tax-gatherers, Zacchaeus had additional opportunity, by farming the taxes, of increasing that wealth for which his class was famous. Yet his mind was not entirely engrossed by material considerations, for he joined the throng which gathered to see Jesus on His entrance into the city. Of little stature, he was unable either to see over or to make his way through the press, and therefore scaled a sycamore tree. There he was singled out by Jesus, who said to him, "Zacchaeus, make haste, and come down; for to-day I must abide at thy house" (ver 5). The offer thus frankly made by Jesus was accepted eagerly and gladly by Zacchaeus; and the murmurings of the crowd marred the happiness of neither. How completely the new birth was accomplished in Zacchaeus is testified by his vow to give half of his goods to the poor, and to make fourfold restitution where he had wrongfully exacted. The incident reveals the Christian truth that just as the publican Zacchaeus was regarded by the rest of the Jews as a sinner and renegade who was unworthy to be numbered among the sons of Abraham, and was yet chosen by Our Lord to be His host, so the social outcast of modern life is still a son of God, within whose heart the spirit of Christ is longing to make its abode. "For the Son of man came to seek and to save that which was lost" (ver 10).

(2) An officer of Judas Maccabaeus (2 Macc 10 19).

(3) A Zacchaeus is mentioned in the *Clementine Homilies* (iii.63) as having been a companion of St. Peter and appointed bishop of Caesarea.

(4) According to the Gospel of the Childhood, by Thomas, Zacchaeus was also the name of the teacher of the boy Jesus.

C. M. KERR

**ZACCUR**, zak'ur (זַכְּרִי, *zakkūr*, perhaps "ventriloquist" [Gray, *Nu*, 137]):

(1) Father of Shammua the Reubenite spy (Nu 13 4).

(2) A Simeonite (1 Ch 4 26); AV "Zacchur."

(3) Levites: (a) a Merarite (1 Ch 24 27); (b) a "son" of Asaph (1 Ch 25 2.10; Neh 12 35); (c) Neh 10 12 (Heb ver 13), and probably the same as in Neh 13 13, father of Hanan.

(4) A marginal reading in Ezr 8 14 for Zabbud where K<sup>o</sup>thibh is really "Zabud"; see ZABBUD.

(5) Son of Imri and one of the builders of Jerus (Neh 3 2).

DAVID FRANCIS ROBERTS

**ZACCHUR**, zak'ur. See ZACCUR.

**ZACHARIAH**, zak-a-rī'a (Ζαχαρίας, *Zacharias*; AV *Zacharias*):

(1) The son of Barachiah, who, Jesus says, was slain between the temple and the altar (Mt 23 35; Lk 11 51). The allusion seems to be to the murder of Zechariah, the son of Jehoiada (2 Ch 24 20 ff). In this case "Barachiah" would seem to be a gloss which has crept into the text through confusion with the name of the father of the prophet Zechariah, BERECHIAH (q.v.).

(2) See ZECHARIAH.

**ZACHARIAS**, zak-a-rī'as (Ζαχαρίας, *Zachartas*):

(1) One of the "rulers of the temple" at the time of Josiah's Passover. (1 Esd 1 8) = "Zechariah" of 2 Ch 35 8.

(2) One of the "holy singers" at Josiah's Passover (1 Esd 1 15); the name stands in place of "Heman" in 2 Ch 35 15.

(3) In 1 Esd 6 1; 7 3 = the prophet Zechariah.

(4) One of the sons of Pharos who returned with Ezra at the head of his family (1 Esd 8 30) = "Zechariah" of Ezr 8 3, and perhaps identical with (5).

(5) One of the "men of understanding" with whom Ezra consulted when he discovered the absence of priests and Levites (1 Esd 8 44) = "Zechariah" of Ezr 8 16, and perhaps identical with (6).

(6) Zacharias (om. in AV), who stood on Ezra's left hand as he expounded the Law (1 Esd 9 44) = "Zechariah" of Neh 8 4.

(7) One of the sons of Babi who went up at the head of his family with Ezra (1 Esd 8 37) = "Zechariah" of Ezr 8 11.

(8) One of the sons of Elam who had taken foreign wives (1 Esd 9 27) = "Zechariah" of Ezr 10 26.

(9) The father of Joseph, one of the "leaders of the people" under Judas (1 Macc 5 18.56).

(10) AV = RV "Zaraias" (1 Esd 5 8).

(11) AV = RV "Zachariah" of Mt 23 35.

S. ANGUS

**ZACHARIAS** (Ζαχαρίας, *Zachartas*): Father of John the Baptist (Lk 1 5, etc). He was a priest of the course of ABIJAH (q.v.), of blameless life, who in his old age was still childless. But on one occasion when it was the turn of the course of Abijah to minister in the temple (see TEMPLE), Zacharias was chosen by lot to burn incense. While engaged in this duty he was visited by Gabriel, who announced to him that he should become the father of the precursor of the Messiah. Zacharias received the promise incredulously and was punished by being stricken dumb. When, however, the child was born and Zacharias had obeyed the injunction of Gabriel by insisting on the name John, his powers of speech returned to him. According to Lk 1 67-79, Zacharias was the author of the hymn *Benedictus*, which describes God's deliverance of Israel in language drawn entirely from the O.T., and which is unaffected by the later Christian realization that the Kingdom is also for Gentiles.

Elisabeth, his wife, was of the daughters of Aaron (Lk 1 5) and kinswoman of the Virgin (1 36; the relationship is altogether obscure). According to 1 42-45, she was one of those who shared in the secret of the Annunciation. A few MSS in Lk 1 46 ascribe the *Magnificat* to her, but this seems certainly erroneous. See esp. Zahn, *Evangelium des Lucas*, 98-101 and 745-751 (1913).

BURTON SCOTT EASTON

**ZACHARY**, zak'a-ri (Lat *Zacharias*): AV and RV in 2 Esd 1 40 = the prophet Zechariah.

**ZACHER**, zā'kēr. See ZECHER.

**ZADOK**, zā'dok (זָדוּק, once זָדוּק, *zādōk* [1 K 1 26], similar to זָדוּק, *zādōk*, and זָדוּק, *zādōk*, post-Bib., meaning *justus*, "righteous"; LXX Ζαδῶκ,

*Saddōk*): Cheyne in *EB* suggests that *Z.* was a modification of a gentile name, that of the *Zidkites* in the Negeb, who probably derived their appellation from *צדק*, *gdk*, a secondary title of the god they worshipped. At the same time Cheyne admits that cultivated Israelites may have interpreted *Zadok* as meaning "just," "righteous"—a much more credible supposition.

(1) *Z.* the son of *Ahitub* (2 S 8 17)—not of *Ahitub* the ancestor of *Ahimelech* (1 S 14 3) and of *Abiathar*, his son (1 S 22 20).

(2) *Z.* father of *Jerusha*, mother of *Jotham*, and wife of *Uzziah* king of *Judah* (2 K 15 33; 2 Ch 27 1).

(3) *Z.* the son of *Ahitub* and father of *Shallum* (1 Ch 6 12) or *Meshullam* (Neh 11 11), and the ancestor of *Ezra* (7 1-2).

(4) *Z.* the son of *Baana*, a wall-builder in the time of *Nehemiah* (Neh 3 4), and probably one of the signatories to the covenant made by the princes, priests and Levites of *Israel* (Neh 10 21)—in both places his name occurring immediately after that of *Meshezabel*.

(5) *Z.* the son of *Immer*, and, like the preceding, a repairer of the wall (Neh 3 29).

(6) *Z.* a scribe in the time of *Nehemiah* (13 13). Whether this was the same as either of the two preceding cannot be determined.

The first of these filled a larger place in OT history than either of the others; and to him accordingly the following paragraphs refer. They set forth the accounts given of him first in *S* and *K* and next in *Ch*; after which they state and criticize the critical theory concerning him.

(1) In these older sources *Z.* first appears in *David's* reign, after *Israel* and *Judah* were united under him, as joint occupant with **1. In S** *Ahimelech* of the high priest's office, his name taking precedence of that of his colleague *Ahimelech*, the son of *Abiathar* (2 S 8 17).

(2) On *David's* flight from *Jerus*, occasioned by *Absalom's* rebellion, *Zadok* and *Abiathar* (now the joint high priest), accompanied by the whole body of the Levites, followed the king across the *Kidron*, bearing the *Ark of the Covenant*, which, however, they were directed to carry back to the city, taking with them their two sons, *Ahimaaz* the son of *Zadok*, and *Jonathan* the son of *Abiathar*, to act as spies upon the conduct of the rebels and send information to the king (2 S 15 24-36; 17 15.17-21).

(3) On the death of *Absalom*, *Z.* and *Abiathar* were employed by *David* as intermediaries between himself and the elders of *Judah* to consult about his return to the city, which through their assistance was successfully brought about (2 S 19 11).

(4) When, toward the end of *David's* life, *Adonijah* the son of *Haggith*, and therefore the crown prince, put forward his claim to the throne of all *Israel*, taking counsel with *Joab* and *Abiathar*, *Z.* along with *Benaiah*, the son of *Jehoiada*, and *Nathan* the prophet, espoused the cause of *Solomon*, *Bathsheba's* son, and acting on *David's* instructions anointed him as king in *Gihon* (1 K 1 8.26.32-45).

(5) Accordingly, when *Solomon* found himself established on the throne, he put *Z.* in the room of *Abiathar*, i.e. made him sole high priest, while retaining *Abiathar* in the priestly office, though deposed from a position of coördinate authority with *Z.* (1 K 2 26.27.35; 4 4).

(1) As in the earlier sources so in these, *Z.'s* father was *Ahitub* and his son *Ahimaaz*—the information being added that they were all descendants from *Aaron* through *Eleazar* (1 Ch 6 50-53).

(2) Among the warriors who came to *Hebron* to turn the kingdom of *Saul* to *David* was "*Z.*, a young man mighty of valor," who was followed by 22 captains of his father's house (1 Ch 12 26-28).

(3) Along with *Abiathar* and the Levites, *Z.* was directed by *David* to bring up the *Ark* from the

house of *Obed-edom* to the tent pitched for it on *Mt. Zion*, when *Z.* was appointed to officiate at *Gibeon*, while *Abiathar*, it is presumed, ministered in *Jerus* (1 Ch 15 11; 16 39).

(4) Toward the end of *David's* reign *Z.* and *Abimelech* the son of *Abiathar* acted as priests, *Z.* as before having precedence (1 Ch 18 16).

(5) To them was committed by the aged king the task of arranging the priests and Levites according to their several duties, it being intimated by the narrator that *Z.* was of the sons of *Eleazar*, and *Ahimelech* (in 18 16, named *Abiathar*; see above) of the sons of *Ithamar* (1 Ch 24 3). In ver 6 *Ahimelech* is called the son of *Abiathar*, while in 18 16, *Abiathar's* son is *Abimelech*—which suggests that the letters *b* and *h* were interchangeable in the name of *Abiathar's* sons.

(6) When *Solomon* was anointed king, *Z.* was anointed (sole) priest (1 Ch 29 22).

Obviously a large measure of agreement exists between the two narratives. Yet some points demand explanation.

**3. Harmony** (1) The seeming discrepancy between the statements in the earlier **Accounts** sources, that *Z.'s* colleague in the high priest's office is first named *Ahimelech* (2 S 8 17) and afterward *Abiathar* (2 S 15 24), should occasion little perplexity. Either *Ahimelech* and *Abiathar* were one and the same person—not an unlikely supposition (see above); or, what is more probable, *Abiathar* was *Ahimelech's* son and had succeeded to his father's office.

(2) *Z.'s* appearance as a young soldier among the captains who brought *David* to *Jerus* (assuming that *Z.* the soldier was *Z.* the priest, which is not absolutely certain) need create no difficulty, if *Z.* was not then of age to succeed his father in the priestly office. The earlier sources do not make *Z.* an acting priest till after *David's* accession to the throne of all *Israel*.

(3) Neither should it prove an insoluble problem to explain how, soon after *David's* accession to the throne of *Judah* and *Israel*, *Z.* should be found engaged along with *Abiathar* in bringing up the *Ark* to *Mt. Zion*, as by this time *Z.* had obviously entered on the high-priestly office, either in succession to or as colleague of his father.

(4) That *Z.* was left to officiate at *Gibeon* where the tabernacle was, while *Abiathar* was selected to exercise office in the capital, in no way conflicts with the earlier account and seems reasonable as a distribution of official duties. Why *Z.* was sent to *Gibeon*, where the tabernacle was, and not kept at *Jerus* whither the *Ark* had been brought, he being always named before *Abiathar* and probably looked upon as the principal high priest, may have had its reason either in the fact that the king regarded *Gibeon* as the central sanctuary for national worship, the tabernacle being there (*Solomon* obviously did; see 2 Ch 1 3), and therefore as the proper place for the principal high priest; or in the fact that *Z.* was younger than *Abiathar* and therefore less fitted than his older colleague to be at court, as an adviser to the king.

(5) That toward the end of *David's* reign, not *Abiathar*, but his son *Ahimelech* (or *Abimelech*), should be introduced as joint high priest with *Z.* will not be surprising, if *Abiathar* was by this time an old man, as his father was at the beginning of *David's* reign. That grandfather and grandson should have the same name is as likely to have been common then as it is today.

(6) That *Z.* should have been appointed sole high priest on *Solomon's* accession (1 Ch 29 22) is not inconsistent with the statement (1 K 4 4) that under *Solomon* *Z.* and *Abiathar* were priests.

Abiathar might still be recognized as a priest or even as a high priest, though no longer acting as such. The act of deposition may have affected his son Ahimelech as well, and if both father and son were degraded, perhaps this was only to the extent of excluding them from the chief dignity of high priest.

The higher criticism holds: (1) that the Z. of David's reign was not really an Aaronite descended from Eleazar through Ahitub, who was not Z.'s father but Ahimelech's (Gray in *EB*, art. "Ahitub"), but an adventurer, a soldier of fortune who had climbed up into the priest's office, though by what means is not known (Wellhausen, *GJ*, 145); (2) that up till Z.'s appearance the priesthood had been in Ithamar's line, though, according to the insertion by a later writer in the text of 1 S 2 (see vs 27 ff), in Eli's day it was predicted that it should pass from Eli's house and be given to another; (3) that when Abiathar or Ahimelech or both were deposed and Z. instituted sole high priest by Solomon, this fictitious prophecy was fulfilled—though in reality there was neither prophecy nor fulfillment; (4) that during the exile Ezekiel in his sketch of the vision-temple represented the Zadokites as the only legitimate priests, while the others of the line of A. were degraded to be Levites; (5) that in order to establish the legitimacy of Z. the writer of P invented his Aaronic descent through Eleazar and inserted the fictitious prophecy in 1 S.

(1) This theory proceeds upon the assumption, not that the Chronicler was a post-exilic writer (which is admitted), but that he deliberately and purposely idealized and to that extent falsified the past history of his people by ascribing to them a faithful adherence to the Levitical institutions of the PC, which, according to this theory, were not then in existence—in other words by representing the religious institutions and observances of his own age as having existed in the nation from the beginning. Were this theory established by well-accredited facts, it would doubtless require to be accepted; but the chief, if not the only, support it has is derived from a previous reconstruction of the sacred text in accordance with the theory it is called on to uphold.

(2) That the father of Z. was not Ahitub, a priest of the line of Eleazar, is arrived at by declaring the text in 2 S 8 17 to have been intentionally corrupted, presumably by a late R, the original form of the verse having been, according to criticism (Wellhausen, *TBS*, 176 f): "Abiathar the son of Ahimelech, the son of Ahitub, and Z. were priests." But if this was the original form of the words it is not easy to explain why they should have been so completely turned round as to say the opposite, viz. that Ahimelech was the son of Abiathar, and that Ahitub was the father of Z., when in reality he was the father of Ahimelech. If, as Cornill admits (*Eint*, 116), the Chronicler worked "with good, old historical material," it is not credible that he made it say the opposite of what it meant.

(3) If Z. was not originally a priest, but only a military adventurer, why should David have made him a priest at all? Wellhausen says (*GI*, 20) that when David came to the throne he "attached importance to having as priests the heirs of the old family who had served the Ark at Shiloh." But if so, he had Abiathar of the line of Ithamar at hand, and did not need to go to the army for a priest. If, however, it is urged that in making Z. a priest he gave him an inferior rank to Abiathar, and sent him to Gibeon where the tabernacle was, why should both sources so persistently place Z. before Abiathar?

(4) If Z. was originally a soldier not connected with the priesthood, and only became a priest after David came to Jerus, why should the earlier source have omitted to record this, when no reason existed, so far as one can discover, why it should have been left out? And why should the priestly disposed Chronicler have incorporated this in his narrative when all his inclinations should have moved him to omit it, more esp. when he was intending to invent (according to the critical theory) for the young warrior an Aaronite descent?

(5) That the prediction of the fall of Eli's house (1 S 2 27-36) was inserted by a late writer to justify its supersession by the line of Z. has no foundation except the presupposition that prediction is impossible, which fair-minded criticism cannot admit. The occurrence of the word "anointed," it is contended, presupposes the monarchy. This, however, it only predicts; and at the most, as Driver sees (*Intro*, 164), cannot prove the fictitious character of the prophecy, but merely that it has been "recast by the narrator and colored by the associations with which he himself is familiar"; and even this is entirely hypothetical.

(6) Ezekiel's reference to Z.'s descendants as the only legitimate priests in the vision-temple does not prove that Z. himself was a soldier who climbed up into the priesthood. Even if the critical interpretation of the vision-temple were correct, it in no way affects the per-

sonality of Z., and certainly does not disprove his original connection with the priesthood or his descent from Eleazar.

T. WHITELAW

**ZAHAM**, zā'ham (זָחָם, *zāham*, meaning uncertain; LXX A, Ζαλάμ, *Zalám*, B, Ῥοολλάμ, *Rhoollám*): A son of King Rehoboam (2 Ch 11 19).

**ZAIN**, zā'in. See ZAYIN.

**ZAIR**, zā'ir (צַיִר, *zā'ir*; Ζεῖρ, *Zeîr*): When he invaded Edom, we are told that Joram passed over to Zair and all his chariots with him (2 K 8 21). In the parallel passage (2 Ch 21 9), "with his captains" (צָרִי, *zā'ir*) takes the place of "to Zair" (צַיִר, *zā'ir*), probably a copyist's corruption. The place has not been identified. Some have thought that Mt. Seir is intended; others that it means the town of Zoar. Conder suggested *ez-Zuweirah*, S.E. of the Dead Sea. If Zoar lay in this direction, it is the way by which an invading army might enter Edom.

**ZALAPH**, zā'laf (צַלָּפ, *zālāph*, "caper-plant"): Father of Hanun, one of the repairers of the wall (Neh 3 30).

**ZALMON**, zal'mon (צַלְמוֹן, *zalmōn*; Σελμόν, *Selmōn*, ὄρος Ἐρμών, *oros Ermōn*; AV Salmon [Ps 68 14]):

(1) From the slopes of Mt. Zalmon, Abimelech and his followers gathered the wood with which they burned down "the stronghold of the house of Elberith," which may have been the citadel of Shechem (Jgs 9 46). The mountain therefore was not far from the city; but no name resembling this has yet been recovered in Mt. Ephraim. It is just possible that in the modern Arab. name of Mt. Ebal, *es-Sulēmīyeh*, there may be an echo of Zalmon. It is precisely to this mountain, esp. to the western slopes, that one would expect Abimelech and his people to go for the purpose in view. The name occurs again in Ps 68 14, a passage of admitted difficulty. Snow in Pal is mainly associated with Mt. Hermon, where it may be seen nearly all the year round; hence doubtless the Gr reading "Mt. Hermon" in Jgs. But snow is well known among the uplands in winter; and the Psalmist may simply have meant that the kings were scattered like snow-flakes in the wind on Mt. Zalmon. We need not therefore look to Bashan or elsewhere for the mountain. The locality is fixed by the narrative in Jgs.

(2) One of David's heroes (2 S 23 28). See ILAI.  
W. EWING

**ZALMONAH**, zal-mō'nā (צַלְמוֹנָה, *zalmōnāh*, "gloomy"): A desert camp of the Israelites, the first after Mt. Hor (Nu 33 41.42). The name "suggests some gloomy valley leading up to the Edomite plateau." See WANDERINGS OF ISRAEL.

**ZALMUNNAH**, zal-mun'a. See ZEBAH AND ZALMUNNA.

**ZAMBIS**, zam'bis: AV=RV ZAMBRI (q.v.).

**ZAMBRI**, zam'brī (B, Ζαμβρεῖ, *Zambrei*, A, Ζαμβροῖς, *Zambrois*; AV *Zambis*, from Aldine Ζαμβροῖς, *Zambrois*):

(1) One of the sons of Ezora who put away their foreign wives (1 Esd 9 34)—"Amariah" of Ezr 10 42.

(2) AV=RV "Zimri" of 1 Macc 2 26.

**ZAMOTH**, zā'moth, zā'mōth (Ζαμόθ, *Zamōth*): The head of a family, some members of which married foreign wives (1 Esd 9 28)—"Zattu" of

Ezr 10 27; called "Zathui" in 1 Esd 5 12 and "Zathoes" (AV "Zathoe") in 8 32.

**ZAMZUMMIM**, zam-zum'im (זַמְזוּמִים, zam-zummim): A race of giants who inhabited the region E. of the Jordan afterward occupied by the Ammonites who displaced them. They are identified with the Rephaim (Dt 2 20). They may be the same as the Zuzim mentioned in connection with the Rephaim in Gen 14 5. See REPHAIM.

**ZANOAH**, za-nō'a (זַנּוֹאִי, zānō'h; B, Tavo, Tano, A, Zavo, Zano):

(1) A town in the Judaean Shephelah, grouped with Eshtaol, Zorah and Ashnah (Josh 15 34). The Jews reoccupied the place after the exile (Neh 11 30). Here it is named between Jarmuth and Adullam. The inhabitants assisted in rebuilding the walls of Jerus, repairing the valley gate (Neh 3 13). *Onom* places it at Zanna, in the district of Eleutheropolis on the Jerus road. It is represented by the modern *Zanu'a*, about 10 miles N. of *Beit Jibrin* (Eleutheropolis).

(2) (B, Ζακαναεῖμ, *Zakanaeīm*, A, Zavo, Zano): A place in the mountains (Josh 15 56) of which Jekuthiel was the "father" or founder (1 Ch 4 18). It may be identified with *Zenūtā*, a ruined site on a hill about 12 miles S. of Hebron. W. EWING

**ZAPHENATH-PANEAH**, zaf-ē'nath-pa-nē'a, **ZAPHNATH-PAANEAH**, zaf'nath-pā-a-nē'a (זַפְנַת־פַּאנְיָה, zāph'nath pa'ānē'h; Egyp *Zoph-ent-pa-anēh*; LXX D, Ψονθοφανήχ, *Psonthomphanēch*, "the one who furnishes the nourishment of life," i.e. the chief steward of the realm): The name given Joseph by the Egyp king by whom he was promoted, probably the Hyksos king Aphonis (Gen 41 45). See JOSEPH.

**ZAPHON**, zā'fon (זַפְחֹן, zāphōn; B, Ζαφών, *Saphān*, A, Ζαφών, *Saphōn*): A city on the E. of the Jordan in the territory of Gad (Josh 13 27). It is named again in Jgs 12 1 as the place where the elders of Gilead gathered to meet with Jephthab (zāphōnāh should be tr'd "to Zaphon," not "northward"). It must have lain well to the N. of Gad. According to the Talm Amathus represented Zaphon (Neubauer, *Géog. du Talm*, 249). Here sat one of the Synedria created by Gabinius (*Ant*, XIV, v, 4). It was a position of great strength (*BJ*, I, iv, 2). *Onom* places it 21 Rom miles S. of Pella. This is the modern *Tell 'Amāteh*, on the south bank of *Wādy er-Rujeib*, 15 miles S. of Pella, and nearly 5 miles N. of the Jabbok. Buhl (*GAP*, 259) objects to the identification that *Tell 'Amāteh* corresponds to the Asophon of Jos (*Ant*, XIII, xii, 5). But this objection does not seem well founded. W. EWING

**ZARA**, zā'ra (Ζαρά, *Zarā*): AV (Mt 1 3)=Gr form of ZERAH (q.v.).

**ZARACES**, zar'a-sēz: AV=RV ZARAKES (q.v.).

**ZARAH**, zā'ra. See ZERAH, (1).

**ZARAIAS**, za-rā'yas, za-rī'as (Ζαράϊας, *Zaraias*):

(1) One of the leaders in the Return along with Zerubbabel (1 Esd 5 8)="Seraiiah" of Ezr 2 2 and "Azariah" of Neh 7 7=AV ZACHARIAS (q.v.).

(2) An ancestor of Ezra in 1 Esd 8 2 (omitted in B and Swete)="Zerahiah" of Ezr 7 4 and apparently="Arna" of 2 Esd 1 2.

(3) The father of Eliaonias, the leader of the sons of Phaath Moab under Ezra (1 Esd 8 31)="Zerahiah" of Ezr 8 4.

(4) One of "the sons of Saphatias" who went up with Ezra (1 Esd 8 34)="Zebadiah" of Ezr 8 8.

**ZARAKES**, zar'a-kēz (A and Fritzsche, Ζαράκης, *Zarākēs*, B and Swete, Ζάριος, *Zários*; Vulg *Zaracelem*; AV *Zaraces*): Occurs in the difficult passage, 1 Esd 1 38, as the equivalent of Jehoahaz (2 K 23 34) and Joahaz (2 Ch 36 4), the brother of Eliakim (Jehoiakim or JOAKIM [q.v.]). According to 1 Esd 1 38, Joakim apparently apprehended his brother, Zarakes, and brought him up out of Egypt, whither he must have been previously taken by Necho, whereas 2 K and 2 Ch only state that Necho took Joahaz (Zarakes) to Egypt.

**ZARDEUS**, zār-dē'us (A, Ζαρδάτας, *Zardatas*, B, Swete and Fritzsche, Ζεραλίαις, *Zeralias*; AV *Sardeus*): One of the sons of Zamoth who had married "strange wives" (1 Esd 9 28)="Aziza" of Ezr 10 27.

**ZAREAH**, zā'rē-a, za-rē'a (זַרְעָה, zōr'āh): AV in Neh 11 29 for ZORAH (q.v.).

**ZAREATHITES**, za-rē'a-thīts. See ZORATHITES.

**ZARED**, zā'red (זָרֵד, zāredh [in pause]). See ZERED.

**ZAREPHATH**, zar'ē-fath (זַרְפָּת, zār'phath; Σάρεπτα, *Sārepta*): The Sidonian town in which Elijah was entertained by a widow after he left the brook Cherith (1 K 17 9 ff). Obadiah refers to it as a Can. (probably meaning Phoen) town (ver 20). It appears in the Gr form *Sarepta* in Lk 4 26 (AV), and is said to be in the land of Sidon. Jos (*Ant*, VIII, xiii, 2) says it was not "far from Sidon and Tyre, for it lay between them." *Onom* (s.v. "Sarefta") places it on the public road, i.e. the road along the seashore. It can be no other than the modern *Sarafend*, about 13 miles N. of Tyre, on the spur of the mountain which divides the plain of Tyre from that of Sidon.

The site of the ancient town is marked by the ruins on the shore to the S. of the modern village, about 8 miles to the S. of Sidon, which extend along the shore for a mile or more. They are in two distinct groups, one on a headland to the W. of a fountain called *Ain el-Kantara*, which is not far from the shore. Here was the ancient harbor which still affords shelter for small craft. The other group of ruins is to the S., and consists of columns, sarcophagi and marble slabs, indicating a city of considerable importance. The modern village of *Sarafend* was built some time after the 12th cent., since at the time of the Crusades the town was still on the shore.

It is conjectured that the Syrophoenician woman mentioned in Lk 4 26 was an inhabitant of Z., and it is possible that Our Lord visited the place in His journey to the region as narrated in Mk 7 24-31, for it is said that he "came through Sidon unto the sea of Galilee."

The place has been identified by some with *Misrephoth-maim* of Josh 11 8 and 13 6, but the latter passage would indicate that *Misrephoth-maim* was at the limit of the territory of the Sidonians, which Z. was not in the days of Joshua. See MISREPHOTH-MAIM; SIDON.

Originally Sidonian, the town passed to the Tyrians after the invasion of Shalmaneser IV, 722 BC. It fell to Sennacherib 701 BC. The *Wely*, or shrine bearing the name of *el-Khudr*, the saint in whom St. George is blended with Elijah, stands near the shore. Probably here the Crusaders erected a chapel on what they believed to be the site of the widow's house. W. EWING

**ZARETAN**, zar'ē-tan (זַרְעָתַן, zār'ethān): AV Josh 3 16 for ZARETHAN (q.v.).

**ZARETHAN**, zar'ê-than (זָרְתָּן, *zâr'thân*): A city, according to Josh 3 16 (omitted, however, by LXX) near Adam, which is probably to be identified with *Tell Dâmieh* at the mouth of the Jabbok. In 1 K 4 12 it is mentioned in connection with Bethshean and said to be "beneath Jezreel." In 1 K 7 46, this is said to be at "the ford of Adamah," according to the reading of some, but according to the Massoretic text, "in the clay ground between Succoth and Zarethan," where the bronze castings for the temple were made by Solomon's artificers. In 2 Ch 4 17, the name appears as *Zeredah*, which in 1 K 11 26 is said to have been the birthplace of Jeroboam, son of Nebat. In Jgs 7 22, Gibeon is said to have pursued the Midianites "as far as Bethshittah toward *Zererah*," which is probably a misreading for *Zeredah*, arising from the similarity of the Heb letters *dâleth* and *rêsh*. The place has not been positively identified. From the suggestion that the name means "the great [or lofty] rock," it has without sufficient reason been supposed that it designates the conspicuous peak of *Kurn Surtabeh*, which projects from the mountains of Ephraim into the valley of the Jordan opposite the mouth of the Jabbok.

GEORGE FREDERICK WRIGHT

**ZARETH-SHAHAR**, zâ'reth-shâ'hâr (זָרְתָּן שָׁהָר, *zêreth ha-shahar*). See **ZERETH-SHAHAR**.

**ZARHITES**, zâr'hits. See **ZERAH**, (1), (4).

**ZARTANAH**, zâr-tâ'na, zâr'tâ-nâ (זָרְתָּנָה, *zâr'thanâh*): AV in 1 K 4 12 for "Zarethan." The form is Zarethan with Hê locale.

**ZARTHAN**, zâr'than (זָרְתָּן, *zâr'thân*): AV in 1 K 7 46 for **ZARETHAN** (q.v.).

**ZATHOES**, zath'ô-êz, za-thô'êz (Ζαθοῦς, *Zathoês*; AV *Zathoe*): Name of a family, part of which returned with Ezra (1 Esd 8 32), not found in the Heb of Ezr 8 5; probably identical with "Zattu" of Ezr 2 8; Neh 7 13, many of which family went up with Zerubbabel, and so called also "Zathui" (1 Esd 5 12). See **ZATTU**.

**ZATHUI**, za-thû'î (Ζαθουί, *Zaththouí*, LXX B, Ζατόν, *Zatón*): In 1 Esd 5 12="Zattu" in Ezr 2 8; Neh 10 14. In 1 Esd 9 28 the same name is "Zamoth."

**ZATTHU**, zat'thû: In Neh 10 14; RV **ZATTU** (q.v.).

**ZATTU**, zat'û (זַטְו, *zattû*, meaning unknown): Head of a large family that returned with Zerubbabel to Jerus from Babylon (Ezr 2 8; 10 27; Neh 7 13; 10 14 [15]). According to Ezr 10 27, some of his sons had married foreign wives, and Zattu is named in Neh 10 14 as one of the chiefs who signed Nehemiah's covenant. LXX A also adds the name before that of Shecaniah in Ezr 8 5, and so we should read, "And of the sons of Zattu, Shecaniah . . ."; so 1 Esd 8 32 has Ζαθοῦς, *Zathoês*. AV has "Zatthu" in Neh 10 14.

**ZAVAN**, zâ'van. See **ZAAVAN**.

**ZAYIN**, zâ'yin (ז): The 7th letter of the Heb alphabet; transliterated in this Encyclopaedia as z. It came also to be used for the number 7. For name, etc, see **ALPHABET**.

**ZAZA**, zâ'za (זָזָא, *zâzâ*, meaning unknown; LXX B, Ὀζάμ, *Ozám*, A, Ὀζαζά, *Ozazá*): A Jerahmeelite (1 Ch 2 33).

**ZEALOT**, zel'ut, **ZEALOTS**, zel'nts: Simon, one of the apostles, was called "the Zealot" (Ζηλωτής, *Zēlōtēs*, from ζήλω, *zēlō* "to rival," "emulate," "be jealous," "admire," "desire greatly," Lk 6 15; Acts 1 13, AV "Zealotes"). In Mt 10 4 and Mk 3 18 he is called "the Cananaean" (so RV correctly; not "the Canaanite," as AV says, following inferior MSS), ὁ Καναναῖος, *ho Kananaïos*. From the time of the Maccabees there existed among the Jews a party who professed great zeal for the observance of the "law." According to Jos (*BJ*, IV, iii, 9; v, 1; VII, viii, 1) they resorted to violence and assassination in their hatred of the foreigner, being at many points similar to the Chinese Boxers. It is not improbable that the "Assassins" (see **ASSASSINS**) of Acts 21 38 were identical, or at least closely associated, with this body of "Zealots," to which we must conclude that Simon had belonged before he became one of the Twelve. See, further, **SIMON THE ZEALOT**.

WILLIAM ARTHUR HEIDEL

**ZEBADIAH**, zeb-a-dī'a ([זְבַדְיָהוּ, *zēbadhyāhū*, [2] זְבַדְיָה, *zēbadhyāh*, "Jeh has bestowed"; the form [1] is the Heb name in [1], [a], [b], [2], below; the form [2] in the rest. Some MSS have "Zechariah" in [1], [a], [b], [3]; cf **ZABDI**; **ZABDIEL**):

(1) Levites: (a) a Korahite doorkeeper of David's reign (1 Ch 26 2); (b) one of the Levites sent by King Jehoshaphat to teach the *Tōrah* in Judah (2 Ch 17 8).

(2) Son of Ishmael (2 Ch 19 11); "ruler of the house of Judah in all the king's [Jehoshaphat's] matters," i.e. judge in civil cases, the "controversies" of ver 8.

(3) Benjamites, perhaps descended from Ehud (see Curtis, *Chron.*, 158 ff): (a) In 1 Ch 8 15; (b) in ver 17, where the name may be a dittography from ver 15.

(4) A Benjamite recruit of David at Ziklag (1 Ch 12 7 [Heb ver 8]).

(5) One of David's army officers, son and successor of Asahel (1 Ch 27 7).

(6) One of those who returned from Babylon to Jerus with Ezra (Ezr 8 8)="Zaraias" of 1 Esd 8 34.

(7) One of those who had married foreign wives (Ezr 10 20)="Zabdeus" of 1 Esd 9 21.

DAVID FRANCIS ROBERTS

**ZEBAH**, zē'ba (זִבְהָ, *zēbah*, "victim"), AND **ZALMUNNA**, zal-mun'a (צַלְמוֹנָה, *zalmunnā*, "protection refused"): Two Midianite kings or chiefs whom Gideon slew (Jgs 8 4-21; Ps 83 11 [Heb ver 12]). The name *zēbah* (Ζέβη, *Zēbee*) is very much like that of zē'ēbh (Zēb, *Zēb*, "Zeeb" in LXX). Moore (*Jgs*, 220) says that *zalmunnā* is probably "a genuine Midianite name"; Nöldeke conjectured that it contains that of a deity (צַלְמִ, *z[al]m*), and a compound form צַלְמִשׁוֹב, *zalmshzbbh*, is found in an inscription from Teimā, a place E. of the Midianite capital (*CIS*, II, cxiii f).

The narrative of Jgs 8 4-21 is not to be connected with that of 8 1-3. Budde (*Kurzer Hand-Comm. z. AT*, XXII) would join 8 4 to 6 34; Moore (*ICC*) following Budde's earlier work (1890) would connect it with a part of 7 22b, describing the direction of the fight, while Nowack (*Hand-Komm.*) regards the battle of 8 11 as the same as that of 7 11 ff; he then takes the latter part of 8 11 to refer to the place of the camp at night. There are many difficulties in forming a natural connection for the verses. It may be noted that in 8 18 f Gideon is not "the least in my father's house," as he represents himself to be in 6 15.

The whole section tells of a daring raid made by Gideon upon the Midianites. Some of his own kin had been slain by Midianite hordes at Ophrah (8 18 f), and, stirred by this, Gideon went in hot pursuit with 300 men (ver 4). He requested provisions for his men from the people of Succoth and Pennel, but was refused this. He then went on and caught

the Midianites unawares at Karkor (ver 10) and captured their two chiefs. He then had his revenge on the two towns, and returned probably to his home with the two notable prisoners. These he determined to slay to avenge the death of his own kinsmen, and called upon his eldest son to perform this solemn public duty that he owed to the dead. His son, apparently only a boy, hesitated, and he did the deed himself. W. R. Smith (*Lectures on the Rel. of the Sem.*, 2d ed, 417, n.) compares with this call to Gideon's son the choice of young men or lads as sacrificers in Ex 24 5, and says that the Saracens also charged lads with the execution of their captives.

The narrative reminds one of David's romantic life in 1 S 25, 27, 30. It is throughout a characteristic picture of the life of the early Hebrews in Pal, for whom it was a sacred duty to avenge the dead. It affords a splendid illustration of what is meant by the spirit of Jeh coming upon, or rather "clothing itself with" (RVm) Gideon (6 34); cf also Saul's call to action (1 S 11 1-11), and also Jgs 19 f.

DAVID FRANCIS ROBERTS

**ZEBAIM**, zê-hâ'im. See **POCHERETH-HAZZEBAIM**.

**ZEBEDEE**, zeb'ê-dê (זְבִידִי, *zibhîdî*, "the gift of God"; Ζεβεδάιος, *Zebedaios*): The father of the apostles James and John (Mk 1 19) and a fisherman on the Sea of Galilee (Mk 1 20), the husband of Salome (Mt 27 56; cf Mk 16 1). See **JAMES, SON OF ZEBEDEE**; **SALOME**.

**ZEBIDAH**, zê-bî'da, zeb'i-da (זְבִידָה, i.e. זְבִידָה, *z'bhîdâh*, K'rê, whence AV "Zebudah," whereas K'thîbh is זְבִידָה, *z'bhîdâh*; the K'rê means "bestowed" and is the fem. of Zabud): Daughter of Pedaiah of Rumah, and mother of King Jehoiaikim of Judah (2 K 23 36). LXX B has, however, Ἰελλὰ θυγάτηρ Ἐδεῖλ ἐκ Κρουμά, *Iellâ thugâtêr Edêil ek Kroumâ*, A, Εἰλεδάφ θ. Εἰλεδίλα ἐκ Ρουμά, *Eiêldâph th. Eïêddîlâ ek Rhumâ*. In 2 Ch 36 5 MT lacks these names, but LXX B has Ζεχωρά θ. Νηπέου ἐκ Ραμά, *Zechorâ th. Nêreïou ek Rhamá*; here the name of the king's mother = Heb זְבִידָה, *z'bhîdâh*, due to a confusion of כ with ב (k and b) and ר with ד (r and d), and thus we find support for the K'rê *z'bhîdâh* ("Zebudah," in 2 K 23 36 AV). Luc. has confused the names here with those of 2 K 24 18, and has as there, "Amital, the daughter of Jeremiah of Libnah." DAVID FRANCIS ROBERTS

**ZEBINA**, zê-bî'na (זְבִינָה, *z'bhî'nâ'*, "bought"): One of those who had married foreign wives (Ezr 10 43); the name is not in 1 Esd 9 35, and is omitted by LXX A in Ezr.

**ZEBOIM**, zê-boi'im (זְבוִיִּם, *z'bhōyîm*; LXX uniformly Ζεβωίμ, *Zebōeîm*; AV **Zeboim**): One of the cities in the Vale of Siddim, destroyed with Sodom and Gomorrah. It is always mentioned next to Admah (Gen 10 19; 14 2.8; Dt 29 23; Hos 11 8). It is not to be confounded with Zeboim mentioned in 1 S 13 18 and Neh 11 34. The site has not been positively identified, but must be determined by the general questions connected with the Vale of Siddim. See **SIDDIM, VALE OF**.

**ZEOIM**, zê-bō'im ([1] זְבוִיִּם, *z'bhōyîm*; Ζεβωίμ, *Sebōeîm* [Neh 11 34]; [2] גֵּי הַצְּבִיעִים, *gê ha-z'vîeîm*; Γαί τῆν Σαμελν, *Gaî tēn Samelēn* [1 S 13 18]):

(1) A Benjamite town mentioned as between **HADID** (q.v.) and **NEBALLAT** (q.v.), and therefore in the maritime plain near Lydda; the site is lost (Neh 11 34). (2) The Valley of Zeboim, "the valley of

hyenas," one of three companies of the Philistines left their camp at Michmah and "turned the way of the border that looketh down upon the valley of Zeboim toward the wilderness" (1 S 13 18). There are several valleys with names derived from the hyena, so common in these parts. There is a small branch valley called *Shakkeḏ qab'ā*, "ravine of the hyenas," N. of the *Wādy kelt* (Grove), a *Wādy abu qab'ā*, "valley of the father of hyenas," which joins the *Wādy kelt* from the S. (*Marti*), and a large and well-known *Wādy qab'ā*, "valley of hyenas," which runs parallel with the *Wādy kelt*, some 3 miles farther S., and ends at the Dead Sea. The first of these, which apparently leads to *Mukhmās* itself, seems the most probable. See *Conder's Handbook*, 241. E. W. G. MASTERMAN

**ZEBUDAH**, zê-bū'da. See **ZEBIDAH**.

**ZEBUL**, zê'bul (זְבֻל, *z'bhul*, perhaps "exalted"; Ζεβούλ, *Zeboul*): In Jgs 9 26 ff. He is called in ver 30 *sar hā-'ir*, "the ruler of the city," a phrase tr'd "the governor of the city" in 1 K 22 26=2 Ch 18 25; 2 K 23 8; 2 Ch 34 8; he was "commandant of the town" of Shechem. In ver 28 he is referred to as the *pākîdîh*, "officer," or, more correctly, "deputy" of Abimelech. This verse is a little difficult, but if we read "served" for "serve ye," it becomes fairly clear in meaning. With Moore (*Jgs*, 255 ff) we may translate it thus: "Who is Abimelech? and who is Shechem, that we should serve him [i.e. Abimelech]? Did not the son of Jerubbaal and Zebul his deputy [formerly] serve the people of Hamor [the father of Shechem]? Why then should we serve him [Abimelech]?" This is also the way Budde (*Kurzer Hand-Comm. z. AT*, 75) takes the verse. And further in ver 29 for "and he said" many read with LXX "then would I say."

The position of Zebul is here that of a deputy to Abimelech, who lived in Arumah (ver 41). When Gaal came to Shechem, a newcomer with a band of men, he seized the opportunity at a vintage feast to attack Abimelech and express a desire to lead a revolt against him (vs 26-29). Zebul heard these words and reported the matter to his master, advising him to make a sudden rush upon the city (vs 30-33). This Abimelech does, and Gaal, on noticing the troops, tells Zebul, who turns upon him and bids him make good his bragging words. Gaal is thus forced to go out and fight Abimelech, and is defeated (vs 34-40).

If this be the correct interpretation of the narrative so far, it is fairly simple and clear. Some, however, maintain that the words of Gaal about Zebul in ver 28 are meant as an insult to the governor of the city; this is the view of Wellhausen (*Compos.*, 353 f, n.) and Nowack (*Handkomm.*; cf also his *Archäologie*, I, 304, 308, for the meaning of *sar*). Zebul is, according to them, head of the Shechemite community, and Wellhausen and Kittel (*Hist of Heb.*, II, 85) believe him to have had something to do with the revolt of 9 23-25. For the latter view there is no proof; possibly Zebul was the head of the community of Shechem, but as he was a subject of Abimelech, who was the king or prince of Shechem, there could not be much sting in calling him the "deputy" of his master.

The questions that arise from vs 41 ff need only be referred to here. Many critics have seen in 9 23-45 more than one source. Moore groups the verses thus: (1) vs 22-23.25.42 ff as due to E, with ver 24 from R<sup>1</sup>E; (2) vs 26-41 due to J. It is doubtful if the division is as clear as this. There seem however to be parallels: (1) The plans of Abimelech in vs 34-40 are very similar to those in 42 ff. (2) Ver 41b seems to give in short what we find related in vs 34-40. (3) LXX in 9 31 has suggested to many that we should read there, "and he sent messengers unto Abimelech in Arumah," instead of reading "craftily." We would thus have a parallel to ver 41a. It may be suggested therefore that if the account be double (and it is strange that Abimelech should again attack the city by almost the same methods as before, when the revolters had been already got rid of), the narratives would be in this order:

Introductory, 9 23-25; then vs 26-29.30 common to both, and so possibly part of vs 31 and 32 f. Then we have two accounts of the event: (a) vs 31 (part).34-40; (b) vs 41-45, followed by vs 46 ff.

DAVID FRANCIS ROBERTS  
ZEBULONITE, zeb'û-lon-it. See ZEBULUNITES.

ZEBULUN, zeb'û-lun (זְבֻלֹן, *zēbhūlōn*, also written זְבֻלֵן and זְבֻלִין; the first form occurs only in Jgs 1 30; the other two are frequent, and are used interchangeably; Ζαβουλών, *Zaboulōn*): In Gen 30 20 Leah exclaims, "God hath endowed me with a good dowry," which suggests a derivation of Zebulun from *zābhadh*, "to bestow," the ז (d) being replaced by ל (l). Again she says, "Now will my husband dwell with me [or "honor me"]: and she called his name Zebulun"; the derivation being from *zābhal*, "to exalt" or "honor" (*OHL*, s.v.).

Zebulun was the 10th son of Jacob, the 6th borne to him by Leah in Paddan-aram. Nothing is known of this patriarch's life, save in so far as it coincides with that of his brethren. Tg Pseudojon says that he first of the five brethren was presented to Pharaoh by Joseph, when Israel and his house arrived in Egypt (Gen 47 2). Three sons, Sered, Elon and Jahleel, were born to him in Canaan, and these became the ancestors of the three main divisions of the tribe (Gen 46 14).

The position of the tribe of Zebulun in the wilderness was with the standard of the camp of Judah on the east side of the tabernacle (Nu 2 7). This camp moved foremost on the march (ver 9). At the first census Zebulun numbered 57,400 men of war (1 30), the prince of the tribe being Eliab, son of Helon (ver 9). At the second census the men of war numbered 60,500 (Nu 26 27); see, however, NUMBERS. Among the spies Zebulun was represented by Gaddiel son of Sodi (13 10). To assist in the division of the land Elizaphan son of Parnach was chosen (34 25). At Shechem Zebulun, the descendants of Leah's youngest son, stood along with Reuben, whose disgrace carried with it that of his tribe, and the descendants of the sons of the handmaids, over against the other six, who traced their descent to Rachel and Leah (Dt 27 13). At the second division of territory the lot of Zebulun came up third, and assigned to him a beautifully diversified stretch of country in the N. The area of his possession is in general clear enough, but it is impossible to define the boundaries exactly (Josh 19 10-16). It "marched" with Naphtali on the E. and S.E., and with Asher on the W. and N.W. The line ran northward from Mt. Tabor, keeping on the heights W. of the Sea of Galilee, on to *Kefr 'Anān* (Hannathon). It turned westward along the base of the mountain, and reached the border of Asher, probably by the vale of *'Abūlūn*. It then proceeded southward to the Kishon opposite *Tell Kaimūn* (Jokneam). As the plain belonged to Issachar, the south border would skirt its northern edge, terminating again at Tabor, probably near *Debūriyeh* (Daberath), which belonged to Issachar (21 28).

The details given are confusing. It is to be observed that this does not bring Zebulun into touch with the sea, and so is in apparent contradiction with Gen 49 13, and also with Jos (*Am*, V, 1, 22; *EJ*, III, iii, 1), who says the lot of Zebulun included the land which "lay as far as the Lake of Gennesareth, and that which belonged to Carmel and the sea." Perhaps, however, the limits changed from time to time. So far as the words in Gen 49 13 are concerned, Delitzsch thinks they do not necessarily imply actual contact with the sea; but only that his position should enable him to profit by maritime trade. This it certainly did; the great caravan route, *via maris*, passing through his territory. Thus he could "suck the treasures of the sea." See also TABOR, MOUNT. Within the boundaries thus roughly indicated were all varieties of mountain and plain, rough upland country, shady wood and fruitful valley. What is said of the territory of Naphtali applies generally to this.

Olive groves and vineyards are plentiful. Good harvests are gathered on the sunny slopes, and on the rich levels of the Plain of Asochis (*el-Battāuf*).

Elon the Zebulunite was the only leader given by the tribe to Israel of whom we have any record (Jgs 12 11 f); but the people were brave and skilful in war, furnishing, according to the Song of Deborah, "[them] that handle the marshal's staff" (5 14). The tribe sent 50,000 single-hearted warriors, capable and well equipped, to David at Hebron (1 Ch 12 33). From their rich land they brought stores of provisions (ver 40). Over Zebulun in David's time was Ishmaiah, son of Obadiah (27 19). Although they had fallen away, Hezekiah proved that many of them were capable of warm response to the appeal of religious duty and privilege (2 Ch 30 10 f.18 ff). They are not named, but it is probable that Zebulun suffered along with Naphtali in the invasion of Tiglath-pileser (2 K 15 29). In later days the men from these breezy uplands lent strength and enterprise to the Jewish armies. Jotapata (*Tell Jifāt*), the scene of Josephus' heroic defence, was in Zebulun. So was Sepphoris (*Seffūriyeh*), which was for a time the capital of Galilee (*Ant*, XVIII, ii, 1; *BJ*, VII; III, ii, 4). Nazareth, the home of our Saviour's boyhood, is sheltered among its lower hills.

W. EWING

ZEBULUNITES, zeb'û-lun-its (הַזְבֻּלֹנִי, *ha-zēbhūlōnī*; Ζαβουλών, *Zaboulōn*): Members of the tribe of Zebulun (Nu 26 27; Jgs 12 11 f).

ZECHARIAH, zek-a-rī'a (זְכַרְיָה, *zēkharyāhū*, or זְכַרְיָה, *zēkharyāh*; LXX Ζαχαρία[s], *Zacharia[s]*): A very common name in the OT. The form, esp. the longer form, of the name would suggest for its meaning, "Jeh remembers" or "Jeh is renowned," and the name was doubtless understood in this sense in later times. But the analogies with ZACCUR, ZECHEH, ZICHRI (q.v.), etc, make some original ethnic derivation probable.

(1) King of Israel, son of Jeroboam II (AV "Zachariah"). See next article.

(2) The grandfather of King Hezekiah, through Hezekiah's mother Abi (2 K 18 2, AV "Zachariah" || 2 Ch 29 1).

(3) A contemporary of Isaiah, taken by Isaiah as a trustworthy witness in the matter of the sign Maher-shalal-hash-baz (Isa 8 1). As his father's name was Jeberechiah, some support seems to be offered to the theories of those who would make him the author of certain portions of Zec. But see ZECHARIAH, BOOK OF.

(4) A Reubenite of the time of Israel's captivity (1 Ch 5 7).

(5) A Benjamite, living in Gideon (1 Ch 9 37; called "Zecher" in 8 31). He was the brother of Kish and hence the uncle of Saul.

(6) A Manassite of Gilead, at the time of David (1 Ch 27 21).

(7) The third son of Jehoshaphat (2 Ch 21 2). He was slain by Jehoram (ver 4).

(8) A "prince" whom Jehoshaphat sent to "teach" in the cities of Judah (2 Ch 17 7). As this "teaching" was in connection with the establishing of the Law, Zechariah was primarily a judge.

(9) A prophet who was influential in the early days of Uzziah (2 Ch 26 5). He is characterized as *hā-mēbh in bir'ōth (byir'ath?) hā-ēlōhīm*, which phrase is usually understood to mean that he had instructed (RVm) the king in the fear of God. As long as he lived the king profited by his instruction and advice.

The following eight are all Levites:

(10) A doorkeeper at the time of David, who was made a singer "of the second degree" (1 Ch 15 18;

the text is confused). He was a player on a "psaltery" (ver 20) and took part in the thanksgiving when the Ark was brought to Jerus (16 5).

(11) A son of Isshiah (1 Ch 24 25).

(12) A son of Meshelemlah, a "porter of the door of the tent of meeting" at the time of David (1 Ch 9 21; 26 2.14). In 26 14 called "a discreet counsellor."

(13) A son of Hosah, a Merarite, also at David's time (1 Ch 26 11).

(14) The father of the prophet, JAHAZIEL (q.v.) (2 Ch 20 14).

(15) A son of Asaph, who assisted in the purification of the Temple at the time of Hezekiah (2 Ch 29 13).

(16) A Kohathite, who assisted in the repair of the Temple at the time of Josiah (2 Ch 34 12).

(17) A son of Jonathan, an Asaphite, one of the musicians at the dedication of the wall at the time of Nehemiah (Neh 12 35).

The following are all priests:

(18) A trumpeter at the time of David (1 Ch 15 24).

(19) A son of Jehoiada, at the time of Joash. He rebuked the people publicly for their apostasy, and was stoned by them, Joash consenting to their act (2 Ch 24 20-22). As 2 Ch is the last book in the Heb OT, Zechariah was regarded as the last of the OT martyrs, and hence is coupled with Abel (the first martyr) in Mt 23 35 || Lk 11 51. The words "son of Barachiah" in Mt are due to confusing this Zechariah with the prophet. See ZACHARIAH.

(20) One of the "rulers of the house of God" at the time of Josiah (2 Ch 35 8).

(21) A son of Pashhur, 242 of whose descendants as "chiefs of fathers' houses" dwelt in Jerus at the time of Nehemiah (Neh 11 13).

(22) A trumpeter at the dedication of the wall at the time of Nehemiah (Neh 12 41).

(23) The prophet (Ezr 5 1; 6 14; Neh 12 16; Zec 1 1.7; 7 1.8; 1 Esd 6 1; 7 3). See ZACHARIAH, BOOK OF.

The following are all returned exiles or are mentioned only as ancestors of such:

(24) A son of Parosh (Ezr 8 3; 1 Esd 8 30 has "Zacharias" here and elsewhere).

(25) A son of Behai (Ezr 8 11; 1 Esd 8 37).

(26) One of the "chief men" dispatched by Ezra to bring priests from Casiphia (Ezr 8 16; 1 Esd 8 44). Doubtless the same as (24) or (25), above.

(27) One of the persons who stood by Ezra at the reading of the Law (Neh 8 4; 1 Esd 9 44); almost certainly identical with (26).

(28) A son of Elam, who had taken a foreign wife (Ezr 10 26; 1 Esd 9 27).

(29) A son of Amariah, a Judahite, the ancestor of certain persons dwelling in Jerus (Neh 11 4).

(30) A son of "the Shilonite," the ancestor of certain persons dwelling in Jerus (Neh 11 5).

BURTON SCOTT EASTON

**ZACHARIAH** (זְכַרְיָהּ, *z'kharyāh*, זְכַרְיָהּ, *z'kharyāhū*, "Jeh has remembered" [2 K 14 29; 15 8-12]; Ζαχαρίας, *Zacharias*; AV *Zachariah*): Son of Jeroboam II, and 14th king of Israel. He was the 4th of the line of Jehu, and reigned six months. Zechariah succeeded to a splendid inheritance, as he was king, not only of the ten tribes of Israel, but of the Syrian state of Damascus, which his father had subdued. In the unusual wealth and dignity of this position lay his peril. Also there were two dark shadows falling across his path, though both probably unseen by him. One was the promise to Jehu, as the reward of his destroying the worship of Baal in Israel, that his sons should sit on the throne of Israel to the 4th generation (2 K 10 30; 15 12). Zechariah was Jehu's great-great-

grandson. The other was the word of Amos to the priest of Bethel: "Then said the Lord . . . I will rise against the house of Jeroboam with the sword" (Am 7 8.9).

The only brief notice of Zechariah personal to himself is that he gave his support to the worship of the calves, since Jeroboam I established the religion of the state. He hardly had time, however, to identify himself with this or any institution before he was publicly assassinated by Shallum, the son of Jabesh (he "smote him before the people"). The prophet Hosea was then alive, and there is probably allusion to this crime when, addressing Ephraim, he says: "Where is thy king, that he may save thee in all thy cities? . . . I have given thee a king in mine anger, and have taken him away in my wrath" (Hos 13 10.11; cf 1 4).

There has long been difficulty with the chronology of this period. Archbishop Ussher assumed an interregnum of 11 years between the death of Jeroboam II and Zechariah's accession. This is accepted as probable by a recent writer, who sees "at least 10 years of incessant conflict between rival claimants to the throne on Jeroboam's death" (see art. "Zechariah" in *HDB*, IV). It seems more likely that there is error in certain of the synchronisms. The year of Zechariah's accession was probably 759 BC (some put it later), and the 6 months of his reign, with that given to Shallum, may be included in the 10 years of Menahem, who followed them (2 K 15 17). See CHRONOLOGY OF THE OT.

W. SHAW CALDECOTT

**ZACHARIAH, BOOK OF:**

1. The Prophet
2. His Times and Mission
3. Contents and Analysis
4. The Critical Question Involved
5. The Unity of the Book
6. Conclusion

**LITERATURE**

Few books of the OT are as difficult of interpretation as the Book of Zechariah; no other book is as Messianic. Jewish expositors like Abarbanel and Jarchi, and Christian expositors such as Jerome, are forced to concede that they have failed "to find their hands" in the exposition of it, and that in their investigations they passed from one labyrinth to another, and from one cloud into another, until they lost themselves in trying to discover the prophet's meaning. The scope of Zechariah's vision and the profundity of his thought are almost without a parallel. In the present writer's judgment, his book is the most Messianic, the most truly apocalyptic and eschatological, of all the writings of the OT.

Zechariah was the son of Berechiah, and the grandson of Iddo (Zec 1 1.7). The same Iddo seems to be mentioned among the

1. The Prophet  
priests who returned from exile under Zerubbabel and Joshua in the year 536 BC (Neh 12 4; Ezr 2 2). If so, Zechariah was a priest as well as a prophet, and presumably a young man when he began to preach. Tradition, on the contrary, declares that he was well advanced in years. He apparently survived Haggai, his contemporary (Ezr 5 1; 6 14). He was a poet as well as a prophet. Nothing is known of his end. The Tg says he died a martyr.

The earliest date in his book is the 2d year (520 BC) of the reign of Darius Hystaspis, and the latest, the 4th year of the same king's reign (1 1.7; 7 1). Though these are the

2. His Mission  
only dates given in his writings, it is possible of course that he may have continued active for several additional years. Otherwise, he preached barely two years. The conditions under which he labored were similar



to those in Haggai's times. Indeed, Haggai had begun to preach just two months before Zechariah was called. At that time there were upheavals and commotions in different parts of the Pers empire, esp. in the N.E. Jeremiah's prophecies regarding the domination of Babylon for 70 years had been fulfilled (Jer 15 11; 29 10). The returned captives were becoming disheartened and depressed because Jeh had not made it possible to restore Zion and rebuild the temple. The foundations of the latter had been already laid, but as yet there was no superstructure (Ezr 3 8-10; Zec 1 16). The altar of burnt offering was set up upon its old site, but as yet there were no priests worthy to officiate in the ritual of sacrifice (Ezr 3 2,3; Zec 3 3). The people had fallen into apathy, and needed to be aroused to their opportunity. Haggai had given them real initiative, for within 24 days after he began to preach the people began to work (Hag 1 1,15). It was left for Zechariah to bring the task of temple-building to completion. This Zechariah did successfully; this, indeed, was his primary mission and work.

The prophecies of Zechariah naturally fall into two parts, chs 1-8 and 9-14, both of which begin with the present and look forward to the distant future. (1) Chs 1-8, and Analysis consisting of three distinct messages delivered on three different occasions: (a) 1 1-6, an introduction, delivered in the 8th month of the 2d year of Darius Hystaspis (520 BC). These words, having been spoken three months before the prophecies which follow, are obviously a general introduction. They are decidedly spiritual and strike the keynote of the entire collection. In them the prophet issues one of the strongest and most intensely spiritual calls to repentance to be found in the OT. (b) 1 7-6 15, a series of eight night visions, followed by a coronation scene, all delivered on the 24th day of the 11th month of the same 2d year of Darius (520 BC), or exactly two months after the corner stone of the temple had been laid (Hag 2 18; Zec 1 7). These visions were intended to encourage the people to rebuild God's house. They are eight in number, and teach severally the following lessons:

(a) The vision of the horses (1 7-17), teaching God's special care for and interest in his people: "My house shall be built" (ver 16). (β) The four horns and four smiths (1 18-21), teaching that Israel's foes have finally been destroyed; in fact that they have destroyed themselves. There is no longer, therefore, any opposition to building God's house. (γ) The man with a measuring line (ch 2), teaching that God will re-people, protect and dwell in Jerus as soon as the sacred edifice has been built. The city itself will expand till it becomes a great metropolis without walls; Jeh will be a wall of fire round about it. (δ) Joshua, the high priest, clad in filthy garments, and bearing the sins both of himself and the people (ch 3); but cleansed, continued and made typical of the Messiah-Branch to come. (e) The candelabrum and the two olive trees (ch 4), teaching that the visible must give place to the spiritual, and that, through "the two sons of oil," Zerubbabel the layman, and Joshua the priest (ver 14), the light of God's church will continue to burn with ever-flaming brightness. For it is "not by might" but by Jeh's Spirit, i.e. by Divine life and animation, by Divine vigor and vivacity, by Divine disposition and courage, by Divine executive ability and technical skill, that God's house shall be built and supplied with spiritual life (ver 6). (f) The flying roll (5 1-4), teaching that when the temple is built and God's law is taught the land shall be purified from outward wickedness. (g) The Ephah (5 5-11); wickedness personified is borne

away back to the land of Shinar, teaching that when the temple is rebuilt wickedness shall be actually removed from the land. (θ) The four chariots (6 1-8), teaching that God's protecting providence will be over His sanctuary, and that His people, purified from sin, shall rest secure in Him. These eight visions are followed by a coronation scene, in which Joshua the high priest is crowned and made typical of the Messiah-Priest-King, whose name is Branch (6 9-15). (c) Chs 7, 8, Zechariah's answer to the Bethel deputation concerning fasting; delivered on the 4th day of the 9th month of the 4th year of Darius (518 BC). The Jews had been accustomed to fast on the anniversaries of the following four great outstanding events in the history of their capital: (α) when Nebuchadnezzar took Jerus, in the 4th month (Jer 52 6); (β) when the Temple was burned in the 5th month (Jer 52 12); (γ) when Gedaliah was murdered in the 7th month (Jer 41 2); and (δ) when the siege of Jerus was begun in the 10th month (2 K 25 1).

There are four sections to the prophet's answer divided by the slightly varying formula, "The word of Jeh came unto me" (7 4,8; 8 1,18), and teaching: (a) Fasting affects only yourselves; God requires obedience (7 4-7). (b) Look at the lesson from your fathers; they forsook justice and compassion and God punished them (7 8-14). (c) Jeh is now waiting to return to Jerus to save His people in truth and holiness. In the future, instead of a curse God will send blessing, instead of evil, good (8 1-17). (d) In fact, your fasts shall be changed into festivals, and many nations shall in that day seek Jeh of hosts in Jerus (8 18-23).

(2) Chs 9-14, consisting of two oracles, without dates; (a) chs 9-11, an oracle of promise to the new theocracy. This section contains promises of a land in which to dwell, a return from exile, victory over a hostile world-power, temporal blessings and national strength, closing with a parable of judgment brought on by Israel's rejection of Jeh as their shepherd; thus Judah and Ephraim restored, united and made victorious over their enemies, are promised a land and a king (ch 9); Israel shall be saved and strengthened (ch 10); Israel shall be punished for rejecting the shepherding care of Jeh (ch 11); (b) chs 12-14, an oracle describing the victories of the new theocracy, and the coming day of Jeh. This section is strongly eschatological, presenting three distinct apocalyptic pictures: thus, how Jerus shall be besieged by her enemies, but saved by Jeh (ch 12); how a remnant of Israel purified and refined shall be saved (ch 13); closing with a grand apocalyptic vision of judgment and redemption—the nations streaming up to Jerus to keep the joyous Feast of Tabernacles, and everything in that day becoming holy to Jeh.

There are two opposing schools of criticism in regard to the origin of chs 9-14; one holds what is known as the prexilic hypothesis, according to which chs 9-14 were written before the downfall of Jerus; more specifically, that chs 9-11 and 13 7-9 spring from the 8th cent. BC, having been composed perhaps by Zechariah, the son of Jeberechiah mentioned in Isa 8 2; whereas chs 12-14, excepting 13 7-9, were composed by some unknown contemporary of Jeremiah in the 7th cent. BC. On the other hand, there are also those who advocate a late post-Zecharian origin for chs 9-14, somewhere about the 3d cent. BC. The latter hypothesis is today the more popular. Over against these the traditional view, of course, is that Zechariah, near the close of the 6th cent., wrote the entire book ascribed to him. Only chs 9-14 are in dispute. No one doubts the genuineness of chs 1-8.

The following are the main arguments of those who advocate a pre-exilic origin for these oracles: (1) 11 8, "And I cut off the three shepherds in one month." These "three shepherds" are identified with certain kings who reigned but a short time each in the Northern Kingdom; for example, Zechariah, Shallum and Menahem (2 K 15 8-14). But the difficulty with this argument is that they were not cut off "in one month"; Menahem, on the contrary, reigned 10 years in Samaria (2 K 15 17). (2) 12 11-14, which speaks of "a great mourning in Jerus, as the mourning of Hadadrimmon in the valley of Megiddo," is claimed to fix the date of chs 12-14. Josiah fell in the valley of Megiddo (2 K 23 29; 2 Ch 35 22). But surely the mourning of Judah for Josiah might have been remembered for a century, from 609 BC till 518 BC. (3) 14 5, referring to the "earthquake" in the days of Uzziah, is another passage fastened upon to prove the pre-exilic origin of these prophecies. But the earthquake which is here alluded to took place at least a century and a half before the date assigned for the composition of ch 14. And surely if an earthquake can be alluded to by an author 150 years after it occurs, Zechariah, who lived less than a century later, might have alluded to it also. (4) A much stronger argument in favor of a pre-exilic origin of these prophecies is the names given to the theocracy, e.g. "Ephraim" and "Jerusalem" (9 10), "Judah" and "Ephraim" (9 13), "house of Judah" and "house of Joseph" (10 6), "Judah and Israel" (11 14), implying that the kingdoms of Israel and Judah are still standing. But subsequent to the captivity the Jews ever regarded themselves as representatives of the 12 tribes, as is obvious from their offering 12 sacrifices (Ezr 6 17; 8 35). Moreover, old names such as "Israel" and "Judah" long survived (cf Jer 31 27-31; Zec 8 13). (5) 14 10, which defines the area occupied by Judah as extending "from Geha to Rimmon," which corresponds, it is alleged, with the conditions which prevailed just prior to the captivity. But it satisfies equally well the conditions after the exile in Zechariah's own time. (6) Again, it is argued that the national sins, the prevailing sins, idolatry, teraphim and false prophecy (10 2; 13 2-6), are those of pre-exilic times. But the same sins persisted in the post-exilic congregation (Neh 6 7-14; Mal 2 11; 3 5), and there is no special emphasis laid upon them here. (7) Finally, it is argued that the enemies of Israel mentioned in chs 9-14 are those of pre-exilic times, Assyria and Egypt (10 10,11), Syria, Phoenicia and Philistia (9 1-7). But forms of expression are slow in changing; the name "Assyrians" occurs in Lam 5 6, and "Assyria" is employed instead of "Persia" in Ezr 6 22. Jeremiah prophesied against Damascus and Hamath long after their loss of independence (49 23-27). After the exile, the Philis resisted Israel's return (Neh 4 7,8). In short all these nations were Israel's hereditary foes, and, therefore, judgments pronounced against them were always in place. Furthermore, it may be said in general that there are reasons for thinking that, in both halves of the Book of Zec, the exile is represented as an event of the past, and that the restoration from exile both of Ephraim and Judah, though incomplete, has already begun. This is unquestionably true of chs 1-8 (1 12; 2 6-12; 6 10; 7 5; 8 7,8). The exile is treated as a fact. It is almost equally true of chs 9-14 (cf 9 8,11; 10 6,8-10). Moreover, it may with justice be claimed that the alleged authors of chs 9-14 dissociate themselves from any definitely named person or any specific event known to be pre-exilic. God alone is described as Ruler of His people. The only king mentioned is the Messiah-King (9 9,10; 14 9). The "house of David" mentioned in 12 7-12; 13 1, is never described as in possession of the throne. It is David's "house," and not any earthly ruler in it, of which the prophet speaks. Further, there are passages, indeed, in chs 9-14 which, if pre-exilic in origin, would have been obscure and even misleading to a people confronted by the catastrophes of 722 and 586 BC. No specific enemy is alluded to. No definite army is named as approaching. Instead of Assyria, Javan is painted as the opposing enemy of the theocracy (9 13), and even she is not yet raised up or even threatening. On the other hand, in chs 12-14, it is not the Chaldaeans under Nebuchadnezzar, but "all nations," who are described as coming up against Jerus (12 2,3; 14 2). Moreover, victory and not defeat is promised (9 8,14,16; 12 4,7,8). The pre-exilic prophets Amos, Hosea and Jeremiah held out no such hopes. These oracles, however, promise even temporal prosperity and abundance (9 17; 10 1,8,12; 12 8; 14 2,14); and they exhort the people to rejoice rather than to fear (9 9; 10 7); while in 14 16-19 all nations are represented as going up to Jerus to keep the Feast of Tabernacles, which was the most joyous feast of the Heb calendar. All this is quite the opposite of what the pre-exilic prophets (who are known to have been pre-exilic) actually prophesied. In Zec 9-14, there is sounded forth not one clear note of alarm or warning; judgment rather gives place to hope, warning to encouragement, threatening to joy and gladness, all of which is most inconsistent with the idea that these chapters are of pre-exilic origin. On the other hand, they are perfectly consistent with the conditions and promises of post-exilic times.

The other hypothesis remaining to be discussed is that known as the post-Zecharian. This may be said to represent the prevailing critical view at the present time. But it, like the pre-exilic hypothesis, is based upon a too literalistic and mechanical view of prophecy. Those, like Stade, Wellhausen, Kuenen, Marti, Kautzsch, Cornill, Cheyne, Driver, Kuiper, Echartd and Mitchell, who advocate this view, employ the same critical methods as those whose views we have just discussed, but arrive at diametrically opposite conclusions. Indeed, no two critics agree as to the historical circumstances which produced these oracles. Most are of the opinion, however, that these chapters were composed during the Gr period, i.e. after 333 BC. In examining the arguments urged by the representatives of this school special caution is needed in distinguishing between the grounds advanced in support of a post-exilic and those which argue a post-Zecharian date. The former we may for the most part accept, as Zechariah was himself a post-exilic prophet; the latter we must first examine. In favor of a very late or Grecian origin for chs 9-14, the chief and all-important passage, and the one upon which more emphasis is placed than upon all others together, is 9 13, "For I have bent Judah for me, I have filled the bow with Ephraim; and I will stir up thy sons, O Zion, against thy sons, O Greece, and will make thee as the sword of a mighty man." Kuiper in summing up throws the whole weight of his argument in favor of a Gr date on this verse. Wellhausen makes it decide the date of these prophecies; while Stade declares that the announcement of the "sons of Javan" is alone sufficient to prove that these prophecies are after 333 BC. Two things are esp. emphasized by critics in connection with this important passage: (1) that the sons of Javan are the world-power of the author's day, viz. the Gr-Maccabean world-power; and (2) that they are the enemies of Zion. But in opposition to these claims it should be observed (1) that the sons of Javan are but one of several world-powers within the range of the prophet's horizon (9 1-7, Syria, Phoenicia, Philistia; 12 2 f; 14 2 f, all nations; and 10 10,11, Assyria and Egypt); and (2) that the Greeks under Alexander were not the enemies of Zion, and did not fight against the Jews, but against the Persians. Assuming the genuineness of the passage (9 13), the following considerations point to the Pers period as its probable historical background: (a) The prophecy would be vague and meaningless if uttered after the invasion of Alexander. (b) The passage does not describe a victory for the sons of Javan, but rather a defeat. (c) It is introduced by an appeal to those still in exile to return, which would have been quite meaningless after Alexander's conquest. (d) In short, 9 13-17, as a whole, is not a picture of actual war, but rather an apocalyptic vision of the struggle of Israel with the world-power of the West, hence its indefiniteness and figurative language.

Furthermore, it must not be forgotten that in Zechariah's own day the Greeks were rapidly becoming a menacing world-power. In the first 3 years (521-519 BC) of Darius' reign, 12 different revolts took place, principally in the N. and E. But, in 518, Darius was compelled to move westward at the head of his royal armies; Darius' visit to Egypt in 517 BC was cut short by the disturbances of the Greeks (cf Wiedemann, *Gesch.*, 236). In the year 516 BC the Greeks of the Hellespont and Bosphorus, with the island of Samos, were made to submit to Pers rule. The next year (515 BC), Darius led an expedition against the Scythians across the Danube, the failure of which encouraged the Ionians subsequently to revolt. In 500 BC the great Ionian revolt actually took place. In 499 BC Sardis, the most important stronghold for Persia in Asia Minor, was burned by the Athenians. In 490 BC Marathon was fought and by Persia was conquered. In 480 BC Xerxes was defeated at Salamis. But it is unnecessary to sketch the rise of Javan further. Enough has been related to show that already in the reign of

**Darius Hystaspis**—In whose reign Zechariah is known to have lived and prophesied—the sons of Greece were a rising world-power, and a threatening world-power. This is all really that is required by the passage. The sons of Javan were but one of Israel's enemies in Zechariah's day; but they were of such importance that victory over them carried with it momentous Messianic interests. The language of ch 9 is vague, and, in our judgment, too vague and too indefinite to have been uttered after Marathon (490 BC), or even after the burning of Sardis (500 BC); for, in that case, the author would have been influenced more by Greece and less by the movements and commotions of the nations.

Other arguments advanced by the post-Zecharian school are: (1) 14 9, "And Jeh shall be King over all the earth: in that day shall Jeh be one, and his name one." To Stade this passage contains a polemic against the conditions in Gr times when all gods were conceived of as only different representations of one and the same god. But, on the contrary, the post-exilic congregation was as truly a theocracy in the days of Darius Hystaspis as in the period subsequent to Alexander's conquest. The Jewish colony of the Restoration was a religious sect, not a political organization. Zechariah often pictures the close relation of Jeh to His people (2 10-13; 8 3.23), and the author of chs 9-14 describes similar conditions. The "yearning for a fuller theocracy," which Cheyne (*Bampton Lectures*, 120) discovers in Zec 9-14, is thoroughly consistent with the yearning of a struggling congregation in a land of forsaken idols shortly after the return from exile. (2) 12 2b, interpreted to mean that "Judah also, forced by the enemy, shall be in the siege against Jerus," is a proof, it is alleged, that the children of the Diaspora had served as soldiers. The verse, accordingly, is said to be a description of the hostile relations which actually existed between Jerus and Judah in the beginning of the Maccabean struggle. The validity of these claims, however, is vitiated by a correct exegesis of the passage in hand. The text is apparently corrupt. In order to obtain a subject for "shall be," the preposition before Judah had better be stricken out, as in the Tg. The passage then tr<sup>d</sup> reads, "And Judah also shall be in the siege against Jerus." But this is ambiguous. It may mean that Judah shall fight against Jerus, or it may mean that Judah, too, shall be besieged. The latter is obviously the true meaning of the passage, as ver 7 indicates. For, as one nation might besiege Jerus (a city), so all nations, coming up are practically going to besiege Judah. The LXX favors this interpretation; likewise the Coptic VS; and Zec 14 14. Wellhausen frankly concedes that "no characteristic of the prophecy under discussion in reality agrees with the conditions of the Maccabean time. The Maccabees were not the Jews of the lowland, and they did not join themselves with the heathen out of hatred to the city of Jerus, in order finally to fall treacherously upon their companions in war. There is not the slightest hint in our passage of religious persecution; that alone decides, and hence the most important sign of Maccabean times is wanting." (3) 10 10.11, which mentions "Egypt" and "Assyria" (and which, strange to say, is also one of the strongest proofs in support of the præxilic hypothesis), is singularly enough interpreted to refer respectively to the Ptolemies of Egypt and the Seleucidae of Syria. But this is quite impossible, and esp. so in view of the prominence which is given to Egypt in 14 19, which points to Pers rather than Gr conditions; for then Egypt, in consequence of her perpetual efforts to throw off the Pers yoke, was naturally brought under the observation of the Jews in Pal, who repeatedly beheld the Pers armies passing on their way to the valley of the Nile.

(4) Still another argument advanced in favor of a late post-Zecharian date for these oracles is that from language and style: Aramaisms, *scriptio plena*, the pre-

ponderance of the shorter form of the personal pronoun "I," the Heb ending *ân*, the frequent use of the *nota accusativi*, esp. with suffixes, the omission of the article, the use of the infinitive absolute, and the clumsy diction and weary repetition of these prophecies are pointed to as evidence of their origin in Grecian times. But in opposition to these claims, it may be remarked in general that their force is greatly weakened by two considerations: (a) the fact that the author of chs 9-14 depends so largely on older prophecies for his thoughts, and consequently more or less for his language; and (b) the fact that these prophecies are so very brief. There is no mode of reasoning so treacherous as that from language and style. (For the technical discussion of this point, see the present writer's *The Prophecies of Zechariah*, 54-59.)

Among the further objections made to the genuineness of chs 9-14, and consequently to the unity of the book, the following are the chief:

**5. The Unity of the Book** (1) There are no "visions" in these oracles as in chs 1-6. But there are none either in chs 7, 8, and yet these latter are not denied to Zechariah.

As a matter of fact, however, visions do actually occur in chs 9-14, only of a historico-parabolic (11 4-17) and eschatological character (9 13-17; chs 12, 14). (2) There are "no dates," as in 1 1.7; 7 1. But dates are seldom attached to "oracles" (Isa 13 1; 15 1; Nah 1 1; Hab 1 1; Mal 1 1). There is but one instance in the entire OT (Isa 14 28m); whereas "visions" are frequently dated. (3) There is "no Satan." But Satan is never mentioned elsewhere in any prophetic book of the OT. (4) There is "no interpreting angel" in chs 9-14. But "oracles" need no interpreting angel. On the other hand, "the Angel of Jeh" is mentioned in both parts (3 1 ff; 12 8), a fact which is far more noteworthy. (5) Proper names are wanting in chs 9-14, e.g. Zerubbabel and Joshua. But neither do these names occur in chs 7, 8. (6) The sins alluded to are different, e.g. theft and false swearing in 5 3.4; while in 10 2 seeking teraphim and in 13 2 ff false prophecy are named. But these sins may have existed side by side. What is far more noteworthy, in both parts the prophet declares that all these evils shall be taken away and removed out of the land (3 9; 5 9-11; 13 1.2). (7) The Messianic pictures are different, e.g. in chs 1-8 the Messiah is spoken of as Branch-Priest (3 8.9; 6 12.13); whereas in chs 9-14, as King (9 9.10). But in 6 13 it is expressly stated that the Branch-Priest "shall sit and rule upon his throne." Of far greater moment is the picture of the nations coming to Zion to worship Jeh. This remarkable picture recurs in all the different sections of the book (6 12.13.15; 8 20-23; 12 6; 14 16-19).

On the other hand, the following are some of the arguments which favor the genuineness of these disputed chapters: (1) The fundamental ideas of both parts are the same. By this we mean that the deeper we go the nearer we approach unity. As Dr. G. A. Smith argues against Graetz, who divides Hos 1-3 from Hos 4-14, "in both parts there are the same religious principles and the same urgent and jealous temper"; the same is equally true of Zec 1-8 and Zec 9-14. Certain similarities are esp. noteworthy, e.g. (a) an unusually deep, spiritual tone pervades the entire book. The call to a true repentance, first sounded forth in the introduction (1 1-7), is developed more and more throughout the entire 14 chs; thus, in the sanctifying of Joshua (3 4), in the message to Zerubbabel, "not by might, nor by power, but by my Spirit" (4 6), in the conditions of future blessing (6 15), in the answer to the Bethel deputation (7 5-9; 8 16 ff); and in chs 9-14, in the consecration of the remnant of the Philis (9 7), in the blessings to Ephraim (10 12), in the baptism of grace upon Jerus (12 10), in the fountain for sin (13 1), in the worship of Jeh (13 9), in the living waters going forth from Jerus (14 8), and in the dedication of everything as holy

unto the Lord (14 20.21). The tone which tempers these prophecies is an extraordinarily deep and spiritual one throughout. And this argument cannot be set aside by rejecting wholesale certain passages as later interpolations, as is done by Mitchell (*ICC*, 242-44). (b) There is a similar attitude of hope and expectation in both parts. This is esp. important. For example, (α) the return of the whole nation is a prevailing idea of happiness in both parts (2 6.10; 8 7.8; 9 12; 10 6.7). (β) The expectation that Jerus shall be inhabited (1 16.17; 2 4; 3 8.8; 12 6; 14 10.11), (γ) and that the temple shall be built and become the center of the nation's religious life (1 16.17; 3 7; 6 15; 7 2.3; 9 8; 14 20.21). (δ) Messianic hope is peculiarly strong in both (3 8.9; 6 12.13; 9 9.10; 11 12.13; 12 10; 13 1.7-9). (ε) Peace and prosperity are expected (1 17; 3 10; 6 13; 8 12.19; 9 10.12-17; 10 1.7.8.10.12; 12 8; 14 11.16-19). (ζ) The idea of God's providence as extending to the whole earth (1 14-17; 2 9.12; 4 10; 6 5; 9 1.8.14; 10 3.5.9.12; 12 2-4.8; 13 7; 14 3.9). Again, (c) the prophet's attitude toward Judah is the same in both parts. It is an attitude of supreme regard for Judah's interests, making them second only to the capital (2 2.4.16; 8 19; 1 12; 8 13.15; 12 2; 14 14; 10 3; 12 4.6.7; 14 21; 9 9.13; 10 6; 11 14; 14 5). The prophet's attitude toward the nations, the enemies of the theocracy, is the same in both parts. The whole assembled world are the enemies of Israel. But though they have scattered Judah, Israel and Jerus (1 11), and are still coming up to besiege Jerus (12 2; 14 2), yet they shall be joined to the Lord in that day (2 11) and worship Jeh like the Jews (8 20-23; 14 16-19). These are all striking instances of similarity in the fundamental ideas of the two parts of the book.

(2) There are peculiarities of thought common to both parts: e.g. (a) the habit of dwelling on the same thought (2 1.4.5.11; 6 12.13; 8 4.5; 8 21.22; 11 8; 13 3; 14 5.16.18.19); (b) the habit of expanding one fundamental thought into a series of clauses (6 13; 9 5.7; 1 17; 3 8.9; 12 4); (c) the habit of referring to a thought already introduced: e.g. to the "Branch" (3 8; 6 12); "eyes" (3 9; 4 10); measuring "line" (1 16; 2 5.6); choosing Jerus (1 17; 2 12; 3 2); removing iniquity (3 9; 5 3 ff; 13 2); measurements (5 2; 14 10); colors of horses (1 8; 6 2.6); the idea of Israel as a "flock" (9 16; 10 2; 11 4 f; 13 7); idols (10 2; 13 2); shepherds (11 3 ff; 13 7); and of "all nations" (11 10; 12 3 ff; 14 2 ff); Mitchell in attempting to answer this argument has failed utterly to grasp the point (*ICC*, 243); (d) the use made of the cardinal number "two"; thus, two olive trees (4 3); two women (6 9); two mountains (6 1); two staves (11 7); two parts (14 2.4); with which compare 6 13; 9 12; 14 8; (e) the resort in each part of the book to symbolic actions as a mode of instruction; e.g. the coronation scene in 6 9-15, and the breaking of the two staves in 11 4-14.

(3) Certain peculiarities of diction and style favor unity of authorship; e.g. the phrase "no man passed through nor returned" (7 14; 9 8) never occurs elsewhere in the OT. The author's preference for and frequent use of vocatives (2 7.10; 3 2.8; 4 7; 9 9.13; 11 1.2; 13 7); and esp. the frequent alternation of the *scriptio plena* and the *scriptio defectiva* orthography in the Heb (cf 1 2.5 with 1 4.6 and 8 14; 2 11 with 5 7; 1 11 with 7 7; 9 5 with 10 5.11; and 10 4 with 9 9).

Accordingly, we conclude, (1) that chs 9-14 are of post-exilic origin; (2) that they are not, however, late post-exilic; (3) that they had their origin in the period just before the completion of the temple, 516 BC, and (4) that they were probably composed by

Zechariah himself. This conclusion is based upon the text taken as a whole, without an arbitrary dissection of the prophecies in the interests of a false theory. Mitchell (*ICC*, 258-59), after eliminating numerous individual passages, arrives at the conclusion that chs 9-14 were written by four different writers; (1) 9 1-10, soon after 333 BC; (2) 9 11-11 3, about 247-222 BC; (3) 11 4-17 and 13 7-9, between 217 and 204 BC; and (4) 12 1-13 6 and ch 14, about the same time. Tradition points to a saner and securer conclusion, that these oracles were written by Zechariah himself; which in turn is corroborated by internal evidence, as has been shown above. One wonders why these oracles, written so late in Israel's history, should have been appended by the collectors of the Canon to the genuine prophecies of Zechariah, if, as is alleged, that prophet had nothing whatever to do with them!

6. Conclusion

LITERATURE.—(1) *Those who defend the unity of the book*: C. H. H. Wright, *Zechariah and His Prophecies* (Bampton Lectures), London, 1879; G. L. Robinson, *The Prophecies of Zec.*, with Special Reference to the Origin and Date of Chs 9-14, Leipzig Dissertation, reprinted from *AJSL*, XII, 1896; W. H. Lowe, *Heb Student's Comm. on Zec.*, Heb and LXX, London, 1882; C. J. Bredenkamp, *Der Prophet Sach.*, Erklärt, 1879; Marcus Dods, *The Post-Exilian Prophecies: Hag., Zech., Mal.* ("Handbook for Bih. Classes"), Edinburgh, 1879; E. B. Pusey, *Minor Prophecies*, 1877; W. Drake, "Comm. on Zec" (*Speaker's Comm.*), 1876; T. W. Chambers, "The Book of Zec" (*Langze's Bible Works*), 1874; A. Van Hoonacker, in *Revue Biblique*, 1902, 161 ff; idem, *Les douze petits prophètes*, 1908; Wm. Moeller, art. "Zechariah" in *The Illustrated Bible Dict.*, edited by W. C. Piercy, 1908.

(2) *Those who advocate a preëxilic origin for chs 9-14*: Hitzig-Steiner, *Die zwölf kleinen Propheten*, 1881; Samuel Davidson, *An Intro to the OT*, 1862-63; W. Pressel, *Commentar zu den Schriften der Propheten Haggai, Sacharia und Maleachi*, 1870; C. A. Bruston, *Histoire critique de la littérature prophétique des Hébreux*, 1881; Samuel Sharpe, *History of the Heb Nation, Literature and Chronology*, 1882; C. von Orelli, *Das Buch Ezechiel u. die zwölf kleinen Propheten*, 1888; Ferd. Montet, *Étude critique sur la date assignable aux six derniers chapitres de Zac.*, 1882; H. L. Strack, *Einteilung in das AT*, 1895; F. W. Farrar, *Minor Prophets*, in "Men of the Bible" series.

(3) *Those who advocate a post-Zecharian origin for chs 9-14*: B. Stade, "Deuterozacharia, eine krit. Studie," in *ZATW*, 1881-82; T. K. Cheyne, "The Date of Zec 9-14," in *JQR*, I, 1889; C. H. Cornill, *Einteilung in das AT*, 1891; S. R. Driver, *Intro to the Literature of the OT*, 1910; J. Wellhausen, *Die kleinen Propheten übersetzt*, 1893; N. I. Rubinkam, *The Second Part of the Book of Zec.*, 1892; Karl Marti, *Der Prophet Sacharia*, 1892; A. F. Kirkpatrick, *Doctrine of the Prophets*, 1892; R. Eckardt, "Der Sprachgebrauch von Zach 9-14," *ZATW*, 1893, 76-109; A. K. Kuiper, *Zacharia 9-14; eine exegetisch-critische Studie*, 1894; J. W. Rothstein, *Die Nachtgesichte des Sacharia*, 1910; G. A. Smith in *Expositor's Bible*, 1896-97; S. R. Driver in *The New Century Bible*; H. G. Mitchell, *ICC*, 1912.

GEORGE L. ROBINSON

ZECHEER, zē'kēr (זְכַרְיָהּ), zākher, pausal form for זְכָרִי, zekher, "memorial"; AV Zacher; In 1 Ch 8 31 = "Zechariah" of 1 Ch 9 37. See ZECHARIAH, (5).

ZECHRIAS, zek-ri'as (Β, Ζεχρίας, Zechrias, A and Fritzsche, Εἰςρίας, Ezerias; AV Ezerias); An ancestor of Ezra (1 Esd 8 1) = "Azariah" of Ezr 7 1.

ZEDAD, zē'dad (זְדָדָה, zēdhādhāh, only found with Hē locale; Sam זְדָדָה, zēradhāh; LXX Σαπαδάκ, Saradāk, Saḏadāk, Sadadāk, Saḏḏāk, Saḏḏāk): A town or district named in Nu 34 8; Ezk 47 15 as on the ideal northern boundary of Israel. The uncertainty of the reading has led to two different identifications being proposed. The form "Zerad" was accepted by von Kasteren, and his identification was *Khribet Serada* in the *Merj 'Ayun*, W. of the Hasbany branch of the Jordan and N. of 'Abil. This identification, however, would compel us to draw the ideal boundary along the *Qasmiyeh* valley and thence eastward to Hermon, and that

is much too far S. If with Dillmann, Wetzstein, Muehlau and others we read "Zedad," then it is clearly identical with *Sadad*, a village on the road between *Ribleh* and *Karjetain*. It has been objected that *Sadad* is too far to the E.; but here, as in the tribal boundaries also, the references are rather to the district or lands possessed than to their central town or village. W. M. CHRISTIE

**ZEDECHIAS**, zed-ê-kî'as: 1 Esd 1 46 AV=RV "Sedekias."

**ZEDEKIAH**, zed-ê-kî'a (זִדְקִיָּהוּ, *zidhkiyāhū*, זִדְקִיָּהוּ, *zidhkiyāh*, "Jeh my righteousness"; **Σεδεκιάς**, *Sedekias*, **Σεδεκίας**, *Sedekias*):

(1) The son of Chenaanah (1 K 22 11,24; 2 Ch 18 10,23). Zedekiah was apparently the leader and spokesman of the 400 prophets attached to the court in Samaria whom Ahab summoned in response to Jehoshaphat's request that a prophet of Jeh should be consulted concerning the projected campaign against Ramoth-gilead. In order the better to impress his audience Zedekiah produced iron horns, and said to Ahab, "With these shalt thou push the Syrians, until they be consumed." He also endeavored to weaken the influence of Micaiah ben Imlah upon the kings by asking ironically, "Which way went the Spirit of Jeh from me to speak unto thee?"

In Jos (*Ant.* VIII, xv, 4) there is an interesting rearrangement and embellishment of the Bih. narrative. There Zedekiah is represented as arguing that since Micaiah contradicts Elijah's prediction as to the place of Ahab's death, he must be regarded as a false prophet. Then, smiting his opponent, he prayed that if he were in the wrong his right hand might forthwith be withered. Ahab, seeing that no harm befell the hand that had smitten Micaiah, was convinced; whereupon Zedekiah completed his triumph by the incident of the horns mentioned above.

(2) The son of Maaseiah (Jer 29 21-23). A false prophet who, in association with another, Ahab by name, prophesied among the exiles in Babylon, and foretold an early return from captivity. Jeremiah sternly denounced them, not only for their false and reckless predictions, but also for their foul and adulterous lives, and declared that their fate at the hands of Nebuchadnezzar should become proverbial in Israel.

(3) The son of Hananiah (Jer 36 12). One of the princes of Judah before whom Jeremiah's roll was read in the 5th year of Jehoiakim.

(4) One of the officials who sealed the renewed covenant (Neh 10 1, AV "Zid-kijah"). The fact that his name is coupled with Nehemiah's suggests that he was a person of importance. But nothing further is known of him.

(5) The last king of Judah (see following art.).

JOHN A. LEES

**ZEDEKIAH** (זִדְקִיָּהוּ, *zidhkiyāhū*, "Jeh my righteousness"; name changed from Mattaniah (מַתַּנְיָהוּ, *mattanyāh*, "gift of Jeh"; **Σεδεκίας**, *Sedekias*):

#### I. SOURCES FOR HIS REIGN AND TIME

1. Annalistic
2. Prophetic

#### II. THE ADMINISTRATION OF THE LAST KING OF JUDAH

1. The Situation
2. The Parvenu Temper
3. Inconsistencies
4. Character of the King
5. His Fate
6. Doom of the Nation

The last king of Judah, uncle and successor of Jehoiachin; reigned 11 years, from 597 to 586, and was carried captive to Babylon.

**I. Sources for His Reign and Time.**—Neither of the accounts in 2 K 24 18-25 7 and 2 Ch 36 11-21 refers, as is the usual custom, to state annals;

these ran out with the reign of Jehoiakim. The history in 2 K is purely scribal and annalistic in tone; 2 Ch, esp. as it goes on to the

**1. Annalistic**  
Both have a common prophetic origin; and indeed the last chapter of Jer (52), which is put as an appendix to the book of his prophecy, tells the story of the reign and subsequent events, much as does 2 K, but in somewhat fuller detail.

Two prophets are watching with keen eyes the progress of this reign, both with the poignant sense that the end of the Judaean state is imminent: Jeremiah

**2. Prophetic** in Jerus and Ezekiel, one of the captives in the deportation with Jehoiachin, in Babylon. Dates are supplied with the prophecies of both: Jeremiah's numbered from the beginning of the reign and not consecutive; Ezekiel's numbered from the beginning of the first captivity, and so coinciding with Jeremiah's. From these dated prophecies the principal ideas are to be formed of the real inwardness of the time and the character of the administration. The prophetic passages identifiable with this reign, counted by its years, are: Jer 24, after the deportation of Jehoiachin (Jeconiah)—the inferior classes left with Zedekiah (cf Ezk 11 15; 17 12-14); Jer 27-29, beginning of reign—false hopes of return of captives and futile diplomacies with neighboring nations; Jer 51 59, 4th year—Z's visit to Babylon; Ezk 4-7, 5th year—symbolic prophecies of the coming end of Judah; Ezk 8-12, 6th year—quasi-clairvoyant view of the idolatrous corruptions in Jerus; Ezk 17 11-21, same year—Z's treacherous intrigues with Egypt; Ezk 21 18-23, 7th year—Nebuchadnezzar casting a divination to determine his invasion of Judah; Jer 21, undated but soon after—deputation from the king to the prophet inquiring Jeh's purpose; Jer 34 1-7, undated—the prophet's word to the king while Nebuchadnezzar's invasion is still among the cities of the land; Ezk 24 1,2, 9th year—telepathic awareness of the beginning of the siege, synchronous with Jer 39 1-10; 2 K 25 1-7; Jer 37, 38, undated, but soon after—prophecies connected with the temporary raising of the siege and the false faith of the ruling classes; Jer 32, 10th year—Jeremiah's redemption of his Anathoth property in the midst of siege, and the good presage of the act; Jer 39, 11th year—annalistic account of the breaching of the city wall and the flight and eventual fate of the king. A year and a half later Ezekiel (33 21,22) hears the news from a fugitive.

**II. The Administration of the Last King of Judah.**—When Nebuchadnezzar took away Jehoiachin, and with him all the men of weight

**1. The Situation**  
his object was plain: to leave a people so broken in resources and spirit that they would not be moved to rebellion (see Ezk 17 14). But this measure of his effected a segmentation of the nation which the prophets immediately recognized as virtually separating out their spiritual "remnant" to go to Babylon, while the worldly and inferior grades remained in Jerus. These are sharply distinguished from each other by Jeremiah in his parable of the Figs (ch 24), published soon after the first deportation. The people that were left were probably of the same sort that Zephaniah described a few years before, those who had "settled on their lees" (1 12), a godless and inert element in religion and state. Their religious disposition is portrayed by Ezekiel in Z.'s 6th year, in his clairvoyant vision of the uncouth temple rites, as it were a cesspool of idolatry, maintained under the pretext that Jeh had forsaken the land (see Ezk 8). Clearly these were not of the prophetic stamp. It was over such an inferior grade of people that Z. was appointed to a thankless and tragic reign.

For a people so raw and inexperienced in administration the prophets recognized one clear duty: to keep the oath which they had given to Nebuchadnezzar (see Ezk 17 14-16).

**2. The Parvenu Temper**  
But they acted like men intoxicated with new power; their accession to property and unwanted position turned their heads. Soon after the beginning of the reign we find Jeremiah giving emphatic warning both to his nation and the ambassadors of neighboring nations against a rebellious coalition (Jer 27 mistakenly dated in the 4th year of Jehoiakim; cf vs 3.12); he has also an encounter with prophets who, in contradiction of his consistent

message, predict the speedy restoration of Jehoiachin and the temple vessels. The king's visit to Babylon (Jer 51 59) was probably made to clear himself of complicity in treasonable plots. Their evil genius, Egypt, however, is busy with the too headstrong upstart rulers; and about the middle of the reign Z. breaks his covenant with his over-lord and, relying on Egypt, embarks on rebellion. The prophetic view of this movement is, that it is a moral outrage; it is breaking a sworn word (Ezk 17 15-19), and thus falsifying the truth of Jeh.

This act of rebellion against the king of Babylon was not the only despite done to "Jeh's oath." Its

### 3. Incon- stencies

mediate effect, of course, was to precipitate the invasion of the Chaldean forces, apparently from Riblah on the Orontes, where for several years Nebuchadnezzar had his headquarters. Ezk has a striking description of his approach, halting to determine by arrow divination whether to proceed against Judah or Ammon (21 18-23). Before laying siege to Jerus, however, he seems to have spent some time reducing outlying fortresses (cf Jer 34 1-7); and during the suspense of this time the king sent a deputation to Jeremiah to inquire whether Jeh would not do "according to all his wondrous works," evidently hoping for some such miraculous deliverance as had taken place in the time of Senacherib (Jer 21 1ff). The prophet gives his uniform answer, that the city must fall; advising the house of David also to "execute justice and righteousness." Setting about this counsel as if they would bribe Jeh's favor, the king then entered into an agreement with his people to free all their Hebrew bond-slaves (Jer 34 8-10), and sent back a deputation to the prophet entreating his intercession (Jer 37 3), as if, having bribed Jeh, they might work some kind of a charm on the Divine will. Nebuchadnezzar had meanwhile invested the city; but just then the Egypt army approached to aid Judah, and the Bab king raised the siege long enough to drive the Egyptians back to their own land; at which, judging that Jeh had interfered as of old, the people caused their slaves to return to their bondage (34 11). This treachery called forth a trenchant prophecy from Jeremiah, predicting not only the speedy return of the Chaldaean army (Jer 37 6-10), but the captivity of the king and the destruction of the city (Jer 34 17-22). It was during this temporary cessation of the siege that Jeremiah, attempting to go to Anathoth to redeem his family property, was seized on the pretext of deserting to the enemy, and put in prison (37 11-15).

During the siege, which was soon resumed, Z.'s character, on its good and bad sides, was revealed

through his frequent contact with the  
4. Character prophet Jeremiah. The latter was of the King a prisoner most of the time; and the indignities which he suffered, and which the king heedlessly allowed, show how the prophet's word and office had fallen in respect (cf the treatment he received, Jer 26 16-19 with 37 15; 38 6). The king, however, was not arrogant and heartless like his brother Jehoiakim; he was weak and without consistent principles; besides, he was rather helpless and timid in the hands of his headstrong officials (cf 38 5.24-26). His regard for the word of prophecy was rather superstitious than religious: while the prophet's message and counsel were uniformly consistent, he could not bring himself to follow the will of Jeh, and seemed to think that Jeh could somehow be persuaded to change his plans (see Jer 37 17; 38 14-16). His position was an exceedingly difficult one; but even so, he had not the firmness, the wisdom, the consistency for it.

In his siege of the city Nebuchadnezzar depended mainly on starving it into surrender; and we cannot withhold a measure of admiration for a body of defenders who, in spite of the steadily decreasing

food supply and the ravages of pestilence, held the city for a year and a half. During this time

Jeremiah's counsel was well known: the  
5. His Fate counsel of surrender, and the promise that so they could save their lives (Jer 21 9; 38 2). It was for this, indeed, that he was imprisoned, on the plea that he "weakened the hands" of the defenders; and it was due to the mercy of a foreign slave that he did not suffer death (38 7-9). At length in the 11th year of Z.'s reign, just as the supply of food in the city was exhausted, the Chaldaean army effected a breach in the wall, and the king of Babylon with his high officials came in and sat in the middle gate. Z. and his men of war, seeing this, fled by night, taking the ill-advised route by the road to Jericho; were pursued and captured in the plains of the Jordan; and Z. was brought before the king of Babylon at Riblah. After putting to death Z.'s sons and the nobles of Judah before his eyes, the king of Babylon then put out the eyes of Z. and carried him captive to Babylon, where, it is uncertain how long after, he died. Jeremiah had prophesied that he would die in peace and have a state mourning (Jer 34 4.5); Ezekiel's prophecy of his doom is enigmatic: "I will bring him to Babylon to the land of the Chaldeans; yet shall he not see it, though he shall die there" (Ezk 12 13).

The cruelly devised humiliation of the king was only an episode in the tragic doom of the city and nation. Nebuchadnezzar was not

6. Doom of the Nation minded to leave so stubborn and treacherous a fortress on his path of conquest toward Egypt. A month after the event at Riblah his deputy, Nebuzaradan, entered upon the reduction of the city: burning the temple and all the principal houses, breaking down the walls, carrying away the temple treasures still unlooted, including the bronze work which was broken into scrap metal, and deporting the people who were left after the desperate resistance and those who had voluntarily surrendered. The religious and state officials were taken to Riblah and put to death. "So," the historian concludes, "Judah was carried away captive out of his land" (Jer 52 27). This was in 586 BC. This, however, was only the political date of the Bab exile, the retributive limit for those leavings of Israel who for 11 years had played an insincere game of administration and failed. The prophetic date, from which Ezekiel reckons the years of exile, and from which the prophetic eye is kept on the fortunes and character of the people who are to be redeemed, was 597, when Jehoiachin's long imprisonment began and when the flower of Israel, transplanted to a foreign home, began its term of submission to the word and will of Jeh. It was this saving element in Israel who still had a recognized king and a promised future. By both Jeremiah and Ezekiel, Z. was regarded not as Jeh's anointed but as the one whom Nebuchadnezzar "had made king" (Jer 37 1; Ezk 17 16), "the king that sitteth upon the throne of David" (Jer 29 16). The real last king of Judah was Jehoiachin; Ezekiel's title for Z. is "prince" (Ezk 12 10).

JOHN FRANKLIN GENUNG

ZEEB, zē'eb, zēb. See OREB AND ZEEB.

ZELA, ZELAH, zē'la (זֵלָה, zēlā' [2 S 21 14]): A city in the territory of Benjamin (Josh 18 28; LXX here omits). Here was the burying-place of the family of Saul, whither the bones of the king and of Jonathan were brought for burial (2 S 21 14; LXX here reads *en tē pleurá*, translating zēlā', "side"). The place is not identified. It may be the Zilu of the Am Tab.

**ZELEK**, zē'lek (זֶלֶק, *zelek*, meaning unknown): An Ammonite, one of David's mighty men (2 S 23 37; 1 Ch 11 39).

**ZELOPHEHAD**, zē-lō'fē-had (זֶלֹפְהָד, *zēlophēhadh*, meaning unknown): Head of a Manassite family who died without male issue (Nu 26 33; 27 1.7; 36 2.6.10.11; Josh 17 3; 1 Ch 7 15). His daughters came to Moses and Eleazar and successfully pleaded for a possession for themselves (Nu 27 1 ff). This became the occasion for a law providing that in the case of a man dying without sons, the inheritance was to pass to his daughters if he had any. A further request is made (Nu 36 2 ff) by the heads of the Gileadite houses that the women who were given this right of inheritance should be compelled to marry members of their own tribe, so that the tribe may not lose them and their property. This is granted and becomes law among the Hebrews.

Gray says (ICC on Nu 26 33) that the "daughters" of Zelophehad are towns or clans.

DAVID FRANCIS ROBERTS

**ZELOTES**, zē-lō'tēz (Ζηλωτής, *Zēlōtēs*). See SIMON THE ZEALOT; ZEALOT, ZEALOTS.

**ZELZAH**, zel'za (צֶלְצָח, *zelzah*; ἀλλομένουσ μεγάλα, *hallowménous megála*): A place where Samuel told Saul he would meet two men with news that the asses were found. Its position is defined as "by Rachel's sepulchre, in the border of Benjamin" (1 S 10 2). It has been thought that the place of meeting was sufficiently indicated without the word *b'zelzah*, which is tr<sup>d</sup> "at Zelzah," and that this cannot therefore be a place-name. The LXX "leaping mightily" or "in great haste" (Ewald) points to a different text. Whether the Gr can be so tr<sup>d</sup> is also a question, as *megala* does not elsewhere occur as an advb. Some corruption of the text is probable. The border of Benjamin may be roughly determined, but the tomb of Rachel is now unknown. No name like Zelzah has been recovered in the district. Smith ("Samuel," ICC, ad loc.) suggests that we should read "Zela" for "Zelzah" (עֶלְאָ, *elā'*, for צֶלְצָח, *zelzah*). W. EWING

**ZEMARAIM**, zem-a-rā'im (צֶמְרַיִם, *zēmārayim*; Β, Σαρὰ, *Sarà*, A, Σεμρίμ, *Semrīm*): A city in the territory of Benjamin. It is named between Betharabah and Bethel (Josh 18 22), and is probably to be sought E. of the latter city. It is usual to identify it with *es-Samra*, a ruin about 4 miles N. of Jericho. Mt. Zemaraim probably derived its name from the city, and must be sought in the neighborhood. On this height, which is said to be in Mt. Ephraim, Abijah, king of Judah, stood when making his appeal to the men of Israel under Jeroboam (2 Ch 13 4). If the identification with *es-Samra* is correct, this hill must be in the uplands to the W., *es-Samra* being on the floor of the valley. Dillmann (*Josh*, ad loc.) thinks Zemaraim cannot be so far E. of Bethel, but may be found somewhere to the S. of that town. W. EWING

**ZEMARITE**, zem'a-rīt (צֶמְרַיִם, *ha-zēmāri*; ὁ Σαμαρείτης, *ho Samaraitos*): A Can. people named in Gen 10 18; 1 Ch 1 16. The occurrence of the name between Arvadite and Hamathite gives a hint as to locality. A place called Sumur is mentioned in the Am Tab along with Arvad. The name probably survives in that of *Sumra*, a village on the seacoast between Tripolis and *Ruwād*, about 1½ miles N. of *Nahr el-Kebīr*. We may with some certainty identify this modern village with the site of the town from which the inhabitants were named "Zemarites."

**ZEMIRAH**, zē-mī'ra (זִמְרָה, *zēmīrah*, meaning uncertain; LXX B, Ἀμαρίας, *Amariās*, A, Ζαμαρίας, *Zamariās*; AV *Zemira*): A descendant of Benjamin (1 Ch 7 8), but more probably of Zebulun (Curtis, *Chron.*, 145 ff).

**ZENAN**, zē'nan. See ZAANAN.

**ZENAS**, zē'nas (Ζηνός, *Zēnós* [Tit 3 13]; the name in full would probably be Zenodorus, lit. meaning "the gift of Zeus"): Paul calls  
1. A Jewish Zenas "the lawyer." The meaning of Lawyer this is, that, previous to his becoming a Christian, he had been a Jewish lawyer. The lawyers were that class of Jewish teachers who were specially learned in the Mosaic Law, and who interpreted that Law, and taught it to the people.

They are met with again and again in the Gospels, where they frequently came into contact with Christ, usually in a manner hostile to Him. For example, "A certain lawyer stood up and made trial of him, saying, Teacher, what shall I do to inherit eternal life?" (Lk 10 25). Our Lord replied to him on his own ground, asking, "What is written in the law? how readest thou?" Regarding this class of teachers as a whole, it is recorded that "the Pharisees and lawyers rejected for themselves the counsel of God" (Lk 7 30). The term *nomikós*, "lawyer," applied to Zenas, is in the Gospels varied by *nomodidaskalos*, "a teacher of the law," and by *grammateús*, "a scribe": all three terms describe the same persons. Before his conversion to Christ, Zenas had been a lawyer, one of the recognized expounders of the Law of Moses.

A different view of Zenas' occupation is taken by Zahn (*Intro to the NT*, II, 54), who says that in itself *nomikos* could denote a rabbi, quoting Ambrosiaster, "Because Zenas had been of this profession in the synagogue, Paul calls him by this name." But Zahn gives his own opinion that "since the Jewish scribe who became a Christian, by that very act separated himself from the rabbinic body, and since the retention of rabbinic methods and ways of thinking was anything but a recommendation in Paul's eyes (1 Tim 1 7), Zenas is here characterized, not as *legis* (*Mosaicae*), *doctor*, but as *juris peritus*. The word denotes not an office, but usually the practical lawyer, through whose assistance e.g. a will is made, or a lawsuit carried on. Plutarch applies this name to the renowned jurist Mucius Scaevola."

The ordinary meaning seems preferable, which sees in Zenas one who previous to his conversion had been a Jewish rabbi.

It is not certain where Paul was when he wrote the Ep. to Titus. But he directs Titus to come to him to Nicopolis, where he had resolved

2. Paul's Wishes regarding Zenas  
to spend the ensuing winter. And he adds the injunction that he desires him to "bring Zenas the lawyer and Apollos"—Paul's old friend from Alex-

andria—with him "on their journey diligently, that nothing be wanting unto them" (AV). This may mean that Paul wished to have Zenas and Apollos with him at Nicopolis; but, on the other hand, it may not have this meaning. For the AV in translating "bring" is in error. The word signifies, as given in RV, "set forward" on their journey, that is, furnish them with all that they need for the journey. But even supposing Paul is not instructing Titus to bring Zenas and Apollos to Nicopolis—though this is perhaps what he means—yet it is most interesting to find these two friends of the apostle mentioned in this particular way, and esp. at a time so near to the close of his life. Paul was unselfish as ever, solicitous that Zenas and Apollos be comfortably provided for on their intended journey. He is full of affectionate regard for them, interested in their welfare at every step; while he himself is far distant in another country, he remembers them with tender and sympathetic friendship. Doubtless the two friends reciprocated his affection.

Nothing more is known of Zenas than is contained in this passage. JOHN RUTHERFURD

**ZEND-AVESTA**, zend-a-ves'ta. See PERSIAN RELIGION; ZOROASTRIANISM.

**ZEPHANIAH**, zef-a-ni'a (זְפַנְיָהּ, *ḥ'phanyāh*, זְפַנְיָהּ, *ḥ'phanyāhū*, "Jeh hath treasured"):

(1) The prophet. See ZEPHANIAH, BOOK OF.

(2) A Levite or priest (1 Ch 6 36 [Heb 6 21]), called in some genealogies "Uriel" (1 Ch 6 24; 15 5.11).

(3) Judaeen father or fathers of various contemporaries of Zechariah, the prophet (Zec 6 10.14).

(4) A priest, the second in rank in the days of Jeremiah. He was a leader of the "patriotic" party which opposed Jeremiah. Nevertheless, he was sent to the prophet as a messenger of King Zedekiah when Nebuchadnezzar was about to attack the city (Jer 21 1) and at other crises (Jer 37 3; cf 29 25.29; 2 K 25 18). That he continued to adhere to the policy of resistance against Bab authority is indicated by the fact that he was among the leaders of Israel taken by Nebuzaradan before the king of Babylon, and killed at Riblah (2 K 25 18 || Jer 52 24).  
NATHAN ISAACS

**ZEPHANIAH, APOCALYPSE OF:** A (probably) Jewish apocryphal work of this name is mentioned in the *Stichometry* of Nicephorus and another list practically identical with this; a quotation from it is also preserved by Clement of Alexandria (*Strom.*, v. 11. 77). Dr. Charles thinks this indicates a Christian revision (*Enc Brit*, II, art. "Apocalypse"); others suppose it to point to a Christian, rather than a Jewish, origin. See Schürer, *HJP*, div II, vol III, pp. 126-27, 132; *GJV*<sup>4</sup>, III, 367-69.

**ZEPHANIAH, BOOK OF:**

**I. THE AUTHOR**

- 1. Name
- 2. Ancestry
- 3. Life

**II. TIME**

- 1. Date
- 2. Political Situation
- 3. Moral and Religious Conditions

**III. BOOK**

- 1. Contents
- 2. Integrity

**IV. TEACHING**

- 1. The Day of Jehovah
- 2. Universalism
- 3. Messianic Prophecy

**LITERATURE**

**I. The Author.**—The name "Zephaniah" (זְפַנְיָהּ, *ḥ'phanyāh*; *Σοφονίας*, *Sophonias*), which is borne by three other men mentioned in

**1. Name** OT, means "Jeh hides," or "Jeh has hidden" or "treasured." "It suggests," says G. A. Smith, "the prophet's birth in the killing time of Manasseh" (2 K 21 16).

The ancestry of the prophet is carried back four generations (1 1), which is unusual in the OT (cf Isa 1 1; Hos 1 1); hence it is thought,

**2. Ancestry** not without reason (Eiselen, *Minor Prophets*, 505), that the last-mentioned ancestor, Hezekiah, must have been a prominent man—indeed, no other than King Hezekiah of Judah, the contemporary of Isaiah and Micah. If Zephaniah was of royal blood, his condemnation of the royal princes (1 8) becomes of great interest. In a similar manner did Isaiah, who in all probability was of royal blood, condemn without hesitation the shortcomings and vices of the rulers and the court. An ancient tradition declares that Z. was of the tribe of Simeon, which would make it impossible for him to be of royal blood; but the origin and value of this tradition are uncertain.

Zephaniah lived in Judah; that he lived in Jerus is made probable by the statement in 1 4, "I will

cut off . . . from *this* place," as well as by his intimate knowledge of the topography of the city (1 10.11). For how long he continued

**3. Life** his prophetic activity we do not know, but it is not improbable that, as in the case of Amos, his public activity was short, and that, after delivering his message of judgment in connection with a great political crisis, he retired to private life, though his interest in reforms may have continued (2 K 23 2).

**II. Time.**—The title (1 1) places the prophetic activity of Zephaniah somewhere within the reign of Josiah, that is, between 639 and 608

**1. Date** BC. Most scholars accept this statement as historically correct. The most important exception is E. Koenig (*Einkl*, 252 ff), who places it in the decade following the death of Josiah. Koenig's arguments are altogether inconclusive, while all the internal evidence points toward the reign of Josiah as the period of Zephaniah's activity. Can the ministry of the prophet be more definitely located within the 31 years of Josiah? The latter's reign falls naturally into two parts, separated by the great reform of 621. Does the work of Zephaniah belong to the earlier or the later period?

The more important arguments in favor of the later period are: (a) Dt 28 29.30 is quoted in Zeph 1 13.15.17, in a manner which shows that the former book was well known, but, according to the modern view, the Deuteronomic Code was not known until 621, because it was lost (2 K 22 8). (b) The "remnant of Baal" (1 4) points to a period when much of the Baal-worship had been removed, which means subsequent to 621. (c) The condemnation of the "king's sons" (1 8) presupposes that at the time of the utterance they had reached the age of moral responsibility; this again points to the later period. These arguments are inconclusive: (a) The resemblances between Dt and Zeph are of such a general character that dependence of either passage on the other is improbable. (b) The expression in 1 4 bears an interpretation which made its use quite appropriate before 621 (Eiselen, *Minor Prophets*, 508). (c) "King's sons" may be equivalent to "royal princes," referring not to Josiah's children at all. The last two objections lose all force if the LXX readings are accepted (1 4, "names of Baal"; 1 8, "house of the king").

On the other hand, there are several considerations pointing to the earlier date: (a) The youth of the king would make it easy for the royal princes to go to the excesses condemned in 1 8.9. (b) The idolatrous practices condemned by Zephaniah (1 3-5) are precisely those abolished in 621. (c) The temper described in 1 12 is explicable before 621 and after the death of Josiah in 608, but not between 621 and 608, when religious enthusiasm was widespread. (d) Only the earlier part of Josiah's reign furnishes a suitable occasion for the prophecy. Evidently at the time of its delivery an enemy was threatening the borders of Judah and of the surrounding nations. But the only foes of Judah during the latter part of the 7th cent. meeting all the conditions are the Scythians, who swept over Western Asia about 625 BC. At the time the prophecy was delivered their advance against Egypt seems to have been still in the future, but imminent (1 14); hence the prophet's activity may be placed between 630 and 625, perhaps in 626. If this date is correct, Zephaniah and Jeremiah began their ministries in the same year.

Little can be said about the political conditions in Judah during the reign of Josiah, because the Bib. books are silent concerning them.

**2. Political Situation** Josiah seems to have remained loyal to his Assyr lord to the very end, even when the latter's prestige had begun to wane, and this loyalty cost him his life (2 K 23 29). As already suggested, the advance of the Scythians furnished the occasion of the prophecy. Many questions concerning these Scythians remain still unanswered, but this much is clear, that they



were a non-Sem race of barbarians, which swept in great hordes over Western Asia during the 7th cent. BC (see SCYTHIANS). The prophet looked upon the Scythians as the executioners of the Divine judgment upon his sinful countrymen and upon the surrounding nations; and he saw in the coming of the mysterious host the harbinger of the day of Jeh.

The Book of Zeph, the early discourses of Jer, and 2 K 21-23 furnish a vivid picture of the social, moral, and religious conditions in Judah at the time Zephaniah prophesied. Social injustice and moral corruption were widespread (3 1.3.7). Luxury and extravagance might be seen on every hand; fortunes were heaped up by oppressing the poor (1 8.9). The religious situation was equally bad. The reaction under Manasseh came near making an end of Jeh-worship (2 K 21). Amon followed in the footsteps of his father, and the outlook was exceedingly dark when Josiah came to the throne. Fortunately the young king came under prophetic influence from the beginning, and soon undertook a religious reform, which reached its culmination in the 18th year of his reign. When Zephaniah preached, this reform was still in the future. The Baalim were still worshipped, and the high places were flourishing (1 4); the hosts of heaven were adored upon the housetops (1 5); a half-hearted Jeh-worship, which in reality was idolatry, was widespread (1 5); great multitudes had turned entirely from following Jeh (1 6). When the cruel Manasseh was allowed to sit undisturbed upon the throne for more than 50 years, many grew skeptical and questioned whether Jeh was taking any interest in the affairs of the nation; they began to say in their hearts, "Jeh will not do good, neither will he do evil" (1 12). Conditions could hardly be otherwise, when the religious leaders had become misleaders (3 4). The few who, amid the general corruption, remained faithful would be insufficient to avert the awful judgment upon the nation, though they themselves might be "hid in the day of Jeh's anger" (2 3).

**III. The Book.**—The Book of Zeph falls naturally into two parts of unequal length. The first part (1 2-3 8) contains, almost exclusively, denunciations and threats; the second (3 9-20), a promise of salvation and glorification. The prophecy opens with the announcement of a world judgment (1 2,3), which will be particularly severe upon Judah and Jerus, because of idolatry (vs 4-6). The ungodly nobles will suffer most, because they are the leaders in crime (vs 8,9). The judgment is imminent (ver 7); when it arrives there will be wailing on every hand (vs 10, 11). No one will escape, even the indifferent skeptics will be aroused (vs 12,13). In the closing verses of ch 1, the imminence and terribleness of the day of Jeh are emphasized, from which there can be no escape, because Jeh has determined to make a "terrible end of all them that dwell in the land" (vs 14-18). A way of escape is offered to the meek; if they seek Jeh, they may be "hid in the day of Jeh" (2 1-3). Zeph 2 4-15 contains threats upon 5 nations, Philistia (vs 4-7), Moab and Ammon (vs 8-11), Ethiopia (ver 12), Assyria (vs 13-15). In 3 1 the prophet turns once more to Jerus. Leaders, both civil and religious, and people are hopelessly corrupt (vs 1-4), and continue so in spite of Jeh's many attempts to win the city back to purity (vs 5-7); hence the judgment which will involve all nations has become inevitable (ver 8). A remnant of the nations and of Judah will escape and find rest and peace in Jeh (vs 9-13). The closing section (vs 14-20) pictures the joy and exaltation of the redeemed daughter of Zion.

The authenticity of every verse in chs 2 and 3, and of several verses in ch 1, has been questioned by one or more scholars, but the passages rejected or questioned with greatest persistency are 2 1-3, 4-15 (esp. vs 8-11); 3 9, 10, 14-20. The principal objection to 2 1-3 is the presence in 2 3 of the expressions "meek of the earth," and "seek meekness." It is claimed that "meek" and "meekness" as religious terms are post-exilic. There can be no question that the words occur more frequently in post-exilic psalms and proverbs than in pre-exilic writings, but it cannot be proved, or even shown to be probable, that the words might not have been used in Zephaniah's day (cf Ex 10 3; Nu 12 3; Isa 2 9 ff; Mic 6 8). A second objection is seen in the difference of tone between these verses and ch 1. The latter, from beginning to end, speaks of the terrors of judgment; 2 1-3 weakens this by offering a way of escape. But surely, judgment cannot have been the last word of the prophets; in their thought, judgment always serves a disciplinary purpose. They are accustomed to offer hope to a remnant. Hence 2 1-3 seems to form the necessary completion of ch 1.

The objections against 2 4-15 as a whole are equally inconclusive. For vs 13-15, a date preceding the fall of Nineveh seems most suitable. The threat against Philistia (vs 4-7) also is quite intelligible in the days of Zephaniah, for the Scythians passed right through the Philistia territory. If Ethiopia stands for Egypt, ver 12 can easily be accounted for as coming from Zephaniah, for the enemies who were going along the Mediterranean coast must inevitably reach Egypt. But if it is insisted upon that the reference is to Ethiopia proper, again no difficulty exists, for in speaking of a world judgment Zephaniah might mention Ethiopia as the representative of the far south. Against vs 8-11 the following objections are raised: (a) Moab and Ammon were far removed from the route taken by the Scythians. (b) The "reproaches" of 2 8, 10 presuppose the destruction of Jerus (Ezk 25 3,6,8). (c) The attitude of the prophet toward Judah (vs 9,10) is the exact opposite of that expressed in ch 1. (d) The *kināh* meter, which predominates in the rest of the section, is absent from vs 8-11. (e) Ver 12 is the natural continuation of ver 9. These five arguments are by no means conclusive: (a) The prophet is announcing a world judgment. Could this be executed by the Scythians if they confined themselves to the territory along the Mediterranean Sea? (b) Is it true that the "reproaches" of 2 8, 10 presuppose the destruction of Jerus? (c) The promises in 2 7,8-10 are only to a remnant, which presupposes a judgment such as is announced in ch 1. (d) Have we a right to demand consistency in the use of a certain meter in oratory, and, if so, may not the apparent inconsistency be due to corruption of the text, or to a later expansion of an authentic oracle? (e) Vs 8-11 can be said to interrupt the thought only if it is assumed that the prophet meant to enumerate the nations in the order in which the Scythians naturally would reach their territory. From Philistia they would naturally pass to Egypt. But is this assumption warranted? While the objections against the entire paragraph are inconclusive, it cannot be denied that ver 12 seems the natural continuation of ver 9, and since vs 10 and 11 differ in other respects from those preceding, suspicion of the originality of these two verses cannot be suppressed.

Zeph 3 1-8 is so similar to ch 1 that its originality cannot be seriously questioned, but vs 1-8 carry with them vs 9-13, which describe the purifying effects of the judgment announced in vs 1-8. The present text of ver 10 may be corrupt, but if properly emended there remains insufficient reason for questioning vs 10 and 11. The authenticity of 3 14-20 is more doubtful than that of any other section of Zeph. The buoyant tone of the passage forms a marked contrast to the somber, quiet strain of vs 11-13; the judgments upon Judah appear to be in the past; vs 18-20 seem to presuppose a scattering of the people of Judah, while the purifying judgment of vs 11-13 falls upon the people in their own land; hence there is much justice in Davidson's remark that "the historical situation presupposed is that of Isa 40 ff." On the other hand, it must be borne in mind that the passage is highly poetic, that it presents an ideal picture of the future, in the drawing

of which imagination must have played some part, and it may be difficult to assert that the composition of this poem was entirely beyond the power of Zephaniah's enlightened imagination. But while the bare possibility of Zephaniah's authorship may be admitted, it is not impossible that 3 14-20 contains a "new song from God," added to the utterances of Zephaniah at a period subsequent to the fall of Jerus.

**IV. Teaching.**—The teaching of Zephaniah closely resembles that of the earlier prophetic books. Jeh is the God of the universe, a God of righteousness and holiness, who expects of His worshippers a life in accord with His will. Israel are His chosen people, but on account of rebellion they must suffer severe punishment. Wholesale conversion seems out of the question, but a remnant may escape, to be exalted among the nations. He adds little, but attempts with much moral and spiritual fervor to impress upon his contemporaries the fundamental truths of the religion of Jeh. Only a few points deserve special mention.

Earlier prophets had spoken of the day of Jeh; Amos (5 18-20) had described it in language similar to that employed by Zephaniah; but **1. The Day** the latter surpasses all his predecessors of **Jehovah** in the emphasis he places upon this terrible manifestation of Jeh (see **ESCHATOLOGY OF THE OT**). His entire teaching centers around this day; and in the Book of Zeph we find the germs of the apocalyptic visions which become so common in later prophecies of an eschatological character. Concerning this day he says (a) that it is a day of terror (1 15), (b) it is imminent (1 14), (c) it is a judgment for sin (1 17), (d) it falls upon all creation (1 2, 3; 2 4-15; 3 8), (e) it is accompanied by great convulsions in Nature (1 15), (f) a remnant of redeemed Hebrews and foreigners will escape from its terrors (2 3; 3 9-13).

The vision of the book is world-wide. The terrors of the day of Jeh will fall upon all. In the same manner from all nations converts will be won to Jeh (3 9, 10). These will not be compelled to come to Jerus to worship Jeh (Isa 2 2; Mic 4 1); they may worship Him "every one from his place" (2 11), which is a step in the direction of the utterance of Jesus in Jn 4 21.

The Messianic King is not mentioned by Zephaniah. Though he draws a sublime picture of the glories of the Messianic age (3 14-20), there is not a word concerning the person of the Messianic King. Whatever is done is accomplished by Jeh Himself.

**3. Messianic Prophecy** **LITERATURE.**—Comms. on the Minor Prophets by Ewald, Pusey, Keil, Orelli, G. A. Smith (*Expositor's Bible*); Driver (*New Cent.*); Eiselen; A. B. Davidson, *Comm. on Nah, Hab, and Zeph* (*Cambridge Bible*); A. F. Kirkpatrick, *Doctrine of the Prophets*; Eiselen, *Prophecy and the Prophets*; F. W. Farrar, "Minor Prophets," *Men of the Bible*; S. R. Driver, *LOT*; *HDB*, art. "Zeph, Book of"; *EB*, art. "Zeph."

F. C. EISELEN

**ZEPHATH**, zē'fath. See **HORMAH**.

**ZEPHATHAH**, zef'a-tha, **VALLEY OF** (צִפְתָּה, *ge'cē-phāthāh*; LXX κατὰ βορρᾶν, *katā borran*, reading צִפְתָּה, *cē-phāthāh*, instead of צִפְתָּה, *cē-phāthāh*): This is the place where Asa met and defeated the Ethiopians under Zerah (2 Ch 14 10). It is said to be at Mareshah. No name resembling this has been recovered there. Possibly, therefore, the LXX rendering is right, "in the ravine to the N. of Mareshah." In that case the battle may have been fought in *Wādī el-'Afranj*.

**ZEPHI**, zē'fi, **ZEPHO**, zē'fō (צִפְוֹ, *cē-phō*, perhaps "gaze," or "gazing," in 1 Ch 1 36; צִפְוֹ, *cē-phō*, the same meaning in Gen 36 11.15): A duke of

Edom. LXX has Σωφάρ, *Sōphár*, which Skinner (*Gen*, 431) says may be the original of Job's kind friend. In Gen 36 43 LXX has Ζαφωελ, *Zaphōel* (= צִפְוֹ, i.e. Zepho), for Iram. Skinner holds it probable that the two names, Zepho and Iram, were in the original text, thus making the number 12 (cf Lagarde, *Sept.-Stud.*, II, 10, l. 178; 37, l. 270; Nestle, *Margin.*, 12). Luc. has Σωφάρ, *Sōphár*, in Gen 36 11.15; Σεφρονή, *Sepphōnē*, in 1 Ch 1 37, and Σαφωλν, *Saphōlōn*, in Gen 36 43.

DAVID FRANCIS ROBERTS

**ZEPHON**, zē'fon. See **ZIPHION**.

**ZEPHONITES**, zē'fon-its, zē-fō'nits (צִפְוֹנִים, *ha-cē-phōnā*; ὁ Σαφωνί, *ho Saphōnī*, A omits): A family of Gadites descended from Zephon (Nu 26 15), who is called "Ziphion" in Gen 46 16.

**ZER**, zēr, zer (צֵר, *zēr*; in LXX the verse [Josh 19 35] reads καὶ αἱ πόλεις τευχῆρεις τῶν Τυρίων, κ.τ.λ., *kaí hai póleis teichēreís tōn Turíōn*, which implies a Heb text with צִרְיָה, *ha-cūrim*, "Tyrians"; this must be an error: One of the fortified cities in Naphtali, named between Ziddim (*Hattin*) and Hammath (*el-Hammeh*, S. of Tiberias). If the text is correct, it must have lain on the slopes W. of the Sea of Galilee. It is not identified.

**ZERAH**, zē'ra (זֵרַח, *zerah*, meaning uncertain):

(1) In Gen 38 30; 46 12; Nu 26 20; Josh 7 1. 18, 24; 22 20; 1 Ch 2 4, 6; 9 6; Neh 11 24; Mt 1 3, younger twin-son of Judah and Tamar, and an ancestor of Achan. In Nu 26 20; Josh 7 17 f he is the head of the Zerahites (also 1 Ch 27 11, 13). AV has "Zarah" in Gen 38 30; 46 12, and "Zarhites" for "Zerahites" in Nu, Josh and 1 Ch. See Curtis (*Chron.*, 84 f) for identification of Ezrahite with Zerahite.

(2) Edomites: (a) an Edomite chief (Gen 36 13, 17; 1 Ch 1 37); (b) father of an Edomite king (Gen 36 33; 1 Ch 1 44).

(3) Levites: (a) 1 Ch 6 21 (Heb ver 6); (b) 1 Ch 6 41 (Heb ver 26).

(4) Head of the Zerahites (Nu 26 13, AV "Zarhites"; 1 Ch 4 24). In Nu 26 13="Zohar" of Gen 46 10; Ex 6 15. See **ZOHAR**, (2).

(5) Cushite king (2 Ch 14 9). See next art.

DAVID FRANCIS ROBERTS

**ZERAH (THE ETHIOPIAN)** (זֵרַח הַכּוּשִׁי, *zerah ha-kūshī* [2 Ch 14 9]; Ζάρε, *Záre*): A generation ago the entire story of Zerah's conquest of Asa, coming as it did from a late source (2 Ch 14 9-15), was regarded as "apocryphal": "If the incredibilities are deducted nothing at all is left" (Wellhausen, *Prolegomena to the History of Israel*, 207, 208); but most modern scholars, while accepting certain textual mistakes and making allowance for customary oriental hyperbole in description, accept this as an honest historical narrative, "nothing" in the *Egypt* inscriptions being "inconsistent" with it (Nicol in *BD*; and of Sayce, *HCM*, 362-64). The name "Zerah" is a "very likely corruption" of "Usarkon" (*U-Serak-on*), which it closely resembles (see Petrie, *Egypt and Israel*, 74), and most writers now identify Zerah with Usarkon II, though the *Egypt* records of this particular era are deficient and some competent scholars still hold to Usarkon I (Wiedemann, Petrie, McCurdy, etc.). The publication by Naville (1891) of an inscription in which Usarkon II claims to have invaded "Lower and Upper Palestine" seemed to favor this Pharaoh as the victor over Asa; but the chronological question is difficult (*Eighth Memoir of the Egypt Exploration Fund*, 51). The title "the Cushite" (Heb) is hard to understand. There are several explanations

possible. (1) Wiedemann holds that this may refer to a real Ethiopian prince, who, though unrecorded in the monuments, may have been reigning at the Asa era. There is so little known from this era "that it is not beyond the bounds of probability for an Ethiopian invader to have made himself master of the Nile Valley for a time" (*Geschichte von Alt-Aegypten*, 155). (2) Recently it has been the fashion to refer this term "Cushite" to some unknown ruler in South or North Arabia (Winckler, Cheyne, etc.). The term "Cushite" permits this, for although it ordinarily corresponds to ETHIOPIA (q.v.), yet sometimes it designates the tract of Arabia which must be passed over in order to reach Ethiopia (Jeremias, *The OT in the Light of Ancient East*, I, 280) or perhaps a much larger district (see *BD*; *EB*; Hommel, *AHT*; Winckler, *KAT*, etc.). This view, however, is forced to explain the geographical and racial terms in the narrative differently from the ordinary Bib. usage (see Cheyne, *EB*). Dr. W. M. Flinders Petrie points out that, according to the natural sense of the narrative, this army must have been Egypt, for (a) after the defeat it fled toward Egypt, not eastward toward Arabia; (b) the cities around Gerar (probably Egypt towns on the frontier of Pal), toward which they naturally fled when defeated, were plundered; (c) the invaders were Cushim and Lubim (Libyans), and this could only be the case in an Egypt army; (d) Mareslah is a well-known town close to the Egypt frontier (*Hist of Egypt*, III, 242-43; cf. König, *Fünf neue arab. Landschaftsnamen im AT*, 53-57). (3) One of the Usarions might be called a "Cushite" in an anticipatory sense, since in the next dynasty (XXIII) Egypt was ruled by Ethiopian kings.

CAMDEN M. COBERN

**ZERAHIAH**, zer-a-hí'a (זְרַחְיָהוּ, *z'rah'yāh*, "Jeh hath risen" or "come forth"; LXX Ζαράϊα, *Zaraiá*, with variants):

(1) A priest of the line of Eleazar (1 Ch 6 6.51; Ezr 7 4).

(2) A head of a family, who returned with Ezra from Babylon (Ezr 8 4).

**ZERAHITES**, zē'ra-hits (זְרַחְיָהוּ, *ha-zarhī*; B, ó Zapaí, *ho Zaraiá*, A, ó Zapael, *ho Zarael*; AV Zarhites):

(1) A family of Simeonites (Nu 26 13).  
(2) Descendants of Zerach, son of Judah (Nu 26 20). To this family Achan belonged (Josh 7 17), as did also two of David's captains (1 Ch 27 11.13).

**ZERED**, zē'red (זֶרֶד, *zeredh*; B, Ζάρετ, *Záret*, A, Ζάρε, *Záre*; AV Zared [Nu 21 12]): This is the *nahal* or "torrent valley" given as the place where Israel encamped before they reached the Arnon (Nu 21 12). In Dt 2 13 f, the crossing of the brook Zered marks the end of the 38 years' desert wanderings. It has often been identified with *Wady el-'Ahsā*, which runs up from the southeastern corner of the Dead Sea. A fatal objection to this is that the host had entered the wilderness to the E. of Moab before they crossed the Zered (Nu 21 11), while *Wady el-'Ahsā* must have formed the southern boundary of Moab. We may conclude with certainty that one of the confluents of *Wady Kerak* is intended, but which, it is impossible now to say.

W. EWING

**ZEREDAH**, zer'ē-da, **ZEREDATH**, zer'ē-dath, **ZEREDATHA**, zer-ē-dā'tha, **ZERERAH**, zer'ē-ra, **ZERERATH**, zer'ē-rath. See ZARETHAN.

**ZERESH**, zē'resh (זֶרֶשׁ, *zeresh*, "gold," from the Pers; Σωσάρα, *Sōsára*): The wife of Haman (Est 5 10.14; 6 13), the vizier of Xerxes.

**ZERETH**, zē'reth (זֶרֶת, *zereth*, meaning unknown): A Judahite (1 Ch 4 7).

**ZERETH-SHAHAR**, zē'reth-shā'hār (זֶרֶת שָׁחַר, *zereth ha-shahār*; B, Σερεθὰ καὶ Σεῶν, *Seredá kat Seíōn*, A, Σάρθ καὶ Σίδρ, *Sárh kat Sídr*): A town in the territory of Reuben, "in the mount of the valley," named with Kiriathaim and Sibmah (Josh 13 19). Perhaps in the name *Hammát es-Sára*, attaching to the hot springs near Machaerus, there may be some echo of the ancient name; but no identification is possible.

**ZERI**, zē'rī (זֶרִי, *zeri*, meaning unknown): "Son" of Jeduthun, and a temple musician (1 Ch 25 3) = "Izri" of ver 11, which should be read here. See *IZRI*.

**ZEROR**, zē'rór (זֶרֹר, *zeror*, meaning unknown; LXX Ἀρέδ, *Aréd*, Luc., Σαρά, *Sará*): An ancestor of Kish and King Saul (1 S 9 1). See *ZUR*, (2).

**ZERUAH**, zē-rō'a (זֶרְעָה, *zeru'āh*, perhaps "leprous"): Mother of King Jeroboam I (1 K 11 26), LXX, B and Luc. omit the name in 11 26, but the long LXX after MT of 12 24 reads (ver 24b): "And there was a man of the hill-country of Ephraim, a servant of Solomon, and his name was Jeroboam, and the name of his mother was Sareisa [LXX Σαρεϊσά, *Sareisá*] a harlot." See ZARETHAN.

**ZERUBBABEL**, ze-rub'a-bel (זְרֻבְבָל, *zerub-bābhel*, probably a transliteration of the Bab name *Zeru-Babili*, "seed of Babylon"; Zopo-

1. **Name** זְרֻבְבָל, *Zorobábel*): Is commonly called the son of Shealtiel (Ezr 3 2.8; 6 2; Neh 12 1; Hag 1 1.12.14; Mt 1 12; Lk 3 27); but in 1 Ch 3 19 he is called the son of Pedaiah, the brother apparently of Shealtiel (Salathiel) and the son or grandson of Jeconiah. It is probable that Shealtiel had no children and adopted Zerubbabel; or that Zerubbabel was his levirate son; or that, Shealtiel being childless, Zerubbabel succeeded to the rights of sonship as being the next of kin.

Whatever may have been his blood relationship to Jeconiah, the Scriptures teach that Zerubbabel was his legal successor, of the 3d or

2. **Family** 4th generation. According to 1 Ch 3 19, he had one daughter, Shelomith, and seven sons, Meshullam, Hananiah, Hashubah, Ohel, Berechiah, Hasadiah and Jushab-hesed. In Mt 1 13 he is said to have been the father of Abiud (i.e. Abi-hud). As it is the custom in Arabia today to give a man a new name when his first son is born, so it may have been, in this case, that Meshullam was the father of Hud, and that his name was changed to Abiud as soon as his son was named Hud. In Lk 3 27, the son of Zerubbabel is called Rhesa. This is doubtless the title of the head of the captivity, the *rēsh g'luṭhā*, and would be appropriate as a title of Meshullam in his capacity as the official representative of the captive Jews. That Zerubbabel is said in the NT to be the son of Shealtiel the son of Neri instead of Jeconiah may be accounted for on the supposition that Shealtiel was the legal heir or adopted son of Jeconiah, who according to Jer 36 30 was apparently to die childless.

It has been shown in the article on Sheshbazzar that he and Zerubbabel may possibly have been the same person and that the name may

3. **Relation** have been Shamash-ban (or bun)-to Shesh-bazzar zer-Babili-ušur. It seems more probable, however, that Sheshbazzar, the prince of Judah, was governor under Cyrus and that Zerubbabel was governor under

Darius. The former, according to Ezr 1 8 and 5 14-16, laid the foundations, and the latter completed the building of the temple (Ezr 2 2.68; 4 2; Hag 1 14; Zec 4 9).

All that is known certainly about Zerubbabel is found in the canonical books of Zec, Hag and Ezr-Neh. According to these he and  
**4. History** Jeshua, the high priest, led up a band of captives from Babylon to Jerus and began rebuilding the temple in the second year of Darius Hystaspis. They first constructed the altar of burnt offerings, and afterward built a temple, usually called the Second Temple, much inferior in beauty to that of Solomon. According to Jos and the apocryphal Book of Ezr (1 Esd 3,4), Zerubbabel was a friend of Darius Hystaspis, having successfully competed before him in a contest whose object was to determine what was the strongest thing in the world—wine, kings, women, or truth. Zerubbabel, having demonstrated that truth was the mightiest of all, was called the king's "cousin," and was granted by him permission to go up to Jerus and to build the temple. Zerubbabel was also made a governor of Jerus, and performed also the duties of the *tirshatha*, an official who was probably the Pers collector of taxes. See TIRSHATHA.

R. DICK WILSON

**ZERUIAH**, zē-rōō-t'a, zē-rōō'ya (זְרוּיָא, זְרוּיָהּ, זְרוּיָהּ, זְרוּיָהּ) [*z'ruyāh*, זְרוּיָהּ, *z'ruyāh*] [2 S 14 1; 16 10], meaning uncertain; Σαρουά, *Sarouā*: In 2 S 2 18; 17 25; 1 Ch 2 16, and elsewhere where the names Joab, Abishai, occur. According to 1 Ch 2 16 a sister of David and mother of Joab, Abishai and Asahel, the two former being always referred to as sons of Zeruiah. This latter fact is explained by some as pointing to a type of marriage by which the children belonged to their mother's clan (cf Abimelech, Jgs 8 31; 9 1 ff); by others as being due to her husband's early death; and again as a proof of the mother in this case being the stronger personality. Either of the last two reasons may be the correct one, and plenty of parallels from the village names of boys today can be produced to illustrate both explanations. According to 2 S 2 32, her husband was buried at Bethlehem. In 2 S 17 25, "Abigail the daughter of Nahash" is said to be her sister. See ABIGAIL.  
DAVID FRANCIS ROBERTS

**ZETHAM**, zē'tham (זֶתָם, *zēthām*, meaning unknown): A Gershonite Levite (1 Ch 23 8; 26 22). In the second passage Curtis holds that "the sons of Jehiel" is a gloss; he points the MT to read "brethren" instead of "brother," and so has "Jehiel [ver 22] and his brethren, Zetham and Joel, were over the treasures."

**ZETHAN**, zē'than (זֶתָן, *zēthān*, perhaps "olive tree"): A Benjamite (1 Ch 7 10), but Curtis holds that he is a Zebulunite (*Chron.*, 145 ff).

**ZETHAR**, zē'thār (זֶתָר, *zēthar*; Oppert, *Est*, 25, compares Pers *zaitar*, "conqueror"; see *BDB*; LXX Ἀβαράζα, *Abatazá*): A eunuch of Ahasuerus (*Est* 1 10).

**ZEUS**, zūs (*Zeús*, *Zeús*, RVm; RV and AV Jupiter): The supreme god of Hellenic theology, "king of gods and of men." In 168 BC Antiochus Epiphanes, "who on God's altars danced," bent upon the thorough Hellenization of Judaea and Jerus, sent "an old man of Athens" (or "Geron an Athenian," RVm) to pollute the sanctuary in the temple at Jerus and to call it by the name of Jupiter Olympius, and that at Gerizim by the name of Jupiter Xenius (2 Macc 6 1 ff). Olympius, from Mt. Olympus, the home of the gods, is the favorite

epithet of Zeus, Zeus Olympius being to the Gr world what Jupiter Capitolinus was to the Rom. The same Antiochus commenced the splendid temple of Zeus Olympius, finished under Hadrian. Zeus is also frequently styled Xenius or "Protector of strangers" (*Jupiter hospitalis*) in classical literature. The epithet is here applied because the people of Gerizim—the Samaritans—were hospitable, probably an ironical statement of the author (cf Lk 9 52 f). Zeus is also in Acts 14 12 f RVm for JUPITER (q.v.).  
S. ANGUS

**ZIA**, zī'a (זִיָּא, זִיָּע, meaning uncertain): A Gadite, possibly the name of a Gadite clan (1 Ch 5 13).

**ZIBA**, zī'ba (זִיבָא, *zībā*, זִיבָא, *zībā*] [2 S 16 4a], meaning unknown; Σεϊβά, *Seibá*): A former servant or probably dependent of Saul's house (2 S 9 1 ff), who was brought to David when the king inquired if there was not a member of Saul's family that he could show kindness to (cf David's oath to Jonathan in 1 S 20 14 ff). Z. tells David of Mephibosheth (Meribbaal), Jonathan's son, who is thereupon taken to the king from Lodebar, E. of the Jordan, and given Saul's estate. Z. is also bidden to till the land and bring in its produce, and "it shall be food for thy master's son," according to MT in 2 S 9 10b; but LXX and Luc. have a better reading, "thy master's household." Mephibosheth himself is to eat at David's table. Z. is to be assisted in this by his sons and servants; he had 15 sons and 20 servants (9 10).

When David has to leave Jerus at the time of Absalom's revolt, Z. (2 S 16 1-4) takes two asses for members of the king's household to ride on, and 200 loaves and 100 clusters of raisins as provisions for the youths. When asked where Mephibosheth is, he accuses his master of remaining behind purposely in hopes that his father's kingdom would be restored to him. David then confers upon Z. his master's estate.

After Absalom's death, David sets out to return to Jerus from Mahanaim, E. of Jordan. Z. with his sons and servants, as we are told in a parenthesis in 2 S 19 17.18a (Heb vs 18.19a), by means of a ferry-boat goes backward and forward over Jordan, and thus enables the king's household to cross. But he has wrongly accused his master of treacherous lukewarmness toward David, for Mephibosheth meets the king on his return journey to Jerus (2 S 19 24-30 [Heb vs 25-31]) with signs of grief. When he is asked why he had not joined the king at the time of the latter's flight, he answers that Z. deceived him, "for thy servant said to him, Saddle me [so read in ver 26 (Heb ver 27) with LXX and Syr for MT 'I will have saddled me'] the ass." He then accuses Z. of falsehood, and David divides the estate between the two, although Mephibosheth is quite willing that Z. should retain the whole of it.  
DAVID FRANCIS ROBERTS

**ZIBEON**, zib'ē-on (זִיבְעוֹן, *zīb'ēn*, "hyena"; *HPN*, 95; Σεβεγών, *Sebegōn*): A Horite chief (Gen 36 2.14.20.24.29; 1 Ch 1 38.40); he is called the "Hivite" in Gen 36 2 where "Horite" should be read with vs 20.29. In Gen 36 2.14 Anah is said to be "the daughter of Zibeon," whereas LXX, Sam, Syr, Luc. have "the son of Z."; cf 1 Ch 1 38.40, where also Anah is Z.'s son.

**ZIBIA**, zib'i-a (זִיבְיָא, *zībhyā*, perhaps "gazelle"): A Benjamite (1 Ch 8 9).

**ZIBIAH**, zib'i-a (זִיבְיָהּ, *zībhyāh*, probably "gazelle"): A woman of Beersheba, mother of King Jehoash (Joash) of Judah (2 K 12 1 [Heb ver 2]; 2 Ch 24 1, BA Ἀβιά, *Abiá*).

**ZICHRI**, zik'ri (זִכְרִי, *zikhri*, meaning uncertain):

(1) Levites: (a) grandson of Kohath (Ex 6 21, where some AV edd read wrongly "Zithri"); (b) an Asaphite (1 Ch 9 15), called "Zabdi" in Neh 11 17, where LXX has Ζεχοφ, *Zechri*=Zichri, but LXX B other names; see ZABDI, (4); (c) a descendant of Eliezer (1 Ch 26 25).

(2) Benjamites: (a) 1 Ch 8 19; (b) 1 Ch 8 23; (c) 1 Ch 8 27; (d) Neh 11 9.

(3) Father of Eliezer, who was one of David's tribal princes (1 Ch 27 16).

(4) Father of Amasiah, "who willingly offered himself unto Jeh" (2 Ch 17 16).

(5) Father of Elishaphat, a captain in Jehoiada's time (2 Ch 23 1).

(6) "A mighty man of Ephraim," who when fighting under Pekah slew the son of Ahaz, the king of Judah (2 Ch 28 7).

(7) A priest in the days of Joiakim (Neh 12 17); the section, vs 14-21, is omitted by LXX B, with the exception of "of Maluchi" (ver 14); Luc. has Ζαχαρίας, *Zacharias*. DAVID FRANCIS ROBERTS

**ZIDDIM**, zid'im (צִידִים, *ha-ziddim*; B, τῶν Τυρίων, *ton Turiōn*, A omits): A fortified city in Naphtali (Josh 19 35), probably represented by the modern *Haftin*, about 5 miles N.W. of Tiberias, in the opening of the gorge that breaks down seaward N. of *Kurūn Haftin*, the traditional Mount of Beatitudes.

**ZID-KIJAH**, zid-ki'ja. See ZEDEKIAH, 5.

**ZIDON**, zi'don, **ZIDONIANS**, zi-dō'ni-anz. See SIDON, SIDONIANS.

**ZIF**, zif. See ZIV.

**ZIHA**, zi'ha (צִיחָא, *zihā'*, צִיחָא, *zihā'* [Neh 7 46], meaning unknown): An overseer of Nethinim (Neh 11 21) who are called (Ezr 2 43; Neh 7 46) "the children [or sons] of Ziha." LXX BA omits Neh 11 20 f, LXX has Ζιάλ, *Sial*, Luc., Ζιααύ, *Siaaü*; in 7 46 LXX B, Σηά, *Sēā*, A, Οιαά, *Oiaā*, Luc., Σουλαί, *Soulai*; in Ezr 2 43 LXX B, Σουθιά, *Southiā*, A, Σουαά, *Souaā*, Luc., Σουδαεί, *Soudaei*.

**ZIKLAG**, zik'lag (צִקְלָג, *ziklāg*, צִקְלָג, *ziklāg* [2 S 1 1], צִקְלָג, *ziklāg* [1 Ch 12 1.20]; usually in LXX Σεκελάκ, *Sekelāk*, or Σικελάγ, *Sikelāg*): A town assigned (Josh 19 5; 1 Ch 4 30) to Simeon, but in Josh 15 31 named, between Horeb and Madmannah, as one of the cities of the Negeb of Judah, "toward the border of Edom." It is said (1 S 27 6) to have remained a royal city. In Neh 11 28 it is in the list of towns rehhabited by the returning children of Judah. Its chief associations are with David. Achish the Phili king of Gath gave it to David as a residence (1 S 27 6 f; 1 Ch 12 1.20); it was raided by the Amalekites, on whom David took vengeance and so recovered his property (1 S 30 14.26); here the messenger who came to announce Saul's death was slain (2 S 1 1; 4 10).

The site of this important place is not yet fixed with certainty. Conder proposed *Zuheilika*, a ruin 11 miles S.S.E. of Gaza, and 4 miles N. of *Wady es-Sheriā*, which may be the "Brook Besor" (1 S 30 9.10.21); Rowland (1842) proposed *Asūj*, a heap of ruins S. of Beersheba and 7 miles to the E. of Bered. Neither site is entirely satisfactory. See Williams, *Holy City*, I, 463-68; BR, II, 201, PEF, 288, Sh XX.

E. W. G. MASTERMAN

**ZILLAH**, zil'a (צִילָה, *zillah*; Σελλά, *Sellā*): One of Lamech's wives (Gen 4 19.22.23). The name is perhaps connected with *çel*, "shadow."

**ZILLETHAI**, zil'e-thi, zil-e'thā-i (צִילְתַּי, *çil'thay*, meaning uncertain; AV Zilthai):

(1) A Benjamite (1 Ch 8 20).

(2) A Manassite who joined David at Ziklag (1 Ch 12 20 [Heb ver 21]).

**ZILPAH**, zil'pa (צִלְפָּה, *zilpāh*, meaning uncertain; Ζελφά, *Zelphā*): The ancestress of Gad and Asher (Gen 30 10.12; 35 26; 46 18), a slave girl of Leah's, given her by Laban (29 24; 30 9). In Ezk 48 the Zilpah tribes have the 5th division toward the south of Pal and the 6th to the north, a slightly more favorable position than that of the Bilhah tribes.

**ZILTHAI**, zil'thi, zil'thā-i. See ZILLETHAI.

**ZIMMAH**, zim'a (צִמָּה, *zimmāh*, perhaps "device," "plan"): A Gershonite Levite (1 Ch 6 20 [Heb ver 5]; also in 6 42 [Heb ver 27]; 2 Ch 29 12). See CURTIS, *Chron.*, 130, 134 ff.

**ZIMRAN**, zim'ran (צִמְרָן, *zimirān*, from צִמְרֵן, *zemer*, "wild sheep" or "wild goat," the ending -ān being gentile; Skinner, *Gen*, 350): Son of Abraham and Keturah (Gen 25 2; 1 Ch 1 32). The various MSS of the LXX give the name in different forms, e.g. in Gen A\*, Ζεμπράν, *Zebrán*, Σ, Ζεμπράν, *Zembrán*, A, Ζεμβράμ, *Zembrám*, D<sup>91</sup>, Ζουμπράν, *Zombrán*, and Luc., Ζεμπράν, *Zembrán*; in Ch, B has Ζεμπράν, *Zembrán*, A, Ζεμπράν, *Zembrán*, Luc., Ζεμπράν, *Zembrán* (cf Brooke and McLean's ed of the LXX for Gen).

Hence some have connected the name with Zabram of Ptol. vi.7.5. W. of Mecca; others with the Zamareni of Pliny (*Ant.* vi.158) in the interior of Arabia; but according to Skinner and E. Meyer (see Gunkel, *Gen*<sup>8</sup>, 261) these would be too far south. Curtis (*Chron.*, 72) says the name is probably to be identified with the "Zimri" of Jer 25 25. It would then be the name of a clan, with the mountain sheep or goat as its totem. See TOTEMISM.

DAVID FRANCIS ROBERTS

**ZIMRI**, zim'ri (צִמְרִי, *zimirī*, "wild sheep" or "wild goat"; in 1 Macc AV Ζαμβρέτ, *Zambret*, Σ, Ζαμβρέτ, *Zambret*):

(1) A Simeonite prince (Nu 25 14; 1 Macc 2 26), slain by Phinehas, Aaron's grandson. Nu 25 1-5 records how the Israelites, while they were at Shittim, began to consort with Moabite women and "they [i.e. the Moabite women] called the people unto the sacrifices of their gods" (ver 2), i.e. as explained by ver 5 to take part in the immoral rites of the god Baal-peor. Moses is bidden to have the offenders punished. The next paragraph (vs 6-9) relates how the people engage in public mourning; but while they do this Zimri brings in among his brethren a Midianitess. Phinehas sees this and goes after Zimri into the *kubbāh*, where he slays the two together, and thus the plague is stayed (vs 6-9).

The connection between these two paragraphs is difficult; Moabite women are mentioned in the first, a Midianitess in the second; the plague of vs 8 f is not previously referred to, although it seems clear that the plague is the cause of the weeping in ver 6. The sequel, vs 16-18, makes the second paragraph have something to do with Baal-peor. Critics assign vs 1-5 to JE, vs 6-18 to P.

It seems, however, that the two accounts refer to similar circumstances. This is evident if the meaning of *kubbāh* in ver 8 be as the Vulg renders it, *lupinar*, "a house of ill-repute." The difficulty is that the word only occurs here in the OT, but it has that meaning in New Heb (see Gray, *Nu*, 385; BDB, however, translates it "a large vaulted tent." While one narrative says the women were Moabitesses and the other Midianitesses, the latter section presupposes something like the account in the former; and the point is that Zimri, at the very time that the rest of the people publicly mourned

because of a plague that was due to their own dealings with foreign women, brought a Midianite woman among the people, possibly to be his wife, for he was a prince or chief, and she was the daughter of a Midianite chief. It may be urged that if this be the case, there was nothing wrong in it; but according to Heb ideas there was, and we only need to remember the evil influence of such marriages as those entered into by Solomon, or esp. that of Ahab with Jezebel, to see at any rate a Heb justification for Zimri's death.

Nu 31 describes the extermination of the Midianites at the bidding of Moses. All the males are slain by the Israelites (ver 7), but the women are spared. Moses is angry at this: "Have ye saved all the women alive? Behold, these caused the children of Israel, through the counsel of Balaam, to commit trespass against Jeh in the matter of Peor, and so the plague was among the congregation of Jeh" (vs 15 f). Here we find, although the chapter is a *Midhrash* (see Gray, *Nu*, 417 ff), that the Hebrews themselves connected the two events of ch 25, but in addition the name of Balaam is also introduced, as again in ver 8, where he is said to have been slain along with the kings of Midian. See further Dt 4 3, and Driver's note on the verse. See BAAL-PEOR; BALAAM; PEOR.

(2) A king of Israel (1 K 16 8-20). See special article.

(3) A Judahite "son" of Zerah (1 Ch 2 6) = "Zabdi" of Josh 7 1.17 f. See ZABDI, (1).

(4) A Benjamite, descendant of King Saul (1 Ch 8 36; 9 42).

(5) In Jer 25 25, where "all the kings of Zimri" are mentioned along with those of Arabia (ver 24) and Elam and the Medes. The name is as yet unidentified, although thought to be that of a people called ZIMRAN (q.v.) in Gen 25 2.

DAVID FRANCIS ROBERTS

**ZIMRI** (זִמְרִי, *zimri*; LXX Ζαμβρη, *Zambrei*, Ζαμβρη, *Zambri*): The 5th king of Israel, but who occupied the throne only seven days (1 K 16 9-20). Zimri had been captain of half the chariots under Elah, and, as it seems, made use of his position to conspire against his master. The occasion for his crime was furnished by the absence of the army, which, under the direction of Omri, was engaged in the siege of the Phili town Gibbethon. While Elah was in a drunken debauch in the house of his steward Arza, who may have been an accomplice in the plot, he was foully murdered by Zimri, who ascended the throne and put the remnant of Elah's family to death, thus fulfilling the prophecy of Jehu concerning the house of Baasha. However, the conspiracy lacked the support of the people, for word of the crime no sooner reached Gibbethon, than the army raised Omri to the throne of Israel. Omri at once hastened to Tirzah and captured the place, which as it seems offered little resistance. Zimri resolved to die as king, and accordingly set fire to the palace with his own hands, and perished in the flames that he had kindled. Thus came to an ignominious end the short reign which remained as a blot even upon the blood-stained record of the deeds of violence that ushered in the change of dynasties in the Northern Kingdom, for the foul crime was abhorred even among arch plotters. When Jehu entered Jezreel he was met with Jezebel's bitter taunt, "Is it peace, thou Zimri, thy master's murderer?" (2 K 9 31). The historian too, in the closing formula of the reign, specially mentions "his treason that he wrought."

S. K. MOSIMAN

**ZIN**, zin (זֵין, *zin*; Σιν, *Sin*):

(1) A town in the extreme S. of Judah, on the line separating that province from Edom, named between the ascent of Akkrabbim and Kadesh-barnea (Nu 34 4; Josh 15 3). It must have lain somewhere between *Wady el-Fikra* (the ascent of

Akrabbim?) and 'Ain Kadis (Kadesh-barnea); but the site has not been recovered.

(2) The Wilderness of Zin is the tract deriving its name from the town (Nu 34 3). It is identified with the wilderness of Kadesh in Nu 33 36; while in other places Kadesh is said to be in the wilderness of Zin (Nu 20 1; 27 14; Dt 32 51). We may take it that the two names refer to the same region. The spies, who set out from Kadesh-barnea, explored the land from the wilderness of Zin northward (Nu 13 21; cf 32 8). It bordered with Judah "at the uttermost part of the south" (Josh 15 1). In this wilderness Moses committed the offence which cost him his hope of entering the promised land (Nu 27 14; Dt 32 51). It is identical with the uplands lying to the N. and N.W. of the wilderness of Paran, now occupied by the 'Azāzimeh Arabs.

W. EWING

**ZINA**, zī'na. See ZIZAH.

**ZION**, zī'on (יְרוּשָׁלַיִם, *ḡiyon*; Σιών, *Sidon*):

1. Meaning of the Word
2. The Zion of the Jebusites
3. Zion of the Prophets
4. Zion in Later Poetical Writings
5. Omission of Name by Some Writers
6. The Name "Zion" in Christian Times

LITERATURE

A name applied to Jerus, or to certain parts of it, at least since the time of David. Nothing certain is known of the meaning. Gesenius

1. **Meaning** and others have derived it from a Heb of the Word root יָבֵשׁ, *ḡāhāh*, "to be dry"; Delitzsch from יָבֵשׁ, *ḡiwwāh*, "to set up," and Wetzstein from יָבֵשׁ, *ḡin*, "to protect." Gesenius finds a more hopeful suggestion in the Arab. equivalent *shwal*, the Arab. *shwal* signifying "ridge of a mountain" or "citadel," which at any rate suitably applies to what we know to have been the original Zion (cf Smith, *HGHL*, s.v.).

Considerable confusion has been caused in the past by the want of clear understanding regarding the different sites which have respectively been called "Zion" during the centuries. It will make matters clearer if we take the application of the name: in David's time; in the early Prophets, etc; in late poetical writings and in the Apocrypha; and in Christian times.

Jerus (in the form Uru-sa-lim) is the oldest name we know for this city; it goes back at least 400 years before David. In 2 S 5 6-9,

2. **The Zion** "The king and his men went to Jerus of the against the Jebusites. . . . Nevertheless David took the stronghold of Zion; the same is the city of David . . . . And David dwelt in the stronghold, and called it the city of David." It is evident that Zion was the name of the citadel of the Jebusite city of Jerus. That this citadel and incidentally the then city of Jerus around it were on the long ridge running S. of the Temple (called the south-eastern hill in the art. JERUSALEM, III, [3] [q.v.]) is now accepted by almost all modern scholars, mainly on the following grounds:

(1) *The near proximity of the site to the only known spring*, now the "Virgin's Fount," once called GIBON (q.v.). From our knowledge of other ancient sites all over Pal, as well as on grounds of common-sense, it is hardly possible to believe that the early inhabitants of this site with such an abundant source at their very doors could have made any other spot their headquarters.

(2) *The suitability of the site for defence*.—The sites suited for settlement in early Can. times were all, if we may judge from a number of them now known, of this nature—a rocky spur isolated on

three sides by steep valleys, and, in many sites, protected at the end where they join the main mountain ridge by either a valley or a rocky spur.

(3) *The size of the ridge*, though very small to our modern ideas, is far more in keeping with what we know of fortified towns of that period than such an area as presented by the southwestern hill—the traditional site of Zion. Mr. Macalister found by actual excavation that the great walls of Gezer, which must have been contemporaneous with the Jebusite Jerus, measured approximately 4,500 ft. in circumference. G. A. Smith has calculated that a line of wall carried along the known and inferred scarps around the edge of this southeastern hill would have an approximate circumference of 4,250 ft. The suitability of the site to a fortified city like Gezer, Megiddo, Socco, and other sites which

(traditional Zion) to the Temple is to go down. (b) Hezekiah constructed the well-known Siloam tunnel from Gihon to the Pool of Siloam. He is described (2 Ch 32 30) as bringing the waters of Gihon "straight down on the west side of the city of David." (c) Manasseh (2 Ch 33 14) built "an outer wall to the city of David, on the west side of Gihon, in the valley" (i.e. *naḥal*—the name of the Kedron valley).

Zion, renamed the City of David, then originally was on this eastern ridge. But the name did not stay there. It would almost seem as if the name was extended to the Temple site when the ark was carried there, for in the pre-exilic Prophets the references to Zion all appear to have referred to the Temple Hill. To quote a few examples:

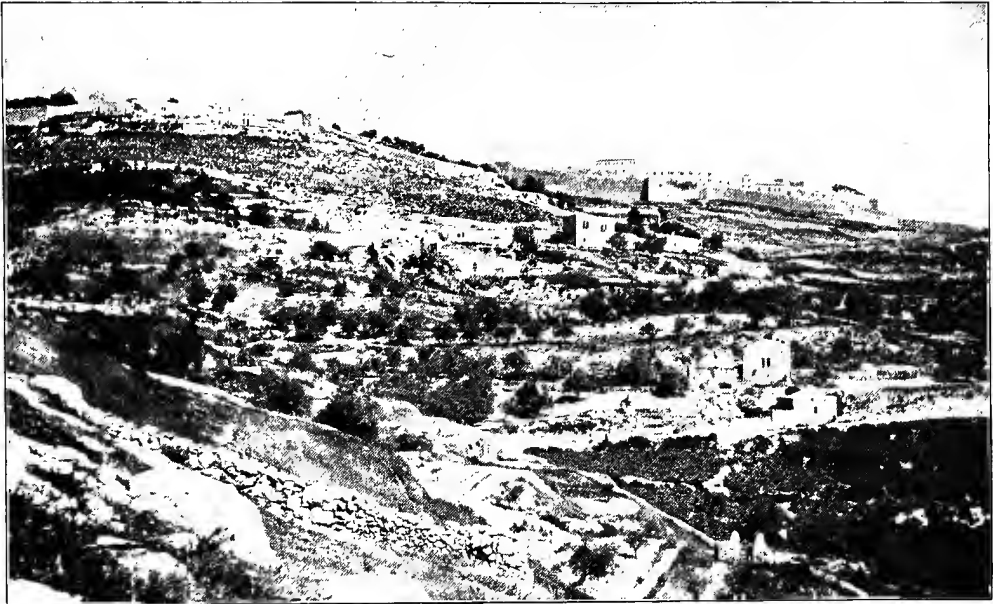

SLOPE OF ZION—TYROPŒON VALLEY AT RIGHT.

have been excavated, strikes anyone familiar with these places.

(4) *The archaeological remains* on these hills found by Warren and Professor Guthe, and more particularly in the recent excavations of Captain Parker (see JERUSALEM), show without doubt that this was the earliest settlement in pre-Israelite times. Extensive curves and rock-cuttings, cave-dwellings and tombs, and enormous quantities of early "Amorite" (what may be popularly called "Jebusite") pottery show that the spot must have been inhabited many centuries before the time of David. The reverse is equally true; on no other part of the Jerus site has any quantity of such early pottery been found.

(5) *The Bible evidence* that Zion originally occupied this site is clear. It will be found more in detail under the heading "City of David" in the art. JERUSALEM, IV, (5), but three points may be mentioned here: (a) The Ark of the Covenant was brought up out of the city of David to the Temple (1 K 8 1; 2 Ch 5 2), and Pharaoh's daughter "came up out of the city of David unto her house which Solomon had built for her"—adjacent to the Temple (1 K 9 24). This expression "up" could not be used of any other hill than of the lower-lying eastern ridge; to go from the southwestern hill

"And Jeh will create over the whole habitation of mount Zion, and over her assemblies, a cloud and smoke by day, and the shining of a flaming fire by



Citadel of Zion.

night" (Isa 4 5); "Jeh of hosts, who dwelleth in mount Zion" (Isa 8 18); "Let us go up to Zion unto Jeh our God" (Jer 31 6); "Jeh will reign over them in mount Zion" (Mic 4 7). All these, and numbers more, clearly show that at that time Zion was the Temple Hill.

In many of the later writings, particularly poetical references, Zion appears to be the equivalent of Jerus; either in parallelism (Ps 102 21; Am 1 2; Mic 3 10.12; Zec 1 14.17; 8 3; Zeph 3 16) or alone (Jer 3 14; Lam 5 11); even here many of the references will do equally well for the Temple Hill. The term "Daughter of Zion" is applied to the captive Jews (Lam 4 22), but in other references to the people of Jerus (Isa 1 8; 52 2; Jer 4 31, etc). When we come to the Apocrypha, in 2 Esd there are several references in which Zion is used

4. Zion in Later Poetical Writings and Apocrypha



Stairway in Ancient Wall—Modern Zion.

for the captive people of Judah (2 40; 3 2.31; 10 20.39. 44), but "Mount Zion" in this and other books (e.g. 1 Macc 4 37.60; 5 54; 6 48.62, etc) is always the Temple Hill.

It has been pointed out as a curious and unaccountable exception that in Ezk as well as in Ch, Ezr and Neh, there is no mention of Zion, except the incidental reference to David's capture of the Jebusite fort. The references in the other Prophets and the Pss are so copious that there must be some religious reason for this. The Chronicler (2 Ch 3 1), too, alone refers to the Temple as on Mount Moriah. It is also noticeable that only in these books (2 Ch 27 3; 33 14; Neh 3 26f; 11 21) does the name "Ophel" appear as a designation of a part of the southeastern hill, which apparently might equally fitly have been termed Zion. See ORNEL. Jos never uses the name "Zion" nor does it occur in the NT, except in two quotations (He 12 22; Rev 14 1).

Among the earlier Christian writers who mention "Zion," Origen used it as equivalent to the Temple Hill, but in the 4th cent. writers commence to localize it up the southern part of the western hill. It was a period

6. The Name "Zion" in Christian Times

when Bib. topography was settled in a very arbitrary manner, without any scientific or critical examination of the evidence, and this tradition once established remained, like many such traditions, undisputed until very recent years. To Rev. W. F. Birch belongs much of the credit for the promulgation of the newer views which now receive the adherence

of almost every living authority on the topography of Jerus.

LITERATURE.—See esp. ch vi in Smith's *Jerusalem*; for a defence of the older view see Kuenmmel, *Materialien z. Topog. des alt. Jerus.*

E. W. G. MASTERMAN

**ZIOR**, zī'or (צִיֹּר, צִיֹּר; צִיֹּר; Σῶρθ, Sōrth, or Σιῶρ, Siōr): A town in the hill country of Judah (Josh 15 54); probably *Si'air*, 4½ miles N.N.E. of Hebron where the *Mukām 'Aīsa* (Tomb of Esau) is now shown. It is a considerable village surrounded by cultivated land; a spring exists in the neighborhood; there are rock-cut tombs showing it is an ancient site (*PEF*, III, 309, Sh XXI).

**ZIPH**, zif (צִיִּף, zīph; Ὀζειβ, Ozēib, or Ζίφ, Zīph):

(1) A town in the hill country of Judah, mentioned along with Maon, Carmel and Jutah (Josh 15 55). It is chiefly celebrated in connection with the earlier history of David: "David . . . remained in the hill-country in the wilderness of Ziph" (1 S 23 14.15.24; 26 2); the Ziphites (1 S 23 19; 26 1; cf Ps 54 title) sought to betray him to Saul, but David escaped. Ziph was fortified by Rehoboam (2 Ch 11 8). The name also occurs in 1 Ch 2 42; 4 16. In connection with this last (cf ver 23) it is noticeable that Ziph is one of the four names occurring on the Heb stamped jar handles with the added לַמֶּלֶךְ, *la-melekh*, "to the king."

The site is *Tell Zīf*, 4 miles S.E. of Hebron, a conspicuous hill 2,882 ft. above sea-level; there are cisterns and, to the E., some ruins (*PEF*, III, 312, 315).

(2) A town in the Negeb of Judah (Josh 15 24), site unknown. E. W. G. MASTERMAN

**ZIPH** (צִיִּף, zīph, meaning unknown):

(1) A grandson of Caleb (1 Ch 2 42); LXX *Zelph*, *Zēiph*.

(2) A son of Jehallelel (1 Ch 4 16). In LXX Cod. A reads Ζιφαί, *Zīphat*, but B has the totally different form Ἀμαχεί, *Amāchei*.

**ZIPHAH**, zī'fa (צִיִּפָּה, zīphāh, a fem. form of "Ziph"): A Judahite, "son" of Jehallelel. The name being fem. may be a dittography of the previous Ziph (1 Ch 4 16).

**ZIPHIMS**, zif'imz: In title of Ps 54 AV for RV **ZIPHITES** (q.v.).

**ZIPHION**, zif'i-on (צִיִּפְיֹן, zīphyōn, "gaze" [?]) [*BDB*]: A "son" of Gad (Gen 46 16) = "Zephon" of Nu 26 15. See **ZAPHON**; **ZEPHONITES**.

**ZIPHITES**, zif'its. See **ZIPH**.

**ZIPHRON**, zif'ron. See **SIBRAIM**.

**ZIPPOR**, zip'or (צִפּוֹר, zīppōr; in Nu 22 4; 23 18; צִפּוֹר, zīppōr, "bird," "swallow" [*HFN*, 94]): Father of Balak, king of Moab (Nu 22 2.10.16; Josh 24 9; Jgs 11 25).

**ZIPPORAH**, zi-pō'ra, zip'ō-ra (צִפּוֹרָה, zīppōrāh; Σεπφώρα, *Sepphōra*): The Midianite wife of Moses, daughter of Jethro, also called Hobab, and probably granddaughter of Reuel, a priest of Midian at the time Moses fled from Egypt, later succeeded at his death by Jethro, or Hobab (Ex 2 21.22; 4 25.26; 18 2-6).

Whether or not Z. was the "Cushite woman" (Nu 12 1) is a much-mooted question. There is little ground for anything more than speculation on the subject. The use of the words, "Cushite woman" in the mouth of Aaron and Miriam may



have been merely a description of Z. and intended to be opprobrious, or they may have been ethnic in character and intended to denote another woman whom Moses had married, as suggested by Ewald (*Gesch. des Volkes Israel*, II, 252). The former view seems the more probable. The association of Midian and Cushan by Habakkuk (3 7) more than 700 years afterward may hardly be adduced to prove like close relationship between these peoples in the days of Moses.

M. G. KYLE

**ZITHRI**, zith'ri. See SITHRI.

**ZIV**, ziv (זִיב, *ziw*; AV Zif): The 2d month of the old Heb calendar, corresponding to Iyyar of the Jewish reckoning in later times. It is mentioned in 1 K 6 1.37. See CALENDAR.

**ZIZ**, ziz, ASCENT OF (מַעְלֵה הַצִּיָּן, *ma'ālēh ha-ṣīṭ*; Ἀσαέ, *Hasaé*, Ἀσσά, *Hasísá*): A pass in the wilderness of Judaea (2 Ch 20 16) leading from Hazazon-tamar (En-gedi, ver 2). This is generally identified with *Wādī Haṣaṣa*, a valley by which the ancient road from En-gedi runs toward Jerus. At any rate, an echo of the ancient name survives here: possibly the actual ascent was the present steep pass from En-gedi to the plateau above. See PEF, Sh XXI.

**ZIZA**, zī'za (צִיָּא, *zīzā*), probably a childish reduplicated abbreviation or a term of endearment [Curtis, *Chron.*, 369, quoting Nöldeke in *EB*, III 3294]:

(1) A Simeonite chief (1 Ch 4 37).

(2) A son of King Rehoboam, his mother being a daughter or granddaughter of Absalom (2 Ch 11 20).

(3) A probable reading for ZIZAH (q.v.).

**ZIZAH**, zī'za (צִיָּא, *zīzāh*; see ZIZA): A Gershonite Levite (1 Ch 23 11); in ver 10 the name is "Zina" (צִיָּא, *zīnā*), while LXX and Vulg have "Ziza" (Ζιζά, *Zizá*) in both verses, and one Heb MS has *zīzā* in ver 10. We should then probably read *zīzā* in both verses, i.e. "Ziza."

**ZOAN**, zō'an (צֹאן, *ṣō'an*; Ταύς, *Tanís*):

1. Situation
2. OT Notices
3. Early History
4. Hyksos Monuments
5. Hyksos Population
6. Hyksos Age
7. Description of Site

The name is supposed to mean "migration" (Arab. *ṣān*). The site is the only one connected with the

history of Israel in Egypt, before the  
**1. Situation** exodus, which is certainly fixed, being identified with the present village of *Sān* at the old mouth of the Bubastic branch of the Nile, about 18 miles S.E. of Damietta. It should be remembered that the foreshore of the Delta is continually moving northward, in consequence of the deposit of the Nile mud, and that the Nile mouths are much farther N. than they were even in the time of the geographer Ptolemy. Thus in the times of Jacob, and of Moses, Zoan probably lay at the mouth of the Bubastic branch, and was a harbor, Lake Menzaleh and the lagoons near Pelusium having been subsequently formed.

The city is only once noticed in the Pent (Nu 13 22), as having been built seven years after Hebron, which existed in the time of Abraham.

**2. OT Notices** Zoan was certainly a very ancient town, since monuments of the VIth Egypt Dynasty have been found at the site. It has been thought that Zoar on the border of Egypt (Gen 13 10) is a clerical error for Zoan, but the LXX reading (*Zógora*) does not favor this

view, and the place intended is probably the fortress *Zar*, or *Zor*, often mentioned in Egypt texts as lying on the eastern borders of the Delta. Zoan is noticed in the Prophets (Isa 19 11.13; 30 4; Ezk 30 14), and its "princes" are naturally mentioned by Isaiah, since the capital of the XXIIIrd Egypt Dynasty (about 800 to 700 BC) was at this city. In Ps 78 12.43 the "field [or pastoral plain] of Zoan" is noticed as though equivalent to the land of GOSHEN (q.v.).

Zoan was the capital of the Hyksos rulers, or "shepherd kings," in whose time Jacob came into

Egypt, and their monuments have been found at the site, which favors the conclusion that its plain was that

"land of Rameses" (Gen 47 11; Ex 12 37; see RAAMESSES) where the Hebrews had possessions under Joseph. It is probably the site of Avaris, which lay on the Bubastic channel according to Jos quoting Manetho (*Cap*, I, xiv), and which was rebuilt by the first of the Hyksos kings, named Salatis; for Avaris is supposed (Brugsch, *Geog.*, I, 86-90, 278-80) to represent the Egypt name of the city *Ha-uar-t*, which means "the city of movement" (or "flight"), thus being equivalent to the Sem Zoan or "migration." It appears that, from very early times, the pastoral peoples of Edom and Pal were admitted into this region. The famous picture of the *Amu*, who bring their families on donkeys to Egypt, and offer the Sinaitic ibex as a present, is found at *Beni Hasan* in a tomb as old as the time of Usertasen II of the XIIth Dynasty, before the Hyksos age. A similar immigration of shepherds (see PITHOM) from Aduma (or Edom) is also recorded in the time of Menepthah, or more than four centuries after the expulsion of the Hyksos by the XVIIIth, or Theban, Dynasty.

Besides the name of Pepi of the VIth Dynasty, found by Burton at Zoan, and many texts of the

XIIth Dynasty, a cartouche of Apepi

**4. Hyksos Monuments** (one of the Hyksos kings) was found by Mariette on the arm of a statue apparently of older origin, and a sphinx also bears the name of *Khian*, supposed to have been an early Hyksos ruler. The Hyksos type, with broad cheek bones and a prominent nose, unlike the features of the native Egyptians, has been regarded by Virchow and Sir W. Flower as Turanian, both at Zoan and at Bubastis; which agrees with the fact that Apepi is recorded to have worshipped no Egypt gods, but only Set (or *Sutekh*), who was also adored by Syrian Mongols (see HITITES). At Bubastis this deity is called "Set of Rameses," which may indicate the identity of Zoan with the city Rameses.

In the 14th cent. BC the city was rebuilt by Rameses II, and was then known as Pa-Ramessu. The Hyksos rulers had held it for 500 years according to Manetho, and were expelled after 1700

**5. Hyksos Population** BC. George the Syncellus (*Chronographia*, about 800 AD) believed that Apepi (or Apophis) was the Pharaoh under whom Joseph came to Egypt, but there seems to have been more than one Hyksos king of the name, the latest being a contemporary of Ra-Sekenen of the XIIIth Dynasty, shortly before 1700 BC. Manetho says that some supposed the Hyksos to be Arabs, and the population of Zoan under their rule was probably a mixture of Sem and Mongolic races, just as in Syria and Babylonia in the same ages. According to Brugsch (*Hist of Egypt*, II, 233), this population was known as *Men* or *Menti*, and came from Assyria E. of Ruten or Syria. This perhaps connects them with the Minyans of Matlene, who were a Mongolic race. This statement occurs in the great table of nations, on the walls of the Edfu temple.

The Hyksos age corresponds chronologically with that of the 1st Dynasty of Babylon, and thus with the age of the Heb patriarchs Abraham and Jacob

**6. Hyksos Age** —a time when the power of Babylon was supreme in Syria and Pal. It is very natural, therefore, that, like other Sem tribes even earlier, these patriarchs should have been well received in the Delta by the Hyksos Pharaohs,

and equally natural that, when Aahmes, the founder of the XVIIIth Egypt Dynasty, took the town of Avaris and expelled the Asiatics, he should also have oppressed the Hebrews, and that this should be intended when we read (Ex 1 8) that "there arose a new king over Egypt, who knew not Joseph." The exodus, according to the OT dates, occurred in the time of the XVIIIth Dynasty (see Exodus) when Israel left Goshen. The later date advocated by some scholars, in the reign of Meneptah of the XIXth Dynasty, hardly agrees with the monumental notice of the immigration of Edomites into the Delta in his reign, which has been mentioned above; and in his time Egypt was being invaded by tribes from the N. of Asia.

Zoan, as described by Rev. G. J. Chester (*Mem. Survey W. Pal.*, Special Papers, 1881, 92-96), is now only a small hamlet of mud huts in a sandy waste, W. of the huge mounds of its ancient temple; but, besides the black granite sphinx, and other statues of the Hyksos age, a red sandstone figure of Rameses II and obelisks of granite have been excavated, one representing this king adoring the gods; while the names of Amen, Tum and Mut appear as those of the deities worshipped, in a beautiful chapel in the temple, carved in red sandstone, and belonging to the same age of prosperity in Zoan.

C. R. CONDER

**ZOAR**, zō'ar (צֹרַר, צֹרֵר, צֹרָר; LXX usually Σηγόρ, *Sēgōr*, Ζόγορα, *Zōgora*): The name of the city to which Lot escaped from Sodom (Gen 19 20-23.30), previously mentioned in 13 10; 14 2,8, where its former name is said to have been Bela. In 19 22, its name is said to have been given because of its littleness, which also seems to have accounted for its being spared. The location of Zoar has much to do with that of the cities of the Plain or Valley of Siddim, with which it is always connected. In Dt 34 3, Moses is said to have viewed "the Plain of the valley of Jericho the city of palm trees, unto Zoar," while in Isa 15 5 and Jer 48 4 (where the LXX reads unto "Zoar," instead of "her little ones") it is said to be a city of Moab. The traditional location of the place is at the south end of the Dead Sea. Jos says (*BJ*, IV, viii, 4) that the Dead Sea extended "as far as Zoar of Arabia," while in *Ant.* I, xi, 4, he states that the place was still called Zoar. Eusebius (*Onom.*, 261) locates the Dead Sea between Jericho and Zoar, and speaks of the remnants of the ancient fertility as still visible. Ptolemy (v. 17.5) regards it as belonging to Arabia Petraea. The Arabian geographers mention it under the name *Zughar*, *Sughar*, situated 1° S. of Jericho, in a hot and unhealthy valley at the end of the Dead Sea, and speak of it as an important station on the trade route between Akkabah and Jericho. The Crusaders mention "Segor" as situated in the midst of palm trees. The place has not been definitely identified by modern explorers, but from Gen 19 19-30 we infer that it was in the plain and not in the mountain. If we fix upon the south end of the Dead Sea as the Vale of Siddim, a very natural place for Zoar and one which agrees with all the traditions would be at the base of the mountains of Moab, E. of *Wady Ghurundel*, where there is still a well-watered oasis several miles long and 2 or 3 wide, which is probably but a remnant of a fertile plain once extending out over a considerable portion of the shallow south end of the Dead Sea when, as shown elsewhere (see DEAD SEA), the water level was considerably lower than now.

Robinson would locate it on the northeast corner of *el-Lisān* on the borders of the river Kerak, but this was done entirely on theoretical grounds which would be met as well in the place just indicated, and which is generally fixed upon by the writers who regard the Vale of Siddim as at the south end of the Dead Sea. Conder, who vigorously maintains that the Vale of Siddim is at the north end of the Dead Sea, looks favorably upon the theory of Rev. W. H. Birch that the place is represented by the present *Tell Shaghar*, a white rocky mound at the foot of the Moab Mountains, a mile E. of *Beth-haram*

(*Tell er-Rāmeḥ*), 7 miles N.E. of the mouth of the Jordan, a locality remarkable for its stone monuments and well-supplied springs, but he acknowledges that the name is more like the Christian Segor than the original Zoar.

GEORGE FREDERICK WRIGHT

**ZOBAB**, zō'ba (צֹבָב, *zōbhāh*; Σουβά, *Soubá*): The name is derived by Halévy from *z'hōbhāh* as referring to its supplies of "bright yellow" brass; but this word might be more appropriately used to contrast its cornfields with white Lebanon. Zobah was an Aramaean kingdom of which we have the first notice in Saul's wars (1 S 14 47).

(1) *David's first war.*—When David sought to extend his boundary to the Euphrates, he came into contact with its king Hadadezer, and a great battle was fought in which David took many prisoners. Damascus, however, came to the rescue and fresh resistance was made, but a complete rout followed and great spoil fell to the victor, as well as access to the rich copper mines of Tebah and Berothai. Toi, king of Hamath, who had suffered in war with Hadadezer, now sent his son on an embassy with greetings and gifts to David (2 S 8 3-12; 1 Ch 18 3-12). See Ps 60, title.

(2) *David's second war.*—During David's Ammonite war, the enemy was strengthened by alliance with Zobah, Maacah and Beth-rehob, and Israel was attacked from both N. and S. at the same time. The northern confederation was defeated by Joab, but Hadadezer again gathered an army, including levies from beyond the Euphrates. These, under Shobach the captain of the host, were met by David in person at Helam, and a great slaughter ensued, Shobach himself being among the slain (2 S 10 6-19, AV "Zoba"; 1 Ch 19 3-19). Rezon, son of Eliada, now broke away from Hadadezer and, getting possession of Damascus, set up a kingdom hostile to Israel (1 K 11 23-25). Solomon seems (2 Ch 8 3) to have invaded and subdued Hamath-zobah, but the text, esp. LXX, is obscure.

(3) *Geographical position.*—We can now consider the vexed question of the situation and extent of Aram-zobah. (See SYRIA, 4, [10].) In addition to the OT references we have the Assyrian name lists. In these Šubiti is placed between Kui and Zemar, and, where it is otherwise referred to, a position is implied between Hamath and Damascus. It would thus lie along the eastern slopes of Anti-Lebanon extending thence to the desert, and in the north it may have at times included Emesa (modern *Homs*) around which Nöldeke would locate it. Damascus was probably a tributary state till seized by Rezon. Winckler would identify it with another Šubiti, a place in the Hauran mentioned by Assurbanipal on the Rassam Cylinder vii, lines 110-12. This latter may be the native place of Igal, one of David's "thirty" (2 S 23 36), who is named among eastern Israelites.

The kingdom of Zobah in addition to its mineral wealth must have been rich in vineyards and fruitful fields, and its conquest must have added greatly to the wealth and power of Israel's king.

W. M. CHRISTIE

**ZOBEBAH**, zō-bē'ba (צֹבְבָה, *ha-zōbhēbhāh*, meaning uncertain): A Judahite name with the article prefixed (1 Ch 4 8); some would read "Jabez" instead as in ver 9.

**ZOHAR**, zō'hār (צֹהָר, *zōḥar*, meaning uncertain):

(1) Father of Ephron the Hittite (Gen 23 8; 25 9).

(2) "Son" of Simeon (Gen 46 10; Ex 6 15) = "Zerah" of Nu 26 13; 1 Ch 4 24; see ZERAH, 4.

(3) In 1 Ch 4 7, where K<sup>e</sup>rē is "and *zōḥar*" for K<sup>e</sup>thibh, *yīḡhar*, RV "Izhar," AV wrongly "Jezoar."

**ZOHELETH**, zō'hē-leth, **THE STONE OF** (זֶהֱלֶתֶת, 'ebhen ha-zōheleth, "serpent's stone"): "And Adonijah slew sheep and oxen and fatlings by the stone of Zoheleth, which is beside En-rogel!" (1 K 1 9). Evidently this was a sacred stone—probably a *maqṣebhāh* such as marked a Can. sanctuary. A source of "living water" has always in the Sem world been a sacred place; even today at most such places, e.g. at *Bīr ʿEyyūb*, the modern representative of En-rogel, there is a *mīhrāb* and a platform for prayer. The stone has disappeared, but it is thought that an echo of the name survives in *ez-Zehwēleh*, the name of a rocky outcrop in the village of Siloam. Because the name is particularly associated with an ascent taken by the woman coming from the Virgin's Fount, to which it is adjacent, some authorities have argued that this, the Virgin's Fount, must be *En-rogel*; on this see **EN-ROGEL**; **GIHON**. Against this view, as far as *ez-Zehwēleh* is concerned, we may note: (1) It is by no means certain that the modern Arab. name—which is used for similar rocky spots in other places—is really derived from the Heb.; (2) the name is now applied to quite different objects, in the Heb to a stone, in the Arab. to a rocky outcrop; (3) the name is *not* confined to this outcrop near the Virgin's Fount alone, but applies, according to at least some of the *fellāhīn* of Siloam, to the ridge along the whole village site; and (4) even if all the above were disproved, names are so frequently transferred from one locality to another in Pal that no argument can be based on a name alone.

E. W. G. MASTERMAN

**ZOHETH**, zō'heth (זֹהֶתֶת, *zōhēth*, meaning unknown): A Judahite (1 Ch 4 20). The name after "Ben-zoheth" at the end of the verse has fallen out. See **BEN-ZOHETH**.

**ZOÖLOGY**, zō-ol'ō-ji: A systematic list of the animals of the Bible includes representatives of the principal orders of mammals, birds and reptiles, and not a few of the lower animals. For further notices of animals in the following list, see the articles referring to them:

**Mammals:**

- PRIMATES: Ape
- INSECTIVORA: Hedgehog. MOLE (q.v.) not found in Pal
- CHIROPTERA: Bat
- CARNIVORA:
  - (a) *Felidae*, Cat, Lion, Leopard
  - (b) *Hyaenidae*, Hyena
  - (c) *Canidae*, Dog (incl. Greyhound), Fox, Jackal, Wolf
  - (d) *Mustelidae*, Ferret, Badger, Marten (s.v. CAT)
  - (e) *Ursidae*, Bear
- UNGULATA:
  - (a) Odd-toed: Horse, Ass, Mule, Rhinoceros
  - (b) Even-toed non-ruminants: Swine, Hippopotamus (Behemoth)
  - (c) Ruminants:
    - (1) *Bovidae*, Domestic Cattle, Wild Ox or Unicorn, Domestic Sheep, Domestic Goat, Sinaitic Ibez (s.v. GOAT), Persian Wild Goat (s.v. CHAMOIS), Gazelle, Arabian Oryx (s.v. ANTELOPE), Chamois
    - (2) *Cervidae*, Roe Deer, Fallow Deer, Red Deer (s.v. DEER)
    - (3) *Camelidae*, Camel

- PROBOSCIDEA: Elephant
- HYRACOIDEA: Coney
- SIRENIA: Dugong (s.v. BADGER)
- CETACEA: Whale, Dolphin, Porpoise
- RODENTIA: Mouse, Mole-Rat (s.v. MOLE), Porcupine, Hare

**Birds:**

- PASSERES: Sparrow, Swallow, Raven, Hoopoe, Night-Hawk
- RAPTORES: Great Owl, Little Owl, Horned Owl, Eagle, Vulture, Gier-Eagle, Osprey, Kite, Glede, Hawk, Falcon
- COLUMBAE: Dove, Turtle-Dove
- GALLINAE: Cock, Partridge, Quail, Peacock
- GRALLATORES: Crane, Heron, Stork
- STEGANOPODES: Pelican, Cormorant
- RATITAE: Ostrich

**Reptiles:**

- CROCODILIA: Crocodile (Leviathan)
- CHELONIA: Tortoise
- OPHIDIA: Serpent, Fiery Serpent, Adder, Asp, Viper (s.v. SERPENT)
- LACERTILIA: Lizard, Great Lizard, Gecko, Chameleon, Land Crocodile, Sand Lizard (s.v. LIZARD)

**Amphibians:**

- Frog

**Fishes:**

- Fish (in general)

**Mollusks:**

- Snail, Murex (Purple)

**Insects:**

- HYMENOPTERA: Ant, Bee, Hornet
- LEPIDOPTERA: Clothes-Moth (s.v. MOTH), Silk-Worm, Worm (Larva)
- SIPHONAPTERA: Flea
- DIPTERA: Fly
- RHYNCHOTA: Louse, Scarlet-Worm
- ORTHOPTERA: Grasshopper, Locust (s.v. INSECTS)

**Arachnida:**

- Spider, Scorpion

**Coelenterata:**

- Coral

**Porifera:**

- Sponge

Some interesting problems arise in connection with the lists of clean and unclean animals in Lev and Dt. The list of clean animals in Dt 14 4-5 is as follows:

HEB	AV	RV	TRISTRAM
1. <i>shōr</i> . . . .	Ox	Ox	Ox
2. <i>shē</i>			
3. <i>k'sābhīm</i> .	Sheep	Sheep	Sheep
4. <i>shē 'izzīm</i> .	Goat	Goat	Goat
5. <i>ayyāl</i> . . . .	Hart	Hart	Red deer
6. <i>g'bhī</i> . . . .	Roebuck	Gazelle	Gazelle
7. <i>yahmūr</i> . . . .	Fallow deer	Roebuck	Bubale
8. <i>dāshōn</i> . . . .	Wild goat	Wild goat	Ibez
9. <i>g'ā</i> . . . . .	Pygarg	Pygarg	Addax
10. <i>zemer</i> . . . .	Wild ox	Antelope	Oryx
	Chamois	Chamois	Barbary sheep

Probably the most valuable modern work on Bible animals is Tristram's *Natural History of the Bible*, published in 1867 and to a great extent followed in RV and in articles in various Bib. encyclopaedias. In the table given above, RV really differs from Tristram only in 6, 8 and 10. Hart is the male of the red deer, the ibex is a kind of wild goat, and the oryx is a kind of antelope. The first three in the table are domestic animals whose identification is not questioned. The other seven are presumably wild animals, regarding every one of which there is more or less uncertainty. 'Akkō, *dāshōn* and *zemer* occur only in this passage, *g'ā* only here and in Isa 51 20. 'Ayyāl occurs 22 t, *g'bhī* 16 t, *yahmūr* only twice. The problem is to find seven ruminant mammals to correspond to these names. The camel (ver 7) is excluded as unclean. The gazelle, the Sinaitic ibex, and the Pers wild goat are common. The roe deer was fairly common in Carmel and Southern Lebanon 20 years ago, but is now nearly or quite extinct. The fallow deer exists in Mesopotamia, and Tristram says that he saw it in Galilee, though the writer is inclined to question the accuracy of the observation. The oryx is fairly common in North-western Arabia, approaching the limits of Edom. Here, then, are six animals, the gazelle, ibex, Pers wild goat, roe deer, fallow deer, and oryx, whose existence in or near Pal is undisputed.

The bubale, addax and Barbary sheep of Tristram's list are North African species which the writer believes do not range as far E. as Egypt, and which he believes should therefore be excluded. In Asia Minor are found the red deer, the chamois and the Armenian wild sheep, but there is no proof that any of these ever ranged as far S. as Pal. The bison exists in the Caucasus, and the wild ox, *urus* or aurochs, seems to be depicted in Assyrian sculptures. The buffalo is found in Pal, but is believed to have been introduced since Bible times. The Tartarian roe is named *Cervus pygargus*, and there is a South African antelope named *Bubalis pygargus*, but the pygarg of EV

has no real existence. The word means "white-rumped," and might apply to various deer and antelopes.

To complete the list of seven we are therefore driven to one of the following: the red deer, the chamois, the Armenian wild sheep, the bison and the aurochs, no one of which has a very good claim to be included. The writer considers that the roe, which has been the commonest deer of Pal, is the 'ayyāl

(cf Arab. <sup>أَيْل</sup>, 'ayyil, "deer"). *Ḥḥbī* is very near to Arab. <sup>ظَبِي</sup>, *ḥabi*, "gazelle," and, with its 16

occurrences in the OT, may well be that common animal. There is reason to think that *yahmūr* is the name of a deer, and the writer prefers to apply it to the fallow deer of Mesopotamia, as being more likely to have inhabited Pal than the red deer of Asia Minor. There is little evidence regarding 'akḥō, which occurs only here. The etymology is uncertain. LXX has *τραγέλαφος*, *tragélaφος*, "goat-stag." Tg and Syr VSS, according to BDB, have ibex. *Yā'ēl* (Job 39 1; Ps 104 18; 1 S 24 2), EV "wild goat," is quite certainly the ibex, but it is possible that 'akḥō may be another name for the same animal, *yā'ēl* not occurring in this list. In BDB *dīshōn* is derived from <sup>דָּשָׁן</sup>, *dūsh*, "to tread," and is considered to be a kind of wild goat. Since we have assigned 'akḥō to the ibex, we may then assign this name to the other wild goat of the country, the Pers wild goat or pasang. *T'ō* is in RV antelope and in LXX *δρυξ*, *dryx*, "oryx." This is a possible identification which suits also Isa 51 20, and does not preclude the possibility that the *re'em*, AV "unicorn," RV "wild-ox," may also be the oryx. The oryx is known to the Arabs under at least three names, the

commonest of which, <sup>بَقَرُ الْوَحْشِ</sup>, *baqr el-wahsh*, means "wild-ox." Under CHAMOIS, the writer suggests that *zemer* may be the pasang or Pers wild goat, which is figured in that article. There is little to choose in the assignment of the names, but as *dīshōn* has here been provisionally assigned to the pasang, nothing better is left for *zemer* than the "chamois" of EV, the claims of which are referred to above.

The list of unclean animals is considered in the art. on LIZARD.

Prophecies of the desolation of Babylon and Edom in Isa 13 21,22; 34 11-15 contain names of animals, some of which present apparently insuperable difficulties. See under JACKAL and SATYR. The Book of Job contains some remarkable references to animals, esp. in chs 39, 40, 41: to the wild goat, the wild ass, the wild ox, the ostrich, the horse, the hawk, the behemoth and the Leviathan.

Prov 30 contains some curious allusions to natural history:

" . . . Things which are too wonderful for me . . .

The way of an eagle in the air;  
The way of a serpent upon a rock [see EAGLE; WAY];

There are four things which are little upon the earth,  
But they are exceeding wise:  
The ants are a people not strong,  
Yet they provide their food in the summer;  
The conies are but a feeble folk,  
Yet they make their houses in the rocks;  
The locusts have no king,  
Yet go they forth all of them by bands;  
The lizard taketh hold with her hands,  
Yet is she in kings' palaces.

There are three things which are stately in their march,  
Yea, four which are stately in going:  
The lion, which is mightiest among beasts,  
And turneth not away for any;  
The greyhound; the he-goat also;  
And the king against whom there is no rising up."

An interesting grouping is found in the prophecy in Isa 11 6-8 (cf 65 25): "And the wolf shall dwell with the lamb, and the leopard shall lie down with the kid; and the calf and the young lion and the fatling together; and a little child shall lead them. And the cow and the

bear shall feed; their young ones shall lie down together; and the lion shall eat straw like the ox. And the sucking child shall play on the hole of the asp, and the weaned child shall put his hand on the adder's den."

The fauna of Pal is mainly European and Asiatic, but resembles in some important points the fauna of Africa. The Syrian coney is not found elsewhere and its only near allies are the conies of Africa. The gazelle and oryx belong to the group of antelopes which is esp. African. The lion and leopard range throughout Africa and Southwest Asia. The ostrich is found outside of Africa only in Arabia. Some of the smaller birds, as for instance the sun-bird, have their nearest allies in Africa. The fish of the Sea of Tiberias and the Jordan present important resemblances to African fishes. The same is true of some of the butterflies of Pal. Allying the fauna of Pal with that of Europe and North Asia may be noted the deer, bear, wolf, fox, hare and others. The ibex and Pers wild goat constitute links with central Asia, which is regarded as the center of distribution of the goat tribe.

The fauna of Pal has undoubtedly changed since Bible times. Lions have disappeared, bears and leopards have become scarce, the roe deer has nearly or quite disappeared within recent years. It is doubtful whether the aurochs, the chamois and the red deer were ever found in Pal, but if so they are entirely gone. The buffalo has been introduced and has become common in some regions. Domestic cats, common now, were perhaps not indigenous to ancient Palestine. In prehistoric times, or it may be before the advent of man, the glacial period had an influence upon the fauna of this country, traces of which still persist. On the summits of Lebanon are found two species of butterfly, *Pieris callidice*, found also in Siberia, and *Vanessa urticae*, common in Europe. When the glacial period came on, these butterflies with a host of other creatures were driven down from the N. When the cold receded northward they moved back again, except for these, and perhaps others since become extinct, which found the congenial cold in ascending the mountains where they became isolated. Syria and Pal were never covered with a sheet of ice, but the famous cedar grove of Lebanon stands on the terminal moraine of what was once an extensive glacier.

ALFRED ELY DAY

ZOPHAH, zō'fa (צוֹפָה, *ḥōphah*, meaning uncertain): An Asherite (1 Ch 7 35,36).

ZOPHAI, zō'fi, zō'fā-i (צוֹפַי, *ḥōphay*, meaning uncertain): In 1 Ch 6 26 (Heb ver 11)=Zuph, <sup>זופ</sup>, of ver 35 (Heb ver 20), and 1 S 1 1. See ZUPH, (1).

ZOPHAR, zō'far (צוֹפָר, *ḥōphar*, meaning doubtful, supposed from root meaning "to leap"; <sup>צוֹפָר</sup>, *Sōphār*): One of the three friends of Job who, hearing of his affliction, make an appointment together to visit and comfort him. He is from the tribe of Naamah, a tribe and place otherwise unknown, for as all the other friends and Job himself are from lands outside of Pal, it is not likely that this place was identical with Naamah in the W. of Judah (Josh 15 41). He speaks but twice (chs 11, 20); by his silence the 3d time the writer seems to intimate that with Bildad's 3d speech (ch 25; see under BILDAD) the friends' arguments are exhausted. He is the most impetuous and dogmatic of the three (cf 11 2,3; 20 2,3); stung to passionate response by Job's presumption in maintaining that he is wronged and is seeking light from God. His words are in a key of intensity amounting to reckless exaggeration. He is the first to accuse Job directly

of wickedness; averring indeed that his punishment is too good for him (11 6); he rebukes Job's impious presumption in trying to find out the unsearchable secrets of God (11 7-12); and yet, like the rest of the friends, promises peace and restoration on condition of penitence and putting away iniquity (11 13-19). Even from this promise, however, he reverts to the fearful peril of the wicked (ver 20); and in his 2d speech, outdoing the others, he presses their lurid description of the wicked man's woes to the extreme (20 5-29), and calls forth a straight contradiction from Job, who, not in wrath, but in dismay, is constrained by loyalty to truth to acknowledge things as they are. Zophar seems designed to represent the wrong-headedness of the *odium theologicum*. JOHN FRANKLIN GENUNG

**ZOPHIM**, zō'fīm, **THE FIELD OF** (צֹפִים זֹפִים, *s'dhēh zōphīm*; εἰς ἀγροῦ σκοπιάν, *eis agroū skopían*): The place on the top of Pisgah to which Balak took Balaam, whence only a part of the host of Israel could be seen (Nu 23 14). Perhaps we should simply translate "field of watchers." Conder draws attention to the name *Tal'at es-Sufa* attached to an ascent leading up to the ridge of *Nebā* from the N. Here possibly is a survival of the old name. For *Ramathaim-zophim* see RAMAH.

**ZORAH**, zō'ra (צֹרְאָה, *zor'āh*; Σαραά, *Sarad*): A city on the border of Dan, between Eshtaol and Ir-shemesh (Josh 19 41); the birthplace of Samson (Jgs 13 2.25); near here too he was buried (Jgs 16 31); from here some Danites went to spy out the land (Jgs 13 2.11). In Josh 15 33 it is, with Eshtaol, allotted to Judah, and after the captivity it was reinhabited by the "children of Judah" (Neh 11 29, AV "Zareah"). It was one of the cities fortified by Rehoboam (2 Ch 11 10). It is probable that it is mentioned under the name *Tsarkha* along with *Aialuna* (Aijalon; 2 Ch 11 10) in the Am Tab (No. 265, Petrie) as attacked by the Khabiri.

It is the modern *Sur'a*, near the summit of a lofty hill on the north side of the *Wādy es-Surūr* (Vale of Sorek). The summit itself is occupied by the *Mukām Nebi Sāmit*, overhung by a lofty palm, and there are many remains of ancient tombs, cisterns, wine presses, etc., around. From here *Eshū'a* (Eshtaol), *Ain Shems* (Beth-shemesh) and *Tibnah* (Timnah) are all visible. See *PEF*, III, 158, Sh XVII. E. W. G. MASTERMAN

**ZORATHITES**, zō'rath-īts (צֹרְאִתִּים, *zor'āthī*; Σαραθαῖοι, *Sarathathōi* [1 Ch 2 53, AV "Zareathites"]; B, ὁ Ἀραθαί, *ho Arathēi*, A, ὁ Σαραθί, *ho Sarathī* [4 2]): The inhabitants of Zorah, who are said to be descended from Kiriath-jearim families.

**ZOREAH**, zō'rē-ā (צֹרְעָה, *zor'āh*): AV of Josh 15 33 for ZORAH (q.v.).

**ZORITES**, zō'rīts (צֹרְיִים, *zor'ī*; B, ὁ Ἡσαρηεῖ, *ho Hēsarsei*, A, ὁ Ἡσαραεῖ, *ho Hēsaraēi*): In 1 Ch 2 54 for "Zorites" we should probably read ZORATHITES (q.v.). These formed a half of the inhabitants of MANAHATH (q.v.).

**ZOROASTRIANISM**, zō-rō-as'tri-an-iz'm:

- I. HISTORY
- Sources
- II. RELATION TO ISRAEL
- 1. Influence on Occident
- 2. Popular Judaism
- 3. Possible Theological Influence
- 4. Angelology and Demonology
- 5. Eschatology
- 6. Messiah
- 7. Ethics
- 8. Summary

LITERATURE

**I. History.**—The sacred book of the Persians, the Avesta, is a work of which only a small part has survived. Tradition tells that the Avestan

**Sources** MSS have suffered one partial and two total destructions (at the hands of Turanians, Macedonians, and Mohammedans, respectively), and what remains seems to be based on a collection of passages derived from oral tradition and arranged for liturgical purposes at the time of the first Sassanians (after 226 AD). None the less, a portion (the Gathas) of the present work certainly contains material from Zoroaster himself and much of the remainder of the Avesta is pre-Christian, although some portions are later. Outside of the Avesta there is an extensive literature written in Pahlavi. Most of this in its final form belongs to the 9th Christian cent., or to an even later date, but in it there is embodied much very early matter. Unfortunately criticism of these sources is as yet in a very embryonic condition. The Gr historians, esp. Plutarch and Strabo, are naturally of great importance, but the chief Gr work (that of Theopompus) is lost.

For a general account of Zoroastrianism, see PERSIAN RELIGION.

**II. Relation to Israel.**—Zoroastrianism was an active, missionary religion that has exerted a profound influence on the world's thought, 1. Influence all the more because in the West (at on Occident any rate) Ahura Mazda was not at all a jealous god, and Mazdeism was always quite ready to enter into syncretism with other systems. But this syncretistic tendency makes the task of the historian very delicate. None of the three great streams that swept from Persia over the West—Mithraism, Gnosticism, and Manicheism—contained much more than a Mazdean nucleus, and the extrication of Mazdean from other (esp. older Magian and Bab) elements is frequently impossible. Yet the motive force came from Zoroaster, and long before the Christian era "Magi" were everywhere (as early as 139 BC they were expelled from Rome; cf RAB-MAG; BRANCH). Often, doubtless, charlatans, they none the less brought teachings that effected a far-reaching modification of popular views and produced an influence on so basic a writer as Plato himself.

Within the period 538-332 BC (that Cyrus was a Zoroastrian seems now established) Israel was under the rule of Mazdeans, and Mazdeism had a profound influence on at least the popular Judaism conceptions was inevitable. It appears clearly in such works as *Tob* (*Expos T*, XI, 257 ff), and *Hystaspis* (*GJV*, ed 4, III, 592-95), in many Talmudic passages (*ZDMG*, XXI, 552-91), certain customs of the Essenes, various anti-demoniac charms (see EXORCISM; SORCERY), and, perhaps, in the feast of Purim. And the stress laid on the prophetic ability of the Magi in Mt 2 1-12 is certainly not without significance. But the important question is the existence or extent of Mazdean influence on the formal Jewish religion.

As a matter of fact, after Israel's contact with Persia the following elements, all known to Mazdeism, appear, and apparently for the 3. Possible first time: (1) a formal angelology, Theological with six (or seven) archangels at the Influence head of the developed hierarchy; (2) these angels not mere companions of God but His intermediaries, established (often) over special domains; (3) in the philosophical religion, a corresponding doctrine of hypostases; (4) as a result, a remoter conception of God; (5) a developed demonology; (6) the conception of a supreme head (Satan) over the powers of evil; (7) the doctrine of immortality; (8) rewards or punishments for the soul immediately after death; (9) a schematic eschatology,

esp. as regards chronological systems; (10) a superhuman Messiah; (11) bodily resurrection; (12) a rationalized, legalistic conception of God's moral demands.

In this list Mazdean influence may be taken as certain in points (1), (2), (5), (6). Of course belief in angels and (still more) in demons had always existed in Israel, and a tendency to classification is a natural product of increased culture. But the thoroughness and rapidity of the process and the general acceptance of its principles show something more than cultural growth (of the influence of pseudo-Dionysius on Christianity). In particular, the doctrine of patrons (angelic or demoniac) seems to find no expression in the preëxilic religion. Nor was the incorporation into a single being, not only of phases, but of the whole power of evil, a necessary growth from the earlier religion; the contrast between 2 S 24 1 and 1 Ch 21 1 shows a sharp alteration in viewpoint. On the other hand, the dualism that Ahriman was to explain produced no effect on Israel, and God remained the Creator of all things, even of Satan. See SATAN; ANTI-CHRIST. (3) presents a problem that still needs proper analysis. The Zoroastrian abstractions may well have stimulated Jewish speculation. But the influence of Gr thought can certainly not be ignored, and a rationalizing process applied to the angelology would account for the purely Jewish growth of the concepts. (4) is bound up to some degree with the above, and presents the most unpleasant feature of the later Judaism. Sharply counter to prophetic and pre-prophetic teaching, it was modified by the still later Talmudism. Its inconsistency with the teaching of Christ needs no comment. In part, however, it may well have been due to the general "transcendentalizing" tendencies of the intermediate period. See GOD; SALVATION.

It is possible, similarly, to understand the advanced Jewish eschatology as an elaboration and refinement of the genuinely prophetic Day of Jeh concepts, without postulating foreign influence. In particular, a doctrine of immortality was inevitable in Judaism, and the Jewish premises were of a sort that made a resurrection belief necessary. The presence of similar beliefs in Mazdeism may have hastened the process and helped determine the specific form, and for certain details direct borrowing is quite likely (of the twelve periods of world-history in Apoc Abraham 29; Syr Bar 53 ff; 2 Esd 14). But too much stress cannot be laid on details. The extant Pers apocalypses are all very late, and literary (if not religious) influence on them from Christian and Jewish sources seems inevitable (for the Bahman Yast it is certain). Nor could the effect of the Mazdean eschatology have been very thorough. Of its two most cardinal doctrines, the Chinvat Bridge is absent from Judaism, and the molten-metal ordeal is referred to only in the vaguest terms, if at all. Indeed, the very fact that certain doctrines were identified with the "heathen" may well have deterred Jewish acceptance. See PAROUSIA; RESURRECTION.

Similarly, the Messiah, as future king, was fixed in Jewish belief, and His elevation to celestial position was an inevitable step in the general refining process. The Pers Saoshyant doctrine may well have helped, and the appearance of the Messiah "from . . . the sea" in 2 Esd 13 3 certainly recalls the Mazdean appearance from a lake. But Saoshyant is not a celestial figure. He has no existence before his final appearance (or birth) and he comes from earth, not from heaven. The Jewish Son of man—

Messiah—on the other hand, is a purely celestial figure and (even in 2 Esd 13) existed from (or before) creation. The birth of Saoshyant from the seed of Zoroaster and that of the (non-celestial) Messiah from the seed of David have no connection whatever. See MESSIAH; SON OF MAN.

Not much can be made of the parallel in legalism. Nearly every religion has gone through a similar legalistic state. The practical eudemonistic outlook of such works as Prov and Sir (see Wisdom) doubtless have analogies in Mazdeism, and the comfortable union of religion and the good things of the present life among the Persians may well have had an effect on certain of the Jews, esp. as the Persians preserved a good ethical standard. But only a part of Judaism was eudemonistic, and Mazdean and Jewish casuistry are based on entirely distinct principles.

Summarizing, about the most that can be asserted for Mazdean influence is that it left its mark on the angelology and démonology and that it possibly contributed certain eschatological details. Apart from this, it may well have helped determine the development of elements already present in Israel's faith. On the common people (esp. the more superstitious) its influence was considerably greater. But there is nothing in the formal theology of Judaism that can be described as "borrowed" from Mazdean teachings.

NOTE.—There is almost certainly no reference to Mazdean dualism in Isa 45 7.

LITERATURE.—The Avesta is in *SBE*, IV, 23, 31, but the Gathas are best studied in L. H. Mills, *The Gathas of Zarathushtra* (1900); Pahlavi texts in *SBE*, V, 18, 24, 37, 47. The best presentation of Mazdeism is in Saus-saye's *Lehrbuch der Religionsgeschichte*, II, 162–233 (by Ed. Lehmann); of the arts, "Zoroastrianism" in *EB* (Geldner and Cheyne) and *HDB* (J. H. Moulton, excellent); on the relation to Judaism, Stave, *Über den Einfluss des Parsismus auf das Judentum* (1898); Söderblom, *La vie future d'après le Mazdéisme* (An. Mus. Guimet, 1901, needs checking); Böklen, *Die Verwandtschaft der jud.-chr. mit der persischen Eschatologie* (1902, good material but very uncritical); L. H. Mills, *Our Own Religion in Ancient Persia* (1912, theory of parallel development; Mazdeism rather idealized); J. H. Moulton, *Early Zoroastrianism* (1913) and arts. by T. K. Cheyne, *Expos T*, II, 202, 224, 248; and J. H. Moulton, *Expos T*, IX, 352. For details of Clemen, *Religionsgeschichtliche Erklärung des NT* (1909, ET, *Primitive Christianity and Its non-Jewish Sources*); Bousset, *Religion des Judenthums* (ed 2, 1906); *Offenbarung Johannis* (1906); *Hauptprobleme der Gnosis* (1907, indispensable).

BURTON SCOTT EASTON

**ZOROBABEL**, zō-rob'a-bel, zō-rō'ba-bel (Ζοροβὰβελ, *Zorobábel*): In AV; Gr form of "Zerubbabel," thus RV (Mt 1 12.13; Lk 3 27).

**ZORZELLEUS**, zōr-zel'é-us (A, Ζορζιλλεύς, *Zorzelléus*, B [and Swete], Φαηζελδαύτος, *Phazēldautós*, Fritzsche, Βερζιλλαίος, *Berzellaiós*; AV Berzelus; RVm "Phazeldaeus"): The father of Augia, the wife of Jaddus, head of a family that "usurped the office of the priesthood" in the return under Zerubbabel (1 Esd 5 38); "Barzillai" of Ezr 2 61; Neh 7 63. See BARZILLAI.

**ZUAR**, zū'ār, zōō'ar (צֹרָר, *zū'ār*, "little one"; Σωγάρ, *Sogár*): Father of Nethanel (Nu 1 8; 2 5; 7 18.23; 10 15), who was head of the tribe of Issachar.

**ZUPH**, zuf (צֹפֶת, *zūph*, "honeycomb"):

(1) According to 1 S 1 1b; 1 Ch 6 35 (Heb ver 20) = "Zophai" of 1 Ch 6 26 (11), an ancestor of Elkanah and Samuel. But Budde and Wellhausen take it to be an adj., and so read צֹפֶת, *zūphē*, in 1 S 1 1b: "Tohu a Zuphite, an Ephraimite." It should probably be read also in ver 1a: "Now there was a certain man of the Ramathites, a Zuphite of the hill-country of Ephraim," as the Heb construction in the first part of the verse is otherwise unnatural. LXX A has Σούρ, *Sourp*, Luc., Σούφ, *Souph*, in 1 S

1 1b; 1 Ch 6 26 (11), B, Σουφελ, *Souphel*, A, Luc., Σουφί, *Souphí*; 6 35 (20), B A, Σούφ, *Souph*, Luc., Σουφί, *Souphí*, K<sup>e</sup>thíbh, צִיפִּי, *ṣīph*.

(2) LXX B A, Σελφ, *Seíph*, Luc., Σιφά, *Síphá*, "the land of Zuph," a district in Benjamin, near its northern border (1 S 9 5).

DAVID FRANCIS ROBERTS

**ZUR**, zûr (צִיר, *ṣûr*, "rock"):

(1) A prince or chief (Nu 25 15; 31 8) of Midian, father of the woman slain with Zimri by Phinehas. Josh 13 21 describes him as one of the princes of Sihon, but the reference there is regarded as a gloss.

(2) An inhabitant of Gibeon (1 Ch 8 30; 9 36), to be connected probably, according to Curtis, with "Zeror" of 1 S 9 1.

**ZURIEL**, zû'ri-el (צִירִי'ֵל, *ṣûrî'êl*, "my rock is El [God]"): Prince of the house of Merari (Nu 3 35).

The word *ṣûr*, "rock," occurs also in the compound names Elizur (1 5), Zurishaddai (1 6, etc) and Pedahzur (1 10). Gray, *Nu*, 6, says that a Sabaeen name *Ṣûri-*

*'addana* is found in an inscription said to be of the 8th cent. BC, or somewhat earlier (Hommel, *Ancient Heb Tradition*, 320), and בִּרְצִיר, *barṣûr*, in a Zinjirli inscription of the 8th cent. BC (Panammu Inscr., l. 1), and that possibly the OT place-name "Beth-zur" should be added (Josh 15 58; 1 Ch 2 45; 2 Ch 11 7; Neh 3 16).

DAVID FRANCIS ROBERTS

**ZURISHADDAI**, zû-ri-shad'â-i, zû-ri-shad'î (צִירִישַׁדַּי, *ṣûrîshadday*, "my rock is Shadday"): Father of Shelumiel the head of the tribe of Simeon (Nu 1 6; 2 12; 7 36.41; 10 19). See GOD, NAMES OF, II, 8; ZURIEL.

**ZUZIM**, zû'zim (זִזִּים, *zûzîm*; ἔθνη ισχυρά, *éhnē ischurá*, "strong nations." So Jerome in *Quaest. Hebr.*: *gentes fortes*): A people conquered by Chedorlaomer (Gen 14 5). They dwelt in Ham, a region not otherwise known but, from the connection, inferred to be E. of the Jordan. It may also be inferred that they were a race of giants. They were perhaps to be identified with the Zamzumim.





# INDEXES

TO THE

## INTERNATIONAL STANDARD BIBLE ENCYCLOPAEDIA

I. CONTRIBUTORS . . . . .	3163
II. GENERAL INDEX . . . . .	3171
III. SCRIPTURE TEXTS . . . . .	3407
IV. HEBREW AND ARAMAIC WORDS . . . . .	3448
V. GREEK WORDS . . . . .	3502
VI. ILLUSTRATIONS . . . . .	3507
VII. MAPS . . . . .	3528



## INDEX OF CONTRIBUTORS

### NAMES OF AUTHORS AND TITLES OF THEIR PRINCIPAL ARTICLES

- ALEXANDER, REV. ARCHIBALD, B.D., M.A., D.D.,** Clergyman of United Free Church of Scotland; Late Lecturer on Christian Ethics in United Free College, Glasgow.  
Creed (Creeds), Ethics, Logos.
- ALLEN, GEORGE H., PH.D.,** Editor of the "Forum Conche, or Fuero De Cuenca, the Mediaeval Charter and By-laws of the City of Cuenca, Spain"; Grand Rapids, Michigan.  
Army (Roman), Italy, Procurator, Province, Roman Law, Rome, and other articles.
- ANDERSON, REV. FREDERICK LINCOLN, M.A., D.D.,** Professor of New Testament Interpretation, Newton Theological Institution, Newton Centre, Massachusetts.  
Temptation of Christ, Washing of Feet.
- ANGUS, REV. S., M.A., PH.D.,** Professor of New Testament Theology and Church History in St. Andrew's College, University of Sydney, Australia.  
Nabataeans, Nanaea, Nero, Nicanor, Onias, Ptolemy, Roman Empire and Christianity, Tiberius, Tryphon, Vulgate, and other articles.
- ARMSTRONG, WILLIAM P., M.A.,** Professor of New Testament Literature and Exegesis in Princeton Theological Seminary, Princeton, New Jersey.  
Chronology of the New Testament.
- BANKS, EDGAR J., PH.D.,** Formerly Professor of Ancient History in Robert College, Constantinople, Turkey, and Field Director of the Babylonian Expedition of the University of Chicago; Author of various publications; Greenfield, Massachusetts.  
Asia (Roman Province), Assos, Colossae, Diana (Artemis), Halicarnassus, Hierapolis, Pamphylia, Perga, Phrygia, Seven Churches (separate articles), Sherghat (Asshur), Troas, and other articles.
- BAUR, REV. WILLIAM,** Professor of Church History, Eden Seminary, St. Louis, Missouri.  
Balaam, Ishmael, Jubilee Year, Prince, Queen Mother, Reign, Ruler, Sabbatical Year, and other articles.
- BAUSLIN, REV. DAVID H., D.D.,** Dean and Professor of Historical and Practical Theology, Hamma Divinity School, Wittenberg College, Springfield, Ohio.  
Gospel, Preacher (Preaching).
- BAVINCK, HERMAN, D.TH.,** Professor of Dogmatic Theology at the Free University in Amsterdam, The Netherlands.  
Death, Fall (The).
- BEECHER, the late REV. WILLIS JUDSON, M.A., D.D.,** Formerly Professor of Hebrew Language and Literature in Auburn Theological Seminary; Author and Writer for various publications; Auburn, New York.  
Abaddon, Abarim, Abi, Abiathar, Abijah, Achor, Adullam, Ahimelech, Chronicles (Books of), Ecclesiastes, Korah, Korahites, and many other articles.
- BERRY, GEORGE RICKER, D.D., PH.D.,** Professor of Semitic Languages in Colgate University, Hamilton, New York.  
Covenant in the Old Testament, and other articles.
- BETTERIDGE, REV. WALTER R., M.A., D.D.,** Professor of Hebrew and Old Testament Interpretation in the Rochester Theological Seminary, Rochester, New York.  
Creditor, Glory, Gods (Strange), Preparation (The), and other articles.
- BEVAN, REV. LLEWELYN D., LL.B., D.D.,** Principal of Parkin College, Adelaide, Kent Town, Australia.  
Christ (Exaltation of), Christ (Offices of), Intercession, Intercession of Christ, Lamb of God, Prayers of Jesus.
- BISHOP, REV. WILLIAM S., M.A., D.D.,** Formerly Professor of Dogmatic Theology, University of the South at Sewanee, Tennessee; East Orange, New Jersey.  
Baptismal Regeneration (Anglican Standpoint).
- BOYD, REV. JAMES OSCAR, B.D., PH.D.,** Assistant Professor of Oriental and Old Testament Literature in Princeton Theological Seminary, Princeton, New Jersey.  
Abraham, Arabic Language, Isaac, Jacob, Laban, Lot, Rebekah, Sarah, and other articles.
- BRESLICH, ARTHUR LOUIS, B.D., PH.D.,** President of Baldwin-Wallace College and Nast Theological Seminary, Berea, Ohio.  
Amariah, Baasha, Bacchides, Bathsheba, Damage, Desire, Goel, Hallehujah, Ishbosheth, and many shorter articles.
- CALDECOTT, REV. W. SHAW, M.R.A.S.,** Member of the Wesleyan Conferences of Great Britain and South Africa; Bournemouth, England.  
Ahaz, Altar, Amaziah, Athaliah, Jehoash, Jeroboam II, Tabernacle (Historical), Temple (Historical), and other articles.
- CALDER, WILLIAM M., M.A.,** Professor of Greek and Lecturer in Christian Epigraphy in the University of Manchester, Manchester, England.  
Antioch of Pisidia, Asia Minor, Cauda, Crete, Derbe, Iconium, Lycaonia, Lystra, Phoenix, Pisidia.
- CARVER, WILLIAM OWEN, M.A., D.D., TH.D., LL.D.,** Professor of Comparative Religion and Missions, and Associate Professor of New Testament Interpretation, in the Southern Baptist Theological Seminary, Louisville, Kentucky.  
Atonement, Keys (Power of), Propitiation, Truth, and a few shorter articles.
- CAVERNO, REV. CHARLES, M.A., D.D., LL.D.,** Author and retired Clergyman of the Congregational Church; Lombard, Illinois.  
Beauty, Divorce in NT, Family, Polygamy, Purity.

- CHRISTIE, REV. WILLIAM M., Missionary to Jews, Glasgow, and Examiner in Turkish, Glasgow University, Glasgow, Scotland.  
Hamath, Inn, Nazirite, Seleucia, Syria, Zobah, and other articles.
- CLAY, ALBERT T., PH.D., LL.D., Laffan Professor of Assyriology and Babylonian Literature, Yale University, and Curator of the Babylonian Collection, New Haven, Connecticut.  
Ashurbanipal, Babel (Babylon), Babylonia, Esar-haddon, Sargon, Sennacherib, Ur of the Chaldees.
- CLIPPINGER, WALTER GILLAN, B.A., D.D., President of Otterbein University, and Lecturer on Psychology and Education, Westerville, Ohio.  
Blood, Dream (Dreamer), Ecce Homo, Friend (Friendship), Obedience, Rab-mag, Rab-saris, Rabshakeh, and a few other short articles.
- COBERN, REV. CAMDEN M., D.D., PH.D., Professor of English Bible and Philosophy of Religion in Allegheny College, Meadville, Pennsylvania.  
Alexandria, Calf (Golden), Ethiopia, Idolatry, Images, Palestine (Recent Exploration), Tahpanhes, Zerah (The Ethiopian).
- COHON, RABBI SAMUEL S., B.A., Zion Temple, Chicago, Illinois.  
Alliance, Aner, Aran, Ashhur, Ass, Barak, Ben-ammi.
- CONDER, the late COL. CLAUDE REIGNIER, LL.D., M.R.A.S., Cheltenham, England.  
Baal-zephon, Etham, Exodus (The), Goshen, Hittites, Migdol, Palestine, Pithom, Punon, Raamses, Shur, Sinai, Succoth, Wanderings of Israel, Zoan.
- COTTON, REV. JESSE L., D.D., Professor of Old Testament Exegesis in the Presbyterian Theological Seminary, Louisville, Kentucky.  
Hiram, Hobab, and other articles.
- COWAN, REV. HENRY, D.D., Professor of Church History in the University of Aberdeen, Aberdeen, Scotland.  
Literature (Sub-apostolic Christian).
- CRANNELL, REV. PHILIP WENDELL, D.D., President of Kansas City Baptist Theological Seminary, and Professor of Homiletics and Pastoral Theology, Kansas City, Kansas.  
Clean, Cleanse, Defilement, Excommunication, Father, Genealogy, Hallow (Hallowed), Obedience of Christ, Worship, and other articles.
- CRICHTON, REV. JAMES, B.D., M.A., Minister of the United Free Church, Chapelhall, Airdrie, Scotland.  
Gedaliah, Gehazi, Hagar, Jair, Jareb, Jethro, Messiah, Sons of God (OT), and other articles.
- DAU, W. H. T., Professor, Concordia Theological Seminary (Dogmatics, English Bible); Editor "The Theological Quarterly," St. Louis, Missouri.  
Baptism (Lutheran Doctrine), Baptismal Regeneration, Lord's Supper.
- DAVIES, REV. T. WITTON, B.A., D.D., PH.D., Professor of Semitic Languages in the University College at Bangor, North Wales.  
Apocrypha and the Books of, Divination, Magic, Poetry (Hebrew), Witchcraft, and other articles.
- DAVIES, REV. WILLIAM WALTER, M.A., PH.D., Professor of Hebrew, Ohio Wesleyan University, Delaware, Ohio.  
Absalom, Asa, Attitudes, Azariah, Divorce in OT, Nabal, Nahash, and a number of shorter articles.
- DAVIS, REV. JOHN D., D.D., PH.D., LL.D., Professor of Oriental and Old Testament Literature, Princeton Theological Seminary, Princeton, New Jersey.  
Antediluvian Patriarchs, Names (Proper).
- DAY, ALFRED ELY, M.A., M.Sc., Professor of Natural Sciences in the Syrian Protestant College, Beirut, Syria.  
Geology, Natural Features, Zoology, and a large number of articles on related subjects.
- DEMENT, REV. BYRON H., TH.D., D.D., Professor Sunday School Pedagogy, Southern Baptist Theological Seminary, Louisville, Kentucky.  
Repentance, Teaching, and other articles.
- DICKIE, ARCHIBALD CAMPBELL, M.A., F.S.A., A.R.I.B.A., Architect and Assistant Secretary of Palestine Exploration Fund; London, England.  
Arch, Architecture, Building, Cistern, City, House, Ledge, Lodge, Loft.
- DICKIE, REV. JOHN, M.A., Professor of Systematic Theology and New Testament Language and Exegesis in Knox College, Dunedin, New Zealand.  
Christian, Christianity (in Principle and Essence).
- DOOLAN, REV. LEONARD W., B.A., TH.D., Pastor of First Baptist Church, Bowling Green, Kentucky.  
Ornament, Superstition, and other articles.
- DOSKER, REV. HENRY E., M.A., D.D., LL.D., Professor of Church History in the Presbyterian Seminary of Kentucky, Louisville, Kentucky.  
Asmoneans, Between the Testaments, Bishop (General), Cross, Herod, Lord's Supper (Historical), Nazarene, Strange Fire, and other articles.
- DOWNER, BENJAMIN RENO, B.A., Professor of Hebrew and Old Testament, Kansas City Theological Seminary, Kansas City, Kansas.  
Cupbearer, Cushion, Dish, Door, Hangings, Hearth, Home, and other articles.
- DUNELM, HANDLEY. (See Moule, H. C. G.)
- DUNGAN, DAVID ROBERTS, M.A., LL.D., Author; Des Moines, Iowa.  
Evil, Evil One, Evil Thing, Transgression, Trespass, Wickedness.
- EAGER, REV. GEORGE B., M.A., D.D., LL.D., Professor of Biblical Introduction and Pastoral Theology in the Southern Baptist Theological Seminary, Louisville, Kentucky.  
Abolution, Abomination, Abstinence, Alms and Almsgiving, Anointing, Banking, Banquet, Barber, Basin, Basket, Beard, Bed, Bread, Burial, Buying, Cremation, Dress, Embalming, Marriage, Meals, and numerous other articles.
- EASTON, REV. BURTON SCOTT, D.D., PH.D., Professor of New Testament Exegesis, Western Theological Seminary, Chicago, Illinois. Assistant to the Managing Editor in the preparation of this Encyclopaedia.  
American Revised Version, Apostolic Age, Criticism (Graf-Wellhausen Hypothesis), Grace, Hope, Hospitality, Kenosis, Judgment (Last), Parousia, Pauline Theology, Resurrection, Salvation, Saviour, Tongues (Gift of), Tongues (Confusion of), Tools, Trade, Versions (Georgian, Gothic, Slavonic), Wine, Wisdom, Zoroastrianism; numerous briefer articles.

- EDWARDS, REV. DAVID MIALL, M.A.**, Professor of Doctrinal Theology and Philosophy of Religion at the Memorial College (Congregational), Brecon, South Wales.  
Adoration, Affection, Affliction, Ananias, Annas, Drink (Strong), Image, Iniquity, Joy, Mediation (Mediator), Mystery, Ordination, Raca, Savor, Seal, and other articles.
- EISELEN, REV. FREDERICK C., D.D., PH.D.**, Professor of Semitic Languages and Old Testament Exegesis, Garrett Biblical Institute, Evanston, Illinois.  
Habakkuk, Nahum (Book of), Zephaniah (Book of), and other articles.
- ESTES, REV. DAVID FOSTER, M.A., D.D.**, Professor of New Testament Interpretation, Colgate University, Hamilton, New York.  
Covenant (in NT), Priesthood (in NT), and other articles.
- EVANS, REV. ARTHUR WALWYN**, Lately Pastor of First Congregational Church, Springfield, Ohio.  
Daysman, Immanuel, Triumph, and other articles.
- EVANS, MORRIS O., D.D., PH.D.**, Minister of Lawrence Street Congregational Church, Cincinnati, Ohio; Formerly Lecturer on English Bible and Literature at the Independent College, Bangor, North Wales. Managing Editor of this Encyclopaedia.  
Abel, Abolish, Accord, Adam (Books of), All, Anem, Aristobulus, Asiarch, Bank, Beholding, Bloody, Doxology, Gulf, Totemism, and numerous other signed and unsigned articles.
- EVANS, REV. WILLIAM, D.D.**, Lecturer and Associate Dean of the Bible Institute of Los Angeles, California.  
Covetousness, Debt, Extortion, Forerunner, Lying, Poverty, Sons of God (in NT), Wealth, and other articles.
- EWING, REV. WILLIAM, M.A., D.D.**, Minister of Grange United Free Church, Edinburgh, Scotland.  
Bashan, Bethsaida, Capernaum, Decapolis, Edom, Galilee, Gennesaret (Land of), Gilead, Hermon, Judah, Kenites, Midian, Peraea, Pisgah, Samaria, Shephelah, Tiberias, Trachonitis, and a large number of other articles (mainly topographical).
- FAIRBANKS, ARTHUR, PH.D., LITT.D.**, Director of the Museum of Fine Arts, Boston, Massachusetts.  
Greece (Religion in Ancient).
- FARMER, JONES HUGHES, B.A., LL.D.**, Dean in Theology and Professor of New Testament and Patristic Greek, McMaster University, Toronto, Canada.  
Mark (John), Mark (Gospel of).
- FARR, F. K., D.D.**, Professor of New Testament Exegesis and Introduction, Lane Seminary, Cincinnati, Ohio.  
Adam in OT and Apocrypha, Cain, Elijah, and other articles.
- FAULKNER, REV. JOHN ALFRED, M.A., D.D.**, Professor of Historical Theology, Drew Theological Seminary, Madison, New Jersey.  
Justification.
- FINDLAY, REV. ADAM FYFE, M.A.**, Minister of Bristo United Free Church, Edinburgh, Scotland.  
Apocryphal Acts.
- FINDLAY, REV. GEORGE GILLANDERS, M.A., D.D.**, Professor of New Testament Exegesis and Classics at Headingley College, Leeds, England.  
Galatians (Epistle to).
- FLETCHER, LAZARUS, M.A., PH.D., LL.D., F.R.S.**, Director Natural History Departments of the British Museum, London, S.W., England.  
Stones (Precious).
- FORRESTER, REV. ELDEDRED JOHN, B.A., D.D.**, Head of the Department of the Bible and Lecturer in American History, Mercer University, Macon, Georgia.  
Church Government, Esau, Innocence, Jealousy, Reverence, and other articles.
- FORTUNE, PROF. A.W., B.D., M.A.**, Department of New Testament in the College of the Bible, Lexington, Kentucky.  
Alphaeus, Babylon in NT, Children of Israel, Deutero-canonical Books, Eve in NT, and other articles.
- FULTON, A. S., M.A.**, Assistant in the Department of Oriental Printed Books and MSS, British Museum, London.  
Havilah, Kedar, Nebaioth, Ophir, and other articles.
- GEDEN, REV. ALFRED S., M.A., D.D.**, Professor of Old Testament Languages and Literature and of Comparative Religion at the Wesleyan College, Richmond, Surrey, England.  
Joshua, Judges, Ruth, Samuel, and the Books corresponding to those names.
- GENUNG, REV. JOHN FRANKLIN, D.D., L.H.D., PH.D.**, Professor of Literary and Biblical Interpretation, Amherst College, Amherst, Massachusetts.  
Adam in OT, Hezekiah and all succeeding kings of Judah, Job, Job (Book of), Proverb, Proverbs (Book of), and other articles.
- GERBERDING, REV. G. H., M.A., D.D.**, Professor of Practical Theology in the Theological Seminary of the Evangelical Lutheran Church, Maywood, Illinois.  
Catechist (Catechumen), Rehearse, Search, Train, and several brief articles.
- GOODSPEED, EDGAR J., PH.D.**, Associate Professor of Biblical and Patristic Greek, The University of Chicago, Chicago, Illinois.  
Ostraca, Papyrus.
- GRANT, REV. ALEXANDER C., M.A.**, Missionary of the United Free Church of Scotland, Rajputana, India.  
Eber, Elder (in NT), Eli, and a few brief articles.
- GRAY, REV. JAMES M., D.D.**, Minister in the Reformed Episcopal Church, Dean of Moody Bible Institute, Chicago, Illinois.  
Bless, Desired of All Nations, Evangelist, Experience, Peter (Simon), and other articles.
- GUMMEY, REV. HENRY RILEY, JR., M.A., D.D.**, Rector of St. James' Church, Chaplain to the Bishop of Pennsylvania, Downington, Pennsylvania.  
Lord's Supper (Eucharist).
- HARRY, JOSEPH EDWARD, PH.D.**, Professor of Greek, University of Cincinnati, Cincinnati, Ohio.  
Achaia, Almost, Antiochus I-VII, Areopagus, Athens, Corinth, Dionysus (Bacchus), Patmos, Searching the Scriptures, and other articles.
- HAYES, DOREMUS ALMY, PH.D., S.T.D., LL.D.**, Professor of New Testament Interpretation, The Graduate School of Theology, Garrett Biblical Institute, Evanston, Illinois.  
James (Epistle of), Philipians (Epistle to).

- HEIDEL, WILLIAM ARTHUR, M.A., PH.D.**, Professor of Greek Language and Literature, Wesleyan University, Middletown, Connecticut.  
Colony, Government, Greece (Graecia), Hellenism (Hellenist), Mediterranean Sea, Senate (Senator), and other articles.
- HIRSCH, REV. FRANK E., M.A., D.D., LL.D.**, Formerly President Charles City College, Charles City, Iowa; Pastor of Dayton's Bluff (Ger.) Methodist Episcopal Church, St. Paul, Minnesota.  
Courts (Judicial), Crimes, Inheritance, Law (Judicial), Lawyer, Punishments, Scribes, Tribute, and numerous other articles.
- HODGE, REV. CASPAR WISTAR, PH.D.**, Assistant Professor of Systematic Theology, Princeton Theological Seminary, Princeton, New Jersey.  
Faithfulness, Foreknowledge, Imputation, Unchangeableness.
- HOUGH, REV. LYNN HAROLD, B.A., D.D.**, Professor of Historical Theology, Garrett Biblical Institute, Evanston, Illinois.  
Servant of Jehovah (the Lord).
- HOVEY, REV. GEORGE RICE, M.A., D.D.**, President of Virginia Union University, and Professor of Theology, Richmond, Virginia.  
Doorkeeper, Firepan, Flagon, Hadad, and other articles.
- HUNTER, REV. S. F., M.A., B.D.**, Minister of St. Stephen's Presbyterian Church, Ipswich, Queensland, and Lecturer in Old Testament Language and Exegesis in Emmanuel College, Brisbane, within the University of Queensland, Queensland, Australia.  
Ahava, Array, Asunder, Bar-Jesus, Bethabara, Eleazar, Epaphras, Lydia, Philip (Evangelist), and a large number of the shorter articles.
- HUTCHISON, JOHN, M.A., LL.D.**, Rector Emeritus of the High School of Glasgow, Scotland.  
English Versions of the Bible, Apocryphal and Other Early Gospels, and numerous other articles.
- ISAACS, MRS. ELA DAVIS, M.A.**, Cincinnati, Ohio.  
Family Relationships (part), Feasts and Fasts, Fringes, Gershon (Gershonites), Linen, Shamgar, and other articles.
- ISAACS, NATHAN, LL.B., M.A., PH.D.**, Professor of Law, University of Cincinnati and Cincinnati Law School, Cincinnati, Ohio. Assistant Editor of this Encyclopaedia in the Hebrew Language.  
Family Relationships (part), Gallery, Order, Passover, Primogeniture, Rahab, Sceptre, Urim and Thummim, and other articles.
- IVERACH, REV. JAMES, M.A., D.D.**, Principal and Professor of New Testament Language and Literature in the United Free Church College, Aberdeen, Scotland.  
Gospels (The Synoptic), John (The Apostle), John (Gospel of).
- JACOBS, REV. HENRY E., D.D., LL.D.**, Author and Editor of Commentaries, etc; Philadelphia, Pennsylvania.  
Absolution, Andronicus, Appeal, Barnabas, Brethren of the Lord, Chastening (Chastisement), Community of Goods, Confession, Heresy, Temperance, and numerous other articles.
- JOY, ALFRED H., PH.B., M.A., F.R.A.S.**, Professor of Astronomy and Director of the Observatory, Syrian Protestant College, Beirut, Syria.  
Cloud, Dew, Earthquake, Heat, Mirage, Rain, Snow, Weather, and similar articles.
- KAISER, LEWIS**, Professor of Old Testament and Life of Christ in the German Department of Rochester Theological Seminary, Rochester, New York.  
Book of Life, Cruelty, and other articles.
- KAPP, REV. JACOB W., M.A., D.D.**, Pastor of First English Lutheran Church, Cincinnati, Ohio.  
Aeon, Atheism, Benediction, Boy, and other articles.
- KERR, REV. COLIN M., B.Sc., B.D., M.A., PH.D.**, Minister of Church of Scotland at Kettins, Coupar Angus, Scotland; Formerly Professor of Political Philosophy in Scottish Churches College, Calcutta.  
Biographical articles on Andrew, Bartholomew, Caiaphas, Gamaliel, Judas Iscariot, Nicodemus, Thomas, and others.
- KINSELLA, ARTHUR JAMES, M.A.**, Instructor in Greek, University of Cincinnati, Cincinnati, Ohio. Assistant Editor of this Encyclopaedia in the Greek Language.  
Demetrius, Samos, Samothrace, and other articles.
- KNUDSON, REV. ALBERT C., D.D., PH.D.**, Professor of Hebrew and Old Testament Exegesis in Boston University School of Theology, Boston, Massachusetts.  
Judges (Period of).
- KURTZ, REV. DANIEL WEBSTER, M.A., D.D.**, President of McPherson College, McPherson, Kansas.  
Lord's Supper (according to the Church of the Brethren, otherwise called Dunkers), Trine (Triune) Immersion, Washing of Feet.
- KYLE, REV. PROF. MELVIN GROVE, D.D., LL.D.**, Permanent Lecturer on Biblical Archaeology in Xenia Theological Seminary; Archaeological Editor of the Sunday School Times, Philadelphia, Pennsylvania.  
Archaeology and Criticism, Ir-ha-heres, Joseph, Moses, Nile, On (Heliopolis), Pharaoh, Plagues of Egypt, Tell el-Amarna Tablets, and other articles.
- LAMBERT, REV. J. C., M.A., D.D.**, Minister of the United Free Church of Scotland, Braeheads, Fenwick, Scotland.  
Agape, Apostle, Beatitudes, Church, Healing (Gifts of), Holiness, Praise, Prayer, Sacraments, Spiritual Gifts.
- LAW, REV. ROBERT, M.A., D.D.**, Professor of New Testament Literature, Knox College, Toronto, Ontario, Canada.  
Elect Lady, Johannine Theology, John (Epistles of).
- LEES, REV. JOHN A.**, Pastor of St. James' Congregational Church, Hamilton, Scotland.  
Magog, Michael, Michal, Miriam, Naaman, Nadab, Nethinim, and many other articles.
- LEVERTOFF, PAUL, B.D.**, Professor of Old Testament and Talmudic Literature at Institutum Delitzschianum at Leipzig, Germany.  
First-fruits, Judge, Oath, Proselyte, Sanhedrin, Synagogue, Tithe, Vow, Witness.
- LEWIS, CHARLES SMITH, B.A., B.D.**, Professor of New Testament in the Western Theological Seminary, Chicago, Illinois.  
Colossians (Epistle to), Ephesians (Epistle to), Philemon (Epistle to).
- LEWIS, REV. THOMAS, B.D., M.A.**, Principal of Memorial College (Congregational), Brecon, South Wales.  
Blindness (Judicial), Curse, Fasting, Nursing, Ordinance, Prison, and other articles.

- LINDSAY, REV. JAMES, B.Sc., M.A., D.D., F.R.S.L., F.R.S.E., F.G.S., M.R.A.S., Theological and Philosophic Author; Irvine, Scotland.  
Anthropomorphism, Biblical Theology, Creation, Creature, Eternal, Eternity, Predestination.
- LINDSAY, the late REV. THOMAS M., M.A., D.D., LL.D., Principal and Professor of Church History in United Free Church College, Glasgow, Scotland.  
Baptism (Non-Immersionist View), Ministry.
- LITTMAN, ENNO, Ph.D., Professor of Semitic Philology in the University of Göttingen, Germany.  
Ethiopic Language.
- LONGACRE, LINDSAY B., B.D., Ph.D., Professor, Department of Old Testament, Hiff School of Theology, University Park, Colorado.  
Nehushtan.
- LOTZ, WILHELM, D.Th., Ph.D., Professor of Theology in the University of Erlangen, Erlangen, Germany.  
Ark of the Covenant, and other articles.
- LOWNDES, REV. ARTHUR, D.D., S.T.D., LL.D., Secretary of Christian Unity Foundation, New York City, New York.  
Bishop (Anglican View).
- LUERING, HEINRICH LUDWIG EMIL, Ph.D., Professor of Dogmatic Theology and New Testament Greek in the Martin Theological Seminary of the Methodist Episcopal Church, Frankfurt am Main, Germany.  
Contributor of articles on the various parts of the body, and other subjects.
- MACALISTER, ALEXANDER, M.D., M.A., D.Sc., LL.D., F.R.S., F.S.A., Professor of Anatomy in Cambridge University, Cambridge, England.  
Balm, Blindness, Diseases, Healing, Leprosy, Longevity, Medicine, and other articles of a similar character.
- MACK, REV. EDWARD, M.A., D.D., McCormick Professor of Old Testament Interpretation, Union Theological Seminary, Richmond, Virginia. Assistant to the Managing Editor in the preparation of this Encyclopaedia.  
Aaron, Chronology of OT, Covenant (Book of), God (Names of), Presbyter, Semites (Semitic Religion), and other articles.
- MACLAREN, JOHN J., D.C.L., LL.D., Justice of Court of Appeal, Toronto, Ontario, Canada.  
Jesus Christ (Arrest and Trial of).
- MARAIS, JOHANNES I., B.A., D.D., Senior Professor of Theological Seminary of the Dutch Reformed Church at Stellenbosch, Capetown, South Africa.  
Anthropology, Heart, Mind, Psychology, Soul, Spirit.
- MARGOLIS, MAX L., Ph.D., Professor of Biblical Philology, Dropsie College, Philadelphia, Pennsylvania.  
Abner, Caleb, Cherubim, College, Dagon, Dark Sayings, Deborah, and other articles.
- MASTERMAN, ERNEST W. G., M.D., F.R.C.S., F.R.G.S., Medical Superintendent of the English Mission Hospital, Jerusalem, and Honorable Secretary for Jerusalem and Palestine, for the Palestine Exploration Fund; Jerusalem, Syria.  
Botany, Jerusalem, and a large number of articles on botanical, topographical, and other subjects.
- MAUNDER, E. WALTER, F.R.A.S., for forty years Superintendent of the Solar Department of the Royal Observatory, Greenwich, London, England.  
Astrology, Astronomy, and other articles.
- MCALLISTER, REV. J. GRAY, B.A., D.D., Professor of Biblical Introduction, English Bible and Biblical Theology, Presbyterian Theological Seminary of Kentucky, Louisville, Kentucky.  
Hodesh, Hodevah, Hodiah, and other articles.
- M'CAIG, REV. ARCHIBALD, B.A., LL.D., Principal and Theological Tutor, Pastors' College, London, S.E., England.  
Covenant (The New), King (Christ as), Law in the New Testament, and other articles.
- MCCONNELL, FRANCIS J., D.D., Ph.D., LL.D., Bishop of the Methodist Episcopal Church, Denver, Colorado.  
Redeemer (Redemption), Righteousness, Sin.
- MCGLOTHLIN, REV. WILLIAM JOSEPH, M.A., D.D., Ph.D., LL.D., Professor of Church History in Southern Baptist Theological Seminary, Louisville, Kentucky.  
Bondage, Sacrifice (Human), Servant.
- MCPHEETERS, REV. WILLIAM MARCELLUS, D.D., LL.D., Professor of Old Testament Literature and Exegesis, Columbia Theological Seminary (Presbyterian), Columbia, South Carolina.  
Scorn, Simple, Sluggard, Theocracy, Translation.
- MEYER, REV. HENRY H., M.A., D.D., Editor Sunday School Publications for the Methodist Episcopal Church; Secretary Commission on Christian Education of the Federal Council of Churches of Christ in America; Member Gesellschaft für wissenschaftliche Paedagogik (Germany); Cincinnati, Ohio, and New York City, New York.  
Education.
- MILLAR, REV. JAMES, B.D., Minister of Church of Scotland, at New Cumnock, Ayrshire, Scotland.  
Amen, Asaph, Hymn, Instruments of Music, Music, Song, and related articles.
- MILLER, REV. RUSSELL BENJAMIN, M.A., B.D., Ph.D., Professor of Biblical Literature, Ohio Wesleyan University, Delaware, Ohio.  
Communion, John the Baptist, Lord's Prayer, Sermon on the Mount, and other articles.
- MÖLLER, PASTOR WILHELM, Pastor Licentiat der Theologie, Wittenberg, Bz. Halle, Germany.  
Atonement (Day of), Azazel, Exodus (Book of), Ezekiel, Genesis, Leviticus.
- MOOREHEAD, the late REV. WILLIAM G., D.D., LL.D., Professor in the Xenia Theological Seminary, President of the Faculty, Chair of Biblical Theology, Xenia, Ohio.  
Jude, Millennium (Premillennial View), 1 Peter, 2 Peter, Priest, Priesthood, Tongues of Fire, Type.
- MORRO, WILLIAM CHARLES, B.D., M.A., Ph.D., Head of Ministerial Department and Reeves Memorial Chair of Biblical Literature, Butler College, Indianapolis, Indiana.  
Body (Spiritual), Forgiveness, Lawgiver, Way.
- MOSIMAN, SAMUEL K., M.A., B.D., Ph.D., President Bluffton College, Instructor in Old Testament Languages and Interpretation, Bluffton, Ohio.  
Ahab, Ahaziah, Elah, Jehoram (Joram), Jehoshaphat, Jeroboam I, Omri, Rehoboam, Zimri.

- MOULE, RT. REV. HANDLEY CARR GLYN, D.D.**, Bishop of Durham, England.  
Elect, Election, Faith, Perseverance, Romans (Epistle to), Sinlessness, Unbelief, Unbeliever, Witness of the Spirit, World (General).
- MULLINS, E. Y., D.D., LL.D.**, President Southern Baptist Theological Seminary, Louisville, Kentucky. Assistant Editor of this Encyclopaedia.  
Advocate, Baptism of the Holy Spirit, Comforter, Holy Spirit, Paraclete.
- NICOL, RT. REV. THOMAS, D.D.**, Professor of Divinity and Biblical Criticism in the University of Aberdeen; Moderator of the Grand Assembly of the Church of Scotland; Aberdeen, Scotland.  
Armor (Arms), Army, Ben-hadad, Captivity, Chemosh, Dispersion (The), Latin Version (The Old), Ships and Boats, Syriac Versions, War (Warfare), and other articles.
- NUELSEN, JOHN L., D.D., LL.D.**, Bishop of Methodist Episcopal Church, Kilchberg bei Zürich, Switzerland. Assistant Editor of this Encyclopaedia.  
Conversion, Regeneration.
- OKO, ADOLPH S.**, Librarian, Hebrew Union College, Cincinnati, Ohio.  
Commentaries (Hebrew).
- O'RELLI, the late CONRAD VON, PH.D.**, Doctor of Theology, Professor in Ordinary of Old Testament and History of Religion at the University of Basel, Basel, Switzerland.  
Israel (History of the People), Israel (Religion of), Jeremiah, Lamentations (Book of), Micah, Prophecy (Prophets).
- ORR, the late REV. JAMES, M.A., D.D.**, Professor of Apologetics and Theology at Theological College of United Free Church, Glasgow, Scotland.  
Editor-in-Chief of this Encyclopaedia.  
Apostles' Creed, Apostolic Fathers, Baptismal Regeneration, Bible (The), Caesar, Candlestick (Golden), Christianity (Historical and Doctrinal), Christs (False), Commentaries, Concordance, Criticism of the Bible, Endor (Witch of), Eschatology of the OT, Father (God The), God (Image of), Hands (Imposition of), Hell, Immortality, Infinite (Infinite), Jesus Christ, Knowledge, Man of Sin, Moses (Song of), Prison (Spirits in), Punishment (Everlasting), Revelation of John, Serpent Worship, Seventy Weeks, Synagogue (The Great), Tabernacle (A. Structure and History), Temple (A. Structure and History), Unquenchable Fire, World (Cosmological), and hundreds of short articles.
- PATCH, JAMES A., B.S.**, Professor of Chemistry in the Syrian Protestant College, Beirut, Syria.  
Agriculture, Brick, Brimstone, Colors, Crafts, Dyeing, Embroidery, Fishing, Fuller, Gardener, Metallurgy, Oil, Pottery, Shepherd, Weaving, and other articles.
- PETRIE, WILLIAM MATTHEW FLINDERS, D.C.L., PH.D., LITT.D., LL.D., F.R.S., F.B.A., Hon. F.S.A. (Scot.), Hon. A.R.I.B.A., M.R.I.A., M. Amer. Phil. Soc.**, Edwards Professor of Egyptology, University College, London, England.  
Egypt, Memphis.
- PINCHES, THEOPHILUS GOLDRIDGE, LL.D., M.R.A.S.**, Lecturer in Assyrian at University College, London, and Liverpool Institute of Archaeology; late of the Department of Egyptian and Assyrian Antiquities, British Museum, London, England.  
Africa, Amraphel, Arioch, Babel (Babylon), Cyrus, Elam (Elamites), Hammurabi, Nineveh, Table of Nations, and several other articles.
- POLLARD, REV. EDWARD BAGBY, M.A., D.D., PH.D.**, Professor of Homiletics, Crozer Theological Seminary, Chester, Pennsylvania.  
Familiar, Maid, Rabbi, Self-surrender, Tribulation, Usury, and other articles.
- PORTER, H., PH.D.**, Professor Emeritus of History and Psychology in the Syrian Protestant College, Beirut, Syria.  
Easter, Money, Parthians, Phoenicia, Scythians, Sidon, Syrians, Tammuz, Time, Tyre, Weights and Measures, and other articles.
- PRATT, REV. DWIGHT MALLORY, M.A., D.D.**, Minister of the Walnut Hills Congregational Church, Cincinnati, Ohio.  
Agony, Apostasy, Beloved, Bishop (Congregational View), Catholic Epistles, Enchantment, Epistle, Spiritual, Spirituality, Woman, and other articles.
- PRESCOTT, W. W., M.A.**, Editor of the Protestant Magazine, Washington, District of Columbia.  
Sabbath (from the Standpoint of Seventh-day Adventists).
- PRESS, S. D.**, Professor of Practical Theology and Systematic Theology, Eden Theological Seminary, St. Louis, Missouri.  
King (Kingdom), Rachel, Stephanas, Stephen.
- RAFFETY, WILLIAM EDWARD, B.D., M.A., PH.D.**, Professor of Religious Pedagogy and Sociology, Kansas City Baptist Theological Seminary, Kansas City, Kansas.  
Crown, Ish-sechel, Lust, Market, Merchandise, Service, Slavery, Traffic, Treasure (Treasury), Wages, Wares, and other articles.
- RALL, REV. HARRIS FRANKLIN, D.D., PH.D.**, Professor of Systematic Theology, Garrett Biblical Institute, Evanston, Illinois.  
Guilt, Guiltless, Guilty, Justice, Sanctification.
- RAMSAY, SIR WILLIAM M., D.D., D.C.L., LL.D., LITT.D.**, Formerly Professor of Humanity, University of Aberdeen; Edinburgh, Scotland.  
Galatia.
- REES, REV. THOMAS, M.A.**, Principal and Professor of Theology, Independent College (Congregational), Bangor, North Wales.  
Adoption, Authority (in Religion), Beelzebub, Blasphemy, Commandment (New), Doctrine, Dogma, Epicureans, God, Hebrews (Epistle to), Philosophy, Stoics, and other articles.
- REEVE, REV. JAMES JOSIAH, B.A., B.D., TH.D.**, Formerly Professor of Hebrew and Cognate Languages and Old Testament Theology in the Southwestern Baptist Theological Seminary at Fort Worth, Texas; Chicago, Illinois.  
Elisha, Gods, Gog, Goliath, Life, Priest (High), Sacrifice in OT, Tree of Life, and other articles.
- RICHARDSON, ERNEST CUSHING, PH.D.**, Librarian of Princeton University, Princeton, New Jersey.  
Alphabet, Book, Dictionaries, Ink, Ink-horn, Libraries, Manuscripts, Print (Printing), Roll (Scroll), Tablet, Writing, and other articles.
- RIGGS, REV. JAMES S., D.D.**, Professor of New Testament Theology and Literature, Auburn Theological Seminary, Auburn, New York.  
Canon of the New Testament.
- ROBERTS, REV. DAVID FRANCIS, B.A., B.D.**, Minister of Maenofferen Calvinistic Methodist Church, Blaenau Ffestiniog, North Wales.  
Boaz, Javan, Jerahmeel, Jeshurun, Jesse, Jezebel, Joab, Joash, Melchizedek, Nathan, Old Prophet, Queen of Sheba, Zimri, and numerous short articles.



- ROBERTSON, REV. A. T., M.A., D.D., LL.D., Professor of New Testament Interpretation, Southern Baptist Theological Seminary, Louisville, Kentucky.  
Acts of the Apostles, Baptism (The Baptist Interpretation), Language of the New Testament (Greek), Latin, Luke (The Evangelist), Luke (Gospel of), Paul.
- ROBERTSON, REV. JAMES, M.A., D.D., LL.D., Emeritus Professor of Hebrew and Semitic Languages at the University of Glasgow, Scotland.  
Amos, Hosea, Joel.
- ROBINSON, REV. GEORGE L., M.A., D.D., PH.D., LL.D., Professor of Biblical Literature and English Bible in the McCormick Theological Seminary, Chicago, Illinois.  
Canon of Old Testament, Deuteronomy, Haggai, Isaiah, Malachi, Samson.
- ROGERS, ROBERT WILLIAM, PH.D., LITT.D., LL.D., Professor of Hebrew and Old Testament Exegesis, Drew Theological Seminary, Madison, New Jersey.  
Babylonia and Assyria (Religion of).
- RULE, REV. U. Z., now retired from benefice in diocese of Winchester; ordained in 1864 in diocese of Newfoundland; Forest Road, Worthing, England.  
Law in the Old Testament.
- RUTHERFURD, JOHN, B.D., M.A., Minister of Moorpark United Free Church, Renfrew, Scotland.  
Caesar's Household, Faithful Sayings, Gnosticism, Laodiceans (Epistle to), Onesiphorus, Pastoral Epistles, Persecution, Praetorian Guard, Rudiments, Timothy, Titus, Tychicus, and other articles.
- SAMPEY, REV. JOHN RICHARD, B.A., D.D., LL.D., Professor of Old Testament Interpretation in the Southern Baptist Theological Seminary, Louisville, Kentucky.  
Ephod, Jonah, Jonah (Book of), Obadiah, Obadiah (Book of), Psalms (Book of), Sabbath, Song of Songs, Ten Commandments, and other articles.
- SAYCE, REV. ARCHIBALD HENRY, D.D., LITT.D., LL.D., Professor of Assyriology in University of Oxford, Oxford, England.  
Amorites, Anakim, Asherah, Ashtoreth, Assyria, Atargatis, Baal, Canaan (Canaanites), Girsu, Hivite, Moabite Stone, Nineveh (Library of), Perizzite, and other articles.
- SCHENK, REV. CHARLES E., D.D., Superintendent, Cincinnati District, Methodist Episcopal Church, Cincinnati, Ohio.  
Earnest, Gideon, Jael, Moon, Poetry (New Testament), Prophecies (False), Sisera, and other articles.
- SCHODDE, REV. GEORGE HENRY, D.D., PH.D., Professor in College and Theological Departments of Capital University, Columbus, Ohio.  
Allegory, Interpretation, Matthew, Matthew (Gospel of), Parable.
- SHAW, REV. R. DYKES, M.A., D.D., Formerly Minister of Hope Park United Free Church, Edinburgh; General Secretary to the Presbyterian Alliance; Edinburgh, Scotland.  
1 and 2 Corinthians.
- SITTERLY, CHARLES FREMONT, S.T.D., PH.D., Professor of Biblical Literature in Drew Theological Seminary, Madison, New Jersey.  
Text and Manuscripts of the New Testament.
- SMITH, W. TAYLOR, B.A., Private Student and Graduate of University of Manchester; Sevenoaks, England.  
Acrostic, Agrapha, Games, Logia, Number.
- STALKER, REV. JAMES, M.A., D.D., Professor of Church History, United Free Church College, Aberdeen, Scotland.  
Accountability, Conscience, Ethics of Jesus, Kingdom of God (of Heaven), Son of God, Son of Man.
- STEARNS, WALLACE NELSON, B.D., PH.D., Professor of Biblical History and Literature, Fargo College, Fargo, North Dakota.  
Child (Children), Elder (in the OT), Gad ("Fortune"), Kings (Books of), and other articles.
- STEELE, the late REV. DANIEL, D.D., Author and Educator; First President of Syracuse University; Milton, Massachusetts.  
Sanctification (Wesleyan Doctrine).
- STRACK, HERMANN L., D.D., PH.D., Professor of Old Testament Exegesis and Semitic Languages, Berlin University, Berlin, Germany.  
Talmud.
- STRATTON-PORTER, GENE, Author and Illustrator; Special Writer on Birds and Nature; Rome City, Indiana.  
The Birds of the Bible (under the various titles), Cage, Feathers, Fowler, Gin, Nest, Snare, Trap, Wings.
- STUART, REV. CHARLES M., M.A., D.D., LITT.D., LL.D., President, Garrett Biblical Institute, Evanston, Illinois.  
Shame, Sign, Tempt, Temptation, Transfiguration, Vision.
- SWEET, LOTIS MATTHEWS, M.A., S.T.D., Professor of Christian Theology and Apologetics, Bible Teachers' Training School, New York City, New York.  
Accommodation, Demon (Demonic), Genealogy of Jesus Christ, Mary, Quotations (New Testament), Satan, Tax (Taxing), Virgin-birth (of Jesus Christ), and other articles.
- THACKERAY, HENRY ST. JOHN, M.A., Civil Servant, and Author of various works; Bucks, England.  
Septuagint.
- THOMAS, REV. WILLIAM HENRY GRIFFITH, D.D., Professor of Old Testament Literature and Exegesis, Wycliffe College, Toronto, Canada.  
Adam in the New Testament, Ascension, Resurrection of Jesus Christ.
- THOMSON, the late REV. CHARLES H., M.A., United Free Church of Scotland Missionary to the Jews at Constantinople; Glasgow, Scotland.  
Antioch in Syria, Berothah, Damascus, and other articles.
- THOMSON, REV. J. E. H., M.A., D.D., Retired Missionary; Edinburgh, Scotland.  
Alexander the Great, Antichrist, Apocalyptic Literature, Aramaic Language, Ebionism, Essenes, Pentateuch (Samaritan), Pharisees, Raphael, Sadducees, Targum.
- TILLET, REV. WILBUR F., M.A., D.D., S.T.D., LL.D., Dean of the Theological Faculty and Professor of Systematic Theology in Vanderbilt University, Nashville, Tennessee.  
Providence.

- TISDALL, REV. W. ST. CLAIR, D.D.**, Formerly C.M.S. Missionary in India and Persia; Vicar of St. George the Martyr's, Deal, Kent, England. Armenia, Armenian (Aryan) Religion, Comparative Religion, Coptic Versions, Medes, Persia, Persian Religion (Ancient), and other articles.
- TOD, MARCUS NIEBUHR, M.A.**, Fellow and Assistant Tutor of Oriol College, Oxford, and University Lecturer in Greek Epigraphy, Oxford, England. Cyprus, Macedonia, Philippi, Tarsus, Thessalonica, and other articles.
- TREVER, REV. GEORGE HENRY, M.A., D.D., PH.D.**, Professor of New Testament Exegesis and Christian Doctrine, Gammon Theological Seminary, Atlanta, Georgia.  
Burden, Care, Citizenship, Cornelius, Day-spring, Lazarus, and other articles.
- UMBACH, the late REV. S. L., D.D.**, noted for his extensive travels in Europe, Asia and Africa; Naperville, Illinois.  
Shallum (1st article), and several short articles.
- UNGNAD, ARTHUR, PH.D.**, Professor of Oriental Philology at the University of Jena, Jena, Germany.  
Hammurabi (Code of).
- URQUHART, REV. JOHN**, Author; Editor of the "Bible Investigator and Inquirer"; Member of the Victoria Institute; Melbourne, Australia.  
Esther, Esther (Book of), Hadassah, Haman, Mordecai, Vashti, Zeresh.
- VAN PELT, REV. J. R., B.A., S.T.B., PH.D.**, Professor of Philosophy and Biblical Literature, Cornell College, Mt. Vernon, Iowa.  
Bath Kol, Chemarim, Discrepancies (Biblical), Doom, Duke, and other articles.
- VOS, REV. GEERHARDUS, D.D., PH.D.**, Charles T. Haley Professor of Biblical Theology, Princeton Theological Seminary, Princeton, New Jersey.  
Eschatology of New Testament, Hades, Heavens (New) and Earth (New), Lake of Fire, Omnipotence, Omnipresence, Omniscience, and other articles.
- WACE, VERY REV. HENRY, D.D.**, Dean of Canterbury, Canterbury, England.  
Miracle.
- WALKER, REV. ROLLIN HOUGH, PH.D.**, Jeffers Professor of the English Bible, Ohio Wesleyan University, Delaware, Ohio.  
1 and 2 Thessalonians.
- WALKER, REV. W. L., D.D.**, Congregational Minister (Retired); Glasgow, Scotland.  
Compassion, Creature (Living), Duty, End, Fear, Fervent, Figure, Fool (Folly), Gesture, Good (Chief), Humility, Mercy, Name, Person (Personality), Reason, Substance, Will (Volition), and a large number of short articles.
- WALLACE, REV. HENRY**, Pastor of Parkhead Congregational Church, Glasgow, Scotland.  
Hilkiah, Ichabod, Mephibosheth, Merab, Merari, Meshch, Phinehas, and other biographical articles.
- WARFIELD, REV. BENJAMIN BRECKINRIDGE, D.D., LL.D., LITT.D.**, Professor of Didactic and Polemic Theology, Theological Seminary of the Presbyterian Church in the U.S.A. at Princeton, New Jersey.  
Godhead, Inspiration, Person of Christ, Revelation, Trinity.
- WEBB, REV. ROBERT ALEXANDER, B.A., D.D., LL.D.**, Professor of Apologetics and Systematic Theology, Presbyterian Theological Seminary of Kentucky, Louisville, Kentucky.  
Man (Natural), Man (New).
- WEIR, REV. THOMAS HUNTER, B.D., M.A., M.R.A.S.**, Lecturer on Arabic in the University of Glasgow, Glasgow, Scotland.  
Arabia, Arabic Versions, Ethiopic Versions, Israel (Kingdom of), Judah (Kingdom of), Languages of the Old Testament, Saul, Solomon, Text of the Old Testament, and other articles.
- WENLEY, ROBERT MARK, M.A., PH.D., D.Sc., LL.D., LITT.D., D.C.L.** Professor of Philosophy in the University of Michigan, Ann Arbor, Michigan.  
Josephus (Flavius), Philo (Judaean).
- WHITE, REV. GEORGE EDWARD, M.A., D.D.**, Missionary of the American Board; President of Anatolia College, Marsovan, Turkey.  
Asia Minor (Archaeology of), Cappadocia, Cilicia, Pontus.
- WHITELAW, REV. THOMAS, M.A., D.D.**, Minister of King Street United Free Church, Kilmarnock, Scotland.  
Ithamar, Numbers (Book of), Tabernacle (in Criticism), Temple (in Criticism), Zadok.
- WIENER, HAROLD M., M.A., LL.B.**, Barrister at Law; London, England.  
Agrarian Laws, Altar (A. Critical), Hexateuch, Levitical Cities, Pentateuch, Priests and Levites, Sanctuary, Stranger and Sojourner (in OT), and other articles.
- WILLIAMS, CHARLES B., M.A., B.D., PH.D.**, Professor in the Chair of New Testament Greek and New Testament Theology, Southwestern Baptist Theological Seminary, Fort Worth, Texas.  
Sacrifice in the New Testament, Satan (Synagogue of), Tradition, Uncleaness, and other articles.
- WILSON, REV. J. MACARTNEY, B.D., M.A.**, Minister of United Presbyterian Church, New Glasgow, Nova Scotia, Canada.  
Angels, Apocryphal Epistles, Birthright, Chief Seats, Pilate (Pontius).
- WILSON, REV. ROBERT DICK, M.A., PH.D.**, Professor of Semitic Philology and Old Testament Introduction, Princeton, New Jersey.  
Arsaces, Daniel, Daniel (Book of), Ezra, Nebuchadnezzar, Nehemiah, Tirshatha, Zerubabel, and other articles.
- WOLF, RABBI HORACE J.**, Bachelor of Hebrew Literature, M.A., Associate Rabbi of Berith Kodish Congregation, Rochester, New York.  
Afternoon, Day and Night, Samgar-nebo, Segub, Shaphan, Sheshach, Tubal, Tubalcain, and numerous brief articles.
- WRIGHT, REV. GEORGE FREDERICK, M.A., D.D., LL.D., F.G.S.A.**, Professor Emeritus in Oberlin College, Oberlin, Ohio.  
Antediluvians, Arabah, Cities of the Plain, Dead Sea, Deluge of Noah, Eden, Euphrates, Jordan, Jordan Valley, Paradise, Tigris, and other articles.
- ZENOS, REV. ANDREW C., D.D., LL.D.**, Professor of Historical Theology, McCormick Theological Seminary, Chicago, Illinois.  
Evolution.

## GENERAL INDEX

- A . . . . . 1<sup>a</sup>; 90<sup>a</sup> (Richardson); 105<sup>a</sup>  
(Richardson)
- Aalar (Allar) . . . . . 1<sup>a</sup>; 97<sup>b</sup>
- Aaron . . . . . 1<sup>a</sup> (Mack)  
Elder . . . . . 1<sup>b</sup>  
Family . . . . . 1<sup>a</sup>  
cf Moses . . . . . 2083<sup>b</sup> (Kyle)  
Moses' assistant . . . . . 1<sup>a</sup>  
Priest . . . . . 1<sup>b</sup>  
Priestly succession . . . . . 2<sup>a</sup>  
Rebellion . . . . . 1<sup>b</sup>  
Rod of . . . . . 2<sup>a</sup> (Mack)  
cf Priest . . . . . 2439<sup>a</sup> (Moorehead)
- Aaronites . . . . . 2<sup>a</sup> (Beecher)
- Ab (father) . . . . . 2<sup>b</sup> (Beecher)  
cf Abba . . . . . 4<sup>a</sup> (Harry)  
cf Abi . . . . . 6<sup>b</sup> (Beecher)
- Ab (month) . . . . . 2<sup>b</sup>
- Abacuc . . . . . 2<sup>b</sup>
- Abaddon (Heb) . . . . . 2<sup>b</sup> (Beecher)  
cf Apollyon . . . . . 201<sup>b</sup> (Sweet)
- Abadias . . . . . 3<sup>a</sup>
- Abagarus . . . . . 3<sup>a</sup>  
cf Abgar . . . . . 6<sup>b</sup> (Breslich)
- Abagtha . . . . . 3<sup>a</sup>
- Abana  
cf Amana . . . . . 113<sup>a</sup> (C. H. Thomson)  
cf Pharpar . . . . . 2365<sup>b</sup>
- Abanah . . . . . 3<sup>a</sup>  
cf Abilene . . . . . 11<sup>a</sup> (C. H. Thomson)  
cf Amana . . . . . 113<sup>a</sup> (C. H. Thomson)
- Abarim . . . . . 3<sup>b</sup> (Beecher)
- Abase . . . . . 3<sup>b</sup> (Hirsch)
- Abate . . . . . 4<sup>a</sup>
- Abba . . . . . 4<sup>a</sup> (Harry)  
cf Ab (father) . . . . . 2<sup>b</sup> (Beecher)
- Abda . . . . . 4<sup>a</sup>
- Abdeel . . . . . 4<sup>a</sup>
- Abdi . . . . . 4<sup>a</sup> (Beecher)
- Abdias . . . . . 4<sup>a</sup>  
cf Obadiah . . . . . 2173<sup>a</sup> (Sampey)
- Abdiel . . . . . 4<sup>a</sup>
- Abdon (person) . . . . . 4<sup>a</sup> (Beecher)  
cf Samson . . . . . 2675<sup>a</sup> (Robinson)
- Abdon (place) . . . . . 4<sup>b</sup> (Beecher)
- Abednego . . . . . 4<sup>b</sup> (R. D. Wilson)  
cf Shadrach . . . . . 2746<sup>a</sup> (R. D. Wilson)
- Abel (person) . . . . . 5<sup>a</sup> (M. O. Evans)  
And Cain . . . . . 539<sup>a</sup> (Farr)  
NT references . . . . . 5<sup>a</sup>  
cf Sacrifice . . . . . 2638<sup>a</sup> (Reeve)  
Shepherd and worship-  
per . . . . . 5<sup>a</sup>
- Abel (place) . . . . . 5<sup>b</sup>
- Abel-beth-maacah . . . . . 5<sup>b</sup> (Beecher)  
cf Abel-maim . . . . . 6<sup>a</sup>
- Abel-cheramim . . . . . 5<sup>b</sup>  
cf Plain . . . . . 2406<sup>b</sup> (Day)
- Abel-maim . . . . . 6<sup>a</sup>  
cf Abel-beth-maacah . . . . . 5<sup>b</sup> (Beecher)
- Abel-meholah . . . . . 6<sup>a</sup> (Beecher)  
cf Meholathite . . . . . 2028<sup>a</sup>
- Abel-mizraim . . . . . 6<sup>a</sup> (Beecher)
- Abel-shittim . . . . . 6<sup>a</sup> (Beecher)
- Abez . . . . . 6<sup>b</sup>  
cf Ebez . . . . . 890<sup>b</sup>
- Abgar . . . . . 6<sup>b</sup> (Breslich)  
cf Abagarus . . . . . 3<sup>a</sup>
- Abgarus  
cf Abagarus . . . . . 3<sup>a</sup>
- Abhor . . . . . 6<sup>b</sup> (Breslich)  
cf Abomination . . . . . 15<sup>b</sup> (Eager)
- Abi (father) . . . . . 6<sup>b</sup> (Beecher)  
cf Ab (father) . . . . . 2<sup>b</sup> (Beecher)  
cf Abijah . . . . . 10<sup>a</sup> (Beecher)  
Compounds of . . . . . 7<sup>a</sup>
- Abi (name) . . . . . 6<sup>b</sup>
- Abia, Abiah . . . . . 7<sup>b</sup>  
cf Abijah . . . . . 10<sup>a</sup> (Beecher)
- Abi-albon . . . . . 7<sup>b</sup> (Beecher)  
cf Abiel . . . . . 9<sup>a</sup>
- Abiasaph . . . . . 7<sup>b</sup> (Beecher)
- Abiathar . . . . . 7<sup>b</sup> (Beecher); 85<sup>a</sup> (Beecher)  
cf Ahimelech . . . . . 85<sup>a</sup> (Beecher)  
cf Ahitub . . . . . 86<sup>b</sup> (Beecher)  
Biblical record of . . . . . 7<sup>b</sup>  
Critical opinion . . . . . 8<sup>b</sup>  
cf David . . . . . 790<sup>b</sup> (Weir)  
cf Ephod . . . . . 962<sup>a</sup> (Sampey)  
cf Priest, High . . . . . 2441<sup>b</sup> (Reeve)  
cf Zadok . . . . . 3129<sup>b</sup> (Whitelaw)
- Abib . . . . . 9<sup>a</sup> (Beecher); 541<sup>b</sup> (Por-  
ter)  
cf Calendar . . . . . 541<sup>b</sup> (Porter)
- Abida . . . . . 9<sup>a</sup>
- Abidah . . . . . 9<sup>a</sup>
- Abidan . . . . . 9<sup>a</sup>
- Abide . . . . . 9<sup>a</sup> (Pratt)
- Abiel . . . . . 9<sup>a</sup>  
cf Abi-albon . . . . . 7<sup>b</sup>
- Abiezer . . . . . 9<sup>a</sup> (Beecher)  
cf Iezer . . . . . 1448<sup>b</sup>  
cf Jeezer . . . . . 1574<sup>a</sup>
- Abiezrite  
cf Abiezer . . . . . 9<sup>a</sup> (Beecher)

- Abigail, Abigal . . . . . 9<sup>b</sup> (Mack)  
   cf Abraham . . . . . 18<sup>a</sup> (Boyd)  
   cf Jesse . . . . . 1623<sup>a</sup> (Roberts)  
   cf Zeruiah . . . . . 3148<sup>a</sup> (Roberts)  
 Abihail . . . . . 10<sup>a</sup> (Mack)  
 Abihu . . . . . 10<sup>a</sup>  
 Abihud . . . . . 10<sup>a</sup>  
   cf Abiud . . . . . 13<sup>b</sup>  
 Abijah . . . . . 10<sup>a</sup> (Beecher)  
   cf Abi . . . . . 6<sup>b</sup>  
   cf Ahi . . . . . 83<sup>b</sup>  
   cf Ahiah . . . . . 83<sup>b</sup>  
   cf Ahitub . . . . . 86<sup>b</sup> (Beecher)  
   Problems in connection  
     with . . . . . 10<sup>b</sup>  
   Record of reign . . . . . 10<sup>a</sup>  
   cf Zacharias . . . . . 3129<sup>b</sup> (Easton)  
 Abijam (Abijah) . . . . . 10<sup>b</sup> (Beecher)  
 Abila  
   cf Abilene . . . . . 11<sup>a</sup> (C. H. Thomson)  
 Abilene . . . . . 11<sup>a</sup> (C. H. Thomson)  
   cf Abanah . . . . . 3<sup>a</sup> (C. H. Thomson)  
   cf Lysanias . . . . . 1943<sup>b</sup> (Kerr)  
 Ability . . . . . 11<sup>a</sup>  
 Abimael . . . . . 11<sup>a</sup> (Beecher)  
 Abimelech . . . . . 11<sup>b</sup> (Mack); 36<sup>b</sup>  
   cf Achish . . . . . 36<sup>a</sup> (Mack)  
   cf Gaal . . . . . 1150<sup>a</sup>  
 Abinadab . . . . . 12<sup>a</sup> (Beecher)  
   And the Ark . . . . . 243<sup>a</sup> (Lotz)  
   cf Ben-abinadab . . . . . 434<sup>a</sup>  
 Abinoam . . . . . 12<sup>b</sup>  
 Abiram . . . . . 12<sup>b</sup> (Beecher)  
   cf Korah . . . . . 1816<sup>b</sup> (Beecher)  
 Abiron . . . . . 12<sup>b</sup>  
   cf Abiram . . . . . 12<sup>b</sup> (Beecher)  
 Abisei . . . . . 13<sup>b</sup>  
 Abishag . . . . . 12<sup>b</sup> (Beecher)  
   cf Abraham . . . . . 18<sup>a</sup> (Boyd)  
 Abishai . . . . . 13<sup>a</sup> (Mack); 15<sup>a</sup> (Margolis)  
   cf Jesse . . . . . 1623<sup>a</sup> (Roberts)  
 Abishalom . . . . . 13<sup>a</sup>  
   cf Absalom . . . . . 23<sup>a</sup> (W. W. Davies)  
 Abishua . . . . . 13<sup>a</sup>  
 Abishur . . . . . 13<sup>b</sup>  
 Abissei . . . . . 13<sup>b</sup>  
 Abisue . . . . . 13<sup>b</sup>  
 Abisum  
   cf Abisue . . . . . 13<sup>b</sup>  
 Abital . . . . . 13<sup>b</sup>  
 Abitub . . . . . 13<sup>b</sup>  
   cf Ahitub . . . . . 86<sup>b</sup> (Beecher)  
 Abiud . . . . . 13<sup>b</sup>  
   cf Abihud . . . . . 10<sup>a</sup>  
   cf Genealogy . . . . . 1183<sup>b</sup> (Crannell)  
 Abject . . . . . 13<sup>b</sup>  
 Able . . . . . 13<sup>b</sup>  
 Ablution . . . . . 13<sup>b</sup> (Eager)  
   Attitude of Jesus . . . . . 14<sup>b</sup>  
   Biblical references . . . . . 13<sup>b</sup>  
   Ceremonies of . . . . . 14<sup>a</sup>  
 Abner . . . . . 14<sup>b</sup> (Margolis); 13<sup>a</sup>  
   cf Joab . . . . . 1677<sup>b</sup> (Roberts)  
 Abode  
   cf Abide . . . . . 9<sup>a</sup> (Pratt)  
 Abolish . . . . . 15<sup>a</sup> (M. O. Evans)  
 Abomination . . . . . 15<sup>b</sup> (Eager)  
   Abhor . . . . . 6<sup>b</sup> (Breslich)  
   Birds of . . . . . 16<sup>a</sup> (Stratton-Porter)  
     cf Abomination . . . . . 15<sup>b</sup> (Eager)  
     cf Birds, Unclean . . . . . 477<sup>b</sup> (Reeve)  
   Clean and unclean animals . . . . . 16<sup>a</sup>  
   Of desolation . . . . . 16<sup>b</sup> (Hirsch)  
     Antiochus Epiphanes . . . . . 17<sup>a</sup>; 159<sup>b</sup> (Harry)  
     Historical background . . . . . 17<sup>a</sup>  
     cf Jupiter . . . . . 1781<sup>a</sup> (Easton)  
     Suppression of worship . . . . . 17<sup>b</sup>  
     Term in Daniel . . . . . 16<sup>b</sup>  
   cf Food . . . . . 1121<sup>b</sup> (Eager)  
   Ideas of . . . . . 15<sup>b</sup>  
   Unclean foods . . . . . 16<sup>a</sup>  
   Words used . . . . . 15<sup>b</sup>  
 Abound, Abundance,  
   Abundant . . . . . 17<sup>b</sup> (Van Pelt)  
 About . . . . . 18<sup>a</sup>  
 Abraham . . . . . 13<sup>a</sup> (Boyd)  
   cf Abigail . . . . . 9<sup>b</sup> (Mack)  
   cf Abishag . . . . . 12<sup>b</sup> (Beecher)  
   Book of  
     cf Apoc Literature . . . . . 161<sup>b</sup> (J. E. H. Thomson)  
   Career . . . . . 18<sup>b</sup>  
   Character . . . . . 20<sup>a</sup>  
   Conditions of life . . . . . 19<sup>a</sup>  
   Economic and social conditions . . . . . 19<sup>b</sup>  
   Faith of . . . . . 1088<sup>a</sup>  
   Family of, in Genesis . . . . . 1207<sup>a</sup> (Möller)  
   Interpretation of story . . . . . 21<sup>b</sup>  
   cf Isaac . . . . . 1493<sup>a</sup> (Boyd)  
   cf Jacob . . . . . 1549<sup>a</sup> (Boyd)  
   Kindred . . . . . 18<sup>b</sup>  
   cf Lot . . . . . 1930<sup>a</sup> (Boyd)  
   cf Machpelah . . . . . 1959<sup>b</sup> (Masterman)  
   cf Mamre . . . . . 1973<sup>a</sup> (Masterman)  
   Myth and saga . . . . . 22<sup>a</sup>  
   Name . . . . . 18<sup>a</sup>  
   NT references . . . . . 21<sup>a</sup>  
   cf Palestine . . . . . 2210<sup>a</sup> (Conder)  
   Period of wandering . . . . . 18<sup>b</sup>  
   Religion and morality . . . . . 20<sup>a</sup>  
   Religious significance of . . . . . 21<sup>a</sup>  
   Residences . . . . . 19<sup>a</sup>  
   Sacrifice of . . . . . 19<sup>a</sup>  
   cf Sarah . . . . . 2691<sup>a</sup> (Boyd)  
   cf Semites, Semitic Religion . . . . . 2717<sup>a</sup> (Mack)  
   cf Table of Nations . . . . . 2899<sup>b</sup> (Pinches)

- Abraham's Bosom . . . . . 22<sup>b</sup> (Orr)  
 cf Eschatology of OT . 972<sup>a</sup> (Orr)  
 cf Gulf . . . . . 1310<sup>b</sup> (M. O. Evans)  
 cf Hades . . . . . 1315<sup>a</sup> (Vos)  
 cf Paradise . . . . . 2246<sup>a</sup> (Wright)  
 cf Sheol . . . . . 2761<sup>a</sup> (Orr)
- Abram  
 cf Abraham . . . . . 18<sup>a</sup> (Boyd)
- Abrech . . . . . 22<sup>b</sup> (Mack)
- Abroad . . . . . 22<sup>b</sup> (Jacobs)  
 Scattered  
 cf Dispersion . . . . . 855<sup>a</sup> (Nicol)
- Abronah . . . . . 23<sup>a</sup>
- Absalom . . . . . 23<sup>a</sup> (W. W. Davies); 794<sup>b</sup>  
 (Weir)  
 David's flight . . . . . 23<sup>b</sup>  
 Death and tomb . . . . . 23<sup>b</sup>  
 Exile . . . . . 23<sup>a</sup>  
 cf Joab . . . . . 1678<sup>a</sup> (Roberts)  
 Rebellion . . . . . 23<sup>a</sup>  
 cf Tamar . . . . . 2907<sup>b</sup> (Orr)  
 Tomb of . . . . . 24<sup>a</sup>  
 cf Jerusalem . . . . . 1612<sup>a</sup> (Masterman)
- Absalom (Apoc) . . . . . 24<sup>a</sup>
- Absalon (Absalom,  
 Apoc) . . . . . 24<sup>a</sup>
- Absolution . . . . . 24<sup>a</sup> (Jacobs)  
 cf Forgiveness . . . . . 1132<sup>b</sup> (Morro)  
 cf Keys, Power of . . . . . 1794<sup>a</sup> (Carver)  
 cf Remission . . . . . 2557<sup>b</sup> (Jacobs)
- Abstinence . . . . . 24<sup>b</sup> (Eager)  
 Ascetics . . . . . 25<sup>a</sup>  
 Degrees of . . . . . 25<sup>a</sup>  
 cf Essenes . . . . . 997<sup>b</sup> (J. E. H. Thomson)  
 cf Fast, Fasting . . . . . 1099<sup>a</sup> (T. Lewis)  
 cf Food . . . . . 1121<sup>b</sup> (Eager)  
 Jesus' attitude . . . . . 25<sup>b</sup>  
 Practice and teaching  
 of apostles . . . . . 26<sup>b</sup>  
 Public fasts . . . . . 24<sup>b</sup>  
 Talmud . . . . . 25<sup>b</sup>  
 cf Temperance . . . . . 2929<sup>b</sup> (Jacobs)
- Abubus . . . . . 26<sup>b</sup>
- Abundance, Abundant . . 17<sup>b</sup> (Van Pelt)
- Abuse . . . . . 26<sup>b</sup>
- Abyss . . . . . 26<sup>b</sup> (T. Lewis); 314<sup>b</sup>  
 cf Astronomy . . . . . 300<sup>b</sup> (Maunder)  
 cf Pit . . . . . 2401<sup>b</sup> (T. Lewis)
- Abyssinia  
 cf Ethiopia . . . . . 1031<sup>a</sup> (Cobern)
- Acacia . . . . . 27<sup>a</sup> (Masterman)  
 cf Mulberry Trees . . . . . 2093<sup>b</sup> (Masterman)
- Acatan  
 cf Akatan . . . . . 88<sup>b</sup>
- Accaba . . . . . 27<sup>b</sup>  
 cf Hagabah . . . . . 1316<sup>a</sup>
- Accad, Accadians  
 cf Agabus . . . . . 69<sup>a</sup> (Edwards)  
 cf Babylonia . . . . . 365<sup>a</sup> (Clay)
- Accaron . . . . . 27<sup>b</sup>  
 cf Ekron . . . . . 916<sup>a</sup> (Porter)
- Accept, Acceptable . . . . 27<sup>b</sup> (Pratt)  
 cf Respect of Persons 2561<sup>b</sup> (Easton)
- Acceptance . . . . . 27<sup>b</sup> (Pratt)
- Access . . . . . 27<sup>b</sup> (Pratt)
- Accho (Acco) . . . . . 28<sup>a</sup> (Porter)
- Acco . . . . . 28<sup>a</sup> (Porter)  
 Biblical references . . . . 28<sup>a</sup>  
 History . . . . . 28<sup>a</sup>  
 Ptolemais . . . . . 28<sup>a</sup>; 2499<sup>a</sup>  
 cf Sea, The Great . . . . . 2707<sup>b</sup> (Ewing)
- Accommodation . . . . . 28<sup>b</sup> (Sweet)
- Allegory . . . . . 29<sup>b</sup>; 97<sup>b</sup> (Schodde)  
 cf Babylonia . . . . . 358<sup>b</sup> (Clay)  
 Christ's method . . . . . 33<sup>a</sup>  
 cf Demon . . . . . 827<sup>b</sup> (Sweet)  
 Interpretation . . . . . 29<sup>a</sup>; 1489<sup>a</sup> (Schodde)  
 Kenosis . . . . . 1792<sup>a</sup> (Easton)  
 Prophecy and fulfil-  
 ment . . . . . 30<sup>a</sup>  
 Quotations in NT . . . . . 30<sup>a</sup>; 2516<sup>a</sup> (Sweet)  
 Revelation . . . . . 29<sup>a</sup>; 2573<sup>b</sup> (Warfield)
- Accomplish . . . . . 33<sup>a</sup>
- Accord, According, Ac-  
 cordingly . . . . . 33<sup>b</sup> (M. O. Evans)  
 cf Deed . . . . . 817<sup>a</sup> (Edwards)
- Accos . . . . . 33<sup>b</sup>
- Account, Accountability 33<sup>b</sup> (Stalker)
- Accoz . . . . . 34<sup>b</sup>; 89<sup>a</sup>
- Accursed . . . . . 34<sup>b</sup> (T. Lewis)  
 cf Anathema . . . . . 130<sup>a</sup> (T. Lewis)
- Accuser . . . . . 35<sup>a</sup> (W. W. Davies)
- Acelanda (Akeldama) . . . 89<sup>a</sup> (Masterman)
- Achaia . . . . . 35<sup>a</sup> (Harry)
- Achaicus . . . . . 35<sup>b</sup>  
 cf Corinth . . . . . 710<sup>a</sup> (Harry)
- Achan . . . . . 35<sup>b</sup> (Beecher)  
 cf Achor . . . . . 37<sup>a</sup> (Beecher)  
 cf Ochran . . . . . 2178<sup>a</sup>
- Achar (Achan) . . . . . 35<sup>b</sup> (Beecher)
- Achaz . . . . . 36<sup>a</sup>
- Achbor . . . . . 36<sup>a</sup> (Beecher)
- Achiacharus . . . . . 36<sup>a</sup>  
 cf Nasbas . . . . . 2120<sup>a</sup> (Angus)
- Achias . . . . . 36<sup>a</sup>
- Achim . . . . . 36<sup>a</sup>
- Achior . . . . . 36<sup>a</sup>
- Achipha . . . . . 36<sup>a</sup>  
 cf Hakupha . . . . . 1321<sup>b</sup>
- Achish . . . . . 36<sup>a</sup> (Mack); 11<sup>b</sup>
- Achitob . . . . . 36<sup>b</sup>  
 cf Ahitub . . . . . 86<sup>b</sup> (Beecher)
- Achmetha . . . . . 36<sup>b</sup> (Tisdall)
- Acho (Acco) . . . . . 28<sup>a</sup> (Porter)
- Achor . . . . . 37<sup>a</sup> (Beecher); 35<sup>b</sup>  
 (Beecher)
- Achsa . . . . . 37<sup>a</sup>
- Achsah . . . . . 37<sup>a</sup> (Beecher)
- Achshaph . . . . . 37<sup>a</sup>
- Achzib . . . . . 37<sup>b</sup> (Mack; Porter)
- Acipha (Achipha) . . . . . 36<sup>a</sup>
- Acitho, Acithoh . . . . . 37<sup>b</sup>; 86<sup>b</sup> (Beecher)
- Acknowledge . . . . . 37<sup>b</sup>

- Acquaint, Acquaintance 37<sup>b</sup> (Jacobs)  
 Acra . . . . . 38<sup>a</sup>  
   of Jerusalem . . . . . 1595<sup>b</sup> (Masterman)  
 Acrabattene (Akrabattine) . . . . . 89<sup>a</sup>  
 Acrabbim . . . . . 38<sup>a</sup>  
   of Akrabim . . . . . 89<sup>a</sup>  
 Acre (Acco) . . . . . 28<sup>a</sup> (Porter)  
 Acre . . . . . 38<sup>a</sup> (Beecher)  
 Acrostic . . . . . 38<sup>a</sup> (Smith)  
   of Alphabet . . . . . 105<sup>a</sup> (Richardson)  
 Acts, Apocryphal . . . . . 183<sup>b</sup> (A. F. Findlay)  
   Acts of Andrew . . . . . 192<sup>b</sup>  
   Acts of John . . . . . 191<sup>b</sup>  
   Acts of Paul . . . . . 188<sup>b</sup>  
   Acts of Peter . . . . . 190<sup>a</sup>  
   Acts of Thomas . . . . . 193<sup>b</sup>  
   Authorship . . . . . 187<sup>a</sup>  
   Ecclesiastical testimony . . . . . 186<sup>a</sup>  
   Extra-canonical . . . . . 184<sup>a</sup>  
   False and heretical . . . . . 184<sup>a</sup>  
   General characteristics 184<sup>a</sup>  
   Influence . . . . . 187<sup>b</sup>  
   of Literature, Sub-apos. 1896<sup>b</sup> (Cowan)  
   Meaning of apocryphal . . . . . 183<sup>b</sup>  
   Origin . . . . . 185<sup>a</sup>  
   of Publius . . . . . 2501<sup>a</sup> (Kerr)  
   Relationship of different acts . . . . . 187<sup>a</sup>  
   \*Secret . . . . . 184<sup>a</sup>  
   Sources . . . . . 185<sup>b</sup>  
   of Thaddaeus . . . . . 2964<sup>a</sup> (Kerr)  
   Value . . . . . 187<sup>a</sup>  
     As history . . . . . 187<sup>a</sup>  
     As records of early Christianity . . . . . 187<sup>a</sup>  
 Acts of the Apostles . . . . . 39<sup>a</sup> (A. T. Robertson); 466<sup>a</sup> (Orr)  
   Analysis . . . . . 46<sup>b</sup>  
   Author . . . . . 41<sup>a</sup>  
   Canonicity . . . . . 41<sup>b</sup>  
   Chronology . . . . . 44<sup>a</sup>  
   Date . . . . . 41<sup>b</sup>  
   Historical worth . . . . . 44<sup>b</sup>  
   of Luke, Evangelist . . . . . 1935<sup>b</sup> (A. T. Robertson)  
   of Luke, Gospel of . . . . . 1937<sup>a</sup> (A. T. Robertson)  
   of Mediation, Mediator 2022<sup>b</sup> (Edwards)  
   Paul . . . . . 41<sup>a</sup>; 42<sup>a</sup>; 42<sup>b</sup>; 43<sup>a</sup>; 46<sup>a</sup>  
   Purpose . . . . . 45<sup>b</sup>  
   Relation to Ep. of Paul 43<sup>b</sup>  
   Relation to Josephus . . . . . 41<sup>b</sup>  
   Sources . . . . . 42<sup>a</sup>  
   Speeches . . . . . 42<sup>b</sup>  
   Text . . . . . 39<sup>a</sup>  
   Title . . . . . 39<sup>a</sup>  
   Unity . . . . . 40<sup>a</sup>  
   "We" sections . . . . . 40<sup>a</sup>; 41<sup>a</sup>  
 Acts of Pilate  
   of Apocryphal Gospels 195<sup>a</sup> (Hutchison)  
 Acts of Solomon . . . . . 48<sup>a</sup>
- Acua (Acud) . . . . . 48<sup>a</sup>  
 Acub . . . . . 48<sup>a</sup>  
 Acud . . . . . 48<sup>a</sup>; 89<sup>a</sup>  
 Adab . . . . . 364<sup>b</sup> (Clay)  
 Adad (Hadad) . . . . . 1313<sup>b</sup> (Hovey)  
 Adadah . . . . . 48<sup>a</sup>  
 Adadrimmon . . . . . 48<sup>b</sup>  
   of Hadadrimmon . . . . . 1314<sup>a</sup> (Ewing)  
 Adah . . . . . 48<sup>b</sup> (Beecher)  
 Adaiah . . . . . 48<sup>b</sup> (Beecher)  
 Adalia . . . . . 48<sup>b</sup>  
 Adam, Books of . . . . . 54<sup>a</sup> (M. O. Evans); 177<sup>a</sup> (J. E. H. Thomson); 178<sup>b</sup> (T. W. Davies)  
 Adam, City of . . . . . 54<sup>a</sup> (Wright)  
 Adam and the Fall . . . . . 1092<sup>a</sup> (Bavinck)  
   Family . . . . . 1095<sup>a</sup>  
   of Woman . . . . . 3100<sup>a</sup> (Pratt)  
 Adam in NT . . . . . 52<sup>b</sup> (Thomas)  
   of Adam in OT and Apoc . . . . . 48<sup>b</sup> (Farr)  
   of Adam in OT (Evolutionary Interpretation) . . . . . 49<sup>b</sup> (Genung)  
 Adam in OT and Apoc . . . . . 48<sup>b</sup> (Farr)  
   of Fall . . . . . 1092<sup>a</sup> (Bavinck)  
   of Sin . . . . . 2798<sup>b</sup> (McConnell)  
   Usual interpretation . . . . . 48<sup>b</sup> (Farr); 53<sup>b</sup> (Thomas); 139<sup>a</sup> (Davis)  
 Adam in OT (Evolutionary Interpretation) . . . . . 49<sup>b</sup> (Genung)  
   of Eve in OT . . . . . 1040<sup>a</sup> (Genung)  
   of Fall . . . . . 1092<sup>a</sup> (Bavinck)  
 Adamah . . . . . 54<sup>a</sup>  
 Adamant . . . . . 54<sup>a</sup> (Day)  
   of Stones, Precious . . . . . 2856<sup>a</sup> (Fletcher)  
 Adami . . . . . 54<sup>a</sup>  
 Adami-nekeb . . . . . 54<sup>b</sup> (Beecher)  
 Adan (Addan) . . . . . 54<sup>b</sup>  
 Adapa, Story of . . . . . 373<sup>b</sup> (Rogers)  
 Adar . . . . . 54<sup>b</sup>  
   of Addar . . . . . 55<sup>a</sup>  
 Adarsa (Adasa) . . . . . 54<sup>b</sup>  
 Adasa . . . . . 54<sup>b</sup>  
 Adbeel . . . . . 54<sup>b</sup>  
 Add . . . . . 54<sup>b</sup> (M. O. Evans)  
   of Impart . . . . . 1461<sup>b</sup>  
   of Supply . . . . . 2871<sup>b</sup> (Easton)  
 Addan . . . . . 54<sup>b</sup>  
 Addar . . . . . 55<sup>a</sup>  
   of Ard . . . . . 238<sup>b</sup>  
 Adder . . . . . 55<sup>a</sup> (Day)  
   of Serpent . . . . . 2736<sup>a</sup> (Day)  
 Addi . . . . . 55<sup>a</sup>  
 Addict . . . . . 55<sup>a</sup>  
 Addo . . . . . 55<sup>a</sup>  
   of Iddo . . . . . 1447<sup>b</sup> (Crannell)  
 Addon (Addan) . . . . . 54<sup>b</sup>  
 Addus . . . . . 55<sup>a</sup>  
 Ader . . . . . 55<sup>b</sup>  
   of Eder . . . . . 899<sup>a</sup> (Masterman)

- Adiabene . . . . . 55<sup>b</sup> (Beecher)  
 Adida . . . . . 55<sup>b</sup>  
   cf Hadid . . . . . 1315<sup>b</sup>  
 Adiel . . . . . 55<sup>b</sup> (S. F. Hunter)  
 Adin . . . . . 55<sup>b</sup> (Beecher)  
   cf Adinu . . . . . 56<sup>a</sup>  
 Adina . . . . . 55<sup>b</sup>  
 Adino . . . . . 56<sup>a</sup> (Beecher)  
 Adinu . . . . . 56<sup>a</sup>  
   cf Adin . . . . . 55<sup>b</sup> (Beecher)  
 Adinus (Iadinus) . . . . . 1446<sup>a</sup>  
 Adithaim . . . . . 56<sup>a</sup>  
 Adjuration . . . . . 56<sup>a</sup> (Pratt)  
   cf Oath . . . . . 2172<sup>b</sup> (Levertoff)  
 Adlai . . . . . 56<sup>a</sup>  
 Admah . . . . . 56<sup>b</sup> (Wright)  
   cf Shinab . . . . . 2771<sup>a</sup> (Wolf)  
   cf Vale of Sid'im . . . . . 2784<sup>a</sup> (Wright)  
 Admatha . . . . . 56<sup>b</sup>  
 Admin (Arni) . . . . . 258<sup>b</sup>  
 Administer, Administra-  
   tion . . . . . 56<sup>b</sup> (Pratt)  
 Admiration . . . . . 56<sup>b</sup> (Pratt)  
 Adna . . . . . 56<sup>b</sup>  
 Adnah . . . . . 57<sup>a</sup>  
 Ado . . . . . 57<sup>a</sup> (Eager)  
 Adonai . . . . . 57<sup>a</sup>  
   cf God, Names of . . . . . 1264<sup>b</sup> (Mack)  
 Adonibezek . . . . . 57<sup>a</sup>  
 Adonijah . . . . . 57<sup>a</sup> (Beecher)  
 Adonikam . . . . . 58<sup>a</sup>  
 Adoniram . . . . . 58<sup>a</sup> (Beecher)  
   cf Hadoram (Joram) . . . . . 1316<sup>a</sup> (Hovey)  
 Adonis . . . . . 58<sup>a</sup>  
   cf Tammuz . . . . . 2908<sup>a</sup> (Porter)  
 Adonizedek . . . . . 58<sup>a</sup> (Mack)  
   cf Jerusalem . . . . . 1613<sup>b</sup> (Masterman)  
 Adoption . . . . . 58<sup>a</sup> (Rees)  
   cf Children of God . . . . . 608<sup>a</sup> (Rees)  
   Christian experience . . . . . 59<sup>a</sup>  
   As God's act . . . . . 59<sup>b</sup>  
   Legal idea . . . . . 58<sup>b</sup>  
   Paul's doctrine . . . . . 58<sup>b</sup>  
 Ador, Adora . . . . . 60<sup>a</sup>  
 Adoraim . . . . . 60<sup>a</sup>  
 Adoram (Hadoram) . . . . . 1316<sup>a</sup> (Hovey)  
   cf Jeroboam I . . . . . 1593<sup>a</sup> (Mosiman)  
 Adoration . . . . . 60<sup>a</sup> (Edwards)  
   cf Attitudes . . . . . 330<sup>b</sup> (W. W. Davies)  
   cf Kiss . . . . . 1813<sup>b</sup> (W. L. Walker)  
 Adorn . . . . . 61<sup>b</sup> (Kapp)  
   cf Dress . . . . . 875<sup>b</sup> (Eager)  
 Adra (Arad) . . . . . 221<sup>b</sup> (Beecher)  
 Adrammelech, Anamme-  
   lech . . . . . 61<sup>b</sup> (Beecher); 129<sup>a</sup>  
   cf Gods . . . . . 1270<sup>b</sup> (Reeve)  
   cf Sharezer . . . . . 2750<sup>a</sup> (Eiselen)  
 Adramyttium . . . . . 62<sup>a</sup> (Banks)  
 Adria . . . . . 62<sup>a</sup> (Allen)  
 Adriel . . . . . 62<sup>b</sup>  
 Aduel . . . . . 62<sup>b</sup>
- Adullam . . . . . 32<sup>b</sup> (Beecher)  
   cf Hereth . . . . . 1377<sup>a</sup> (Masterman)  
   cf Odollam . . . . . 2178<sup>b</sup>  
 Adullamite . . . . . 63<sup>a</sup>  
 Adultery . . . . . 63<sup>a</sup> (Margolis)  
   cf Crimes . . . . . 745<sup>b</sup> (Hirsch)  
   cf Divorce in NT and  
     OT . . . . . 865<sup>a</sup> (Caverno); 863<sup>b</sup> (W.  
       W. Davies)  
   cf Family . . . . . 1094<sup>b</sup> (Caverno)  
   cf Jealousy . . . . . 1572<sup>b</sup> (Forrester)  
 Adummim . . . . . 64<sup>a</sup> (Beecher)  
 Advantage . . . . . 64<sup>b</sup>  
 Advent  
   cf Millennium . . . . . 2052<sup>b</sup> (Moorehead)  
   cf Parousia . . . . . 2249<sup>a</sup> (Easton)  
   cf Person of Christ . . . . . 2343<sup>a</sup> (Warfield)  
   Prophecy of . . . . . 832<sup>b</sup> (Gray)  
 Advent, Second  
   In Didache . . . . . 1899<sup>b</sup> (Cowan)  
 Adventure . . . . . 64<sup>a</sup>  
 Adversary . . . . . 64<sup>b</sup> (T. Lewis)  
 Adversity . . . . . 64<sup>b</sup> (Pratt)  
 Advertise . . . . . 64<sup>b</sup>  
 Advice, Advise, Advise-  
   ment . . . . . 65<sup>a</sup> (Breslich)  
 Advocate . . . . . 65<sup>a</sup> (Mullins)  
   cf Comforter . . . . . 679<sup>a</sup> (Mullins)  
   cf Holy Spirit . . . . . 1406<sup>a</sup> (Mullins)  
   cf Paraclete . . . . . 2245<sup>a</sup> (Mullins)  
 Aduytum . . . . . 65<sup>a</sup>  
   cf Temple . . . . . 2930<sup>a</sup> (Caldecott; Orr)  
 Aedias . . . . . 65<sup>a</sup>  
 Aelia  
   cf Jerusalem . . . . . 1595<sup>b</sup> (Masterman)  
 Aeneas . . . . . 65<sup>a</sup>; 240<sup>a</sup> (Dosker)  
 Aenon . . . . . 65<sup>b</sup> (Ewing)  
   cf Salim . . . . . 2663<sup>a</sup> (Ewing)  
 Aeon . . . . . 65<sup>b</sup> (Kapp)  
   cf Gnosticism . . . . . 1240<sup>a</sup> (Rutherford)  
 Acsora . . . . . 65<sup>b</sup>  
 Affect, Affection . . . . . 65<sup>b</sup> (Edwards)  
   cf Passion . . . . . 2255<sup>b</sup> (Easton)  
 Affinity . . . . . 66<sup>a</sup> (W. W. Davies)  
   cf Family . . . . . 1094<sup>b</sup> (Caverno)  
   cf Marriage . . . . . 1996<sup>b</sup> (Eager)  
 Affirm, Affirmatives . . . . . 66<sup>a</sup> (Hirsch)  
 Affliction . . . . . 66<sup>a</sup> (Edwards)  
   Endurance of . . . . . 67<sup>b</sup>  
   Meaning and purpose . . . . . 66<sup>b</sup>  
   cf Providence . . . . . 2476<sup>b</sup> (Tillett)  
   Source . . . . . 66<sup>a</sup>  
 Affright . . . . . 68<sup>a</sup>  
 Afoot . . . . . 68<sup>a</sup>  
 Afore . . . . . 68<sup>a</sup>  
 Afresh . . . . . 68<sup>a</sup> (Edwards)  
 Africa . . . . . 68<sup>a</sup> (Pinches)  
   cf Cush . . . . . 767<sup>b</sup> (Pinches)  
   cf Ethiopia . . . . . 1031<sup>a</sup> (Cobern)  
   cf Mizraim . . . . . 2069<sup>a</sup> (Kyle)  
 After, Afterwards . . . . . 68<sup>b</sup> (Jacobs)

- Afternoon . . . . . 68<sup>b</sup> (Wolf)  
   of Day . . . . . 797<sup>b</sup> (Gerberding)  
 Agaba . . . . . 69<sup>a</sup>  
   of Accaba . . . . . 27<sup>b</sup>  
 Agabus . . . . . 69<sup>a</sup> (Edwards)  
 Agade . . . . . 69<sup>a</sup>  
   of Accad . . . . . 365<sup>a</sup> (Clay)  
 Agag . . . . . 69<sup>a</sup> (Mack)  
 Agagite . . . . . 69<sup>a</sup> (Wolf)  
   of Purim . . . . . 2507<sup>a</sup> (Mack)  
 Again . . . . . 69<sup>b</sup>  
   Born again  
     of Regeneration . . . . . 2546<sup>b</sup> (Nuelsen)  
 Against . . . . . 69<sup>b</sup> (Jacobs)  
 Agape . . . . . 69<sup>b</sup> (Lambert)  
   of Lord's Supper . . . . . 1923<sup>b</sup> (Kurtz)  
 Agar . . . . . 70<sup>b</sup>  
 Agarenes . . . . . 70<sup>b</sup>  
   of Hagrites . . . . . 1319<sup>a</sup> (Mack)  
 Agate  
   of Stones, Precious . . . . . 2856<sup>a</sup> (Fletcher)  
 Age . . . . . 70<sup>a</sup> (W. L. Walker)  
   of Everlasting . . . . . 1041<sup>a</sup> (Orr)  
 Age, Old Age . . . . . 71<sup>a</sup> (W. L. Walker)  
   Regard for . . . . . 71<sup>a</sup>  
 Agee . . . . . 71<sup>b</sup>  
 Ages, Rock of . . . . . 71<sup>b</sup>  
 Aggaba . . . . . 71<sup>b</sup>; 27<sup>b</sup>  
 Aggaeus . . . . . 71<sup>b</sup>  
 Agia (Apoc) . . . . . 71<sup>b</sup>  
   of Hattil . . . . . 1343<sup>b</sup>  
 Agone . . . . . 71<sup>b</sup>  
 Agony . . . . . 71<sup>b</sup> (Pratt)  
   Mental . . . . . 72<sup>a</sup>  
   Physical . . . . . 72<sup>a</sup>  
   Spiritual . . . . . 72<sup>a</sup>  
 Agrapha . . . . . 72<sup>a</sup> (Smith)  
   of Logia . . . . . 1910<sup>a</sup> (Smith)  
 Agrarian Laws . . . . . 74<sup>a</sup> (Wiener)  
   of Levitical Cities . . . . . 1869<sup>a</sup> (Wiener)  
   of Priests and Levites 2446<sup>b</sup> (Wiener)  
 Agree . . . . . 75<sup>b</sup> (Kapp)  
 Agriculture . . . . . 75<sup>b</sup> (Patch)  
   of Blasting . . . . . 486<sup>a</sup> (Patch)  
   of Furrow . . . . . 1150<sup>a</sup> (Patch)  
   of Gleaning . . . . . 1234<sup>b</sup> (Patch)  
   of Harrow . . . . . 1341<sup>a</sup> (Patch)  
   of Harvest . . . . . 1341<sup>b</sup> (Patch)  
   of Husbandry . . . . . 1442<sup>b</sup> (Patch)  
   of Irrigation . . . . . 1492<sup>b</sup> (Patch)  
   of Mill . . . . . 2052<sup>a</sup> (Patch)  
   of Reaping . . . . . 2534<sup>a</sup> (Patch)  
   of Seed . . . . . 2712<sup>b</sup> (Easton)  
   of Sheaf . . . . . 2752<sup>a</sup> (Patch)  
   of Sheep . . . . . 2756<sup>b</sup> (Day)  
   of Stubble . . . . . 2867<sup>b</sup>  
   of Threshing . . . . . 2975<sup>b</sup> (Patch)  
   of Tools . . . . . 2993<sup>b</sup> (Easton)  
   of Vine . . . . . 3049<sup>b</sup> (Masterman)  
   of Weaving . . . . . 3077<sup>a</sup> (Patch)  
   of Wheel . . . . . 3082<sup>b</sup> (Easton)
- Agriculture—*continued*  
   of Winepress . . . . . 3086<sup>a</sup> (Easton)  
 Agrippa (Herod) . . . . . 1378<sup>b</sup> (Dosker)  
 Agrippina  
   of Nero . . . . . 2135<sup>a</sup> (Angus)  
 Ague . . . . . 78<sup>a</sup> (Macalister)  
   of Fever . . . . . 1107<sup>b</sup> (Macalister)  
 Agur . . . . . 78<sup>a</sup> (Genung)  
   of Jakeh . . . . . 1559<sup>b</sup> (Crichton)  
   of Proverbs, Book of . . . . . 2471<sup>b</sup> (Genung)  
 Ah  
   of Ahi . . . . . 83<sup>b</sup>  
 Ah, Aha . . . . . 78<sup>a</sup> (Mack); 1311<sup>a</sup>  
 Ahab . . . . . 78<sup>b</sup> (Mosiman)  
   And archaeology . . . . . 80<sup>a</sup>; 294<sup>a</sup>  
   And Benhadad . . . . . 779<sup>b</sup> (C. H. Thomson)  
   Building operations . . . . . 79<sup>b</sup>  
   Death of . . . . . 80<sup>a</sup>  
   And Elijah . . . . . 79<sup>b</sup>  
   Foreign policy . . . . . 73<sup>b</sup>  
   of Israel, History of the  
     People . . . . . 1521<sup>a</sup> (Orelli)  
   of Jehoshaphat . . . . . 1582<sup>a</sup> (Mosiman)  
   of Jezebel . . . . . 1675<sup>b</sup> (Roberts)  
   Military career . . . . . 79<sup>b</sup>  
   Moabite Stone . . . . . 2071<sup>b</sup> (Sayce)  
   Murder of Naboth . . . . . 79<sup>a</sup>  
   Reign of . . . . . 73<sup>b</sup>  
   Religious policy . . . . . 79<sup>a</sup>  
 Ahab and Zedekiah . . . . . 80<sup>a</sup> (S. F. Hunter)  
 Aharah . . . . . 80<sup>b</sup>; 86<sup>a</sup> (Beecher)  
 Aharhel . . . . . 80<sup>b</sup>  
 Ahasai (Ahzai) . . . . . 87<sup>b</sup>  
 Ahasbai . . . . . 80<sup>b</sup>  
 Ahasuerus . . . . . 80<sup>b</sup> (R. D. Wilson)  
   of Xerxes . . . . . 3126<sup>a</sup> (Easton)  
 Ahava . . . . . 81<sup>a</sup> (S. F. Hunter)  
 Ahaz . . . . . 81<sup>a</sup> (Caldecott)  
   of Dial of Ahaz . . . . . 841<sup>a</sup> (Maunder)  
   Fall of Damascus . . . . . 82<sup>a</sup>  
   Isaiah's tablet . . . . . 81<sup>b</sup>  
 Ahaziah . . . . . 82<sup>b</sup> (Mosiman)  
   of Chronology of OT . . . . . 635<sup>a</sup> (Mack)  
   Eighth king of Israel . . . . . 82<sup>b</sup>  
   of Jehoahaz . . . . . 1575<sup>a</sup> (Genung)  
   Sixth king of Judah . . . . . 83<sup>a</sup>  
 Ahban . . . . . 83<sup>b</sup>  
 Aher . . . . . 83<sup>b</sup>  
   of Ahi . . . . . 86<sup>a</sup> (Beecher)  
 Ahi, Ah . . . . . 83<sup>b</sup>; 6<sup>b</sup>  
   of Abijah . . . . . 10<sup>a</sup> (Beecher)  
   of Names, Proper . . . . . 2113<sup>a</sup> (Davis)  
 Ahiah . . . . . 83<sup>b</sup>  
 Ahiam . . . . . 83<sup>b</sup>  
 Ahian . . . . . 83<sup>b</sup>  
 Ahiezer . . . . . 83<sup>b</sup>  
 Ahihud . . . . . 83<sup>b</sup>  
 Ahijah . . . . . 83<sup>b</sup> (Beecher)  
   of Ahimelech . . . . . 85<sup>a</sup>  
 Ahikam . . . . . 84<sup>a</sup> (Beecher)  
   of Uriah . . . . . 3040<sup>a</sup> (Easton)



- Ahilud . . . . . 84<sup>b</sup>  
 Ahimaaz . . . . . 84<sup>b</sup> (Beecher)  
 Ahiman . . . . . 84<sup>b</sup> (Beecher)  
 Ahimelech . . . . . 85<sup>a</sup> (Beecher)  
   cf Ahijah . . . . . 83<sup>b</sup> (Beecher)  
   cf Abiathar . . . . . 7<sup>b</sup> (Beecher)  
   cf Ahitub . . . . . 86<sup>b</sup> (Beecher)  
 Ahimoth . . . . . 85<sup>b</sup>  
 Ahinadab . . . . . 85<sup>b</sup>  
 Ahinoam . . . . . 85<sup>b</sup> (Beecher)  
 Ahio . . . . . 85<sup>b</sup> (Beecher)  
   cf Ostraca . . . . . 220<sup>2b</sup> (Goodspeed)  
 Ahira . . . . . 86<sup>a</sup>  
 Ahiram . . . . . 86<sup>a</sup> (Beecher); 80<sup>b</sup>  
   cf Aher . . . . . 83<sup>b</sup>  
   cf Ehi . . . . . 916<sup>a</sup>  
 Ahiramite . . . . . 86<sup>b</sup>  
 Ahisamach . . . . . 86<sup>a</sup>  
 Ahishahar . . . . . 86<sup>a</sup>  
 Ahishar . . . . . 86<sup>a</sup>  
 Ahithophel . . . . . 86<sup>a</sup> (Beecher)  
 Ahitob . . . . . 86<sup>b</sup>  
 Ahitub . . . . . 86<sup>b</sup> (Beecher)  
   cf Abiathar . . . . . 7<sup>b</sup> (Beecher)  
   cf Abitub . . . . . 13<sup>b</sup>  
   cf Acitho . . . . . 37<sup>b</sup>  
   cf Ahijah . . . . . 83<sup>b</sup> (Beecher)  
   cf Ahimelech . . . . . 85<sup>a</sup> (Beecher)  
 Ahlab . . . . . 87<sup>a</sup>  
 Ahlai . . . . . 87<sup>a</sup>  
 Ahoah . . . . . 87<sup>a</sup>  
 Abohite . . . . . 87<sup>a</sup>  
 Aholah (Oholah) . . . . . 2181<sup>a</sup>  
 Aholiab (Oholiab) . . . . . 2181<sup>a</sup>  
 Aholibah (Oholibah) . . . . . 2181<sup>a</sup> (W. W. Davies)  
 Aholibamah (Oholibamah) . . . . . 2181<sup>a</sup>  
 Ahumai . . . . . 87<sup>a</sup>  
 Ahura Mazda (Persian Religion) . . . . . 2332<sup>a</sup> (Tisdall)  
 Ahuzzam . . . . . 87<sup>a</sup>  
 Ahuzzath . . . . . 87<sup>a</sup>  
 Ahzai . . . . . 87<sup>b</sup>  
 Ai . . . . . 87<sup>b</sup> (Mack)  
 Aiah . . . . . 88<sup>a</sup>  
 Aiath . . . . . 88<sup>a</sup>; 87<sup>b</sup>  
 Aid . . . . . 88<sup>a</sup> (Pratt)  
 Aida . . . . . 55<sup>b</sup>  
   cf Hadid . . . . . 1315<sup>b</sup>  
 Aija . . . . . 88<sup>a</sup>; 87<sup>b</sup>  
 Aijalon . . . . . 88<sup>a</sup> (Mack)  
 Aijeleth Hash-shahar  
   cf Song . . . . . 2830<sup>b</sup> (Millar)  
 Ail . . . . . 88<sup>a</sup>  
 Aim . . . . . 88<sup>b</sup>  
 Ain . . . . . 88<sup>b</sup> (W. W. Davies)  
   cf Ayin . . . . . 342<sup>a</sup> (W. W. Davies)  
 Air . . . . . 88<sup>b</sup> (T. Lewis)  
 Airus . . . . . 88<sup>b</sup>  
 Ajah . . . . . 88<sup>b</sup>  
   cf Aiah . . . . . 88<sup>a</sup>  
 Ajalon (Aijalon) . . . . . 88<sup>a</sup> (Mack)  
 Akan . . . . . 88<sup>b</sup>  
   cf Beeroth Bene-jaakan 424<sup>b</sup>  
 Akatan . . . . . 88<sup>b</sup>  
   cf Hakkatan . . . . . 1321<sup>b</sup>  
 Akeldama . . . . . 89<sup>a</sup> (Masterman)  
   cf Hinnom, Valley of, 1393<sup>b</sup> (Masterman)  
 Akkad, Akkadians  
   cf Babylonia . . . . . 365<sup>a</sup> (Clay)  
 Akkos . . . . . 89<sup>a</sup>; 34<sup>b</sup>  
   cf Hakkoz . . . . . 1321<sup>b</sup>  
 Akkub . . . . . 89<sup>a</sup>  
   cf Iacubus . . . . . 1446<sup>a</sup>  
   cf Jacubus . . . . . 1557<sup>a</sup>  
 Akra  
   cf Jerusalem . . . . . 1613<sup>b</sup> (Masterman)  
 Akrabattine . . . . . 89<sup>a</sup>  
 Akrabbim . . . . . 89<sup>a</sup>  
   Pass of  
     cf Sela . . . . . 2713<sup>b</sup> (Ewing)  
 Alabaster . . . . . 80<sup>a</sup>  
   cf Box . . . . . 512<sup>a</sup>  
 Alameth . . . . . 89<sup>b</sup>  
   cf Alemeth . . . . . 90<sup>a</sup>  
 Alammelech . . . . . 89<sup>a</sup>  
   cf Allammelech . . . . . 97<sup>b</sup>  
 Alamothe  
   cf Music . . . . . 2094<sup>b</sup> (Millar)  
 Alarm . . . . . 89<sup>b</sup> (W. W. Davies)  
 Albeit . . . . . 89<sup>b</sup>  
 Alcimus . . . . . 89<sup>b</sup> (Mack)  
 Alcove . . . . . 89<sup>b</sup>  
 Alema . . . . . 89<sup>b</sup>  
 Alemeth . . . . . 90<sup>a</sup>  
   cf Alameth . . . . . 89<sup>b</sup>  
   cf Allemeth . . . . . 98<sup>b</sup>  
 Aleph . . . . . 90<sup>a</sup> (Richardson)  
   cf Alphabet . . . . . 103<sup>b</sup> (Richardson)  
 Aleppo  
   cf Beroea . . . . . 440<sup>a</sup> (Ewing)  
 Alexander . . . . . 90<sup>a</sup> (Rutherford)  
   cf Hymenaeus . . . . . 1444<sup>a</sup> (Rutherford)  
 Alexander Balas . . . . . 91<sup>a</sup> (Fortune); 1141<sup>a</sup>  
 Alexander the Great . . . . . 91<sup>b</sup> (J. E. H. Thomson);  
   456<sup>b</sup> (Dosker)  
   In Asia Minor . . . . . 274<sup>b</sup> (Calder)  
   cf Macedonia . . . . . 1957<sup>a</sup> (Tod)  
 Alexandria . . . . . 93<sup>a</sup> (Cobern)  
   Alexandrian Judaism . . . . . 857<sup>a</sup> (Nicol)  
   Christian church in . . . . . 95<sup>b</sup>  
   Codex . . . . . 94<sup>b</sup>  
   Jews in . . . . . 93<sup>b</sup>  
   cf Septuagint . . . . . 2723<sup>a</sup> (Thackeray)  
   cf Trade . . . . . 3002<sup>a</sup> (Easton)  
   University of . . . . . 95<sup>a</sup>  
 Alexandrian Library . . . . . 456<sup>b</sup> (Dosker)  
 Alexandrians . . . . . 96<sup>b</sup>  
 Algum, Almug . . . . . 96<sup>b</sup> (Masterman)  
 Aliah . . . . . 97<sup>a</sup>  
 Alian . . . . . 97<sup>a</sup>  
 Alien . . . . . 97<sup>a</sup> (Hirsch)  
   cf Foreigner . . . . . 1128<sup>a</sup>

- Alienate . . . . . 97<sup>a</sup> (Jacobs)  
 Alive . . . . . 97<sup>a</sup> (Pratt)  
 All . . . . . 97<sup>b</sup> (M. O. Evans)  
   cf Pentateuch . . . . . 2309<sup>b</sup> (Wiener)  
 Allammelech . . . . . 97<sup>b</sup>  
 Allar . . . . . 97<sup>b</sup>  
 Allay . . . . . 97<sup>b</sup>  
 Allege . . . . . 97<sup>b</sup>  
 Allegiance . . . . . 97<sup>b</sup>  
 Allegory . . . . . 97<sup>b</sup> (Schodde)  
   cf Accommodation . . . . . 29<sup>b</sup> (Sweet)  
   cf Fable . . . . . 1085<sup>a</sup> (Easton)  
 Alleluia (Hallelujah) . . . . . 1323<sup>a</sup> (Breslich)  
 Allemeth . . . . . 98<sup>b</sup>  
   cf Alemeth . . . . . 90<sup>a</sup>  
 Alliance . . . . . 98<sup>b</sup> (Cohon)  
   cf Covenant . . . . . 727<sup>a</sup> (Berry)  
 Allied . . . . . 99<sup>b</sup>  
 Allom . . . . . 99<sup>b</sup>  
 Allon . . . . . 99<sup>b</sup>  
 Allon-bacuth . . . . . 99<sup>b</sup>  
 Allow, Allowance . . . . . 99<sup>b</sup> (Edwards)  
 Alloy . . . . . 99<sup>b</sup>  
   cf Tin . . . . . 2985<sup>b</sup>  
 Allure . . . . . 99<sup>b</sup> (M. O. Evans)  
 Almighty . . . . . 100<sup>a</sup>  
   cf God, Names of . . . . . 1264<sup>b</sup> (Mack)  
 Almodad . . . . . 100<sup>a</sup>  
   cf Abimael . . . . . 11<sup>a</sup> (Beecher)  
 Almon . . . . . 100<sup>a</sup>  
   cf Allemeth . . . . . 98<sup>b</sup>  
 Almon-diblahaim . . . . . 100<sup>a</sup>  
 Almond . . . . . 100<sup>a</sup> (Masterman)  
   cf Bethel . . . . . 443<sup>b</sup> (Ewing)  
   cf Candlestick, Golden 553<sup>a</sup> (Orr)  
   cf Flourish . . . . . 1120<sup>a</sup> (W. L. Walker)  
   Rod of . . . . . 100<sup>b</sup>  
 Almost . . . . . 100<sup>b</sup> (Harry)  
   cf Fain . . . . . 1086<sup>b</sup> (W. L. Walker)  
 Alms, Alms-giving . . . . . 101<sup>b</sup> (Eager)  
   cf Poor . . . . . 2420<sup>a</sup> (W. L. Walker)  
 Almug (Algum) . . . . . 96<sup>b</sup> (Masterman)  
 Alnathan . . . . . 102<sup>b</sup>  
 Aloes . . . . . 102<sup>b</sup> (Masterman)  
 Aloft . . . . . 103<sup>b</sup>  
 Along . . . . . 103<sup>b</sup>  
 Aloth . . . . . 103<sup>b</sup>  
 Alpha and Omega . . . . . 103<sup>b</sup> (Harry)  
 Alphabet . . . . . 103<sup>b</sup> (Richardson)  
   cf Acrostic . . . . . 38<sup>a</sup> (Smith)  
   cf Qadhe . . . . . 536<sup>a</sup>  
   cf He . . . . . 1348<sup>a</sup>  
   cf Heth . . . . . 1384<sup>b</sup>  
   cf Jod . . . . . 1688<sup>a</sup>  
   cf Kaph . . . . . 1789<sup>b</sup>  
   cf Koph . . . . . 1816<sup>b</sup>  
   cf Lamedh . . . . . 1824<sup>a</sup>  
   cf Mem . . . . . 2030<sup>a</sup>  
   cf Nun . . . . . 2170<sup>a</sup>  
   cf Pe . . . . . 2293<sup>a</sup>  
   cf Phoenicia . . . . . 2389<sup>a</sup> (Porter)
- Alphabet—*continued*  
   cf Resh . . . . . 2561<sup>a</sup>  
   cf Samech . . . . . 2674<sup>a</sup>  
   cf Shin, Sin . . . . . 2771<sup>a</sup>  
   cf Taw . . . . . 2918<sup>a</sup>  
   cf Teth . . . . . 2950<sup>a</sup>  
   cf Text of OT . . . . . 2958<sup>a</sup> (Weir)  
   cf Waw . . . . . 3075<sup>b</sup>  
   cf Writing . . . . . 3118<sup>b</sup> (Richardson)  
   cf Yodh . . . . . 3126<sup>a</sup>  
   cf Zayin . . . . . 3133<sup>a</sup>  
 Alphaeus . . . . . 106<sup>a</sup> (Fortune)  
   cf Clopas . . . . . 669<sup>b</sup> (Jacobs)  
   cf Mary (wife of  
     Clopas) . . . . . 2001<sup>b</sup> (Sweet)  
 Also . . . . . 106<sup>b</sup>  
 Altaneus (Maltanneus) . . . . . 1972<sup>b</sup>  
 Altar . . . . . 106<sup>b</sup> (Wiener)  
   Of Abaz . . . . . 109<sup>a</sup>  
   Of burnt offering . . . . . 110<sup>b</sup>  
     cf Horns of Altar . . . . . 1422<sup>b</sup> (Caldecott)  
     cf Tabernacle . . . . . 2889<sup>a</sup> (Caldecott; Orr)  
     cf Temple, Herod's 2937<sup>a</sup> (Caldecott; Orr)  
   Critical . . . . . 106<sup>b</sup> (Wiener)  
   Of Gezer . . . . . 110<sup>a</sup>  
   Hebrew altars . . . . . 107<sup>a</sup>  
   Horned altar . . . . . 108<sup>b</sup>  
     cf Horn . . . . . 1422<sup>a</sup> (Easton)  
     cf Horns of Altar . . . . . 1422<sup>b</sup> (Caldecott)  
   Idoltrous altars . . . . . 109<sup>b</sup>  
   Of incense . . . . . 109<sup>b</sup>  
     cf Holy Place . . . . . 1405<sup>b</sup> (Caldecott)  
     cf Horns of Altar . . . . . 1422<sup>b</sup> (Caldecott)  
     cf Incense . . . . . 1466<sup>b</sup> (Orr)  
     cf Mercy-seat . . . . . 2036<sup>a</sup> (Caldecott)  
     At Taanach . . . . . 110<sup>a</sup>  
     cf Tabernacle . . . . . 2891<sup>a</sup> (Caldecott; Orr)  
     cf Table of Shew-  
       bread . . . . . 2767<sup>b</sup> (Caldecott)  
   Of Joshua . . . . . 108<sup>b</sup>  
     cf High Place . . . . . 1390<sup>a</sup> (Easton)  
   cf Ledge . . . . . 1864<sup>b</sup>  
   cf Mercy-seat . . . . . 2036<sup>a</sup> (Caldecott)  
   Patriarchal altars . . . . . 110<sup>b</sup>  
     cf Pentateuch . . . . . 2309<sup>b</sup> (Wiener)  
   Post-exilic altar . . . . . 109<sup>b</sup>  
   Pre-Mosaic altar . . . . . 107<sup>b</sup>  
   Pre-tabernacle altars . . . . . 110<sup>b</sup>  
   cf Sacrifice . . . . . 2646<sup>a</sup> (Reeve)  
   cf Sanctuary . . . . . 2686<sup>b</sup> (Wiener)  
   cf Staves . . . . . 2850<sup>a</sup> (Caldecott)  
   cf Tabernacle . . . . . 2889<sup>a</sup> (Caldecott; Orr)  
   Tabernacle altar . . . . . 108<sup>b</sup>  
     cf Asylum . . . . . 316<sup>b</sup> (Wiener)  
   cf Table of Shew-  
     bread . . . . . 2767<sup>b</sup> (Caldecott)  
   cf Temple . . . . . 2938<sup>a</sup> (Caldecott; Orr)  
   cf Tongs . . . . . 2994<sup>a</sup>  
   cf Uriah . . . . . 3039<sup>b</sup> (Easton)  
   In worship . . . . . 110<sup>b</sup> (Caldecott)  
     cf Worship . . . . . 3111<sup>a</sup> (Crannell)

- Altashheth, Altaschith  
 of Psalms, Book of . . . 2487<sup>a</sup> (Sampey)  
 of Song . . . . . 2830<sup>b</sup> (Millar)  
 Altogether . . . . . 112<sup>a</sup> (Pratt)  
 of Almost . . . . . 100<sup>b</sup> (Harry)  
 Alush . . . . . 112<sup>b</sup>  
 of Wanderings of Israel 3064<sup>a</sup> (Conder)  
 Alvah . . . . . 112<sup>b</sup>  
 Alvan . . . . . 112<sup>b</sup>  
 Alway . . . . . 112<sup>b</sup>  
 Amad . . . . . 112<sup>a</sup>  
 Amadatha, Amadathus  
 of Hammedatha . . . . . 1325<sup>b</sup>  
 Amain . . . . . 112<sup>b</sup>  
 Amal . . . . . 112<sup>b</sup>  
 Amalek, Amalekite . . . . . 112<sup>b</sup> (Porter); 217<sup>a</sup>  
 of Joshua . . . . . 1743<sup>a</sup> (Geden)  
 of Mount of Amale-  
 kites . . . . . 2092<sup>b</sup>  
 Amam . . . . . 113<sup>a</sup>  
 Aman . . . . . 113<sup>a</sup>  
 of Nasbas . . . . . 2120<sup>a</sup> (Angus)  
 Amana . . . . . 113<sup>a</sup> (C. H. Thomson)  
 of Abanah . . . . . 3<sup>a</sup> (C. H. Thomson)  
 Amariah . . . . . 113<sup>b</sup> (Breslich)  
 Amarias . . . . . 113<sup>b</sup>  
 Amarna, Tell el- . . . . . 2925<sup>b</sup> (Kyle)  
 of Archaeology and  
 Criticism . . . . . 226<sup>a</sup> (Kyle)  
 Canaanite civilization . 2927<sup>a</sup>  
 Cuneiform writing . . . 2926<sup>a</sup>  
 Diplomatic correspond-  
 ence . . . . . 2927<sup>b</sup>  
 Discovery . . . . . 2925<sup>b</sup>  
 Egyptian rule, but  
 Babylonian lan-  
 guage . . . . . 2927<sup>b</sup>  
 Geographical value . . 2926<sup>b</sup>  
 of Heberites . . . . . 1354<sup>b</sup>  
 of Hebrew . . . . . 1355<sup>a</sup> (Orr)  
 Historical value . . . . 2926<sup>b</sup>  
 of Jerusalem . . . . . 1613<sup>b</sup> (Masterman)  
 of Libraries . . . . . 1882<sup>a</sup> (Richardson)  
 of Melchizedek . . . . 2028<sup>b</sup> (Roberts)  
 of Moses . . . . . 2083<sup>b</sup> (Kyle)  
 Name . . . . . 2925<sup>b</sup>  
 of Palestine, Recent  
 Exploration . . . . . 2223<sup>a</sup> (Cobern)  
 Philological value . . . 2926<sup>b</sup>  
 Physical character . . . 2726<sup>a</sup>  
 Problem of the Habiri 2927<sup>b</sup>  
 Proper names . . . . . 2926<sup>a</sup>  
 of Sidon . . . . . 2785<sup>b</sup> (Porter)  
 Verification of Biblical  
 statements . . . . . 2926<sup>b</sup>  
 Amasa . . . . . 113<sup>b</sup> (Wolf)  
 of Joab . . . . . 1678<sup>a</sup> (Roberts)  
 Amasai . . . . . 114<sup>a</sup>  
 Amashsai . . . . . 114<sup>a</sup>  
 Amasiah . . . . . 114<sup>a</sup>  
 Amath, Amathis (Ha-  
 math) . . . . . 1324<sup>b</sup> (Christie)
- Amatheis (Ematheis) . . . 940<sup>a</sup>  
 Amazed . . . . . 114<sup>a</sup> (Pratt)  
 Amaziah . . . . . 114<sup>a</sup> (Caldecott)  
 Ambassador . . . . . 115<sup>a</sup> (Pratt)  
 of Concordance . . . . 696<sup>b</sup> (Orr)  
 Ambassage . . . . . 115<sup>a</sup>  
 Amber  
 of Stones, Precious . . . 2856<sup>a</sup> (Fletcher)  
 Ambitious . . . . . 115<sup>b</sup>  
 Ambush . . . . . 115<sup>b</sup>  
 Ambushment . . . . . 115<sup>b</sup> (Nicol)  
 Amen . . . . . 115<sup>a</sup> (Millar)  
 Amerce . . . . . 115<sup>b</sup>  
 American Revised Ver-  
 sion . . . . . 116<sup>a</sup> (Easton)  
 of English Versions . . 951<sup>b</sup> (Hutchison)  
 Amethyst  
 of Stones, Precious . . . 2856<sup>a</sup> (Fletcher)  
 Ami . . . . . 116<sup>b</sup>  
 Amiable . . . . . 116<sup>b</sup> (M. O. Evans)  
 of Tabernacle . . . . . 2887<sup>b</sup> (Caldecott; Orr)  
 Aminadab . . . . . 116<sup>b</sup>  
 Amiss . . . . . 116<sup>b</sup>  
 Amittai . . . . . 117<sup>a</sup>  
 Ammah . . . . . 117<sup>a</sup>  
 of Gibeath . . . . . 1225<sup>b</sup> (Ewing)  
 Ammi . . . . . 117<sup>a</sup>  
 Ammidioi . . . . . 117<sup>a</sup>  
 Ammiel . . . . . 117<sup>a</sup> (Mack)  
 Ammihud . . . . . 117<sup>a</sup> (Mack)  
 Ammihur . . . . . 117<sup>a</sup>; 117<sup>b</sup>  
 Amminadab . . . . . 117<sup>b</sup> (T. Lewis)  
 Amminadib . . . . . 117<sup>b</sup>  
 Ammishaddai . . . . . 117<sup>a</sup>  
 Ammizabad . . . . . 117<sup>b</sup>  
 Ammon, Ammonites . . . 117<sup>b</sup> (Porter)  
 of Jephthah . . . . . 1587<sup>a</sup> (Schenk)  
 Name . . . . . 117<sup>b</sup>  
 Religion . . . . . 118<sup>a</sup>  
 War with Jotham . . . . 1754<sup>a</sup> (Caldecott)  
 Ammonites . . . . . 118<sup>a</sup>  
 Amnon . . . . . 118<sup>a</sup>  
 of Tamar . . . . . 2907<sup>b</sup> (Orr)  
 Amok . . . . . 118<sup>b</sup>  
 Amon . . . . . 118<sup>b</sup> (Genung)  
 of Josiah . . . . . 1752<sup>a</sup> (Genung)  
 Amorites . . . . . 119<sup>a</sup> (Sayce); 446<sup>b</sup>  
 of Mount of Amorites 2092<sup>b</sup>  
 Amos . . . . . 120<sup>a</sup> (J. Robertson)  
 Book of . . . . . 122<sup>b</sup>  
 Contents, analysis of . . 122<sup>a</sup>  
 Date . . . . . 121<sup>b</sup>  
 of Israel, Religion of . . 1538<sup>b</sup> (Orelli)  
 of Jeroboam II . . . . . 1594<sup>b</sup> (Caldecott)  
 Mission . . . . . 121<sup>b</sup>  
 Name . . . . . 120<sup>b</sup>  
 Native place . . . . . 120<sup>b</sup>  
 Personal history . . . . 120<sup>b</sup>  
 Preparation . . . . . 121<sup>a</sup>  
 of Tekoa . . . . . 2924<sup>a</sup> (Masterman)  
 Amos (Lk 3 25) . . . . . 125<sup>a</sup>  
 Amoz . . . . . 125<sup>b</sup>

- Amphipolis . . . . . 125<sup>b</sup> (Tod)  
 Amplias . . . . . 125<sup>b</sup>  
 Ampliatus . . . . . 125<sup>b</sup>  
 Amram . . . . . 125<sup>b</sup> (Mack)  
 Amramites . . . . . 126<sup>a</sup>  
 Amraphel . . . . . 126<sup>a</sup> (Pinches); 366<sup>a</sup> (Clay)  
   of Arioch . . . . . 241<sup>a</sup> (Pinches)  
   of Chedorlaomer . . . . . 599<sup>a</sup> (Pinches)  
   of Eri-aku . . . . . 969<sup>b</sup> (Pinches)  
   of Hammurabi . . . . . 1326<sup>a</sup> (Pinches)  
   of Pentateuch . . . . . 2305<sup>a</sup> (Wiener)  
   of Tidal . . . . . 2980<sup>a</sup> (Pinches)  
 Amulet . . . . . 126<sup>b</sup> (T. W. Davies)  
   of Charm . . . . . 597<sup>b</sup> (T. W. Davies)  
   of Magic, Magician . . . . . 1963<sup>a</sup> (T. W. Davies)  
   of Nose-jewels . . . . . 2156<sup>a</sup> (Pollard)  
 Amzi . . . . . 128<sup>a</sup>  
 Anab . . . . . 128<sup>a</sup>  
 Anael . . . . . 128<sup>a</sup>  
 Anah . . . . . 128<sup>a</sup> (Wolf)  
 Anaharith . . . . . 128<sup>b</sup>  
 Anaiah . . . . . 128<sup>b</sup>  
 Anak (Anakim) . . . . . 128<sup>b</sup> (Sayce)  
 Anakim . . . . . 128<sup>b</sup> (Sayce)  
   of Rephaim . . . . . 2559<sup>b</sup> (Porter)  
 Ananim . . . . . 129<sup>a</sup>  
   of Table of Nations . . . . . 2893<sup>b</sup> (Pinches)  
 Anammelech . . . . . 129<sup>a</sup> (Wolf)  
   of Adrammelech . . . . . 61<sup>b</sup> (Beecher)  
 Anan . . . . . 129<sup>a</sup>  
 Anani . . . . . 129<sup>a</sup>  
 Ananiah . . . . . 129<sup>a</sup>  
 Ananias . . . . . 129<sup>a</sup> (Edwards)  
   of Hananiah . . . . . 1333<sup>a</sup> (Reeve)  
   of Sapphira . . . . . 2690<sup>b</sup>  
 Ananias (Apoc) . . . . . 130<sup>a</sup> (Edwards)  
 Ananiel . . . . . 130<sup>a</sup>  
 Anath . . . . . 130<sup>a</sup>  
 Anathema . . . . . 130<sup>a</sup> (T. Lewis)  
   of Accursed . . . . . 34<sup>b</sup> (T. Lewis)  
 Anathoth . . . . . 130<sup>b</sup> (Ewing)  
   of Jeremiah . . . . . 1588<sup>a</sup> (Orelli)  
 Anathothite . . . . . 130<sup>b</sup>  
 Anaxagoras  
   of Logos . . . . . 1912<sup>a</sup> (Alexander)  
 Ancestors . . . . . 130<sup>b</sup>  
 Anchor  
   of Ships and Boats . . . . . 2777<sup>a</sup> (Nicol)  
 Ancient . . . . . 130<sup>b</sup> (T. Lewis); 131<sup>a</sup>  
 Ancient of Days . . . . . 130<sup>b</sup>  
 Ancients . . . . . 131<sup>a</sup> (T. Lewis)  
 Ancle (Ankle) . . . . . 136<sup>a</sup>  
 Andrew . . . . . 131<sup>a</sup> (Carr)  
   In apocryphal lit . . . . . 131<sup>b</sup>  
   Character . . . . . 132<sup>a</sup>  
   of James, Son of  
     Zebedee . . . . . 1560<sup>a</sup> (Kerr)  
   of Matthias . . . . . 2012<sup>a</sup> (Kerr)  
   In NT . . . . . 131<sup>a</sup>  
   of Philip . . . . . 2368<sup>a</sup> (Kerr)  
 Andronicus . . . . . 132<sup>a</sup> (Jacobs)  
 Anem . . . . . 132<sup>a</sup>  
 Aner . . . . . 132<sup>b</sup> (Cohon)  
 Aner (place) . . . . . 132<sup>b</sup>  
 Anethothite (Anatho-  
   thite) . . . . . 130<sup>b</sup>  
 Anethothite (Anathothite) 130<sup>b</sup>  
 Angel . . . . . 132<sup>b</sup> (J. M. Wilson)  
   In NT . . . . . 134<sup>a</sup>  
     of Abaddon . . . . . 2<sup>b</sup> (Beecher)  
     of Apollyon . . . . . 201<sup>b</sup> (Sweet)  
     of Host of Heaven . . . . . 1433<sup>b</sup> (Orr)  
     of Jesus Christ . . . . . 1633<sup>a</sup> (Orr)  
     of Mediation . . . . . 2020<sup>b</sup> (Edwards)  
     of Principality . . . . . 2454<sup>b</sup> (Heidel)  
     Reality of . . . . . 135<sup>a</sup>  
     Teachings of Jesus . . . . . 134<sup>b</sup>  
   In OT . . . . . 133<sup>a</sup>  
     Angel Gabriel . . . . . 133<sup>b</sup>; 1151<sup>a</sup> (Orr)  
     Angel of Jehovah . . . . . 133<sup>b</sup>  
     Archangel . . . . . 133<sup>a</sup>  
     of Cherub . . . . . 603<sup>b</sup>  
     of Demon . . . . . 827<sup>b</sup> (Sweet)  
     of Satan . . . . . 2693<sup>b</sup> (Sweet)  
 Angel of God  
   of Angel . . . . . 132<sup>b</sup> (J. M. Wilson)  
 Angel of Jehovah  
   of Angel . . . . . 133<sup>b</sup> (J. M. Wilson)  
 Angels of the Seven  
   Churches . . . . . 135<sup>b</sup> (Banks)  
 Anger . . . . . 135<sup>b</sup> (Farr)  
   of Fury . . . . . 1150<sup>b</sup>  
   of Wrath . . . . . 3113<sup>a</sup> (W. Evans)  
 Angle . . . . . 135<sup>b</sup>  
 Angling . . . . . 136<sup>a</sup>  
   of Fishing . . . . . 1116<sup>a</sup> (Patch)  
 Anglo-Saxon Versions  
   of English Versions . . . . . 945<sup>b</sup> (Hutchison)  
 Anguish . . . . . 136<sup>a</sup> (Pratt)  
 Aniam . . . . . 136<sup>a</sup>  
 Anim . . . . . 136<sup>a</sup> (Masterman)  
 Animal . . . . . 136<sup>a</sup>  
 Animal Foods . . . . . 1123<sup>a</sup> (Eager)  
 Animism  
   of Israel, Religion of . . . . . 1532<sup>a</sup> (Orelli)  
 Anise or Dill . . . . . 136<sup>a</sup> (Masterman)  
 Ankle . . . . . 136<sup>a</sup>  
 Anklet, Ankle-chain . . . . . 136<sup>b</sup> (Eager)  
 Anna . . . . . 136<sup>b</sup> (Pratt)  
 Annaas . . . . . 137<sup>a</sup>  
 Annas . . . . . 137<sup>a</sup> (Edwards)  
   of Jesus Christ, Arrest . . . . . 1670<sup>a</sup> (Maclaren)  
   of Priest, High . . . . . 2441<sup>b</sup> (Reeve)  
 Annis . . . . . 137<sup>b</sup>  
 Annul, Disannul . . . . . 137<sup>b</sup> (Hirsch)  
 Annunciation, The  
   of Jesus Christ . . . . . 1631<sup>b</sup> (Orr)  
 Annus . . . . . 137<sup>b</sup>  
 Annuus . . . . . 138<sup>a</sup>  
 Anoint . . . . . 138<sup>a</sup> (Kapp)  
 Anointing . . . . . 138<sup>a</sup> (Eager)  
   of Oil, Anointing . . . . . 2183<sup>a</sup> (Orr)  
   of Ointment . . . . . 2183<sup>a</sup> (Patch)  
 Uses . . . . . 138<sup>a</sup>

- Anon. . . . . 138<sup>b</sup>  
 Anos. . . . . 138<sup>b</sup>  
 Anro Mainyus (Ahriman)  
   cf Persian Religion . . . 2333<sup>a</sup> (Tisdall)  
 Answer. . . . . 138<sup>b</sup> (Gerberding)  
 Answerable. . . . . 139<sup>a</sup>  
 Ant. . . . . 139<sup>a</sup> (Day)  
 Antediluvian Patriarchs. 139<sup>a</sup> (Davis)  
   cf Chronology of OT. . . 635<sup>a</sup> (Mack)  
   cf Patriarch . . . . . 2264<sup>a</sup> (Orr)  
 Antediluvians . . . . . 143<sup>a</sup> (Wright)  
   cf Deluge of Noah. . . . 821<sup>b</sup> (Wright)  
   cf Giants . . . . . 1224<sup>b</sup> (Orr)  
   cf Life . . . . . 1888<sup>a</sup> (Reeve)  
   cf Noah . . . . . 2153<sup>a</sup> (Wright)  
   cf Patriarch . . . . . 2264<sup>a</sup> (Orr)  
   cf Sons of God (OT). . . 2835<sup>a</sup> (Crichton)  
 Antelope. . . . . 143<sup>b</sup> (Day)  
   cf Wild-ox . . . . . 3084<sup>b</sup> (Day)  
 Anthon. . . . . 144<sup>b</sup>  
 Anthothijah. . . . . 144<sup>b</sup>  
 Anthropology. . . . . 144<sup>b</sup> (Marais)  
   Antiquity of man. . . . 151<sup>a</sup>  
   Evolutionary theory. . . 148<sup>a</sup>; 1043<sup>a</sup> (Zenos)  
   cf God, Image of. . . . 1264<sup>b</sup> (Orr)  
   Nature of man. . . . . 145<sup>b</sup>  
   Origin of man. . . . . 146<sup>b</sup>  
   Primitive and present  
     conditions of man. . . 150<sup>b</sup>; 635<sup>a</sup> (Mack)  
   Unity of race. . . . . 147<sup>b</sup>  
   cf Woman . . . . . 3100<sup>a</sup> (Pratt)  
   cf World, Cosmologi-  
     cal . . . . . 3106<sup>a</sup> (Orr)  
 Anthropomorphism. . . . 152<sup>b</sup> (J. Lindsay)  
 Antichrist. . . . . 154<sup>a</sup> (J. E. H. Thomson)  
   In apocalyptic writ-  
     ings . . . . . 155<sup>b</sup>  
   cf Johannine The-  
     ology. . . . . 1705<sup>b</sup> (Law)  
   cf Man of Sin . . . . . 1976<sup>a</sup> (Orr)  
   Mediaeval views. . . . 156<sup>a</sup>  
   In NT and OT. . . . . 154<sup>b</sup>  
   cf Parousia . . . . . 2249<sup>a</sup> (Easton)  
   In patristic writings. . 155<sup>b</sup>  
   Post-reformation views 156<sup>a</sup>  
   cf Zoroastrianism. . . . 3157<sup>a</sup> (Easton)  
 Antilegomena  
   cf Bible . . . . . 459<sup>b</sup> (Orr)  
   cf Canon of NT. . . . . 563<sup>a</sup> (Riggs)  
   cf Deutero-canonical  
     Books. . . . . 834<sup>b</sup> (Fortune)  
 Anti-Libanus (Lebanon) 1862<sup>b</sup> (Wright)  
 Antimony  
   cf Color . . . . . 674<sup>b</sup> (Patch)  
 Antinomianism  
   In 1 John . . . . . 1713<sup>b</sup> (Law)  
 Antioch of Pisidia. . . . 156<sup>b</sup> (Calder)  
   cf Galatia . . . . . 1154<sup>a</sup> (Ramsay)  
   cf Pisidia . . . . . 2400<sup>b</sup> (Calder)  
 Antioch in Syria. . . . . 157<sup>b</sup> (C. H. Thomson)  
   cf Lystra . . . . . 1944<sup>a</sup> (Calder)  
   cf Trade . . . . . 3002<sup>a</sup> (Easton)  
 Antiochians . . . . . 158<sup>a</sup> (Pratt)  
 Antiochis. . . . . 158<sup>b</sup>  
 Antiochus. . . . . 158<sup>b</sup>  
   cf Tryphon . . . . . 3027<sup>a</sup> (Angus)  
 Antiochus I. . . . . 158<sup>b</sup> (Harry)  
   cf Seleucus. . . . . 2715<sup>a</sup> (Hutchison)  
 Antiochus II. . . . . 158<sup>b</sup> (Harry)  
 Antiochus III  
   cf Maccabaeus. . . . . 1946<sup>b</sup> (Hutchison)  
 Antiochus IV (Epiph-  
   anes) . . . . . 159<sup>b</sup> (Harry); 158<sup>b</sup> (Pratt);  
     456<sup>b</sup> (Dosker); 558<sup>a</sup>  
   cf Abomination of  
     Desolation . . . . . 17<sup>a</sup> (Hirsch)  
     cf Jerusalem. . . . . 1617<sup>a</sup> (Masterman)  
   And the Maccabees . . . 1946<sup>b</sup> (Hutchison)  
 Antiochus V. . . . . 159<sup>b</sup> (Harry)  
 Antiochus VI. . . . . 159<sup>b</sup> (Harry)  
 Antiochus VII. . . . . 160<sup>a</sup> (Harry)  
 Antipas. . . . . 160<sup>a</sup>  
   cf Herod. . . . . 1378<sup>b</sup> (Dosker)  
 Antipater. . . . . 160<sup>a</sup>  
 Antipatris. . . . . 160<sup>a</sup> (Ewing)  
 Antiquity. . . . . 160<sup>a</sup>  
 Antonia  
   cf Jerusalem . . . . . 1602<sup>b</sup> (Masterman)  
 Anthothijah (Anthothijah) 144<sup>b</sup>  
 Antothite. . . . . 160<sup>a</sup>  
 Anu. . . . . 370<sup>b</sup> (Rogers)  
 Anub. . . . . 160<sup>a</sup>  
 Anus (Annus). . . . . 137<sup>b</sup>  
 Anvil. . . . . 160<sup>a</sup> (Patch)  
 Apace. . . . . 160<sup>b</sup>  
 Apame. . . . . 160<sup>b</sup>  
   cf Bartacus . . . . . 406<sup>b</sup>  
   cf Illustrious . . . . . 1449<sup>b</sup>  
 Apart. . . . . 160<sup>b</sup> (Pratt)  
 Ape. . . . . 160<sup>b</sup> (Day)  
 Apelles. . . . . 160<sup>b</sup> (S. F. Hunter)  
 Aphaerema. . . . . 161<sup>a</sup>  
 Apharsathchites, Aphar-  
   sachites. . . . . 161<sup>a</sup> (Wolf)  
 Apharsites. . . . . 161<sup>a</sup>  
 Aphek. . . . . 161<sup>a</sup> (Ewing)  
 Aphekah. . . . . 161<sup>b</sup>  
 Apherema (Aphaerema). 161<sup>a</sup>  
 Apherra. . . . . 161<sup>b</sup>  
 Aphiah. . . . . 161<sup>b</sup>  
 Aphik. . . . . 161<sup>b</sup>  
 Aphrah (Bethleaphrah). 449<sup>b</sup>  
 Aphses  
   cf Happizzez . . . . . 1336<sup>b</sup>  
 Apocalypse  
   cf Apocalyptic Lit. . . . 161<sup>b</sup> (J. E. H. Thomson)  
   Of Baruch . . . . . 166<sup>b</sup> (J. E. H. Thomson)  
   Book of Jubilees. . . . 173<sup>a</sup>  
   cf Revelation of John. 2582<sup>b</sup> (Orr)  
 Apocalypses  
   Relation of Essenes to 1003<sup>b</sup> (J. E. H. Thomson)  
 Apocalyptic  
   cf Jesus Christ. . . . . 1630<sup>a</sup> (Orr)  
   cf Messiah . . . . . 2041<sup>b</sup> (Crichton)

- Apocalyptic Literature . . . 161<sup>b</sup> (J. E. H. Thomson)
- Antichrist in . . . . . 155<sup>b</sup>
- cf Israel, Religion of . . . 1541<sup>a</sup> (Orelli)
- cf Jesus Christ . . . . . 1627<sup>a</sup> (Orr)
- Judaism and Hellenism . . . . . 162<sup>a</sup>
- Legendary testaments 173<sup>a</sup>
- cf Messiah . . . . . 2042<sup>a</sup> (Crichton)
- cf Paradise . . . . . 2246<sup>a</sup> (Wright)
- Political influences . . . 162<sup>b</sup>
- cf Prophecy . . . . . 2464<sup>a</sup> (Orelli)
- Psalmic pseudepigrapha . . . . . 174<sup>a</sup>
- Pseudonymity . . . . . 163<sup>a</sup>
- Relation to prophecy . . 162<sup>b</sup>
- cf Revelation of John . 2582<sup>b</sup> (Orr)
- cf Rome . . . . . 2620<sup>a</sup> (Allen)
- Sibyline oracles . . . . . 178<sup>a</sup>
- Testaments . . . . . 175<sup>a</sup>
- Typical apocalypses . . . 164<sup>b</sup>
- Apocrypha . . . . . 178<sup>b</sup> (T. W. Davies); 457<sup>b</sup> (Dosker); 951<sup>a</sup> (Hutchison)
- Books included in . . . 182<sup>b</sup>
- Date of apocryphal writings . . . . . 183<sup>a</sup>
- Doctrine in early Greek philosophy . . . . . 179<sup>b</sup>
- cf Hozai . . . . . 1439<sup>a</sup> (McAllister)
- Judith . . . . . 182<sup>a</sup>; 183<sup>a</sup>
- cf Judith, Book of . . . 1773<sup>b</sup> (T. W. Davies)
- cf Maccabees, Books of . 1948<sup>a</sup> (T. W. Davies)
- Original languages of . . 183<sup>a</sup>
- Original meanings . . . 179<sup>a</sup>
- Classical . . . . . 179<sup>a</sup>
- Hellenistic . . . . . 179<sup>b</sup>
- In NT . . . . . 179<sup>b</sup>
- Patristic . . . . . 179<sup>b</sup>
- cf Palestine . . . . . 2220<sup>a</sup> (Conder)
- References to, in Jude 1770<sup>a</sup> (Moorehead)
- cf Tobit, Book of . . . 2990<sup>b</sup> (T. W. Davies)
- Usage . . . . . 179<sup>b</sup>
- Early Christian . . . . . 180<sup>a</sup>
- In eastern church . . . 180<sup>a</sup>
- By reformers . . . . . 181<sup>b</sup>
- In western church . . . 181<sup>b</sup>
- Apocryphal Acts . . . . . 183<sup>b</sup> (A. F. Findlay)
- Acts of Andrew . . . . . 192<sup>b</sup>
- Acts of John . . . . . 191<sup>b</sup>
- Acts of Paul . . . . . 188<sup>b</sup>
- Acts of Peter . . . . . 190<sup>a</sup>
- Acts of Thomas . . . . . 193<sup>b</sup>
- Authorship . . . . . 187<sup>a</sup>
- Ecclesiastical testimony . . . . . 186<sup>a</sup>
- Among eastern writers . . . . . 186<sup>a</sup>
- Ecclesiastical condemnation . . . . . 186<sup>b</sup>
- Photius . . . . . 186<sup>a</sup>
- Among western writers . . . . . 186<sup>a</sup>
- Apocryphal Acts—*continued*
- Extra-canonical . . . . . 184<sup>a</sup>
- False and heretical . . . 184<sup>a</sup>
- General characteristics . . . . . 184<sup>a</sup>
- Influence . . . . . 187<sup>b</sup>
- cf Literature, Sub-apos 1896<sup>b</sup> (Cowan)
- Meaning of apocryphal 183<sup>b</sup>
- Origin . . . . . 185<sup>a</sup>
- cf Publius . . . . . 2501<sup>a</sup> (Kerr)
- Relationship of different acts . . . . . 187<sup>a</sup>
- Secret . . . . . 184<sup>a</sup>
- Sources . . . . . 185<sup>b</sup>
- Canonical acts . . . . . 185<sup>b</sup>
- Romances of travel . . . 185<sup>b</sup>
- Traditions . . . . . 185<sup>b</sup>
- cf Thaddaeus . . . . . 2964<sup>a</sup> (Kerr)
- Value . . . . . 187<sup>a</sup>
- As history . . . . . 187<sup>a</sup>
- As records of early Christianity . . . . . 187<sup>a</sup>
- Apocryphal Epistles . . . 194<sup>b</sup> (J. M. Wilson)
- cf Laodiceans, Ep. to . . 1837<sup>a</sup> (Rutherford)
- Letter attributed
- To our Lord . . . . . 194<sup>b</sup>
- To Paul . . . . . 195<sup>a</sup>
- To Peter . . . . . 195<sup>a</sup>
- Apocryphal Gospels . . . 195<sup>a</sup> (Hutchison)
- Descent of Jesus . . . . . 200<sup>a</sup>
- Early gospels . . . . . 195<sup>b</sup>
- cf Hebrews, Gospel according to . . . . . 1362<sup>b</sup> (Nicol)
- Heretical gospels . . . . 197<sup>a</sup>
- Of Barnabas and Bartholomew . . . . . 198<sup>a</sup>
- Of the Ebionites . . . . . 197<sup>a</sup>
- Of the Egyptians . . . . . 197<sup>a</sup>
- Of Marcion . . . . . 197<sup>b</sup>
- Of Peter . . . . . 197<sup>b</sup>
- Of Twelve Apostles . . . 198<sup>a</sup>
- Introductory history . . 195<sup>b</sup>
- Apocryphal gospels . . . 196<sup>a</sup>
- Canonical gospels . . . 195<sup>b</sup>
- Early gospels . . . . . 195<sup>b</sup>
- Gospel according to Hebrews . . . . . 196<sup>b</sup>
- cf Jesus Christ . . . . . 1634<sup>a</sup> (Orr)
- cf Literature, Sub-apos 1896<sup>b</sup> (Cowan)
- cf Philip . . . . . 2368<sup>a</sup> (Kerr)
- cf Pilate, Pontius . . . . 2398<sup>a</sup> (J. M. Wilson)
- Supplementary or legendary gospels . . . 198<sup>a</sup>
- Acts of Pilate . . . . . 200<sup>a</sup>
- Arabic Gospel of Childhood . . . . . 199<sup>b</sup>
- Descent of Jesus into Lower World . . . . . 200<sup>a</sup>
- Gospel of Infancy . . . . 199<sup>a</sup>
- Gospel of Joseph . . . . . 199<sup>a</sup>
- Gospel of the Nativity . . . . . 198<sup>a</sup>

- Apocryphal Gospels—*continued*  
 Supplementary or legendary gospels—*continued*  
 Gospel of Nativity  
 of Mary . . . . . 198<sup>b</sup>  
 Gospel of Nicodemus 200<sup>a</sup>  
 Gospel of the Passion 200<sup>a</sup>  
 Gospel of Pseudo-  
 Matthew . . . . . 198<sup>b</sup>  
 Gospel of Thomas . . . 199<sup>a</sup>  
 Other fabrications . . 200<sup>a</sup>  
 Passing of Mary . . . 199<sup>a</sup>  
 Protevangelium of  
 James . . . . . 198<sup>a</sup>  
 of Thomas . . . . . 2973<sup>a</sup> (Kerr)  
 Apollonia . . . . . 200<sup>b</sup> (Tod)  
 Apollonius . . . . . 200<sup>b</sup> (Hutchison)  
 of Gennaues . . . . . 1214<sup>b</sup>  
 of Menestheus . . . . . 2033<sup>a</sup>  
 of Thrasaeus . . . . . 2975<sup>b</sup>  
 Apollophanes . . . . . 201<sup>a</sup>  
 Apollos . . . . . 201<sup>a</sup> (Kerr)  
 of Ep. to Hebrews . . . 1358<sup>b</sup>  
 of Pastoral Epistles . . 2260<sup>a</sup> (Rutherford)  
 Apollyon . . . . . 201<sup>b</sup> (Sweet); 2<sup>b</sup> (Beecher)  
 NT usage . . . . . 201<sup>b</sup>  
 OT background . . . . . 201<sup>b</sup>  
 Apostasy, Apostate . . . 202<sup>b</sup> (Pratt)  
 of Idolatry . . . . . 1447<sup>b</sup> (Cobern)  
 Apostles . . . . . 202<sup>b</sup> (Lambert)  
 Apostles in Didache . . 203<sup>b</sup>  
 Apostleship, the . . . . . 203<sup>b</sup>  
 Call of apostles . . . . 1636<sup>b</sup> (Orr)  
 of Jesus Christ . . . . . 1642<sup>a</sup> (Orr)  
 Paul . . . . . 203<sup>a</sup>  
 of Spiritual Gifts . . . 2843<sup>a</sup> (Lambert)  
 Twelve, the . . . . . 202<sup>b</sup>  
 Wider circle of . . . . . 203<sup>a</sup>  
 Apostles' Creed . . . . . 204<sup>b</sup> (Orr); 742<sup>b</sup> (Alexander)  
 Form . . . . . 204<sup>a</sup>  
 History . . . . . 205<sup>a</sup>  
 Modern controversies . 206<sup>a</sup>  
 Origin . . . . . 205<sup>a</sup>  
 Structure . . . . . 205<sup>b</sup>  
 of Virgin-birth . . . . . 3057<sup>a</sup> (Sweet)  
 Apostles, Gospel of the  
 Twelve  
 of Apocryphal Gospels 195<sup>a</sup> (Hutchison)  
 Apostolic Age . . . . . 206<sup>a</sup> (Easton)  
 Hellenism . . . . . 207<sup>a</sup>  
 Jerusalem church . . . 206<sup>b</sup>  
 Judaists . . . . . 207<sup>a</sup>  
 Mission . . . . . 206<sup>b</sup>  
 NT canon . . . . . 563<sup>a</sup> (Riggs)  
 Relations with Rome . . 207<sup>a</sup>  
 Spiritual gifts . . . . . 2843<sup>a</sup> (Lambert)  
 Apostolic Church Ordina-  
 nances  
 of Didache . . . . . 387<sup>b</sup> (A. T. Robertson)  
 Apostolic Constitutions  
 of Didache . . . . . 387<sup>b</sup> (A. T. Robertson)  
 Apostolic Council . . . . 207<sup>b</sup>  
 Apostolic Fathers . . . . 207<sup>b</sup>  
 Epistles of  
 of Literature, Sub-  
 apos . . . . . 1896<sup>b</sup> (Cowan)  
 Apothecary . . . . . 207<sup>b</sup>  
 of Perfumer . . . . . 2321<sup>b</sup> (Patch)  
 Appaim . . . . . 207<sup>b</sup>  
 Apparel . . . . . 207<sup>b</sup> (Pratt)  
 Apparently . . . . . 207<sup>b</sup>  
 Apparition . . . . . 207<sup>b</sup>  
 Appeal . . . . . 208<sup>a</sup> (Jacobs)  
 Appear . . . . . 208<sup>a</sup> (Pratt)  
 Appearance . . . . . 208<sup>b</sup>  
 Appearing . . . . . 208<sup>b</sup>  
 Appease . . . . . 208<sup>b</sup>  
 Appertain . . . . . 208<sup>b</sup>  
 Appetite . . . . . 208<sup>b</sup> (S. F. Hunter)  
 Apphia . . . . . 208<sup>b</sup>  
 Apphus . . . . . 209<sup>a</sup> (Wolf)  
 Appii Forum . . . . . 209<sup>a</sup> (Allen)  
 of Market . . . . . 1995<sup>b</sup> (Raffety)  
 Apple, Apple-tree . . . . 209<sup>a</sup> (Masterman); 1123<sup>a</sup>  
 (Eager)  
 of Beth-tappuah . . . . 453<sup>b</sup> (Masterman)  
 of Tappuah . . . . . 2909<sup>a</sup> (Ewing)  
 Apple of the Eye . . . . 209<sup>b</sup> (W. L. Walker)  
 Apples of Sodom . . . . . 210<sup>a</sup> (W. L. Walker)  
 Apply . . . . . 210<sup>a</sup>  
 Appoint . . . . . 210<sup>a</sup> (Hirsch)  
 Apprehend . . . . . 210<sup>b</sup>  
 of Comprehend . . . . . 695<sup>b</sup> (Pratt)  
 Approve . . . . . 210<sup>b</sup> (Jacobs)  
 Apron . . . . . 210<sup>b</sup> (Eager)  
 Apt . . . . . 210<sup>b</sup>  
 Aqueducts . . . . . 659<sup>a</sup> (A. C. Dickie)  
 of Jericho . . . . . 1592<sup>b</sup> (Wright)  
 Aquila . . . . . 211<sup>a</sup> (Kapp)  
 And Priscilla  
 of Ep. to Hebrews . . . 1358<sup>a</sup> (Rees)  
 of Septuagint . . . . . 2725<sup>b</sup> (Thackeray)  
 Ar, Ar of Moab . . . . . 211<sup>a</sup> (Ewing)  
 of Gad, Valley of . . . . 1152<sup>b</sup> (Ewing)  
 Ara . . . . . 211<sup>b</sup>  
 Arab, Arabians (Arabia) 213<sup>b</sup> (Weir)  
 Arabah . . . . . 211<sup>b</sup> (Wright)  
 Geology of region . . . . 212<sup>a</sup>  
 of Gomorrah . . . . . 1277<sup>a</sup> (Wright)  
 History . . . . . 213<sup>b</sup>  
 of Jordan . . . . . 1732<sup>b</sup> (Wright)  
 of Jordan Valley . . . . 1735<sup>a</sup> (Wright)  
 of Lebanon . . . . . 1863<sup>a</sup> (Wright)  
 of Plain . . . . . 2406<sup>b</sup> (Day)  
 of Siddim . . . . . 2784<sup>a</sup> (Wright)  
 of Sodom . . . . . 2821<sup>b</sup> (Wright)  
 of Wanderings of Israel 3065<sup>a</sup> (Conder)  
 Arabattine (Akrahattine) 89<sup>a</sup>  
 Arabia . . . . . 213<sup>b</sup> (Weir)  
 Flora and fauna . . . . . 216<sup>b</sup>  
 Inhabitants . . . . . 217<sup>a</sup>  
 Name and situation . . . 214<sup>a</sup>  
 Physical features . . . . . 214<sup>b</sup>  
 Political divisions . . . . 215<sup>b</sup>  
 Religion . . . . . 218<sup>b</sup>

- Arabian  
   cf Arabia . . . . . 213<sup>b</sup> (Weir)
- Arabic Gospel of the  
   Infancy  
   cf Apocryphal Gospels 195<sup>a</sup> (Hutchison)
- Arabic History of Joseph  
   the Carpenter  
   cf Apocryphal Gos-  
   pels . . . . . 195<sup>a</sup> (Hutchison)
- Arabic Language . . . . . 220<sup>a</sup> (Boyd)
- Arabic Versions . . . . . 221<sup>a</sup> (Weir)
- Arad . . . . . 221<sup>b</sup> (Beecher)
- Aradus . . . . . 221<sup>b</sup>
- Arah . . . . . 221<sup>b</sup>
- Aram . . . . . 222<sup>a</sup>  
   cf Paddan-aram . . . . . 2206<sup>b</sup> (Christie)  
   cf Syria . . . . . 2880<sup>b</sup> (Christie)
- Aramaeans, Arameans . . . . . 222<sup>a</sup>
- Aramaic  
   cf Laban . . . . . 1819<sup>a</sup> (Boyd)  
   cf Languages of OT . . . . . 1835<sup>b</sup> (Weir)  
   cf Seveneh . . . . . 2744<sup>a</sup>  
   cf Syriac . . . . . 2883<sup>a</sup>
- Aramaic Language . . . . . 222<sup>a</sup> (J. E. H. Thomson)  
   Biblical evidences . . . . . 222<sup>a</sup>  
   Comparison of Biblical  
   with Assouan Ara-  
   maic . . . . . 223<sup>b</sup>  
   Comparison of Biblical  
   with Sinjirli Ara-  
   maic . . . . . 223<sup>a</sup>  
   Dialects, Aramaic . . . . . 222<sup>b</sup>  
   Early Scriptural no-  
   tices . . . . . 222<sup>a</sup>  
   Elephantine papyri . . . . . 224<sup>a</sup>  
   Grammatical construc-  
   tions . . . . . 223<sup>a</sup>  
   cf Language of NT . . . . . 1826<sup>b</sup> (A. T. Robertson)  
   cf Languages of OT . . . . . 1832<sup>a</sup> (Weir)  
   Script, Aramaic . . . . . 222<sup>b</sup>  
   cf Syriac . . . . . 2883<sup>a</sup>
- Aramaic Versions  
   cf Targums . . . . . 2910<sup>a</sup> (J. E. H. Thomson)
- Aram-dammesek . . . . . 224<sup>b</sup>  
   cf Syria . . . . . 2880<sup>b</sup> (Christie)
- Aramitess . . . . . 224<sup>b</sup>
- Aram-maacah  
   cf Syria . . . . . 2880<sup>b</sup> (Christie)
- Aram-uaharaim  
   cf Syria . . . . . 2880<sup>b</sup> (Christie)
- Aram-rehob  
   cf Syria . . . . . 2880<sup>b</sup> (Christie)
- Aram-zobah  
   cf Syria . . . . . 2880<sup>b</sup> (Christie)
- Aran . . . . . 224<sup>b</sup> (Cohon)
- Ararat (Ararah, Ararath) 224<sup>b</sup> (Wright)
- Arathes . . . . . 225<sup>b</sup> (Harry)
- Araunah, the Jebusite . . . . . 225<sup>b</sup>  
   cf Jerusalem . . . . . 1601<sup>a</sup> (Masterman)
- Arba . . . . . 225<sup>b</sup>  
   Arba, City of  
     cf Hebron . . . . . 1365<sup>a</sup> (Masterman)
- Arbathite . . . . . 225<sup>b</sup>
- Arbatta . . . . . 225<sup>b</sup> (Ewing)
- Arbela . . . . . 225<sup>b</sup> (Ewing)  
   cf Beth-arbel . . . . . 443<sup>a</sup> (Ewing)
- Arbite . . . . . 226<sup>a</sup>
- Arbonai . . . . . 226<sup>a</sup>
- Arch . . . . . 226<sup>a</sup>
- Archaeology  
   cf Inscription . . . . . 1473<sup>a</sup>
- Archaeology of Asia  
   Minor . . . . . 277<sup>a</sup> (White)  
   Byzantine period . . . . . 281<sup>b</sup>  
   Early influences from  
     Mesopotamia . . . . . 277<sup>a</sup>  
   First millennium BC . . . . . 280<sup>a</sup>  
   Hittite art, second mil-  
   lennium BC . . . . . 278<sup>a</sup>  
     cf Hittites . . . . . 1395<sup>b</sup> (Conder)  
   Romans in Asia Minor 281<sup>a</sup>  
     cf Pontus . . . . . 2418<sup>a</sup> (White)  
   Seljukian Turks . . . . . 282<sup>a</sup>  
   Tablets of third mil-  
   lennium BC . . . . . 277<sup>b</sup>
- Archaeology and Criti-  
   cism . . . . . 226<sup>a</sup> (Kyle)  
   Function . . . . . 226<sup>b</sup>  
   History . . . . . 229<sup>a</sup>  
   cf Table of Nations . . . . . 2898<sup>b</sup> (Pinches)  
   cf Tell el-Amarna . . . . . 2927<sup>a</sup> (Kyle)
- Archangel (Angel) . . . . . 132<sup>b</sup> (J. M. Wilson)
- Archelaus . . . . . 233<sup>b</sup>  
   cf Herod . . . . . 1378<sup>b</sup> (Dosker)
- Archery . . . . . 233<sup>b</sup> (Eager)  
   cf Shaft . . . . . 2746<sup>b</sup>
- Archevite . . . . . 233<sup>b</sup>
- Archi (Archites) . . . . . 238<sup>b</sup> (Wolf)
- Archippus . . . . . 233<sup>b</sup>
- Architecture . . . . . 234<sup>a</sup> (A. C. Dickie)  
   cf Building . . . . . 527<sup>a</sup> (A. C. Dickie)  
   cf City . . . . . 662<sup>a</sup> (A. C. Dickie)  
   Estimates . . . . . 234<sup>a</sup>  
   cf Fortification . . . . . 1136<sup>b</sup> (Nicol)  
   Herodian work . . . . . 238<sup>a</sup>  
   cf House . . . . . 1434<sup>b</sup> (A. C. Dickie)  
   Of Jews . . . . . 234<sup>b</sup>  
   Maccabean work . . . . . 237<sup>b</sup>  
   cf Mason . . . . . 2007<sup>a</sup>  
   Painted tombs at Ma-  
   rissa . . . . . 237<sup>b</sup>  
   Plans . . . . . 234<sup>a</sup>  
   Solomon's temple and  
   palace . . . . . 234<sup>b</sup>  
   Synagogues . . . . . 238<sup>a</sup>  
   Temple of Onias . . . . . 237<sup>a</sup>  
   cf Temple . . . . . 2930<sup>a</sup> (Caldecott; Orr)
- Archites . . . . . 238<sup>b</sup> (Wolf)  
   cf Ataroth . . . . . 317<sup>a</sup> (Ewing)
- Archives . . . . . 238<sup>b</sup>
- Arcturus . . . . . 238<sup>b</sup>  
   cf Astronomy . . . . . 300<sup>b</sup> (Maunder)



- Aroturus (Great Bear) . . . 313<sup>a</sup>  
 Ard . . . . . 238<sup>b</sup>  
   cf Addar . . . . . 55<sup>a</sup>  
 Ardat . . . . . 238<sup>b</sup>  
 Ardites (Ard) . . . . . 238<sup>b</sup>  
 Ardon . . . . . 238<sup>b</sup>  
 Areli . . . . . 238<sup>b</sup>  
 Arelites (Arelī) . . . . . 238<sup>b</sup>  
 Areopagite  
   cf Dionysius . . . . . 850<sup>a</sup> (Harry)  
 Areopagus . . . . . 238<sup>b</sup> (Harry)  
 Areopolis . . . . . 239<sup>b</sup>  
 Ares . . . . . 239<sup>b</sup>  
 Aretas . . . . . 240<sup>a</sup> (Dosker)  
 Argob . . . . . 240<sup>a</sup> (Wolf); 240<sup>b</sup> (Ewing)  
   cf Og . . . . . 2180<sup>b</sup> (Orr)  
   cf Trachonitis . . . . . 3001<sup>b</sup> (Ewing)  
 Argue . . . . . 241<sup>a</sup>  
 Arianism . . . . . 627<sup>b</sup> (Orr)  
 Ariarathes (Arathes) . . . . . 225<sup>b</sup> (Harry)  
 Aridai . . . . . 241<sup>a</sup>  
 Aridatha . . . . . 241<sup>a</sup>  
 Arich (Argob) . . . . . 240<sup>a</sup> (Wolf)  
 Ariel . . . . . 241<sup>a</sup> (Beecher)  
   cf Iduel . . . . . 1448<sup>b</sup>  
   cf Jerusalem . . . . . 1596<sup>b</sup> (Masterman)  
 Aright . . . . . 241<sup>a</sup>  
 Arimathaea . . . . . 241<sup>a</sup> (S. F. Hunter)  
 Arioeh . . . . . 241<sup>a</sup> (Pinches)  
   cf Hammurabi . . . . . 1326<sup>a</sup> (Pinches)  
   cf Tidal . . . . . 2980<sup>a</sup> (Pinches)  
 Arisai . . . . . 241<sup>b</sup>  
 Aristarchus . . . . . 241<sup>b</sup> (S. F. Hunter)  
 Aristeas  
   cf Septuagint . . . . . 2723<sup>a</sup> (Thackeray)  
 Aristobulus . . . . . 241<sup>b</sup> (M. O. Evans)  
   cf Asmoneans . . . . . 283<sup>a</sup> (Dosker)  
   cf Hyrcanus . . . . . 1445<sup>b</sup>  
   cf Maccabaeus . . . . . 1946<sup>a</sup> (Hutchison)  
 Aristotle . . . . . 1017<sup>b</sup> (Alexander)  
   cf Logos . . . . . 1912<sup>b</sup> (Alexander)  
 Arithmetic  
   cf Number . . . . . 2157<sup>b</sup> (Smith)  
 Arius . . . . . 242<sup>a</sup>  
   cf Lacedaemonians . . . . . 1819<sup>b</sup> (Hutchison)  
   cf Oniaries . . . . . 2195<sup>b</sup>  
   cf Sparta . . . . . 2839<sup>b</sup> (Orr)  
 Ark  
   cf Libraries . . . . . 1883<sup>b</sup> (Richardson)  
 Ark of Bulrushes . . . . . 242<sup>a</sup> (Kyle)  
   cf Moses . . . . . 2084<sup>a</sup> (Kyle)  
 Ark of the Covenant . . . . . 242<sup>b</sup> (Lotz); 12<sup>a</sup> (Beecher)  
   Contents of . . . . . 244<sup>a</sup>  
   Form of . . . . . 243<sup>b</sup>  
   History of . . . . . 245<sup>a</sup>  
   cf Holy of Holies . . . . . 1405<sup>a</sup> (Caldecott)  
   At Kiriath-jearim . . . . . 1812<sup>b</sup> (Masterman)  
   cf Mercy-seat, The . . . . . 2036<sup>a</sup> (Caldecott)  
   Names of . . . . . 244<sup>b</sup>  
   Pentateuch . . . . . 242<sup>b</sup>  
   Removal by David . . . . . 794<sup>a</sup> (Weir)  
   Significance of . . . . . 245<sup>a</sup>  
 Ark of the Covenant—*continued*  
   cf Tabernacle . . . . . 2890<sup>b</sup>; 2892<sup>b</sup> (Caldecott;  
     Orr)  
   cf Temple . . . . . 2933<sup>b</sup> (Caldecott; Orr)  
 Ark of Noah . . . . . 246<sup>a</sup> (Wright)  
   cf Deluge . . . . . 821<sup>b</sup> (Wright)  
   cf Noah . . . . . 2153<sup>a</sup> (Wright)  
 Ark of Testimony  
   cf Ark of the Covenant . . . . . 242<sup>b</sup> (Lotz)  
 Arkite . . . . . 246<sup>b</sup> (Porter)  
 Arm . . . . . 246<sup>b</sup> (S. F. Hunter)  
 Armageddon . . . . . 246<sup>b</sup>  
   cf Megiddo . . . . . 2027<sup>b</sup> (Ewing)  
 Armenia . . . . . 246<sup>b</sup> (Tisdall)  
   Aryan . . . . . 248<sup>b</sup>  
   cf Togarmah . . . . . 2993<sup>b</sup> (Pinches)  
   Turanian . . . . . 247<sup>b</sup>  
 Armenian Language . . . . . 250<sup>b</sup> (Tisdall)  
 Armenian Religion . . . . . 249<sup>a</sup> (Tisdall)  
 Armenian Versions of  
   Bible . . . . . 249<sup>b</sup> (Tisdall)  
   Ancient . . . . . 249<sup>b</sup>  
   Modern . . . . . 250<sup>b</sup>  
   cf Versions, Georgian . . . . . 3048<sup>a</sup> (Easton)  
 Armhole . . . . . 250<sup>b</sup> (W. W. Davies)  
 Armlet . . . . . 250<sup>b</sup> (Eager)  
 Armoni . . . . . 251<sup>a</sup>  
   cf Mephibosheth . . . . . 2033<sup>b</sup> (Wallace)  
 Armor, Arms . . . . . 251<sup>a</sup> (Nicol)  
   Dart . . . . . 789<sup>b</sup>  
   Defensive weapons . . . . . 252<sup>b</sup>  
   cf Gorget . . . . . 1279<sup>b</sup> (Nicol)  
   cf Habergeon . . . . . 1313<sup>a</sup>  
   In NT . . . . . 251<sup>a</sup>  
   In OT . . . . . 251<sup>a</sup>  
   Offensive weapons . . . . . 251<sup>b</sup>  
   cf Rod . . . . . 2596<sup>b</sup> (Orr)  
   cf Shaft . . . . . 2746<sup>b</sup>  
 Armor-bearer . . . . . 254<sup>a</sup> (Nicol)  
 Armory . . . . . 254<sup>b</sup> (Nicol)  
 Army . . . . . 254<sup>b</sup> (Nicol); 251<sup>a</sup> (Nicol)  
   Early monarchy of  
     Israel . . . . . 255<sup>a</sup>  
   In the field . . . . . 256<sup>b</sup>  
   First campaign of his-  
     tory . . . . . 254<sup>b</sup>  
   Israelites in wilder-  
     ness . . . . . 254<sup>b</sup>  
   Israelitish tribes after  
     conquest . . . . . 255<sup>a</sup>  
   In NT . . . . . 257<sup>a</sup>  
   Organization of He-  
     brew army . . . . . 256<sup>a</sup>  
   cf Rank . . . . . 2530<sup>a</sup>  
   cf Rearward . . . . . 2534<sup>b</sup>  
   From Solomon onward . . . . . 256<sup>a</sup>  
   cf War . . . . . 3069<sup>b</sup> (Nicol)  
 Army, Roman . . . . . 257<sup>a</sup> (Allen); 382<sup>b</sup> (Nicol)  
   Allusions in NT . . . . . 258<sup>a</sup>  
   cf Julius . . . . . 1780<sup>b</sup>  
   Organization . . . . . 257<sup>a</sup>  
 Arna . . . . . 258<sup>b</sup>

- Arnan . . . . . 258<sup>b</sup>  
 Arni . . . . . 258<sup>b</sup>  
 Arnon . . . . . 259<sup>a</sup> (Ewing)  
 Arod, Arodi, Arodites . . . . . 259<sup>a</sup>  
 Aroer . . . . . 259<sup>a</sup> (Ewing)  
 Aroerite . . . . . 259<sup>b</sup>  
 Arom . . . . . 259<sup>b</sup>  
 Arpachshad (Arphaxad) . . . . . 259<sup>b</sup>  
   cf Semites . . . . . 2717<sup>a</sup> (Mack)  
 Arpad . . . . . 259<sup>b</sup> (S. F. Hunter)  
 Arphaxad . . . . . 259<sup>b</sup>  
 Array . . . . . 259<sup>b</sup> (S. F. Hunter)  
 Arrest and Trial of Jesus  
   Christ . . . . . 1668<sup>b</sup> (Maclaren)  
 Arrive . . . . . 259<sup>b</sup>  
 Arrogancy . . . . . 260<sup>a</sup>  
 Arrow  
   cf Archery . . . . . 233<sup>b</sup> (Eager)  
   cf Armor . . . . . 251<sup>a</sup> (Nicol)  
 Arrows, Divination by . . . . . 331<sup>b</sup>  
 Arrowsnake . . . . . 260<sup>a</sup>  
   cf Owl . . . . . 2205<sup>b</sup> (Stratton-Porter)  
   cf Serpent . . . . . 2736<sup>a</sup> (Day)  
 Arsaces . . . . . 260<sup>a</sup> (R. D. Wilson)  
 Arsareth (Arzareth) . . . . . 261<sup>b</sup>  
 Arsiphurith . . . . . 260<sup>a</sup>  
 Artaxerxes . . . . . 260<sup>a</sup> (R. D. Wilson)  
 Artemas . . . . . 260<sup>b</sup>  
 Artemis  
   cf Diana . . . . . 842<sup>b</sup> (Banks)  
 Artificer  
   cf Crafts . . . . . 734<sup>a</sup> (Patch)  
 Artillery . . . . . 261<sup>a</sup>  
 Artisan  
   cf Crafts . . . . . 734<sup>a</sup> (Patch)  
 Arts  
   cf Crafts . . . . . 734<sup>a</sup> (Patch)  
 Arubboth . . . . . 261<sup>a</sup>  
 Arumah . . . . . 261<sup>a</sup>  
 Arvad, Arvadites . . . . . 261<sup>a</sup> (Porter)  
   cf Aradus . . . . . 221<sup>b</sup>  
   cf Island . . . . . 1511<sup>a</sup> (Day)  
 Arza . . . . . 261<sup>b</sup>  
 Arzareth . . . . . 261<sup>b</sup>  
 As . . . . . 261<sup>b</sup>  
 Asa . . . . . 261<sup>b</sup> (W. W. Davies)  
 Asadiah . . . . . 262<sup>a</sup>  
   cf Hasadiah . . . . . 1342<sup>a</sup>  
 Asael (Asiel) . . . . . 282<sup>b</sup>  
 Asahel . . . . . 262<sup>a</sup> (Beecher)  
 Asahiah . . . . . 262<sup>b</sup>  
 Asaiah . . . . . 262<sup>b</sup> (W. W. Davies)  
 Asana . . . . . 262<sup>b</sup>  
 Asaph . . . . . 262<sup>b</sup> (Millar)  
   cf Music . . . . . 2094<sup>b</sup> (Millar)  
   cf Psalms, Book of . . . . . 2490<sup>b</sup> (Sampey)  
 Asara . . . . . 263<sup>a</sup>  
 Asaramel . . . . . 263<sup>a</sup> (Wolf)  
 Asareel, Asarel . . . . . 263<sup>a</sup>  
 Asarelah (Asharelah) . . . . . 267<sup>a</sup>  
 Asbasareth (Asbacaphath) . . . . . 263<sup>a</sup>  
   cf Ashurbanipal . . . . . 271<sup>b</sup>; 367<sup>b</sup> (Clay)  
 Ascalon . . . . . 263<sup>a</sup>  
   cf Ashkelon . . . . . 269<sup>b</sup> (Porter)  
 Ascend . . . . . 263<sup>a</sup> (Farr)  
 Ascension . . . . . 263<sup>b</sup> (Thomas); 615<sup>a</sup>  
   (Bevan)  
   In the Acts . . . . . 263<sup>b</sup>  
   In the Gospels . . . . . 263<sup>b</sup>  
   In the Hebrews . . . . . 264<sup>a</sup>  
   Of Isaiah . . . . . 170<sup>b</sup> (J. E. H. Thomson)  
   of Jesus Christ . . . . . 1666<sup>b</sup> (Orr)  
   In Johannine writings . . . . . 264<sup>b</sup>  
   NT teachings . . . . . 264<sup>b</sup>  
   In Pauline Epistles . . . . . 264<sup>a</sup>  
   In Petrine Epistles . . . . . 264<sup>a</sup>  
   Problems . . . . . 265<sup>a</sup>  
   Relation to Christ . . . . . 265<sup>a</sup>  
   Teaching for Chris-  
     tians . . . . . 265<sup>a</sup>  
 Ascent . . . . . 266<sup>b</sup> (Farr)  
 Ascetics  
   cf Abstinence . . . . . 25<sup>a</sup> (Eager)  
 Aschenaz (Ashkenaz) . . . . . 269<sup>b</sup>  
 Aseas . . . . . 266<sup>b</sup>  
   cf Isshijah . . . . . 1542<sup>b</sup>  
 Asebebias . . . . . 266<sup>b</sup>  
   cf Sarabias (Apoc) . . . . . 2690<sup>b</sup>  
   cf Sherebiah . . . . . 2764<sup>b</sup> (Wolf)  
 Asebias . . . . . 266<sup>b</sup>  
 Asenath . . . . . 266<sup>b</sup> (Boyd)  
 Aser . . . . . 266<sup>b</sup>  
 Aserer (Serar) . . . . . 2732<sup>b</sup>  
 Ash . . . . . 266<sup>b</sup> (Masterman)  
 Ash (Bear)  
   cf Astronomy . . . . . 300<sup>b</sup> (Maunder)  
 Ashamed . . . . . 267<sup>a</sup> (Pratt)  
   cf Shame . . . . . 2748<sup>a</sup> (Stuart)  
 Ashan . . . . . 267<sup>a</sup>  
 Asharelah . . . . . 267<sup>a</sup>  
 Ashbea . . . . . 267<sup>b</sup>  
 Ashbel, Ashbelite . . . . . 267<sup>b</sup> (Wolf)  
 Ashdod . . . . . 267<sup>b</sup> (Porter)  
 Ashdodites . . . . . 267<sup>b</sup>  
 Ashdoth Pisgah . . . . . 268<sup>a</sup>  
   cf Pisgah . . . . . 2400<sup>a</sup> (Ewing)  
 Asher . . . . . 268<sup>a</sup> (Ewing)  
   cf Galilee . . . . . 1163<sup>a</sup> (Ewing)  
   cf Hazor . . . . . 1347<sup>b</sup> (Ewing)  
 Asherah . . . . . 268<sup>b</sup> (Sayce)  
   cf Gezer . . . . . 1223<sup>b</sup> (Masterman)  
   cf God . . . . . 1256<sup>a</sup> (Rees)  
   cf Gods . . . . . 1271<sup>a</sup> (Reeve)  
   cf High Place . . . . . 1390<sup>a</sup> (Easton)  
 Asherim  
   cf Semites . . . . . 2717<sup>a</sup> (Mack)  
 Asherites . . . . . 269<sup>a</sup>  
 Ashes . . . . . 269<sup>a</sup> (Eager)  
   cf Heifer, Red . . . . . 1367<sup>b</sup> (Easton)  
 Ashhur . . . . . 269<sup>b</sup> (Cohon)  
 Ashima . . . . . 269<sup>b</sup> (Sayce)  
   cf Gods . . . . . 1271<sup>a</sup> (Reeve)  
 Ashkelon . . . . . 269<sup>b</sup> (Porter)  
 Ashkelonites . . . . . 269<sup>b</sup>

- Ashkenaz . . . . . 269<sup>b</sup>  
   cf Table of Nations . . . 2898<sup>b</sup> (Pinches)  
 Ashnah . . . . . 270<sup>a</sup> (Masterman)  
 Ashpenaz . . . . . 270<sup>a</sup> (R. D. Wilson)  
 Ashriel (Asriel) . . . . . 287<sup>a</sup>  
 Ashtaroth, Ashteroth-  
   karnaim, Beesh-  
   terah . . . . . 270<sup>a</sup> (Ewing)  
   cf Ashtoreth . . . . . 270<sup>b</sup> (Sayce)  
   cf Philistines . . . . . 2377<sup>a</sup> (Conder)  
 Ashterathite . . . . . 270<sup>b</sup>  
 Ashteroth-karnaim . . . . . 270<sup>b</sup>; 270<sup>a</sup> (Ewing)  
 Ashtoreth . . . . . 270<sup>b</sup> (Sayce); 270<sup>a</sup> (Ewing)  
   cf Gods . . . . . 1271<sup>a</sup> (Reeve)  
   cf Harlot . . . . . 1339<sup>b</sup> (Eager)  
   cf Palestine, Recent  
     Exploration . . . . . 2233<sup>a</sup> (Cobern)  
   cf Phoenicia . . . . . 2386<sup>a</sup> (Porter); 2389<sup>b</sup>  
     (Porter)  
   cf Semites . . . . . 2717<sup>a</sup> (Mack)  
 Ashur (Ashhur) . . . . . 269<sup>b</sup> (Cohon)  
 Ashurbanipal . . . . . 271<sup>b</sup> (Clay); 367<sup>b</sup> (Clay)  
 Ashurites . . . . . 272<sup>a</sup>  
 Ashvath . . . . . 272<sup>a</sup>  
 Asia . . . . . 272<sup>b</sup> (Banks)  
   cf Lydia . . . . . 1943<sup>a</sup> (Banks)  
 Asia Minor . . . . . 272<sup>b</sup> (Calder)  
   Christianity in . . . . . 276<sup>b</sup>  
   Country . . . . . 273<sup>a</sup>  
   First century AD . . . . . 275<sup>b</sup>  
   History . . . . . 274<sup>a</sup>  
 Asia Minor, Archaeology  
   of . . . . . 277<sup>a</sup> (White)  
   Byzantine period . . . . . 281<sup>b</sup>  
   Early influences from  
     Mesopotamia . . . . . 277<sup>a</sup>  
   First millennium BC . . . . . 280<sup>a</sup>  
   cf Hittites . . . . . 1395<sup>b</sup> (Conder)  
   Romans in Asia Minor 281<sup>a</sup>  
   cf Pontus . . . . . 2418<sup>a</sup> (White)  
   Seljukian Turks . . . . . 282<sup>a</sup>  
   Tablets of third mil-  
     lennium BC . . . . . 277<sup>b</sup>  
 Asiarch . . . . . 282<sup>a</sup> (M. O. Evans)  
 Asibias . . . . . 282<sup>a</sup>  
 Aside . . . . . 282<sup>a</sup>  
 Asiel . . . . . 282<sup>b</sup>  
 Asipha . . . . . 282<sup>b</sup>; 1343<sup>a</sup>  
 Ask . . . . . 282<sup>b</sup> (Kapp)  
   cf Amiss . . . . . 116<sup>b</sup>  
   cf Prayer . . . . . 2430<sup>b</sup> (Lambert)  
 Askelon . . . . . 282<sup>b</sup>  
 Asleep . . . . . 282<sup>b</sup> (Pratt)  
 Asmodaeus . . . . . 283<sup>a</sup> (Hutchison)  
 Asmoneans . . . . . 283<sup>a</sup> (Dosker)  
   cf Aristobulus . . . . . 242<sup>a</sup> (M. O. Evans)  
   Decadence of Macca-  
     bean House . . . . . 285<sup>b</sup>  
   cf Government . . . . . 1289<sup>a</sup> (Heidel)  
   cf Greece, Sons of . . . . . 1305<sup>a</sup>  
   cf Hasmoneans . . . . . 1527<sup>b</sup> (Weir)  
   cf John . . . . . 1706<sup>b</sup> (Hutchison)
- Asmoneans—*continued*  
   John Hyrcanus . . . . . 285<sup>a</sup>  
   Jonathan . . . . . 284<sup>b</sup>  
   Judas Maccabaeus . . . . . 283<sup>b</sup>  
     cf Maccabaeus . . . . . 1946<sup>a</sup> (Hutchison); 1947<sup>b</sup>  
       (T. W. Davies)  
   Mattathias . . . . . 283<sup>b</sup>  
     cf Mattathias . . . . . 2008<sup>b</sup> (Angus)  
   cf Palestine . . . . . 2220<sup>b</sup> (Conder)  
   cf Pharisees . . . . . 2361<sup>a</sup> (J. E. H. Thomson)  
   Simon . . . . . 285<sup>a</sup>  
 Asnah . . . . . 286<sup>b</sup>  
 Asnapper (Ashurbanipal) 271<sup>b</sup>; 367<sup>b</sup> (Clay)  
 Asochis, Plain of  
   cf Cana of Galilee . . . . . 548<sup>b</sup> (Ewing)  
 Asom . . . . . 286<sup>b</sup>  
 Asp . . . . . 286<sup>b</sup> (Day)  
   cf Adder . . . . . 55<sup>a</sup> (Day)  
 Aspalathus . . . . . 286<sup>b</sup>  
 Aspatha . . . . . 286<sup>b</sup>  
 Asphalt  
   cf Slime . . . . . 2817<sup>b</sup> (Day)  
 Asphar, The Pool . . . . . 286<sup>b</sup> (Ewing)  
 Aspharasus . . . . . 286<sup>b</sup>  
 Asriel . . . . . 287<sup>a</sup>  
 Ass . . . . . 287<sup>a</sup> (Cohon)  
   cf Horse . . . . . 1423<sup>a</sup> (Day)  
 Assalimoth (Salimoth) . . . . . 2663<sup>b</sup>  
 Assamias . . . . . 288<sup>a</sup>  
 Assaphioth . . . . . 288<sup>a</sup>  
 Assarion  
   cf Farthing . . . . . 1098<sup>b</sup>  
 Assassination . . . . . 288<sup>a</sup> (Hirsch)  
   cf Crimes . . . . . 746<sup>a</sup> (Hirsch)  
 Assassins . . . . . 288<sup>a</sup> (S. F. Hunter)  
   cf Felix Antonius . . . . . 1105<sup>b</sup> (Kerr)  
   cf Murderers . . . . . 2094<sup>a</sup> (Nicol)  
   cf Thief . . . . . 2972<sup>a</sup> (Easton)  
   cf Zealot . . . . . 3133<sup>b</sup> (Heidel)  
 Assault . . . . . 288<sup>b</sup>  
 Assay . . . . . 288<sup>b</sup> (Nicol)  
 Assemblies, Masters of . . . . . 288<sup>b</sup> (S. F. Hunter)  
   cf Asuppim . . . . . 316<sup>b</sup>  
   cf Master . . . . . 2007<sup>b</sup> (W. L. Walker)  
 Assembly . . . . . 289<sup>a</sup> (Kapp)  
   cf Church . . . . . 650<sup>b</sup> (Lambert)  
   cf Congregation . . . . . 700<sup>b</sup> (Wiener)  
 Assembly, Solemn  
   cf Congregation . . . . . 700<sup>b</sup> (Wiener)  
   cf Feasts and Fasts . . . . . 1103<sup>a</sup> (E. D. Isaacs)  
 Assent . . . . . 289<sup>a</sup>  
 Assessor . . . . . 289<sup>a</sup> (Eager)  
   cf Tax, Taxing . . . . . 2918<sup>a</sup> (Sweet)  
 Asseurus . . . . . 80<sup>b</sup> (R. D. Wilson)  
 Asshur, Assur  
   cf Assyria . . . . . 290<sup>b</sup> (Sayce)  
 Asshurim . . . . . 289<sup>b</sup>  
 Assideans  
   cf Hasidaeans . . . . . 1342<sup>b</sup> (Hutchison)  
 Assiduous . . . . . 289<sup>b</sup>  
 Assign . . . . . 289<sup>b</sup>  
 Assir . . . . . 289<sup>b</sup>

- Associate . . . . . 289<sup>b</sup>  
 Assos . . . . . 289<sup>b</sup> (Banks)  
 Assuage . . . . . 290<sup>a</sup>  
 Assumption of Moses . . . 161<sup>b</sup> (J. E. H. Thomson)  
 Assur  
   of Asur . . . . . 316<sup>b</sup>  
 Assurance . . . . . 290<sup>a</sup> (Pratt)  
 Assurbanipal  
   of Ashurbanipal . . . . 271<sup>b</sup> (Clay); 367<sup>b</sup> (Clay)  
 Assyria . . . . . 290<sup>b</sup> (Sayce)  
   Art . . . . . 291<sup>b</sup>  
   Chronology . . . . . 293<sup>a</sup>  
   Climate and pro-  
     ductions . . . . . 290<sup>b</sup>  
   Early history . . . . . 290<sup>b</sup>  
     of Amorites . . . . . 119<sup>a</sup> (Sayce)  
   Excavations . . . . . 293<sup>a</sup>  
     of Sherghat . . . . . 2764<sup>b</sup> (Banks)  
   Furniture, pottery and  
     embroidery . . . . . 292<sup>a</sup>  
   Geography . . . . . 290<sup>b</sup>  
   Government and army . . 292<sup>a</sup>  
   History . . . . . 293<sup>b</sup>  
     Ashurbanipal . . . . . 294<sup>b</sup>  
     Fall of empire . . . . . 294<sup>b</sup>  
     Older empire . . . . . 293<sup>b</sup>  
     Second empire . . . . . 294<sup>a</sup>  
     Tiglath-pileser . . . . . 294<sup>a</sup>  
   of Inscription . . . . . 1473<sup>a</sup>  
   Language, literature,  
     science . . . . . 292<sup>a</sup>  
     of Nineveh, Library  
       of . . . . . 2151<sup>a</sup> (Sayce)  
   Mechanics . . . . . 291<sup>b</sup>  
   of Menahem . . . . . 2031<sup>b</sup> (Caldecott)  
   of Pekah . . . . . 2295<sup>b</sup> (Caldecott)  
   of Phoenicia . . . . . 2390<sup>b</sup> (Porter)  
   Population . . . . . 291<sup>a</sup>  
   of Rab-saris . . . . . 2522<sup>b</sup> (Clippinger)  
   Religion . . . . . 292<sup>b</sup>  
     of Babylonia . . . . . 353<sup>b</sup> (Clay)  
     of Babylonia, Re-  
       ligion of . . . . . 368<sup>b</sup> (Rogers)  
   of Semites . . . . . 2717<sup>a</sup> (Mack)  
   of Shalmaneser . . . . . 2747<sup>b</sup> (Nicol)  
   of Sherghat, or  
     Asshur . . . . . 2764<sup>b</sup> (Banks)  
   of Ships and Boats . . . . 2775<sup>b</sup> (Nicol)  
   Trade and Law . . . . . 291<sup>a</sup>  
     of Amraphel . . . . . 126<sup>a</sup> (Pinches)  
   of Tyre . . . . . 3031<sup>b</sup> (Porter)  
 Assyria and Babylonia,  
   Religion of . . . . . 368<sup>b</sup> (Rogers)  
 Assyrian and Babylonian  
   Libraries  
     of Nineveh, Library of . . 2151<sup>a</sup> (Sayce)  
 Assyrian Captivity . . . . . 2747<sup>b</sup> (Nicol)  
 Assyrians . . . . . 295<sup>a</sup>  
   of Israel, History of . . . 1522<sup>a</sup> (Orelli)  
 Astad . . . . . 295<sup>a</sup>  
   of Azgad . . . . . 344<sup>b</sup>  
   of Sadas . . . . . 2658<sup>a</sup>  
 Astaroth (Ashtaroth) . . . 270<sup>a</sup> (Ewing)  
 Astarte, Astoreth (Ash-  
   taroth) . . . . . 270<sup>a</sup> (Ewing)  
   of Images . . . . . 1452<sup>a</sup> (Cobern)  
 Astath . . . . . 295<sup>b</sup>  
   of Azgad . . . . . 344<sup>b</sup>  
 Astonished, Astonied . . . 295<sup>b</sup> (Pratt)  
 Astonishment . . . . . 295<sup>b</sup>  
 Astray . . . . . 295<sup>b</sup> (Pratt)  
 Astrologers . . . . . 297<sup>a</sup>  
 Astrology . . . . . 295<sup>b</sup> (Maunder); 860<sup>b</sup>  
   (T. W. Davies)  
   Astrologers . . . . . 297<sup>a</sup>  
   Chiun worship . . . . . 298<sup>a</sup>  
   Divination . . . . . 296<sup>b</sup>  
   of Familiar . . . . . 1094<sup>a</sup> (Pollard)  
   of Fortune . . . . . 1141<sup>a</sup>  
   of Gad, God of Good  
     Luck . . . . . 1152<sup>a</sup> (Stearns)  
   Gadh and Meni . . . . . 299<sup>a</sup>  
   of Golden Calf . . . . . 1275<sup>a</sup>  
   "Looking in the liver" . . 296<sup>b</sup>  
     of Liver . . . . . 1905<sup>b</sup> (Luering)  
   of Lucifer . . . . . 1934<sup>b</sup>  
   of Magi . . . . . 1962<sup>a</sup> (Tisdall)  
   Mazzaloth . . . . . 298<sup>b</sup>  
   of Meni . . . . . 2033<sup>a</sup>  
   of Moloch . . . . . 2075<sup>b</sup>  
   Monthly prognosti-  
     cators . . . . . 297<sup>b</sup>  
   of Moon . . . . . 2081<sup>a</sup> (Schenk)  
   of Rephan . . . . . 2560<sup>a</sup>  
   Saturn or Moloch wor-  
     ship . . . . . 298<sup>a</sup>  
     of Calf, Golden . . . . . 542<sup>b</sup> (Cobern)  
   Soothsaying . . . . . 296<sup>a</sup>  
   Stargazers . . . . . 297<sup>b</sup>  
   Systems of . . . . . 299<sup>a</sup>  
   of Week . . . . . 3078<sup>b</sup>  
   of Wise Men . . . . . 3096<sup>b</sup> (Easton)  
 Astronomy . . . . . 300<sup>b</sup> (Maunder)  
   of Abyss . . . . . 26<sup>b</sup> (T. Lewis)  
   Cherubim . . . . . 310<sup>b</sup>  
   Constellations . . . . . 309<sup>a</sup>  
   of Day-star . . . . . 800<sup>a</sup> (Maunder)  
   Destruction, city of . . . 302<sup>a</sup>  
   Eclipses . . . . . 303<sup>b</sup>; 310<sup>a</sup>  
   Falling stars . . . . . 308<sup>a</sup>  
   of Feasts, Seasons  
     for . . . . . 1104<sup>b</sup>  
   of Golden Number . . . . . 1275<sup>a</sup>  
   Great Bear . . . . . 313<sup>a</sup>  
   of Heavens, Phy-  
     sical . . . . . 1352<sup>b</sup>  
   of Host of Heaven . . . . . 1433<sup>b</sup> (Orr)  
   of Leviathan . . . . . 1868<sup>a</sup> (Day)  
   of Magi . . . . . 1962<sup>a</sup> (Tisdall)  
   of Mazzaroth . . . . . 2013<sup>a</sup>  
   of Merodach . . . . . 2036<sup>b</sup>  
   of Month . . . . . 2081<sup>a</sup> (Porter)  
   Moon . . . . . 303<sup>a</sup>  
     of Moon . . . . . 2081<sup>a</sup> (Schenk)

Astronomy—*continued*

- Morning stars . . . . . 308<sup>a</sup>  
 of Nimrod . . . . . 2147<sup>b</sup> (Mack)  
 of North . . . . . 2155<sup>a</sup> (Day)  
 Ordinances of the  
   heaven . . . . . 301<sup>a</sup>  
 Orion . . . . . 312<sup>a</sup>  
 Physiography . . . . . 314<sup>a</sup>  
 Pleiades . . . . . 311<sup>b</sup>  
 of Rahab . . . . . 2525<sup>b</sup> (N. Isaacs)  
 of Sabbaths . . . . . 2634<sup>b</sup>  
 of Sabbatical . . . . . 2634<sup>b</sup> (Baur)  
 Seasons . . . . . 304<sup>a</sup>  
   of Seasons . . . . . 2710<sup>b</sup> (Joy)  
 of Serpent, Crooked . . . . . 2738<sup>b</sup>  
 Signs of Zodiac . . . . . 312<sup>b</sup>  
 of South, Chambers  
   of . . . . . 2838<sup>b</sup>  
 Stars . . . . . 306<sup>b</sup>  
 Sun . . . . . 301<sup>b</sup>  
 of Time . . . . . 2982<sup>a</sup> (Porter)  
 of Tires, Round . . . . . 2986<sup>a</sup>  
 Wandering stars . . . . . 308<sup>b</sup>  
 of Week . . . . . 3078<sup>b</sup>  
 of Wormwood, The  
   Star . . . . . 3110<sup>a</sup> (Orr)  
   of Year . . . . . 3126<sup>a</sup>  
 Astyages . . . . . 316<sup>a</sup> (Harry)  
 Asunder . . . . . 316<sup>a</sup> (S. F. Hunter)  
 Asuppim . . . . . 316<sup>b</sup>  
 Asur . . . . . 316<sup>b</sup>  
 Asylum . . . . . 316<sup>b</sup> (Wiener)  
   of Homicide . . . . . 1418<sup>a</sup> (Levertoff)  
 Asyncritus . . . . . 317<sup>a</sup>  
 Atad (Abel-mizraim) . . . . . 6<sup>a</sup> (Beecher)  
 Atar . . . . . 317<sup>a</sup>  
 Atarah . . . . . 317<sup>a</sup>  
 Atargatis, Atergatis . . . . . 317<sup>a</sup> (Sayce)  
 Ataroth . . . . . 317<sup>a</sup> (Ewing)  
 Ater . . . . . 317<sup>b</sup>  
 Aterezaias . . . . . 317<sup>b</sup>  
 Ateta . . . . . 317<sup>b</sup>  
 Athach . . . . . 317<sup>b</sup>  
 Athaiah . . . . . 317<sup>b</sup>  
 Athaliah . . . . . 317<sup>b</sup> (Caldecott)  
   of Jehoash . . . . . 1575<sup>b</sup> (Caldecott)  
   of Jehoiada . . . . . 1578<sup>a</sup> (Roberts)  
   of Judah, Kgd. of . . . . . 1760<sup>a</sup> (Weir)  
 Athanasian Creed . . . . . 743<sup>a</sup> (Alexander)  
 Atharias  
   of Tirshatha . . . . . 2986<sup>b</sup> (R. D. Wilson)  
 Atharim . . . . . 318<sup>b</sup>  
   of Hormah . . . . . 1422<sup>a</sup> (Ewing)  
 Atheism . . . . . 318<sup>a</sup> (Kapp)  
   of Creation . . . . . 738<sup>a</sup> (J. Lindsay)  
   of God . . . . . 1250<sup>a</sup> (Rees)  
 Athenians . . . . . 319<sup>b</sup>  
   of Athens . . . . . 319<sup>b</sup> (Harry)  
 Athenobius . . . . . 319<sup>b</sup>  
 Athens . . . . . 319<sup>b</sup> (Harry)  
   Church in . . . . . 1903<sup>b</sup> (Cowan)  
   of Unknown God . . . . . 3037<sup>b</sup> (Easton)
- Athlai . . . . . 320<sup>b</sup>  
 Atipha (Hatipha) . . . . . 1343<sup>b</sup>  
 At One . . . . . 321<sup>a</sup>  
 Atonement . . . . . 321<sup>a</sup> (Carver); 627<sup>b</sup> (Orr)  
   Day of . . . . . 324<sup>b</sup> (Möller)  
     of Genesis . . . . . 1207<sup>a</sup> (Möller)  
     History of . . . . . 327<sup>a</sup>  
     of Holy of Holies . . . . . 1405<sup>a</sup> (Caldecott)  
     Legal enactments . . . . . 324<sup>b</sup>  
     of Leviticus . . . . . 1876<sup>a</sup> (Möller)  
     of Mercy-seat . . . . . 2036<sup>a</sup> (Caldecott)  
     of Propitiation . . . . . 2467<sup>a</sup> (Carver)  
     Significance of . . . . . 326<sup>a</sup>  
   And forgiveness . . . . . 1135<sup>a</sup>  
   of Imputation . . . . . 1462<sup>a</sup> (Hodge)  
   of Lamb of God . . . . . 1823<sup>a</sup> (Bevan)  
   Love as secret of . . . . . 1698<sup>b</sup> (Law)  
   of Mediation . . . . . 2018<sup>a</sup> (Edwards)  
   of Obedience of Christ . . . . . 2175<sup>b</sup> (Crannell)  
   of Pauline Theology . . . . . 2291<sup>b</sup> (Easton)  
   of Propitiation . . . . . 2467<sup>a</sup> (Carver)  
   of Reconcile . . . . . 2536<sup>a</sup> (M'Caig)  
   of Salvation . . . . . 2669<sup>b</sup> (Easton)  
 Atroth-beth-joab . . . . . 328<sup>a</sup>  
   of Joab . . . . . 1677<sup>b</sup> (Roberts)  
 Atroth-shophan . . . . . 328<sup>a</sup>  
 Attai . . . . . 328<sup>a</sup>  
 Attain . . . . . 328<sup>a</sup> (Hirsch)  
 Attalia . . . . . 328<sup>a</sup> (Banks)  
   of Pamphylia . . . . . 2236<sup>b</sup> (Banks)  
 Attalus . . . . . 328<sup>b</sup>  
 Attend, Attendance . . . . . 328<sup>b</sup>  
 Attent, Attentive . . . . . 328<sup>b</sup>  
 Atharates . . . . . 328<sup>b</sup>  
   of Tirshatha . . . . . 2986<sup>b</sup> (R. D. Wilson)  
 Atharias, Atharias  
   of Tirshatha . . . . . 2986<sup>b</sup> (R. D. Wilson)  
 Attire, Dyed Attire . . . . . 328<sup>a</sup> (Eager)  
   of Dress . . . . . 875<sup>b</sup> (Eager)  
 Attitudes . . . . . 329<sup>a</sup> (W. W. Davies)  
   of Adoration . . . . . 60<sup>a</sup> (Edwards)  
   Bowing . . . . . 330<sup>a</sup>  
   of Gesture . . . . . 1220<sup>a</sup> (W. L. Walker)  
   Kneeling . . . . . 330<sup>a</sup>  
     of Knee, Kneel . . . . . 1815<sup>a</sup> (Easton)  
   Prostration . . . . . 330<sup>b</sup>  
   Standing . . . . . 329<sup>b</sup>  
 Attus (Hattush) . . . . . 1343<sup>b</sup> (Wolf)  
 Audience . . . . . 331<sup>a</sup>  
 Augia . . . . . 331<sup>a</sup>  
 Augurs' Oak . . . . . 331<sup>a</sup> (T. W. Davies)  
   of Divination . . . . . 860<sup>a</sup> (T. W. Davies)  
   of Meonenim . . . . . 2033<sup>b</sup>  
 Augury . . . . . 331<sup>a</sup> (T. W. Davies)  
   Among the Greeks . . . . . 331<sup>b</sup>  
   Among the Hebrews . . . . . 331<sup>b</sup>  
   Among the Romans . . . . . 331<sup>a</sup>  
   of Astrology . . . . . 296<sup>a</sup> (Maunder)  
   of Divination . . . . . 860<sup>a</sup> (T. W. Davies)  
 Augustan Band . . . . . 258<sup>a</sup> (Allen); 382<sup>b</sup> (Nicol)  
   of Army, Roman . . . . . 257<sup>a</sup> (Allen)

- Augustus . . . . . 332<sup>a</sup> (Hutchison)  
   cf Emperor . . . . . 941<sup>b</sup>  
 Aul (Awl) . . . . . 341<sup>a</sup>  
 Aunt . . . . . 332<sup>b</sup>  
   cf Relationships,  
     Family . . . . . 2554<sup>a</sup> (N. and E. D. Isaacs)  
 Auranitis (Hauran) . . . . . 1344<sup>a</sup> (Ewing)  
 Austere . . . . . 322<sup>b</sup> (Pratt)  
 Author . . . . . 333<sup>a</sup> (Edwards)  
 Authority, in General  
   cf Authority, in Re-  
     ligion . . . . . 333<sup>a</sup> (Rees)  
   cf Truth . . . . . 3025<sup>a</sup> (Carver)  
 Authority, in Religion . . . . . 333<sup>a</sup> (Rees)  
   Biblical references . . . . . 334<sup>b</sup>  
   Biblical teaching . . . . . 335<sup>a</sup>  
     NT teaching . . . . . 336<sup>a</sup>  
       cf Doctrine . . . . . 866<sup>b</sup> (Rees)  
     OT teaching . . . . . 335<sup>b</sup>  
   Classification of theo-  
     ries . . . . . 338<sup>b</sup>  
   Ecclesiastical doctrine . . . . . 337<sup>b</sup>  
     Absolutism . . . . . 338<sup>a</sup>  
     Logos . . . . . 337<sup>b</sup>  
     Reformation princi-  
       ples . . . . . 338<sup>a</sup>  
     Skepticism . . . . . 338<sup>a</sup>  
   General idea . . . . . 333<sup>b</sup>  
 Authorized Version . . . . . 469<sup>a</sup> (Orr)  
   cf English Versions . . . . . 945<sup>b</sup> (Hutchison)  
 Auxilia, Roman . . . . . 257<sup>b</sup> (Allen)  
 Ava (Avva) . . . . . 340<sup>b</sup>  
 Avail . . . . . 340<sup>a</sup>  
 Avaran . . . . . 340<sup>a</sup>  
 Aven . . . . . 340<sup>a</sup>  
 Avenge, Avenger . . . . . 340<sup>a</sup> (Breslich)  
   cf Goel . . . . . 1272<sup>b</sup> (Breslich)  
   cf Revenge . . . . . 2587<sup>a</sup> (Breslich)  
 Averse . . . . . 340<sup>b</sup>  
 Avesta  
   cf Persian Religion . . . . . 2331<sup>b</sup> (Tisdall)  
 Avim (Avva) . . . . . 340<sup>b</sup>  
 Avims (Avvim) . . . . . 340<sup>b</sup> (Sayce)  
 Avites (Avvim) . . . . . 340<sup>b</sup> (Sayce)  
 Avith . . . . . 340<sup>b</sup>  
 Avoid . . . . . 340<sup>b</sup>  
 Avouch . . . . . 340<sup>b</sup>  
 Avva . . . . . 340<sup>b</sup>  
 Avvim, Avites . . . . . 340<sup>b</sup> (Sayce)  
 Await . . . . . 340<sup>b</sup>  
 Awake . . . . . 340<sup>b</sup> (Pratt)  
 Away with . . . . . 341<sup>a</sup>  
 Awe . . . . . 341<sup>a</sup> (Edwards)  
 Awl . . . . . 341<sup>a</sup>  
   cf Bore . . . . . 504<sup>a</sup> (T. Lewis)  
   cf Tools . . . . . 2998<sup>b</sup> (Easton)  
 Ax, Axhead . . . . . 341<sup>a</sup> (Patch)  
   cf Tools . . . . . 2998<sup>b</sup> (Easton)  
 Axle, Axle-tree  
   cf Wheel . . . . . 3082<sup>b</sup> (Easton)  
 Ayin . . . . . 342<sup>a</sup> (W. W. Davies)  
 Azael . . . . . 342<sup>a</sup>  
 Azaelus . . . . . 342<sup>a</sup>  
 Azal (Azal) . . . . . 344<sup>b</sup>  
 Azaliah . . . . . 342<sup>a</sup>  
 Azaniah . . . . . 342<sup>a</sup>  
 Azaphion (Assaphioth) . . . . . 288<sup>a</sup>  
 Azara (Asara) . . . . . 263<sup>a</sup>  
 Azarael (Azarel) . . . . . 342<sup>a</sup>  
 Azaraias . . . . . 342<sup>a</sup>  
   cf Seraiah . . . . . 2732<sup>a</sup> (Wolf)  
 Azareel (Azarel) . . . . . 342<sup>a</sup>  
 Azarel . . . . . 342<sup>a</sup>  
   cf Uzziel . . . . . 3044<sup>b</sup> (Roberts)  
 Azariah . . . . . 342<sup>a</sup> (W. W. Davies)  
   cf Oded . . . . . 2178<sup>b</sup> (Roberts)  
 Azarias . . . . . 324<sup>b</sup>  
   Prayer of . . . . . 787<sup>b</sup> (R. D. Wilson)  
   cf Saraias . . . . . 2691<sup>b</sup>  
 Azaru . . . . . 342<sup>b</sup>  
 Azaz . . . . . 342<sup>b</sup>  
 Azazel . . . . . 342<sup>a</sup> (Möller)  
   cf Night-monster . . . . . 2144<sup>b</sup> (Sweet)  
 Azaziah . . . . . 344<sup>a</sup>  
 Azbasareh (Asbasareth) . . . . . 263<sup>a</sup>  
 Azbasareth (Asbasareth) . . . . . 263<sup>a</sup>  
 Azbuk . . . . . 344<sup>a</sup>  
 Azekah . . . . . 344<sup>a</sup> (Masterman)  
 Azel . . . . . 344<sup>b</sup>  
 Azem . . . . . 344<sup>b</sup>  
 Azephurith (Arsiphurith) . . . . . 260<sup>a</sup>  
 Azetas . . . . . 344<sup>b</sup>  
 Azgad . . . . . 344<sup>b</sup>  
 Aziei . . . . . 344<sup>b</sup>  
 Aziel . . . . . 344<sup>b</sup>  
 Aziza . . . . . 344<sup>b</sup>  
 Azmaveth (person) . . . . . 344<sup>b</sup>  
 Azmaveth (place) . . . . . 345<sup>a</sup>  
 Azmon . . . . . 345<sup>a</sup>  
 Aznoth-tabor . . . . . 345<sup>a</sup>  
 Azor . . . . . 345<sup>a</sup>  
 Azotus . . . . . 345<sup>a</sup>  
 Azriel . . . . . 345<sup>a</sup>  
 Azrikam . . . . . 345<sup>a</sup>  
 Azubah . . . . . 345<sup>b</sup>  
 Azur (Azzur) . . . . . 345<sup>b</sup>  
 Azuran (Azaru) . . . . . 342<sup>b</sup>  
 Azzah . . . . . 345<sup>b</sup>  
   cf Gaza . . . . . 1178<sup>b</sup> (Porter)  
 Azzan . . . . . 345<sup>b</sup>  
 Azzur . . . . . 345<sup>b</sup>  
 Baal . . . . . 345<sup>a</sup> (Sayce); 346<sup>b</sup> (Pratt)  
   Attributes . . . . . 345<sup>b</sup>  
   cf Baalath-beer . . . . . 347<sup>a</sup>  
   cf Beelzebub . . . . . 423<sup>b</sup> (Rees)  
   Forms of . . . . . 346<sup>a</sup>  
   cf Gezer . . . . . 1224<sup>a</sup> (Masterman)  
   cf Gods . . . . . 1271<sup>a</sup> (Reeve)  
   cf Jezebel . . . . . 1675<sup>b</sup> (Roberts)  
   Name and character . . . . . 345<sup>a</sup>  
   cf Phoenicia . . . . . 2389<sup>b</sup> (Porter)  
   cf Semites, Semitic  
     Religion . . . . . 2717<sup>a</sup> (Mack)

- Baal—*continued*  
 Temples of . . . . . 346<sup>a</sup>  
 Worship . . . . . 346<sup>a</sup>  
 Baalah . . . . . 347<sup>a</sup> (Masterman)  
 Baalath . . . . . 347<sup>a</sup>  
 Baalath-beer . . . . . 347<sup>a</sup>  
 Baalbek . . . . . 347<sup>a</sup>  
 cf Aven . . . . . 340<sup>a</sup>  
 cf On . . . . . 2193<sup>a</sup> (Kyle)  
 Baal-berith . . . . . 347<sup>a</sup>  
 cf Baal . . . . . 346<sup>a</sup> (Sayce)  
 Baale-judah  
 cf Kiriath-jearim . . . . . 1811<sup>b</sup> (Masterman)  
 Baal-gad . . . . . 347<sup>a</sup>  
 Baal-hamon  
 cf Baal . . . . . 346<sup>b</sup> (Sayce)  
 Baal-hanan . . . . . 347<sup>a</sup>  
 Baal-hazor . . . . . 347<sup>a</sup>  
 Baal-hermon . . . . . 347<sup>b</sup>  
 cf Baal . . . . . 346<sup>b</sup> (Sayce)  
 Baali . . . . . 347<sup>b</sup>  
 Baalim  
 cf Baal . . . . . 345<sup>a</sup> (Sayce)  
 Baalis . . . . . 347<sup>b</sup>  
 Baal-meon . . . . . 347<sup>b</sup> (Ewing)  
 Baal-peor  
 cf Baal . . . . . 346<sup>b</sup> (Sayce)  
 cf Zimri . . . . . 3149<sup>b</sup> (Roberts)  
 Baal-perazim . . . . . 347<sup>b</sup> (Masterman)  
 cf Perazim, Mount . . . . . 2320<sup>a</sup>  
 Baalsamus . . . . . 347<sup>b</sup>  
 Baal-shalishah . . . . . 347<sup>b</sup> (Ewing)  
 Baal-tamar . . . . . 348<sup>a</sup>  
 Baalzebub . . . . . 348<sup>a</sup>  
 cf Baal . . . . . 346<sup>b</sup> (Sayce)  
 cf Gods . . . . . 1271<sup>a</sup> (Reeve)  
 Baal-zephon . . . . . 348<sup>a</sup> (Conder)  
 Baana . . . . . 348<sup>a</sup>  
 Baanah . . . . . 348<sup>a</sup>  
 Baani . . . . . 348<sup>a</sup>  
 Baani (Apoc)  
 cf Maani . . . . . 1945<sup>b</sup>  
 Baanias  
 cf Banneas (Apoc) . . . . . 384<sup>a</sup>  
 Baara . . . . . 348<sup>a</sup>  
 Baaseiah . . . . . 348<sup>a</sup>  
 cf Maaseiah . . . . . 1946<sup>a</sup> (Lees)  
 Baasha . . . . . 348<sup>a</sup> (Breshlich); 261<sup>b</sup>  
 cf Elah . . . . . 916<sup>b</sup> (Mosiman)  
 cf Zimri . . . . . 3150<sup>a</sup> (Mosiman)  
 Babbler . . . . . 348<sup>b</sup> (Rees)  
 Babbling . . . . . 348<sup>b</sup>  
 Babe . . . . . 348<sup>b</sup> (Rees)  
 Babel, Babylon (topo-  
 graphical) . . . . . 349<sup>a</sup> (Clay)  
 Babel, Babylon . . . . . 350<sup>a</sup> (Pinches)  
 cf Calah . . . . . 539<sup>b</sup> (Pinches)  
 Date of foundation . . . . . 350<sup>a</sup>; 355<sup>b</sup>  
 Descriptions of ruins . . . . . 352<sup>b</sup>  
 Hanging gardens . . . . . 351<sup>a</sup>; 354<sup>b</sup>  
 Location, plan and  
 temple . . . . . 350<sup>b</sup>
- Babel, Babylon—*continued*  
 Modern explorations . . . . . 352<sup>b</sup>  
 Nebuchadrezzar's ac-  
 count . . . . . 351<sup>b</sup>  
 Palace and walls  
 (Ctesias) . . . . . 351<sup>a</sup>  
 Palaces . . . . . 351<sup>b</sup>; 353<sup>b</sup>  
 cf Shinar . . . . . 2772<sup>b</sup> (Pinches)  
 Temple of Belus . . . . . 351<sup>a</sup>  
 Temple restored . . . . . 352<sup>a</sup>  
 cf Babel, Tower of . . . . . 355<sup>b</sup> (Pinches)  
 cf Tongues, Con-  
 fusion of . . . . . 2994<sup>b</sup> (Easton)  
 Babel, Tower of . . . . . 355<sup>b</sup> (Pinches)  
 Babylonian descrip-  
 tion . . . . . 356<sup>a</sup>  
 cf Calah . . . . . 539<sup>b</sup> (Pinches)  
 Herodotus' description . . . . . 357<sup>a</sup>  
 Location . . . . . 355<sup>b</sup>  
 cf Shinar . . . . . 2772<sup>b</sup> (Pinches)  
 cf Tongues, Con-  
 fusion of . . . . . 2994<sup>b</sup> (Easton)  
 Walk through Baby-  
 lon . . . . . 354<sup>a</sup>  
 Walls and gates . . . . . 350<sup>b</sup>  
 Work of Nebuchadrez-  
 zar . . . . . 361<sup>b</sup>  
 Works of Semiramis  
 and Nitocris . . . . . 350<sup>b</sup>  
 Babi . . . . . 358<sup>a</sup>  
 Babylon in NT . . . . . 358<sup>a</sup> (Fortune)  
 Babylon in OT  
 cf Babel, Babylon . . . . . 350<sup>a</sup> (Pinches)  
 Babylonia . . . . . 358<sup>b</sup> (Clay)  
 Accommodation . . . . . 33<sup>a</sup> (Sweet)  
 Architecture . . . . . 361<sup>b</sup>  
 cf Babel, Babylon . . . . . 351<sup>b</sup> (Pinches)  
 Art . . . . . 362<sup>a</sup>  
 Lapidist's work . . . . . 362<sup>a</sup>  
 Metal work . . . . . 362<sup>a</sup>  
 Sculpture . . . . . 362<sup>a</sup>  
 Babylonian Dynasty . . . . . 367<sup>a</sup>  
 Ashurbanipal . . . . . 367<sup>b</sup>  
 Esarhaddon . . . . . 367<sup>a</sup>  
 Nabopolassar . . . . . 367<sup>b</sup>  
 Sennacherib . . . . . 367<sup>a</sup>  
 Cassite Dynasty . . . . . 366<sup>a</sup>  
 City kingdoms . . . . . 364<sup>b</sup>  
 Excavations and tab-  
 lets . . . . . 359<sup>a</sup>  
 First dynasty of  
 Babylon . . . . . 365<sup>b</sup>  
 Hammurabi . . . . . 366<sup>a</sup>  
 cf Gods . . . . . 1270<sup>b</sup> (Reeve)  
 Inhabitants . . . . . 360<sup>a</sup>  
 Semites . . . . . 360<sup>a</sup>  
 Sumerians . . . . . 360<sup>a</sup>  
 cf Inscription . . . . . 1473<sup>a</sup>  
 Isin Dynasty . . . . . 366<sup>b</sup>  
 Nebuchadrezzar I . . . . . 366<sup>b</sup>  
 Language . . . . . 361<sup>a</sup>

Babylonia—*continued*

- Libraries . . . . . 363<sup>a</sup>  
 Ashurbanipal . . . . . 363<sup>a</sup>  
 At Nippur . . . . . 363<sup>a</sup>  
 At Sippar . . . . . 363<sup>a</sup>  
 Literature . . . . . 362<sup>b</sup>  
 cf Ashurbanipal . . . . . 271<sup>b</sup> (Clay)  
 cf Babylonia and Assyria, Religion of . . . . . 368<sup>b</sup> (Rogers)  
 cf Code of Hammurabi . . . . . 1327<sup>a</sup> (Ungnad)  
 cf Tell el-Amarna . . . . . 2925<sup>b</sup> (Kyle)  
 Names, personal . . . . . 363<sup>b</sup>  
 Neo-Babylonian Empire . . . . . 367<sup>b</sup>  
 cf Captivity . . . . . 572<sup>b</sup> (Nicol)  
 Evil-Merodach . . . . . 367<sup>b</sup>  
 Nabonidus . . . . . 367<sup>b</sup>  
 Nabopolassar . . . . . 367<sup>b</sup>  
 Nebuchadrezzar II . . . . . 367<sup>b</sup>  
 Persian rule . . . . . 368<sup>a</sup>  
 Cambyses . . . . . 368<sup>a</sup>  
 Cyrus . . . . . 368<sup>a</sup>  
 Sealand Dynasty . . . . . 366<sup>a</sup>  
 cf Semites, Semitic Religion . . . . . 2717<sup>a</sup> (Mack)  
 Writing . . . . . 361<sup>a</sup>
- Babylonia and Assyria,  
 Religion of . . . . . 368<sup>b</sup> (Rogers)  
 Astral theory of the universe . . . . . 374<sup>a</sup>  
 History . . . . . 369<sup>a</sup>  
 Major and minor deities . . . . . 369<sup>b</sup>  
 Monotheism an impossible conception . . . . . 370<sup>a</sup>  
 Hymns and prayers . . . . . 372<sup>a</sup>  
 Life after death . . . . . 373<sup>a</sup>  
 Magic . . . . . 373<sup>a</sup>  
 Maqlu . . . . . 373<sup>a</sup>  
 Shurpu . . . . . 373<sup>a</sup>  
 cf Merodach . . . . . 2036<sup>b</sup>  
 Myths and epics . . . . . 373<sup>b</sup>  
 Adapa, story of . . . . . 373<sup>b</sup>  
 Deluge, story of . . . . . 374<sup>a</sup>  
 Gilgames, story of . . . . . 374<sup>a</sup>  
 cf Nebo . . . . . 2126<sup>b</sup>  
 cf Nergal . . . . . 2134<sup>b</sup>  
 cf Nimrod . . . . . 2147<sup>b</sup> (Mack)  
 cf Nisroch . . . . . 2153<sup>a</sup>  
 Pantheon . . . . . 370<sup>b</sup>  
 Anu . . . . . 370<sup>b</sup>  
 Asshur . . . . . 372<sup>a</sup>  
 Ea . . . . . 370<sup>b</sup>  
 Enlil . . . . . 370<sup>b</sup>  
 Ishtar . . . . . 371<sup>a</sup>  
 Marduk . . . . . 371<sup>b</sup>  
 Nabu . . . . . 371<sup>b</sup>  
 Nergal . . . . . 371<sup>b</sup>  
 Ninib . . . . . 372<sup>a</sup>  
 Rammon . . . . . 372<sup>a</sup>

- Babylonia and Assyria, Religion of—*continued*  
 Pantheon—*continued*  
 Shamash . . . . . 371<sup>a</sup>  
 Sin . . . . . 371<sup>a</sup>  
 Tammuz . . . . . 372<sup>a</sup>  
 Relations with religion of Israel . . . . . 375<sup>a</sup>  
 cf World, Cosmological . . . . . 3107<sup>b</sup> (Orr)
- Babylonian Captivity . . . . . 375<sup>b</sup>  
 cf Captivity . . . . . 569<sup>b</sup> (Nicol)
- Babylonians . . . . . 375<sup>b</sup>  
 cf Jeremiah . . . . . 1589<sup>b</sup> (Orelli)
- Babylonish Garment . . . . . 375<sup>b</sup>  
 Babylonish Mantle . . . . . 375<sup>b</sup> (Beecher)  
 Baca . . . . . 375<sup>b</sup> (Beecher)  
 Bacchides . . . . . 375<sup>b</sup> (Breslich)  
 cf Alcimus . . . . . 89<sup>b</sup> (Mack)  
 cf Maccabees (Jonathan, Judas) . . . . . 1947<sup>a</sup> (Hutchison)  
 cf Nicanor . . . . . 2141<sup>a</sup> (Angus)
- Bacchurus . . . . . 376<sup>a</sup>  
 Bacchus . . . . . 376<sup>a</sup> (Rees)  
 cf Abomination of Desolation . . . . . 17<sup>b</sup> (Hirsch)  
 cf Dionysia . . . . . 850<sup>a</sup> (Harry)
- Bacenor . . . . . 376<sup>a</sup>
- Bachrite  
 cf Becher . . . . . 421<sup>a</sup>
- Back, Back Parts . . . . . 376<sup>a</sup> (M. O. Evans)  
 Backbite . . . . . 376<sup>b</sup>  
 Backbiters . . . . . 376<sup>b</sup>  
 Backbiting . . . . . 376<sup>b</sup>
- Backside  
 cf Back . . . . . 376<sup>a</sup> (M. O. Evans)
- Backslide . . . . . 376<sup>b</sup>  
 cf Apostasy . . . . . 202<sup>a</sup> (Pratt)  
 Backslider . . . . . 376<sup>b</sup>
- Badger . . . . . 376<sup>b</sup> (Day)  
 cf Porpoise . . . . . 2422<sup>a</sup>  
 cf Sealskin . . . . . 2709<sup>b</sup>
- Bacan . . . . . 377<sup>a</sup>  
 cf Maon . . . . . 1984<sup>a</sup> (Ewing)
- Bag . . . . . 377<sup>a</sup> (Eager)  
 cf Scrip . . . . . 2705<sup>b</sup>
- Baggage . . . . . 377<sup>b</sup> (M. O. Evans)  
 Bago . . . . . 378<sup>a</sup>  
 Bagoas . . . . . 378<sup>a</sup>  
 cf Judith . . . . . 1778<sup>a</sup>
- Bagoi . . . . . 378<sup>a</sup>  
 Baharumite, Barhumite . . . . . 378<sup>a</sup>  
 Bahurim . . . . . 378<sup>a</sup> (Ewing)  
 cf Olives, Mount of . . . . . 2186<sup>b</sup> (Masterman)
- Baiterus . . . . . 378<sup>a</sup>  
 Bajith (Bayith) . . . . . 378<sup>a</sup>  
 Bakbakkar . . . . . 378<sup>a</sup>  
 Bakbuk . . . . . 378<sup>a</sup>  
 Bakbukiah . . . . . 378<sup>a</sup>  
 Bakemeats . . . . . 378<sup>a</sup>  
 cf Bread . . . . . 514<sup>b</sup> (Eager)  
 cf Food . . . . . 1121<sup>b</sup> (Eager)



- Baking  
 cf Bread . . . . . 514<sup>b</sup> (Eager)
- Baking Pan  
 cf Bread . . . . . 514<sup>b</sup> (Eager)  
 cf Pan . . . . . 2237<sup>a</sup> (Betheridge)
- Balaam . . . . . 378<sup>b</sup> (Baur)  
 cf Ep. of Jude . . . . . 1770<sup>a</sup> (Moorehead)  
 cf Zimri . . . . . 3149<sup>b</sup> (Roberts)
- Balac  
 cf Balak . . . . . 379<sup>b</sup>
- Baladan . . . . . 379<sup>b</sup> (R. D. Wilson)
- Balah . . . . . 379<sup>b</sup>
- Balak . . . . . 379<sup>b</sup>  
 cf Balaam . . . . . 378<sup>b</sup> (Baur)
- Balamon . . . . . 379<sup>b</sup>
- Balance . . . . . 379<sup>b</sup> (Eager)  
 cf Scales . . . . . 2701<sup>a</sup> (Luering)  
 cf Weights and Measures 3079<sup>a</sup> (Porter)
- Balancings . . . . . 380<sup>b</sup>
- Balasmus  
 cf Baalsamus . . . . . 347<sup>b</sup>
- Bald Locust  
 cf Locust . . . . . 1907<sup>b</sup> (Day)
- Baldness . . . . . 380<sup>b</sup> (Kapp)  
 cf Hair . . . . . 1320<sup>a</sup> (Luering)  
 cf Shaving . . . . . 2751<sup>b</sup> (Orr)
- Ball . . . . . 381<sup>a</sup>  
 cf Games . . . . . 1168<sup>b</sup> (Smith)
- Balm . . . . . 381<sup>a</sup> (Macalister)
- Balm of Gilead . . . . . 381<sup>a</sup> (Masterman)  
 cf Gilead . . . . . 1230<sup>b</sup> (Ewing)
- Balnuus . . . . . 381<sup>a</sup>
- Balsam . . . . . 381<sup>b</sup> (Macalister)  
 cf Balm . . . . . 381<sup>a</sup> (Macalister)  
 cf Myrrh . . . . . 2102<sup>b</sup> (Masterman)
- Baltasar . . . . . 381<sup>b</sup> (Breslich)
- Bamah . . . . . 381<sup>b</sup>
- Bamoth, Bamoth-Baal . . . . . 381<sup>b</sup>  
 cf High Place . . . . . 1390<sup>a</sup> (Easton)
- Ban . . . . . 382<sup>a</sup>
- Banaias . . . . . 382<sup>a</sup>
- Band . . . . . 382<sup>a</sup> (Rees; Nicol)  
 Augustan Band . . . . . 382<sup>b</sup>; 358<sup>a</sup> (Allen)  
 Italian Band . . . . . 382<sup>b</sup>; 358<sup>b</sup> (Allen)  
 cf Julius . . . . . 1780<sup>b</sup>
- Bands, Beauty and . . . . . 421<sup>a</sup>
- Bands of Rudder . . . . . 2624<sup>b</sup>
- Bani . . . . . 382<sup>b</sup> (Breslich)  
 cf Mani . . . . . 1981<sup>b</sup>
- Banias (person) . . . . . 383<sup>a</sup>
- Banias (place)  
 cf Caesarea Philippi . . . . . 536<sup>a</sup> (Ewing)
- Banid (Banias) . . . . . 383<sup>a</sup>
- Banishment  
 cf Punishments . . . . . 2504<sup>b</sup> (Hirsch)
- Bank . . . . . 383<sup>a</sup> (M. O. Evans)
- Bank, Banking . . . . . 383<sup>a</sup> (Eager)  
 Allusions and interpretations . . . . . 384<sup>a</sup>  
 Among Hebrews . . . . . 383<sup>b</sup>  
 Historical . . . . . 383<sup>a</sup>  
 In NT times . . . . . 383<sup>b</sup>
- Bannaia (Sabanneus) . . . . . 2629<sup>b</sup>
- Bannas . . . . . 384<sup>a</sup>
- Banneas . . . . . 384<sup>a</sup>
- Banner . . . . . 384<sup>a</sup> (Eager)
- Bannus . . . . . 384<sup>b</sup>
- Banquet . . . . . 384<sup>b</sup> (Eager)  
 Ancient Hebrew customs . . . . . 384<sup>b</sup>  
 Christ's teaching and practice . . . . . 385<sup>a</sup>  
 Marriage feast . . . . . 385<sup>a</sup>  
 cf Meals, Meal-time . . . . . 2015<sup>a</sup> (Eager)
- Banuas (Bannas) . . . . . 384<sup>a</sup>
- Baptism  
 cf Barnabas, Ep. of . . . . . 1902<sup>a</sup> (Cowan)  
 In Didache . . . . . 1899<sup>a</sup> (Cowan)  
 cf Holy Spirit . . . . . 1406<sup>a</sup> (Mullins)  
 Influence of Greek religion on . . . . . 1304<sup>b</sup> (Fairbanks)  
 cf Jesus Christ . . . . . 1635<sup>a</sup> (Orr)  
 cf John the Baptist . . . . . 1709<sup>b</sup> (Miller); 1710<sup>a</sup> (Miller)  
 cf Sacraments . . . . . 2636<sup>a</sup> (Lambert)  
 cf Seal . . . . . 2709<sup>b</sup> (Edwards)  
 cf Trine Immersion . . . . . 3011<sup>b</sup> (Kurtz)
- Baptism (Baptist Interpretation) . . . . . 385<sup>b</sup> (A. T. Robertson)
- Infant baptism . . . . . 388<sup>a</sup>
- Meaning . . . . . 385<sup>b</sup>  
 Baptismal regeneration . . . . . 387<sup>b</sup>; 397<sup>a</sup> (Orr; Bishop; Dau)
- Didache . . . . . 387<sup>b</sup>
- Greek usage . . . . . 386<sup>b</sup>
- NT usage . . . . . 386<sup>b</sup>
- Proselyte baptism . . . . . 386<sup>a</sup>
- Terminology . . . . . 385<sup>b</sup>
- Obligation . . . . . 388<sup>b</sup>
- Baptism (Lutheran Doctrine) . . . . . 394<sup>a</sup> (Dau)
- Difficulties . . . . . 396<sup>a</sup>  
 Baptism for the dead 397<sup>a</sup>; 399<sup>a</sup> (Rees)  
 Baptism of John . . . . . 396<sup>b</sup>  
 Genuineness of records . . . . . 396<sup>a</sup>  
 Infant baptism . . . . . 396<sup>b</sup>  
 Paul and baptism . . . . . 397<sup>a</sup>  
 Use of formula in NT times . . . . . 396<sup>a</sup>  
 Was baptism a new ordinance . . . . . 396<sup>a</sup>
- Ordinance . . . . . 394<sup>b</sup>  
 Biblical history . . . . . 395<sup>b</sup>  
 Scriptural teaching . . . . . 394<sup>b</sup>  
 Trinity in formula . . . . . 395<sup>b</sup>  
 Types of baptism . . . . . 395<sup>b</sup>  
 Origin and application . . . . . 394<sup>a</sup>
- Baptism (Non-Immersionist View) . . . . . 388<sup>b</sup> (T. M. Lindsay)
- Christian baptism . . . . . 389<sup>b</sup>  
 Administration of rite . . . . . 389<sup>b</sup>

Baptism (Non-Immersionist View)—*continued*Christian baptism—*continued*

- Affusion . . . . . 390<sup>a</sup>  
 Aspersion . . . . . 390<sup>b</sup>  
 Baptism for dead . . . 392<sup>a</sup>; 399<sup>a</sup> (Rees)  
 Baptism of infants . . 391<sup>b</sup>  
 Immersion . . . . . 390<sup>a</sup>  
 Who may perform  
   baptism . . . . . 391<sup>a</sup>  
 Doctrine of baptism . . 393<sup>a</sup>  
   Infant baptism . . . 393<sup>b</sup>  
 Formula of baptism . . 392<sup>b</sup>  
 Pre-Christian baptism . 389<sup>a</sup>  
   Baptism of John . . . 389<sup>a</sup>  
   Pagan practice . . . 389<sup>b</sup>  
   Proselyte baptism . . 389<sup>a</sup>  
 Scriptural names . . . 389<sup>a</sup>  
 Baptism for the Dead . . 399<sup>a</sup> (Rees); 397<sup>a</sup> (Dau)  
   Modern views . . . . . 399<sup>b</sup>  
   Patristic evidence . . . 399<sup>a</sup>  
   Paul's argument . . . 399<sup>a</sup>  
 Baptism of Fire . . . . . 399<sup>b</sup> (Kapp)  
   of Fire . . . . . 1112<sup>b</sup> (W. L. Walker)  
 Baptism of the Holy  
   Spirit . . . . . 399<sup>b</sup> (Mullins)  
   Biblical references . . 399<sup>b</sup>  
   Finality . . . . . 400<sup>b</sup>  
   Relation to other bap-  
   tisms . . . . . 401<sup>b</sup>  
   Significance . . . . . 400<sup>a</sup>  
     OT teachings . . . . 400<sup>a</sup>  
   Viewpoint of ascend-  
   ing Christ . . . . . 400<sup>b</sup>  
   Viewpoint of dis-  
   ciples . . . . . 400<sup>b</sup>  
 Baptism, Infant . . . . . 391<sup>b</sup> (T. M. Lindsay)  
 Baptismal Regeneration . 397<sup>a</sup> (Orr; Bishop; Dau)  
   General view . . . . . 397<sup>a</sup> (Orr)  
   High-church doctrine . 397<sup>b</sup> (Bishop)  
   Lutheran doctrine . . . 398<sup>a</sup> (Dau)  
 Baptist  
   of John the Baptist . . 1708<sup>b</sup> (Miller)  
 Bar . . . . . 401<sup>b</sup> (Hirsch)  
   of Door . . . . . 869<sup>a</sup> (Downer)  
   of Gate . . . . . 1175<sup>b</sup> (Easton)  
   of House . . . . . 1434<sup>b</sup> (A. C. Dickie)  
 Bar (prefix) . . . . . 401<sup>b</sup>; 433<sup>b</sup> (Breslich)  
   of Son, Sons . . . . . 2826<sup>a</sup> (Betteridge)  
 Barabbas . . . . . 402<sup>a</sup> (Rees)  
   of Jesus Christ, Arrest . 1673<sup>a</sup> (Maclaren)  
   of Thief . . . . . 2972<sup>a</sup> (Easton)  
 Barachel . . . . . 402<sup>b</sup>  
   of Buz . . . . . 535<sup>b</sup> (Wolf)  
   of Ram . . . . . 2527<sup>b</sup> (Wolf)  
 Barachiah . . . . . 402<sup>b</sup>  
 Barachias (Barachiah) . . 402<sup>b</sup>  
 Barak . . . . . 402<sup>b</sup> (Cohon); 814<sup>a</sup> (Mar-  
   golis)  
   of Bedan . . . . . 423<sup>a</sup>  
 Barbarian, Barbarous . . 402<sup>b</sup> (Rees)  
 Barber . . . . . 403<sup>a</sup> (Eager)  
   of Hair . . . . . 1320<sup>a</sup> (Luering)  
   of Razor . . . . . 2533<sup>b</sup>

- Barchus . . . . . 403<sup>b</sup>  
 Bar-cochba . . . . . 629<sup>a</sup> (Orr)  
 Barefoot . . . . . 403<sup>b</sup> (Eager)  
   Ancient custom . . . . 404<sup>a</sup>  
   Priests on duty . . . . 404<sup>a</sup>  
 Barhumite (Baharumite) . 378<sup>a</sup>  
 Bariah . . . . . 404<sup>b</sup>  
 Bar-Jesus . . . . . 404<sup>b</sup> (S. F. Hunter)  
   of Magic . . . . . 1963<sup>a</sup> (T. W. Davies)  
 Bar-Jonah . . . . . 404<sup>b</sup> (Edwards)  
 Barkos . . . . . 404<sup>b</sup>  
 Barley . . . . . 405<sup>a</sup> (Masterman); 1122<sup>a</sup>  
   (Eager)  
   of Jealousy . . . . . 1572<sup>b</sup> (Forrester)  
   of Weights and Meas-  
   ures . . . . . 3079<sup>a</sup> (Porter)  
 Barn . . . . . 405<sup>a</sup> (M. O. Evans)  
   of Agriculture . . . . . 75<sup>b</sup> (Patch)  
   of Garner . . . . . 1175<sup>b</sup>  
 Barnabas . . . . . 405<sup>b</sup> (Jacobs)  
   In Galatians . . . . . 1161<sup>b</sup> (G. G. Findlay)  
   of Joseph . . . . . 1736<sup>b</sup> (S. F. Hunter)  
   Relations with Silas . . 2790<sup>a</sup> (Kerr)  
 Barnabas, Epistle of  
   of Apocryphal Epis-  
   tles . . . . . 194<sup>b</sup> (J. M. Wilson)  
   of Literature, Sub-apos . 1901<sup>a</sup> (Cowan)  
 Barnabas, Gospel of  
   of Apocryphal Gospels . 195<sup>a</sup> (Hutchison)  
 Barodis . . . . . 406<sup>a</sup>  
 Barrel . . . . . 406<sup>a</sup> (Eager)  
   of House . . . . . 1434<sup>b</sup> (A. C. Dickie)  
   of Pitcher . . . . . 2401<sup>b</sup>  
 Barren, Barrenness . . . 406<sup>a</sup> (Rees)  
 Barsabas, Barsabbas  
   of Joseph Barsabbas . . 1740<sup>a</sup> (Kerr)  
   of Judas Barsabbas . . 1765<sup>a</sup> (S. F. Hunter)  
 Bartacus . . . . . 406<sup>b</sup>  
   of Apame . . . . . 160<sup>b</sup>  
   of Illustrious . . . . . 1449<sup>b</sup>  
 Bartholomew . . . . . 406<sup>b</sup> (Kerr)  
   of Nathanael . . . . . 2121<sup>a</sup> (Kerr)  
 Bartholomew, Gospel of  
   of Apocryphal Gospels . 195<sup>a</sup> (Hutchison)  
   of Bartholomew . . . . 406<sup>b</sup> (Kerr)  
 Bartimaeus . . . . . 406<sup>b</sup> (Rees)  
 Baruch . . . . . 407<sup>a</sup> (T. W. Davies)  
   of Jeremiah . . . . . 1590<sup>a</sup> (Orelli)  
 Baruch, Apocalypse of . . 166<sup>b</sup> (J. E. H. Thomson);  
   161<sup>b</sup> (J. E. H. Thomson)  
   Analysis . . . . . 167<sup>b</sup>  
   Authorship . . . . . 166<sup>b</sup>  
   Date . . . . . 168<sup>a</sup>  
   of Eschatology of OT . . 972<sup>a</sup> (Orr)  
   of Hope . . . . . 1419<sup>b</sup> (Easton)  
   Language . . . . . 167<sup>b</sup>  
   Relation to 2 Esdras . . 168<sup>b</sup>  
   Structure . . . . . 167<sup>b</sup>  
 Baruch, Book of . . . . . 407<sup>a</sup> (T. W. Davies)  
   Contents . . . . . 407<sup>b</sup>  
   Confession and  
   prayer . . . . . 407<sup>b</sup>

- Baruch, Book of—*continued*  
 Contents—*continued*  
 Dependence of wisdom . . . . . 408<sup>a</sup>  
 Historical introduction . . . . . 407<sup>b</sup>  
 Praise of wisdom . . . . . 408<sup>a</sup>  
 Words of cheer to  
 Israel . . . . . 408<sup>b</sup>  
 Dates of authorship . . . . . 409<sup>b</sup>  
 Linguistic analysis . . . . . 409<sup>a</sup>  
 Greek section . . . . . 409<sup>a</sup>  
 Hebrew section . . . . . 409<sup>a</sup>  
 Versions . . . . . 410<sup>a</sup>  
 Arabic . . . . . 410<sup>b</sup>  
 Latin . . . . . 410<sup>a</sup>  
 Syriac . . . . . 410<sup>b</sup>
- Barzillai . . . . . 410<sup>b</sup> (Rees)  
 cf Jaddus . . . . . 1557<sup>b</sup>  
 cf Zorzelleus . . . . . 3158<sup>b</sup>
- Basaloth . . . . . 410<sup>b</sup>  
 Bascama . . . . . 410<sup>b</sup>  
 Base . . . . . 410<sup>b</sup> (Rees)
- Basemath, Bashemath,  
 Basmath . . . . . 411<sup>a</sup> (Breslich)  
 cf Mahalath . . . . . 1965<sup>b</sup> (Orr)
- Bashan . . . . . 411<sup>a</sup> (Ewing)  
 cf Gilead . . . . . 1230<sup>a</sup> (Ewing)  
 cf Hauran . . . . . 1344<sup>a</sup> (Ewing)  
 cf Og . . . . . 2180<sup>b</sup> (Orr)
- Bashan-havvoth-jair . . . . . 1345<sup>a</sup> (Ewing)
- Bashan, Mount of  
 cf Hauran . . . . . 1344<sup>a</sup> (Ewing)
- Bashemath (Basemath) . . . . . 411<sup>a</sup> (Breslich)
- Basilisk . . . . . 411<sup>b</sup> (Day)  
 cf Adder . . . . . 55<sup>a</sup> (Day)  
 cf Cockatrice . . . . . 672<sup>b</sup> (Day)  
 cf Serpents . . . . . 2736<sup>a</sup> (Day)
- Basime . . . . . 365<sup>b</sup> (Clay)
- Basin, Bason . . . . . 412<sup>a</sup> (Eager)  
 cf Bowl . . . . . 511<sup>b</sup> (Eager)
- Basket . . . . . 412<sup>b</sup> (Eager)
- Basmath (Basemath) . . . . . 411<sup>a</sup> (Breslich)
- Bason, Basin . . . . . 412<sup>a</sup> (Eager)
- Bassai (Bassa) . . . . . 413<sup>b</sup>
- Bastai (Basthai) . . . . . 414<sup>a</sup>
- Bastard . . . . . 413<sup>b</sup> (Rees)
- Basthai . . . . . 414<sup>a</sup>
- Bat . . . . . 414<sup>a</sup> (Day)
- Batanaea . . . . . 414<sup>a</sup>
- Bath (liquid measure) . . . . . 414<sup>a</sup> (Porter)  
 cf Weights and Measures . . . . . 3079<sup>a</sup> (Porter)
- Bath, Bathing . . . . . 414<sup>a</sup> (Eager)  
 Bathing for health . . . . . 415<sup>a</sup>  
 Ceremonial purification . . . . . 415<sup>a</sup>  
 Greek vs. Semite ideas . . . . . 415<sup>a</sup>  
 cf Absolution . . . . . 24<sup>a</sup> (Jacobs)  
 Public baths . . . . . 414<sup>b</sup>
- Bath Kol . . . . . 415<sup>b</sup> (Van Pelt)  
 cf Sound . . . . . 2838<sup>a</sup> (Easton)
- Bath-rabbim, Gate of . . . . . 416<sup>a</sup> (Ewing)
- Bathsheba . . . . . 416<sup>a</sup> (Breslich)  
 cf Adonijah . . . . . 57<sup>a</sup> (Beecher)  
 cf Ammiel . . . . . 117<sup>a</sup> (Mack)  
 cf Bathshua . . . . . 416<sup>b</sup>  
 cf David . . . . . 790<sup>b</sup> (Weir)  
 cf Eliam . . . . . 929<sup>a</sup>  
 cf Nathan . . . . . 2120<sup>a</sup> (Roberts)  
 cf Solomon . . . . . 2822<sup>a</sup> (Weir)  
 cf Uriah, Urijah . . . . . 3039<sup>b</sup> (Easton)
- Bathshua . . . . . 416<sup>b</sup>  
 cf Bathsheba . . . . . 416<sup>a</sup> (Breslich)  
 cf Shua, Shuah . . . . . 2781<sup>a</sup>
- Bath-zacharias (Beth-zacharias) . . . . . 454<sup>a</sup>
- Battering Ram  
 cf Siege . . . . . 2786<sup>a</sup> (Nicol)
- Battle  
 cf War . . . . . 3069<sup>b</sup> (Nicol)
- Battle-axe  
 cf Arms (Offensive) . . . . . 251<sup>b</sup> (Nicol)
- Battle-how . . . . . 416<sup>b</sup> (Eager)  
 cf Archery . . . . . 233<sup>b</sup> (Eager)  
 cf Armor . . . . . 251<sup>a</sup> (Nicol)
- Battlement  
 cf Fortification . . . . . 1136<sup>b</sup> (Nicol)  
 cf House . . . . . 1434<sup>b</sup> (A. C. Dickie)
- Bavvai (Bavai) . . . . . 416<sup>b</sup>  
 cf Binnui . . . . . 474<sup>b</sup> (Wolf)
- Bay  
 cf Colors . . . . . 675<sup>a</sup> (Patch)
- Bay . . . . . 416<sup>b</sup>
- Bayith . . . . . 416<sup>b</sup>  
 cf Beth . . . . . 441<sup>b</sup>
- Bay Tree . . . . . 417<sup>a</sup>
- Bazlith, Bazluth . . . . . 417<sup>a</sup>
- Bdellium . . . . . 417<sup>a</sup> (Orr)
- Beach . . . . . 417<sup>a</sup>
- Beacon . . . . . 417<sup>a</sup>
- Bealiah . . . . . 417<sup>a</sup>
- Bealoth . . . . . 417<sup>a</sup>  
 cf Baalah . . . . . 347<sup>a</sup> (Masterman)
- Beam . . . . . 417<sup>a</sup> (A. C. Dickie)  
 cf Architecture . . . . . 234<sup>a</sup> (A. C. Dickie)  
 cf House . . . . . 1434<sup>b</sup> (A. C. Dickie)
- Bean (Baean) . . . . . 377<sup>a</sup>
- Beans . . . . . 417<sup>b</sup> (Masterman)
- Bear . . . . . 417<sup>b</sup> (Day)
- Bear, The (Arcturus) . . . . . 417<sup>b</sup>  
 cf Astronomy . . . . . 313<sup>a</sup> (Maunder)
- Bear, Born . . . . . 418<sup>a</sup>  
 cf Regeneration . . . . . 2546<sup>b</sup> (Nuelsen)
- Bear, Borne . . . . . 418<sup>a</sup> (M. O. Evans)
- Beard . . . . . 418<sup>a</sup> (Eager)
- Beast . . . . . 418<sup>b</sup> (Day)  
 cf Wild Beast . . . . . 3084<sup>a</sup> (Day)
- Beast Fight  
 cf Games . . . . . 1168<sup>b</sup> (Smith)
- Beaten Gold  
 cf Gold . . . . . 1274<sup>a</sup> (Patch)
- Beaten Oil . . . . . 2183<sup>a</sup>

- Beating  
   of Punishments . . . . . 2504<sup>b</sup> (Hirsch)  
 Beatitudes . . . . . 419<sup>a</sup> (Lambert)  
   Comparison of Mat-  
   thew and Luke . . . . . 419<sup>a</sup>  
   of Jesus Christ . . . . . 1642<sup>b</sup> (Orr)  
   Number . . . . . 419<sup>b</sup>  
   Origin of name . . . . . 419<sup>a</sup>  
   cf **S e r m o n o n**  
   Mount . . . . . 2734<sup>a</sup> (Miller)  
 Beautiful Gate  
   of Temple . . . . . 2930<sup>a</sup> (Caldecott; Orr)  
 Beauty . . . . . 420<sup>a</sup> (Caverno)  
   Aesthetics in nature . . . . . 421<sup>a</sup>  
   Aesthetics in Scripture . . . . . 420<sup>a</sup>  
 Beauty and Bands . . . . . 421<sup>a</sup>  
 Bebai . . . . . 421<sup>a</sup>  
 Because . . . . . 421<sup>a</sup>  
 Becher . . . . . 421<sup>a</sup>  
   cf Bered . . . . . 439<sup>b</sup>  
 Bechorath (Becorath) . . . . . 421<sup>b</sup>  
 Beck, Beckon . . . . . 421<sup>b</sup>  
 Become . . . . . 421<sup>b</sup>  
 Becorath . . . . . 421<sup>b</sup>  
 Bectileth . . . . . 421<sup>b</sup>  
 Bed, Bedchamber, Bed-  
   stead . . . . . 421<sup>b</sup> (Eager)  
   cf Couch . . . . . 723<sup>b</sup> (M. O. Evans)  
   Early forms . . . . . 421<sup>b</sup>  
   NT terms . . . . . 422<sup>b</sup>  
   OT terms . . . . . 422<sup>a</sup>  
 Bedad . . . . . 423<sup>a</sup>  
 Bedan . . . . . 423<sup>a</sup>  
 Bedchamber  
   of Bed . . . . . 421<sup>b</sup> (Eager)  
 Bedeiah . . . . . 423<sup>a</sup>  
   cf Pedias . . . . . 2295<sup>a</sup>  
 Bedstead  
   of Bed . . . . . 421<sup>b</sup> (Eager)  
 Bee . . . . . 423<sup>a</sup> (Day)  
 Beef  
   of Cattle . . . . . 583<sup>b</sup> (Day); 1123<sup>b</sup> (Eager)  
 Beeliada . . . . . 423<sup>b</sup>  
   cf Eliada . . . . . 928<sup>b</sup>  
 Beelsarus . . . . . 423<sup>b</sup>  
 Beeltethmus . . . . . 423<sup>b</sup>  
   cf Rathumus . . . . . 2533<sup>a</sup>  
 Beelzebub . . . . . 423<sup>b</sup> (Rees)  
   cf Baal . . . . . 346<sup>b</sup> (Sayce)  
   of Jesus Christ . . . . . 1644<sup>b</sup> (Orr)  
 Beer . . . . . 424<sup>a</sup>  
 Beera . . . . . 424<sup>a</sup>  
 Beerah . . . . . 424<sup>a</sup>  
 Beer-elim . . . . . 424<sup>a</sup>  
 Beeri . . . . . 424<sup>a</sup>  
 Beer-lahai-roi . . . . . 424<sup>a</sup> (S. F. Hunter)  
 Beeroth . . . . . 424<sup>a</sup> (Ewing)  
 Beeroth Bene-jaakan . . . . . 424<sup>b</sup>  
   cf **W a n d e r i n g s o f**  
   Israel . . . . . 3064<sup>a</sup> (Conder)  
 Beerothite (Beeroth) . . . . . 424<sup>a</sup> (Ewing)  
 Beersheba . . . . . 424<sup>b</sup> (Masterman)  
   Location . . . . . 424<sup>b</sup>  
   Meaning of name . . . . . 424<sup>b</sup>  
   Modern Beersheba . . . . . 424<sup>b</sup>  
   Sacred shrine . . . . . 424<sup>b</sup>  
   of Shibah . . . . . 2767<sup>b</sup>  
 Beeshterah (Ashtaroth) . . . . . 270<sup>a</sup> (Ewing)  
 Beetle . . . . . 425<sup>a</sup> (Day)  
   of Locust . . . . . 1907<sup>a</sup> (Day)  
 Beeves  
   of Cattle . . . . . 583<sup>b</sup> (Day)  
 Before . . . . . 425<sup>a</sup>  
 Beg, Beggar, Begging . . . . . 425<sup>a</sup> (Eager)  
   Begging denounced in  
   Jewish literature . . . . . 425<sup>b</sup>  
   Begging in Israel . . . . . 425<sup>a</sup>  
   In gospel age . . . . . 425<sup>b</sup>  
   Modern practice . . . . . 426<sup>a</sup>  
   Professional beggars . . . . . 425<sup>b</sup>  
 Beggarly . . . . . 426<sup>a</sup> (Kapp)  
 Begin . . . . . 426<sup>a</sup> (Jacobs)  
 Beginning . . . . . 426<sup>a</sup> (Kapp)  
   of Eternity . . . . . 1011<sup>a</sup> (J. Lindsay)  
   of Time . . . . . 2981<sup>b</sup> (Porter)  
 Begotten . . . . . 426<sup>b</sup> (Rees)  
   of First begotten . . . . . 1113<sup>a</sup> (Rees)  
   of Only begotten . . . . . 2196<sup>a</sup> (Rees)  
 Beguile . . . . . 426<sup>b</sup> (Kapp)  
   of Deceive . . . . . 816<sup>a</sup> (Farr)  
   of Delusion . . . . . 826<sup>a</sup> (Edwards)  
 Behalf . . . . . 426<sup>b</sup> (Jacobs)  
 Behavior . . . . . 426<sup>b</sup> (Pratt)  
 Beheading  
   of Punishments . . . . . 2504<sup>b</sup> (Hirsch)  
 Behemoth . . . . . 427<sup>a</sup> (Day)  
 Beholding . . . . . 427<sup>a</sup> (M. O. Evans)  
 Behoove . . . . . 427<sup>b</sup>  
 Beirut (Berytus) . . . . . 440<sup>b</sup> (Porter)  
   of Sidon . . . . . 2786<sup>a</sup> (Porter)  
 Beka . . . . . 427<sup>b</sup>  
   of Weights and Meas-  
   ures . . . . . 3079<sup>a</sup> (Porter)  
 Bel (Baal) . . . . . 427<sup>b</sup>  
   of Babylonia, Religion  
   of . . . . . 368<sup>b</sup> (Rogers)  
 Bel and the Dragon . . . . . 427<sup>b</sup> (T. W. Davies)  
   Author, place, date . . . . . 430<sup>b</sup>  
   Canonicity and au-  
   thenticity . . . . . 431<sup>a</sup>  
   of Daniel, Book of . . . . . 787<sup>b</sup> (R. D. Wilson)  
   Name . . . . . 428<sup>a</sup>  
   Original language . . . . . 429<sup>b</sup>  
   of Song of Three  
   Children . . . . . 2834<sup>a</sup> (T. W. Davies)  
   Story of Bel . . . . . 428<sup>a</sup>  
   Story of Dragon . . . . . 428<sup>b</sup>  
   cf Susanna, History  
   of . . . . . 2872<sup>b</sup> (T. W. Davies)  
   Teaching . . . . . 430<sup>b</sup>  
   Textual authorities . . . . . 429<sup>a</sup>  
 Bela  
   of Zoar . . . . . 3154<sup>a</sup> (Wright)

- Bela, Belah . . . . . 431<sup>b</sup> (Breslich)  
 Belaites . . . . . 431<sup>b</sup>  
 Belch . . . . . 431<sup>b</sup> (Kapp)  
 Belemus . . . . . 431<sup>b</sup>  
 Belial . . . . . 431<sup>b</sup> (Orr)  
   of Antichrist . . . . . 154<sup>a</sup> (J. E. H. Thomson)  
   of Man of Sin . . . . . 1976<sup>a</sup> (Orr)  
 Belie . . . . . 432<sup>a</sup>  
 Belief  
   of Faith . . . . . 1087<sup>b</sup> (Dunelm)  
 Believers . . . . . 432<sup>a</sup> (Rees)  
 Bell . . . . . 432<sup>a</sup> (Miller)  
 Bellows . . . . . 432<sup>a</sup>  
   of Crafts . . . . . 734<sup>a</sup> (Patch)  
   of Refiner, Refining . . . . . 2545<sup>a</sup> (Patch)  
 Belly . . . . . 432<sup>b</sup> (Hirsch)  
 Belmaim . . . . . 432<sup>b</sup>  
 Belmen, Belmon (Bel-  
   maim) . . . . . 432<sup>b</sup>  
 Belomancy  
   of Augury . . . . . 331<sup>a</sup> (T. W. Davies)  
 Beloved . . . . . 432<sup>b</sup> (Pratt)  
 Belshazzar . . . . . 433<sup>a</sup> (R. D. Wilson)  
   And Daniel . . . . . 783<sup>a</sup> (R. D. Wilson)  
   of Persians . . . . . 2336<sup>a</sup> (Tisdall)  
 Belt  
   of Armor . . . . . 254<sup>a</sup> (Nicol)  
 Beltshazzar . . . . . 433<sup>b</sup>  
 Belus, Temple of  
   of Babel . . . . . 350<sup>a</sup> (Pinches)  
 Ben (name) . . . . . 434<sup>a</sup>  
 Ben (prefix) . . . . . 433<sup>b</sup> (Breslich)  
   of Son, Sons . . . . . 2826<sup>a</sup> (Betteridge)  
 Ben-abinadab . . . . . 434<sup>a</sup>  
   of Abinadab . . . . . 12<sup>a</sup> (Beecher)  
 Benaiah . . . . . 434<sup>a</sup> (Breslich)  
   of Mamdai . . . . . 1972<sup>b</sup>  
   of Naidus . . . . . 2111<sup>a</sup>  
 Ben Ammi . . . . . 434<sup>b</sup> (Cohon)  
 Bench . . . . . 434<sup>b</sup> (Eager)  
   of Seat . . . . . 2710<sup>b</sup> (Cotton)  
 Ben-deker . . . . . 434<sup>b</sup>  
 Beneath . . . . . 434<sup>b</sup>  
 Bene-berak . . . . . 434<sup>b</sup>  
 Benediction . . . . . 434<sup>b</sup> (Kapp)  
   Apostolic benediction . . . . . 435<sup>a</sup>  
   of Blessing . . . . . 487<sup>b</sup> (Gray)  
   Family practice . . . . . 435<sup>a</sup>  
   Privilege of Aaronites . . . . . 435<sup>a</sup>  
   of Salutation . . . . . 2665<sup>a</sup> (Pollard)  
 Benefactor . . . . . 435<sup>b</sup> (Jacobs)  
 Benefit . . . . . 435<sup>b</sup> (Hirsch)  
 Bene-jaakan  
   of Beeroth Bene-  
   jaakan . . . . . 424<sup>b</sup>  
 Benevolence . . . . . 435<sup>b</sup>  
 Ben-geber . . . . . 435<sup>b</sup>  
   of Geber . . . . . 1180<sup>b</sup> (Downer)  
 Benhadad . . . . . 435<sup>b</sup> (Nicol); 779<sup>b</sup> (C. H.  
   Thomson)  
   Benhadad I . . . . . 436<sup>a</sup>  
   Benhadad—*continued*  
   Benhadad I—*continued*  
     Shortsightedness of  
       Asa . . . . . 436<sup>a</sup>  
       Syria founded . . . . . 436<sup>a</sup>  
       Syria and Judah . . . . . 436<sup>a</sup>  
     of Hadadezer (Had-  
       arezer) . . . . . 1314<sup>a</sup> (Nicol)  
     of Tabrimmon . . . . . 2902<sup>a</sup>  
   Benhadad II . . . . . 436<sup>a</sup>  
     Alliance with Ahab . . . . . 437<sup>a</sup>  
     Alliance broken off . . . . . 437<sup>a</sup>  
     And Elisha . . . . . 437<sup>a</sup>  
     Expeditions against  
       Israel . . . . . 436<sup>b</sup>  
     Monumental records . . . . . 437<sup>a</sup>  
     Murder of Ben-  
       hadad . . . . . 437<sup>b</sup>  
     Siege of Samaria . . . . . 437<sup>a</sup>  
   Benhadad III . . . . . 437<sup>b</sup>  
     Assyrians overcome  
       Syria . . . . . 437<sup>b</sup>  
     Contemporaries . . . . . 437<sup>b</sup>  
     Recuperation of  
       Israel . . . . . 437<sup>b</sup>  
   Ben-hail . . . . . 438<sup>a</sup>  
   Ben-hanan . . . . . 438<sup>a</sup>  
   Ben-hesed . . . . . 438<sup>a</sup>  
   Ben-hur . . . . . 438<sup>a</sup>  
   Beninu . . . . . 438<sup>a</sup>  
   Ben-jaakan (Bene-  
     jaakan) . . . . . 424<sup>b</sup>  
   Benjamin . . . . . 438<sup>a</sup> (Ewing)  
     The patriarch . . . . . 438<sup>a</sup>  
     Tribe . . . . . 438<sup>a</sup>  
       History . . . . . 438<sup>b</sup>  
       Number . . . . . 438<sup>a</sup>  
       Position . . . . . 438<sup>b</sup>  
       Territory . . . . . 438<sup>b</sup>  
   Benjamin, Gate of  
     of Jerusalem . . . . . 1603<sup>a</sup>  
   Benjamite . . . . . 439<sup>a</sup>  
   Beno . . . . . 439<sup>a</sup>  
   Ben-oni . . . . . 439<sup>a</sup>  
   Benzoheth . . . . . 439<sup>a</sup>  
     of Zoheth . . . . . 3155<sup>a</sup>  
 Beon  
   of Baal-meon . . . . . 347<sup>b</sup> (Ewing)  
 Beor . . . . . 439<sup>a</sup>  
 Bera . . . . . 439<sup>a</sup>  
 Beracah (person) . . . . . 439<sup>a</sup>  
 Beracah (valley) . . . . . 439<sup>a</sup> (Masterman)  
   of Jehoshaphat, Val-  
     ley of . . . . . 1583<sup>a</sup> (Masterman)  
 Berachiah (Berechiah) . . . . . 439<sup>b</sup>  
 Beraiah . . . . . 439<sup>a</sup>  
 Berea (Beroea) . . . . . 440<sup>a</sup> (Ewing)  
 Bereave, Bereaver, Bereft . . . . . 439<sup>a</sup> (Breslich)  
 Berechiah . . . . . 439<sup>a</sup>  
   of Zachariah . . . . . 3129<sup>a</sup>  
 Bered (person) . . . . . 439<sup>a</sup>; 421<sup>a</sup>  
 Bered (place) . . . . . 439<sup>b</sup> (Masterman)

- Berenice (Bernice) . . . . . 440<sup>a</sup> (Dosker)  
 Beri . . . . . 439<sup>b</sup>  
 Beriah, Beriites . . . . . 439<sup>b</sup>  
 Berites . . . . . 440<sup>a</sup>  
 Berith (Baal-berith) . . . . . 347<sup>a</sup>  
 Bernice . . . . . 440<sup>a</sup> (Dosker)  
 Berodach-Baladan  
   cf Baladan . . . . . 379<sup>b</sup> (R. D. Wilson)  
 Beroea . . . . . 440<sup>a</sup> (Ewing)  
 Beroth (Beeroth) . . . . . 424<sup>a</sup> (Ewing)  
 Berothah . . . . . 440<sup>b</sup> (C. H. Thomson)  
   cf Hethlon . . . . . 1384<sup>b</sup> (Christie)  
   cf Zobah . . . . . 3154<sup>b</sup> (Christie)  
 Berothite (Beerothite) . . . . . 424<sup>a</sup> (Ewing)  
 Berries . . . . . 440<sup>b</sup>  
 Beryl  
   cf Stones, Precious . . . . . 2856<sup>a</sup> (Fletcher)  
 Berytus . . . . . 440<sup>b</sup> (Porter)  
 Berzelus (Zorzelleus) . . . . . 3158<sup>b</sup>  
 Besai . . . . . 441<sup>a</sup>  
 Beset . . . . . 441<sup>a</sup> (Kapp)  
 Beside . . . . . 441<sup>a</sup> (Kapp)  
 Besiege  
   cf Siege . . . . . 2786<sup>a</sup> (Nicol)  
 Besodeiah . . . . . 441<sup>a</sup>  
 Besom . . . . . 441<sup>a</sup>  
 Besor, The Brook . . . . . 441<sup>a</sup>  
 Best . . . . . 441<sup>b</sup> (Pratt)  
 Bestead . . . . . 441<sup>b</sup>  
 Bestiality . . . . . 746<sup>a</sup> (Hirsch)  
 Bestow . . . . . 441<sup>b</sup>  
 Betah  
   cf Tibhath . . . . . 2980<sup>a</sup> (Christie)  
 Betane . . . . . 441<sup>b</sup>  
 Beten . . . . . 441<sup>b</sup>  
 Beth . . . . . 441<sup>b</sup>  
   cf Alphabet . . . . . 103<sup>b</sup> (Richardson)  
   cf Bayith . . . . . 416<sup>b</sup>  
 Beth (prefix) . . . . . 441<sup>b</sup> (Hirsch)  
 Bethabara . . . . . 442<sup>a</sup> (S. F. Hunter)  
   cf Bethany . . . . . 442<sup>b</sup> (Masterman)  
 Beth-anath . . . . . 442<sup>b</sup>  
 Beth-anoth . . . . . 442<sup>b</sup>  
 Bethany . . . . . 442<sup>b</sup> (Masterman)  
 Beth-arabah . . . . . 443<sup>a</sup>  
   cf Bethabara . . . . . 442<sup>a</sup> (S. F. Hunter)  
 Betharam (Beth-haram) . . . . . 446<sup>a</sup> (Ewing)  
 Beth-arbel . . . . . 443<sup>a</sup> (Ewing)  
   cf Arbela . . . . . 225<sup>b</sup> (Ewing)  
   cf Shalman . . . . . 2747<sup>b</sup> (Eiselen)  
 Bethasmoth . . . . . 443<sup>a</sup>  
   cf Azmaveth . . . . . 345<sup>a</sup>  
 Beth-aven . . . . . 443<sup>a</sup>  
 Beth-azmaveth (Azmaveth) . . . . . 345<sup>a</sup>  
 Beth-baal-meon (Baal-meon) . . . . . 347<sup>b</sup> (Ewing)  
 Beth-barah . . . . . 443<sup>a</sup> (S. F. Hunter)  
   cf Bethabara . . . . . 442<sup>a</sup> (S. F. Hunter)  
 Bethbasi . . . . . 443<sup>b</sup> (S. F. Hunter)  
 Beth-biri . . . . . 443<sup>b</sup>  
 Beth-car . . . . . 443<sup>b</sup> (Masterman)  
   cf Beth-haccherem . . . . . 445<sup>b</sup> (Masterman)  
 Beth-dagon . . . . . 443<sup>b</sup> (Ewing)  
 Beth-diblathaim . . . . . 443<sup>b</sup>  
   cf Moabite Stone . . . . . 2071<sup>b</sup> (Sayce)  
 Beth-eden  
   cf Eden . . . . . 897<sup>b</sup> (Wright)  
 Bethel . . . . . 443<sup>b</sup> (Ewing)  
   cf Almond . . . . . 100<sup>a</sup> (Masterman)  
   History . . . . . 444<sup>a</sup>  
   cf House of God . . . . . 1438<sup>a</sup> (Orr)  
   Name and location . . . . . 443<sup>b</sup>  
   Sanctuary . . . . . 444<sup>a</sup>  
 Bethelite . . . . . 444<sup>b</sup>  
   cf Hiel . . . . . 1389<sup>a</sup> (Stearns)  
 Bethel, Mount . . . . . 444<sup>b</sup>  
 Beth-emek . . . . . 444<sup>b</sup>  
 Bether . . . . . 444<sup>b</sup> (Orr)  
   cf Malobathron . . . . . 1972<sup>b</sup>  
 Bethesda . . . . . 444<sup>b</sup> (Masterman)  
   cf Gihon . . . . . 1228<sup>b</sup> (Masterman)  
   cf Jerusalem . . . . . 1597<sup>b</sup> (Masterman); 1608<sup>b</sup>  
   (Masterman)  
   cf Jesus Christ . . . . . 1641<sup>b</sup> (Orr)  
   cf Sheep Gate . . . . . 2758<sup>a</sup>  
   cf Sheep Market . . . . . 2758<sup>a</sup>  
 Beth-ezel . . . . . 445<sup>b</sup>  
   cf Azel . . . . . 344<sup>b</sup>  
 Beth-gader . . . . . 445<sup>b</sup>  
 Beth-gamul . . . . . 445<sup>b</sup>  
 Beth-gilgal . . . . . 445<sup>b</sup>  
   cf Gallim . . . . . 1167<sup>b</sup> (Masterman)  
 Beth-haccherem . . . . . 445<sup>b</sup> (Masterman)  
   cf Beth-car . . . . . 443<sup>b</sup> (Masterman)  
 Beth-haggan . . . . . 445<sup>b</sup>  
   cf Garden-house . . . . . 1175<sup>a</sup>  
 Beth-hanan, Elon-beth-hanan  
   cf Elon . . . . . 939<sup>a</sup>  
 Beth-haram . . . . . 446<sup>a</sup> (Ewing)  
 Beth-haran . . . . . 446<sup>a</sup>  
 Beth-hoglah . . . . . 446<sup>a</sup> (Wright)  
   cf Dead Sea . . . . . 801<sup>a</sup> (Wright)  
 Beth-horon . . . . . 446<sup>a</sup> (Masterman)  
   Ancient and modern  
   towns . . . . . 446<sup>a</sup>  
   cf Jashar, Book of . . . . . 1570<sup>a</sup> (Orr)  
   cf Judah, Territory  
   of . . . . . 1763<sup>a</sup> (Masterman)  
   Pass of the Beth-horons . . . . . 446<sup>b</sup>  
 Beth-horon, Battle of . . . . . 446<sup>b</sup> (Maunder)  
   Astronomical relations . . . . . 448<sup>a</sup>  
   Moon stayed . . . . . 448<sup>a</sup>  
   Sun was silent . . . . . 448<sup>a</sup>  
   Book of Jashar . . . . . 448<sup>a</sup>  
   Chronicle and poem  
   compared . . . . . 448<sup>b</sup>  
   Date of events . . . . . 449<sup>a</sup>  
   Jehovah fought for  
   Israel . . . . . 448<sup>b</sup>

- Beth-horon, Battle of—*continued*  
 Joshua and the Hivites 446<sup>b</sup>  
 Joshua's strategy . . . . . 447<sup>a</sup>
- Bethink . . . . . 449<sup>a</sup>
- Beth-jeshimoth . . . . . 449<sup>b</sup> (Ewing)
- Beth-le-'aphrah . . . . . 449<sup>b</sup> (Porter)
- Beth-lebaoth . . . . . 449<sup>b</sup>  
 cf Beth-biri . . . . . 443<sup>b</sup>  
 cf Lebaoth . . . . . 1864<sup>a</sup>
- Bethlehem . . . . . 449<sup>b</sup> (Masterman)  
 Bethlehem Judah . . . . . 449<sup>b</sup>  
 Christian era . . . . . 450<sup>a</sup>  
 David the Bethle-  
 hemite . . . . . 450<sup>a</sup>  
 Early history . . . . . 449<sup>b</sup>  
 cf Ephrath . . . . . 964<sup>a</sup> (Masterman)  
 Later Bible history . 450<sup>a</sup>  
 Bethlehem of Zebulun 450<sup>a</sup>  
 cf Jesus Christ . . . . . 1632<sup>b</sup> (Orr)  
 cf Joseph, Husband of  
 Mary . . . . . 1741<sup>a</sup> (Kerr)
- Bethlehem, Star of  
 cf Jesus Christ . . . . . 1633<sup>a</sup> (Orr)  
 cf Star of the Magi . . 2848<sup>a</sup> (Maunder)
- Bethlehemite . . . . . 450<sup>b</sup>
- Beth-lomon . . . . . 450<sup>b</sup>
- Beth-maacah (Abel-  
 beth-maacah) . . . . . 5<sup>b</sup> (Beecher)
- Beth-marcaboth . . . . . 450<sup>b</sup> (Masterman)
- Beth-meon . . . . . 450<sup>b</sup>
- Beth-merhak . . . . . 450<sup>b</sup>
- Beth-milcah (Milcah) . . 2051<sup>a</sup>
- Beth-millo (Millo) . . . . 2055<sup>a</sup> (Masterman)
- Beth-nimrah . . . . . 450<sup>b</sup> (Wright)  
 cf Leopard . . . . . 1866<sup>b</sup> (Day)  
 cf Nimrah . . . . . 2147<sup>a</sup> (Ewing)
- Beth-palet (Beth-pelet) . 450<sup>b</sup>
- Beth-pazzez . . . . . 450<sup>b</sup>
- Beth-pelet . . . . . 450<sup>b</sup>
- Beth-peor . . . . . 451<sup>a</sup> (Ewing)
- Bethphage . . . . . 451<sup>a</sup> (Masterman)  
 cf Olives, Mount of . . 2185<sup>b</sup> (Masterman)
- Beth-phelet (Beth-pelet) 450<sup>b</sup>
- Beth-rapha . . . . . 451<sup>a</sup>
- Beth-rehob . . . . . 451<sup>b</sup> (C. H. Thomson)
- Bethsaida . . . . . 451<sup>b</sup> (Ewing)  
 Of Galilee . . . . . 451<sup>b</sup>  
 Julius . . . . . 452<sup>a</sup>  
 Were there two? . . . . 452<sup>a</sup>
- Bethsamos (Bethasmoth) 443<sup>a</sup>
- Beth-shean, Beth-shan . . 452<sup>b</sup> (Ewing)
- Beth-shemesh . . . . . 453<sup>a</sup> (Kyle)  
 In Egypt . . . . . 453<sup>b</sup>  
 cf Ir-shemesh . . . . . 1493<sup>a</sup>  
 Of Issachar . . . . . 453<sup>a</sup>  
 Of Judah . . . . . 453<sup>a</sup>  
 Of Naphtali . . . . . 453<sup>b</sup>  
 cf Sun-worship . . . . . 2870<sup>b</sup> (Orr)
- Beth-shemite . . . . . 453<sup>b</sup>
- Beth-shittah . . . . . 453<sup>b</sup>
- Bethsura, Bethsuron . . . 453<sup>b</sup>
- Beth-tappuah . . . . . 453<sup>b</sup> (Masterman)
- Bethuel (person) . . . . . 453<sup>b</sup> (Hirsch)
- Bethuel (place) . . . . . 454<sup>a</sup>
- Bethul  
 cf Bethuel . . . . . 454<sup>a</sup>  
 cf Chesil . . . . . 605<sup>a</sup>
- Bethulia . . . . . 454<sup>a</sup> (Ewing)
- Beth-zacharias . . . . . 454<sup>a</sup>
- Beth-zur . . . . . 454<sup>a</sup> (Masterman)  
 cf Jerusalem . . . . . 1613<sup>b</sup> (Masterman)  
 cf Judah, Territory of 1763<sup>a</sup> (Masterman)
- Betimes . . . . . 454<sup>a</sup> (Kinsella)  
 cf Morning . . . . . 2082<sup>b</sup> (Porter)
- Betolion . . . . . 454<sup>b</sup>
- Betomesthaim, Betomas-  
 thaim . . . . . 454<sup>b</sup>
- Betonim . . . . . 454<sup>b</sup>
- Betray . . . . . 454<sup>b</sup> (Rees)
- Betrayers . . . . . 454<sup>b</sup>
- Betroth . . . . . 454<sup>b</sup>
- Betrothal  
 cf Marriage . . . . . 1997<sup>b</sup> (Eager)
- Between the Testaments . 455<sup>a</sup> (Dosker)  
 Contemporaneous his-  
 tory . . . . . 455<sup>a</sup>  
 Asia . . . . . 455<sup>b</sup>  
 Egypt . . . . . 455<sup>a</sup>  
 Greece . . . . . 455<sup>b</sup>  
 Rome . . . . . 455<sup>b</sup>
- Historical develop-  
 ments . . . . . 455<sup>b</sup>  
 Alexandrian period . 456<sup>a</sup>  
 Egyptian period . . . 456<sup>b</sup>  
 Maccabean period . . 457<sup>a</sup>  
 Persian period . . . . 456<sup>a</sup>  
 Roman period . . . . . 457<sup>a</sup>  
 Syrian period . . . . . 456<sup>b</sup>
- Internal developments . 457<sup>a</sup>  
 Literary activity . . . 457<sup>b</sup>  
 Parties . . . . . 458<sup>a</sup>
- Preparation for  
 Christianity . . . . . 458<sup>b</sup>  
 Spiritual conditions . 458<sup>a</sup>
- cf Maccabaeus, Mac-  
 cabees . . . . . 1946<sup>a</sup> (Hutchison)
- Period in general . . . . 455<sup>a</sup>
- Beulah . . . . . 458<sup>b</sup>
- Bewail . . . . . 458<sup>b</sup>  
 cf Grief . . . . . 1305<sup>b</sup> (W. L. Walker)
- Bewitch . . . . . 458<sup>b</sup> (Kapp)  
 cf Divination . . . . . 860<sup>a</sup> (T. W. Davies)  
 cf Evil Eye . . . . . 1042<sup>b</sup> (Luering)  
 cf Magic . . . . . 1963<sup>a</sup> (T. W. Davies)  
 cf Superstition . . . . . 2871<sup>a</sup> (Doolan)
- Bewray, Bewrayer . . . . 459<sup>a</sup> (Kinsella)
- Beyond . . . . . 459<sup>a</sup> (Hirsch)
- Bezaanannim (Zaanan-  
 nim) . . . . . 3128<sup>a</sup> (Ewing)
- Bezai . . . . . 459<sup>b</sup>
- Bezalel . . . . . 459<sup>b</sup> (Farr)  
 cf Sesthel . . . . . 2743<sup>a</sup>
- Bezek . . . . . 459<sup>b</sup>

- Bezer . . . . . 459<sup>b</sup>  
   cf Refuge, Cities of . 254<sup>b</sup> (Ewing)  
 Bezeth . . . . . 459<sup>b</sup>  
   cf Jerusalem . . . . . 159<sup>b</sup> (Masterman)  
 Bezetha . . . . . 459<sup>b</sup>  
   cf Jerusalem . . . . . 160<sup>b</sup> (Masterman)  
 Biatas . . . . . 459<sup>b</sup>  
   cf Phalias . . . . . 235<sup>b</sup>  
 Bible, The . . . . . 459<sup>b</sup> (Orr)  
   Authorized and Revised  
     Versions . . . . . 469<sup>a</sup>  
     cf American Revised  
       Version . . . . . 116<sup>a</sup> (Easton)  
   Compass and divisions . 461<sup>a</sup>  
     Apocrypha . . . . . 462<sup>a</sup>  
     Hebrew OT—Josephus . . . . . 461<sup>a</sup>  
     NT . . . . . 462<sup>b</sup>  
       cf Canon of NT . 563<sup>a</sup> (Riggs)  
     Septuagint . . . . . 461<sup>b</sup>  
     Vulgate . . . . . 462<sup>a</sup>  
       cf Vulgate . . . . . 305<sup>b</sup> (Angus)  
   cf Gospels, Synoptic . 1281<sup>b</sup> (Iverach)  
   Languages . . . . . 460<sup>b</sup>  
     Of NT . . . . . 460<sup>b</sup>  
     Of OT . . . . . 460<sup>b</sup>  
   Literary origin of NT . 465<sup>b</sup>  
     Canonicity . . . . . 467<sup>b</sup>  
       cf Canon of NT . 563<sup>a</sup> (Riggs)  
     Epistles . . . . . 466<sup>a</sup>  
       cf Captivity Ep . 466<sup>b</sup> (Orr)  
       cf Catholic Ep . 467<sup>a</sup> (Orr)  
       cf Pastoral Ep . 225<sup>b</sup> (Rutherford)  
     Gospels and Acts . 465<sup>b</sup>  
     Prophecy . . . . . 467<sup>a</sup>  
       cf Apocalyptic  
         Literature . . . . . 161<sup>b</sup> (J. E. H. Thomson)  
   Literary origin of OT  
     Age of David and  
       Solomon . . . . . 463<sup>a</sup>  
     Canonicity . . . . . 462<sup>b</sup>  
       cf Canon of OT . 554<sup>a</sup> (Robinson)  
     Daniel . . . . . 464<sup>a</sup>  
     Exilian and post-  
       exilian periods . 464<sup>a</sup>  
     Josiah's reformation . 464<sup>a</sup>  
     Judges . . . . . 463<sup>a</sup>  
     Mosaic age . . . . . 463<sup>a</sup>  
     Newer criticism . . 464<sup>a</sup>  
     Patriarchal age . . 463<sup>a</sup>  
     Prophecy . . . . . 463<sup>b</sup>  
     Wisdom literature . 463<sup>b</sup>  
   Names . . . . . 460<sup>a</sup>  
     Bible . . . . . 460<sup>a</sup>  
     NT . . . . . 460<sup>b</sup>  
     OT . . . . . 460<sup>b</sup>  
     Other designations . 460<sup>b</sup>  
     cf Revised Versions . 951<sup>b</sup> (Hutchison)  
       Authorized . . . . . 950<sup>b</sup>  
       English . . . . . 945<sup>b</sup>  
   cf Scripture . . . . . 2706<sup>a</sup>
- Bible, The—*continued*  
   Unity and spiritual  
     purpose—inspiration . 467<sup>b</sup>  
     Historical influence . 468<sup>b</sup>  
       cf Versions, Geor-  
         gian, Gothic,  
         Slavonic . . . . . 3048<sup>a</sup> (Easton)  
     Inspiration . . . . . 468<sup>a</sup>  
       cf Inspiration . . 1473<sup>a</sup> (Warfield)  
     Purpose of grace . . 468<sup>a</sup>  
     Unity . . . . . 467<sup>b</sup>  
 Bible, Criticism of . . . . 748<sup>b</sup> (Orr)  
 Bible, The Geneva . . . . . 949<sup>b</sup> (Hutchison)  
 Bible, The Great . . . . . 949<sup>a</sup> (Hutchison)  
 Biblical Discrepancies . . 852<sup>b</sup> (Van Pelt)  
 Biblical Mythology . . . . 231<sup>a</sup> (Kyle)  
 Biblical Theology . . . . . 469<sup>b</sup> (J. Lindsay)  
   Divisions . . . . . 471<sup>b</sup>  
   Divergent views on  
     OT . . . . . 471<sup>b</sup>  
     Law and prophecy . 472<sup>a</sup>  
     Mosaism, place of . 472<sup>a</sup>  
     Prophetism and Ju-  
       daism . . . . . 472<sup>a</sup>  
     Religious develop-  
       ment of Israel . . 472<sup>a</sup>  
   History . . . . . 470<sup>a</sup>  
     Effect of criticism . 471<sup>b</sup>  
     NT theology, 19th  
       century . . . . . 470<sup>b</sup>  
     OT theology in later  
       centuries . . . . . 470<sup>a</sup>  
     Patristic and scho-  
       lastic periods . . 470<sup>a</sup>  
     Scientific develop-  
       ment . . . . . 470<sup>a</sup>  
     Science . . . . . 469<sup>b</sup>  
     Place and methods . 470<sup>a</sup>  
     Relation to dog-  
       matics . . . . . 469<sup>b</sup>  
 Bichri . . . . . 472<sup>b</sup>  
 Bid . . . . . 472<sup>b</sup>  
 Bidden . . . . . 472<sup>b</sup>  
 Bide . . . . . 472<sup>b</sup>  
 Bidkar . . . . . 472<sup>b</sup>  
 Bier . . . . . 472<sup>b</sup> (Eager)  
 Bigtha . . . . . 473<sup>a</sup>  
 Bigthan, Bigthana . . . 473<sup>a</sup>  
 Bigvai . . . . . 473<sup>a</sup>  
 Bikath-aven . . . . . 473<sup>a</sup>  
   cf Aven . . . . . 340<sup>a</sup>  
   cf Eden . . . . . 897<sup>b</sup> (Wright)  
 Bildad . . . . . 473<sup>b</sup> (Genung)  
   cf Shua, Shuah . . . . 2781<sup>a</sup>  
   cf Shuhite . . . . . 2781<sup>b</sup>  
   cf Zophar . . . . . 3156<sup>b</sup> (Genung)  
 Bileam . . . . . 473<sup>b</sup>  
   cf Ibleam . . . . . 1446<sup>a</sup> (Ewing)  
 Bilgah, Bilgai . . . . . 473<sup>b</sup>  
 Bilhah (person) . . . . . 474<sup>a</sup>  
 Bilhah (place) . . . . . 474<sup>a</sup>  
 Bilhan . . . . . 474<sup>a</sup>



- Bill, Bond . . . . . 474<sup>a</sup> (Eager)  
 Bill of Divorcement  
   cf Divorce in OT . . . . . 863<sup>b</sup> (W. W. Davies)  
 Billow . . . . . 464<sup>b</sup>  
 Bilshan . . . . . 474<sup>b</sup> (Wolf)  
 Bimhal . . . . . 474<sup>b</sup>  
 Bind, Bound . . . . . 474<sup>b</sup> (Kapp)  
   cf Authority . . . . . 333<sup>a</sup> (Rees)  
   cf Forgiveness . . . . . 1132<sup>b</sup> (Morro)  
   cf Peter, Simon . . . . . 2348<sup>b</sup> (Gray)  
 Binea . . . . . 474<sup>b</sup>  
 Binnui . . . . . 474<sup>b</sup> (Wolf)  
 Bird-catcher  
   cf Fowler . . . . . 1143<sup>a</sup> (Stratton-Porter)  
 Birds . . . . . 475<sup>a</sup> (Stratton-Porter)  
   cf Abomination, Birds  
     of . . . . . 16<sup>a</sup> (Stratton-Porter)  
   Of Bible . . . . . 476<sup>a</sup>  
     Early mention . . . . . 476<sup>a</sup>  
     Sacrifice . . . . . 476<sup>b</sup>  
   Meaning of word . . . . . 475<sup>a</sup>  
   Natural history . . . . . 475<sup>a</sup>  
     Earliest traces . . . . . 475<sup>a</sup>  
     Food, blood, etc. . . . . 476<sup>a</sup>  
     Structure . . . . . 475<sup>a</sup>  
   Of prey . . . . . 477<sup>a</sup> (Stratton-Porter)  
   Unclean . . . . . 16<sup>b</sup> (Stratton-Porter); 477<sup>b</sup>  
     (Reeve)  
 Birsha . . . . . 477<sup>b</sup>  
 Birth . . . . . 477<sup>b</sup> (Eager)  
   cf Jesus Christ . . . . . 1632<sup>b</sup> (Orr)  
   cf Travail . . . . . 3007<sup>a</sup> (Macalister)  
   cf Virgin-birth . . . . . 3052<sup>a</sup> (Sweet)  
 Birth, New  
   cf Regeneration . . . . . 2546<sup>b</sup> (Nuelsen)  
 Birth, Virgin . . . . . 3052<sup>a</sup> (Sweet)  
 Birthday . . . . . 478<sup>a</sup> (Eager)  
   cf Calendar . . . . . 541<sup>b</sup> (Porter)  
   cf Jesus Christ . . . . . 1632<sup>a</sup> (Orr)  
 Birthright . . . . . 478<sup>a</sup> (J. M. Wilson)  
   cf Family . . . . . 1094<sup>b</sup> (Caverno)  
   cf First-born . . . . . 1113<sup>b</sup> (T. Lewis)  
   cf Heir . . . . . 1369<sup>a</sup> (Easton)  
   cf Inheritance . . . . . 1468<sup>b</sup> (Hirsch)  
   cf Isaac . . . . . 1494<sup>a</sup> (Boyd)  
   cf Patrimony . . . . . 2264<sup>a</sup> (Mack)  
   cf Primogeniture . . . . . 2452<sup>b</sup> (N. Isaacs)  
 Birth-stool . . . . . 478<sup>b</sup>  
   cf Stool . . . . . 2862<sup>b</sup> (Cotton)  
 Birzaith . . . . . 478<sup>b</sup>  
 Bishlam . . . . . 478<sup>b</sup>  
 Bishop (general) . . . . . 478<sup>b</sup> (Dosker)  
   Later developments . . . . . 479<sup>a</sup>  
   cf Ministry . . . . . 2059<sup>b</sup> (T. M. Lindsay)  
   cf Overseer . . . . . 2205<sup>b</sup>  
   cf Presbyter . . . . . 2437<sup>b</sup> (Mack)  
   Use in NT . . . . . 479<sup>a</sup>  
   Use in Septuagint and  
     classic Greek . . . . . 478<sup>b</sup>  
 Bishop (Anglican view) . . . . . 479<sup>b</sup> (Lowndes)  
   Bishops and deacons . . . . . 481<sup>b</sup>  
   Bishops and presbyters . . . . . 481<sup>b</sup>
- Bishop (Anglican view)—*continued*  
   Clement of Rome . . . . . 481<sup>a</sup>  
   Didache . . . . . 481<sup>a</sup>  
   Early church officers . . . . . 479<sup>b</sup>  
     Apostles . . . . . 479<sup>b</sup>  
     Bishops . . . . . 480<sup>a</sup>  
     Deacons . . . . . 480<sup>b</sup>  
     Elders or presbyters . . . . . 480<sup>a</sup>  
     Evangelists . . . . . 480<sup>a</sup>  
     Prophets . . . . . 479<sup>b</sup>  
     Teachers . . . . . 480<sup>a</sup>  
   Episcopacy, definition  
     of . . . . . 479<sup>b</sup>  
     Of NT . . . . . 480<sup>b</sup>  
   Ignatian Ep. . . . . 481<sup>b</sup>  
   Reformation . . . . . 481<sup>b</sup>  
 Bishop (Congregational  
   view) . . . . . 482<sup>b</sup> (Pratt)  
   Election . . . . . 482<sup>a</sup>  
   NT church . . . . . 482<sup>a</sup>  
   Restoration of primi-  
     tive ideals . . . . . 482<sup>b</sup>  
 Bishoprick . . . . . 482<sup>b</sup>; 478<sup>b</sup> (Dosker)  
 Bishops' Bible  
   cf English Versions . . . . . 945<sup>b</sup> (Hutchison)  
 Bismaya  
   cf Shinar . . . . . 2771<sup>b</sup> (Pinches)  
 Bit and Bridle . . . . . 482<sup>b</sup> (W. L. Walker)  
 Bithiah . . . . . 483<sup>a</sup> (Hirsch)  
   cf Mered . . . . . 2036<sup>a</sup> (Wallace)  
 Bithron . . . . . 483<sup>a</sup>  
 Bithynia . . . . . 483<sup>a</sup> (White)  
   cf Haven . . . . . 1344<sup>b</sup> (Day)  
   cf Pontus . . . . . 2418<sup>a</sup> (White)  
 Bithynian Immigrations  
   to Asia Minor . . . . . 274<sup>b</sup> (Calder)  
 Bitter, Bitterness . . . . . 483<sup>b</sup> (Hirsch)  
 Bitter Herbs . . . . . 484<sup>a</sup> (Masterman)  
   cf Herb . . . . . 1375<sup>a</sup> (Masterman)  
 Bittren . . . . . 484<sup>a</sup> (Stratton-Porter)  
   cf Hedgehog . . . . . 1367<sup>a</sup>  
   cf Porcupine . . . . . 2421<sup>b</sup> (Day)  
   cf Serpent . . . . . 2738<sup>a</sup> (Day)  
 Bitterness . . . . . 483<sup>b</sup> (Hirsch)  
 Bitterness, Water of  
   cf Adultery . . . . . 63<sup>a</sup> (Margolis)  
 Bitter Water  
   cf Adultery . . . . . 63<sup>a</sup> (Margolis)  
   cf Marah . . . . . 1984<sup>b</sup>  
 Bitumen  
   cf Mortar . . . . . 2083<sup>a</sup> (Orr)  
   cf Slime . . . . . 2817<sup>b</sup> (Day)  
 Biziothiah . . . . . 485<sup>a</sup>  
 Biztha . . . . . 485<sup>a</sup>  
 Black  
   cf Colors . . . . . 674<sup>b</sup> (Patch)  
 Blackness . . . . . 485<sup>a</sup> (Pratt)  
 Black Obelisk  
   cf Jehu . . . . . 1586<sup>a</sup> (Caldecott)  
 Blains . . . . . 485<sup>b</sup> (Macalister)  
 Blasphemy . . . . . 485<sup>b</sup> (Rees)  
   cf Forgiveness . . . . . 1132<sup>b</sup> (Morro)

- Blasphemy—*continued*  
 cf Holy Spirit . . . . . 1406<sup>a</sup> (Mullins)  
 cf Jesus Christ . . . . . 1644<sup>b</sup>  
 Unpardonable sin . . . . . 485<sup>b</sup>
- Blast . . . . . 486<sup>a</sup> (M. O. Evans)  
 Blast, Blasting . . . . . 486<sup>a</sup> (Patch)  
 cf Agriculture . . . . . 77<sup>a</sup> (Patch)  
 cf Mildew . . . . . 2051<sup>b</sup> (Masterman)
- Blastus . . . . . 486<sup>b</sup> (S. F. Hunter)  
 Blaze . . . . . 486<sup>b</sup>  
 Blemish . . . . . 486<sup>b</sup> (Luering)  
 cf Spot, Spotted . . . . . 2846<sup>b</sup> (Macalister)
- Bless . . . . . 487<sup>a</sup> (Gray)  
 cf Benediction . . . . . 434<sup>b</sup> (Kapp)
- Blessed . . . . . 487<sup>a</sup> (Gray)  
 cf Beatitudes . . . . . 419<sup>a</sup> (Lambert)
- Blessedness . . . . . 487<sup>a</sup> (Gray)  
 Blessing . . . . . 487<sup>b</sup> (Gray)  
 cf Heredity . . . . . 1376<sup>a</sup> (Easton)  
 cf Priests and Levites 2452<sup>b</sup> (Wiener)
- Blessing, Cup of . . . . . 487<sup>b</sup>  
 cf Cup . . . . . 766<sup>a</sup> (Jacobs)
- Blessing, Valley of  
 cf Beracah . . . . . 439<sup>a</sup> (Masterman)
- Blindfold . . . . . 487<sup>b</sup>  
 Blinding  
 cf Punishments . . . . . 2504<sup>b</sup> (Hirsch)
- Blindness . . . . . 487<sup>b</sup> (Macalister)  
 cf Tender . . . . . 2947<sup>a</sup> (Easton)
- Blindness, Judicial . . . . . 488<sup>a</sup> (T. Lewis)  
 Blood . . . . . 488<sup>b</sup> (Clippinger)  
 Hebrew and OT cus-  
 toms . . . . . 489<sup>a</sup>  
 cf Circumcision . . . . . 656<sup>b</sup> (T. Lewis)  
 cf Purity . . . . . 2507<sup>b</sup> (Caverno)  
 NT teachings . . . . . 489<sup>a</sup>  
 cf Atonement . . . . . 627<sup>b</sup> (Orr)  
 Primitive ideas . . . . . 488<sup>b</sup>  
 cf Revenge, Re-  
 venger . . . . . 2587<sup>a</sup> (Breslich)  
 cf Wine . . . . . 3086<sup>a</sup> (Easton)
- Blood and Water . . . . . 489<sup>a</sup> (Luering)  
 cf Jesus Christ . . . . . 1663<sup>b</sup> (Orr)  
 Physiological expla-  
 nation . . . . . 489<sup>b</sup>
- Blood, Avenger of  
 cf Avenger . . . . . 340<sup>a</sup> (Breslich)
- Bloodguiltiness . . . . . 490<sup>a</sup>  
 Blood, Issue of  
 cf Bloody Flux . . . . . 490<sup>b</sup> (Macalister)
- Blood Revenge  
 cf Avenger . . . . . 340<sup>a</sup> (Breslich)
- Bloodshedding . . . . . 490<sup>a</sup>  
 Bloodthirsty . . . . . 490<sup>a</sup>  
 Bloody . . . . . 490<sup>a</sup> (M. O. Evans)  
 Bloody Flux . . . . . 490<sup>b</sup> (Macalister)  
 Bloody Sweat . . . . . 490<sup>b</sup> (Macalister)
- Bloom, Blossom  
 cf Flowers . . . . . 1120<sup>b</sup> (Masterman)
- Blot . . . . . 490<sup>b</sup> (Kaiser)  
 cf Book of Life . . . . . 503<sup>a</sup> (Kaiser)  
 cf Book of Remem-  
 brance . . . . . 503<sup>b</sup>  
 cf Forgiveness . . . . . 1132<sup>b</sup> (Morro)
- Blow . . . . . 490<sup>b</sup> (Hirsch)
- Blue  
 cf Colors . . . . . 674<sup>b</sup> (Patch)
- Boanerges . . . . . 491<sup>a</sup> (Kerr)  
 cf James, Son of Zebe-  
 dee . . . . . 1560<sup>a</sup> (Kerr)
- Boar . . . . . 491<sup>a</sup> (Day)  
 cf Swine . . . . . 2875<sup>b</sup> (Day)
- Board . . . . . 491<sup>a</sup> (Hirsch)  
 Boast . . . . . 491<sup>a</sup>  
 Boat  
 cf Ships and Boats . . . . . 2774<sup>a</sup> (Nicol)
- Boaz . . . . . 491<sup>a</sup> (Roberts)  
 And Jachin . . . . . 1547<sup>b</sup> (Caldecott)  
 cf Jesse . . . . . 1623<sup>a</sup> (Roberts)  
 cf Temple . . . . . 2932<sup>a</sup> (Caldecott; Orr)
- Boccas . . . . . 491<sup>b</sup>  
 Bocheru . . . . . 491<sup>b</sup>  
 Bochim . . . . . 491<sup>b</sup>  
 Body . . . . . 491<sup>b</sup> (Hirsch; Marais;  
 Pratt)  
 Figurative . . . . . 493<sup>a</sup> (Pratt)  
 General . . . . . 492<sup>a</sup> (Marais)  
 Body and sin . . . . . 492<sup>b</sup>  
 First sin . . . . . 492<sup>b</sup>  
 NT references . . . . . 492<sup>a</sup>  
 OT references . . . . . 492<sup>a</sup>  
 Other meanings . . . . . 492<sup>a</sup>  
 cf Member . . . . . 2030<sup>a</sup> (Luering)  
 Philological . . . . . 491<sup>b</sup> (Hirsch)  
 cf Resurrection . . . . . 2562<sup>a</sup> (Easton)  
 cf Spiritual Body . . . . . 2843<sup>a</sup>
- Body of Death . . . . . 493<sup>a</sup> (Dosker)  
 Bodyguard . . . . . 493<sup>a</sup>  
 Body of Heaven . . . . . 493<sup>b</sup>  
 Body, Spiritual . . . . . 493<sup>b</sup> (Morro)  
 cf Psychology . . . . . 2494<sup>b</sup> (Marais)
- Bohan . . . . . 494<sup>a</sup>  
 Boil (noun) . . . . . 494<sup>a</sup> (Macalister)  
 cf Plagues of Egypt . . . . . 2405<sup>a</sup> (Kyle)
- Boil (verb) . . . . . 494<sup>a</sup> (W. L. Walker)  
 Boldness . . . . . 494<sup>b</sup> (Kapp)  
 Bolled . . . . . 494<sup>b</sup>  
 Bolster . . . . . 494<sup>b</sup> (Eager)  
 Bolt . . . . . 494<sup>b</sup> (M. O. Evans)
- Bond  
 cf Band . . . . . 382<sup>a</sup> (Nicol; Rees)  
 cf Bill, Bond . . . . . 474<sup>a</sup> (Eager)  
 cf Chain . . . . . 589<sup>a</sup> (Fortune)
- Bondage . . . . . 494<sup>b</sup> (McGlothlin)  
 cf Slavery . . . . . 2815<sup>a</sup> (Raffety)
- Bondmaid . . . . . 495<sup>a</sup> (McGlothlin)  
 cf Slavery . . . . . 2815<sup>a</sup> (Raffety)
- Bondman . . . . . 495<sup>a</sup> (McGlothlin)  
 Bondservant . . . . . 495<sup>a</sup>  
 Bone, Bones . . . . . 495<sup>b</sup> (Luering)

- Bonnet . . . . . 495<sup>b</sup>  
 cf Dress . . . . . 875<sup>b</sup> (Eager)  
 cf Mitre . . . . . 2067<sup>b</sup> (T. Lewis)  
 Book . . . . . 495<sup>b</sup> (Richardson)  
 Book collections . . . . . 502<sup>b</sup>  
 Definitions . . . . . 496<sup>a</sup>  
 Early history in Bible  
 lands . . . . . 503<sup>a</sup>  
 Higher criticism . . . . . 500<sup>b</sup>  
 Inward books . . . . . 496<sup>b</sup>  
 cf Libraries . . . . . 1882<sup>a</sup> (Richardson)  
 Literary criticism . . . . . 500<sup>b</sup>  
 Manuscripts . . . . . 498<sup>a</sup>; 1984<sup>a</sup> (Richardson)  
 Diplomatics . . . . . 498<sup>b</sup>  
 Epigraphy . . . . . 498<sup>b</sup>  
 cf Alphabet . . . . . 103<sup>b</sup> (Richardson)  
 cf Table . . . . . 2898<sup>a</sup> (Easton)  
 cf Weight . . . . . 3079<sup>a</sup> (Porter)  
 cf Writing . . . . . 3114<sup>a</sup> (Richardson)  
 Numismatics . . . . . 498<sup>b</sup>  
 cf Money . . . . . 2076<sup>a</sup> (Porter)  
 Oral transmission . . . . . 497<sup>b</sup>  
 Part played in OT . . . . . 498<sup>a</sup>  
 Vedas . . . . . 497<sup>b</sup>  
 Origin of new forms . . . . . 501<sup>a</sup>  
 Paleography . . . . . 498<sup>b</sup>  
 cf Print . . . . . 2455<sup>a</sup> (Richardson)  
 Printed books . . . . . 499<sup>a</sup>  
 Publication . . . . . 496<sup>b</sup>  
 Mechanical copies . . . . . 497<sup>a</sup>  
 Personal copies . . . . . 497<sup>b</sup>  
 Survival . . . . . 501<sup>b</sup>  
 Textual criticisms . . . . . 500<sup>a</sup>  
 cf Text of NT . . . . . 2950<sup>b</sup> (Sitterly)  
 cf Text of OT . . . . . 2957<sup>b</sup> (Weir)  
 Variations . . . . . 499<sup>b</sup>  
 cf Writing . . . . . 3114<sup>a</sup> (Richardson)  
 Book of Abraham  
 cf Apocalyptic Literature . . . . . 161<sup>b</sup> (J. E. H. Thomson)  
 Book of Covenant  
 cf Law in OT . . . . . 1852<sup>a</sup> (Rule)  
 cf Moses . . . . . 2090<sup>a</sup> (Kyle)  
 Book of the Dead  
 cf Libraries . . . . . 1882<sup>b</sup> (Richardson)  
 Book of Enoch . . . . . 164<sup>b</sup> (J. E. H. Thomson)  
 Book of Jubilees  
 cf Apocalyptic Literature . . . . . 166<sup>b</sup> (J. E. H. Thomson)  
 cf Apocrypha . . . . . 178<sup>b</sup> (T. W. Davies)  
 Book of Lamentations  
 cf Languages of OT . . . . . 1836<sup>a</sup> (Weir)  
 Book of Life . . . . . 503<sup>a</sup> (Kaiser); 490<sup>b</sup>  
 cf Apocalyptic Literature . . . . . 161<sup>b</sup> (J. E. H. Thomson)  
 Book of Noah  
 cf Apocalyptic Literature . . . . . 161<sup>b</sup> (J. E. H. Thomson)  
 Book of Ob  
 cf Judah, Kingdom of . . . . . 1762<sup>b</sup> (Weir)  
 Book of Remembrance . . . . . 503<sup>b</sup>  
 Books of Adam . . . . . 54<sup>a</sup> (M. O. Evans); 177<sup>a</sup>  
 (J. E. H. Thomson); 178<sup>b</sup>  
 (T. W. Davies)  
 cf Apocalyptic Literature . . . . . 161<sup>b</sup> (J. E. H. Thomson)  
 Boot . . . . . 503<sup>b</sup>  
 Booth . . . . . 503<sup>b</sup> (T. Lewis)  
 Booths, Feast of  
 cf Feasts and Fasts . . . . . 1103<sup>a</sup> (E. D. Isaacs)  
 Booty . . . . . 503<sup>b</sup> (W. L. Walker)  
 cf Prey . . . . . 2439<sup>a</sup> (W. L. Walker)  
 Booz . . . . . 503<sup>b</sup>  
 Bor-ashan . . . . . 503<sup>b</sup>  
 Border, Borders . . . . . 503<sup>b</sup> (Hirsch)  
 cf Hem . . . . . 1374<sup>a</sup> (Eager)  
 cf Quarter . . . . . 2513<sup>a</sup>  
 Borderer . . . . . 504<sup>a</sup>  
 Bore . . . . . 504<sup>a</sup> (T. Lewis)  
 Borez  
 cf Michmash . . . . . 2048<sup>a</sup> (Ewing)  
 Borith . . . . . 504<sup>a</sup>  
 Born . . . . . 418<sup>a</sup>  
 Born Again  
 cf Regeneration . . . . . 2546<sup>b</sup> (Nuelsen)  
 Borne . . . . . 418<sup>a</sup>  
 Borrowing . . . . . 504<sup>a</sup> (Eager)  
 Boscath (Bozkath) . . . . . 512<sup>b</sup>  
 Bosom . . . . . 504<sup>b</sup> (Hirsch)  
 Bosom, Abraham's . . . . . 22<sup>b</sup> (Orr)  
 Bosor . . . . . 504<sup>b</sup>  
 Bosora . . . . . 504<sup>b</sup> (Ewing)  
 Boss . . . . . 505<sup>a</sup>  
 Botany . . . . . 505<sup>a</sup> (Masterman)  
 Fertility and climate in  
 modern and ancient  
 Palestine . . . . . 505<sup>b</sup>  
 Decrease in rainfall . . . . . 506<sup>a</sup>  
 Destruction of forests . . . . . 506<sup>a</sup>  
 Vegetation of Biblical times . . . . . 506<sup>b</sup>  
 cf Flowers . . . . . 1120<sup>b</sup> (Masterman)  
 cf Forest . . . . . 1132<sup>a</sup> (Masterman)  
 cf Judah, Territory of . . . . . 1764<sup>a</sup> (Masterman)  
 cf Myrrh . . . . . 2102<sup>b</sup> (Masterman)  
 Palestinian flora . . . . . 505<sup>a</sup>  
 General characteristics . . . . . 505<sup>a</sup>  
 Modern plants . . . . . 505<sup>a</sup>  
 Plant zone in Holy  
 Land . . . . . 507<sup>a</sup>  
 Jordan valley . . . . . 508<sup>b</sup>  
 Lebanon and Anti-Lebanon flora . . . . . 509<sup>b</sup>  
 Plains and mountains . . . . . 507<sup>a</sup>  
 Steppe or desert zones . . . . . 509<sup>a</sup>  
 cf Thorns, Thistles . . . . . 2974<sup>a</sup> (Masterman)  
 Botch  
 cf Boil . . . . . 494<sup>a</sup> (Macalister)  
 Botrys . . . . . 509<sup>b</sup>

- Bottle . . . . . 509<sup>b</sup> (Eager)  
   of Pitcher . . . . . 2401<sup>b</sup>  
   of Tears . . . . . 2923<sup>b</sup> (Macalister)  
   of Vessel . . . . . 3049<sup>a</sup> (Easton)  
 Bottom . . . . . 510<sup>b</sup> (M. O. Evans)  
 Bottomless . . . . . 511<sup>a</sup>  
 Bough  
   of Branch . . . . . 513<sup>b</sup> (Masterman)  
 Bought (of a sling) . . . . . 511<sup>a</sup>  
 Bought . . . . . 511<sup>a</sup>  
   of Buying . . . . . 533<sup>a</sup> (Eager)  
 Bound  
   of Bind . . . . . 474<sup>b</sup> (Kapp)  
 Bounds . . . . . 511<sup>a</sup>  
 Bountifulness, Bounty . . . . . 511<sup>a</sup> (Kaiser)  
 Bow  
   of Archery . . . . . 233<sup>b</sup> (Eager)  
 Bow and Arrows . . . . . 252<sup>a</sup> (Nicol)  
 Bow, Bowing  
   of Adoration . . . . . 60<sup>a</sup> (Edwards); 330<sup>b</sup> (W. Davies)  
 Bow in the Cloud . . . . . 511<sup>a</sup>  
   of Astronomy . . . . . 300<sup>b</sup> (Maunder)  
 Bowels . . . . . 511<sup>a</sup> (Luering)  
 Bowing . . . . . 511<sup>b</sup>  
 Bowl . . . . . 511<sup>b</sup> (Eager)  
   of Pommel . . . . . 2418<sup>a</sup>  
 Bowman . . . . . 512<sup>a</sup> (Eager)  
   of Archery . . . . . 233<sup>b</sup> (Eager)  
 Bowshot . . . . . 512<sup>a</sup>  
 Box . . . . . 512<sup>a</sup>  
 Boxing  
   of Games . . . . . 1168<sup>b</sup> (Smith)  
 Box-tree . . . . . 512<sup>a</sup> (Masterman)  
 Boy . . . . . 512<sup>b</sup> (Kapp)  
   of Child . . . . . 606<sup>b</sup> (Stearns)  
   of Family . . . . . 1094<sup>b</sup> (Caverno)  
   of Son . . . . . 2826<sup>a</sup> (Betteridge)  
 Bozcath (Bozkath) . . . . . 512<sup>b</sup>  
 Bozez . . . . . 512<sup>b</sup> (Ewing)  
   of Seneh . . . . . 2720<sup>a</sup> (Ewing)  
 Bozkath . . . . . 512<sup>b</sup>  
 Bozrah . . . . . 512<sup>b</sup> (Ewing)  
   of Sela . . . . . 2713<sup>b</sup> (Ewing)  
 Bracelet . . . . . 512<sup>b</sup> (Eager)  
 Brag . . . . . 513<sup>a</sup>  
 Braided, Braiding . . . . . 513<sup>b</sup>  
   of Embroidery . . . . . 940<sup>a</sup> (Patch)  
   of Plaiting . . . . . 2407<sup>b</sup>  
 Bramble  
   of Thorns, Thistles . . . . . 2974<sup>a</sup> (Masterman)  
 Bran . . . . . 513<sup>b</sup>  
 Branch, Bough . . . . . 513<sup>b</sup> (Masterman)  
   of Nose . . . . . 2155<sup>b</sup> (Luering)  
   of Zoroastrianism . . . . . 3157<sup>a</sup> (Easton)  
 Brand . . . . . 514<sup>a</sup>  
   of Firebrand . . . . . 1112<sup>b</sup> (W. L. Walker)  
 Branding  
   of Punishments . . . . . 2504<sup>b</sup> (Hirsch)  
 Brasen  
   of Brass . . . . . 514<sup>a</sup> (Patch); 736<sup>a</sup> (Patch)
- Brass, Brazen . . . . . 514<sup>a</sup> (Patch); 736<sup>a</sup> (Patch)  
   of Steel . . . . . 2850<sup>b</sup>  
 Bravery . . . . . 514<sup>a</sup>  
 Brawler . . . . . 514<sup>a</sup> (Kaiser)  
 Bray . . . . . 514<sup>b</sup> (M. O. Evans)  
   of Mortar . . . . . 2083<sup>a</sup> (Orr)  
 Brazen . . . . . 514<sup>a</sup> (Patch); 736<sup>a</sup> (Patch)  
 Brazen Altar  
   of Temple . . . . . 2933<sup>a</sup> (Caldecott; Orr)  
 Brazen Sea  
   of Knop . . . . . 1815<sup>b</sup>  
   of Temple . . . . . 2930<sup>a</sup> (Caldecott; Orr)  
 Brazen Serpent . . . . . 2736<sup>a</sup> (Day)  
   of Images . . . . . 1455<sup>a</sup> (Cobern)  
   of Moses . . . . . 2088<sup>a</sup> (Kyle)  
 Breach . . . . . 514<sup>b</sup> (Hirsch)  
 Breach of Covenant  
   of Crimes . . . . . 746<sup>a</sup> (Hirsch)  
 Breach of Ritual  
   of Crimes . . . . . 746<sup>a</sup> (Hirsch)  
 Breach of Trust . . . . . 3025<sup>a</sup>  
 Bread . . . . . 514<sup>b</sup> (Eager)  
   Bread-making . . . . . 515<sup>a</sup>  
     Baking . . . . . 515<sup>b</sup>  
     Forms of loaves . . . . . 516<sup>a</sup>  
     Grinding . . . . . 515<sup>a</sup>  
     Kneading . . . . . 515<sup>b</sup>  
     Ovens . . . . . 515<sup>b</sup>  
   Dietary preëminence  
     of . . . . . 515<sup>a</sup>  
   of Food . . . . . 1121<sup>b</sup> (Eager)  
   of Hospitality . . . . . 1432<sup>a</sup> (Easton)  
   of Leaven . . . . . 1862<sup>a</sup> (Eager)  
   Materials . . . . . 515<sup>a</sup>  
     Barley . . . . . 515<sup>a</sup>  
     Kinds of flour . . . . . 515<sup>a</sup>  
     Wheat . . . . . 515<sup>a</sup>  
   of Meals . . . . . 2013<sup>b</sup> (Eager)  
   Sanctity of bread . . . . . 516<sup>b</sup>  
   Symbolism of bread . . . . . 517<sup>a</sup>  
 Breadth . . . . . 517<sup>a</sup>  
 Break . . . . . 517<sup>a</sup> (Hirsch)  
 Break Asunder . . . . . 316<sup>a</sup> (S. F. Hunter)  
 Break of Day . . . . . 517<sup>b</sup>  
   of Dawn . . . . . 797<sup>b</sup> (Porter)  
 Breast . . . . . 517<sup>b</sup> (Hirsch)  
   of Sacrifice in OT . . . . . 2638<sup>a</sup> (Reeve)  
 Breastplate . . . . . 253<sup>b</sup>  
   of Armor . . . . . 251<sup>a</sup> (Nicol)  
   of Priests and Levites . . . . . 2452<sup>a</sup> (Wiener)  
 Breastplate of the High  
   Priest . . . . . 517<sup>b</sup> (T. Lewis)  
 Breath, Breathe, Breath-  
   ing . . . . . 518<sup>a</sup> (Van Pelt)  
   of Spirit . . . . . 2841<sup>b</sup> (Marais)  
 Breeches . . . . . 518<sup>a</sup> (Wolf)  
 Breed . . . . . 518<sup>b</sup> (Hirsch)  
 Brethren  
   of Brother . . . . . 525<sup>a</sup> (Pratt)  
 Brethren of the Lord . . . . . 518<sup>b</sup> (Jacobs)  
   of James, Brother of  
   the Lord . . . . . 1561<sup>a</sup> (Kerr)

- Brethren of the Lord—*continued*  
 of James, Son of  
   Alphaeus . . . . . 1561<sup>a</sup> (Kerr)  
 of James, Son of Zebedee . . . . . 1560<sup>a</sup> (Kerr)  
 of Joses . . . . . 1743<sup>a</sup>  
 of Jude . . . . . 1767<sup>b</sup>  
 of Simon (brother of Jesus) . . . . . 2795<sup>a</sup> (S. F. Hunter)
- Bribery . . . . . 520<sup>b</sup> (Kaiser)  
 of Crimes . . . . . 745<sup>b</sup> (Hirsch)  
 of Justice . . . . . 1781<sup>b</sup> (Rall)  
 of Punishments . . . . . 2504<sup>b</sup> (Hirsch)
- Brick . . . . . 520<sup>b</sup> (Patch)  
 of Pottery . . . . . 2423<sup>b</sup> (Patch)
- Brick-kiln . . . . . 522<sup>a</sup>
- Bride  
 of Marriage . . . . . 1996<sup>b</sup> (Eager)
- Bride-chamber . . . . . 522<sup>a</sup>  
 of Chamber . . . . . 591<sup>b</sup> (Berry)  
 of Marriage . . . . . 1996<sup>b</sup> (Eager)
- Bride-chamber, Sons of the . . . . . 522<sup>a</sup>
- Bridegroom, Bridegroom, Friend of  
 of Marriage . . . . . 1996<sup>b</sup> (Eager)
- Bridge . . . . . 522<sup>a</sup> (Hirsch)
- Bridle  
 of Bit and Bridle . . . . . 482<sup>b</sup> (W. L. Walker)
- Brier  
 of Thorns, Thistles . . . . . 2974<sup>a</sup> (Masterman)
- Brigandine  
 of Armor, Arms . . . . . 251<sup>a</sup> (Nicol)  
 of Coat of Mail . . . . . 253<sup>b</sup> (Nicol)
- Brightness . . . . . 522<sup>a</sup>
- Brim . . . . . 522<sup>a</sup>
- Brimstone . . . . . 522<sup>b</sup> (Patch)
- Bring . . . . . 522<sup>b</sup> (Hirsch)
- Brink . . . . . 523<sup>a</sup>
- Broad . . . . . 523<sup>a</sup> (Kaiser)  
 of City . . . . . 662<sup>a</sup> (A. C. Dickie)  
 of Gate . . . . . 1175<sup>b</sup> (Easton)
- Broad Place  
 of City . . . . . 662<sup>a</sup> (A. C. Dickie)
- Broidered . . . . . 523<sup>a</sup>  
 of Braided . . . . . 513<sup>b</sup>  
 of Embroidery . . . . . 940<sup>a</sup> (Patch)
- Broken . . . . . 523<sup>a</sup> (Hirsch)  
 of Break . . . . . 517<sup>a</sup> (Hirsch)
- Brokenfooted . . . . . 523<sup>b</sup>
- Brokenhanded . . . . . 523<sup>b</sup>
- Brokenhearted . . . . . 523<sup>b</sup>
- Brooch . . . . . 523<sup>b</sup>  
 of Bracelet . . . . . 512<sup>b</sup> (Eager)  
 of Ring . . . . . 2594<sup>a</sup> (Cranell)
- Brook . . . . . 523<sup>b</sup> (Day)  
 of River . . . . . 2595<sup>a</sup> (Day)  
 of Stream . . . . . 2866<sup>b</sup> (Day)  
 of Vale . . . . . 3045<sup>a</sup> (Day)  
 of Watercourse . . . . . 3074<sup>b</sup> (Day)  
 of Willows, The Brook of . . . . . 3085<sup>b</sup>
- Brook of Egypt, The . . . . . 523<sup>b</sup> (Kyle)  
 of Shihor . . . . . 2768<sup>a</sup> (Kyle)
- Broom . . . . . 525<sup>a</sup> (Estes)  
 of Juniper . . . . . 1781<sup>a</sup> (Masterman)
- Broth . . . . . 525<sup>a</sup> (Eager)  
 of Food . . . . . 1121<sup>b</sup> (Eager)
- Brother . . . . . 525<sup>a</sup> (Pratt)  
 of Relationships, Family . . . . . 2554<sup>a</sup> (N. and E. D. Isaacs)
- Brotherhood . . . . . 525<sup>b</sup>
- Brother-in-Law  
 of Relationships, Family . . . . . 2554<sup>a</sup> (N. and E. D. Isaacs)
- Brotherly . . . . . 525<sup>b</sup> (Pratt)
- Brotherly Kindness,  
 Love . . . . . 525<sup>b</sup> (Rees)  
 Between Christians . . . . . 525<sup>b</sup>  
 Moral idea . . . . . 525<sup>b</sup>  
 Stoic teaching . . . . . 525<sup>a</sup>
- Brother's Wife . . . . . 526<sup>a</sup> (Hirsch)
- Brow . . . . . 526<sup>b</sup>
- Brown  
 of Colors . . . . . 674<sup>b</sup> (Patch)
- Bruise, Bruised . . . . . 526<sup>b</sup> (Kinsella)
- Bruit . . . . . 526<sup>b</sup>
- Brute, Brutish . . . . . 526<sup>b</sup> (Kapp)
- Bubastis  
 of Pi-beseth . . . . . 2394<sup>b</sup> (Kyle)
- Bucket . . . . . 526<sup>b</sup>
- Buckle . . . . . 526<sup>b</sup>
- Buckler . . . . . 526<sup>b</sup>  
 of Armor, Arms . . . . . 251<sup>a</sup> (Nicol)
- Bud  
 of Flowers . . . . . 1120<sup>b</sup> (Masterman)
- Buffalo  
 of Cattle . . . . . 583<sup>b</sup> (Day)
- Buffet . . . . . 527<sup>a</sup> (Kaiser)
- Bugean . . . . . 527<sup>a</sup>
- Build, Building . . . . . 527<sup>a</sup> (A. C. Dickie)  
 of Architecture . . . . . 234<sup>a</sup> (A. C. Dickie)  
 Early building conditions . . . . . 527<sup>a</sup>  
 of Fortification . . . . . 1136<sup>b</sup> (Nicol)  
 Foundations . . . . . 527<sup>a</sup>  
 of House . . . . . 1434<sup>b</sup> (A. C. Dickie)  
 Masonry . . . . . 527<sup>a</sup>; 2007<sup>a</sup>  
 Modern methods . . . . . 527<sup>b</sup>
- Builder . . . . . 527<sup>b</sup> (W. L. Walker)
- Bukki . . . . . 528<sup>a</sup>
- Bukkiah . . . . . 528<sup>a</sup>  
 of Bakbukiah . . . . . 378<sup>a</sup>
- Bul . . . . . 528<sup>a</sup>  
 of Calendar . . . . . 541<sup>b</sup> (Porter)
- Bull, Bullock  
 of Cattle . . . . . 583<sup>b</sup> (Day)
- Bull, Wild  
 of Antelope . . . . . 143<sup>b</sup> (Day)  
 of Cattle . . . . . 583<sup>b</sup> (Day)
- Bulls, Jeroboam's  
 of Calf, Golden . . . . . 542<sup>b</sup> (Cobern)
- Bulrush  
 of Reed . . . . . 2544<sup>a</sup> (Masterman)

- Bulrushes, Ark of . . . . . 242<sup>a</sup> (Kyle)  
 Bulwark . . . . . 528<sup>a</sup>  
   of Fortification . . . . . 1136<sup>b</sup> (Nicol)  
 Bunah . . . . . 528<sup>a</sup>  
 Bunch . . . . . 528<sup>a</sup>  
 Bundle . . . . . 528<sup>a</sup> (Van Pelt)  
 Bunni . . . . . 528<sup>b</sup> (Wolf)  
 Burden . . . . . 528<sup>b</sup> (Trever)  
   of Oracle . . . . . 2198<sup>b</sup> (Easton)  
 Burglary  
   of Crimes . . . . . 746<sup>a</sup> (Hirsch)  
 Burial . . . . . 529<sup>a</sup> (Eager)  
   Burial procession . . . . . 530<sup>a</sup>  
   Coffins unknown . . . . . 530<sup>a</sup>  
   Dirge songs . . . . . 531<sup>b</sup>  
   Professional mourn-  
   ers . . . . . 530<sup>a</sup>  
   Custom of immediate  
   burial . . . . . 529<sup>a</sup>  
   Burial of Jesus . . . . . 529<sup>a</sup>  
   Duties of next of  
   kin . . . . . 529<sup>b</sup>  
   Persons . . . . . 529<sup>a</sup>  
   Time . . . . . 529<sup>b</sup>  
   Failure of burial a  
   calamity . . . . . 531<sup>b</sup>  
 Graves . . . . . 530<sup>b</sup>  
   Dug in the earth . . . . . 530<sup>b</sup>  
   Family tombs . . . . . 530<sup>b</sup>  
   Mourning at grave . . . . . 531<sup>a</sup>  
   Sealed stones . . . . . 531<sup>a</sup>  
   Marking burial places . . . . . 531<sup>b</sup>  
   Preparations . . . . . 529<sup>b</sup>  
   Ceremony . . . . . 529<sup>b</sup>  
   Jewish and other  
   customs . . . . . 530<sup>a</sup>  
   of Sepulchre . . . . . 2732<sup>a</sup>  
   of Shroud . . . . . 2781<sup>a</sup>  
   of Spice . . . . . 2840<sup>a</sup> (Masterman)  
 Burier . . . . . 532<sup>a</sup>  
 Burn, Burning . . . . . 532<sup>a</sup>  
   of Punishments . . . . . 2504<sup>b</sup> (Hirsch)  
 Burnt Offering  
   of Sacrifice . . . . . 2643<sup>a</sup> (Reeve)  
 Burnt Sacrifice  
   of Sacrifice . . . . . 2643<sup>a</sup> (Reeve)  
 Burst Asunder . . . . . 316<sup>b</sup> (S. F. Hunter)  
 Bush . . . . . 532<sup>a</sup> (Masterman)  
 Bush, Burning . . . . . 532<sup>b</sup> (Kyle)  
   of Moses . . . . . 2085<sup>a</sup> (Kyle)  
   of Plagues of Egypt . . . . . 2403<sup>a</sup> (Kyle)  
 Bushel . . . . . 532<sup>b</sup>  
 Bushy . . . . . 533<sup>a</sup>  
 Business . . . . . 533<sup>a</sup> (Kinsella)  
 Busybody . . . . . 533<sup>a</sup> (Dosker)  
 Butler . . . . . 533<sup>a</sup> (Pollard)  
 Butter  
   of Food . . . . . 1121<sup>b</sup> (Eager)  
 Buying . . . . . 533<sup>a</sup> (Eager)  
   In the earliest periods  
   and among nomads . . . . . 533<sup>b</sup>  
   Open air markets . . . . . 535<sup>a</sup>  
 Buying—*continued*  
   Oriental buying . . . . . 534<sup>a</sup>  
   Shops and bazaars . . . . . 534<sup>a</sup>  
 Buz, Buzi, Buzite . . . . . 535<sup>b</sup> (Wolf)  
 By . . . . . 535<sup>b</sup>  
 By and By . . . . . 535<sup>b</sup>  
 Byblus  
   of Gebal . . . . . 1180<sup>a</sup> (Porter)  
 Bypaths (Byway) . . . . . 535<sup>b</sup>  
 Byssus  
   of Linen . . . . . 1894<sup>a</sup> (E. D. Isaacs)  
 Byway . . . . . 535<sup>b</sup>  
 Byword . . . . . 535<sup>b</sup>  
 Cab (Kab) . . . . . 1788<sup>b</sup>  
 Cabbon . . . . . 536<sup>a</sup>  
   of Machbena . . . . . 1959<sup>b</sup>  
 Cabin . . . . . 536<sup>a</sup>  
 Cabul . . . . . 536<sup>a</sup> (Ewing)  
 Caddis  
   of Gaddis . . . . . 1153<sup>a</sup>  
 Cades  
   of Kedesh . . . . . 1791<sup>a</sup>  
 Cades-barne (Kadesh-  
   barnea) . . . . . 1788<sup>b</sup> (S. F. Hunter)  
 Cadhe . . . . . 536<sup>a</sup>  
   of Alphabet . . . . . 103<sup>b</sup> (Richardson)  
 Caesar . . . . . 536<sup>a</sup>  
 Caesarea . . . . . 536<sup>a</sup> (Ewing)  
   of Ships and Boats . . . . . 2774<sup>a</sup> (Nicol)  
   of Transfiguration,  
   Mount of . . . . . 3006<sup>a</sup> (Ewing)  
 Caesarea Philippi  
   of Jesus Christ . . . . . 1648<sup>b</sup> (Orr)  
   of Jordan . . . . . 1733<sup>a</sup> (Wright)  
 Caesar's Household . . . . . 537<sup>a</sup> (Rutherford)  
 Cage . . . . . 538<sup>a</sup> (Stratton-Porter)  
 Caiaphas . . . . . 538<sup>b</sup> (Kerr)  
   of Jesus Christ, Arrest  
   and Trial of . . . . . 1670<sup>a</sup> (Maclaren)  
   of Priest, High . . . . . 2441<sup>b</sup> (Reeve)  
 Cain . . . . . 538<sup>b</sup> (Farr)  
   of Criticism of Bible . . . . . 748<sup>b</sup> (Orr)  
   of Inspiration . . . . . 1473<sup>a</sup> (Warfield)  
   of Kenites . . . . . 1792<sup>a</sup> (Ewing)  
 Cainan . . . . . 839<sup>b</sup>  
 Cake  
   of Bread . . . . . 514<sup>b</sup> (Eager)  
 Calah . . . . . 539<sup>b</sup> (Pinches)  
   of Babel . . . . . 350<sup>a</sup> (Pinches)  
   of Babel, Tower of . . . . . 355<sup>b</sup> (Pinches)  
   of Babylon in the NT . . . . . 358<sup>a</sup> (Fortune)  
   of Resen . . . . . 2561<sup>a</sup> (Pinches)  
 Calamity . . . . . 540<sup>b</sup> (Pratt)  
 Calamolalus . . . . . 541<sup>a</sup>  
 Calamus  
   of Reed . . . . . 2544<sup>a</sup> (Masterman)  
 Calcol . . . . . 541<sup>a</sup>  
 Caldron . . . . . 541<sup>a</sup> (Berry)  
 Caleb . . . . . 541<sup>a</sup> (Margolis)  
   of Moses . . . . . 2088<sup>a</sup> (Kyle)  
 Caleb-ephraiah . . . . . 541<sup>b</sup>

- Calendar . . . . . 541<sup>b</sup> (Porter)  
   of Abib . . . . . 9<sup>a</sup> (Beecher)  
   of Iyyar . . . . . 1545<sup>b</sup>  
   of Kisleb . . . . . 1813<sup>b</sup>  
   of Month . . . . . 2081<sup>a</sup> (Porter)  
   of Nisan . . . . . 2153<sup>a</sup>  
   of Shebat . . . . . 2753<sup>b</sup>  
   of Sivan . . . . . 2813<sup>b</sup>  
   of Tammuz . . . . . 2908<sup>a</sup> (Porter)  
   of Tebeth . . . . . 2924<sup>a</sup>  
   of Third . . . . . 2973<sup>a</sup>  
   of Time . . . . . 2982<sup>a</sup> (Porter)  
   of Tishri (Tisri) . . . . . 2987<sup>a</sup>  
   of Ziv . . . . . 3153<sup>a</sup>  
 Calf . . . . . 542<sup>a</sup> (Day)  
   of Cattle . . . . . 583<sup>b</sup> (Day)  
   of Gods (golden) . . . . . 1271<sup>a</sup> (Reeve)  
 Calf, Golden . . . . . 542<sup>b</sup> (Cobern)  
   of Astrology . . . . . 295<sup>b</sup> (Maunder)  
   of Idolatry . . . . . 1447<sup>b</sup> (Cobern)  
   of Images . . . . . 1452<sup>a</sup> (Cobern)  
   of Israel, History of . . . . . 1520<sup>b</sup> (Orelli)  
   of Moses . . . . . 2087<sup>b</sup> (Kyle)  
 Calf Image  
   of Images . . . . . 1452<sup>a</sup> (Cobern)  
 Calitas . . . . . 545<sup>b</sup> (Edwards)  
 Calker  
   of Ships and Boats . . . . . 2774<sup>a</sup> (Nicol)  
 Calling . . . . . 545<sup>b</sup> (Trever)  
 Callisthenes . . . . . 545<sup>b</sup>  
 Calneh . . . . . 546<sup>a</sup> (Pinches)  
   of Shinar . . . . . 2772<sup>b</sup> (Pinches)  
 Calneh (Calno) . . . . . 546<sup>b</sup>  
 Calphi  
   of Chalphi . . . . . 591<sup>b</sup>  
 Calvary  
   of Golgotha . . . . . 1275<sup>a</sup> (Masterman)  
 Calves of the Lips . . . . . 546<sup>b</sup> (T. Lewis)  
 Calvin  
   of Lord's Supper . . . . . 1926<sup>b</sup> (Dosker)  
 Cambyses . . . . . 546<sup>b</sup> (R. D. Wilson)  
 Camel . . . . . 547<sup>b</sup> (Day)  
   of Horse . . . . . 1423<sup>a</sup> (Day)  
   of Needle . . . . . 2129<sup>b</sup> (Patch)  
   of Swift Beasts . . . . . 2875<sup>b</sup>  
 Camel's Hair . . . . . 548<sup>a</sup> (Patch)  
   of Weaving . . . . . 3077<sup>a</sup> (Patch)  
 Canon . . . . . 548<sup>b</sup>  
   of Kamon . . . . . 1789<sup>b</sup> (Ewing)  
 Camp  
   of War . . . . . 3069<sup>b</sup> (Nicol)  
 Cana of Galilee . . . . . 548<sup>b</sup> (Ewing)  
 Canaan, Canaanites . . . . . 549<sup>a</sup> (Sayce)  
   of Fortification . . . . . 1136<sup>b</sup> (Nicol)  
   Invasion of, archaeo-  
     logical theory . . . . . 232<sup>a</sup> (Kyle)  
   of Traffic . . . . . 3004<sup>b</sup> (Raffety)  
 Canaanitess  
   of Bathshua . . . . . 416<sup>b</sup>  
   of Shua . . . . . 2781<sup>a</sup>  
 Canals . . . . . 552<sup>a</sup> (Kyle)  
   of Stream . . . . . 2866<sup>b</sup> (Day)  
 Cananaean  
   of Simon . . . . . 2795<sup>a</sup> (S. F. Hunter)  
 Candace . . . . . 552<sup>b</sup>  
 Candle . . . . . 552<sup>b</sup> (Eager)  
   of Tabernacle . . . . . 2887<sup>b</sup> (Caldecott; Orr)  
 Candlestick, The Golden . . . . . 553<sup>a</sup> (Orr)  
   of Almond . . . . . 100<sup>a</sup> (Masterman)  
   of Knop . . . . . 1815<sup>b</sup>  
   of Lamp . . . . . 1825<sup>a</sup> (Porter)  
   of Tabernacle . . . . . 2891<sup>a</sup> (Caldecott; Orr)  
   of Temple . . . . . 2938<sup>b</sup> (Caldecott; Orr)  
 Cane  
   of Reed . . . . . 2544<sup>a</sup> (Masterman)  
 Canker  
   of Gangrene . . . . . 1173<sup>b</sup> (Macalister)  
 Cankered . . . . . 553<sup>b</sup>  
 Canker-worm . . . . . 553<sup>b</sup>  
   of Caterpillar . . . . . 583<sup>a</sup>  
 Canneh . . . . . 553<sup>b</sup> (Fortune)  
 Canon, NT . . . . . 563<sup>a</sup> (Riggs); 467<sup>b</sup> (Orr)  
   of Gospels, Synoptic . . . . . 1281<sup>b</sup> (Iverach)  
   of Matthew, Gospel of . . . . . 2009<sup>b</sup> (Schodde)  
 Canon, OT . . . . . 554<sup>a</sup> (Robinson)  
   of Synagogue, The  
     Great . . . . . 2879<sup>b</sup> (Orr)  
 Canonical Apocryphal  
   Gospels . . . . . 195<sup>b</sup> (Hutchison)  
 Canopy . . . . . 566<sup>a</sup> (Sampey)  
 Canticles  
   of Song of Songs . . . . . 2831<sup>a</sup> (Sampey)  
 Caperberry . . . . . 566<sup>b</sup> (Masterman)  
   of Food . . . . . 1124<sup>a</sup> (Eager)  
 Capernaum . . . . . 566<sup>b</sup> (Ewing)  
   of Galilee, Sea of . . . . . 1165<sup>a</sup> (Ewing)  
   of Palestine . . . . . 2221<sup>b</sup> (Conder)  
   of Palestine, Recent  
     Exploration . . . . . 2229<sup>b</sup> (Cobern)  
 Caph (Kaph) . . . . . 1789<sup>b</sup>  
 Capharsalama . . . . . 567<sup>b</sup>  
 Capphenatha  
   of Chapphenatha . . . . . 594<sup>b</sup>  
 Caphira . . . . . 568<sup>a</sup>; 602<sup>b</sup>  
   of Pira . . . . . 2400<sup>a</sup>  
 Caphthorim . . . . . 568<sup>a</sup>  
 Captor, Capthorim . . . . . 568<sup>a</sup> (Ewing)  
 Cappadocia . . . . . 568<sup>a</sup> (White)  
 Captain . . . . . 568<sup>b</sup> (Nicol)  
   of Army, Roman . . . . . 257<sup>a</sup> (Allen)  
   of Augustan Band . . . . . 258<sup>a</sup> (Allen)  
   of Guard . . . . . 1307<sup>b</sup> (Nicol)  
 Captive . . . . . 569<sup>b</sup> (Farr)  
   of Captivity . . . . . 569<sup>b</sup> (Nicol)  
   of War . . . . . 3069<sup>b</sup> (Nicol)  
 Captivity . . . . . 569<sup>b</sup> (Nicol)  
   Northern Kingdom . . . . . 570<sup>a</sup>  
   of Seventy Years . . . . . 2744<sup>b</sup>  
   Southern Kingdom . . . . . 571<sup>b</sup>  
 Captivity Epistles . . . . . 466<sup>b</sup> (Orr)  
   of Philemon . . . . . 2366<sup>b</sup> (C. S. Lewis)  
 Car  
   of Palanquin . . . . . 2208<sup>a</sup>  
 Carabasion . . . . . 576<sup>a</sup>

- Caravan . . . . . 576<sup>b</sup> (T. Lewis)  
 Caravansary  
   of Inn . . . . . 1470<sup>a</sup> (Christie)  
 Carbuncle  
   of Stones, Precious . . . 2856<sup>a</sup> (Fletcher)  
 Carcas . . . . . 576<sup>b</sup>  
 Carcass (Carcase) . . . . . 576<sup>b</sup> (Stearns)  
 Carchemish . . . . . 576<sup>b</sup> (Pinches)  
   of Pharaoh-necoh . . . . 2360<sup>a</sup> (Nicol)  
 Care . . . . . 577<sup>b</sup> (Trevor)  
 Careah (Kareah) . . . . . 1790<sup>a</sup>  
 Careful, Carefulness  
   of Care . . . . . 577<sup>b</sup> (Trevor)  
 Carefully . . . . . 578<sup>a</sup> (Trevor)  
 Careless, Carelessly . . . . 578<sup>b</sup> (Trevor)  
 Carem . . . . . 578<sup>b</sup>  
 Caria . . . . . 578<sup>b</sup> (Banks)  
 Carites . . . . . 578<sup>b</sup>  
 Carmanians (Carmo-  
   nians) . . . . . 580<sup>a</sup> (Hutchison)  
 Carne (Charne) . . . . . 598<sup>a</sup>  
 Carmel . . . . . 579<sup>a</sup> (Ewing)  
 Carmelite . . . . . 579<sup>b</sup>  
   of Hezro, Hezrai . . . . . 1388<sup>b</sup>  
 Carmelites . . . . . 579<sup>b</sup>  
 Carmi . . . . . 579<sup>b</sup> (Wolf)  
 Carmonians . . . . . 580<sup>a</sup> (Hutchison)  
 Carnaim . . . . . 580<sup>a</sup>  
 Carnal . . . . . 580<sup>a</sup> (Trevor)  
   of Man, Natural . . . . . 1974<sup>a</sup> (Webb)  
 Carnion (Carnaim) . . . . . 580<sup>a</sup>  
 Carousings . . . . . 580<sup>a</sup>  
 Carpenter . . . . . 580<sup>a</sup>  
   of Carving . . . . . 581<sup>b</sup> (Patch)  
   of Crafts . . . . . 734<sup>a</sup> (Patch)  
   of Tools . . . . . 2998<sup>b</sup> (Easton)  
 Carpus . . . . . 580<sup>b</sup> (Dosker)  
 Carriage . . . . . 580<sup>b</sup> (Patch)  
 Carry . . . . . 580<sup>b</sup> (Fortune)  
 Carshena . . . . . 580<sup>b</sup>  
   of Prince . . . . . 2453<sup>a</sup> (Baur)  
 Cart . . . . . 581<sup>a</sup> (Patch)  
 Carving . . . . . 581<sup>b</sup> (Patch)  
   of Crafts . . . . . 734<sup>a</sup> (Patch)  
 Casdim (Chesed) . . . . . 605<sup>a</sup> (Sampsey)  
 Case . . . . . 581<sup>b</sup>  
 Casement  
   of House . . . . . 1434<sup>b</sup> (A. C. Dickie)  
 Casiphia . . . . . 581<sup>b</sup>  
 Casluhim . . . . . 581<sup>b</sup>  
   of Philistines . . . . . 2376<sup>b</sup> (Conder)  
 Casphon (Casphor) . . . . . 581<sup>b</sup>  
 Casphor . . . . . 581<sup>b</sup>  
   of Ashstoreth . . . . . 270<sup>b</sup> (Sayce)  
 Caspin (Caspis)  
   of Casphor . . . . . 581<sup>b</sup>  
 Cassia . . . . . 582<sup>a</sup> (Masterman)  
 Cast . . . . . 582<sup>a</sup> (Jacobs)  
 Castanets . . . . . 582<sup>a</sup> (Fortune)  
 Castaway . . . . . 582<sup>a</sup>  
 Castle  
   of Fortification . . . . . 1136<sup>b</sup> (Nicol)  
 Castor and Pollux  
   of Astronomy . . . . . 300<sup>b</sup> (Maunder)  
   of Dioscuri . . . . . 851<sup>a</sup> (Maunder)  
 Cat . . . . . 582<sup>b</sup> (Hutchison)  
   of Zoology . . . . . 3155<sup>a</sup> (Day)  
 Catechist, Catechumen . . . . 582<sup>b</sup> (Gerberding)  
   of Education . . . . . 900<sup>b</sup> (Meyer)  
   of Gospels, Synoptic . . . . 1283<sup>b</sup> (Iverach)  
   of Mark, Gospel of . . . . . 1991<sup>b</sup> (Farmer)  
   of Spiritual Gifts . . . . . 2843<sup>a</sup> (Lambert)  
   of Teacher . . . . . 2921<sup>a</sup> (DeMent)  
 Caterpillar . . . . . 583<sup>a</sup>  
   of Canker-worm . . . . . 553<sup>b</sup>  
   of Locust . . . . . 1907<sup>b</sup> (Day)  
 Catholic Epistles . . . . . 583<sup>a</sup> (Pratt)  
   of Bible, The . . . . . 467<sup>a</sup> (Orr)  
 Cathua . . . . . 583<sup>b</sup>  
 Cattle . . . . . 583<sup>b</sup> (Day)  
   of Antelope . . . . . 143<sup>b</sup> (Day)  
   of Beast . . . . . 418<sup>b</sup> (Day)  
   of Calf . . . . . 542<sup>a</sup> (Day)  
   of Sheep . . . . . 2756<sup>b</sup> (Day)  
   of Wild-ox . . . . . 3084<sup>b</sup> (Day)  
 Cauda . . . . . 584<sup>b</sup> (Calder)  
 Caul . . . . . 584<sup>b</sup> (Luering)  
   of Liver . . . . . 1905<sup>b</sup> (Luering)  
 Cause . . . . . 585<sup>a</sup> (Stearns)  
 Causeway . . . . . 585<sup>a</sup> (Stearns)  
 Cave . . . . . 585<sup>a</sup> (Day)  
   of Adullam . . . . . 62<sup>b</sup> (Beecher)  
   of Den . . . . . 829<sup>b</sup> (Day)  
   of Machpelah . . . . . 1959<sup>b</sup> (Masterman)  
   of Makkedah . . . . . 1969<sup>a</sup> (Ewing)  
 Cease . . . . . 586<sup>a</sup> (Pratt)  
 Cedar . . . . . 586<sup>a</sup> (Masterman); 509<sup>b</sup>  
   (Masterman)  
   of Heifer, Red . . . . . 1367<sup>b</sup> (Easton)  
 Cedars of Lebanon . . . . . 586<sup>a</sup>  
   of Lebanon . . . . . 1863<sup>a</sup> (Wright)  
 Cedron (Kidron) . . . . . 1798<sup>a</sup>  
 Ceilan (Kilan) . . . . . 1798<sup>b</sup>  
 Ceiled, Ceiling . . . . . 587<sup>a</sup> (Berry)  
 Celebrate . . . . . 587<sup>a</sup> (Pratt)  
 Celestial . . . . . 587<sup>b</sup> (Pratt)  
 Cellar . . . . . 587<sup>b</sup> (Berry)  
 Celo-Syria  
   of Coele-Syria . . . . . 672<sup>b</sup> (Ewing)  
 Cencreae . . . . . 587<sup>b</sup>  
 Cendebaeus . . . . . 587<sup>b</sup>  
 Censer . . . . . 587<sup>b</sup> (T. Lewis)  
   of Firepan . . . . . 1113<sup>a</sup> (Hovey)  
   of Incense . . . . . 1466<sup>b</sup> (Orr)  
 Census  
   of Chronology of NT . . . . . 645<sup>a</sup> (Armstrong)  
   of David . . . . . 790<sup>b</sup> (Weir)  
 Centurion . . . . . 588<sup>a</sup> (Nicol)  
   of Augustan Band . . . . . 258<sup>a</sup> (Allen)  
 Cephas  
   of Peter . . . . . 2348<sup>b</sup> (Gray)  
 Ceras (Keras) . . . . . 1793<sup>a</sup>  
 Cereals  
   of Food . . . . . 1122<sup>a</sup> (Eager)  
   of Meals . . . . . 2013<sup>b</sup> (Eager)



- Cerinthus  
   of John, 1 Ep. of . . . . . 1714<sup>a</sup> (Law)  
 Certain, Certainly, Cer-  
   tainty . . . . . 588<sup>a</sup> (Stearns)  
 Certify . . . . . 588<sup>b</sup>  
 Cetab (Ketab) . . . . . 1793<sup>b</sup>  
 Chabiri  
   of Tell el-Amarna . . . . . 2927<sup>b</sup> (Kyle)  
 Chabris . . . . . 588<sup>b</sup>  
 Chadias . . . . . 588<sup>b</sup>  
 Chaereas . . . . . 588<sup>b</sup>  
 Chafe . . . . . 588<sup>b</sup>  
 Chaff . . . . . 588<sup>b</sup> (Patch)  
   of Agriculture . . . . . 75<sup>b</sup> (Patch)  
   of Rolling Thing . . . . . 2597<sup>b</sup>  
   of Straw . . . . . 2866<sup>b</sup> (Patch)  
 Chain . . . . . 589<sup>a</sup> (Fortune)  
   of Fetter . . . . . 1107<sup>b</sup>  
   of Punishments . . . . . 2504<sup>b</sup> (Hirsch)  
 Chair  
   of Seat . . . . . 2710<sup>b</sup> (Cotton)  
 Chalcedony  
   of Stones, Precious . . . . . 2856<sup>a</sup> (Fletcher)  
 Chalcol (Calcol) . . . . . 541<sup>a</sup>  
 Chaldea . . . . . 589<sup>b</sup> (Pinches)  
   of Babylonia . . . . . 358<sup>b</sup> (Clay)  
   of Shinar . . . . . 2771<sup>b</sup> (Pinches)  
 Chalkol . . . . . 541<sup>a</sup>  
 Chalkstone . . . . . 591<sup>a</sup> (Day)  
   of Clay . . . . . 667<sup>a</sup> (Day)  
   of Lime . . . . . 1893<sup>b</sup> (Day)  
   of Slime . . . . . 2817<sup>b</sup> (Day)  
 Challenge . . . . . 591<sup>a</sup>  
 Chalphi . . . . . 591<sup>b</sup>  
 Chamber, Roof Chamber . 591<sup>b</sup> (Berry)  
 Chambering . . . . . 591<sup>b</sup>  
 Chamberlain . . . . . 591<sup>b</sup> (Pollard)  
 Chambers in the Heavens  
   of Astronomy . . . . . 300<sup>b</sup> (Maunder)  
   of Dial of Abaz . . . . . 841<sup>a</sup> (Maunder)  
 Chambers of Imagery . . . . . 592<sup>a</sup>  
   of Images . . . . . 1452<sup>a</sup> (Cobern)  
 Chambers in South  
   of Astronomy . . . . . 300<sup>b</sup> (Maunder)  
   of South, Chambers of . 2838<sup>b</sup>  
 Chameleon . . . . . 592<sup>a</sup> (Day)  
   of Ferret . . . . . 1106<sup>b</sup> (Day)  
   of Land-crocodile . . . . . 1826<sup>b</sup> (Day)  
   of Lizard . . . . . 1906<sup>a</sup> (Day)  
   of Mole . . . . . 2074<sup>a</sup> (Day)  
   of Pelican . . . . . 2297<sup>a</sup> (Stratton-Porter)  
   of Swan . . . . . 2874<sup>b</sup> (Stratton-Porter)  
 Chamois . . . . . 592<sup>b</sup> (Day)  
   of Goat . . . . . 1249<sup>a</sup> (Day)  
 Campaign . . . . . 592<sup>b</sup> (Day)  
   of Arabah . . . . . 211<sup>b</sup> (Wright)  
   of Natural Features . . . . . 2122<sup>a</sup> (Day)  
   of Vale . . . . . 3045<sup>a</sup> (Day)  
 Champion . . . . . 593<sup>a</sup>  
 Chanaan  
   of Canaan . . . . . 549<sup>a</sup> (Sayce)
- Chance . . . . . 593<sup>a</sup> (Trevor)  
   of Gad . . . . . 1152<sup>a</sup> (Stearns)  
   of Happen . . . . . 1336<sup>b</sup> (W. L. Walker)  
   of Meni . . . . . 2033<sup>a</sup>  
 Chancellor . . . . . 593<sup>b</sup> (Stearns)  
 Change . . . . . 593<sup>b</sup> (Pratt)  
 Change of Raiment  
   of Dress . . . . . 875<sup>b</sup> (Eager)  
 Changer . . . . . 594<sup>a</sup>  
   of Bank, Banking . . . . . 383<sup>a</sup> (Eager)  
   of Money-changers . . . . . 2080<sup>b</sup> (Pollard)  
 Channel . . . . . 594<sup>a</sup> (Day)  
   of Brook . . . . . 523<sup>b</sup> (Day)  
   of River . . . . . 2595<sup>a</sup> (Day)  
   of Stream . . . . . 2866<sup>b</sup> (Day)  
 Chant . . . . . 594<sup>a</sup>  
 Chanuneus . . . . . 594<sup>b</sup>  
 Chapel . . . . . 594<sup>b</sup>  
 Chaphenatha . . . . . 594<sup>b</sup>  
 Chapter  
   of Architecture . . . . . 234<sup>a</sup> (A. C. Dickie)  
 Chapman . . . . . 594<sup>b</sup>  
   of Trade . . . . . 3002<sup>a</sup> (Easton)  
 Chapt . . . . . 594<sup>b</sup>  
 Chapters  
   of Text of the OT . . . . . 2963<sup>b</sup> (Weir)  
 Charaathalan . . . . . 594<sup>b</sup>  
 Characa (Charax) . . . . . 594<sup>b</sup>  
 Charashim  
   of Ge-barashim . . . . . 1182<sup>a</sup>  
 Charax . . . . . 594<sup>b</sup>  
 Charchemish (Carche-  
   mish) . . . . . 576<sup>b</sup> (Pinches) .  
 Charchus  
   of Barchus . . . . . 403<sup>b</sup>  
 Charea . . . . . 594<sup>b</sup>  
   of Harsha . . . . . 1341<sup>a</sup>  
 Charge, Chargeable . . . . . 594<sup>b</sup> (M. O. Evans)  
 Charger . . . . . 595<sup>a</sup> (Estes)  
 Charges . . . . . 595<sup>a</sup>  
   of Overcharge . . . . . 2205<sup>a</sup>  
 Chariot . . . . . 595<sup>a</sup> (Nicol)  
 Chariots of the Sun . . . . . 596<sup>b</sup> (Margolis)  
   of Images . . . . . 1452<sup>a</sup> (Cobern)  
 Charitably . . . . . 596<sup>b</sup>  
 Charity . . . . . 597<sup>a</sup> (Rees)  
 Charm . . . . . 597<sup>b</sup> (T. W. Davies)  
   of Magic, Magician . . . . . 1963<sup>a</sup> (T. W. Davies)  
 Charme . . . . . 598<sup>a</sup>  
 Charmis . . . . . 598<sup>a</sup>  
 Charran (Haran) . . . . . 1337<sup>a</sup>  
 Chase  
   of Hunting . . . . . 1440<sup>a</sup> (Smith)  
 Chaseba . . . . . 598<sup>b</sup>  
 Chaste, Chastity  
   of Crimes . . . . . 745<sup>b</sup> (Hirsch)  
   of Marriage . . . . . 1996<sup>b</sup> (Eager)  
 Chastening, Chastise-  
   ment . . . . . 598<sup>b</sup> (Jacobs)  
 Chatter . . . . . 599<sup>a</sup>  
   of Chirp . . . . . 612<sup>a</sup> (W. L. Walker)  
 Chavah . . . . . 599<sup>a</sup>

- Chebar . . . . . 599<sup>a</sup> (Ewing)  
 Check . . . . . 599<sup>a</sup>  
 Checker-work . . . . . 599<sup>a</sup>  
   of Broidered . . . . . 523<sup>a</sup>  
   of Embroidery . . . . . 940<sup>a</sup> (Patch)  
 Chedorlaomer . . . . . 599<sup>a</sup> (Pinches)  
   of Hammurabi . . . . . 1326<sup>a</sup> (Pinches)  
   of Tidal . . . . . 2980<sup>a</sup> (Pinches)  
 Cheek, Cheekbone . . . . . 600<sup>a</sup> (Luering)  
 Cheek Teeth . . . . . 600<sup>b</sup>  
 Cheer, Cheerfulness . . . . . 600<sup>b</sup> (Edwards)  
 Cheese  
   of Food . . . . . 1123<sup>b</sup> (Eager)  
   of Milk . . . . . 2051<sup>b</sup> (N. Isaacs)  
 Chelal . . . . . 600<sup>b</sup>  
 Chelcias  
   of Helkias . . . . . 1371<sup>a</sup>  
   of Hilkiah . . . . . 1392<sup>a</sup> (Wallace)  
 Chellians . . . . . 600<sup>b</sup>  
 Chelluh (Cheluhi) . . . . . 601<sup>a</sup>  
 Chellus . . . . . 600<sup>b</sup>  
 Chelod . . . . . 600<sup>b</sup>  
 Chelub . . . . . 600<sup>b</sup>  
   of Genealogy . . . . . 1183<sup>b</sup> (Crannell)  
 Chelubai . . . . . 601<sup>a</sup>  
   of Caleb . . . . . 541<sup>a</sup> (Margolis)  
 Cheluhi . . . . . 601<sup>a</sup>  
 Chemarim . . . . . 601<sup>a</sup> (Van Pelt)  
   of Priests and Levites 2446<sup>b</sup> (Wiener)  
 Chemosh . . . . . 601<sup>a</sup> (Nicol)  
   of Gods . . . . . 1271<sup>a</sup> (Reeve)  
   of Moab . . . . . 2070<sup>b</sup> (Porter)  
   of Semites, Semitic  
     Religion . . . . . 2717<sup>a</sup> (Mack)  
 Chenaanah . . . . . 602<sup>b</sup>  
 Chenani . . . . . 602<sup>b</sup>  
 Chenaniah . . . . . 602<sup>b</sup>  
 Chephar-ammoni . . . . . 602<sup>b</sup>  
 Chephar-haamoni  
   of Chephar-ammoni . . . . . 602<sup>b</sup>  
 Chephirah . . . . . 602<sup>b</sup>  
 Cheran . . . . . 603<sup>a</sup>  
 Cherethites . . . . . 603<sup>a</sup> (Ewing)  
   of Captor . . . . . 568<sup>a</sup> (Ewing)  
   of Pelethites . . . . . 2297<sup>a</sup>  
   of Stranger and So-  
     journer (OT) . . . . . 2865<sup>a</sup> (Wiener)  
 Cherish . . . . . 603<sup>a</sup>  
 Cherith, The Brook . . . . . 603<sup>a</sup>  
 Cherub (place) . . . . . 603<sup>b</sup>  
 Cherubic Forms in the  
   Constellations  
   of Astronomy . . . . . 300<sup>b</sup> (Maunder)  
 Cherubim . . . . . 603<sup>b</sup> (Margolis)  
   of Astronomy . . . . . 310<sup>b</sup> (Maunder)  
   of Tabernacle . . . . . 2890<sup>b</sup> (Caldecott; Orr)  
   of Temple . . . . . 2933<sup>b</sup> (Caldecott; Orr)  
 Chesalon . . . . . 604<sup>b</sup>  
   of Jearim, Mount . . . . . 1572<sup>b</sup>  
 Chesed . . . . . 605<sup>a</sup> (Sampey)  
 Chesil . . . . . 605<sup>a</sup>  
 Chest . . . . . 605<sup>a</sup> (Eager)  
 Chestnut Tree  
   of Plane Tree . . . . . 2407<sup>b</sup>  
 Chesulloth . . . . . 605<sup>b</sup>  
 Cheth (Heth) . . . . . 1384<sup>b</sup>  
 Chettim (Kittim) . . . . . 1814<sup>b</sup> (Pinches)  
 Chew Cud . . . . . 605<sup>b</sup> (N. Isaacs)  
 Chezib (Achzib) . . . . . 37<sup>b</sup> (Mack)  
 Chicken . . . . . 605<sup>b</sup> (Stratton-Porter)  
 Chide . . . . . 606<sup>a</sup>  
 Chidon, The Threshing-  
   floor of . . . . . 606<sup>a</sup>  
 Chief . . . . . 606<sup>a</sup> (Farr)  
   of Asiarch . . . . . 282<sup>a</sup> (M. O. Evans)  
 Chief Friends, Good Men  
   of Friends, Chief  
     Friends . . . . . 1146<sup>a</sup>  
 Chief Musician  
   of Asaph . . . . . 262<sup>b</sup> (Millar)  
 Chief Seats . . . . . 606<sup>b</sup> (J. M. Wilson)  
   of Synagoguc . . . . . 2878<sup>b</sup> (Levertoff)  
 Child, Children . . . . . 606<sup>b</sup> (Stearns; Fortune)  
   of Firstborn, Firstling . 1113<sup>b</sup> (T. Lewis)  
 Child-bearing . . . . . 607<sup>b</sup> (Jacobs)  
 Childhood, Apocryphal  
   Gospel of the  
   of Apocryphal Gospels 195<sup>a</sup> (Hutchison)  
 Children of the Bride-  
   chamber  
   of Bridechamber, Sons  
     of the . . . . . 522<sup>a</sup>  
 Children of the East . . . . . 610<sup>b</sup> (Fortune); 888<sup>b</sup> (Day)  
   of People . . . . . 2319<sup>a</sup> (Easton)  
 Children of Eden . . . . . 607<sup>b</sup> (Fortune)  
 Children of God . . . . . 608<sup>a</sup> (Rees)  
   of Adoption . . . . . 58<sup>a</sup> (Rees)  
   of Father, God the . . . . . 1100<sup>b</sup> (Orr)  
   of God . . . . . 1261<sup>b</sup> (Rees)  
   of Jesus Christ . . . . . 1624<sup>a</sup> (Orr)  
   of Sons of God (OT) . . . . . 2835<sup>a</sup> (Crichton)  
 Children of Israel . . . . . 610<sup>b</sup> (Fortune)  
 Chileab . . . . . 611<sup>a</sup> (Wolf)  
 Chilion . . . . . 611<sup>a</sup> (W. L. Walker)  
 Chilmad . . . . . 611<sup>a</sup> (Pinches)  
 Chimham . . . . . 611<sup>a</sup> (Wolf)  
 Chimney  
   of House . . . . . 1434<sup>b</sup> (A. C. Dickie)  
 Chinnereth . . . . . 611<sup>a</sup>  
 Chios . . . . . 611<sup>b</sup> (Harry)  
   of Samos . . . . . 2674<sup>b</sup> (Kinsella)  
 Chirp . . . . . 612<sup>a</sup> (W. L. Walker)  
   of Chatter . . . . . 599<sup>a</sup>  
 Chisleu (Kislev) . . . . . 1813<sup>b</sup>  
 Chislon . . . . . 612<sup>a</sup>  
 Chisloth-tabor  
   of Chesulloth . . . . . 605<sup>b</sup>  
 Chitlish . . . . . 612<sup>a</sup>  
 Chittim (Kittim) . . . . . 1814<sup>b</sup> (Pinches)  
 Chium . . . . . 612<sup>a</sup> (Margolis)  
   of Astrology . . . . . 295<sup>b</sup> (Maunder)  
   of Rephan . . . . . 2560<sup>a</sup>  
   of Semites, Semitic  
     Religion . . . . . 2717<sup>a</sup> (Mack)

- Chloe . . . . . 612<sup>a</sup> (Kaiser)  
 Choba, Chobai . . . . . 612<sup>b</sup>  
 Choenix . . . . . 612<sup>b</sup>  
 Choice  
   of Choose . . . . . 612<sup>b</sup> (Rees)  
   of Providence . . . . . 2482<sup>a</sup> (Tillett)  
   of Will . . . . . 3085<sup>a</sup> (W. L. Walker)  
 Choke . . . . . 612<sup>b</sup> (Fortune)  
 Chola . . . . . 612<sup>b</sup>  
 Choler . . . . . 612<sup>b</sup>  
 Choose, Chosen . . . . . 612<sup>b</sup> (Rees)  
   of Foreordain, Fore-  
   ordination . . . . . 1131<sup>a</sup> (Orr)  
 Chop . . . . . 614<sup>a</sup>  
 Chorashan (Cor-ashan) . . . . . 709<sup>b</sup>  
 Chorazin . . . . . 614<sup>a</sup> (Ewing)  
   of Palestine . . . . . 2221<sup>b</sup> (Conder)  
 Chorbe . . . . . 614<sup>a</sup>  
 Chosamaeus . . . . . 614<sup>a</sup>  
 Chosen  
   of Choose . . . . . 612<sup>b</sup> (Rees)  
 Chozeba  
   of Achzib . . . . . 37<sup>b</sup> (Mack)  
 Christ, Exaltation of . . . . . 614<sup>b</sup> (Bevan)  
   Ascension . . . . . 263<sup>b</sup> (Thomas); 615<sup>a</sup>  
   (Bevan)  
   Judgment . . . . . 1777<sup>a</sup> (Jacobs)  
   Parousia . . . . . 2249<sup>a</sup> (Easton)  
   Resurrection . . . . . 2565<sup>b</sup> (Thomas)  
 Christ, Intercession of  
   of Intercession of  
   Christ . . . . . 1487<sup>b</sup> (Bevan)  
 Christ, Jesus  
   of Jesus Christ . . . . . 1624<sup>a</sup> (Orr)  
 Christ as King, Priest,  
   Prophet  
   of Christ, Offices of . . . . . 616<sup>b</sup> (Bevan)  
   of King, Christ as . . . . . 1802<sup>a</sup> (M'Caig)  
   of Priest . . . . . 2441<sup>a</sup> (Moorehead)  
 Christ, Offices of . . . . . 616<sup>b</sup> (Bevan)  
   of King, Christ as . . . . . 1802<sup>a</sup> (M'Caig)  
   of Priest . . . . . 2441<sup>a</sup> (Moorehead)  
   of Priest, High . . . . . 2441<sup>b</sup> (Reeve)  
   of Priesthood . . . . . 2444<sup>a</sup> (Moorehead)  
 Christ, Person of . . . . . 2338<sup>a</sup> (Warfield)  
 Christ, Temptation of . . . . . 2943<sup>a</sup> (Anderson)  
 Christian . . . . . 621<sup>b</sup> (J. Dickie)  
 Christianity  
   In Arabia . . . . . 219<sup>a</sup> (Weir)  
   Historical and doc-  
   trinal . . . . . 624<sup>b</sup> (Orr)  
   In principle and  
   essence . . . . . 623<sup>a</sup> (J. Dickie)  
   of Leviticus . . . . . 1880<sup>a</sup> (Möller)  
   of Nero . . . . . 2138<sup>a</sup> (Angus)  
 Christology  
   of Person of Christ . . . . . 2338<sup>a</sup> (Warfield)  
 Christs  
   of Christs, False . . . . . 628<sup>b</sup> (Orr)  
   of Messiah . . . . . 2039<sup>a</sup> (Crichton)  
 Christs, False . . . . . 628<sup>b</sup> (Orr)
- Chronicles, Books of . . . . . 629<sup>b</sup> (Beecher)  
   Additions to . . . . . 631<sup>b</sup>  
   Authorship . . . . . 633<sup>a</sup>  
   Contents . . . . . 630<sup>a</sup>  
   Critical estimates . . . . . 632<sup>b</sup>  
   Date . . . . . 633<sup>a</sup>  
   Name . . . . . 629<sup>b</sup>  
   Numbers . . . . . 630<sup>a</sup>  
   Omissions . . . . . 632<sup>a</sup>  
   Position in OT . . . . . 629<sup>b</sup>  
   Purpose of . . . . . 632<sup>b</sup>  
   of Quotations . . . . . 2520<sup>b</sup> (Sweet)  
   Sources . . . . . 630<sup>a</sup>  
   Text . . . . . 632<sup>b</sup>  
   Trustworthiness . . . . . 634<sup>a</sup>  
   Value . . . . . 635<sup>a</sup>  
 Chronology of NT . . . . . 644<sup>b</sup> (Armstrong)  
   Apostolic age . . . . . 647<sup>b</sup>  
   Baptism of Jesus . . . . . 646<sup>b</sup>  
   Birth of Jesus . . . . . 645<sup>a</sup>  
   Captivity of Paul . . . . . 648<sup>b</sup>  
   Conversion of Paul . . . . . 647<sup>b</sup>  
   Death of Jesus . . . . . 647<sup>b</sup>  
   Edict of Claudius . . . . . 648<sup>b</sup>  
   Epistles of Paul . . . . . 649<sup>b</sup>  
   Famine under Claudius . . . . . 648<sup>a</sup>  
   Gallio . . . . . 648<sup>b</sup>  
   of Gospels, Synoptic . . . . . 1284<sup>a</sup> (Iverach)  
   Herod Agrippa . . . . . 648<sup>a</sup>  
   of Jesus Christ (Chro-  
   nology) . . . . . 1628<sup>b</sup>  
   Jews expelled from  
   Rome . . . . . 648<sup>b</sup>  
   Ministry of Jesus . . . . . 646<sup>b</sup>  
   Missionary journeys  
   of Paul . . . . . 649<sup>a</sup>  
   of Passion Week . . . . . 1655<sup>a</sup>; 1658<sup>a</sup> (Orr)  
   of Paul, the Apostle . . . . . 2270<sup>b</sup> (A. T. Robertson)  
   of Pentecost . . . . . 2318<sup>a</sup> (Dosker)  
   Release and death of  
   Paul . . . . . 649<sup>b</sup>  
   St. Peter's death . . . . . 650<sup>a</sup>  
   Sergius Paulus . . . . . 648<sup>a</sup>  
   Synoptic Gospels . . . . . 650<sup>a</sup>  
 Chronology of OT . . . . . 635<sup>a</sup> (Mack)  
   Abraham to Creation . . . . . 643<sup>a</sup>; 139<sup>a</sup> (Davis)  
   of Deluge of Noah . . . . . 821<sup>b</sup> (Wright)  
   Ages between OT and  
   NT . . . . . 636<sup>a</sup>  
   of Ahaziah . . . . . 82<sup>b</sup> (Mosiman)  
   Assyrian period and  
   Judah after fall of  
   Samaria . . . . . 638<sup>a</sup>  
   Babylonian period . . . . . 637<sup>b</sup>  
   Disruption to the exo-  
   dus . . . . . 641<sup>a</sup>  
   Divided kingdom  
   period . . . . . 638<sup>b</sup>  
   Exodus to birth of  
   Abraham . . . . . 642<sup>a</sup>  
   of Menahem . . . . . 2031<sup>b</sup> (Caldecott)  
   Persian period . . . . . 636<sup>b</sup>

- Chronology of OT—*continued*  
 cf Tabernacle . . . . . 2891<sup>a</sup>; 2894<sup>a</sup> (Caldecott;  
 Orr; Whitelaw)  
 cf Zechariah . . . . . 3136<sup>a</sup> (Caldecott)  
 Chrysolite  
 cf Stones, Precious . . . 2856<sup>a</sup> (Fletcher)  
 Chrysoprase, Chryso-  
 prasus  
 cf Stones, Precious . . . 2856<sup>a</sup> (Fletcher)  
 Chub (Cub) . . . . . 765<sup>a</sup>  
 Chun (Cun) . . . . . 765<sup>b</sup>  
 Church . . . . . 650<sup>b</sup> (Lambert)  
 Adoption of term by  
 Jesus . . . . . 651<sup>a</sup>  
 Consecration . . . . . 652<sup>b</sup>  
 Faith . . . . . 652<sup>a</sup>  
 Fellowship . . . . . 652<sup>a</sup>  
 cf Jesus Christ . . . . . 1643<sup>b</sup> (Orr)  
 Organization of . . . . . 653<sup>a</sup>  
 Power . . . . . 652<sup>b</sup>  
 Pre-Christian history  
 of the term . . . . . 651<sup>a</sup>  
 cf Presbyter . . . . . 2437<sup>b</sup> (Mack)  
 Unity . . . . . 652<sup>a</sup>  
 Use of term in NT . . . 651<sup>b</sup>  
 Church of the Brethren  
 cf Lord's Supper  
 (Dunkers) . . . . . 1929<sup>a</sup> (Kurtz)  
 Church Government . . . 653<sup>b</sup> (Forrester)  
 cf Bishop . . . . . 478<sup>b</sup> (Dosker)  
 Coöperative rela-  
 tions . . . . . 655<sup>a</sup>  
 External authority . . . 655<sup>a</sup>  
 cf Government . . . . . 1287<sup>a</sup> (Heidel)  
 Internal order . . . . . 654<sup>a</sup>  
 Meaning . . . . . 654<sup>a</sup>  
 cf Ministry . . . . . 2059<sup>b</sup> (T. M. Lindsay)  
 cf Pauline Theology . . 2289<sup>a</sup> (Easton)  
 Church Officers  
 In Clement . . . . . 1897<sup>b</sup> (Cowan)  
 In Didache . . . . . 1899<sup>a</sup> (Cowan)  
 In Ignatius . . . . . 1900<sup>a</sup> (Cowan)  
 of Literature, Sub-apos. 1896<sup>b</sup> (Cowan)  
 Churches, Robbers of  
 cf Robbers of Temples 2595<sup>b</sup>  
 Churches, Seven  
 cf Angels of the Seven  
 Churches . . . . . 135<sup>b</sup> (Banks)  
 cf Smyrna . . . . . 2818<sup>b</sup> (Banks)  
 Churl . . . . . 655<sup>b</sup> (Sampey)  
 Chushan-rishathaim  
 cf Cushan-rishathaim 768<sup>b</sup> (Baur)  
 Chusi . . . . . 655<sup>b</sup>  
 Chuzas . . . . . 655<sup>b</sup>  
 cf Joanna . . . . . 1679<sup>a</sup> (Kerr)  
 Ciccar . . . . . 655<sup>b</sup>  
 cf Cities of the Plain . . 660<sup>a</sup> (Wright)  
 cf Plain . . . . . 2406<sup>b</sup> (Day)  
 Cidkenu . . . . . 1584<sup>a</sup>  
 Cielod, Cieling  
 cf Ceiled, Ceiling . . . . 587<sup>a</sup> (Berry)  
 Cilicia . . . . . 655<sup>b</sup> (White)  
 Cinnamon . . . . . 656<sup>a</sup> (Masterman)  
 cf Cassia . . . . . 582<sup>a</sup> (Masterman)  
 Cinneroth (Chinnereth) . 611<sup>a</sup>  
 Cirama (Kirama) . . . . . 1811<sup>a</sup>  
 Circle . . . . . 656<sup>b</sup>  
 cf Astronomy . . . . . 300<sup>b</sup> (Maunder)  
 cf Ciccar . . . . . 655<sup>b</sup>; 660<sup>a</sup> (Wright)  
 cf Plain . . . . . 2406<sup>b</sup> (Day)  
 Circle of the Earth  
 cf Astronomy . . . . . 300<sup>b</sup> (Maunder)  
 Circuit . . . . . 656<sup>b</sup> (N. Isaacs)  
 Circumcision . . . . . 656<sup>b</sup> (T. Lewis); 910<sup>b</sup>  
 (Petrie)  
 cf Firstborn, Firstling . 1113<sup>b</sup> (T. Lewis)  
 cf Foreskin . . . . . 1131<sup>b</sup> (Luering)  
 cf Seal . . . . . 2709<sup>b</sup> (Edwards)  
 cf Uncircumcised . . . . 3035<sup>b</sup> (Easton)  
 Cis . . . . . 657<sup>b</sup>  
 Cisai (Kiseus) . . . . . 1813<sup>a</sup>  
 Cistern, Well, Pool,  
 Aqueduct . . . . . 657<sup>b</sup> (A. C. Dickie)  
 cf Fountain . . . . . 1141<sup>b</sup> (Day)  
 cf Pool . . . . . 2419<sup>b</sup> (Day)  
 cf Water . . . . . 3074<sup>a</sup> (Joy)  
 cf Well . . . . . 3081<sup>a</sup> (Day)  
 Citadel  
 cf Fortification . . . . . 1136<sup>b</sup> (Nicol)  
 Cithern . . . . . 660<sup>a</sup> (Millar)  
 cf Music . . . . . 2094<sup>b</sup> (Millar)  
 Cities, Levitical  
 cf City . . . . . 662<sup>a</sup> (A. C. Dickie)  
 of Levitical Cities . . . 1869<sup>a</sup> (Wiener)  
 Cities of the Plain,  
 Ciccar . . . . . 660<sup>a</sup> (Wright)  
 cf Gomorrah . . . . . 1277<sup>a</sup> (Wright)  
 cf Slime, Slime Pits . . . 2817<sup>b</sup> (Day)  
 cf Sodom . . . . . 2821<sup>b</sup> (Wright)  
 Cities of Refuge . . . . . 2545<sup>b</sup> (Ewing)  
 Cities, Store  
 cf City . . . . . 662<sup>a</sup> (A. C. Dickie)  
 Citims (Chittim) . . . . . 1814<sup>b</sup> (Pinches)  
 Citizenship . . . . . 661<sup>a</sup> (Trever)  
 cf Roman Law . . . . . 2611<sup>b</sup> (Allen)  
 Citron  
 cf Apple . . . . . 209<sup>a</sup> (Masterman)  
 City . . . . . 662<sup>a</sup> (A. C. Dickie)  
 Canaanite city . . . . . 662<sup>a</sup>  
 Of Confusion . . . . . 665<sup>a</sup>  
 Of David (Zion) . . . . . 3150<sup>b</sup> (Masterman)  
 Of Destruction . . . . . 665<sup>a</sup> (Orr)  
 cf Fortification . . . . . 1136<sup>b</sup> (Nicol)  
 cf Gate . . . . . 1175<sup>b</sup> (Easton)  
 cf Golden City . . . . . 1275<sup>a</sup>  
 Of Jewish occupation . 663<sup>b</sup>  
 Levitical cities . . . . . 665<sup>a</sup>; 1869<sup>a</sup> (Wiener)  
 cf Refuge, Cities of . 2545<sup>b</sup> (Ewing)  
 Of Palm Trees  
 (Jericho) . . . . . 1592<sup>a</sup> (Wright)  
 Royal (Rabbah) . . . . . 2520<sup>b</sup> (Ewing)  
 Rulers of . . . . . 665<sup>b</sup> (Fortune)  
 cf Salt, City of . . . . . 2664<sup>b</sup>  
 Store cities . . . . . 665<sup>a</sup>

City—*continued*

- Town . . . . . 3001<sup>a</sup> (Christie)  
 Village . . . . . 3049<sup>b</sup> (Christie)  
 Of Waters (Rabbah) . . . . . 2520<sup>b</sup> (Ewing)  
 Clap . . . . . 665<sup>b</sup>  
 Clasps . . . . . 665<sup>b</sup> (Caldecott)  
   of Selvedge . . . . . 2716<sup>b</sup>  
 Claudia (Cauda) . . . . . 584<sup>b</sup> (Calder)  
 Claudia . . . . . 666<sup>a</sup> (Jacobs)  
   of Pudens . . . . . 2501<sup>a</sup> (Rutherford)  
   of Woman . . . . . 3103<sup>a</sup> (Pratt)  
 Claudius . . . . . 666<sup>a</sup> (Hutchison)  
 Claudius Lysias . . . . . 666<sup>b</sup> (Kerr)  
   of Lysias . . . . . 1943<sup>b</sup> (Hutchison)  
   of Tertullus . . . . . 2949<sup>b</sup> (Kerr)  
 Claw . . . . . 667<sup>a</sup>  
 Clay . . . . . 667<sup>a</sup> (Day)  
   of Lime . . . . . 1893<sup>b</sup> (Day)  
 Clean . . . . . 667<sup>b</sup> (Crannell)  
   of Defilement . . . . . 818<sup>a</sup> (Crannell)  
   of Pure, Purely . . . . . 2506<sup>b</sup> (W. L. Walker)  
   of Purity . . . . . 2507<sup>b</sup> (Caverno)  
   of Seed . . . . . 2712<sup>b</sup> (Easton)  
 Clean and Unclean  
   Animals  
     of Abomination . . . . . 16<sup>a</sup> (Eager)  
 Clean and Unclean Food 1121<sup>b</sup> (Eager)  
 Clean and Unclean  
   Meats  
     of Abstinence . . . . . 24<sup>b</sup> (Eager)  
 Cleanse . . . . . 667<sup>b</sup> (Crannell)  
 Clear, Clearness . . . . . 668<sup>b</sup> (Jacobs)  
 Cleave . . . . . 668<sup>b</sup> (Fortune)  
 Cleave Asunder . . . . . 316<sup>b</sup> (S. F. Hunter)  
 Cleft, Cliff, Clift . . . . . 668<sup>b</sup>  
 Clemency . . . . . 668<sup>b</sup>  
 Clement . . . . . 669<sup>a</sup> (Jacobs)  
 Clement of Rome . . . . . 481<sup>a</sup> (Lowndes)  
 Clement, Second Epis-  
   tle of  
     of Literature, Sub-  
       apoc . . . . . 1902<sup>b</sup> (Cowan)  
 Cleopas . . . . . 669<sup>a</sup>  
   of Alphaeus . . . . . 106<sup>a</sup> (Fortune)  
   of Clopas . . . . . 669<sup>b</sup> (Jacobs)  
 Cleopatra . . . . . 669<sup>a</sup> (Hutchison)  
 Cleophas (Clopas) . . . . . 669<sup>b</sup> (Jacobs)  
 Clerk  
   of Townclerk . . . . . 3001<sup>a</sup> (Dosker)  
 Cliff, Clift  
   of Cleft . . . . . 668<sup>b</sup>  
 Cloak, Cloke . . . . . 669<sup>a</sup> (Eager)  
   of Dress . . . . . 875<sup>b</sup> (Eager)  
 Clod . . . . . 669<sup>b</sup> (M. O. Evans)  
 Clopas . . . . . 669<sup>b</sup> (Jacobs)  
   of Alphaeus . . . . . 106<sup>a</sup> (Fortune)  
 Close . . . . . 669<sup>b</sup> (W. L. Walker)  
 Closet . . . . . 669<sup>b</sup> (Estes)  
   of House . . . . . 1434<sup>b</sup> (A. C. Dickie)  
 Cloth, Clothing  
   of Dress . . . . . 875<sup>b</sup> (Eager)  
 Clothed Upon . . . . . 670<sup>a</sup> (Clippinger)  
 Clothes, Rending of . . . . . 670<sup>a</sup> (Fortune)  
 Cloud . . . . . 670<sup>a</sup> (Joy)  
   Jehovah's presence and  
     glory in . . . . . 670<sup>b</sup>  
   In Palestine . . . . . 670<sup>a</sup>  
   Pillar of . . . . . 670<sup>b</sup>  
   Rain . . . . . 670<sup>a</sup>  
   Transitory . . . . . 670<sup>b</sup>  
 Clout . . . . . 671<sup>a</sup>  
 Cloven . . . . . 671<sup>a</sup> (Jacobs)  
 Club  
   of Armor . . . . . 251<sup>a</sup> (Nicol)  
   of Staff . . . . . 2847<sup>b</sup>  
 Cluster . . . . . 671<sup>a</sup> (Masterman)  
 Cnidus . . . . . 671<sup>a</sup> (Banks)  
 Coal . . . . . 671<sup>b</sup> (Day)  
 Coast . . . . . 672<sup>a</sup> (Day)  
   of Island . . . . . 1511<sup>a</sup> (Day)  
   of Quarter . . . . . 2513<sup>a</sup>  
   of Shore . . . . . 2779<sup>b</sup> (Day)  
 Coat  
   of Cloak, Cloke . . . . . 669<sup>a</sup> (Eager)  
   of Coat of Mail . . . . . 253<sup>b</sup> (Nicol)  
   of Dress . . . . . 875<sup>b</sup> (Eager)  
   of Priests and Levites 2446<sup>b</sup> (Wiener)  
 Cock . . . . . 672<sup>a</sup> (Stratton-Porter)  
   of Chicken . . . . . 605<sup>b</sup> (Stratton-Porter)  
 Cockatrice . . . . . 672<sup>b</sup> (Day)  
   of Serpent . . . . . 2736<sup>a</sup> (Day)  
 Cock-crowing . . . . . 672<sup>b</sup>  
   of Cock . . . . . 672<sup>a</sup> (Stratton-Porter)  
 Cocker . . . . . 672<sup>b</sup>  
 Cockle . . . . . 672<sup>b</sup> (Masterman)  
 Code of Hammurabi . . . . . 1327<sup>a</sup> (Ungnad)  
 Codex  
   of Text and Manu-  
     scripts of NT . . . . . 2952<sup>a</sup> (Sitterly)  
 Coele-Syria . . . . . 672<sup>b</sup> (Ewing)  
 Coenaculum  
   of Jerusalem . . . . . 1613<sup>a</sup> (Masterman)  
 Coffe . . . . . 673<sup>a</sup>  
 Coffin  
   of Burial . . . . . 529<sup>a</sup> (Eager)  
   of Chest . . . . . 605<sup>a</sup> (Eager)  
 Cogitation . . . . . 673<sup>a</sup>  
 Cohort . . . . . 673<sup>a</sup>  
   of Band . . . . . 382<sup>a</sup> (Nicol; Rees)  
 Coins . . . . . 673<sup>a</sup> (Porter)  
   of Money . . . . . 2076<sup>a</sup> (Porter)  
   of Phoenicia . . . . . 2388<sup>b</sup> (Porter)  
   of Sidon . . . . . 2786<sup>a</sup> (Porter)  
   of Weights and Meas-  
     ures . . . . . 3081<sup>a</sup> (Porter)  
 Cola (Chola) . . . . . 612<sup>b</sup>  
 Cold . . . . . 673<sup>b</sup> (Joy)  
   of Seasons . . . . . 2710<sup>b</sup> (Joy)  
 Col-hozeh . . . . . 674<sup>a</sup>  
 Colius  
   of Calitas . . . . . 545<sup>b</sup> (Edwards)  
 Collar . . . . . 674<sup>a</sup> (N. Isaacs)  
 Collection . . . . . 674<sup>a</sup> (Trevor)  
   of Communion . . . . . 688<sup>b</sup> (Miller)

- College . . . . . 674<sup>a</sup>  
   of Mishneh . . . . . 2066<sup>b</sup> (Masterman)  
 Collop . . . . . 674<sup>b</sup>  
 Colony . . . . . 674<sup>b</sup> (Heidel)  
   of Citizenship . . . . . 661<sup>a</sup> (Trever)  
   of Philippi . . . . . 2369<sup>a</sup> (Tod)  
 Color, Colors . . . . . 674<sup>b</sup> (Patch)  
   Bay . . . . . 675<sup>a</sup>  
   Black . . . . . 675<sup>a</sup>  
   Blue . . . . . 675<sup>b</sup>  
   Brown . . . . . 675<sup>b</sup>  
   Crimson . . . . . 675<sup>b</sup>  
   of Dye, Dyeing . . . . . 883<sup>b</sup> (Patch)  
   Gray . . . . . 675<sup>b</sup>  
   Green . . . . . 675<sup>b</sup>  
   Hoar . . . . . 675<sup>b</sup>  
   of Paint . . . . . 2208<sup>a</sup> (Crannell)  
   Purple . . . . . 675<sup>b</sup>; 2509<sup>b</sup> (Day)  
   Red . . . . . 675<sup>b</sup>  
   Scarlet . . . . . 676<sup>a</sup>  
   Sorrel . . . . . 676<sup>a</sup>  
     of Sorrel . . . . . 2836<sup>b</sup>  
   Vermilion . . . . . 676<sup>a</sup>  
   White . . . . . 676<sup>a</sup>  
   of Worm, Scarlet-worm 3109<sup>a</sup> (Day)  
   Yellow . . . . . 676<sup>a</sup>  
 Colossae . . . . . 676<sup>b</sup> (Banks)  
 Colossians, Epistle to the 676<sup>b</sup> (C. S. Lewis)  
   Argument . . . . . 678<sup>a</sup>  
   Authenticity . . . . . 676<sup>b</sup>  
   Destination . . . . . 677<sup>a</sup>  
   Internal evidence . . . . . 677<sup>a</sup>  
   of Laodiceans, Epistle  
     to the . . . . . 1837<sup>a</sup> (Rutherford)  
   of Philemon, Epistle  
     to . . . . . 2366<sup>b</sup> (C. S. Lewis)  
   Place and date . . . . . 677<sup>a</sup>  
   Purpose . . . . . 677<sup>b</sup>  
   Relation to other NT  
     writings . . . . . 677<sup>b</sup>  
 Colt . . . . . 678<sup>a</sup> (Day)  
 Come . . . . . 678<sup>b</sup> (W. L. Walker)  
 Comeliness . . . . . 678<sup>b</sup>  
 Comfort . . . . . 678<sup>b</sup> (Jacobs)  
 Comfortably . . . . . 678<sup>b</sup> (Pratt)  
 Comforter . . . . . 679<sup>a</sup> (Mullins)  
   of Advocate . . . . . 65<sup>a</sup> (Mullins)  
   of Holy Spirit . . . . . 1406<sup>a</sup> (Mullins)  
   of Paraclete . . . . . 2245<sup>a</sup> (Mullins)  
 Comfortless . . . . . 679<sup>a</sup> (Pratt)  
 Coming of Christ  
   of Desire of All Nations 832<sup>b</sup> (Gray)  
   of Parousia . . . . . 2249<sup>a</sup> (Easton)  
 Coming, Second  
   of Parousia . . . . . 2249<sup>a</sup> (Easton)  
 Commandment . . . . . 679<sup>b</sup> (Jacobs)  
   of Precept . . . . . 2434<sup>b</sup> (Edwards)  
   of Ten Command-  
     ments . . . . . 2944<sup>b</sup> (Sampey)  
 Commandment, The  
   New . . . . . 679<sup>b</sup> (Rees)  
   of Brotherly Love . . . . . 525<sup>b</sup> (Rees)  
 Commandments, The  
   Ten . . . . . 2944<sup>b</sup> (Sampey)  
 Commandments and the  
   Family . . . . . 1095<sup>b</sup> (Caverno)  
 Commend . . . . . 680<sup>a</sup> (Jacobs)  
 Commentaries . . . . . 680<sup>b</sup> (Orr)  
   Differences in char-  
     acter . . . . . 681<sup>a</sup>  
   Hebrew . . . . . 685<sup>a</sup> (Oko)  
   Meaning of term . . . . . 680<sup>b</sup>  
   Range of . . . . . 681<sup>a</sup>  
 Commentary . . . . . 687<sup>a</sup> (M. O. Evans)  
   of Chronicles, Books  
     of . . . . . 629<sup>b</sup> (Beecher)  
   of Midrash . . . . . 2050<sup>a</sup>  
 Commerce . . . . . 687<sup>b</sup> (Pollard)  
   of Phoenicia . . . . . 2388<sup>b</sup> (Porter)  
   of Stranger and So-  
     journer in the OT . . . . . 2865<sup>a</sup> (Wiener)  
   of Trade . . . . . 3002<sup>a</sup> (Easton)  
 Commission, Great  
   of Jesus Christ . . . . . 1666<sup>b</sup> (Orr)  
 Commit . . . . . 688<sup>a</sup> (W. L. Walker)  
 Commodious . . . . . 688<sup>a</sup>  
 Common . . . . . 688<sup>a</sup> (Jacobs)  
 Commonwealth . . . . . 688<sup>b</sup>  
   of Citizenship . . . . . 661<sup>a</sup> (Trever)  
 Commune . . . . . 688<sup>b</sup>  
   of Communion . . . . . 688<sup>b</sup> (Miller)  
 Communicate . . . . . 688<sup>b</sup>  
 Communication . . . . . 688<sup>b</sup>  
 Communion . . . . . 688<sup>b</sup> (Miller)  
   Fellowship — Almsgiv-  
     ing . . . . . 689<sup>a</sup>  
   Fellowship—Communi-  
     nity . . . . . 689<sup>a</sup>  
   Fellowship—Coöper-  
     ation . . . . . 689<sup>a</sup>  
   Fellowship in Holy  
     Eucharist . . . . . 688<sup>b</sup>  
   Fellowship of the Holy  
     Spirit . . . . . 689<sup>a</sup>  
   of Lord's Supper . . . . . 1921<sup>b</sup> (Gummey; Dosker;  
     Dau; Kurtz)  
 Communion with De-  
   mons . . . . . 689<sup>b</sup> (Sweet)  
   of Familiar . . . . . 1094<sup>a</sup> (Pollard)  
   of Night-monster . . . . . 2143<sup>b</sup> (Sweet)  
 Community of Goods . . . . . 690<sup>b</sup> (Jacobs)  
 Compact . . . . . 691<sup>a</sup> (W. L. Walker)  
 Company . . . . . 691<sup>a</sup> (Pratt)  
 Comparative Religion . . . . . 691<sup>b</sup> (Tisdall)  
 Compare . . . . . 694<sup>b</sup> (W. L. Walker)  
 Compass . . . . . 694<sup>b</sup> (W. L. Walker)  
   of Tools . . . . . 2999<sup>a</sup> (Easton)  
 Compassion . . . . . 695<sup>a</sup> (W. L. Walker)  
   of Pity . . . . . 2402<sup>b</sup> (W. L. Walker)  
 Compel . . . . . 695<sup>b</sup> (Trever)  
 Complaining . . . . . 695<sup>b</sup>  
 Complete . . . . . 695<sup>b</sup>  
 Composition . . . . . 695<sup>b</sup>  
 Comprehend . . . . . 695<sup>b</sup> (Pratt)

- Conaniah . . . . . 696<sup>a</sup>  
 Conceal . . . . . 696<sup>a</sup>  
 Conceit . . . . . 696<sup>a</sup>  
 Conception, Conceive . . . 696<sup>a</sup>  
   cf Immaculate Con-  
   ception . . . . . 1456<sup>b</sup> (Sweet)  
 Concerning . . . . . 696<sup>a</sup> (W. L. Walker)  
 Concision . . . . . 696<sup>b</sup>  
   cf Circumcision . . . . . 910<sup>b</sup> (Petrie)  
   cf Foreskin . . . . . 1131<sup>b</sup> (Lueling)  
   cf Member . . . . . 2030<sup>a</sup> (Lueling)  
 Conclude . . . . . 696<sup>b</sup>  
 Conclusion . . . . . 696<sup>b</sup>  
 Concordance . . . . . 696<sup>b</sup> (Orr)  
 Concourse . . . . . 697<sup>b</sup>  
 Concubinage  
   cf Family . . . . . 1094<sup>b</sup> (Caverno)  
 Concupiscence . . . . . 698<sup>a</sup> (Jacobs)  
 Condemn, Condemna-  
   tion . . . . . 698<sup>a</sup> (Trevor)  
 Condensation of Christ  
   cf Kenosis . . . . . 1792<sup>a</sup> (Easton)  
 Condiments . . . . . 1124<sup>a</sup> (Eager)  
 Conduct  
   cf Ethics . . . . . 1013<sup>a</sup> (Alexander)  
 Conduit  
   cf Cistern . . . . . 657<sup>b</sup> (A. C. Dickie)  
 Coney . . . . . 698<sup>b</sup> (Day)  
   cf Rock-badger . . . . . 2596<sup>b</sup>  
 Confection, Confection-  
   ary . . . . . 699<sup>a</sup>  
   cf Perfume . . . . . 2321<sup>b</sup> (Patch)  
 Confederate, Confeder-  
   acy . . . . . 699<sup>a</sup> (W. L. Walker)  
 Confer, Conference . . . . . 699<sup>a</sup>  
 Confession . . . . . 699<sup>a</sup> (Jacobs)  
 Confidence . . . . . 700<sup>a</sup> (W. L. Walker)  
 Confirm, Confirmation . . . 700<sup>a</sup> (Jacobs)  
   cf Hands, Imposition of 1335<sup>a</sup> (Orr)  
 Confiscation  
   cf Punishments . . . . . 2504<sup>b</sup> (Hirsch)  
 Conflict . . . . . 700<sup>b</sup>  
   cf Agony . . . . . 71<sup>b</sup> (Pratt)  
 Conform . . . . . 700<sup>b</sup>  
 Confound . . . . . 700<sup>b</sup> (W. L. Walker)  
 Confusion . . . . . 700<sup>b</sup> (W. L. Walker)  
 Confusion of Tongues . . . . 2994<sup>b</sup> (Easton)  
   cf Babel, Tower of . . . . . 355<sup>b</sup> (Pinches)  
 Congregation . . . . . 700<sup>b</sup> (Wiener)  
   cf Convocation . . . . . 708<sup>a</sup> (Wiener)  
   cf Feasts and Fasts . . . . . 1103<sup>a</sup> (E. D. Isaacs)  
   Mount of . . . . . 701<sup>a</sup> (Orr)  
   cf Tabernacle . . . . . 2887<sup>b</sup> (Caldecott; Orr)  
 Coniah . . . . . 701<sup>a</sup>  
   cf Jehoiachin . . . . . 1577<sup>a</sup> (Genung)  
   cf Servant of Jehovah . . . . . 2739<sup>a</sup> (Hough)  
 Cononiah  
   cf Conaniah . . . . . 696<sup>a</sup>  
 Conqueror . . . . . 701<sup>a</sup> (Jacobs)  
 Conscience . . . . . 701<sup>b</sup> (Stalker)  
   Antecedent . . . . . 702<sup>a</sup>  
   Education of . . . . . 702<sup>b</sup>  
 Conscience—*continued*  
   History and literature . . . . 703<sup>a</sup>  
   Institutional and asso-  
   ciational theories . . . . . 702<sup>a</sup>  
   Sequent  
     Judicial . . . . . 701<sup>b</sup>  
     Predictive . . . . . 701<sup>b</sup>  
     Punitive . . . . . 701<sup>b</sup>  
     Social . . . . . 701<sup>b</sup>  
   cf Spirit . . . . . 2841<sup>b</sup> (Marais)  
 Consecrate, Consecra-  
   tion . . . . . 703<sup>b</sup> (Rees)  
   cf Ban (Curse) . . . . . 767<sup>a</sup> (T. Lewis)  
   cf Holiness . . . . . 1403<sup>b</sup> (Lambert)  
   cf Nazirite . . . . . 2124<sup>a</sup> (Christie)  
 Consent . . . . . 704<sup>a</sup> (Jacobs)  
 Consider . . . . . 704<sup>a</sup> (Jacobs)  
 Consist . . . . . 704<sup>a</sup>  
 Consolation . . . . . 704<sup>a</sup>  
   cf Barnabas . . . . . 405<sup>b</sup> (Jacobs)  
   cf Comfort . . . . . 673<sup>b</sup> (Jacobs)  
 Consort . . . . . 704<sup>a</sup>  
 Conspiracy  
   cf Confederacy . . . . . 699<sup>a</sup> (W. L. Walker)  
 Constant, Constantly . . . . 704<sup>b</sup>  
 Constellations  
   cf Astronomy . . . . . 309<sup>a</sup> (Maunder)  
 Constrain . . . . . 704<sup>b</sup>  
   cf Compel . . . . . 695<sup>b</sup> (Trevor)  
 Consult . . . . . 704<sup>b</sup> (Fortune)  
   cf Astrology . . . . . 295<sup>b</sup> (Maunder)  
   cf Communion with  
     Demons . . . . . 689<sup>b</sup> (Sweet)  
     cf Divination . . . . . 860<sup>a</sup> (T. W. Davies)  
 Consume . . . . . 704<sup>b</sup> (W. L. Walker)  
 Consummation . . . . . 704<sup>b</sup> (Clippinger)  
 Consumption . . . . . 705<sup>a</sup>  
 Contain  
   cf Contingency . . . . . 705<sup>a</sup> (Rees)  
 Contend, Contention . . . . . 705<sup>a</sup> (Jacobs)  
 Content, Contentment . . . . 705<sup>a</sup>  
 Contingency . . . . . 705<sup>a</sup> (Rees)  
   cf Temperance . . . . . 2929<sup>b</sup> (Jacobs)  
 Continual, Continually . . . . 705<sup>a</sup> (Jacobs)  
 Continuance . . . . . 705<sup>b</sup>  
 Contradiction . . . . . 705<sup>b</sup>  
 Contrary . . . . . 705<sup>b</sup> (Clippinger)  
 Contribution . . . . . 705<sup>b</sup> (Jacobs)  
 Contrite, Contrition . . . . . 706<sup>a</sup> (Jacobs)  
 Controversy . . . . . 706<sup>a</sup> (Jacobs)  
 Convenient . . . . . 706<sup>a</sup> (Jacobs)  
 Convent . . . . . 706<sup>a</sup> (Fortune)  
 Conversant . . . . . 706<sup>a</sup>  
 Conversation . . . . . 706<sup>a</sup> (Trevor)  
 Conversion . . . . . 706<sup>b</sup> (Nuelsen)  
   cf Paul . . . . . 2278<sup>b</sup> (A. T. Robertson)  
   cf Regeneration . . . . . 2549<sup>b</sup> (Nuelsen)  
   cf Repentance . . . . . 2553<sup>a</sup> (DeMent)  
 Convict, Conviction . . . . . 707<sup>b</sup> (Jacobs)  
 Convince . . . . . 708<sup>a</sup>  
   cf Convict . . . . . 707<sup>b</sup> (Jacobs)  
 Convocation . . . . . 708<sup>a</sup> (Wiener)

- Convulsing  
   of Demon, Demoniac. 827<sup>a</sup> (Sweet)
- Cooking  
   of Food . . . . . 1121<sup>b</sup> (Eager)
- Cool . . . . . 708<sup>a</sup>
- Coos (Cos) . . . . . 723<sup>a</sup> (Harry)
- Coping  
   of House . . . . . 1434<sup>b</sup> (A. C. Dickie)
- Copper . . . . . 708<sup>a</sup> (Patch)  
   of Metals . . . . . 2044<sup>a</sup> (Patch)  
   of Mine, Mining . . . . . 2056<sup>b</sup> (Patch)
- Coppersmith . . . . . 708<sup>b</sup>  
   of Copper . . . . . 708<sup>a</sup> (Patch)
- Coptic Versions . . . . . 708<sup>b</sup> (Tisdall)
- Cor . . . . . 709<sup>a</sup>  
   of Weights and Measures . . . . . 3079<sup>a</sup> (Porter)
- Coral . . . . . 709<sup>a</sup> (Day)
- Cor-ashan . . . . . 709<sup>b</sup>  
   of Ashan . . . . . 267<sup>a</sup>
- Corban . . . . . 709<sup>b</sup> (Baur)  
   of Treasure . . . . . 3007<sup>b</sup> (Raffety)
- Corbe (Chorbe) . . . . . 614<sup>a</sup>
- Cord . . . . . 709<sup>b</sup> (Eager)  
   of Rope . . . . . 2623<sup>b</sup> (Easton)
- Cords, Small . . . . . 710<sup>a</sup>
- Core (Korah) . . . . . 1816<sup>b</sup> (Beecher)
- Coriander . . . . . 710<sup>a</sup>; 1124<sup>a</sup> (Eager)  
   of Food . . . . . 1121<sup>b</sup> (Eager)
- Corinth . . . . . 710<sup>a</sup> (Harry)  
   of Achaicus . . . . . 35<sup>b</sup>
- Corinthians  
   First Epistle to . . . . . 711<sup>b</sup> (Shaw); 466<sup>a</sup> (Orr)  
     Authenticity of . . . . . 711<sup>b</sup>  
     Contents of . . . . . 714<sup>a</sup>  
     Date . . . . . 713<sup>b</sup>  
     Distinguishing features . . . . . 715<sup>a</sup>  
     Occasion of . . . . . 713<sup>b</sup>  
     Paul's previous relations with Corinth 713<sup>a</sup>  
     Relations to Galatians . . . . . 1158<sup>b</sup> (G. G. Findlay)  
     Text . . . . . 713<sup>a</sup>  
   Second Epistle to . . . . . 716<sup>a</sup> (Shaw)  
     Authenticity and date . . . . . 716<sup>a</sup>  
     Contents . . . . . 718<sup>b</sup>  
     Historical reconstruction . . . . . 718<sup>a</sup>  
     Integrity . . . . . 718<sup>a</sup>  
     New situation . . . . . 717<sup>a</sup>  
     Relations to Galatians . . . . . 1158<sup>b</sup> (G. G. Findlay)  
     Resumé of events . . . . . 716<sup>b</sup>  
     Value . . . . . 720<sup>a</sup>
- Corinthus . . . . . 720<sup>b</sup>  
   of Corinth . . . . . 710<sup>a</sup> (Harry)
- Cormorant . . . . . 720<sup>b</sup> (Stratton-Porter)
- Corn . . . . . 720<sup>b</sup> (Masterman)  
   of Agriculture . . . . . 75<sup>b</sup> (Patch)
- Corn—*continued*  
   of Food . . . . . 1122<sup>a</sup> (Eager)  
   of Wheat . . . . . 3082<sup>b</sup> (Masterman)
- Cornelius . . . . . 721<sup>a</sup> (Trever)  
   of Army, Roman . . . . . 257<sup>a</sup> (Allen)
- Corner . . . . . 721<sup>b</sup> (W. L. Walker)
- Corner Gate  
   of Jerusalem . . . . . 1603<sup>a</sup> (Masterman)
- Corners of the Earth . . . . . 887<sup>a</sup> (Maunder)  
   of Astronomy . . . . . 300<sup>b</sup> (Maunder)
- Corner-stone . . . . . 721<sup>b</sup> (Mack)  
   of Canaan . . . . . 549<sup>a</sup> (Sayce)  
   of Fortification . . . . . 1136<sup>b</sup> (Nicol)  
   of House . . . . . 1434<sup>b</sup> (A. C. Dickie)
- Cornet  
   of Music . . . . . 2094<sup>b</sup> (Millar)
- Cornfloor . . . . . 722<sup>a</sup>  
   of Threshing-floor . . . . . 2975<sup>b</sup> (Patch)
- Coronation . . . . . 722<sup>a</sup>
- Corpse . . . . . 722<sup>b</sup> (Luering)  
   of Burial . . . . . 529<sup>a</sup> (Eager)
- Correction . . . . . 722<sup>b</sup> (W. W. Davies)
- Corruption . . . . . 722<sup>b</sup> (Luering)  
   Mount of . . . . . 723<sup>a</sup> (Ewing)
- Cos . . . . . 723<sup>a</sup> (Harry)  
   of Samos . . . . . 2674<sup>b</sup> (Kinsella)
- Cosam . . . . . 723<sup>a</sup>
- Cosmogony  
   of Anthropology . . . . . 144<sup>b</sup> (Marais)  
   of Creation . . . . . 738<sup>a</sup> (J. Lindsay)  
   of Earth . . . . . 887<sup>a</sup> (Day)  
   of Evolution . . . . . 1043<sup>b</sup> (Zenos)  
   of Sky . . . . . 2814<sup>b</sup> (Day)  
   of World, Cosmological 3106<sup>a</sup> (Orr)
- Cosmology  
   of Providence . . . . . 2476<sup>b</sup> (Tillett)  
   of World, Cosmological 3106<sup>a</sup> (Orr)
- Costliness . . . . . 723<sup>a</sup>
- Cotes  
   of Sheepte . . . . . 2757<sup>b</sup> (Patch)
- Cottage  
   of House . . . . . 1434<sup>b</sup> (A. C. Dickie)
- Cotton . . . . . 723<sup>a</sup> (Masterman)
- Couch . . . . . 723<sup>b</sup> (M. O. Evans)  
   of Abel . . . . . 5<sup>a</sup> (M. O. Evans)  
   of Abyss . . . . . 26<sup>b</sup> (T. Lewis)  
   of Bed . . . . . 421<sup>b</sup> (Eager)  
   of Cain . . . . . 538<sup>b</sup> (Farr)
- Couching-place . . . . . 723<sup>b</sup>
- Coulter  
   of Plow . . . . . 2409<sup>a</sup> (Patch)
- Council, Councillor . . . . . 723<sup>b</sup>  
   of Sanhedrin . . . . . 2688<sup>b</sup> (Levertoff)
- Counsel, Counsellor . . . . . 723<sup>b</sup>
- Count . . . . . 723<sup>b</sup>
- Countenance . . . . . 723<sup>b</sup> (Luering)  
   of Face . . . . . 1085<sup>b</sup> (Luering)
- Counter-charm  
   of Amulet . . . . . 126<sup>b</sup> (T. W. Davies)  
   of Charm . . . . . 597<sup>b</sup> (T. W. Davies)
- Counterfeit . . . . . 724<sup>a</sup> (W. L. Walker)
- Countervail . . . . . 724<sup>a</sup>



- Country . . . . . 724<sup>a</sup> (Day)  
 of Hill . . . . . 1392<sup>a</sup> (Masterman)  
 of Land . . . . . 1826<sup>b</sup> (Day)  
 of Lowland . . . . . 1934<sup>b</sup> (Day)  
 of Natural Features . . . . . 2122<sup>a</sup> (Day)  
 Countryman . . . . . 724<sup>b</sup>  
 of Cousin . . . . . 727<sup>a</sup>  
 of Kinsman . . . . . 1810<sup>a</sup> (Pollard)  
 Couple . . . . . 724<sup>b</sup>  
 Coupling . . . . . 724<sup>b</sup>  
 Courage . . . . . 724<sup>b</sup>  
 Course . . . . . 724<sup>b</sup> (Heidel)  
 of Wheel . . . . . 3082<sup>b</sup> (Easton)  
 Course of Priests and Levites . . . . . 2446<sup>b</sup> (Wiener)  
 Court  
 of Gate, East . . . . . 1176<sup>b</sup> (Caldecott)  
 of House . . . . . 1434<sup>b</sup> (A. C. Dickie)  
 Court of the Gentiles  
 of Temple, Herod's . . . . . 2937<sup>a</sup> (Caldecott; Orr)  
 Court of the Sabbath  
 of Covered Way . . . . . 733<sup>a</sup> (Hirsch)  
 Court of the Sanctuary . . . . . 725<sup>a</sup> (Caldecott)  
 Ezekiel's temple . . . . . 725<sup>b</sup>  
 Herod's temple . . . . . 725<sup>b</sup>  
 Solomon's temple . . . . . 725<sup>a</sup>  
 of Tabernacle . . . . . 2889<sup>b</sup> (Caldecott; Orr)  
 of Temple . . . . . 2932<sup>b</sup> (Caldecott; Orr)  
 Courts, Judicial . . . . . 725<sup>b</sup> (Hirsch)  
 of Doctor . . . . . 866<sup>b</sup>  
 of Lawyer . . . . . 1859<sup>a</sup> (Hirsch)  
 of Sanhedrin . . . . . 2688<sup>b</sup> (Levertoff)  
 of Scribes . . . . . 2704<sup>b</sup> (Hirsch)  
 Cousin . . . . . 727<sup>a</sup>  
 of Kinsman . . . . . 1810<sup>a</sup> (Pollard)  
 Coutha (Cutha) . . . . . 770<sup>a</sup>  
 Covenant . . . . . 727<sup>a</sup> (Berry)  
 of Alliance . . . . . 98<sup>b</sup> (Cohon)  
 Among men . . . . . 727<sup>a</sup> (Berry)  
 of Ark of . . . . . 242<sup>b</sup> (Lotz)  
 Between God and men . . . . . 728<sup>a</sup> (Berry)  
 Book of . . . . . 729<sup>b</sup> (Mack)  
 of Law in OT . . . . . 1852<sup>a</sup> (Rule)  
 The new . . . . . 731<sup>a</sup> (M'Caig)  
 of Christ's use at Last Supper . . . . . 731<sup>a</sup>  
 Contrast of old and new in 2 Cor. . . . . 733<sup>a</sup>  
 To Ezekiel . . . . . 732<sup>b</sup>  
 "Inheritance" and "Testament" . . . . . 732<sup>a</sup>  
 Mediator of . . . . . 732<sup>a</sup>  
 New v. old . . . . . 731<sup>a</sup>  
 Relation to Ex 24 . . . . . 731<sup>b</sup>  
 Relation to Jer 31  
 31-34 . . . . . 732<sup>b</sup>  
 Use in Ep. to Hebrews . . . . . 731<sup>b</sup>  
 In NT . . . . . 729<sup>a</sup> (Estes)  
 of Testament . . . . . 2950<sup>a</sup>  
 In OT . . . . . 727<sup>a</sup> (Berry)  
 of Philosophy . . . . . 2384<sup>b</sup> (Rees)
- Covenant—*continued*  
 Of Salt . . . . . 729<sup>b</sup> (Pollard)  
 of Salt . . . . . 2664<sup>a</sup> (Patch)  
 Cover . . . . . 733<sup>a</sup> (Stearns)  
 Coverdale, Miles . . . . . 948<sup>a</sup> (Hutchison)  
 Covered Way . . . . . 733<sup>a</sup> (Hirsch)  
 Covering for the Head . . . . . 733<sup>a</sup> (Eager)  
 Covert . . . . . 733<sup>b</sup>  
 Covet . . . . . 733<sup>b</sup>  
 Covetousness . . . . . 733<sup>b</sup> (W. Evans)  
 of Family . . . . . 1094<sup>b</sup> (Caverno)  
 Cow . . . . . 734<sup>a</sup> (Day)  
 of Calf . . . . . 542<sup>a</sup> (Day)  
 of Cattle . . . . . 583<sup>b</sup> (Day)  
 Coz . . . . . 734<sup>a</sup>  
 Cozbi . . . . . 734<sup>a</sup>  
 Cozeba  
 of Achzib . . . . . 37<sup>b</sup> (Mack)  
 Cracknel . . . . . 734<sup>b</sup>  
 Craft, Craftiness, Crafty . . . . . 734<sup>a</sup> (Jacobs)  
 Crafts . . . . . 734<sup>a</sup> (Patch)  
 Brickmaking . . . . . 735<sup>a</sup>  
 of Brick . . . . . 520<sup>b</sup> (Patch)  
 Ceramics . . . . . 735<sup>b</sup>  
 of Potter, Pottery . . . . . 2423<sup>b</sup> (Patch)  
 Dyeing and Cleansing . . . . . 735<sup>b</sup>  
 of Color . . . . . 674<sup>b</sup> (Patch)  
 of Dye, Dyeing . . . . . 883<sup>b</sup> (Patch)  
 of Fuller . . . . . 1148<sup>a</sup> (Patch)  
 Engraving . . . . . 735<sup>b</sup>  
 of Carving . . . . . 581<sup>b</sup> (Patch)  
 Glass-making . . . . . 736<sup>a</sup>  
 of Glass . . . . . 1233<sup>a</sup> (Porter)  
 of Goldsmith . . . . . 1275<sup>a</sup> (Patch)  
 Grinding . . . . . 736<sup>a</sup>  
 of Mill, Millstone . . . . . 2052<sup>a</sup> (Patch)  
 of Iron . . . . . 1492<sup>a</sup> (Patch)  
 Mason work . . . . . 736<sup>a</sup>  
 of Mason . . . . . 2007<sup>a</sup>  
 of Mill, Millstone . . . . . 2052<sup>a</sup> (Patch)  
 Mining . . . . . 736<sup>a</sup>  
 of Metals . . . . . 2044<sup>a</sup> (Patch)  
 of Mine, Mining . . . . . 2056<sup>b</sup> (Patch)  
 Needle-work . . . . . 735<sup>b</sup>  
 of Embroidering . . . . . 940<sup>a</sup> (Patch)  
 Oil-making . . . . . 736<sup>a</sup>  
 of Oil . . . . . 2181<sup>b</sup> (Patch)  
 Painting . . . . . 736<sup>a</sup>  
 Paper-making . . . . . 736<sup>b</sup>  
 Perfume-making . . . . . 736<sup>b</sup>  
 of Perfume . . . . . 2321<sup>b</sup> (Patch)  
 of Potter, Pottery . . . . . 2423<sup>b</sup> (Patch)  
 Spinning and weaving . . . . . 736<sup>b</sup>  
 of Spinning . . . . . 2841<sup>a</sup> (Patch)  
 of Weaving . . . . . 3077<sup>a</sup> (Patch)  
 Tanning . . . . . 736<sup>b</sup>  
 of Tanner . . . . . 2908<sup>b</sup> (Patch)  
 of Tent-maker . . . . . 2948<sup>a</sup>  
 Tent-making . . . . . 736<sup>b</sup>  
 of Tent . . . . . 2947<sup>b</sup> (Patch)  
 of Tools . . . . . 2998<sup>b</sup> (Easton)  
 of Wine . . . . . 3086<sup>b</sup> (Easton)

Crafts—*continued*

- Wine-making . . . . . 736<sup>b</sup>  
 of Wine Press . . . . . 3086<sup>a</sup> (Easton)  
 Wood-working . . . . . 735<sup>a</sup>  
 of Carpenter . . . . . 580<sup>a</sup>  
 of Tools . . . . . 2998<sup>b</sup> (Easton)  
 Craftsman . . . . . 737<sup>a</sup> (Patch)  
 Crag . . . . . 737<sup>a</sup> (Day)  
 of Rock . . . . . 2596<sup>a</sup> (Day)  
 Crane . . . . . 737<sup>a</sup> (Stratton-Porter)  
 Crashing . . . . . 737<sup>b</sup>  
 Crates . . . . . 738<sup>a</sup>  
 Creation . . . . . 738<sup>a</sup> (J. Lindsay)  
 of Anthropology . . . . . 144<sup>b</sup> (Marais)  
 of Earth . . . . . 887<sup>a</sup> (Day)  
 Evolution . . . . . 739<sup>a</sup>  
 Genesis cosmogony . . . . . 738<sup>b</sup>  
 of World, Cosmo-  
 logical . . . . . 3106<sup>a</sup> (Orr)  
 Creator . . . . . 740<sup>a</sup> (J. Lindsay)  
 Creature . . . . . 740<sup>b</sup> (Day)  
 Living . . . . . 740<sup>b</sup> (W. L. Walker);  
 1906<sup>a</sup> (Day)  
 Credit . . . . . 741<sup>a</sup>  
 Creditor . . . . . 741<sup>a</sup> (Betteridge)  
 of Debt . . . . . 814<sup>a</sup> (W. Evans)  
 Creed . . . . . 741<sup>a</sup> (Alexander)  
 Historical Forms  
 Apostles' Creed . . . . . 742<sup>b</sup>  
 Athanasian Creed . . . . . 743<sup>a</sup>  
 of Light . . . . . 1891<sup>b</sup> (Pratt)  
 Nicene Creed . . . . . 742<sup>b</sup>  
 Reformation Creeds . . . . . 743<sup>b</sup>  
 Scriptural Basis . . . . . 741<sup>a</sup>  
 Creek . . . . . 743<sup>b</sup>  
 of Melita . . . . . 2029<sup>b</sup> (Allen)  
 Creeping Thing . . . . . 743<sup>b</sup> (Day)  
 of Insects . . . . . 1473<sup>a</sup> (Day)  
 of Locust . . . . . 1907<sup>b</sup> (Day)  
 Cremation . . . . . 744<sup>a</sup> (Eager); 530<sup>a</sup> (Eager)  
 Crescents . . . . . 744<sup>a</sup>  
 of Moon . . . . . 2081<sup>a</sup> (Schenk)  
 of Tires, Round . . . . . 2986<sup>a</sup>  
 Crete . . . . . 744<sup>b</sup> (Calder)  
 of Caphtor . . . . . 568<sup>a</sup> (Ewing)  
 of Cherehites . . . . . 603<sup>a</sup> (Ewing)  
 of Fair Havens . . . . . 1087<sup>b</sup>  
 of Gortyna . . . . . 1280<sup>a</sup>  
 of Phoenix . . . . . 2391<sup>a</sup> (Calder)  
 Crib . . . . . 745<sup>b</sup>  
 Cricket . . . . . 745<sup>b</sup>  
 of Beetle . . . . . 425<sup>a</sup> (Day)  
 of Insects . . . . . 1473<sup>a</sup> (Day)  
 of Locust . . . . . 1907<sup>b</sup> (Day)  
 Crier . . . . . 745<sup>b</sup> (Eager)  
 Crime . . . . . 745<sup>b</sup> (Hirsch)  
 Adultery . . . . . 746<sup>a</sup>  
 of Adultery . . . . . 63<sup>a</sup> (Margolis)  
 Assassination . . . . . 746<sup>a</sup>  
 of Assassination . . . . . 288<sup>a</sup> (Hirsch)

Crime—*continued*

- Bestiality . . . . . 746<sup>a</sup>  
 Blasphemy . . . . . 746<sup>a</sup>  
 of Blasphemy . . . . . 485<sup>b</sup> (Rees)  
 Breach of covenant . . . . . 746<sup>a</sup>  
 Breach of ritual . . . . . 746<sup>a</sup>  
 of Breach of Trust . . . . . 3025<sup>a</sup>  
 of Bribery . . . . . 520<sup>b</sup> (Kaiser)  
 Burglary . . . . . 746<sup>a</sup>  
 of Debt . . . . . 814<sup>a</sup> (W. Evans)  
 of Deception . . . . . 816<sup>a</sup> (Farr)  
 of Dishonesty . . . . . 854<sup>b</sup>  
 of Disobedience . . . . . 854<sup>b</sup> (Clippinger)  
 of Divination . . . . . 860<sup>a</sup> (T. W. Davies)  
 of Drunkenness . . . . . 880<sup>b</sup> (Edwards)  
 Falsehood . . . . . 746<sup>b</sup>  
 False swearing . . . . . 746<sup>b</sup>  
 Fornication . . . . . 746<sup>b</sup>  
 Forswearing . . . . . 746<sup>b</sup>  
 Harlotry . . . . . 746<sup>b</sup>  
 of Heresy . . . . . 1377<sup>a</sup> (Jacobs)  
 Homicide . . . . . 746<sup>b</sup>  
 of Idolatry . . . . . 1447<sup>b</sup> (Cobern)  
 Incest . . . . . 747<sup>a</sup>  
 Infanticide . . . . . 747<sup>a</sup>  
 Irreverence . . . . . 747<sup>a</sup>  
 Kidnapping . . . . . 747<sup>a</sup>  
 of Lying . . . . . 1887<sup>a</sup> (W. Evans)  
 of Malice . . . . . 1972<sup>a</sup> (W. L. Walker)  
 of Manslaughter . . . . . 1983<sup>b</sup> (Hirsch)  
 of Murder . . . . . 2094<sup>a</sup> (Hirsch)  
 of Oath . . . . . 2172<sup>b</sup> (Levertoff)  
 Parents, crimes  
 against . . . . . 747<sup>b</sup>  
 Perjury  
 of Oath . . . . . 2172<sup>b</sup> (Levertoff)  
 Prophesying, false . . . . . 747<sup>b</sup>  
 Prostitution . . . . . 747<sup>b</sup>  
 Rape . . . . . 747<sup>b</sup>  
 Removing landmarks  
 of Landmark . . . . . 1826<sup>b</sup>  
 Reviling  
 of Punishments . . . . . 2504<sup>b</sup> (Hirsch)  
 Robbery . . . . . 747<sup>b</sup>  
 Sabbath-breaking . . . . . 747<sup>b</sup>  
 Seduction . . . . . 748<sup>a</sup>  
 of Seduce, Seducer . . . . . 2712<sup>a</sup> (Edwards)  
 of Slander . . . . . 2814<sup>b</sup> (Edwards)  
 Sodomy  
 of Unnatural Vice . . . . . 748<sup>a</sup>  
 Speaking evil . . . . . 748<sup>a</sup>  
 of Evil Speaking . . . . . 1043<sup>a</sup> (W. L. Walker)  
 of Slander . . . . . 2814<sup>b</sup> (Edwards)  
 Suicide . . . . . 748<sup>a</sup>  
 Theft . . . . . 748<sup>a</sup>  
 of Punishments . . . . . 2504<sup>b</sup> (Hirsch)  
 of Thief . . . . . 2972<sup>a</sup> (Easton)  
 Unchastity . . . . . 748<sup>a</sup>  
 of Lewdness . . . . . 1880<sup>b</sup> (Raffety)  
 of Marriage . . . . . 1996<sup>b</sup> (Eager)  
 of Uncleaness . . . . . 3035<sup>b</sup> (Williams)  
 Unnatural Vice . . . . . 748<sup>a</sup>

Crime—*continued*

- of Usury . . . . . 3041<sup>b</sup> (Pollard)  
 Witnessing, false . . . . . 748<sup>b</sup>  
 Whoredom . . . . . 748<sup>b</sup>  
 Crimson  
   of Colors . . . . . 674<sup>b</sup> (Patch)  
 Cripple . . . . . 748<sup>b</sup>  
   of Lamé . . . . . 1823<sup>b</sup> (Macalister)  
 Crisping Pins . . . . . 748<sup>b</sup>  
   of Pin . . . . . 2399<sup>a</sup> (N. Isaacs)  
 Crispus . . . . . 748<sup>b</sup>  
 Criticism  
   of Cain . . . . . 538<sup>b</sup> (Farr)  
   of High Place . . . . . 1390<sup>a</sup> (Easton)  
   of Priests and Levites . . . . . 2446<sup>b</sup> (Wiener)  
   of Sanctuary . . . . . 2686<sup>b</sup> (Wiener)  
 Criticism, Archaeology  
   and . . . . . 226<sup>a</sup> (Kyle)  
 Criticism of the Bible . . . . . 748<sup>b</sup> (Orr)  
   Higher . . . . . 751<sup>a</sup>  
   Lower or textual . . . . . 749<sup>b</sup>  
 Criticism (The Graf-Wellhausen Hypothesis) . . . . . 753<sup>b</sup> (Easton)  
 Crocodile  
   of Dragon . . . . . 873<sup>a</sup> (Day)  
   of Leviathan . . . . . 1868<sup>b</sup> (Day)  
 Crocodile, Land . . . . . 1826<sup>b</sup> (Day)  
   of Chameleon . . . . . 592<sup>a</sup> (Day)  
 Crook-backed . . . . . 760<sup>b</sup> (Macalister)  
 Crooked . . . . . 760<sup>b</sup>  
 Crooked Serpent  
   of Astronomy . . . . . 300<sup>b</sup> (Maunder)  
 Crop . . . . . 760<sup>b</sup>  
 Cross . . . . . 760<sup>b</sup> (Dosker)  
   of Blood and Water . . . . . 489<sup>a</sup> (Luering)  
   Crucifixion . . . . . 761<sup>b</sup>  
   Discovery of true cross . . . . . 761<sup>a</sup>  
   Forms of . . . . . 761<sup>a</sup>  
   Jesus' references to . . . . . 648<sup>b</sup> (Orr)  
   Symbolical uses of . . . . . 761<sup>a</sup>  
 Crossway . . . . . 762<sup>a</sup>  
 Crown . . . . . 762<sup>a</sup> (Raffety)  
   of Garland . . . . . 1175<sup>a</sup> (Doolan)  
   In Greek . . . . . 762<sup>b</sup>  
   In Hebrew . . . . . 762<sup>a</sup>  
   of Joshua's . . . . . 1748<sup>b</sup> (Roberts)  
   Of thorns . . . . . 763<sup>a</sup> (Dosker)  
   Use and significance . . . . . 762<sup>b</sup>  
 Crucifixion . . . . . 761<sup>b</sup> (Dosker)  
   of Punishments . . . . . 2504<sup>b</sup> (Hirsch)  
 Cruel, Cruelty . . . . . 763<sup>b</sup> (Kaiser)  
 Crumb . . . . . 764<sup>a</sup>  
 Cruse . . . . . 764<sup>a</sup> (Pollard)  
 Cry, Crying . . . . . 764<sup>b</sup> (W. L. Walker)  
 Crystal . . . . . 764<sup>b</sup> (Farr)  
   of Stones, Precious . . . . . 2856<sup>a</sup> (Fletcher)  
 Cub . . . . . 765<sup>a</sup>  
 Cubit . . . . . 765<sup>a</sup> (Porter)  
   of Measuring Reed . . . . . 2016<sup>b</sup>  
   of Reed, Measuring . . . . . 2545<sup>a</sup> (Orr)

Cubit—*continued*

- of Stature . . . . . 2850<sup>a</sup> (Easton)  
   of Temple . . . . . 2931<sup>a</sup>; 2935<sup>a</sup>; 2937<sup>a</sup> (Caldecott; Orr)  
   of Weights and Measures . . . . . 3079<sup>b</sup> (Porter)  
 Cuckow . . . . . 765<sup>a</sup> (Stratton-Porter)  
   of Sea-mew . . . . . 2707<sup>a</sup> (Stratton-Porter)  
 Cucumber . . . . . 765<sup>b</sup> (Masterman)  
   of Food . . . . . 1122<sup>a</sup> (Eager)  
 Cud  
   of Chew Cud . . . . . 605<sup>b</sup> (N. Isaacs)  
 Culture . . . . . 765<sup>b</sup>  
 Cumber . . . . . 765<sup>b</sup>  
 Cumi  
   of Talitha Cumi . . . . . 2904<sup>a</sup>  
 Cummin . . . . . 765<sup>b</sup> (Masterman); 1124<sup>a</sup> (Eager)  
 Cun . . . . . 765<sup>b</sup>  
 Cunning . . . . . 765<sup>b</sup> (W. L. Walker)  
 Cup . . . . . 766<sup>a</sup> (Jacobs)  
   of Blessing, Cup of . . . . . 487<sup>b</sup>  
   of Divination, Cups for . . . . . 860<sup>a</sup> (T. W. Davies)  
 Cupbearer . . . . . 766<sup>b</sup> (Downer)  
 Cupboard . . . . . 766<sup>b</sup>  
 Curdle . . . . . 766<sup>b</sup>  
 Cure . . . . . 766<sup>b</sup> (Macalister)  
 Curious . . . . . 767<sup>a</sup> (W. L. Walker)  
   of Astrology . . . . . 295<sup>b</sup> (Maunder)  
 Current Money . . . . . 2081<sup>a</sup> (Betteridge)  
 Curse . . . . . 767<sup>a</sup> (T. Lewis)  
   of Heredity . . . . . 1376<sup>a</sup> (Easton)  
   of Punishments . . . . . 2504<sup>b</sup> (Hirsch)  
 Curtain . . . . . 767<sup>b</sup>  
   of Tabernacle, Curtains  
     of . . . . . 2887<sup>b</sup> (Caldecott; Orr)  
 Cush (ethnological) . . . . . 767<sup>b</sup> (Pinches)  
   of Africa . . . . . 68<sup>a</sup> (Pinches)  
   of Eden . . . . . 897<sup>b</sup> (Wright)  
   of Ethiopia . . . . . 1031<sup>a</sup> (Cobern)  
   of Table of Nations . . . . . 2898<sup>b</sup> (Pinches)  
 Cush (person) . . . . . 768<sup>b</sup>  
   of Cushi . . . . . 768<sup>b</sup> (Boyd)  
 Cushman . . . . . 768<sup>b</sup> (Boyd)  
 Cushman-rishathaim . . . . . 768<sup>b</sup> (Baur)  
 Cushi . . . . . 768<sup>b</sup> (Boyd)  
 Cushion . . . . . 769<sup>a</sup> (Downer)  
 Cushite . . . . . 769<sup>a</sup> (Boyd)  
 Cushite Woman . . . . . 769<sup>a</sup> (Boyd)  
 Custody . . . . . 769<sup>a</sup>  
 Custom . . . . . 769<sup>a</sup> (Betteridge); 769<sup>b</sup> (Farr)  
 Cut, Cutting . . . . . 769<sup>b</sup> (W. L. Walker)  
   of Concision . . . . . 696<sup>b</sup>  
   of Cuttings in the Flesh . . . . . 770<sup>a</sup> (Eager)  
 Cut Asunder . . . . . 316<sup>b</sup>  
 Cuth . . . . . 770<sup>a</sup> (Pinches)  
 Cutha . . . . . 770<sup>a</sup>  
 Cuthah  
   of Cuth . . . . . 770<sup>a</sup> (Pinches)

- Cuthean, Cuthite  
 of Cuth . . . . . 770<sup>a</sup> (Pinches)  
 of Samaritans . . . . . 2673<sup>b</sup> (Ewing)
- Cutting Asunder  
 of Asunder . . . . . 316<sup>a</sup> (S. F. Hunter)  
 of Punishments . . . . . 2504<sup>b</sup> (Hirsch)
- Cutting Off  
 of Punishments . . . . . 2504<sup>b</sup> (Hirsch)
- Cuttings in the Flesh . . . . . 770<sup>a</sup> (Eager)  
 of Mark (noun) . . . . . 1986<sup>a</sup> (Pratt)
- Cyamon . . . . . 770<sup>b</sup>  
 of Jokneam . . . . . 1727<sup>a</sup> (Ewing)
- Cymbal  
 of Music . . . . . 2101<sup>a</sup> (Millar)
- Cypress . . . . . 509<sup>b</sup> (Masterman)  
 of Holm Tree . . . . . 1405<sup>a</sup> (Masterman)
- Cyprians . . . . . 770<sup>b</sup> (Fortune)  
 of Asiarch . . . . . 282<sup>a</sup> (M. O. Evans)
- Cyprus . . . . . 771<sup>a</sup> (Tod)  
 Church in . . . . . 772<sup>a</sup>  
 Early history . . . . . 771<sup>a</sup>  
 Geography . . . . . 771<sup>a</sup>  
 And the Greeks . . . . . 771<sup>b</sup>  
 And the Jews . . . . . 772<sup>a</sup>  
 of Kittim . . . . . 1814<sup>b</sup> (Pinches)  
 Later history . . . . . 772<sup>b</sup>  
 Name . . . . . 771<sup>a</sup>  
 of Paphos . . . . . 2237<sup>b</sup> (Tod)  
 Products . . . . . 771<sup>a</sup>  
 And Rome . . . . . 771<sup>b</sup>
- Cyrama (Kirama) . . . . . 1811<sup>a</sup>
- Cyréne . . . . . 772<sup>b</sup> (Kyle)
- Cyrenian . . . . . 773<sup>b</sup>  
 of Cyréne . . . . . 772<sup>b</sup> (Kyle)  
 of Lucius . . . . . 1935<sup>a</sup> (S. F. Hunter)  
 of Simon . . . . . 2795<sup>b</sup> (S. F. Hunter)
- Cyrenius (Quirinius) . . . . . 2515<sup>b</sup>
- Cyria . . . . . 773<sup>b</sup>  
 of Lady . . . . . 1821<sup>b</sup>
- Cyrus . . . . . 773<sup>b</sup> (Pinches); 368<sup>a</sup> (Clay)  
 Babylonian Chronicle . . . . . 774<sup>b</sup>  
 Babylonian records of  
 reign . . . . . 774<sup>b</sup>  
 His country . . . . . 773<sup>b</sup>  
 Cylinder of . . . . . 775<sup>a</sup>  
 Genealogy of . . . . . 773<sup>b</sup>  
 of Israel, History of . . . . . 1526<sup>a</sup> (Orelli)  
 And the Jews . . . . . 776<sup>b</sup>  
 Massagetæ . . . . . 775<sup>b</sup>  
 His origin . . . . . 773<sup>b</sup>  
 In Persia . . . . . 776<sup>b</sup>  
 of Persians . . . . . 2336<sup>a</sup> (Tisdall)  
 Reputation of . . . . . 776<sup>a</sup>  
 Sacæ, Berbices . . . . . 775<sup>b</sup>
- Dabareh (Daberath) . . . . . 776<sup>a</sup>
- Dabbesheth . . . . . 776<sup>a</sup>
- Daberath . . . . . 776<sup>a</sup>
- Dabria . . . . . 776<sup>a</sup>
- Dacubi . . . . . 776<sup>a</sup>  
 of Akkub . . . . . 89<sup>a</sup>  
 of Dakubi . . . . . 777<sup>a</sup>
- Dadda  
 of Hadad . . . . . 1313<sup>b</sup> (Hovey)
- Daddeus . . . . . 776<sup>a</sup>
- Dadu  
 of Hadad . . . . . 1313<sup>b</sup> (Hovey)
- Dagger  
 of Armor . . . . . 251<sup>a</sup> (Nicol)
- Dagon . . . . . 776<sup>b</sup> (Margolis)  
 of Gods . . . . . 1271<sup>a</sup> (Reeve)
- Daily . . . . . 777<sup>a</sup> (W. Evans)
- Daily Offering or Sacrifice  
 of Sacrifice . . . . . 2651<sup>a</sup> (Williams)
- Dainties, Dainty Meats . . . . . 777<sup>a</sup> (Eager)  
 of Delicate . . . . . 820<sup>a</sup> (W. W. Davies)  
 of Food . . . . . 1121<sup>b</sup> (Eager)
- Daisan . . . . . 777<sup>a</sup>
- Dakubi . . . . . 777<sup>a</sup>
- Dalaiah (Delaiah) . . . . . 819<sup>b</sup>
- Dalan . . . . . 777<sup>b</sup>
- Dale, King's . . . . . 777<sup>b</sup> (Masterman)  
 of King's Garden . . . . . 1808<sup>a</sup> (Masterman)  
 of Vale, Valley . . . . . 3045<sup>a</sup> (Day)
- Daleth . . . . . 777<sup>b</sup>  
 of Alphabet . . . . . 103<sup>b</sup> (Richardson)
- Dally . . . . . 777<sup>b</sup>
- Dalmanutha  
 of Magadan . . . . . 1961<sup>b</sup> (Ewing)
- Dalmatia . . . . . 777<sup>b</sup> (Tod)  
 of Illyricum . . . . . 1449<sup>b</sup> (Tod)
- Dalphon . . . . . 778<sup>a</sup>
- Dam . . . . . 778<sup>a</sup>
- Damage . . . . . 778<sup>a</sup> (Breslich)
- Damaris . . . . . 778<sup>a</sup>
- Damascenes . . . . . 778<sup>a</sup>
- Damascus . . . . . 778<sup>a</sup> (C. H. Thomson)  
 Description of city . . . . . 778<sup>b</sup>  
 History . . . . . 779<sup>a</sup>  
 Aramaean kingdom . . . . . 779<sup>b</sup>  
 Early period . . . . . 779<sup>a</sup>  
 Middle period . . . . . 780<sup>a</sup>  
 Location and natural  
 features . . . . . 778<sup>b</sup>  
 Name . . . . . 778<sup>a</sup>
- Dammesek Eliezer  
 of Eliezer . . . . . 929<sup>b</sup> (S. F. Hunter)
- Damn, Damnation,  
 Damnable . . . . . 780<sup>b</sup> (Rees)  
 of Eschatology (NT) . . . . . 979<sup>b</sup> (Vos)  
 of Judgment . . . . . 1777<sup>a</sup> (Jacobs)
- Damsel . . . . . 781<sup>a</sup>
- Dan (city) . . . . . 782<sup>a</sup> (Ewing)  
 of Laish . . . . . 1821<sup>b</sup>  
 of Vedan . . . . . 3046<sup>b</sup> (Fulton)
- Dan (person and tribe) . . . . . 781<sup>a</sup> (Ewing)  
 Danite raid . . . . . 781<sup>b</sup>  
 of Micah . . . . . 2045<sup>b</sup> (Lees)  
 Name . . . . . 781<sup>b</sup>  
 Territory occupied by  
 tribe . . . . . 781<sup>b</sup>  
 Tribe . . . . . 781<sup>b</sup>  
 of Rearward . . . . . 2534<sup>b</sup>

- Dancing  
of Games . . . . . 1169<sup>b</sup> (Smith)
- Dandle . . . . . 782<sup>a</sup>
- Danger . . . . . 782<sup>a</sup> (Breslich)
- Daniel . . . . . 782<sup>b</sup> (R. D. Wilson)  
Bel and the Dragon . . . . . 428<sup>a</sup>  
Early life . . . . . 782<sup>b</sup>  
Interpreter of dreams . . . . . 782<sup>b</sup>  
Interpreter of signs . . . . . 783<sup>a</sup>  
Official of kings . . . . . 783<sup>a</sup>  
Seer of visions . . . . . 783<sup>a</sup>  
of Seventy Weeks . . . . . 2744<sup>a</sup> (Orr)  
of Susanna, the History of . . . . . 2872<sup>b</sup> (T. W. Davies)
- Daniel, Book of . . . . . 783<sup>b</sup> (R. D. Wilson)  
Apocryphal additions . . . . . 787<sup>a</sup>  
Canonicity . . . . . 783<sup>b</sup>  
Divisions . . . . . 783<sup>b</sup>  
Doctrines . . . . . 786<sup>b</sup>  
Angels . . . . . 787<sup>a</sup>  
Resurrection . . . . . 787<sup>a</sup>
- Genuineness . . . . . 784<sup>b</sup>  
As to historical misstatements . . . . . 785<sup>b</sup>  
As to language . . . . . 785<sup>b</sup>  
As to miracles . . . . . 785<sup>a</sup>  
As to predictions . . . . . 784<sup>b</sup>  
As to text . . . . . 785<sup>a</sup>
- Interpretation . . . . . 786<sup>b</sup>  
of Kingdom of God . . . . . 1805<sup>b</sup> (Stalker)
- Languages . . . . . 784<sup>a</sup>  
Purpose . . . . . 784<sup>a</sup>  
Unity . . . . . 784<sup>b</sup>
- Danites . . . . . 787<sup>b</sup>
- Dan-jaan . . . . . 787<sup>b</sup>
- Dannah . . . . . 787<sup>b</sup>
- Daphne . . . . . 787<sup>b</sup> (Ewing)
- Dara  
of Darda . . . . . 788<sup>a</sup>
- Darda . . . . . 788<sup>a</sup>
- Dare . . . . . 788<sup>a</sup>
- Daric . . . . . 788<sup>a</sup>  
of Siglos . . . . . 2789<sup>a</sup>
- Darius . . . . . 788<sup>a</sup> (R. D. Wilson)  
Darius Hystaspes . . . . . 788<sup>b</sup>  
Darius the Mede . . . . . 788<sup>a</sup>  
Darius Nothus . . . . . 788<sup>b</sup>  
of Persians . . . . . 2336<sup>b</sup> (Tisdall)
- Dark, Darkness . . . . . 789<sup>a</sup> (Joy)  
of Eclipse . . . . . 303<sup>b</sup>; 310<sup>a</sup> (Maunder)  
of Plagues . . . . . 2402<sup>b</sup> (Macalister)
- Darkly . . . . . 789<sup>a</sup>
- Darkon . . . . . 789<sup>a</sup>  
of Lozon . . . . . 1934<sup>b</sup>
- Dark Sayings . . . . . 789<sup>a</sup> (Margolis)
- Darling . . . . . 789<sup>b</sup>
- Dart . . . . . 789<sup>b</sup>  
Armor . . . . . 251<sup>a</sup> (Nicol)
- Dart-snake  
of Arrowsnake . . . . . 260<sup>a</sup>
- Darwinism . . . . . 148<sup>a</sup> (Marais)
- Dash . . . . . 789<sup>a</sup> (Breslich)
- Dates . . . . . 790<sup>a</sup>  
of Food . . . . . 1123<sup>a</sup> (Eager)  
of Palm Tree . . . . . 2235<sup>a</sup> (Masterman)
- Dathan . . . . . 790<sup>a</sup> (Beecher)  
And Abiram  
of Korah . . . . . 1817<sup>a</sup> (Beecher)
- Dathema . . . . . 790<sup>a</sup>
- Daub . . . . . 790<sup>a</sup>
- Daughter . . . . . 790<sup>a</sup> (Pollard)  
of Girl . . . . . 1232<sup>a</sup>
- Daughter-in-Law  
of Relationships,  
Family . . . . . 2554<sup>a</sup> (E. D. and N. Isaacs)
- David . . . . . 790<sup>b</sup> (Weir); 8<sup>a</sup> (Beecher);  
255<sup>b</sup> (Nicol)  
of Absalom . . . . . 23<sup>a</sup> (W. W. Davies)  
Bethlehemite . . . . . 450<sup>a</sup> (Masterman)  
Buildings of . . . . . 1614<sup>a</sup> (Masterman)  
of Cave of Adullam . . . . . 62<sup>b</sup> (Beecher)  
Domestic life . . . . . 794<sup>b</sup>  
Domestic trouble . . . . . 794<sup>b</sup>  
Wives and children . . . . . 794<sup>b</sup>
- Early years . . . . . 790<sup>b</sup>
- In exile . . . . . 793<sup>a</sup>  
Alliance with Philistines . . . . . 793<sup>a</sup>  
As an outlaw . . . . . 793<sup>a</sup>
- Flight of . . . . . 23<sup>b</sup>
- Friendship of Jonathan . . . . . 1731<sup>b</sup> (Weir)
- of Judah, Kingdom of . . . . . 1759<sup>b</sup> (Weir)
- At Keilah . . . . . 1791<sup>a</sup> (Masterman)
- Kingship . . . . . 793<sup>b</sup>  
Civil war . . . . . 793<sup>b</sup>  
Foreign conquests . . . . . 793<sup>b</sup>  
Removal of ark . . . . . 794<sup>a</sup>
- Lament of . . . . . 24<sup>a</sup>
- of Mephibosheth . . . . . 2033<sup>b</sup> (Wallace)
- Name and genealogy . . . . . 790<sup>b</sup>
- of Nathan . . . . . 2120<sup>a</sup> (Roberts)
- Officials . . . . . 794<sup>b</sup>
- of Palestine . . . . . 2215<sup>b</sup> (Conder)
- Personal character . . . . . 795<sup>a</sup>  
Authorship of  
Psalms . . . . . 795<sup>b</sup>  
Complexity of character . . . . . 795<sup>b</sup>  
Courage . . . . . 795<sup>b</sup>  
Estimate of Chronicles . . . . . 795<sup>a</sup>  
Family relations . . . . . 796<sup>b</sup>  
Friendships . . . . . 796<sup>b</sup>  
Nobility . . . . . 796<sup>a</sup>  
Strategy . . . . . 796<sup>a</sup>
- of Philistines . . . . . 2379<sup>a</sup> (Conder)
- of Psalms, Book of . . . . . 2489<sup>a</sup> (Sampey)
- of Samuel, Books of . . . . . 2679<sup>b</sup> (Geden)
- of Saul . . . . . 2698<sup>b</sup> (Weir)
- Service of Saul . . . . . 791<sup>b</sup>  
First exploits . . . . . 792<sup>a</sup>  
Flight of David . . . . . 792<sup>b</sup>

- David—*continued*  
 Service of Saul—*continued*  
 Jealousy of Saul . . . 792<sup>a</sup>  
 Jonathan and David . 792<sup>b</sup>  
 of Temple . . . . . 2930<sup>b</sup> (Caldecott; Orr)
- David, City of  
 of Zion . . . . . 3150<sup>b</sup> (Masterman)
- David, Root of . . . . . 797<sup>b</sup>  
 of Root of Jesse . . . . . 2623<sup>b</sup>
- David, Tower of  
 of Jerusalem . . . . . 1607<sup>b</sup> (Masterman)
- Dawn, Dawning . . . . . 797<sup>b</sup> (Porter)
- Day of Atonement  
 of Atonement, Day of . 324<sup>b</sup> (Möller)
- Day before the Sabbath . 798<sup>b</sup> (Hirsch)
- Day, Break of  
 of Break of Day . . . . . 517<sup>b</sup>
- Day of Christ  
 of Lord's Day . . . . . 1919<sup>a</sup> (Easton)
- Day (figurative) . . . . . 798<sup>a</sup> (Dosker)  
 of Third . . . . . 2973<sup>a</sup>
- Day (general) . . . . . 797<sup>b</sup> (Gerberding)  
 of Afternoon . . . . . 68<sup>b</sup> (Wolf)  
 of Time . . . . . 2982<sup>a</sup> (Porter)
- Day of Jehovah  
 of Lord's Day . . . . . 1919<sup>a</sup> (Easton)
- Day, Joshua's Long  
 of Beth-horon, Battle  
 of . . . . . 446<sup>b</sup> (Maunder)
- Day of Judgment  
 of Judgment, Last . . . 1777<sup>b</sup> (Easton)
- Day, Last . . . . . 799<sup>a</sup> (Orr)  
 of Eschatology of OT . 972<sup>a</sup> (Orr)  
 of Last Time . . . . . 1840<sup>a</sup> (Vos)
- Day of the Lord (Jehovah)  
 of . . . . . 799<sup>a</sup> (Dosker)  
 of Eschatology of NT . 979<sup>b</sup> (Vos)  
 of Eschatology of OT . 972<sup>a</sup> (Orr)  
 of Judgment, Last . . . 1777<sup>b</sup> (Easton)  
 of Parousia . . . . . 2249<sup>a</sup> (Easton)
- Day, Lord's  
 of Lord's Day . . . . . 1919<sup>a</sup> (Easton)
- Day and Night . . . . . 798<sup>a</sup> (Wolf)  
 of Night . . . . . 2143<sup>b</sup> (Dosker)  
 of Noon, Noonday . . . 2155<sup>a</sup>
- Day's Journey . . . . . 799<sup>b</sup> (Stratton-Porter)
- Days, Last  
 of Eschatology of OT . 972<sup>a</sup> (Orr)  
 of Last Time . . . . . 1840<sup>a</sup> (Vos)
- Daysman . . . . . 799<sup>b</sup> (A. W. Evans)
- Dayspring . . . . . 799<sup>b</sup> (Trevor)
- Day-star . . . . . 800<sup>a</sup> (Maunder)  
 of Astronomy . . . . . 300<sup>b</sup> (Maunder)
- Day, That (The)  
 of Day of the Lord . . 799<sup>a</sup> (Dosker)
- Deacon, Deaconess . . . 400<sup>a</sup> (Heidel)  
 of Bishop . . . . . 478<sup>b</sup> (Dosker)  
 of Church . . . . . 650<sup>b</sup> (Lambert)  
 of Church Government . 653<sup>b</sup> (Forrester)  
 of Ministry . . . . . 2059<sup>b</sup> (T. M. Lindsay)  
 of Woman . . . . . 3103<sup>b</sup> (Pratt)
- Dead . . . . . 800<sup>b</sup> (Macalister)
- Dead, Baptism for the . . 399<sup>a</sup> (Rees)
- Dead Body  
 of Corpse . . . . . 722<sup>b</sup> (Luering)
- Deadly . . . . . 801<sup>a</sup> (Luering)
- Dead Sea, The . . . . . 801<sup>a</sup> (Wright)  
 Climate . . . . . 807<sup>a</sup>  
 Constitution of water . 806<sup>b</sup>  
 Former area . . . . . 801<sup>b</sup>  
 of Gomorrah . . . . . 1277<sup>a</sup> (Wright)  
 History . . . . . 810<sup>a</sup>  
 of Jordan . . . . . 1732<sup>b</sup> (Wright)  
 of Jordan Valley . . . . 1735<sup>a</sup> (Wright)
- Level in early historic  
 times . . . . . 802<sup>b</sup>  
 Geological evidence . 803<sup>a</sup>  
 Soundings in 1849 . . 804<sup>b</sup>
- Miscellaneous . . . . . 807<sup>b</sup>  
 Ain Jidi . . . . . 807<sup>b</sup>  
 Fortress of Masada . 808<sup>a</sup>  
 Jebel Usdum . . . . . 808<sup>b</sup>  
 Plain of the Jordan . 807<sup>b</sup>  
 Vale of Siddim . . . . . 809<sup>b</sup>
- of Palestine, Recent  
 Exploration . . . . . 2223<sup>b</sup> (Cobern)  
 Present area . . . . . 801<sup>b</sup>  
 Roads . . . . . 807<sup>b</sup>  
 of Salt . . . . . 2664<sup>a</sup> (Patch)  
 of Siddim . . . . . 2784<sup>a</sup> (Wright)  
 of Sodom . . . . . 2821<sup>b</sup> (Wright)  
 of Zoar . . . . . 3154<sup>a</sup> (Wright)
- Dead, State of the  
 of Hades . . . . . 1314<sup>a</sup> (Vos)
- Deaf . . . . . 811<sup>a</sup> (Macalister)  
 of Dumb . . . . . 882<sup>a</sup> (Macalister)
- Deal . . . . . 811<sup>a</sup> (Breslich)
- Dear, Dearly . . . . . 811<sup>a</sup> (Jacobs)
- Dearth  
 of Famine . . . . . 1097<sup>a</sup> (W. L. Walker)
- Death . . . . . 811<sup>a</sup> (Macalister; Bavinck)  
 of Heredity . . . . . 1376<sup>a</sup> (Easton)  
 of Immortality . . . . 1458<sup>b</sup> (Orr)
- Physiological and figurative views . . . . 811<sup>a</sup> (Macalister)
- of Psychology . . . . . 2498<sup>b</sup> (Marais)
- of Sheol . . . . . 2761<sup>a</sup> (Orr)
- Theological view . . . . 811<sup>b</sup> (Bavinck)  
 Conception of sin  
 and death . . . . . 811<sup>b</sup>  
 Israelitish dread of  
 death . . . . . 812<sup>a</sup>  
 Non-Christian death . 812<sup>b</sup>  
 Spiritual significance . . . . 812<sup>b</sup>
- Death, Body of . . . . . 493<sup>a</sup> (Dosker)
- Death, Second . . . . . 813<sup>a</sup>  
 of Eschatology of NT . 979<sup>b</sup> (Vos)
- Debate . . . . . 813<sup>a</sup>  
 of Makebates . . . . . 1968<sup>b</sup>
- Debir (person) . . . . . 813<sup>b</sup>
- Debir (place) . . . . . 813<sup>b</sup> (Masterman)  
 of Negeb . . . . . 2130<sup>a</sup> (Masterman)

- Deborah . . . . . 813<sup>b</sup> (Margolis)  
 cf Sisera . . . . . 2812<sup>b</sup> (Schenk)
- Deborah, Song of  
 cf Jael . . . . . 1558<sup>a</sup> (Schenk)
- Debt, Debtor . . . . . 814<sup>a</sup> (W. Evans)  
 Figurative . . . . . 814<sup>b</sup>  
 NT teachings . . . . . 814<sup>b</sup>  
 OT practice . . . . . 814<sup>b</sup>  
 cf Surety . . . . . 2872<sup>a</sup> (Reeve)
- Decalogue  
 cf Ten Command-  
 ments . . . . . 2944<sup>b</sup> (Sampey)
- Decapolis . . . . . 815<sup>a</sup> (Ewing)  
 cf Gadara . . . . . 1152<sup>b</sup> (Ewing)
- Decay . . . . . 815<sup>a</sup> (Farr)
- Decease in NT . . . . . 815<sup>b</sup>
- Decease in OT and Apoc. 815<sup>a</sup> (Luering)  
 cf Corpse . . . . . 722<sup>b</sup> (Luering)  
 cf Death . . . . . 812<sup>a</sup> (Bavinck)  
 cf Hades . . . . . 1314<sup>b</sup> (Vos)  
 cf Sheol . . . . . 2761<sup>a</sup> (Orr)
- Deceit . . . . . 815<sup>b</sup>
- Deceivableness, Deceive . 816<sup>a</sup> (Farr)
- Decently . . . . . 816<sup>a</sup>
- Decision . . . . . 816<sup>a</sup> (Fortune)  
 cf Augury . . . . . 331<sup>a</sup> (T. W. Davies)
- Decision, Valley of  
 cf Jehoshaphat, Valley  
 of . . . . . 1583<sup>a</sup> (Masterman)
- Declaration, Declare . . . 816<sup>b</sup>
- Decline . . . . . 816<sup>b</sup>
- Dedan, Dedanites . . . . . 816<sup>b</sup> (Orr)
- Dedicate . . . . . 816<sup>b</sup>  
 cf Consecration . . . . . 703<sup>b</sup> (Rees)  
 cf Sanctification . . . . . 2681<sup>b</sup> (Rall)
- Dedication, Feast of . . . 816<sup>b</sup> (Orr)
- Deed . . . . . 817<sup>a</sup> (Edwards)  
 cf Accord . . . . . 33<sup>b</sup> (M. O. Evans)
- Deep . . . . . 817<sup>a</sup>  
 cf Abyss . . . . . 26<sup>b</sup> (T. Lewis)  
 cf Astronomy . . . . . 300<sup>b</sup> (Maunder)
- Deep Sleep . . . . . 2817<sup>b</sup> (Easton)
- Deer . . . . . 817<sup>a</sup> (Day)  
 cf Gazelle . . . . . 1179<sup>a</sup> (Day)  
 cf Goat . . . . . 1249<sup>a</sup> (Day)  
 cf Roe, Roebuck . . . . . 2597<sup>a</sup> (Day)
- Defame . . . . . 818<sup>a</sup>
- Defect . . . . . 818<sup>a</sup> (Fortune)
- Defence  
 cf Courts, Judicial . . . . 725<sup>b</sup> (Hirsch)
- Defenced  
 cf Fortification . . . . . 1136<sup>b</sup> (Nicol)
- Defer . . . . . 818<sup>a</sup>
- Defile, Defilement . . . . 818<sup>a</sup> (Crannell)  
 Defilement in NT . . . . . 818<sup>b</sup>  
 Defilement in OT . . . . . 818<sup>b</sup>  
 cf Totemism . . . . . 3000<sup>a</sup> (M. O. Evans)
- Defy . . . . . 819<sup>a</sup>
- Degenerate . . . . . 819<sup>a</sup>
- Degree . . . . . 819<sup>a</sup> (Edwards)
- Degrees, Songs of . . . . . 819<sup>b</sup> (Sampey); 842<sup>b</sup>  
 (Maunder)
- Dehates . . . . . 819<sup>b</sup>
- Dehort . . . . . 819<sup>b</sup>
- Dekar . . . . . 819<sup>b</sup>  
 cf Ben-deker . . . . . 434<sup>b</sup>
- Delalah . . . . . 819<sup>b</sup>
- Delay . . . . . 820<sup>a</sup> (Breslich)
- Delectable . . . . . 820<sup>a</sup>
- Delicacy . . . . . 820<sup>a</sup>
- Delicate . . . . . 820<sup>a</sup> (W. W. Davies)
- Deliciously . . . . . 820<sup>a</sup>
- Delight . . . . . 820<sup>a</sup> (W. L. Walker)
- Delightful . . . . . 820<sup>b</sup>
- Delilah . . . . . 820<sup>b</sup> (Beecher)  
 cf Samson . . . . . 2675<sup>a</sup> (Robinson)
- Deliver . . . . . 820<sup>b</sup> (W. L. Walker)
- Delos . . . . . 821<sup>a</sup> (Harry)
- Deluge of Noah, The . . . . 821<sup>b</sup> (Wright)  
 American Indian tra-  
 ditions . . . . . 822<sup>b</sup>  
 cf Ark of Noah . . . . . 246<sup>a</sup> (Wright)  
 In Babylonian liter-  
 ature . . . . . 374<sup>a</sup> (Rogers)  
 Babylonian traditions 823<sup>a</sup>  
 Biblical account . . . . . 821<sup>b</sup>  
 Chinese account . . . . . 822<sup>b</sup>  
 Cuneiform tablets . . . . . 823<sup>b</sup>  
 Druid legend . . . . . 822<sup>b</sup>  
 Egyptian tradition . . . . . 822<sup>a</sup>  
 cf Flood . . . . . 1120<sup>a</sup> (Day)  
 cf Gopher Wood . . . . . 1279<sup>b</sup> (Masterman)  
 Greek tradition . . . . . 822<sup>b</sup>  
 Indian tradition . . . . . 822<sup>a</sup>  
 cf Noah . . . . . 2153<sup>a</sup> (Wright)  
 "Noah's Log Book" . . . . . 822<sup>a</sup>  
 Was flood universal? . . . . 824<sup>b</sup>  
 Extent of human  
 race . . . . . 824<sup>b</sup>  
 Geological evidence 825<sup>b</sup>  
 Glacial epoch . . . . . 824<sup>b</sup>
- Delusion . . . . . 826<sup>a</sup> (Edwards)
- Demand . . . . . 826<sup>a</sup>
- Demas . . . . . 826<sup>a</sup>  
 cf Apostasy . . . . . 202<sup>a</sup> (Pratt)
- Demetrius . . . . . 826<sup>a</sup> (Kinsella); 827<sup>b</sup>  
 (Banks)
- Demetrius I . . . . . 826<sup>a</sup>  
 cf Antiochus Epiph-  
 anes . . . . . 159<sup>b</sup> (Harry)  
 cf Bacchides . . . . . 375<sup>b</sup> (Breslich)  
 cf Maccabaeus . . . . . 1946<sup>a</sup> (Hutchison)
- Demetrius II . . . . . 826<sup>b</sup>
- Demetrius III . . . . . 827<sup>a</sup>  
 cf John, Epistles of . . . . . 1718<sup>b</sup> (Law)  
 cf Tryphon . . . . . 3027<sup>a</sup> (Angus)
- Demon, Demoniac, De-  
 monology . . . . . 827<sup>b</sup> (Sweet)  
 cf Accommodation . . . . . 33<sup>a</sup> (Sweet)
- Definition . . . . . 827<sup>b</sup>  
 cf Jesus Christ . . . . . 1640<sup>a</sup> (Orr)  
 cf Magic, Magician . . . . . 1964<sup>b</sup> (T. W. Davies)  
 cf Mary Magdalene . . . . . 2003<sup>b</sup> (Sweet)  
 NT demonology . . . . . 828<sup>a</sup>

- Demon, Demoniac, Demonology—*continued*  
 of Night-monster . . . 2143<sup>b</sup> (Sweet)  
 Origin of Biblical  
 demonology . . . . . 827<sup>b</sup>  
 Animism . . . . . 827<sup>b</sup>  
 Babylonian ideas . . . 829<sup>a</sup>  
 Evolutionary theory 827<sup>a</sup>  
 of Azazel . . . . . 342<sup>b</sup> (Möller)  
 of Communion  
 with Demons . . 689<sup>b</sup> (Sweet)  
 Heathen deities . . . 828<sup>a</sup>  
 Polytheism . . . . . 828<sup>a</sup>  
 Demophon . . . . . 829<sup>b</sup>  
 Den . . . . . 829<sup>b</sup> (Day)  
 of Cave . . . . . 585<sup>a</sup> (Day)  
 Denarius . . . . . 830<sup>a</sup> (Porter)  
 of Money . . . . . 2076<sup>a</sup> (Porter)  
 Denounce . . . . . 830<sup>a</sup>  
 Deny . . . . . 830<sup>a</sup> (Gray)  
 of Peter, Simon . . . . 2348<sup>b</sup> (Gray)  
 Depart Asunder . . . . . 316<sup>b</sup> (S. F. Hunter)  
 Deposit . . . . . 830<sup>a</sup> (Jacobs)  
 Depth . . . . . 314<sup>b</sup>  
 of Abyss . . . . . 26<sup>b</sup> (T. Lewis)  
 Deputy . . . . . 830<sup>b</sup> (Heidel)  
 of Government . . . . . 1287<sup>a</sup> (Heidel)  
 Derbe . . . . . 830<sup>b</sup> (Calder)  
 of Lycaonia . . . . . 1942<sup>b</sup> (Calder)  
 Derision . . . . . 831<sup>b</sup>  
 Descend . . . . . 831<sup>b</sup> (Jacobs)  
 Descent of Jesus  
 of Apocryphal Gos-  
 pels . . . . . 195<sup>a</sup> (Hutchison)  
 Describe . . . . . 831<sup>b</sup> (W. W. Davies)  
 Descry . . . . . 831<sup>b</sup>  
 Desert . . . . . 831<sup>b</sup> (Day)  
 of Natural Features . . 2122<sup>a</sup> (Day)  
 Desire . . . . . 832<sup>b</sup> (Breslich)  
 Desire of All Nations . . 832<sup>b</sup> (Gray)  
 Desolate . . . . . 833<sup>a</sup> (Edwards)  
 Desolation, Abomination  
 of . . . . . 16<sup>a</sup> (Hirsch)  
 Despair . . . . . 833<sup>b</sup> (Edwards)  
 Despite, Despiteful . . . 833<sup>b</sup> (Edwards)  
 Dessau . . . . . 833<sup>b</sup>  
 Destiny (Meni) . . . . . 833<sup>b</sup>  
 of Astrology . . . . . 295<sup>b</sup> (Maunder)  
 of Meni . . . . . 2033<sup>a</sup>  
 Destroyer . . . . . 833<sup>b</sup> (Edwards)  
 Destruction . . . . . 834<sup>a</sup>  
 of Abaddon . . . . . 2<sup>b</sup> (Beecher)  
 Destruction, City of (He-  
 liopolis or City of the  
 Sun)  
 of Astronomy . . . . . 301<sup>b</sup> (Maunder)  
 of Ir-ha-heres . . . . . 1491<sup>a</sup> (Kyle)  
 of On . . . . . 2193<sup>a</sup> (Kyle)  
 Determinate . . . . . 834<sup>a</sup> (Edwards)  
 Determine . . . . . 834<sup>a</sup> (Fortune)  
 Detestable Things . . . . 834<sup>a</sup> (Margolis)  
 of Abomination . . . . . 6<sup>b</sup> (Breslich); 15<sup>b</sup> (Eager)  
 Deuel . . . . . 834<sup>b</sup>  
 Deutero-canonical Books 834<sup>b</sup> (Fortune)  
 of Apocrypha . . . . . 178<sup>b</sup> (T. W. Davies)  
 of Canon of OT . . . . . 554<sup>a</sup> (Robinson)  
 NT Books . . . . . 835<sup>a</sup>  
 OT Books . . . . . 834<sup>b</sup>  
 Deuteronomy . . . . . 835<sup>b</sup> (Robinson)  
 Analysis . . . . . 835<sup>b</sup>  
 Authorship . . . . . 836<sup>b</sup>  
 History appropri-  
 ate to Moses'  
 time . . . . . 836<sup>b</sup>  
 Language assumes  
 Moses' author-  
 ship . . . . . 837<sup>a</sup>  
 Military law book . . 837<sup>a</sup>  
 Critical theory . . . . . 838<sup>b</sup>  
 Double allusions . . . . 837<sup>a</sup>  
 of Government . . . . . 1288<sup>b</sup> (Heidel)  
 of High Place . . . . . 1390<sup>a</sup> (Easton)  
 of Hilkiah . . . . . 1392<sup>a</sup> (Wallace)  
 Influence on Israel's  
 history . . . . . 837<sup>b</sup>  
 of Josiah . . . . . 1753<sup>a</sup> (Genung)  
 Late date of . . . . . 1752<sup>b</sup> (Genung)  
 of Law in OT . . . . . 1854<sup>b</sup> (Rule)  
 of Moses . . . . . 2088<sup>b</sup> (Kyle); 2090<sup>a</sup>  
 (Kyle)  
 Name . . . . . 835<sup>b</sup>  
 Object of book . . . . . 835<sup>b</sup>  
 of Palestine . . . . . 2211<sup>b</sup> (Conder)  
 Ruling ideas . . . . . 836<sup>a</sup>  
 Relations of God and  
 Israel . . . . . 836<sup>a</sup>  
 Unity . . . . . 836<sup>b</sup>  
 Device . . . . . 840<sup>a</sup> (Edwards)  
 Devil  
 of Demon . . . . . 827<sup>b</sup> (Sweet)  
 of Satan . . . . . 2693<sup>b</sup> (Sweet)  
 Devoted Things  
 of Curse . . . . . 767<sup>a</sup> (T. Lewis)  
 of Dedicate . . . . . 816<sup>b</sup>  
 Devotion, Devotions . . . 840<sup>a</sup>  
 Devout . . . . . 840<sup>a</sup> (M. O. Evans)  
 of Rome . . . . . 2622<sup>a</sup> (Allen)  
 Dew . . . . . 840<sup>b</sup> (Joy)  
 Diadem . . . . . 841<sup>a</sup> (Raffety)  
 of Crown . . . . . 762<sup>a</sup> (Raffety)  
 Dial of Ahaz, The . . . . 841<sup>a</sup> (Maunder)  
 Analysis and meaning  
 of the sign . . . . . 842<sup>a</sup>  
 "Dial," signifies a stair-  
 case . . . . . 841<sup>b</sup>  
 Fifteen "songs of de-  
 grees" . . . . . 842<sup>b</sup>  
 Hezekiah's sickness and  
 the sign . . . . . 841<sup>a</sup>  
 Sign, a real miracle . . . 841<sup>b</sup>  
 Diamond  
 of Stones, Precious . . . 2856<sup>a</sup> (Fletcher)  
 Diana . . . . . 842<sup>b</sup> (Banks)  
 Diana, Temple of . . . . . 961<sup>b</sup> (Banks)



- Diaspora  
 cf Dispersion . . . . . 855<sup>a</sup> (Nicol)
- Diblah . . . . . 843<sup>b</sup>
- Diblam . . . . . 843<sup>b</sup>
- Diblath  
 cf Diblah . . . . . 843<sup>b</sup>
- Diblathaim  
 cf Almon-diblathaim . . . 100<sup>a</sup>
- Dibon, Dibon-gad . . . . . 843<sup>b</sup> (Ewing)
- Dibri . . . . . 843<sup>b</sup>
- Dice-playing  
 cf Games . . . . . 1168<sup>b</sup> (Smith)
- Dictionaries . . . . . 843<sup>b</sup> (Richardson)
- Art and music . . . . . 847<sup>b</sup>
- Bible dictionaries . . . . . 844<sup>a</sup>
- Bibliography . . . . . 844<sup>b</sup>
- Biographical . . . . . 848<sup>a</sup>
- Comparative religion . 845<sup>b</sup>
- Denominational dic-  
   tionaries . . . . . 846<sup>a</sup>
- Geography . . . . . 848<sup>a</sup>
- Language . . . . . 848<sup>a</sup>
- Philosophical . . . . . 847<sup>a</sup>
- Religious encyclopae-  
   dias . . . . . 845<sup>a</sup>
- Universal encyclopae-  
   dias . . . . . 846<sup>a</sup>
- Didache . . . . . 387<sup>b</sup> (A. T. Robertson);  
   390<sup>a</sup> (T. M. Lindsay);  
   481<sup>a</sup> (Lowndes)
- cf Literature, Sub-  
   apoc . . . . . 1898<sup>a</sup> (Cowan)
- cf Teach, Teacher,  
   Teaching . . . . . 2923<sup>b</sup> (DeMent)
- Didrachma . . . . . 848<sup>b</sup>; 872<sup>b</sup>
- Didymus . . . . . 848<sup>b</sup>
- Die . . . . . 848<sup>b</sup> (W. L. Walker)
- Diet . . . . . 848<sup>b</sup>
- Dig . . . . . 849<sup>a</sup> (M. O. Evans)
- Dignities, Dignity . . . . 849<sup>a</sup>
- Dike . . . . . 849<sup>a</sup>
- cf Justice . . . . . 1781<sup>b</sup> (Rall)
- Diklah . . . . . 849<sup>a</sup>
- Dilean . . . . . 849<sup>a</sup>
- Diligence, Diligent, Dili-  
 gently . . . . . 849<sup>a</sup> (Gerberding)
- Dill  
 cf Anise . . . . . 136<sup>a</sup> (Masterman)
- Diminish . . . . . 849<sup>a</sup>
- Dimnah . . . . . 849<sup>a</sup>
- cf Rimmon (place) . . . 2593<sup>b</sup> (Masterman)
- Dimon, Dimonah  
 cf Dibon . . . . . 843<sup>b</sup> (Ewing)
- Dinah . . . . . 849<sup>b</sup> (N. Isaacs)
- Dinaites . . . . . 849<sup>b</sup>
- Dinhabah . . . . . 849<sup>b</sup>
- Dinner . . . . . 849<sup>b</sup> (Eager)
- cf Meals . . . . . 2013<sup>b</sup> (Eager)
- Diognetus, Epistle to  
 cf Literature, Sub-  
 apoc . . . . . 1904<sup>b</sup> (Cowan)
- Dionysia . . . . . 849<sup>b</sup> (Harry)
- Greater festivals . . . . 850<sup>a</sup>
- Rural festival . . . . . 849<sup>b</sup>
- Dionysius . . . . . 850<sup>a</sup> (Harry)
- Dionysus (Bacchus) . . . . 850<sup>a</sup> (Harry)
- cf Bacchus . . . . . 376<sup>a</sup> (Rees)
- cf Hellenism, Hellen-  
   ist . . . . . 1371<sup>a</sup> (Heidel)
- Dioscorinthius . . . . . 850<sup>b</sup>
- cf Calendar . . . . . 541<sup>b</sup> (Porter)
- cf Time . . . . . 2981<sup>b</sup> (Porter)
- Dioscuro . . . . . 851<sup>a</sup> (Maunder)
- cf Sign . . . . . 2789<sup>a</sup> (Stuart)
- Diotrephes . . . . . 851<sup>a</sup>
- cf John, The Epistles  
   of . . . . . 1718<sup>b</sup> (Law)
- Dip . . . . . 851<sup>a</sup> (Breslich)
- Diphath . . . . . 851<sup>a</sup>
- cf Riphath . . . . . 2594<sup>b</sup>
- Disallow . . . . . 851<sup>a</sup>
- Disannul  
 cf Annul . . . . . 137<sup>b</sup> (Hirsch)
- Disappoint . . . . . 851<sup>a</sup>
- Discern . . . . . 851<sup>a</sup> (Dosker)
- Discernings of Spirits . . 851<sup>b</sup> (Fortune)
- cf Spiritual Gifts . . . 2843<sup>b</sup> (Lambert)
- Disciple . . . . . 851<sup>b</sup> (Trever)
- Discipline . . . . . 852<sup>a</sup>
- cf Chastisement . . . . 598<sup>b</sup> (Jacobs)
- Discomfit, Discomfiture . 852<sup>a</sup> (Clippinger)
- Discourse . . . . . 852<sup>a</sup>
- Discover . . . . . 852<sup>a</sup> (Stearns)
- Discrepancies, Biblical . 852<sup>b</sup> (Van Pelt)
- Alleged discrepancies  
   as to doctrine . . . . . 853<sup>b</sup>
- Alleged discrepancies  
   as to fact . . . . . 853<sup>a</sup>
- Causes of discrepan-  
   cies . . . . . 853<sup>b</sup>
- Criticism v. inerrancy . 852<sup>b</sup>
- Nature of arguments . 852<sup>b</sup>
- Significance for faith . 854<sup>a</sup>
- cf Virgin-birth of Jesus  
   Christ . . . . . 3054<sup>a</sup> (Sweet)
- Discus . . . . . 854<sup>a</sup> (W. L. Walker)
- cf Games . . . . . 1168<sup>b</sup> (Smith)
- Disease, Diseases . . . . . 854<sup>b</sup> (Macalister)
- cf Sick, Sickness . . . . 2783<sup>a</sup> (Macalister)
- Diseases of the Eye . . . . 1070<sup>a</sup> (Macalister)
- Dish . . . . . 854<sup>b</sup> (Downer)
- Dishan, Dishon . . . . . 854<sup>b</sup>
- Dishonesty . . . . . 854<sup>b</sup>
- Disobedience, Disobedi-  
 ent . . . . . 854<sup>b</sup> (Clippinger)
- cf Obedience . . . . . 2175<sup>a</sup> (Clippinger)
- cf Sin . . . . . 2798<sup>b</sup> (McConnell)
- Disorderly . . . . . 855<sup>a</sup> (Dosker)
- Dispatch . . . . . 855<sup>a</sup>
- Dispensation . . . . . 855<sup>a</sup>
- Dispersion, The . . . . . 855<sup>a</sup> (Nicol)
- Alexandrian Judaism . . 857<sup>a</sup>
- Among Greeks proper . 858<sup>a</sup>

- Dispersion, The—*continued*  
 In Asia Minor . . . . . 857<sup>b</sup>  
 Causes . . . . . 855<sup>b</sup>  
 Eastern Dispersion . . . . . 856<sup>a</sup>  
 Egyptian Dispersion . . . . . 856<sup>a</sup>  
 Importance of discovery . . . . . 856<sup>b</sup>  
 Jewish Temple at  
 Syene . . . . . 856<sup>b</sup>  
 Testimony of Aramaic papyri . . . . . 856<sup>a</sup>  
 Extent . . . . . 855<sup>b</sup>  
 Golah and Diaspora . . . . . 855<sup>a</sup>  
 Influence . . . . . 859<sup>a</sup>  
 Internal organization . . . . . 859<sup>a</sup>  
 In Italy, Gaul, Spain,  
 and North Africa . . . . . 858<sup>b</sup>  
 Jews and Hellenism . . . . . 857<sup>a</sup>  
 Nations, Dispersion of  
 cf Babel . . . . . 349<sup>a</sup> (Clay)  
 cf Table of Nations . . . . . 2898<sup>b</sup> (Pinches)  
 Numbers . . . . . 858<sup>b</sup>  
 Proselytism . . . . . 858<sup>b</sup>  
 Purpose . . . . . 855<sup>b</sup>  
 Roman Dispersion . . . . . 858<sup>a</sup>  
 Influence in early  
 Roman Empire . . . . . 858<sup>b</sup>  
 Jews and first  
 Caesars . . . . . 858<sup>b</sup>  
 cf Roman Empire  
 and Christianity . . . . . 2600<sup>a</sup> (Angus)  
 Septuagint . . . . . 857<sup>b</sup>  
 cf Septuagint . . . . . 2722<sup>a</sup> (Thackeray)  
 In Syria . . . . . 857<sup>b</sup>  
 Disposition . . . . . 859<sup>b</sup>  
 Disputation . . . . . 859<sup>b</sup>  
 Distaff . . . . . 859<sup>b</sup>  
 cf Spinning . . . . . 2841<sup>a</sup> (Patch)  
 Distil . . . . . 859<sup>b</sup>  
 Distinctly . . . . . 859<sup>b</sup>  
 Ditch . . . . . 859<sup>b</sup> (Clippinger)  
 Divers, Diverse, Diversities . . . . . 859<sup>b</sup> (Breslich)  
 Dives  
 cf Hades . . . . . 1315<sup>a</sup> (Vos)  
 cf Lazarus . . . . . 1860<sup>a</sup> (Trevor)  
 Divide . . . . . 860<sup>a</sup> (Breslich)  
 Divide Asunder . . . . . 316<sup>b</sup> (S. F. Hunter)  
 Divination . . . . . 860<sup>a</sup> (T. W. Davies); 296<sup>b</sup>  
 (Maunder)  
 In ancient Greece . . . . . 1300<sup>b</sup> (Fairbanks)  
 Bible and divination . . . . . 861<sup>a</sup>  
 Divination and prophecy . . . . . 862<sup>b</sup>  
 Fundamental assumption . . . . . 860<sup>b</sup>  
 Astrology . . . . . 860<sup>b</sup>  
 cf Astrology . . . . . 296<sup>b</sup> (Maunder)  
 Hepatoscopy . . . . . 860<sup>b</sup>  
 Oracles . . . . . 860<sup>b</sup>  
 Origin of word . . . . . 860<sup>b</sup>  
 cf Greece, Religion in . . . . . 1301<sup>a</sup> (Fairbanks)
- Divination—*continued*  
 cf Inquire . . . . . 1472<sup>b</sup> (M. O. Evans)  
 Kinds . . . . . 860<sup>a</sup>  
 cf Augury . . . . . 331<sup>a</sup> (T. W. Davies)  
 Legitimate and illegitimate . . . . . 860<sup>b</sup>  
 cf Liver . . . . . 1905<sup>b</sup> (Luering)  
 cf Magi, The . . . . . 1962<sup>a</sup> (Tisdall)  
 cf Magic, Magician . . . . . 1964<sup>b</sup> (T. W. Davies)  
 Modes of divination . . . . . 861<sup>b</sup>  
 Condemned methods . . . . . 862<sup>a</sup>  
 Dreams . . . . . 861<sup>b</sup>  
 Hydromancy . . . . . 862<sup>a</sup>  
 Sortilege . . . . . 861<sup>b</sup>  
 cf Oracle . . . . . 2198<sup>b</sup> (Easton)  
 cf Orator . . . . . 2199<sup>a</sup> (Edwards)  
 cf Poetry, Hebrew . . . . . 2413<sup>b</sup> (T. W. Davies)  
 cf Prophecy . . . . . 2466<sup>a</sup> (Orelli)  
 cf Python . . . . . 2511<sup>b</sup> (Easton)  
 cf Vault . . . . . 3046<sup>b</sup>  
 cf Wise Men . . . . . 3096<sup>b</sup> (Easton)  
 cf Witch . . . . . 3097<sup>a</sup> (T. W. Davies)  
 Divine, Diviner  
 cf Astrology . . . . . 296<sup>b</sup> (Maunder)  
 cf Augury . . . . . 331<sup>a</sup> (T. W. Davies)  
 cf Divination . . . . . 860<sup>a</sup> (T. W. Davies)  
 Divine Names  
 cf God, Names of . . . . . 1264<sup>b</sup> (Mack)  
 Divine Visitation  
 cf Punishments . . . . . 2504<sup>b</sup> (Hirsch)  
 Division . . . . . 863<sup>a</sup> (Edwards)  
 Divorce in NT . . . . . 865<sup>a</sup> (Caverno)  
 Christ's teachings . . . . . 865<sup>b</sup>  
 cf Family . . . . . 1094<sup>b</sup> (Caverno)  
 cf Hammurabi, Code  
 of . . . . . 1330<sup>a</sup> (Ungnad)  
 cf Jesus Christ . . . . . 1653<sup>b</sup> (Orr)  
 cf Law in NT . . . . . 1845<sup>a</sup> (M'Caig)  
 cf Marriage . . . . . 1999<sup>a</sup> (Eager)  
 Paul's teachings . . . . . 866<sup>a</sup>  
 cf Polygamy . . . . . 2416<sup>a</sup> (Caverno)  
 cf Purity . . . . . 2509<sup>a</sup> (Caverno)  
 Remedies for marriage  
 ills . . . . . 866<sup>b</sup>  
 cf Family . . . . . 1094<sup>b</sup> (Caverno)  
 Divorce in OT . . . . . 863<sup>b</sup> (W. W. Davies)  
 cf Adultery . . . . . 63<sup>a</sup> (Margolis)  
 Divorce applicable  
 only to wives . . . . . 864<sup>a</sup>  
 Grounds for divorce . . . . . 864<sup>a</sup>  
 Law . . . . . 863<sup>b</sup>  
 Position of woman . . . . . 863<sup>b</sup>  
 Process and exceptions . . . . . 864<sup>a</sup>  
 Di-zahab . . . . . 866<sup>b</sup> (Ewing)  
 Docetism  
 In 1 John . . . . . 1713<sup>a</sup> (Law)  
 Doctor . . . . . 866<sup>b</sup>  
 cf Education . . . . . 900<sup>b</sup> (Meyer)  
 cf Rabbi . . . . . 2522<sup>a</sup> (Pollard)  
 cf Scribes . . . . . 2704<sup>b</sup> (Hirsch)  
 Doctrine . . . . . 866<sup>b</sup> (Rees)  
 Apostolic doctrines . . . . . 867<sup>a</sup>

- Doctrine—*continued*  
   Beginnings of dogma .867<sup>a</sup>  
   cf Dogma .868<sup>a</sup> (Rees)  
   Christ's teachings in-  
   formal .867<sup>a</sup>  
 Docus  
   cf Dok .868<sup>b</sup> (Hutchison)  
 Dodai  
   cf Dodo .867<sup>b</sup>  
 Dodanim .867<sup>b</sup>  
   cf Rodanim .2597<sup>a</sup>  
 Dodavahu .867<sup>b</sup>  
 Dodo, Dodai .867<sup>b</sup>  
 Doe  
   cf Deer .817<sup>a</sup> (Day)  
   cf Roe, Roebuck .2597<sup>a</sup> (Day)  
 Doeg .867<sup>b</sup> (N. Isaacs)  
 Dog .867<sup>b</sup> (Day)  
   cf Price .2439<sup>a</sup>  
 Dogma .868<sup>a</sup> (Rees)  
   cf Comparative Re-  
   ligion .693<sup>b</sup> (Tisdall)  
 Dok .868<sup>b</sup> (Hutchison)  
 Doleful .868<sup>b</sup>  
 Dolphin  
   cf Badger .376<sup>b</sup> (Day)  
 Dominion .869<sup>a</sup>  
   cf Angel .132<sup>b</sup> (J. M. Wilson)  
 Doom .869<sup>a</sup> (Van Pelt)  
 Door .869<sup>a</sup> (Downer)  
   cf Achor .37<sup>a</sup> (Beecher)  
   cf Gate .1175<sup>b</sup> (Easton)  
   cf House .1434<sup>b</sup> (A. C. Dickie)  
   cf Shepherd .2763<sup>a</sup> (Patch)  
 Doorkeeper .869<sup>a</sup> (Hovey)  
   cf Port, Porter .2422<sup>a</sup> (Easton)  
   cf Priests and Levites .2446<sup>b</sup> (Wiener)  
 Doorpost  
   cf House .1434<sup>b</sup> (A. C. Dickie)  
 Dophkah .869<sup>b</sup>  
   cf Wanderings of  
   Israel .3064<sup>a</sup> (Conder)  
 Dor, Dora .869<sup>b</sup> (Porter)  
 Dorcas .870<sup>a</sup> (S. F. Hunter)  
 Dorymenes .870<sup>a</sup>  
 Dositheus .870<sup>a</sup> (Hutchison)  
 Dotaea .870<sup>a</sup>  
 Dote .870<sup>b</sup>  
 Dothaim .870<sup>b</sup>  
 Dothan .870<sup>b</sup> (Ewing)  
 Double .870<sup>b</sup> (Clippinger)  
 Doubt .871<sup>b</sup> (Gray)  
   cf Disputation .859<sup>b</sup>  
 Dough  
   cf Bread .514<sup>b</sup> (Eager)  
 Dove .871<sup>a</sup> (Stratton-Porter)  
   cf Pigeon .2395<sup>a</sup> (Stratton-Porter)  
 Dove's Dung .872<sup>b</sup> (Stratton-Porter)  
 Dowry .872<sup>b</sup> (Pollard)  
 Doxology .872<sup>b</sup> (M. O. Evans)  
 Drachma, Dram .872<sup>b</sup>  
 Dragoman  
   cf Targum .2910<sup>b</sup> (J. E. H. Thomson)  
 Dragon .873<sup>a</sup> (Day)  
   cf Astronomy .300<sup>b</sup> (Maunder)  
   cf Bel and the .427<sup>b</sup> (T. W. Davies)  
   cf Fox .1144<sup>a</sup> (Day)  
   cf Jackal .1548<sup>a</sup> (Day)  
 Red  
   cf Revelation of  
   John .2582<sup>b</sup> (Orr)  
   cf Sea-monster .2707<sup>a</sup> (Day)  
   cf Waterspout .3075<sup>a</sup> (Day)  
   cf Whale .3082<sup>a</sup> (Day)  
   cf Whelp .3083<sup>a</sup> (Day)  
 Dragon Well  
   cf Jackal's Well .1548<sup>b</sup> (Masterman)  
 Dram  
   cf Drachma .872<sup>b</sup>  
   cf Money .2076<sup>a</sup> (Porter)  
 Drama, Mimic  
   cf Games .1168<sup>b</sup> (Smith)  
 Draught .873<sup>b</sup>  
 Drawer of Water .873<sup>b</sup> (Patch)  
   cf Hewer .1384<sup>b</sup> (Patch)  
 Dream, Dreamer .874<sup>a</sup> (Clippinger)  
   cf Greece, Religion in .1301<sup>a</sup> (Fairbanks)  
 Dredge .875<sup>b</sup>  
 Dregs .875<sup>b</sup>  
 Drehem .365<sup>b</sup> (Clay)  
 Dress .875<sup>b</sup> (Eager)  
   cf Adorn .61<sup>b</sup> (Kapp)  
   cf Fisher's Coat .1116<sup>a</sup>  
   Footgear .879<sup>a</sup>  
   cf Fringes .1146<sup>b</sup> (E. D. Isaacs)  
   cf Frock .1147<sup>a</sup> (E. D. Isaacs)  
   cf Handkerchief .1334<sup>b</sup>  
   Headdress .878<sup>a</sup>  
   cf Hem .1374<sup>a</sup> (Eager)  
   cf Hood .1419<sup>a</sup>  
   Of Jesus and His disci-  
   ples .879<sup>a</sup>  
   cf Jewel .1675<sup>b</sup> (Orr)  
   cf Mantle .1984<sup>a</sup>  
   Materials .876<sup>b</sup>  
   cf Meals, Meal-time .2015<sup>b</sup> (Eager)  
   Meaning of terms .876<sup>a</sup>  
   cf Muffler .2093<sup>b</sup>  
   cf Napkin .2119<sup>b</sup>  
   Outer garments .877<sup>a</sup>  
   cf Priests and Levites .2452<sup>a</sup> (Wiener)  
   cf Shawl .2752<sup>a</sup>  
   Under garments .877<sup>b</sup>  
   cf Veil .3047<sup>a</sup> (Easton)  
   cf Wimple .3085<sup>b</sup>  
 Drink  
   cf Drink, Strong .879<sup>b</sup> (Edwards)  
   cf Food .1121<sup>b</sup> (Eager)  
   cf Offering .2645<sup>b</sup> (Reeve)  
 Drink, Strong .879<sup>b</sup> (Edwards)  
   cf Liquor .1896<sup>a</sup>  
   cf Temperance, Tem-  
   perate .2929<sup>b</sup> (Jacobs)  
   cf Wine .3086<sup>b</sup> (Easton)

- Drive Asunder . . . . . 316<sup>b</sup> (S. F. Hunter)  
 Dromedary  
   of Camel . . . . . 547<sup>b</sup> (Day)  
 Drop, Dropping . . . . . 880<sup>a</sup>  
 Dropsy . . . . . 880<sup>a</sup>  
 Dross . . . . . 880<sup>a</sup>  
 Drought  
   of Famine . . . . . 1097<sup>a</sup> (W. L. Walker)  
 Drove  
   of Cattle . . . . . 583<sup>b</sup> (Day)  
 Drowning  
   of Punishments . . . . . 2504<sup>b</sup> (Hirsch)  
 Drum . . . . . 880<sup>a</sup>  
   of Music . . . . . 2101<sup>a</sup> (Millar)  
 Drunkenness . . . . . 880<sup>b</sup> (Edwards)  
   of Drink, Strong . . . . . 879<sup>b</sup> (Edwards)  
   of Wine . . . . . 3088<sup>a</sup> (Easton)  
 Drusilla . . . . . 881<sup>b</sup> (Kerr)  
 Dry  
   of Ground . . . . . 1307<sup>a</sup> (W. L. Walker)  
 Dualism  
   of Philosophy . . . . . 2383<sup>a</sup> (Rees)  
 Due  
   of Duty . . . . . 883<sup>b</sup> (W. L. Walker)  
 Duke . . . . . 882<sup>a</sup> (Van Pelt)  
   of Chief . . . . . 606<sup>a</sup> (Farr)  
 Dulcimer  
   of Music . . . . . 2094<sup>b</sup> (Millar)  
 Dumah . . . . . 882<sup>a</sup> (Weir)  
 Dumb . . . . . 882<sup>a</sup> (Macalister)  
 Dung . . . . . 882<sup>b</sup> (Patch)  
 Dung Gate . . . . . 882<sup>b</sup> (Patch)  
 Dungeon  
   of Prison . . . . . 2456<sup>a</sup> (T. Lewis)  
 Dunghill . . . . . 882<sup>b</sup>  
   of Dung . . . . . 882<sup>b</sup> (Patch)  
 Dunkers  
   of Lord's Supper . . . . . 1929<sup>a</sup> (Kurtz)  
 Dura . . . . . 883<sup>a</sup> (Pinches)  
 Dure . . . . . 883<sup>a</sup>  
   of Endure . . . . . 944<sup>b</sup>  
 Dust . . . . . 883<sup>a</sup> (Edwards)  
   of Rolling Thing . . . . . 2597<sup>b</sup>  
 Duty . . . . . 883<sup>b</sup> (W. L. Walker)  
   of Ethics . . . . . 1013<sup>a</sup> (Alexander)  
 Dwarf . . . . . 883<sup>b</sup> (Farr)  
   of Priests and Levites . . . . . 2446<sup>b</sup> (Wiener)  
 Dwell . . . . . 883<sup>b</sup> (Edwards)  
   of Inhabit . . . . . 1468<sup>a</sup> (Edwards)  
 Dye, Dyeing . . . . . 883<sup>b</sup> (Patch)  
   of Colors . . . . . 674<sup>b</sup> (Patch)  
   of Purple . . . . . 2509<sup>b</sup> (Day)  
   of Rams' Skins . . . . . 2530<sup>a</sup>  
   of Tanner . . . . . 2908<sup>b</sup> (Patch)  
   of Thyatira . . . . . 2977<sup>b</sup> (Banks)  
 Dysentery . . . . . 884<sup>b</sup> (Macalister)  
 Ea . . . . . 370<sup>b</sup> (Rogers)  
 Eagle . . . . . 885<sup>a</sup> (Stratton-Porter)  
 Eanes (Manes) . . . . . 1981<sup>a</sup>  
 Ear . . . . . 886<sup>b</sup> (Luering)  
 Earring . . . . . 886<sup>b</sup>  
   Early . . . . . 886<sup>b</sup> (Gerberding)  
   Earnest . . . . . 886<sup>b</sup> (Schenk)  
     of Pledge . . . . . 2408<sup>b</sup> (Easton)  
   Earring . . . . . 887<sup>a</sup> (Eager)  
     of Amulet . . . . . 126<sup>b</sup> (T. W. Davies)  
     of Ornament . . . . . 2201<sup>b</sup> (Doolan)  
     of Ring . . . . . 2594<sup>a</sup> (Crannell)  
   Earth . . . . . 887<sup>a</sup> (Day)  
     of Anthropology . . . . . 144<sup>b</sup> (Marais)  
   Circle of the  
     of Astronomy . . . . . 314<sup>b</sup> (Maunder)  
   Corners of the . . . . . 887<sup>a</sup>  
     of Astronomy . . . . . 315<sup>a</sup> (Maunder)  
   of Evolution . . . . . 1043<sup>a</sup> (Zenos)  
   of Heavens, New . . . . . 1353<sup>a</sup> (Vos)  
   of Land . . . . . 1826<sup>b</sup> (Day)  
   New  
     of Eschatology of  
       NT . . . . . 979<sup>b</sup> (Vos)  
   Pillars of the  
     of Astronomy . . . . . 315<sup>a</sup> (Maunder)  
   Vault of the . . . . . 887<sup>b</sup>  
     of Astronomy . . . . . 315<sup>a</sup> (Maunder)  
   of World, Cosmological . . . . . 3106<sup>a</sup> (Orr)  
   Earthen Vessels . . . . . 887<sup>b</sup> (Patch)  
     of Potter . . . . . 2423<sup>b</sup> (Patch)  
   Earthly . . . . . 887<sup>b</sup> (Edwards)  
   Earthquake . . . . . 888<sup>a</sup> (Joy)  
     Causes of . . . . . 888<sup>a</sup>  
     In Jerusalem . . . . . 888<sup>a</sup>  
     In Palestine . . . . . 888<sup>a</sup>  
     In Scripture . . . . . 888<sup>b</sup>  
     Symbolic use . . . . . 888<sup>b</sup>  
   Ease . . . . . 888<sup>b</sup> (Clippinger)  
   East  
     of Natural Features . . . . . 2122<sup>a</sup> (Day)  
   East, Children of the . . . . . 888<sup>b</sup> (Day)  
   East Country . . . . . 889<sup>a</sup>  
   East Gate . . . . . 1176<sup>b</sup> (Caldecott)  
     of Tabernacle . . . . . 2889<sup>a</sup> (Caldecott; Orr)  
   East Sea  
     of Dead Sea . . . . . 801<sup>a</sup> (Wright)  
   East Wind  
     of Wind . . . . . 3085<sup>b</sup> (Joy)  
   Easter . . . . . 889<sup>a</sup> (Porter)  
   Ebal . . . . . 889<sup>b</sup>  
   Ebal, Mount . . . . . 889<sup>b</sup> (Ewing)  
   Ebed . . . . . 890<sup>b</sup>  
   Ebed-melech . . . . . 890<sup>b</sup> (Farr)  
   Eben-bohan (Bohan) . . . . . 494<sup>a</sup>  
   Eben-ezel (Ezel) . . . . . 1081<sup>b</sup>  
   Eben-ezer . . . . . 890<sup>b</sup> (Ewing)  
   Eber . . . . . 890<sup>b</sup> (Grant)  
     of Heber . . . . . 1354<sup>b</sup> (Pollard)  
     of Semites . . . . . 2717<sup>a</sup> (Mack)  
   Ebez . . . . . 890<sup>b</sup>  
     of Abez . . . . . 6<sup>b</sup>  
   Ebiasaph . . . . . 890<sup>b</sup>  
     of Abiasaph . . . . . 7<sup>b</sup> (Beecher)  
   Ebionism, Ebionites . . . . . 890<sup>b</sup> (J. E. H. Thomson)  
     Account of . . . . . 891<sup>b</sup>

- Ebionism—continued**  
 Christology of early  
   church . . . . . 893<sup>b</sup>  
 History of . . . . . 892<sup>a</sup>  
 Literature of . . . . . 892<sup>a</sup>  
 Origin of name . . . . . 891<sup>b</sup>  
 Paulinism of early  
   church . . . . . 894<sup>a</sup>
- Ebionites, Apocryphal**  
 Gospel of . . . . . 197<sup>a</sup> (Hutchison)
- Ebony** . . . . . 894<sup>a</sup> (Masterman)
- Ebron** . . . . . 894<sup>b</sup>  
 cf Abdon . . . . . 4<sup>b</sup> (Beecher)  
 cf Hebron . . . . . 1365<sup>a</sup> (Masterman)
- Ebronah (Abronah)** . . . . . 23<sup>a</sup>
- Ecanus (Ethanus)** . . . . . 1012<sup>b</sup>
- Ecbatana**  
 cf Raphael . . . . . 2532<sup>b</sup> (J. E. H. Thomson)
- Ecce Homo** . . . . . 894<sup>b</sup> (Clippinger)
- Ecclesiastes** . . . . . 894<sup>b</sup> (Beecher)  
 Canonicity . . . . . 897<sup>a</sup>  
 Composite authorship . 895<sup>b</sup>  
 Contents . . . . . 895<sup>a</sup>  
 Date and authorship . 896<sup>a</sup>  
 cf Games . . . . . 1168<sup>b</sup> (Smith)  
 "King in Jerusalem" . 896<sup>a</sup>  
 Koheleth . . . . . 896<sup>a</sup>  
 Linguistic peculiarities 896<sup>b</sup>  
 Structure of book . . . 895<sup>a</sup>
- Ecclesiasticus**  
 cf Games . . . . . 1168<sup>b</sup> (Smith)  
 cf Jerusalem . . . . . 1617<sup>a</sup> (Masterman)  
 cf Prologue . . . . . 2458<sup>b</sup>  
 cf Septuagint . . . . . 2724<sup>b</sup> (Thackeray)  
 cf Sirach, Book of . . . 2806<sup>b</sup> (T. W. Davies)
- Eclipse**  
 cf Astronomy . . . . . 303<sup>b</sup>; 310<sup>a</sup> (Maunder)
- Ed** . . . . . 897<sup>a</sup> (Wright)
- Edar (Eder)** . . . . . 899<sup>a</sup>
- Eddias (Ieddias)** . . . . . 1448<sup>b</sup>
- Eddinus** . . . . . 897<sup>b</sup>
- Eden (garden)** . . . . . 897<sup>b</sup> (Wright)  
 Archaeological theory . 229<sup>b</sup> (Kyle)  
 Armenia . . . . . 898<sup>a</sup>  
 Babylonia . . . . . 898<sup>a</sup>  
 Central Asia . . . . . 897<sup>b</sup>  
 cf Gihon . . . . . 1228<sup>b</sup> (Masterman)  
 cf Hiddekel . . . . . 1388<sup>b</sup> (Wright)  
 North Pole . . . . . 898<sup>a</sup>  
 cf Shinar . . . . . 2771<sup>b</sup> (Pinches)  
 cf Telassar . . . . . 2925<sup>a</sup> (Pinches)  
 cf Tigris . . . . . 2981<sup>a</sup> (Wright)
- Eden, Children of** . . . . . 607<sup>b</sup> (Fortune)
- Eden, House of**  
 cf Aven . . . . . 340<sup>a</sup>  
 cf Betheden . . . . . 897<sup>b</sup> (Wright)  
 cf Children of Eden . . 607<sup>b</sup> (Fortune)
- Eder (person)** . . . . . 899<sup>a</sup>  
 cf Ader . . . . . 55<sup>b</sup>
- Eder (place)** . . . . . 899<sup>a</sup> (Masterman)
- Edes (Edos)** . . . . . 900<sup>b</sup>
- Edge** . . . . . 899<sup>a</sup>
- Edification** . . . . . 899<sup>a</sup> (Farr)
- Edna** . . . . . 899<sup>a</sup>
- Edom, Edomites** . . . . . 899<sup>a</sup> (Ewing)  
 Boundaries . . . . . 899<sup>a</sup>  
 Character and features 899<sup>b</sup>  
 History . . . . . 900<sup>a</sup>  
 Idumaea and the Idu-  
   maeans . . . . . 900<sup>a</sup>  
 cf Jehoram . . . . . 1581<sup>b</sup> (Mosiman)  
 Origin of name . . . . . 899<sup>b</sup>  
 cf Seir . . . . . 2713<sup>a</sup> (Ewing)  
 cf Sela . . . . . 2713<sup>b</sup> (Ewing)
- Edos** . . . . . 900<sup>b</sup>
- Edrei** . . . . . 900<sup>b</sup> (Ewing)
- Education** . . . . . 900<sup>b</sup> (Meyer)  
 Definition of . . . . . 900<sup>b</sup>  
 In early Israel . . . . . 901<sup>a</sup>  
 Deuteronomic legis-  
   lation . . . . . 901<sup>b</sup>  
 Monarchical period . 901<sup>b</sup>  
 Nomadic and agri-  
   cultural periods . . . 901<sup>a</sup>  
 Reading and writing . 902<sup>a</sup>  
 cf Jehoshaphat . . . . . 1582<sup>a</sup> (Mosiman)  
 In later Israel . . . . . 902<sup>a</sup>  
 Book of the law . . . . 902<sup>b</sup>  
 Book of Proverbs . . . 903<sup>a</sup>  
 Educational signifi-  
   cance of the  
   prophets . . . . . 902<sup>b</sup>  
 Greek and Roman  
   influences . . . . . 903<sup>b</sup>  
 Scribes and Levites . 903<sup>a</sup>  
 Wise men . . . . . 902<sup>b</sup>  
 In NT times . . . . . 903<sup>b</sup>  
 Educational work of  
   early disciples . . . 904<sup>b</sup>  
 Method and aims . . . 904<sup>a</sup>  
 Pre-eminence of Jesus  
   as a teacher . . . . . 904<sup>b</sup>  
 Subject-matter of  
   instruction . . . . . 904<sup>a</sup>  
 Valuable results of  
   Jewish education . . . 904<sup>a</sup>  
 cf Schoolmaster . . . . . 2702<sup>b</sup> (Easton)  
 cf Synagogue . . . . . 2878<sup>b</sup> (Levertoff)  
 cf Teach . . . . . 2921<sup>a</sup> (DeMent)  
 cf Tutor . . . . . 3028<sup>a</sup>
- Eduth**  
 cf Psalms, Book of . . . 2487<sup>a</sup> (Sampey)
- Effect** . . . . . 905<sup>a</sup> (Farr)
- Egg** . . . . . 905<sup>b</sup> (Stratton-Porter)  
 cf Food . . . . . 1124<sup>a</sup> (Eager)
- Eglah** . . . . . 905<sup>b</sup>
- Eglaim** . . . . . 905<sup>b</sup>
- Eglath-shelishiyah** . . . . . 905<sup>b</sup> (Ewing)  
 cf Heifer . . . . . 1367<sup>b</sup> (Easton)  
 cf Palestine . . . . . 2219<sup>a</sup> (Conder)
- Eglon (person)** . . . . . 905<sup>b</sup> (E. D. Isaacs)
- Eglon (place)** . . . . . 996<sup>a</sup> (Ewing)

- Egypt . . . . . 906<sup>a</sup> (Petrie)  
   Brook of . . . . . 523<sup>b</sup> (Kyle)  
     of Shihar . . . . . 2768<sup>a</sup> (Kyle)  
   Civilization . . . . . 914<sup>a</sup>  
     Character . . . . . 915<sup>b</sup>  
     Foreign gods . . . . . 915<sup>b</sup>  
     Four groups of gods . . . . . 915<sup>a</sup>  
     Future life . . . . . 914<sup>b</sup>  
     Language . . . . . 914<sup>a</sup>  
     Laws . . . . . 915<sup>b</sup>  
     Literature . . . . . 914<sup>b</sup>  
     Writing . . . . . 914<sup>b</sup>  
   Country . . . . . 906<sup>a</sup>  
     Basis of land . . . . . 906<sup>a</sup>  
     Climate . . . . . 906<sup>b</sup>  
     Conditions of life . . . . . 907<sup>a</sup>  
     Earliest human re-  
       mains . . . . . 906<sup>b</sup>  
     Fauna . . . . . 907<sup>b</sup>  
     Flora . . . . . 907<sup>b</sup>  
     Nile . . . . . 907<sup>a</sup>  
     Nile Valley . . . . . 906<sup>b</sup>  
     Prehistoric races . . . . . 907<sup>b</sup>  
   History . . . . . 907<sup>b</sup>  
     Arabic . . . . . 909<sup>b</sup>  
     Dynasties . . . . . 908<sup>b</sup>; 909<sup>a</sup>  
     Early foreign con-  
       nections . . . . . 910<sup>a</sup>  
     Prehistoric . . . . . 908<sup>a</sup>  
     Roman times . . . . . 909<sup>b</sup>  
   of Mizraim . . . . . 2069<sup>b</sup> (Kyle)  
   of Nile . . . . . 2145<sup>a</sup> (Kyle)  
   OT connections . . . . . 910<sup>a</sup>  
     Abramic times . . . . . 910<sup>b</sup>  
     Circumcision . . . . . 910<sup>b</sup>  
     Cities and places . . . . . 913<sup>a</sup>  
     Descent into Egypt . . . . . 911<sup>a</sup>  
     Egyptian Jew . . . . . 913<sup>a</sup>  
     Ethiopians . . . . . 912<sup>b</sup>  
     Exodus . . . . . 911<sup>b</sup>  
     Hadad . . . . . 912<sup>a</sup>  
     Historic position . . . . . 911<sup>b</sup>  
     Hophra . . . . . 912<sup>b</sup>  
     Israel in Canaan . . . . . 912<sup>a</sup>  
     Jews at Syene . . . . . 912<sup>b</sup>  
     Joseph . . . . . 911<sup>a</sup>  
     New Jerusalem at  
       Oniah . . . . . 913<sup>a</sup>  
     Oppression . . . . . 911<sup>a</sup>  
     Pharaoh's daughter . . . . . 912<sup>b</sup>  
     Plagues . . . . . 911<sup>b</sup>  
     Semitic connections . . . . . 910<sup>a</sup>  
     Shishak . . . . . 912<sup>b</sup>  
     Tahpanhes . . . . . 912<sup>b</sup>  
     Zerakh . . . . . 912<sup>b</sup>  
   of Phoenicia . . . . . 2390<sup>a</sup> (Porter)  
   of Plagues of Egypt . . . . . 2403<sup>a</sup> (Kyle)  
   of Sevens . . . . . 2744<sup>a</sup>  
   of Ships and Boats . . . . . 2775<sup>b</sup> (Nicol)  
   of Sidon . . . . . 2785<sup>b</sup> (Porter)  
   of Slave, Slavery . . . . . 2815<sup>b</sup> (Raffety)  
   of Wisdom . . . . . 3089<sup>b</sup> (Easton)
- Egyptian, The . . . . . 916<sup>a</sup>  
 Egyptian Kings (later)  
   of Egypt . . . . . 906<sup>a</sup> (Petrie)  
   of Hophra . . . . . 2359<sup>b</sup> (Nicol)  
   of Necho . . . . . 2360<sup>a</sup> (Nicol)  
   of Pharaoh . . . . . 2359<sup>a</sup> (Kyle)  
   of Shishak . . . . . 2777<sup>b</sup> (Nicol)  
 Egyptian Versions  
   of Coptic Versions . . . . . 708<sup>b</sup> (Tisdall)  
 Egyptians, Gospel ac-  
   cording to the  
   of Apocryphal Gospels . . . . . 197<sup>a</sup> (Hutchison)  
 Ehi . . . . . 916<sup>a</sup>  
   of Ahiram . . . . . 86<sup>a</sup> (Beecher)  
 Ehud . . . . . 916<sup>a</sup> (Farr)  
 Either . . . . . 916<sup>a</sup>  
 Eker . . . . . 916<sup>a</sup>  
 Ekrebel . . . . . 916<sup>a</sup>  
 Ekron . . . . . 916<sup>a</sup> (Porter)  
   of Accaron . . . . . 27<sup>b</sup>  
 Ekronite . . . . . 916<sup>b</sup> (Porter)  
 El  
   of God, Names of . . . . . 1264<sup>b</sup> (Mack)  
 Ela . . . . . 916<sup>b</sup>  
 Eladah (Eleadah) . . . . . 924<sup>b</sup>  
 Elah . . . . . 916<sup>b</sup> (Mosiman)  
 Elah, Vale of . . . . . 916<sup>b</sup> (Masterman)  
 Elam (person) . . . . . 917<sup>a</sup> (Farr)  
 Elam, Elamites . . . . . 917<sup>a</sup> (Pinches)  
   of Shushan . . . . . 2782<sup>a</sup> (Pinches)  
 Elasa . . . . . 923<sup>a</sup>  
 Elasa . . . . . 923<sup>a</sup>  
   of Eleasah . . . . . 924<sup>b</sup> (Farr)  
   of Saloas . . . . . 2664<sup>a</sup>  
 Elath, Eloth . . . . . 923<sup>a</sup> (Ewing)  
 Elberith  
   of Baal-berith . . . . . 347<sup>a</sup>  
 El-beth-el . . . . . 923<sup>b</sup>  
 Elcia (Elkiah) . . . . . 938<sup>a</sup>  
 Eldaah . . . . . 923<sup>b</sup>  
 Eldad . . . . . 923<sup>b</sup>  
 Eldad and Modad, Book  
   of . . . . . 923<sup>b</sup> (Fortune)  
 Elder (NT) . . . . . 924<sup>a</sup> (Grant)  
   of Bishop . . . . . 478<sup>b</sup> (Dosker)  
   of Church Govern-  
     ment . . . . . 653<sup>b</sup> (Forrester)  
   of Ministry . . . . . 2059<sup>b</sup> (T. M. Lindsay)  
   of Presbyter . . . . . 2437<sup>b</sup> (Mack)  
 Elder (OT) . . . . . 923<sup>b</sup> (Stearns)  
 Elead . . . . . 924<sup>b</sup>  
 Eleadah . . . . . 924<sup>b</sup>  
 Elealeh . . . . . 924<sup>b</sup> (Ewing)  
 Eleasa (Elasa) . . . . . 923<sup>a</sup>  
 Eleasah . . . . . 924<sup>b</sup> (Farr)  
 Eleazar . . . . . 924<sup>b</sup> (S. F. Hunter)  
 Eleazurus (Eliasibus) . . . . . 929<sup>b</sup>  
 Elect . . . . . 925<sup>a</sup> (Dunelm)  
 Elect Lady . . . . . 925<sup>a</sup> (Law)  
   of Cyria . . . . . 773<sup>b</sup>  
   of John, Epistles of . . . . . 1719<sup>a</sup> (Law)  
   of Lady . . . . . 1821<sup>b</sup>

- Election . . . . . 925<sup>b</sup> (Dunelm)  
   Cognate and illustrative Biblical language . . . . . 926<sup>a</sup>  
   Considerations in relief of thought . . . . . 926<sup>b</sup>  
   Antinomies . . . . . 926<sup>b</sup>  
   Fatalism another thing . . . . . 927<sup>a</sup>  
   Moral aspects . . . . . 927<sup>a</sup>  
   Unknown future . . . . . 927<sup>b</sup>  
   "We know in part" . . . . . 927<sup>a</sup>  
   of Foreordain . . . . . 1131<sup>a</sup> (Orr)  
   Incidence upon community and individual . . . . . 926<sup>a</sup>  
   Mysterious element . . . . . 925<sup>b</sup>  
   Perseverance . . . . . 926<sup>b</sup>  
   of Predestination . . . . . 2435<sup>a</sup> (J. Lindsay)  
   Scope of . . . . . 926<sup>a</sup>  
   Word in Scripture . . . . . 925<sup>b</sup>  
 Electrum . . . . . 927<sup>b</sup> (Fortune)  
   of Buying . . . . . 533<sup>a</sup> (Eager)  
   of Metal . . . . . 2044<sup>a</sup> (Masterman)  
   of Stones, Precious . . . . . 2856<sup>a</sup> (Fletcher)  
 El-Elohe-Israel . . . . . 927<sup>b</sup> (Mack)  
   of God, Names of . . . . . 1267<sup>a</sup> (Mack)  
 El Elyon  
   of God, Names of . . . . . 1267<sup>a</sup> (Mack)  
 Element . . . . . 927<sup>b</sup>  
   of Principles . . . . . 2455<sup>a</sup>  
   of Rudiments . . . . . 2624<sup>b</sup> (Rutherford)  
 Eleph . . . . . 927<sup>b</sup>  
   of Nephtoah . . . . . 2134<sup>a</sup> (Masterman)  
 Elephant . . . . . 928<sup>a</sup>  
   of Behemoth . . . . . 427<sup>a</sup> (Day)  
   of Ivory . . . . . 1544<sup>b</sup> (Day)  
   of Maccabees, Books of . . . . . 1954<sup>a</sup> (T. W. Davies)  
 Elephantine  
   of Number . . . . . 2158<sup>a</sup> (Smith)  
   of Palestine, Recent  
     Exploration . . . . . 2223<sup>b</sup> (Cobern)  
   of Papyrus . . . . . 2239<sup>a</sup> (Goodspeed)  
   of Sacrifice (OT) . . . . . 2647<sup>b</sup> (Reeve)  
   of Sanballat . . . . . 2681<sup>b</sup> (R. D. Wilson)  
   of Sanctuary . . . . . 2688<sup>a</sup> (Wiener)  
   of Sevehneh . . . . . 2744<sup>a</sup>  
 Elephantine Papyri  
   of Israel, History of . . . . . 1525<sup>b</sup> (Orelli)  
 Elephantine-Syene Papyri . . . . . 856<sup>b</sup> (Nicol)  
 Eleutherus . . . . . 928<sup>a</sup>  
 Eleven Stars  
   of Astronomy . . . . . 309<sup>a</sup> (Maunder)  
 Eleven, The . . . . . 928<sup>a</sup> (Clippinger)  
 Elhanan . . . . . 928<sup>a</sup> (Sampey)  
   of Goliath . . . . . 1276<sup>b</sup> (Reeve)  
 Eli . . . . . 928<sup>b</sup> (Grant)  
   of Shiloh . . . . . 2769<sup>a</sup> (Ewing)  
 Eli, Eli, Lama Sabachthani (Eloi) . . . . . 939<sup>a</sup> (Clippinger)  
 Eliab . . . . . 928<sup>b</sup> (Farr)  
 Eliada . . . . . 928<sup>b</sup>  
 Eliadas . . . . . 928<sup>b</sup>  
 Eliadun (Iliadun) . . . . . 1449<sup>a</sup>  
 Elijah (Elijah) . . . . . 930<sup>b</sup> (Farr)  
 Elijahba . . . . . 929<sup>a</sup>  
 Eliakim . . . . . 929<sup>a</sup> (S. F. Hunter)  
   of Jakim . . . . . 1559<sup>b</sup>  
   of Shebna . . . . . 2753<sup>b</sup> (Roberts)  
 Eliali . . . . . 929<sup>a</sup>  
 Eliam . . . . . 929<sup>a</sup>  
 Eliaonias . . . . . 929<sup>a</sup>  
 Elias (Elijah) . . . . . 930<sup>b</sup> (Farr)  
 Eliasaph . . . . . 929<sup>a</sup>  
 Eliashib . . . . . 929<sup>a</sup> (Farr)  
 Eliasib (Eliashib) . . . . . 929<sup>a</sup> (Farr)  
 Eliasibus . . . . . 929<sup>b</sup>  
 Ehasimus . . . . . 929<sup>b</sup>  
 ElIASIS . . . . . 929<sup>b</sup>  
 Eliathah . . . . . 929<sup>b</sup>  
 Elidad . . . . . 929<sup>b</sup>  
   of Eldad . . . . . 923<sup>b</sup>  
 Eliehoenai . . . . . 929<sup>b</sup>  
 Eiel . . . . . 929<sup>b</sup>  
 Elienai . . . . . 929<sup>b</sup>  
 Eliezer . . . . . 929<sup>b</sup> (S. F. Hunter)  
 Elihaba (Elijahba) . . . . . 929<sup>b</sup>  
 Elihoenai (Eliehoenai) . . . . . 929<sup>b</sup>  
 Elihoreph . . . . . 930<sup>a</sup>  
 Elihu . . . . . 930<sup>a</sup>  
   In Book of Job . . . . . 930<sup>a</sup> (Genung)  
   of Job, Book of . . . . . 1684<sup>b</sup> (Genung)  
 Elihu (general) . . . . . 930<sup>a</sup>  
 Elijah . . . . . 930<sup>b</sup> (Farr)  
   Character of prophet . . . . . 932<sup>b</sup>  
   of Israel, Religion of . . . . . 1538<sup>a</sup> (Orelli)  
   of Jezebel . . . . . 1675<sup>b</sup> (Roberts)  
   Miracles in Elijah narratives . . . . . 933<sup>a</sup>  
   In NT . . . . . 933<sup>a</sup>  
   of Palestine . . . . . 2217<sup>a</sup> (Conder)  
   of Prophecy . . . . . 2459<sup>b</sup> (Orelli)  
   of Raven . . . . . 2533<sup>a</sup> (Stratton-Porter)  
   Works of . . . . . 930<sup>b</sup>  
 Elika . . . . . 933<sup>b</sup>  
 Elim . . . . . 933<sup>b</sup>  
 Elimelech . . . . . 933<sup>b</sup> (Reeve)  
   of Naomi . . . . . 2118<sup>a</sup> (Roberts)  
   of Ruth . . . . . 2627<sup>b</sup> (Geden)  
 Elieonai (Eliehoenai) . . . . . 929<sup>b</sup>  
 Elionas . . . . . 933<sup>b</sup>  
 Eliphai . . . . . 933<sup>b</sup>  
 Eliphalat . . . . . 934<sup>a</sup>  
 Eliphaz . . . . . 934<sup>a</sup>  
   In Book of Job . . . . . 934<sup>a</sup> (Genung)  
 Eliphelehu . . . . . 934<sup>a</sup>  
 Eliphelet (Eliphalat) . . . . . 934<sup>a</sup>  
 Elisabeth . . . . . 934<sup>a</sup>  
   of Zacharias . . . . . 3129<sup>b</sup> (Easton)  
 Eliseus  
   of Elisha . . . . . 934<sup>b</sup> (Reeve)

- Elisha . . . . . 934<sup>b</sup> (Reeve)  
 And Benhadad II. . . . . 437<sup>a</sup> (Nicol)  
 Call . . . . . 934<sup>b</sup>  
 Career . . . . . 935<sup>a</sup>  
 Character . . . . . 937<sup>b</sup>  
 Compared with Elijah 937<sup>a</sup>  
 of Gehazi . . . . . 1182<sup>a</sup> (Crichton)  
 of Jehoahaz . . . . . 1575<sup>a</sup> (Caldecott)  
 of Jehu . . . . . 1585<sup>a</sup> (Caldecott)  
 of Joash . . . . . 1576<sup>b</sup> (Caldecott)  
 of Palestine . . . . . 2217<sup>b</sup> (Conder)  
 Parting gift of Elijah. 935<sup>a</sup>  
 Preparation . . . . . 934<sup>b</sup>  
 Elishah . . . . . 937<sup>b</sup> (Grant)  
 Elishama . . . . . 937<sup>b</sup> (Farr)  
 Elishaphat . . . . . 937<sup>b</sup>  
 Elisheba . . . . . 937<sup>b</sup>  
 Elishua . . . . . 938<sup>a</sup>  
 Elisimus (Eliasimus) . . . . . 938<sup>a</sup>  
 Eliu . . . . . 938<sup>a</sup>  
 Eliud . . . . . 938<sup>a</sup>  
 Elizaphan . . . . . 938<sup>a</sup> (Betteridge)  
 Elizur . . . . . 938<sup>a</sup>  
 Elkanah . . . . . 938<sup>a</sup> (Farr)  
 Elkiah . . . . . 938<sup>a</sup>  
 Elkoshite . . . . . 938<sup>a</sup> (Betteridge)  
 Ellasar . . . . . 938<sup>b</sup> (Pinches)  
 Elm . . . . . 938<sup>b</sup>  
 of Terebinth . . . . . 2949<sup>a</sup> (Masterman)  
 Elmadam . . . . . 938<sup>b</sup>  
 Elnaam . . . . . 939<sup>a</sup>  
 Elnathan . . . . . 939<sup>a</sup> (Farr)  
 Elohim, Eloi  
 of God, Names of. . . . . 1265<sup>b</sup> (Mack)  
 Eloi, Eloi, Lama Sabach-  
 thani . . . . . 939<sup>a</sup> (Clippinger)  
 Elon (person) . . . . . 939<sup>a</sup>  
 Elon (place) . . . . . 939<sup>a</sup>  
 Elon-beth-hanan (Elon) 939<sup>a</sup>  
 Elonites  
 of Elon . . . . . 939<sup>a</sup>  
 Eloquent . . . . . 939<sup>b</sup>  
 Eloth (Elath) . . . . . 923<sup>a</sup> (Ewing)  
 Elpaal . . . . . 939<sup>b</sup>  
 Elpalet . . . . . 939<sup>b</sup>  
 of Eliphalat . . . . . 934<sup>a</sup>  
 El-paran . . . . . 2247<sup>a</sup> (Ewing)  
 Elpelet (Eliphelet) . . . . . 934<sup>a</sup>  
 El Roi  
 of God, Names of. . . . . 1264<sup>b</sup> (Mack)  
 El Shaddai  
 of God, Names of. . . . . 1264<sup>b</sup> (Mack)  
 Elteke, Eltekeh . . . . . 939<sup>b</sup> (Ewing)  
 Eltekon . . . . . 939<sup>b</sup>  
 Eltolad . . . . . 939<sup>b</sup>  
 Elul . . . . . 939<sup>b</sup>  
 of Time . . . . . 2981<sup>b</sup> (Porter)  
 Eluzai . . . . . 939<sup>b</sup>  
 Elymaeans (Elamites) . . . . . 917<sup>a</sup> (Pinches)  
 Elymais . . . . . 939<sup>b</sup>  
 Elymas . . . . . 940<sup>a</sup>  
 of Bar-Jesus . . . . . 404<sup>b</sup> (S. F. Hunter)
- Elyon  
 of God, Names of. . . . . 1264<sup>b</sup> (Mack)  
 Elzabad . . . . . 940<sup>a</sup>  
 Elzaphan (Elizaphan) . . . . . 938<sup>a</sup> (Betteridge)  
 Emadabun . . . . . 940<sup>a</sup>  
 Ematheis . . . . . 940<sup>a</sup>  
 Embalming . . . . . 940<sup>a</sup>  
 of Burial . . . . . 529<sup>a</sup> (Eager)  
 Embrace . . . . . 940<sup>a</sup>  
 Embroidery . . . . . 940<sup>a</sup> (Patch)  
 of Crafts . . . . . 734<sup>a</sup> (Patch)  
 Emek-keziz . . . . . 940<sup>b</sup>  
 Emerald  
 of Stones, Precious. . . . . 2856<sup>a</sup> (Fletcher)  
 Emerods . . . . . 940<sup>b</sup> (Macalister)  
 of Plague . . . . . 2402<sup>b</sup> (Macalister)  
 Emim . . . . . 940<sup>b</sup> (Sayce)  
 Eminent . . . . . 941<sup>a</sup>  
 Emmanuel (Immanuel) . . . . . 1457<sup>b</sup> (A. W. Evans)  
 Emmaus . . . . . 941<sup>a</sup> (Masterman)  
 Of the Apocrypha . . . . . 941<sup>a</sup>  
 of Jesus Christ . . . . . 1665<sup>b</sup> (Orr)  
 Of St. Luke . . . . . 941<sup>a</sup>  
 Emmer . . . . . 941<sup>a</sup>  
 Emmeruth . . . . . 941<sup>a</sup>  
 Emmor . . . . . 941<sup>b</sup>  
 Emotion  
 of Passion . . . . . 2255<sup>b</sup> (Easton)  
 Emperor . . . . . 941<sup>b</sup>  
 of Augustus . . . . . 332<sup>a</sup> (Hutchison)  
 of Caesar . . . . . 536<sup>a</sup>  
 Empty . . . . . 941<sup>b</sup> (W. L. Walker)  
 Emulation . . . . . 941<sup>b</sup> (W. L. Walker)  
 En- . . . . . 941<sup>b</sup>  
 of Fountain . . . . . 1141<sup>b</sup> (Day)  
 of Well . . . . . 3081<sup>a</sup> (Day)  
 Enable . . . . . 941<sup>b</sup>  
 Enaim, Enam . . . . . 941<sup>b</sup> (Masterman)  
 of Open Place . . . . . 2196<sup>b</sup> (Easton)  
 Enan . . . . . 942<sup>a</sup>  
 Enasibus . . . . . 942<sup>a</sup>  
 Encampment  
 By the Red Sea . . . . . 942<sup>a</sup>  
 of Wanderings of  
 Israel . . . . . 3064<sup>a</sup> (Conder)  
 of War . . . . . 3069<sup>b</sup> (Nicol)  
 Enchantment . . . . . 942<sup>a</sup> (Pratt)  
 of Astrology . . . . . 295<sup>b</sup> (Maunder)  
 of Divination . . . . . 860<sup>a</sup> (T. W. Davies)  
 of Orator . . . . . 2199<sup>a</sup> (Edwards)  
 End . . . . . 943<sup>a</sup> (W. L. Walker)  
 of Astronomy . . . . . 315<sup>a</sup> (Maunder)  
 End of the World  
 of Eschatology of the  
 NT . . . . . 979<sup>b</sup> (Vos)  
 Endamage . . . . . 943<sup>b</sup>  
 Endeavor . . . . . 943<sup>b</sup>  
 Endrons . . . . . 943<sup>b</sup>  
 Endless . . . . . 943<sup>b</sup> (Orr)  
 En-dor . . . . . 943<sup>b</sup> (Ewing)  
 Witch of . . . . . 944<sup>a</sup> (Orr); 3097<sup>a</sup> (T. W. Davies)



- Endow, Endue . . . . . 944<sup>a</sup> (Farr)  
 Ends of the Earth  
   of Astronomy . . . . . 315<sup>a</sup> (Maunder)  
 Endure . . . . . 944<sup>b</sup>  
 En-eglaim . . . . . 944<sup>b</sup>  
   of Fountain . . . . . 1141<sup>b</sup> (Day)  
 Enemessar . . . . . 944<sup>b</sup> (Hutchison)  
 Enemy . . . . . 944<sup>b</sup> (W. L. Walker)  
 Eneneus . . . . . 945<sup>a</sup>  
 Enflame (Inflame) . . . . . 1468<sup>a</sup>  
 En-gaddi . . . . . 945<sup>a</sup>  
 Engage . . . . . 945<sup>a</sup>  
 En-gannim . . . . . 945<sup>a</sup> (Ewing)  
   of Garden House . . . . . 1175<sup>a</sup>  
 En-gedi . . . . . 945<sup>a</sup> (Wright)  
   of Fountain . . . . . 1141<sup>b</sup> (Day)  
 Engine . . . . . 945<sup>b</sup>  
   of Siege . . . . . 2786<sup>a</sup> (Nicol)  
 English Versions . . . . . 945<sup>b</sup> (Hutchison)  
   of American Revised  
     Version . . . . . 116<sup>a</sup> (Easton)  
 Engraft (Graft) . . . . . 1292<sup>b</sup> (Patch)  
 Engraving  
   of Carving . . . . . 581<sup>b</sup> (Patch)  
   of Crafts . . . . . 734<sup>a</sup> (Patch)  
 En-haddah . . . . . 952<sup>a</sup>  
 Enhakkore . . . . . 952<sup>b</sup>  
 En-hazor . . . . . 952<sup>b</sup>  
 Enigma  
   of Games . . . . . 1168<sup>b</sup> (Smith)  
 Enjoin . . . . . 952<sup>b</sup>  
 Enlarge . . . . . 952<sup>b</sup> (Breslich)  
 Enlargement . . . . . 952<sup>b</sup> (Breslich)  
 Enlighten . . . . . 952<sup>b</sup> (M. O. Evans)  
 Enlil . . . . . 370<sup>b</sup> (Rogers)  
 En-mishpat  
   of Kadesh-barnea . . . . . 1788<sup>b</sup>  
 Enmity . . . . . 952<sup>b</sup> (W. L. Walker)  
   of Abolish . . . . . 15<sup>a</sup> (M. O. Evans)  
   of Hate . . . . . 1343<sup>b</sup> (Orr)  
 Ennatan . . . . . 953<sup>a</sup>  
 Enoch (Enoch) . . . . . 1374<sup>b</sup>  
 Enoch (person) . . . . . 953<sup>a</sup> (Grant)  
   of Apocalyptic Literature . . . . . 161<sup>b</sup> (J. E. H. Thomson)  
 Enoch (place) . . . . . 953<sup>a</sup> (Orr)  
 Enoch, Books of . . . . . 164<sup>b</sup> (J. E. H. Thomson)  
   Date . . . . . 165<sup>b</sup>  
   Ethiopic, Book of . . . . . 164<sup>b</sup> (J. E. H. Thomson)  
   External chronology . . . . . 166<sup>a</sup>  
   History . . . . . 164<sup>b</sup>  
   Language . . . . . 165<sup>a</sup>  
   Quoted in Ep. of Jude 1771<sup>b</sup> (Moorehead)  
   Secrets, Book of . . . . . 164<sup>b</sup> (J. E. H. Thomson)  
   Secrets of Enoch . . . . . 166<sup>b</sup>  
   Slavonic, Book of . . . . . 164<sup>b</sup> (J. E. H. Thomson)  
   Slavonic Enoch . . . . . 166<sup>b</sup>  
 Enormity . . . . . 953<sup>a</sup>  
 Enos . . . . . 953<sup>a</sup> (S. F. Hunter)  
 Enosh . . . . . 140<sup>b</sup> (Davis)  
 Enquire . . . . . 953<sup>b</sup>  
   of Inquire . . . . . 1472<sup>b</sup> (M. O. Evans)  
 En-rimmon . . . . . 953<sup>b</sup> (Masterman)  
   of Rimmon (place) . . . . . 2593<sup>b</sup> (Masterman)  
 En-rogel . . . . . 953<sup>b</sup> (Masterman)  
   of Fountain . . . . . 1141<sup>b</sup> (Day)  
 Enrolment  
   of Chronology of NT . . . . . 645<sup>a</sup> (Armstrong)  
   of Tax . . . . . 2918<sup>a</sup> (Sweet)  
 Ensample  
   of Example . . . . . 1050<sup>a</sup>  
 En-shemesh . . . . . 954<sup>b</sup>  
 Ensign  
   of Banner . . . . . 384<sup>a</sup> (Eager)  
 Ensnare . . . . . 954<sup>b</sup>  
 Entangle . . . . . 954<sup>b</sup> (Pratt)  
 En-tappuah . . . . . 954<sup>b</sup>  
 Entreat . . . . . 1490<sup>b</sup> (Miller)  
 Environment  
   of Sin . . . . . 2800<sup>b</sup> (McConnell)  
 Envy . . . . . 955<sup>a</sup> (W. L. Walker)  
 Epaeetus . . . . . 955<sup>a</sup> (S. F. Hunter)  
 Epaphras . . . . . 955<sup>a</sup> (S. F. Hunter)  
 Epaphroditus . . . . . 955<sup>b</sup> (S. F. Hunter)  
 Ephah (measure) . . . . . 955<sup>b</sup>  
   of Weights and Measures . . . . . 3079<sup>a</sup> (Porter)  
 Ephah (person) . . . . . 955<sup>b</sup> (Williams)  
 Ephai . . . . . 955<sup>b</sup>  
 Epher . . . . . 955<sup>b</sup>  
 Ephes-dammim . . . . . 956<sup>a</sup> (Masterman)  
 Ephesian . . . . . 956<sup>a</sup>  
 Ephesians, Epistle to the . . . . . 956<sup>a</sup> (C. S. Lewis)  
   Argument . . . . . 960<sup>a</sup>  
   Authenticity . . . . . 956<sup>a</sup>  
   Destination . . . . . 957<sup>b</sup>  
   of Laodiceans, Ep. to . . . . . 1837<sup>b</sup> (Rutherford)  
   Place and date . . . . . 957<sup>b</sup>  
   Purpose . . . . . 959<sup>b</sup>  
   Relation to other NT  
     writings . . . . . 958<sup>b</sup>  
     Teaching . . . . . 960<sup>a</sup>  
 Ephesus . . . . . 961<sup>a</sup> (Banks)  
   of Samos . . . . . 2674<sup>b</sup> (Kinsella)  
   of Timothy . . . . . 2985<sup>a</sup> (Rutherford)  
   of Town Clerk . . . . . 3001<sup>a</sup> (Dosker)  
 Ephlal . . . . . 962<sup>a</sup>  
 Ephod (person) . . . . . 962<sup>b</sup>; 8<sup>a</sup> (Beecher)  
 Ephod (vestment) . . . . . 962<sup>a</sup> (Sampey)  
   of Images . . . . . 1452<sup>a</sup> (Cobern)  
   of Priests and Levites . . . . . 2452<sup>a</sup> (Wiener)  
 Ephphatha . . . . . 962<sup>b</sup>  
 Ephraim  
   of Hill, Hill Country . . . . . 1392<sup>a</sup> (Masterman)  
 Ephraim (person and  
   tribe) . . . . . 963<sup>a</sup> (Ewing)  
 Ephraim (town) . . . . . 963<sup>b</sup> (Ewing)  
 Ephraim, Forest (Wood) of . . . . . 963<sup>b</sup>  
 Ephraim, Gate of  
   of Jerusalem . . . . . 1603<sup>a</sup> (Masterman)  
 Ephraim, Mount . . . . . 963<sup>b</sup>  
   of Gaash . . . . . 1150<sup>a</sup>  
 Ephraimite . . . . . 963<sup>b</sup>  
   of Ephrath . . . . . 964<sup>a</sup> (Masterman)

- Ephraim (Ephron) . . . . .964<sup>a</sup> (Masterman)  
 Ephrath, Ephrathah . . . . .964<sup>a</sup> (Masterman)  
 Ephrathite . . . . .964<sup>a</sup> (Masterman)  
 Ephron (person) . . . . .964<sup>a</sup>  
   of Money . . . . .2076<sup>a</sup> (Porter)  
 Ephron (place) . . . . .964<sup>a</sup> (Masterman)  
   of Gephyrun . . . . .1217<sup>a</sup>  
 Epicureans . . . . .964<sup>a</sup> (Rees)  
   Antithesis of Paul's  
     teaching . . . . .965<sup>b</sup>  
   Ataraxy . . . . .965<sup>a</sup>  
   Atomic theory . . . . .965<sup>a</sup>  
   Causes of success . . . . .965<sup>b</sup>  
   "Consensus Gentium" . . . . .965<sup>b</sup>  
   Egoistic hedonism . . . . .964<sup>b</sup>  
   Epicurean gods . . . . .965<sup>b</sup>  
   Materialism . . . . .965<sup>b</sup>  
   Social contract . . . . .965<sup>a</sup>  
   Social and political  
     causes . . . . .964<sup>a</sup>  
   of Stoics . . . . .2854<sup>b</sup> (Rees)  
   Theory of ideas . . . . .965<sup>b</sup>  
 Epilepsy  
   of Lunatic . . . . .1941<sup>b</sup> (Sweet)  
 Epiphanes  
   of Antiochus IV . . . . .159<sup>b</sup> (Harry)  
 Epiphanius . . . . .1000<sup>b</sup> (J. E. H. Thomson)  
 Epiphi . . . . .966<sup>a</sup>  
   of Year . . . . .3126<sup>a</sup>  
 Epistle . . . . .966<sup>a</sup> (Pratt)  
   Apocryphal . . . . .967<sup>b</sup>  
   Distinctive character-  
     istics . . . . .966<sup>a</sup>  
   Distinguished from a  
     letter . . . . .967<sup>b</sup>  
   Epistolary writings in  
     NT . . . . .967<sup>a</sup>  
   Letters in Apocrypha . . . . .967<sup>a</sup>  
   Letter-writing in an-  
     tiquity . . . . .966<sup>b</sup>  
   NT epistles . . . . .966<sup>a</sup>  
   OT epistles . . . . .966<sup>b</sup>  
   Patristic epistles . . . . .967<sup>b</sup>  
 Epistles, Captivity  
   of Philemon, Ep. to . . . . .2366<sup>b</sup> (C. S. Lewis)  
 Epistles, The Pastoral . . . . .2258<sup>b</sup> (Rutherford)  
 Epistles, Spurious  
   of Apocryphal Epistles . . . . .194<sup>b</sup> (J. M. Wilson)  
 Equal . . . . .968<sup>a</sup> (Jacobs)  
 Equality . . . . .968<sup>a</sup> (Jacobs)  
 Equity . . . . .968<sup>a</sup> (M. O. Evans)  
 Er . . . . .968<sup>a</sup>  
 Era . . . . .968<sup>b</sup> (Porter)  
   of Time . . . . .2982<sup>b</sup> (Porter)  
 Eran . . . . .968<sup>b</sup>  
 Eranites . . . . .968<sup>b</sup>  
 Erastus . . . . .969<sup>a</sup> (S. F. Hunter)  
 Erech . . . . .969<sup>a</sup> (Pinches); 365<sup>a</sup>  
   (Clay)  
 Eri, Erites . . . . .969<sup>b</sup>  
 Eri-aku . . . . .969<sup>b</sup> (Pinches)  
   of Tidal . . . . .2980<sup>a</sup> (Pinches)  
 Err . . . . .970<sup>b</sup> (W. L. Walker)  
 Error . . . . .970<sup>b</sup> (W. L. Walker)  
 Esaias  
   of Isaiah . . . . .1495<sup>b</sup> (Robinson)  
 Esarhaddon . . . . .971<sup>a</sup> (Clay); 271<sup>b</sup> (Clay);  
   294<sup>b</sup> (Sayce); 367<sup>a</sup>  
   (Clay)  
   of Sarchedonus . . . . .2692<sup>a</sup>  
 Esau . . . . .971<sup>b</sup> (Forrester)  
   of Birthright . . . . .478<sup>a</sup> (J. M. Wilson)  
   of Family of, in Genesis 1208<sup>b</sup> (Möller)  
   of Jacob . . . . .1550<sup>a</sup> (Boyd)  
 Essay . . . . .972<sup>a</sup>  
 Eschatology, NT . . . . .979<sup>b</sup> (Vos)  
   Consummate state . . . . .991<sup>a</sup>  
   Development . . . . .980<sup>b</sup>  
   Doctrinal and religious  
     significance . . . . .979<sup>b</sup>  
   of Gehenna . . . . .1183<sup>a</sup> (Vos)  
   General and individual . . . . .981<sup>a</sup>  
   General structure . . . . .980<sup>a</sup>  
   of Hades . . . . .1315<sup>b</sup> (Vos)  
   of Heavens, New . . . . .1353<sup>a</sup> (Vos)  
   of Hope . . . . .1419<sup>b</sup> (Easton)  
   Intermediate state . . . . .991<sup>b</sup>  
   Jesus' discourse . . . . .1657<sup>b</sup> (Orr)  
   of Johannine Theology 1705<sup>a</sup> (Law)  
   Judgment . . . . .989<sup>b</sup>  
     of Judgment, Last . . . . .1777<sup>b</sup> (Easton)  
   of Last Time . . . . .1840<sup>a</sup> (Vos)  
   of Mark, Gospel of . . . . .1994<sup>b</sup> (Farmer)  
   of Paradise . . . . .2246<sup>a</sup> (Wright)  
   Parousia . . . . .981<sup>b</sup>; 2249<sup>a</sup> (Easton)  
   of Prison, Spirits in . . . . .2456<sup>b</sup> (Orr)  
   of Punishment, Ever-  
     lasting . . . . .2503<sup>b</sup> (Orr)  
   of Regeneration . . . . .2546<sup>b</sup> (Nuelsen)  
   Resurrection . . . . .986<sup>a</sup>  
   of Sirach, Book of . . . . .2808<sup>b</sup> (T. W. Davies)  
 Eschatology, OT . . . . .972<sup>a</sup> (Orr)  
   of Abraham's Bosom . . . . .22<sup>b</sup> (Orr)  
   Apocalyptic . . . . .978<sup>a</sup>  
   Apocryphal . . . . .978<sup>a</sup>  
   Conceptions of future  
     life . . . . .973<sup>b</sup>  
   Fundamental ideas . . . . .972<sup>b</sup>  
   of Hell . . . . .1371<sup>a</sup> (Orr)  
   Idea of judgment . . . . .977<sup>a</sup>  
   of Immortal . . . . .1460<sup>a</sup> (Orr)  
   of Jesus Christ . . . . .1630<sup>a</sup> (Orr)  
   Later Jewish concep-  
     tions . . . . .978<sup>a</sup>  
   Life and resurrection . . . . .974<sup>b</sup>  
   of Messiah . . . . .2042<sup>b</sup> (Crichton)  
   of Paradise . . . . .2246<sup>a</sup> (Wright)  
   of Punishment, Ever-  
     lasting . . . . .2501<sup>b</sup> (Orr)  
   of Resurrection . . . . .2565<sup>a</sup> (Easton)  
   of Sheol . . . . .2761<sup>a</sup> (Orr)  
   of Zephaniah, Book of 3146<sup>a</sup> (Eiselen)  
 Eschew . . . . .993<sup>a</sup>

- Esdraclon, Plain of . . . . . 993<sup>a</sup> (Ewing)  
 of Harod, Well of . . . . . 1340<sup>b</sup> (Ewing)
- Esdras (Apocalyptic) . . . . . 996<sup>a</sup> (T. W. Davies)  
 Contents . . . . . 996<sup>a</sup>  
 Date . . . . . 996<sup>b</sup>  
 Name . . . . . 996<sup>a</sup>  
 Origin of the book . . . . . 996<sup>b</sup>  
 Original language . . . . . 996<sup>a</sup>  
 Versions . . . . . 996<sup>b</sup>
- Esdras, Fifth and Sixth . . . . . 996<sup>b</sup>
- Esdras, First Book of . . . . . 994<sup>a</sup> (T. W. Davies)  
 Contents . . . . . 994<sup>b</sup>  
 Date and authorship . . . . . 995<sup>b</sup>  
 Name . . . . . 994<sup>a</sup>  
 Versions . . . . . 995<sup>b</sup>
- Esdras, Fourth Book of . . . . . 172<sup>a</sup> (J. E. H. Thomson)
- Esdras, Second Book of  
 of Apocalyptic Literature . . . . . 161<sup>b</sup> (J. E. H. Thomson)
- Esdris . . . . . 996<sup>b</sup>
- Esebon . . . . . 996<sup>b</sup>
- Esebias  
 of Eserebias . . . . . 997<sup>a</sup>  
 of Sherebiah . . . . . 276<sup>4b</sup> (Wolf)
- Esek . . . . . 997<sup>a</sup>
- Eserebias . . . . . 997<sup>a</sup>
- Eshan . . . . . 997<sup>a</sup>
- Eshbaal  
 of Ish . . . . . 1508<sup>b</sup>  
 of Ishbosheth . . . . . 1508<sup>b</sup> (Breslich)
- Eshban . . . . . 997<sup>a</sup>  
 of Ish . . . . . 1508<sup>b</sup>
- Eshcol (person) . . . . . 997<sup>a</sup>
- Eshcol (place) . . . . . 997<sup>a</sup> (Masterman)
- Eshean (Eshan) . . . . . 997<sup>a</sup>
- Eshek . . . . . 997<sup>a</sup>
- Eshkalonite (Askelon) . . . . . 282<sup>b</sup>
- Eshtaol . . . . . 997<sup>a</sup> (Ewing)
- Eshtaolites . . . . . 997<sup>a</sup>
- Eshtemoa, Eshtemoh . . . . . 997<sup>a</sup>
- Eshton . . . . . 997<sup>b</sup>
- Esli . . . . . 997<sup>b</sup>
- Esora (Aesora) . . . . . 65<sup>b</sup>
- Espousal, Espouse . . . . . 997<sup>b</sup>  
 of Spouse . . . . . 2846<sup>b</sup>
- Espy . . . . . 997<sup>b</sup>
- Esril (Ezril) . . . . . 1085<sup>b</sup>
- Esrom . . . . . 997<sup>b</sup>
- Essenes, The . . . . . 997<sup>b</sup> (J. E. H. Thomson)  
 of Abstinence . . . . . 25<sup>a</sup> (Eager)  
 And Christianity . . . . . 1004<sup>b</sup>  
 of Ebionism . . . . . 890<sup>b</sup> (J. E. H. Thomson)
- Deductions and combinations . . . . . 1001<sup>a</sup>  
 History and origin . . . . . 1001<sup>b</sup>  
 of Josephus Flavius . . . . . 1742<sup>a</sup> (Wenley)  
 Name . . . . . 998<sup>b</sup>  
 Relation to apocalyptic books . . . . . 1003<sup>b</sup>  
 Sources of information . . . . . 998<sup>a</sup>
- Estate . . . . . 1005<sup>b</sup>
- Esteem . . . . . 1005<sup>b</sup> (W. L. Walker)
- Esther (Hadassah) . . . . . 1314<sup>b</sup>  
 of Myrtle . . . . . 2103<sup>b</sup> (Masterman)
- Esther, Book of . . . . . 1006<sup>a</sup> (Urquhart)  
 Attacks upon . . . . . 1007<sup>b</sup>  
 Authorship . . . . . 1006<sup>b</sup>  
 Canonicity . . . . . 1006<sup>b</sup>  
 Confirmations of . . . . . 1008<sup>b</sup>  
 Contents . . . . . 1007<sup>a</sup>  
 Date . . . . . 1006<sup>b</sup>  
 Greek additions . . . . . 1007<sup>b</sup>  
 Objections . . . . . 1008<sup>a</sup>  
 of Tobit, Book of . . . . . 2990<sup>b</sup> (T. W. Davies)
- Esther, The Rest of . . . . . 1009<sup>b</sup> (T. W. Davies)  
 Contents . . . . . 1009<sup>b</sup>  
 Date . . . . . 1010<sup>a</sup>  
 of Lysimachus . . . . . 1944<sup>a</sup> (Hutchison)  
 Name . . . . . 1009<sup>b</sup>  
 Original language . . . . . 1010<sup>a</sup>
- Estimate, Estimation . . . . . 1010<sup>a</sup>
- Esyelus . . . . . 1010<sup>a</sup>
- Etam . . . . . 1010<sup>a</sup> (Masterman)  
 of Nephtoah . . . . . 2134<sup>a</sup> (Masterman)
- Eternal . . . . . 1010<sup>b</sup> (J. Lindsay)
- Eternal Life  
 of Johannine Theology 1702<sup>b</sup> (Law)
- Eternity . . . . . 1011<sup>a</sup> (J. Lindsay)
- Etham . . . . . 1012<sup>b</sup> (Conder)  
 of Goshen . . . . . 1280<sup>a</sup> (Conder)  
 of Migdol . . . . . 2050<sup>b</sup> (Conder)  
 of Pithom . . . . . 2401<sup>b</sup> (Conder)  
 of Succoth . . . . . 2869<sup>a</sup> (Conder)
- Ethan . . . . . 1012<sup>b</sup>
- Ethanim . . . . . 1012<sup>b</sup>  
 of Calendar . . . . . 541<sup>b</sup> (Porter)  
 of Time . . . . . 2981<sup>b</sup> (Porter)
- Ethanas . . . . . 1012<sup>b</sup>
- Ethbaal . . . . . 1012<sup>b</sup>
- Ether . . . . . 1013<sup>a</sup>
- Ethics . . . . . 1013<sup>a</sup> (Alexander)  
 English moralists . . . . . 1019<sup>a</sup>  
 Evolutionary ethics . . . . . 1019<sup>b</sup>  
 German idealists . . . . . 1019<sup>b</sup>  
 Greek philosophy . . . . . 1017<sup>a</sup>  
 Kant . . . . . 1019<sup>b</sup>  
 Nature and function of . . . . . 1013<sup>b</sup>  
 Of NT . . . . . 1022<sup>b</sup>  
 Duties . . . . . 1024<sup>b</sup>  
 Virtues . . . . . 1024<sup>a</sup>  
 Of OT and Apocrypha . . . . . 1020<sup>a</sup>  
 Reformation . . . . . 1019<sup>a</sup>  
 Scholasticism . . . . . 1018<sup>b</sup>  
 of Sermon on the Mount . . . . . 2732<sup>b</sup> (Miller)  
 of Sin . . . . . 2798<sup>b</sup> (McConnell)  
 of Trade . . . . . 3002<sup>a</sup> (Easton)  
 of Truth . . . . . 3025<sup>a</sup> (Carver)  
 Utilitarianism . . . . . 1019<sup>a</sup>
- Ethics of Jesus . . . . . 1026<sup>a</sup> (Stalker)  
 In the Fourth Gospel . . . . . 1030<sup>a</sup>  
 Eternal life . . . . . 1030<sup>a</sup>  
 Fruits of union with Christ . . . . . 1030<sup>b</sup>

Ethics of Jesus—*continued*

- In the Fourth Gospel—*continued*  
 Nature of faith . . . . . 1030<sup>b</sup>  
 Need of new birth . . . . . 1030<sup>b</sup>  
 of Jesus Christ . . . . . 1642<sup>b</sup> (Orr)  
 of Lord's Day . . . . . 1919<sup>a</sup> (Easton)  
 of Sabbath . . . . . 2631<sup>b</sup> (Sampey)  
 of Sermon on the  
 Mount . . . . . 2732<sup>b</sup> (Miller)  
 of Sin . . . . . 2800<sup>a</sup> (McConnell)  
 In Synoptic Gospels . . . . . 1026<sup>a</sup>  
 Blessings of the  
 kingdom . . . . . 1026<sup>a</sup>  
 Character of sub-  
 jects of kingdom . . . . . 1027<sup>b</sup>  
 Commandments of  
 the King . . . . . 1029<sup>a</sup>
- Ethiopia . . . . . 1031<sup>a</sup> (Cobern)  
 of Africa . . . . . 68<sup>a</sup> (Pinches)  
 Bible references . . . . . 1032<sup>b</sup>  
 Exploration . . . . . 1034<sup>b</sup>  
 Geography . . . . . 1031<sup>a</sup>  
 History . . . . . 1031<sup>b</sup>  
 Literature . . . . . 1034<sup>a</sup>  
 Religion . . . . . 1033<sup>a</sup>
- Ethiopian Eunuch . . . . . 1034<sup>b</sup> (Kerr)  
 of Philip, the Evangel-  
 ist . . . . . 2368<sup>b</sup> (S. F. Hunter)
- Ethiopian Woman  
 of Cushite Woman . . . . . 769<sup>a</sup> (Boyd)
- Ethiopic Language . . . . . 1035<sup>a</sup> (Littman)
- Ethiopic Versions . . . . . 1036<sup>a</sup> (Weir)
- Eth-kasin . . . . . 1036<sup>b</sup>
- Ethma (Nooma) . . . . . 2155<sup>a</sup>
- Ethnan . . . . . 1036<sup>b</sup>
- Ethnarch  
 of Governor . . . . . 1289<sup>b</sup> (Heidel)
- Ethni . . . . . 1036<sup>b</sup>
- Ethnography, Ethnology  
 of Table of Nations . . . . . 2898<sup>b</sup> (Pinches)
- Eubulus . . . . . 1036<sup>b</sup> (Rutherford)
- Eucharist  
 of Jesus Christ . . . . . 1658<sup>b</sup> (Orr)  
 of Lord's Supper . . . . . 1921<sup>b</sup> (Gumme; Dosker;  
 Dau; Kurtz)
- Eumenes II . . . . . 1036<sup>b</sup> (Hutchison)
- Eunatan (Ennatan) . . . . . 953<sup>a</sup>
- Eunice . . . . . 1037<sup>a</sup> (Rutherford)  
 of Lois . . . . . 1917<sup>b</sup> (Rutherford)
- Eunuch . . . . . 1037<sup>a</sup> (Eager)  
 of Marriage . . . . . 1996<sup>b</sup> (Eager)  
 of Member . . . . . 2030<sup>a</sup> (Luering)  
 of Polygamy . . . . . 2416<sup>a</sup> (Caverno)  
 of Punishments . . . . . 2506<sup>a</sup> (Hirsch)
- Euodia . . . . . 1038<sup>a</sup> (Rutherford)  
 of Succeed, Success . . . . . 2868<sup>b</sup> (W. L. Walker)  
 of Syntyche . . . . . 2880<sup>a</sup> (Rutherford)  
 of Yokefellow . . . . . 3127<sup>a</sup> (Rutherford)
- Eupator . . . . . 1038<sup>b</sup> (Hutchison)
- Euphrates . . . . . 1038<sup>b</sup> (Wright)
- Eupolemus . . . . . 1039<sup>a</sup> (Hutchison)
- Euraquilo . . . . . 1039<sup>b</sup> (Joy)

## Eusebius

- of Mark, Gospel of . . . . . 1990<sup>a</sup> (Farmer)  
 of Palestine, Recent  
 Exploration . . . . . 2223<sup>b</sup> (Cobern)
- Eutyclus . . . . . 1039<sup>a</sup> (S. F. Hunter)
- Evangelist . . . . . 1039<sup>b</sup> (Gray)
- Eve, Gospel of . . . . . 1040<sup>a</sup>
- Eve in NT . . . . . 1040<sup>b</sup> (Fortune)  
 of Child-bearing . . . . . 607<sup>b</sup> (Jacobs)
- Eve in OT . . . . . 1040<sup>a</sup> (Genung)  
 of Adam in OT and  
 Apoc . . . . . 49<sup>a</sup> (Genung)  
 of Adam in OT (Evo-  
 lutionary Interpreta-  
 tion) . . . . . 51<sup>b</sup> (Genung)  
 of Family . . . . . 1095<sup>a</sup> (Caverno)  
 of Havvah . . . . . 1345<sup>a</sup>  
 of Sin . . . . . 2799<sup>a</sup> (McConnell)
- Even, Evening, Eventide 1041<sup>a</sup> (Porter)
- Evenings, Between the . . . . . 1041<sup>a</sup>
- Event . . . . . 1041<sup>a</sup>
- Everlasting . . . . . 1041<sup>a</sup> (Orr)  
 of Age . . . . . 70<sup>b</sup> (W. L. Walker)  
 of Eternal . . . . . 1010<sup>b</sup> (J. Lindsay)  
 of Eternity . . . . . 1011<sup>a</sup> (J. Lindsay)
- Evi . . . . . 1041<sup>b</sup>
- Evidence, Evident . . . . . 1041<sup>b</sup> (W. L. Walker)
- Evil . . . . . 1041<sup>b</sup> (Dungan)  
 Moral evil . . . . . 1042<sup>a</sup>  
 Physical evil . . . . . 1042<sup>a</sup>
- Evil-doers . . . . . 1042<sup>b</sup>
- Evil Eye . . . . . 1042<sup>b</sup> (Luering)  
 of Envy . . . . . 955<sup>a</sup> (W. L. Walker)  
 of Eye . . . . . 1069<sup>b</sup> (Luering)
- Evil-favoredness . . . . . 1043<sup>a</sup> (Luering)
- Evil-merodach . . . . . 1043<sup>a</sup> (R. D. Wilson);  
 367<sup>b</sup> (Clay)
- Evil One . . . . . 1043<sup>a</sup> (Dungan)  
 of Satan . . . . . 2693<sup>b</sup> (Sweet)
- Evil-speaking . . . . . 1043<sup>a</sup> (W. L. Walker)  
 of Blasphemy . . . . . 485<sup>b</sup> (Rees)  
 of Railing . . . . . 2525<sup>b</sup> (W. L. Walker)  
 of Slander . . . . . 2814<sup>b</sup> (Edwards)
- Evil Spirit  
 of Communion with  
 Demons . . . . . 689<sup>b</sup> (Sweet)  
 of Demon . . . . . 827<sup>b</sup> (Sweet)  
 of Satan . . . . . 2693<sup>b</sup> (Sweet)
- Evil Thing . . . . . 1043<sup>b</sup> (Dungan)
- Evolution . . . . . 1043<sup>b</sup> (Zenos); 148<sup>a</sup> (Ma-  
 rais); 692<sup>a</sup> (Tisdall)  
 And Biblical truth . . . . . 1044<sup>a</sup>  
 Christianity and Chris-  
 tian doctrine . . . . . 1047<sup>a</sup>  
 And creation . . . . . 1044<sup>b</sup>  
 Descent of man . . . . . 1046<sup>a</sup>  
 And the fall . . . . . 1093<sup>a</sup>  
 Idea of . . . . . 1043<sup>b</sup>  
 Moral nature . . . . . 1047<sup>a</sup>  
 Origin and nature of  
 religion . . . . . 1046<sup>b</sup>  
 And origin of species . . . . . 1044<sup>b</sup>  
 Recent origin of notion . . . . . 1044<sup>a</sup>  
 of Regeneration . . . . . 2546<sup>b</sup> (Nuelsen)

- Evolution—*continued*  
 of Virgin-birth . . . . . 3052<sup>a</sup> (Sweet)  
 of World, Cosmo-  
 logical . . . . . 3106<sup>a</sup> (Orr)
- Evolutionary History  
 Archaeological theory. 231<sup>a</sup> (Kyle)
- Ewe . . . . . 1049<sup>a</sup>  
 of Sheep . . . . . 2756<sup>b</sup> (Day)
- Exact . . . . . 1049<sup>a</sup> (Betteridge)
- Exaction . . . . . 1049<sup>b</sup>
- Extractors . . . . . 1049<sup>b</sup>
- Exalt . . . . . 1049<sup>b</sup> (W. L. Walker)
- Exaltation of Christ. . . . . 614<sup>b</sup> (Bevan)
- Examine, Examination. . . . . 1049<sup>b</sup> (Hirsch)  
 of Courts, Judicial. . . . . 725<sup>b</sup> (Hirsch)
- Example . . . . . 1050<sup>a</sup>
- Excavation  
 of Memphis . . . . . 2031<sup>a</sup> (Petrie)  
 of Palestine . . . . . 2212<sup>a</sup> (Conder)  
 of Sherghat . . . . . 2765<sup>a</sup> (Banks)  
 of Tahpanhes . . . . . 2903<sup>a</sup> (Cobern)
- Exceed, Exceeding, Ex-  
 ceedingly . . . . . 1050<sup>a</sup>
- Excellency . . . . . 1050<sup>a</sup> (W. L. Walker)
- Excellent . . . . . 1050<sup>a</sup> (W. L. Walker)
- Exchange, Exchanger  
 of Bank, Banking. . . . . 383<sup>a</sup> (Eager)
- Excommunication . . . . . 1050<sup>b</sup> (Crannell)
- Execute, Execution . . . . . 1051<sup>b</sup> (Eager)
- Exegesis  
 of Interpretation. . . . . 1489<sup>a</sup> (Schodde)
- Exercise . . . . . 1051<sup>b</sup> (W. L. Walker)
- Exhortation . . . . . 1051<sup>b</sup> (W. L. Walker)
- Exile . . . . . 1052<sup>a</sup>  
 of Captivity . . . . . 569<sup>b</sup> (Nicol)  
 of Israel, History of . . . . . 1525<sup>a</sup> (Orelli)  
 of Israel, Religion of. . . . . 1539<sup>b</sup> (Orelli)  
 of Trade . . . . . 3003<sup>b</sup> (Easton)
- Exodus, The . . . . . 1052<sup>a</sup> (Conder); 911<sup>b</sup>  
 (Petrie)  
 Date . . . . . 1053<sup>a</sup>  
 of Goshen . . . . . 1280<sup>a</sup> (Conder)  
 of Israel, History of . . . . . 1515<sup>b</sup> (Orelli)  
 Lepsius' theory. . . . . 1054<sup>b</sup>  
 of Migdol . . . . . 2050<sup>b</sup> (Conder)  
 of Moses . . . . . 2086<sup>a</sup> (Kyle)  
 Numbers . . . . . 1056<sup>a</sup>  
 of Palestine . . . . . 2212<sup>b</sup> (Conder)  
 of Pithom . . . . . 2401<sup>b</sup> (Conder)  
 of Raamses, Rameses. 2520<sup>b</sup> (Conder)  
 of Red Sea . . . . . 2539<sup>b</sup> (Wright)  
 Route . . . . . 1052<sup>a</sup>  
 of Succoth . . . . . 2869<sup>a</sup> (Conder)  
 of Wanderings of Israel 3066<sup>b</sup>; 3069<sup>b</sup> (Conder)
- Exodus, Book of . . . . . 1056<sup>b</sup> (Möller)  
 Authorship . . . . . 1066<sup>a</sup>  
 Connection with other  
 books of Pentateuch 1057<sup>a</sup>  
 Contents, analysis of . . . . . 1058<sup>a</sup>  
 of Genesis . . . . . 1207<sup>a</sup> (Möller)  
 Historical character. . . . . 1064<sup>b</sup>
- Exodus, Book of—*continued*  
 of Leviticus . . . . . 1871<sup>b</sup>; 1878<sup>a</sup> (Möller)  
 Name . . . . . 1056<sup>b</sup>
- Exorcism . . . . . 1067<sup>b</sup> (Sweet)  
 of Zoroastrianism. . . . . 3157<sup>a</sup> (Easton)
- Expect, Expectation. . . . . 1068<sup>b</sup> (Jacobs)
- Expectation, Messianic  
 of Christs, False. . . . . 628<sup>b</sup> (Orr)  
 of Eschatology of OT. 972<sup>a</sup> (Orr)  
 of Jesus Christ . . . . . 1624<sup>a</sup> (Orr)  
 of Messiah . . . . . 2039<sup>a</sup> (Crichton)
- Expedient . . . . . 1068<sup>b</sup> (W. L. Walker)
- Experience . . . . . 1068<sup>b</sup> (Gray)
- Experiment . . . . . 1069<sup>a</sup>
- Expiation . . . . . 1069<sup>a</sup> (Carver)  
 of Atonement . . . . . 627<sup>b</sup> (Orr)  
 of Propitiation . . . . . 2467<sup>a</sup> (Carver)  
 of Sacrifice, OT . . . . . 2638<sup>a</sup> (Reeve)
- Exposure to Wild Beasts  
 of Punishments. . . . . 2504<sup>b</sup> (Hirsch)
- Express . . . . . 1069<sup>a</sup>
- Exquisite . . . . . 1069<sup>a</sup>
- Extinct . . . . . 1069<sup>a</sup>
- Extortion . . . . . 1069<sup>a</sup> (W. Evans)
- Extreme, Extremity. . . . . 1069<sup>b</sup>
- Eye . . . . . 1069<sup>b</sup> (Luering)  
 of Envy . . . . . 955<sup>a</sup> (W. L. Walker)  
 of Evil Eye . . . . . 1042<sup>b</sup> (Luering)
- Eyelid . . . . . 1070<sup>a</sup> (Eager)
- Eyepaint  
 of Color, Colors. . . . . 674<sup>b</sup> (Patch)  
 of Eyelid . . . . . 1070<sup>a</sup> (Eager)  
 of Keren-happuch . . . . . 1793<sup>a</sup>  
 of Paint . . . . . 2208<sup>a</sup> (Crannell)
- Eyesalve . . . . . 1070<sup>a</sup>
- Eyes, Blinding of  
 of Eye . . . . . 1069<sup>b</sup> (Luering)  
 of Punishments. . . . . 2504<sup>b</sup> (Hirsch)
- Eyes, Covering of . . . . . 1070<sup>a</sup>
- Eyes, Diseases of. . . . . 1070<sup>a</sup> (Macalister)  
 of Blindness . . . . . 487<sup>b</sup> (Macalister)
- Eyeservice . . . . . 1070<sup>b</sup>
- Eyes, Tender  
 of Blindness . . . . . 487<sup>b</sup> (Macalister)
- Ear (Ezer) . . . . . 1081<sup>b</sup>
- Ezba . . . . . 1070<sup>b</sup>
- Ezbon . . . . . 1070<sup>b</sup>  
 of Ozni . . . . . 2206<sup>b</sup>
- Ezekias (Ezechias). . . . . 1071<sup>a</sup>
- Ezekiel . . . . . 1071<sup>a</sup> (Möller)  
 of Genesis . . . . . 1202<sup>b</sup> (Möller)  
 of Jehezkel . . . . . 1574<sup>a</sup>  
 of Leviticus . . . . . 1871<sup>b</sup>; 1879<sup>b</sup> (Möller)  
 of Ministry of Ezekiel. 573<sup>a</sup> (Nicol)  
 of Palestine . . . . . 2219<sup>b</sup> (Conder)  
 Prophet and his book. 1071<sup>a</sup>  
 The book . . . . . 1072<sup>a</sup>  
 Person of Ezekiel. . . . . 1071<sup>a</sup>  
 of Sacrifice, OT . . . . . 2648<sup>a</sup> (Reeve)
- Significance of Ezekiel  
 in Israel's religious  
 history . . . . . 1073<sup>b</sup>

- Ezekiel—*continued*  
 Significance of Ezekiel in Israel's religious history  
   —*continued*  
   Ezekiel and apocalyptic literature . . . 1080<sup>a</sup>  
   Ezekiel and Levitical system . . . . . 1074<sup>b</sup>  
   Ezekiel and Messianic ideal . . . . . 1079<sup>b</sup>  
   Ezekiel's conception of God . . . . . 1080<sup>b</sup>  
   Formal characteristics of Ezekiel . . . 1073<sup>b</sup>  
   of Temple of Ezekiel . . . 2934<sup>b</sup> (Caldecott; Orr)  
   of Tile, Tiling . . . . . 2981<sup>b</sup>  
 Ezel . . . . . 1081<sup>b</sup>  
 Ezem . . . . . 1081<sup>b</sup>  
 Ezer . . . . . 1081<sup>b</sup>  
 Ezerias . . . . . 1081<sup>b</sup>  
 Ezias (Ozias) . . . . . 2206<sup>b</sup>  
 Ezion-geber . . . . . 1082<sup>b</sup> (Ewing)  
 Eznite  
   of Adino . . . . . 56<sup>a</sup> (Beecher)  
 Ezora . . . . . 1082<sup>a</sup>  
 Ezra (person) . . . . . 1082<sup>a</sup> (R. D. Wilson)  
   Family . . . . . 1082<sup>a</sup>  
   His commission . . . . . 1082<sup>b</sup>  
   of Israel, History of . . . 1526<sup>b</sup> (Orelli)  
   Occupation . . . . . 1082<sup>b</sup>  
   Reforms and labors of 575<sup>b</sup> (Nicol)  
   Traditions . . . . . 1083<sup>a</sup>  
 Ezra-Nehemiah (Book) . . . 1083<sup>a</sup> (R. D. Wilson)  
   Historicity . . . . . 1084<sup>a</sup>  
   Languages . . . . . 1083<sup>b</sup>  
   Literary character . . . 1083<sup>b</sup>  
   Name . . . . . 1083<sup>a</sup>  
   of Nehemiah . . . . . 2131<sup>a</sup> (R. D. Wilson)  
   Object . . . . . 1083<sup>a</sup>  
   Plan . . . . . 1083<sup>a</sup>  
   Sources . . . . . 1083<sup>b</sup>  
   Text . . . . . 1084<sup>b</sup>  
   Unity . . . . . 1083<sup>a</sup>  
 Ezrahite . . . . . 1085<sup>a</sup>  
 Ezri . . . . . 1085<sup>b</sup>  
 Ezril . . . . . 1085<sup>b</sup>
- Fable . . . . . 1085<sup>a</sup> (Easton)  
   of Allegory . . . . . 97<sup>b</sup> (Schodde)  
   Of Jotham . . . . . 1754<sup>a</sup> (Caldecott)  
   of Parable . . . . . 2243<sup>a</sup> (Schodde)  
 Face . . . . . 1085<sup>b</sup> (Luering)  
   of Countenance . . . . . 723<sup>b</sup> (Luering)  
   of Forehead . . . . . 1127<sup>b</sup> (Luering)  
   of Spit . . . . . 2846<sup>a</sup> (T. Lewis)  
 Fact . . . . . 1086<sup>a</sup>  
 Fade . . . . . 1086<sup>a</sup> (W. L. Walker)  
 Fail . . . . . 1086<sup>a</sup> (W. L. Walker)  
 Fain . . . . . 1086<sup>b</sup> (W. L. Walker)  
   of Almost . . . . . 100<sup>b</sup> (Harry)  
 Faint . . . . . 1086<sup>b</sup> (Macalister)  
 Fair . . . . . 1087<sup>a</sup> (Luering)  
 Fair Havens . . . . . 1087<sup>b</sup>  
   of Crete . . . . . 744<sup>b</sup> (Calder)  
   of Lasea . . . . . 1840<sup>a</sup>  
 Fairs . . . . . 1087<sup>b</sup>  
   of Wares . . . . . 3072<sup>a</sup> (Raffety)  
 Faith . . . . . 1087<sup>b</sup> (Dunelm)  
   Of Abraham . . . . . 1088<sup>a</sup>  
   Active and passive . . . 1088<sup>a</sup>  
   As creed . . . . . 1088<sup>a</sup>  
   Centrality of . . . . . 1088<sup>a</sup>  
   Etymology, English . . . 1087<sup>b</sup>  
   Etymology, NT . . . . . 1087<sup>b</sup>  
   Etymology, OT . . . . . 1087<sup>b</sup>  
   of Hope . . . . . 1419<sup>b</sup> (Easton)  
   of Justification . . . . . 1783<sup>b</sup> (Faulkner)  
   Of Moses . . . . . 1088<sup>a</sup>  
   Of Rahab . . . . . 1088<sup>a</sup>  
 Faithful, Faithfulness . . . 1088<sup>b</sup> (Hodge)  
   of Doctrine of, in  
     Habakkuk . . . . . 1313<sup>a</sup> (Eiselen)  
   Faithfulness of God  
     In NT . . . . . 1090<sup>a</sup>  
     In OT . . . . . 1088<sup>b</sup>  
   of Immutability . . . . . 1461<sup>b</sup>  
   of Righteousness . . . . . 2591<sup>a</sup> (McConnell)  
   of Truth . . . . . 3025<sup>a</sup> (Carver)  
   of Unchangeable, Unchangeableness . . . 3033<sup>a</sup> (Hodge)  
 Faithful Sayings . . . . . 1091<sup>a</sup> (Rutherford)  
   of Poetry, NT . . . . . 2414<sup>b</sup> (Schenk)  
 Faithless . . . . . 1091<sup>b</sup>  
 Falcon . . . . . 1091<sup>b</sup> (Stratton-Porter)  
   of Hawk . . . . . 1345<sup>a</sup> (Stratton-Porter)  
 Fall (noun) . . . . . 1092<sup>a</sup> (Bavinck)  
   of Adam in OT and Apoc. . . . . 49<sup>a</sup> (Genung)  
   of Adam in OT (Evolutionary Interpretation) . . . . . 52<sup>a</sup> (Genung)  
   Babylonian seal . . . . . 1093<sup>a</sup>  
   Character of . . . . . 1093<sup>b</sup>  
   And Evolution . . . . . 1093<sup>a</sup>  
   Meaning of Gen 3 . . . . . 1092<sup>a</sup>  
   In the OT and NT . . . 1092<sup>b</sup>  
   of Psychology . . . . . 2498<sup>b</sup> (Marais)  
 Fall (verb) . . . . . 1092<sup>a</sup> (W. L. Walker)  
 Falling Stars . . . . . 1094<sup>a</sup>  
   of Astronomy . . . . . 300<sup>b</sup> (Maunder)  
 Fallow . . . . . 1094<sup>a</sup>  
   of Ground . . . . . 1307<sup>a</sup> (W. L. Walker)  
 False Christs . . . . . 628<sup>b</sup> (Orr)  
   of Lie, Lying . . . . . 1887<sup>a</sup> (W. Evans)  
 Falsehood . . . . . 746<sup>b</sup> (Hirsch)  
   of Lie, Lying . . . . . 1887<sup>a</sup> (W. Evans)  
 False Prophets . . . . . 1094<sup>a</sup>  
   of Lie, Lying . . . . . 1887<sup>a</sup> (W. Evans)  
   of Prophesyings, False 2466<sup>b</sup> (Schenk)  
 False Swearing, Witness . . 1094<sup>a</sup>  
   of Crimes . . . . . 745<sup>b</sup> (Hirsch)  
   of Lie, Lying . . . . . 1887<sup>a</sup> (W. Evans)  
   of Oath . . . . . 2172<sup>b</sup> (Levertoff)  
 Fame . . . . . 1094<sup>a</sup> (W. L. Walker)

- Familiar . . . . . 1094<sup>a</sup> (Pollard)  
 of Astrology . . . . . 295<sup>b</sup> (Maunder)  
 of Communion with  
 Demons . . . . . 689<sup>b</sup> (Sweet)
- Familiar Spirit  
 of Vault . . . . . 3046<sup>b</sup>  
 of Witch . . . . . 3097<sup>a</sup> (T. W. Davies)
- Family . . . . . 1094<sup>b</sup> (Caverno)  
 of Affinity . . . . . 66<sup>a</sup> (W. W. Davies)  
 of Covetousness . . . . . 733<sup>b</sup> (W. Evans)  
 of Divorce in OT . . . . . 863<sup>b</sup> (W. W. Davies)  
 Equality of sexes . . . . . 1095<sup>a</sup>  
 Fifth Commandment . . . . . 1095<sup>b</sup>  
 Foundation of . . . . . 1094<sup>b</sup>  
 of Hammurabi, Code  
 of . . . . . 1330<sup>a</sup> (Ungnad)  
 of Heredity . . . . . 1376<sup>a</sup> (Easton)  
 of Husband's Brother . . . . . 1442<sup>b</sup> (Crannell)  
 Modern dangers . . . . . 1096<sup>b</sup>  
 Monogamy the ideal . . . . . 1095<sup>a</sup>  
 In NT . . . . . 1096<sup>b</sup>  
 of Patrimony . . . . . 2264<sup>a</sup> (Mack)  
 Polygamy . . . . . 1095<sup>a</sup>  
 of Polygamy . . . . . 2416<sup>a</sup> (Caverno)  
 Reforms of Ezra and  
 Nehemiah . . . . . 1096<sup>a</sup>  
 of Relationships, Fam-  
 ily . . . . . 2554<sup>a</sup> (N. and E. D. Isaacs)  
 Seventh Command-  
 ment . . . . . 1095<sup>b</sup>  
 Teachings of Jesus . . . . . 1096<sup>b</sup>  
 Teachings of Paul . . . . . 1096<sup>b</sup>  
 Tenth Commandment . . . . . 1096<sup>a</sup>
- Family Relationships . . . . . 2554<sup>a</sup> (N. and E. D. Isaacs)
- Famine . . . . . 1097<sup>a</sup> (W. L. Walker)
- Famish . . . . . 1097<sup>b</sup> (W. L. Walker)
- Fan, Fanner . . . . . 1097<sup>b</sup> (Patch)
- Fancy . . . . . 1097<sup>b</sup>
- Far, Farther . . . . . 1097<sup>b</sup> (W. L. Walker)
- Far House . . . . . 1098<sup>a</sup>  
 of Beth-merhak . . . . . 450<sup>b</sup>
- Fare . . . . . 1098<sup>a</sup> (Williams)  
 of Farewell . . . . . 1098<sup>a</sup> (W. L. Walker)
- Farewell . . . . . 1098<sup>a</sup> (W. L. Walker)  
 of Fare . . . . . 1098<sup>a</sup> (Williams)  
 of Greeting . . . . . 1305<sup>a</sup> (W. L. Walker)
- Farm . . . . . 1098<sup>a</sup> (Patch)
- Farthing . . . . . 1098<sup>b</sup>  
 of Penny . . . . . 2298<sup>a</sup>
- Fashion . . . . . 1098<sup>b</sup> (Edwards)
- Fast, Fasting . . . . . 1099<sup>a</sup> (T. Lewis)  
 of Abstinence . . . . . 24<sup>b</sup> (Eager)  
 of Feasts and Fasts . . . . . 1103<sup>a</sup> (E. D. Isaacs)  
 of Jesus Christ . . . . . 1641<sup>a</sup> (Orr)
- Fasts and Feasts . . . . . 1103<sup>a</sup> (E. D. Isaacs)
- Fat (figurative) . . . . . 1100<sup>a</sup> (Luering)
- Fat (in sacrifice) . . . . . 1099<sup>b</sup> (Luering)  
 of Fowl (Fatted) . . . . . 1142<sup>b</sup> (W. L. Walker)  
 of Grease . . . . . 1294<sup>a</sup>  
 of Kidneys . . . . . 1797<sup>b</sup> (Easton)
- Father . . . . . 1100<sup>a</sup> (Crannell)
- Father (Ab) . . . . . 2<sup>b</sup>
- Father, God the . . . . . 1100<sup>b</sup> (Orr)  
 of Children of God . . . . . 608<sup>a</sup> (Rees)  
 of Trinity . . . . . 3012<sup>a</sup> (Warfield)
- Father-in-Law . . . . . 1101<sup>a</sup>  
 of Family . . . . . 1094<sup>b</sup> (Caverno)  
 of Relationships, Fam-  
 ily . . . . . 2554<sup>a</sup> (N. and E. D. Isaacs)
- Fatherless . . . . . 1101<sup>a</sup> (Edwards)  
 of Orphan . . . . . 2202<sup>a</sup>
- Father's Brother . . . . . 1101<sup>a</sup>  
 of Family . . . . . 1094<sup>b</sup> (Caverno)  
 of Relationships, Fam-  
 ily . . . . . 2554<sup>a</sup> (N. and E. D. Isaacs)
- Father's House, Fathers'  
 Houses . . . . . 1101<sup>a</sup> (W. L. Walker)
- Fathom . . . . . 1101<sup>b</sup>  
 of Weights and Meas-  
 ures . . . . . 3079<sup>a</sup> (Porter)
- Fatling, Fatted  
 of Calf . . . . . 542<sup>a</sup> (Day)  
 of Fat (in sacrifice) . . . . . 1099<sup>b</sup> (Luering)
- Fatness . . . . . 1101<sup>b</sup> (W. L. Walker)
- Fauchion  
 of Scimitar . . . . . 2703<sup>a</sup>
- Fault . . . . . 1101<sup>b</sup> (W. L. Walker)
- Favor . . . . . 1102<sup>a</sup> (W. L. Walker)
- Fawn  
 of Deer . . . . . 817<sup>a</sup> (Day)
- Fear . . . . . 1102<sup>a</sup> (W. L. Walker)
- Fearful . . . . . 1102<sup>a</sup> (W. L. Walker)
- Fearfully . . . . . 1102<sup>a</sup> (W. L. Walker)
- Fearfulness . . . . . 1102<sup>a</sup> (W. L. Walker)
- Feast of Ingathering  
 of Feasts and Fasts . . . . . 1103<sup>a</sup> (E. D. Isaacs)
- Feast of Tabernacles  
 of Goodly Trees . . . . . 1278<sup>b</sup> (Masterman)
- Feasting  
 of Triclinium . . . . . 3011<sup>a</sup> (N. Isaacs)
- Feasts and Fasts . . . . . 1103<sup>a</sup> (E. D. Isaacs)  
 of Fast, Fasting . . . . . 1099<sup>a</sup> (T. Lewis)  
 of Solemn, Solemnity . . . . . 2821<sup>b</sup> (Easton)
- Feasts, Seasons for . . . . . 1104<sup>a</sup>  
 of Astronomy . . . . . 300<sup>b</sup> (Maunder)
- Feathers . . . . . 1104<sup>b</sup> (Stratton-Porter)
- Feeble Knees . . . . . 1104<sup>b</sup> (Luering)  
 of Palsy . . . . . 2236<sup>a</sup> (Macalister)
- Feeble-minded . . . . . 1105<sup>a</sup>
- Feeling . . . . . 1105<sup>a</sup> (Luering)
- Feet, Washing of . . . . . 3072<sup>b</sup> (Anderson; Kurtz)  
 of Foot . . . . . 1125<sup>a</sup> (Luering)  
 of Hair, Symbolical  
 Use . . . . . 1321<sup>b</sup> (Luering)  
 of Lord's Supper . . . . . 1929<sup>a</sup> (Kurtz)
- Feign . . . . . 1105<sup>a</sup> (W. L. Walker)
- Felix Antonius . . . . . 1105<sup>b</sup> (Kerr)  
 of Assassins . . . . . 288<sup>a</sup> (S. F. Hunter)  
 of Festus, Porcius . . . . . 1107<sup>a</sup> (Kerr)  
 of Gallio . . . . . 1167<sup>b</sup> (Kerr)  
 of Governor . . . . . 1289<sup>b</sup> (Heidel)  
 of Paul . . . . . 2272<sup>a</sup> (A. T. Robertson)  
 of Tertullus . . . . . 2949<sup>b</sup> (Kerr)

- Felloes . . . . . 1106<sup>a</sup>  
   of Wheel . . . . . 3082<sup>b</sup> (Easton)  
 Fellow . . . . . 1106<sup>a</sup> (W. L. Walker)  
 Fellow-citizen, Fellow-disciple, Fellow-heirs . . . . . 1106<sup>a</sup> (W. L. Walker)  
 Fellowship  
   of Communion . . . . . 688<sup>b</sup> (Miller)  
 Female . . . . . 1106<sup>b</sup> (Luering)  
 Fence . . . . . 1106<sup>b</sup> (W. L. Walker)  
   of Hedge . . . . . 1366<sup>b</sup> (Masterman)  
 Fenced Cities  
   of Fortification . . . . . 1136<sup>b</sup> (Nicol)  
 Ferret . . . . . 1106<sup>b</sup> (Day)  
   of Chameleon . . . . . 592<sup>a</sup> (Day)  
   of Gecko . . . . . 1181<sup>a</sup>  
   of Lizard . . . . . 1906<sup>a</sup> (Day)  
 Ferry-boat  
   of Ships and Boats . . . . . 2774<sup>a</sup> (Nicol)  
 Fervent, Fervently . . . . . 1107<sup>a</sup> (W. L. Walker)  
 Festival  
   of Feasts and Fasts . . . . . 1103<sup>a</sup> (E. D. Isaacs)  
 Festus, Porcius . . . . . 1107<sup>a</sup> (Kerr)  
   of Felix Antonius . . . . . 1105<sup>b</sup> (Kerr)  
   of Gallio . . . . . 1167<sup>b</sup> (Kerr)  
   of Governor . . . . . 1289<sup>b</sup> (Heidel)  
   of Paul . . . . . 2272<sup>a</sup> (A. T. Robertson)  
 Fetch . . . . . 1107<sup>b</sup> (W. L. Walker)  
 Fetter . . . . . 1107<sup>b</sup>  
   of Chain . . . . . 589<sup>a</sup> (Fortune)  
 Fever . . . . . 1107<sup>b</sup> (Macalister)  
   of Ague . . . . . 78<sup>a</sup> (Macalister)  
   of Fiery Heat . . . . . 1108<sup>b</sup>  
   of Inflammation . . . . . 1468<sup>a</sup>  
 Field  
   of Agriculture . . . . . 75<sup>b</sup> (Patch)  
 Fierceness  
   of Fury . . . . . 1150<sup>b</sup>  
 Fiery Heat . . . . . 1108<sup>b</sup>  
   of Fever . . . . . 1107<sup>b</sup> (Macalister)  
 Fiery Serpent  
   of Serpent . . . . . 2736<sup>a</sup> (Day)  
 Fig, Fig-tree . . . . . 1108<sup>b</sup> (Masterman)  
   of Food . . . . . 1122<sup>b</sup> (Eager)  
 Fight  
   of Games . . . . . 1168<sup>b</sup> (Smith)  
   of War . . . . . 3069<sup>b</sup> (Nicol)  
 Figure . . . . . 1109<sup>b</sup> (W. L. Walker)  
 File . . . . . 1110<sup>a</sup>  
   of Tools . . . . . 2999<sup>a</sup> (Easton)  
 Fillet . . . . . 1110<sup>a</sup> (Raffety)  
 Filth, Filthiness, Filthy . . . . . 1110<sup>b</sup> (W. L. Walker)  
   of Uncleaness . . . . . 3035<sup>b</sup> (Williams)  
 Fin  
   of Fish . . . . . 1114<sup>b</sup> (Day)  
 Fine . . . . . 1110<sup>b</sup> (W. L. Walker)  
 Finer, Fining  
   of Refiner . . . . . 2545<sup>a</sup> (Patch)  
 Fines  
   of Punishments . . . . . 2504<sup>b</sup> (Hirsch)  
 Finger . . . . . 1111<sup>a</sup> (Luering)  
   of Weights and Measures . . . . . 3079<sup>a</sup> (Porter)  
 Finish . . . . . 1111<sup>b</sup> (W. L. Walker)  
 Finisher . . . . . 1111<sup>b</sup> (W. L. Walker)  
 Fir, Fir-tree . . . . . 1111<sup>b</sup> (Masterman)  
 Fire . . . . . 1112<sup>a</sup> (W. L. Walker)  
   of Idolatry . . . . . 1447<sup>b</sup> (Cobern)  
   of Molech . . . . . 2074<sup>a</sup> (Nicol)  
 Fire Baptism  
   of Baptism of Fire . . . . . 399<sup>b</sup> (Kapp)  
   of Molech . . . . . 2074<sup>a</sup> (Nicol)  
 Fire, Lake of . . . . . 1822<sup>a</sup> (Vos)  
 Fire, Strange . . . . . 1112<sup>b</sup>  
   of Fire . . . . . 1112<sup>a</sup> (W. L. Walker)  
 Fire, Unquenchable . . . . . 3038<sup>a</sup> (Orr)  
 Firebrand . . . . . 1112<sup>b</sup> (W. L. Walker)  
   of Brand . . . . . 514<sup>a</sup>  
 Firepan . . . . . 1113<sup>a</sup> (Harry)  
   of Censer . . . . . 587<sup>b</sup> (T. Lewis)  
 Fires . . . . . 1113<sup>a</sup>  
 Firkin . . . . . 1113<sup>a</sup>  
   of Weights and Measures . . . . . 3079<sup>a</sup> (Porter)  
 Firmament . . . . . 300<sup>b</sup> (Maunder)  
 First . . . . . 1113<sup>a</sup> (W. L. Walker)  
 First-begotten . . . . . 1113<sup>a</sup> (Rees); 426<sup>b</sup> (Rees)  
   of Firstborn, Firstling . . . . . 1113<sup>b</sup> (T. Lewis)  
 Firstborn, Firstling . . . . . 1113<sup>b</sup> (T. Lewis)  
   of Child . . . . . 606<sup>b</sup> (Stearns)  
   of Circumcision . . . . . 656<sup>b</sup> (T. Lewis)  
   of First-begotten . . . . . 1113<sup>a</sup> (Rees)  
   of Heir . . . . . 1369<sup>a</sup> (Easton)  
   of Plagues of Egypt . . . . . 2405<sup>b</sup> (Kyle)  
   of Priests and Levites . . . . . 2446<sup>b</sup> (Wiener)  
   of Primogeniture . . . . . 2452<sup>b</sup> (N. Isaacs)  
   Redemption of . . . . . 1114<sup>a</sup>  
 First-fruits . . . . . 1114<sup>a</sup> (Levertoff)  
   of Priests and Levites . . . . . 2446<sup>b</sup> (Wiener)  
   of Tithe . . . . . 2987<sup>b</sup> (Levertoff)  
 First Principles  
   of Rudiments . . . . . 2624<sup>b</sup> (Rutherford)  
 Fish . . . . . 1114<sup>b</sup> (Day)  
   Fishing . . . . . 1115<sup>a</sup>  
   Jonah's fish . . . . . 1115<sup>a</sup>  
   of Sea Food . . . . . 1123<sup>b</sup> (Eager)  
   of Whale . . . . . 3082<sup>a</sup> (Day)  
 Fisher, Fisherman . . . . . 1115<sup>b</sup> (Patch)  
 Fish Gate  
   of Jerusalem . . . . . 1607<sup>a</sup> (Masterman)  
   of Mishneh . . . . . 2066<sup>b</sup> (Masterman)  
 Fisher's Coat . . . . . 1116<sup>a</sup>  
   of Dress . . . . . 875<sup>b</sup> (Eager)  
 Fishhook . . . . . 1116<sup>a</sup> (Patch)  
   of Fishing . . . . . 1116<sup>a</sup> (Patch)  
 Fishing . . . . . 1116<sup>a</sup> (Patch)  
   of Fishhook . . . . . 1116<sup>a</sup> (Patch)  
   of Galilee, Sea of . . . . . 1165<sup>a</sup> (Ewing)  
 Fishpools . . . . . 1117<sup>a</sup>  
 Fit, Fitly . . . . . 1117<sup>a</sup> (W. L. Walker)  
 Fitches (Vetch) . . . . . 1117<sup>a</sup> (Masterman)  
   of Food . . . . . 1121<sup>b</sup> (Eager)



- Five  
 of Number . . . . . 2157<sup>a</sup> (Smith)
- Flag . . . . . 1117<sup>b</sup>  
 of Reed . . . . . 2544<sup>a</sup> (Masterman)
- Flagon . . . . . 1117<sup>b</sup> (Hovey)  
 of Wine . . . . . 3086<sup>b</sup> (Easton)
- Flake . . . . . 1117<sup>b</sup> (Luering)
- Flame . . . . . 1117<sup>b</sup> (W. L. Walker)  
 of Fire . . . . . 1112<sup>a</sup> (W. L. Walker)
- Flat Nose . . . . . 1117<sup>b</sup> (Macalister)
- Flax . . . . . 1118<sup>a</sup> (Masterman)  
 of Linen . . . . . 1894<sup>a</sup> (E. D. Isaacs)
- Flying  
 of Punishments . . . . . 2504<sup>b</sup> (Hirsch)
- Flea . . . . . 1118<sup>b</sup> (Day)  
 of Gnat . . . . . 1240<sup>a</sup> (Day)  
 of Lice . . . . . 1886<sup>b</sup> (Day)  
 of Sand Flies . . . . . 2688<sup>b</sup>
- Flee  
 of Fly (verb) . . . . . 1121<sup>a</sup> (W. L. Walker)
- Fleece  
 of Gideon . . . . . 1226<sup>b</sup> (Schenk)  
 of Sheep . . . . . 2756<sup>b</sup> (Day)  
 of Wool . . . . . 3104<sup>b</sup> (Patch)
- Fleet, Roman . . . . . 257<sup>b</sup> (Allen)
- Flesh . . . . . 1118<sup>b</sup> (Luering)  
 of Resurrection . . . . . 2565<sup>a</sup> (Easton)  
 of Sinlessness . . . . . 2805<sup>b</sup> (Dunelm)  
 of Spirit . . . . . 2841<sup>b</sup> (Marais)
- Flesh and Blood . . . . . 1119<sup>b</sup>  
 of Flesh . . . . . 1118<sup>b</sup> (Luering)
- Flesh-hook . . . . . 1119<sup>b</sup> (Doolan)  
 of Hook . . . . . 1419<sup>a</sup> (Easton)
- Flesh-pot . . . . . 1119<sup>b</sup>  
 of Food . . . . . 1121<sup>b</sup> (Eager)
- Flies  
 of Fly, Flies . . . . . 1120<sup>b</sup> (Day)  
 of Plagues of Egypt . . . . . 2404<sup>b</sup> (Kyle)
- Flint . . . . . 1119<sup>a</sup> (Day)  
 of Rock . . . . . 2596<sup>a</sup> (Day)  
 of Stone, Stones . . . . . 2856<sup>a</sup> (Day)
- Float (Flote)  
 of Ships and Boats . . . . . 2774<sup>a</sup> (Nicol)
- Flock  
 of Cattle . . . . . 583<sup>b</sup> (Day)
- Flood . . . . . 1120<sup>a</sup> (Day)  
 of Deluge of Noah . . . . . 821<sup>b</sup> (Wright)  
 of Geological Theory  
 of . . . . . 230<sup>a</sup> (Kyle)
- Floor  
 of House . . . . . 1434<sup>b</sup> (A. C. Dickie)  
 of Threshing-floor . . . . . 2975<sup>b</sup> (Patch)
- Flote (Float)  
 of Ships and Boats . . . . . 2774<sup>a</sup> (Nicol)
- Flour  
 of Bread . . . . . 514<sup>b</sup> (Eager)  
 of Food . . . . . 1121<sup>b</sup> (Eager)
- Flourish . . . . . 1120<sup>a</sup> (W. L. Walker)  
 of Almond . . . . . 100<sup>a</sup> (Masterman)
- Flowers (Bloom, Blossom, etc) . . . . . 1120<sup>b</sup> (Masterman)  
 of Botany . . . . . 505<sup>a</sup> (Masterman)
- Flue Net  
 of Fish . . . . . 1114<sup>b</sup> (Day)  
 of Fishing . . . . . 1116<sup>a</sup> (Patch)
- Flute  
 of Music . . . . . 2094<sup>b</sup> (Millar)
- Flux  
 of Bloody Flux . . . . . 490<sup>b</sup> (Macalister)  
 of Dysentery . . . . . 884<sup>b</sup> (Macalister)
- Fly (verb) . . . . . 1121<sup>a</sup> (W. L. Walker)
- Fly, Flies . . . . . 1120<sup>b</sup> (Day)  
 of Plague . . . . . 2402<sup>b</sup> (Macalister)
- Foal . . . . . 1121<sup>a</sup>  
 of Colt . . . . . 678<sup>a</sup> (Day)
- Foam . . . . . 1121<sup>a</sup> (Day)
- Fodder  
 of Provender . . . . . 2469<sup>b</sup> (Masterman)
- Fold, Folding . . . . . 1121<sup>a</sup> (W. L. Walker)  
 of House . . . . . 1434<sup>b</sup> (A. C. Dickie)
- Folk . . . . . 1121<sup>b</sup> (W. L. Walker)
- Folk-lore  
 of Night-monster . . . . . 2144<sup>a</sup> (Sweet)
- Follow . . . . . 1121<sup>b</sup> (W. L. Walker)
- Follower . . . . . 1121<sup>b</sup>
- Folly  
 of Fool . . . . . 1124<sup>a</sup> (W. L. Walker)
- Food . . . . . 1121<sup>b</sup> (Eager)  
 of Abomination . . . . . 15<sup>b</sup> (Eager)  
 of Apple . . . . . 209<sup>a</sup> (Masterman)  
 of Bread . . . . . 514<sup>b</sup> (Eager)  
 Butter . . . . . 1123<sup>b</sup>  
 Cereals . . . . . 1122<sup>a</sup>  
 of Clean . . . . . 667<sup>b</sup> (Crannell)  
 of Coriander . . . . . 710<sup>a</sup>  
 of Fitches . . . . . 1117<sup>a</sup> (Masterman)  
 of Flesh-pot . . . . . 1119<sup>b</sup>  
 Goat . . . . . 1123<sup>a</sup>  
 of Honey . . . . . 1418<sup>b</sup> (Patch)  
 Leguminous plants . . . . . 1122<sup>a</sup>  
 of Locust . . . . . 1907<sup>b</sup> (Day)  
 of Meal . . . . . 2013<sup>b</sup>  
 of Meals, Meal-time . . . . . 2013<sup>b</sup> (Eager)  
 of Milk . . . . . 2051<sup>b</sup> (N. Isaacs)  
 of Mill . . . . . 2052<sup>a</sup> (Patch)  
 of Oil . . . . . 2182<sup>b</sup> (Patch)  
 of Pot . . . . . 2423<sup>a</sup> (Betteridge)  
 Primitive habits . . . . . 1121<sup>b</sup>  
 of Salt . . . . . 2664<sup>a</sup> (Patch)  
 Sheep . . . . . 1123<sup>b</sup>  
 Of trees . . . . . 1122<sup>b</sup>  
 of Uncleaness . . . . . 3036<sup>a</sup> (Williams)  
 of Wheat . . . . . 3082<sup>b</sup> (Masterman)  
 of Wine . . . . . 3086<sup>a</sup> (Easton)
- Fool, Folly . . . . . 1124<sup>a</sup> (W. L. Walker)  
 of Wisdom . . . . . 3089<sup>a</sup> (Easton)
- Foolery . . . . . 1125<sup>a</sup> (W. L. Walker)
- Foot . . . . . 1125<sup>a</sup> (Luering)
- Footgear . . . . . 879<sup>a</sup> (Eager)  
 of Shoe, Shoe-latchet . . . . . 2779<sup>a</sup> (Easton)
- Footman  
 of War . . . . . 3069<sup>b</sup> (Nicol)

- Footstool . . . . . 1126<sup>a</sup> (Doolan)  
   of Neck . . . . . 2129<sup>a</sup> (Luering)  
 For . . . . . 1126<sup>b</sup> (W. L. Walker)  
 Foray . . . . . 1126<sup>b</sup>  
   of War . . . . . 3069<sup>b</sup> (Nicol)  
 Forbear . . . . . 1126<sup>b</sup> (W. L. Walker)  
 Forbearance . . . . . 1126<sup>b</sup> (W. L. Walker)  
 Forbid . . . . . 1127<sup>a</sup> (W. L. Walker)  
 Forces . . . . . 1127<sup>a</sup>  
 Ford . . . . . 1127<sup>a</sup> (Day)  
   of Jordan . . . . . 1732<sup>b</sup> (Wright)  
 Forecast . . . . . 1127<sup>b</sup> (W. L. Walker)  
 Forefather . . . . . 1127<sup>b</sup>  
 Forefront . . . . . 1127<sup>b</sup> (W. L. Walker)  
 Forego  
   of Forgo . . . . . 1135<sup>b</sup>  
 Forehead . . . . . 1127<sup>b</sup> (Luering)  
   of Face . . . . . 1085<sup>b</sup> (Luering)  
   of Taw . . . . . 2913<sup>a</sup>  
 Foreign Divinities  
   of Gods (Strange) . . . . . 1272<sup>a</sup> (Betteridge)  
 Foreigner . . . . . 1128<sup>a</sup>  
   of Alien . . . . . 97<sup>a</sup> (Hirsch)  
   of Stranger and So-  
   journer in the OT . . . . . 2865<sup>a</sup> (Wiener)  
 Foreknow, Foreknowl-  
   edge . . . . . 1128<sup>a</sup> (Hodge)  
   And foreordination . . . . . 1129<sup>b</sup>  
   of Knowledge . . . . . 1815<sup>b</sup> (Orr)  
   of Omniscience . . . . . 2191<sup>a</sup> (Vos)  
   of Predestination . . . . . 2435<sup>a</sup> (J. Lindsay)  
 Foreordain, Foreordi-  
   nation . . . . . 1131<sup>a</sup> (Orr); 1129<sup>b</sup> (Hodge)  
   of Choose . . . . . 612<sup>b</sup> (Rees)  
   of Election . . . . . 925<sup>b</sup> (Dunelm)  
   of Judas as Betrayer . . . . . 1766<sup>b</sup> (Kerr)  
   of Predestination . . . . . 2435<sup>a</sup> (J. Lindsay)  
   of Providence . . . . . 2476<sup>b</sup> (Tillett)  
   of Purpose of God . . . . . 2510<sup>a</sup>  
 Forepart . . . . . 1131<sup>a</sup>  
 Forerunner . . . . . 1131<sup>a</sup> (W. Evans)  
   of John the Baptist . . . . . 1708<sup>b</sup> (Miller)  
 Foresail  
   of Ships and Boats . . . . . 2774<sup>a</sup> (Nicol)  
 Foreship  
   of Forepart . . . . . 1131<sup>a</sup>  
   of Ships and Boats . . . . . 2774<sup>a</sup> (Nicol)  
 Foreskin . . . . . 1131<sup>b</sup> (Luering)  
   of Circumcision . . . . . 656<sup>b</sup> (T. Lewis)  
   of Concision . . . . . 696<sup>b</sup>  
 Forest . . . . . 1132<sup>a</sup> (Masterman)  
   of Botany . . . . . 505<sup>a</sup> (Masterman)  
   of Thicket . . . . . 2972<sup>a</sup>  
 Forest of Ephraim . . . . . 963<sup>b</sup>  
   of Ephraim . . . . . 963<sup>b</sup> (Ewing)  
 Foretell, Foretold . . . . . 1132<sup>a</sup>  
   of Prophecy . . . . . 2459<sup>b</sup> (Orelli)  
 Forfeit . . . . . 1132<sup>a</sup> (W. L. Walker)  
 Forge, Forger . . . . . 1132<sup>b</sup> (W. L. Walker)  
 Forget, Forgetful . . . . . 1132<sup>b</sup> (W. L. Walker)  
 Forgiveness . . . . . 1132<sup>b</sup> (Morro)  
   of Absolution . . . . . 24<sup>a</sup> (Jacobs)  
   And atonement . . . . . 1135<sup>a</sup>  
     of Atonement . . . . . 627<sup>b</sup> (Orr)  
   of Blasphemy . . . . . 485<sup>b</sup> (Rees)  
   Etymology . . . . . 1132<sup>b</sup>  
   of Hope . . . . . 1419<sup>b</sup> (Easton)  
   of Keys, Power of . . . . . 1794<sup>a</sup> (Carver)  
   of Law in NT . . . . . 1844<sup>a</sup> (M'Caig)  
   Limitations . . . . . 1134<sup>b</sup>  
   OT teaching . . . . . 1134<sup>b</sup>  
   Pagan and Jewish  
     ideas . . . . . 1133<sup>a</sup>  
   of Remission . . . . . 2557<sup>b</sup> (Jacobs)  
   of Salvation . . . . . 2668<sup>a</sup> (Easton)  
   Teaching of Jesus . . . . . 1133<sup>a</sup>  
 Forgo . . . . . 1135<sup>b</sup>  
 Fork . . . . . 1136<sup>a</sup>  
 Form . . . . . 1136<sup>a</sup> (W. L. Walker)  
 Former . . . . . 1136<sup>a</sup> (W. L. Walker)  
 Fornication  
   of Crimes . . . . . 745<sup>b</sup> (Hirsch)  
 Forswear  
   of Crimes . . . . . 745<sup>b</sup> (Hirsch)  
 Fort . . . . . 1136<sup>b</sup> (Nicol)  
 Forth . . . . . 1136<sup>b</sup> (W. L. Walker)  
 Fortification . . . . . 1136<sup>b</sup> (Nicol)  
   of Canaan . . . . . 549<sup>a</sup> (Sayce)  
   of City . . . . . 662<sup>a</sup> (A. C. Dickie)  
   of Corner-stone . . . . . 721<sup>b</sup> (Mack)  
   Gates . . . . . 1138<sup>a</sup>  
     of Gate . . . . . 1175<sup>b</sup> (Easton)  
   of Gezer . . . . . 1222<sup>a</sup> (Masterman)  
   of Hold . . . . . 1403<sup>a</sup>  
   of Jerusalem . . . . . 1595<sup>b</sup> (Masterman)  
   Masonry . . . . . 1138<sup>a</sup>  
   Recent excavations . . . . . 1137<sup>a</sup>  
   of Siege . . . . . 2786<sup>a</sup> (Nicol)  
   Towers . . . . . 1137<sup>b</sup>  
   Wells . . . . . 1137<sup>b</sup>  
 Fortified (Fenced) Cities . . . . . 1136<sup>b</sup> (Nicol)  
 Fortress . . . . . 1136<sup>b</sup> (Nicol)  
 Fortress of Masada . . . . . 808<sup>a</sup> (Wright)  
 Fortunatus . . . . . 1141<sup>a</sup>  
 Fortune . . . . . 1141<sup>a</sup>  
   of Divination . . . . . 860<sup>a</sup> (T. W. Davies)  
 Forty . . . . . 1141<sup>a</sup>  
   of Four . . . . . 1142<sup>a</sup> (W. L. Walker)  
   of Number . . . . . 2157<sup>a</sup> (Smith)  
 Forum . . . . . 1141<sup>a</sup>  
 Forum (Appii) . . . . . 1141<sup>a</sup>  
   of Market of Appius . . . . . 209<sup>a</sup> (Allen)  
 Forward, Forwardness . . . . . 1141<sup>a</sup> (W. L. Walker)  
 Foul . . . . . 1141<sup>b</sup> (W. L. Walker)  
 Foundation . . . . . 1141<sup>b</sup> (Orr)  
 Foundation Sacrifices  
   of Palestine, Recent  
     Exploration . . . . . 2228<sup>b</sup> (Cobern)  
 Founder  
   of Goldsmith . . . . . 1275<sup>a</sup> (Patch)  
   of Refiner . . . . . 2545<sup>a</sup> (Patch)

- Fountain . . . . . 1141<sup>b</sup> (Day)  
 cf Cistern, Well, Pool,  
 Aqueduct . . . . . 657<sup>b</sup> (A. C. Dickie)  
 cf En-eglaim . . . . . 944<sup>b</sup>  
 cf En-gedi . . . . . 945<sup>a</sup> (Wright)  
 cf En-rogel . . . . . 953<sup>b</sup> (Masterman)  
 cf Water . . . . . 3074<sup>a</sup> (Joy)  
 cf Well . . . . . 3081<sup>a</sup> (Day)
- Fountain Gate  
 cf Jerusalem . . . . . 1606<sup>b</sup> (Masterman)
- Four . . . . . 1142<sup>a</sup> (W. L. Walker)
- Four Hundred . . . . . 1142<sup>b</sup>  
 cf Four . . . . . 1142<sup>b</sup> (W. L. Walker)
- Four Thousand . . . . . 1142<sup>b</sup>  
 cf Four . . . . . 1142<sup>b</sup> (W. L. Walker)
- Fourfold . . . . . 1142<sup>b</sup>
- Fourscore . . . . . 1142<sup>b</sup>  
 cf Four . . . . . 1142<sup>b</sup> (W. L. Walker)  
 cf Number . . . . . 2157<sup>a</sup> (Smith)
- Foursquare . . . . . 1142<sup>b</sup> (W. L. Walker)
- Fourteen . . . . . 1142<sup>b</sup>  
 cf Number . . . . . 2157<sup>a</sup> (Smith)
- Fourth Part . . . . . 1142<sup>b</sup>  
 cf Four . . . . . 1142<sup>a</sup> (W. L. Walker)
- Fowl . . . . . 1142<sup>b</sup> (W. L. Walker)
- Fowl (Fatted)  
 cf Fat (in sacrifice) . . . 1099<sup>b</sup> (Luering)  
 cf Fowl . . . . . 1142<sup>b</sup> (W. L. Walker)
- Fowler . . . . . 1143<sup>a</sup> (Stratton-Porter)  
 cf Hunting . . . . . 1440<sup>a</sup> (Smith)  
 cf Snare . . . . . 2819<sup>a</sup> (Stratton-Porter)
- Fox . . . . . 1143<sup>b</sup> (Day)  
 cf Dragon . . . . . 873<sup>a</sup> (Day)  
 cf Jackal . . . . . 1548<sup>a</sup> (Day)
- Fragment . . . . . 1144<sup>a</sup> (W. L. Walker)
- Frame . . . . . 1144<sup>b</sup> (Luering)
- Frank Mountain  
 cf Jerusalem . . . . . 1611<sup>b</sup> (Masterman)
- Frankincense . . . . . 1144<sup>b</sup> (Masterman)  
 cf Incense . . . . . 1466<sup>b</sup> (Orr)
- Frankly . . . . . 1145<sup>a</sup>
- Fray . . . . . 1145<sup>a</sup>  
 cf War . . . . . 3069<sup>b</sup> (Nicol)
- Freckled Spot . . . . . 1145<sup>a</sup>  
 cf Leprosy . . . . . 1867<sup>a</sup> (Macalister)  
 cf Spot, Spotted . . . . . 2846<sup>b</sup> (Macalister)  
 cf Tetter . . . . . 2950<sup>a</sup>
- Free, Freedom  
 cf Choose . . . . . 612<sup>b</sup> (Rees)  
 cf Will . . . . . 3085<sup>a</sup> (W. L. Walker)
- Freedman . . . . . 1145<sup>a</sup>
- Freedom, Human  
 cf Sin . . . . . 2799<sup>a</sup> (McConnell)
- Freely . . . . . 1145<sup>a</sup> (W. L. Walker)
- Free Will  
 cf Omniscience . . . . . 2191<sup>b</sup> (Vos)
- Freewill Offering . . . . . 1145<sup>b</sup>
- Freewoman . . . . . 1145<sup>b</sup>
- Frequent . . . . . 1145<sup>b</sup> (W. L. Walker)
- Fresh . . . . . 1145<sup>b</sup> (W. L. Walker)
- Fret, Fretting . . . . . 1145<sup>b</sup> (W. L. Walker)
- Fried  
 cf Bread . . . . . 514<sup>b</sup> (Eager)  
 cf Food . . . . . 1121<sup>b</sup> (Eager)  
 cf Locusts . . . . . 1907<sup>b</sup> (Day)
- Friend, Friendship . . . . . 1146<sup>a</sup> (Clippinger)
- Friends, Chief Friends . . . 1146<sup>a</sup>
- Fringes . . . . . 1146<sup>b</sup> (E. D. Isaacs)  
 cf Dress . . . . . 875<sup>b</sup> (Eager)  
 cf Hem . . . . . 1374<sup>a</sup> (Eager)  
 cf Phylactery . . . . . 2392<sup>b</sup> (Mack)  
 cf Tassel . . . . . 2917<sup>b</sup> (Caldecott)
- Frock . . . . . 1147<sup>a</sup> (E. D. Isaacs)  
 cf Dress . . . . . 875<sup>b</sup> (Eager)
- Frog . . . . . 1147<sup>a</sup> (Day)  
 cf Plagues of Egypt . . . 2404<sup>b</sup> (Kyle)
- Frontier . . . . . 1147<sup>a</sup>
- Frontlets . . . . . 1147<sup>a</sup>  
 cf Phylactery . . . . . 2392<sup>b</sup> (Mack)
- Frost . . . . . 1147<sup>a</sup> (Joy)
- Frowardness . . . . . 1147<sup>b</sup>
- Fruit . . . . . 1147<sup>b</sup>  
 cf Apple . . . . . 209<sup>a</sup> (Masterman)  
 cf Botany . . . . . 505<sup>a</sup> (Masterman)  
 cf Fig . . . . . 1108<sup>b</sup> (Masterman)  
 cf Food . . . . . 1122<sup>b</sup> (Eager)  
 cf Vine . . . . . 3049<sup>b</sup> (Masterman)  
 cf Wine . . . . . 3086<sup>b</sup> (Easton)
- Frustrate . . . . . 1147<sup>b</sup> (W. L. Walker)
- Frying-pan . . . . . 1147<sup>b</sup>  
 cf Bread . . . . . 514<sup>b</sup> (Eager)  
 cf Pan . . . . . 2237<sup>a</sup> (Betteridge)
- Fuel . . . . . 1147<sup>b</sup> (Doolan)
- Fugitive . . . . . 1148<sup>a</sup>
- Fulfil . . . . . 1148<sup>a</sup> (W. L. Walker)
- Fuller . . . . . 1148<sup>a</sup> (Patch)  
 cf Wool . . . . . 3104<sup>b</sup> (Patch)
- Fuller's Field . . . . . 1148<sup>a</sup> (Masterman)  
 cf Gihon . . . . . 1228<sup>b</sup> (Masterman)  
 cf Jerusalem . . . . . 1608<sup>a</sup> (Masterman)
- Fuller's Fountain . . . . . 1148<sup>b</sup>  
 cf En-rogel . . . . . 953<sup>b</sup> (Masterman)
- Fulness . . . . . 1148<sup>b</sup> (Rutherford)  
 cf Gnosticism . . . . . 1240<sup>a</sup> (Rutherford)
- Funeral . . . . . 1149<sup>b</sup>  
 cf Burial . . . . . 529<sup>a</sup> (Eager)
- Furlong . . . . . 1149<sup>b</sup>  
 cf Weights and Meas-  
 ures . . . . . 3079<sup>a</sup> (Porter)
- Furnace . . . . . 1149<sup>b</sup> (Eager)
- Furnaces, Tower of the . . . 1149<sup>b</sup>  
 cf Jerusalem . . . . . 1595<sup>b</sup> (Masterman)
- Furnish . . . . . 1149<sup>b</sup> (W. L. Walker)
- Furniture . . . . . 1150<sup>a</sup> (Reeve)  
 cf House . . . . . 1434<sup>b</sup> (A. C. Dickie)  
 cf Tabernacle . . . . . 2887<sup>b</sup> (Caldecott; Orr)  
 cf Temple . . . . . 2930<sup>a</sup> (Caldecott; Orr)
- Furrow . . . . . 1150<sup>a</sup> (Patch)  
 cf Agriculture . . . . . 75<sup>b</sup> (Patch)  
 cf Plow . . . . . 2409<sup>a</sup> (Patch)
- Further, Furtherance . . . . 1150<sup>b</sup> (W. L. Walker)

- Fury . . . . . 1150<sup>b</sup>  
 of Anger . . . . . 135<sup>b</sup> (Farr)  
 of Wrath . . . . . 3113<sup>a</sup> (W. Evans)  
 Future . . . . . 1150<sup>b</sup>  
 of Eschatology, NT . . . . . 979<sup>b</sup> (Vos)  
 Future Life  
 of Greece, Religion in . . . . . 1303<sup>a</sup> (Fairbanks)
- Gaal . . . . . 1150<sup>a</sup>  
 of Abimelech . . . . . 11<sup>b</sup> (Mack)  
 Gaash . . . . . 1150<sup>a</sup>  
 of Ephraim, Mount . . . . . 963<sup>b</sup>  
 of Timnath-heres . . . . . 2983<sup>a</sup> (Ewing)
- Gaba . . . . . 1150<sup>a</sup>  
 of Geba . . . . . 1180<sup>a</sup> (Ewing)
- Gabael (Apoc) . . . . . 1150<sup>b</sup>  
 of Gabrias (Apoc) . . . . . 1151<sup>a</sup>
- Gabatha (Apoc) . . . . . 1150<sup>b</sup>
- Gabbai . . . . . 1150<sup>b</sup>
- Gabbatha . . . . . 1150<sup>b</sup> (Masterman)  
 of Judgment Seat . . . . . 1778<sup>a</sup>  
 of Pavement . . . . . 2292<sup>b</sup>  
 of Pilate, Pontius . . . . . 2397<sup>b</sup> (J. M. Wilson)  
 of Praetorium . . . . . 2428<sup>b</sup> (Masterman)
- Gabbe, Gabdes (Apoc) . . . . . 1151<sup>a</sup>  
 of Geba . . . . . 1180<sup>a</sup> (Ewing)
- Gabrias (Apoc) . . . . . 1151<sup>a</sup>  
 of Gabael (Apoc) . . . . . 1150<sup>b</sup>
- Gabriel . . . . . 1151<sup>a</sup> (Orr)  
 of Angel . . . . . 132<sup>b</sup> (J. M. Wilson)
- Gad (tribe)  
 History . . . . . 1151<sup>b</sup>
- Gad (verb) . . . . . 1152<sup>b</sup>
- Gad, God of Good Luck 1152<sup>a</sup> (Stearns)  
 of Astrology . . . . . 295<sup>b</sup> (Maunder)  
 of Meni . . . . . 2033<sup>a</sup>
- Gad, Seer of David . . . . . 1152<sup>a</sup> (E. D. Isaacs)
- Gad, Son of Jacob . . . . . 1151<sup>a</sup> (Ewing)
- Gad, Valley of (River of) 1152<sup>b</sup> (Ewing)  
 of Ar . . . . . 211<sup>a</sup> (Ewing)
- Gadara . . . . . 1152<sup>b</sup> (Ewing)  
 of Decapolis . . . . . 815<sup>a</sup> (Ewing)  
 of Gerasa . . . . . 1217<sup>b</sup> (Ewing)  
 of Gergesenes . . . . . 1218<sup>a</sup>
- Gadarenes . . . . . 1153<sup>a</sup>  
 of Gadara . . . . . 1152<sup>b</sup> (Ewing)  
 of Gergesenes . . . . . 1218<sup>a</sup>
- Gaddi . . . . . 1153<sup>a</sup>
- Gaddiel . . . . . 1153<sup>a</sup>
- Gaddis (Apoc) . . . . . 1153<sup>a</sup>
- Gadh and Meni . . . . . 299<sup>a</sup>
- Gadi . . . . . 1153<sup>a</sup>
- Gadites . . . . . 1153<sup>b</sup>
- Gaham . . . . . 1153<sup>b</sup>
- Gahar . . . . . 1153<sup>b</sup>  
 of Geddur (Apoc) . . . . . 1181<sup>b</sup>
- Gai . . . . . 1153<sup>b</sup>
- Gain . . . . . 1153<sup>b</sup> (Williams)
- Gainsay, Gainsayer, Gain-  
 saying . . . . . 1153<sup>b</sup> (W. L. Walker)
- Gaius . . . . . 1154<sup>a</sup> (Kerr)  
 of John, Epp. of . . . . . 1718<sup>b</sup> (Law)
- Galaad (Gilead) . . . . . 1154<sup>a</sup>
- Galal . . . . . 1154<sup>a</sup>
- Galatia . . . . . 1154<sup>a</sup> (Ramsay)  
 Churches of . . . . . 1155<sup>a</sup>  
 Evangelization of . . . . . 1155<sup>a</sup>  
 of Galatians, Ep. to 1155<sup>b</sup> (G. G. Findlay)  
 Gaulish kingdom . . . . . 1154<sup>b</sup>  
 Geographical and po-  
 litical . . . . . 1154<sup>a</sup>  
 of Location of . . . . . 1159<sup>b</sup> (G. G. Findlay)  
 of Paul, the Apostle . . . . . 2283<sup>a</sup> (A. T. Robertson)  
 of Region . . . . . 2550<sup>b</sup>  
 Roman Province . . . . . 1154<sup>b</sup>
- Galatians in Asia Minor 275<sup>a</sup> (Calder)  
 of Galatia . . . . . 1154<sup>a</sup> (Ramsay)  
 Paul's use of . . . . . 1155<sup>a</sup>
- Galatians, Epistle to the 1155<sup>b</sup> (G. G. Findlay)  
 Antiochs, the two . . . . . 1162<sup>a</sup>  
 Authorship . . . . . 1156<sup>a</sup>  
 Barnabas in . . . . . 1161<sup>b</sup>  
 Characteristics of . . . . . 1158<sup>a</sup>  
 Contents . . . . . 1156<sup>b</sup>  
 Controversial features  
 of . . . . . 1157<sup>b</sup>  
 Destination and date . . . . . 1159<sup>a</sup>  
 of Galatia . . . . . 1154<sup>a</sup> (Ramsay)  
 of Law in . . . . . 1850<sup>a</sup> (M'Caig)  
 Literature on . . . . . 1162<sup>b</sup>  
 of Paul, the Apostle . . . . . 2283<sup>a</sup> (A. T. Robertson)  
 Peter and Paul in . . . . . 1160<sup>b</sup>  
 Relations to Corin-  
 thians . . . . . 1158<sup>b</sup>  
 Relations to Romans . . . . . 1158<sup>a</sup>  
 Time notes in . . . . . 1160<sup>b</sup>
- Galbanum . . . . . 1163<sup>a</sup> (Masterman)
- Galeed . . . . . 1163<sup>a</sup> (Ewing)
- Galgala (Apoc) . . . . . 1163<sup>a</sup>  
 of Gilgal . . . . . 1231<sup>a</sup> (Wright)
- Galilean  
 of Galilee . . . . . 1163<sup>a</sup> (Ewing)
- Galilee . . . . . 1163<sup>a</sup> (Ewing)  
 Ancient boundaries . . . . . 1163<sup>a</sup>  
 of Asher . . . . . 268<sup>b</sup> (Ewing)  
 Description of . . . . . 1164<sup>b</sup>  
 of Galilee, Sea of . . . . . 1165<sup>a</sup> (Ewing)  
 of Issachar . . . . . 1541<sup>b</sup> (Ewing)  
 of Naphtali . . . . . 2118<sup>b</sup> (Ewing)  
 In NT times . . . . . 1164<sup>a</sup>  
 In OT times . . . . . 1163<sup>b</sup>  
 of Palestine . . . . . 2221<sup>a</sup> (Conder)  
 Population . . . . . 1165<sup>a</sup>  
 Products of . . . . . 1164<sup>b</sup>  
 Zebulun and Naphtali 1163<sup>a</sup>
- Galilee, Mountain in . . . . . 1165<sup>a</sup>
- Galilee, Sea of . . . . . 1165<sup>a</sup> (Ewing)  
 of Capernaum . . . . . 566<sup>b</sup> (Ewing)  
 Description of . . . . . 1165<sup>b</sup>  
 Fish in . . . . . 1166<sup>b</sup>  
 of Fishing . . . . . 1116<sup>a</sup> (Patch)  
 of Galilee . . . . . 1163<sup>a</sup> (Ewing)  
 of Gennesaret, Land of 1214<sup>b</sup> (Ewing)

- Galilee, Sea of—*continued*  
 of Jordan . . . . . 1733<sup>a</sup> (Wright)  
 Storms on . . . . . 1166<sup>a</sup>  
 Gall . . . . . 1166<sup>b</sup> (Masterman)  
 Gallant . . . . . 1167<sup>a</sup>  
 of Ships and Boats . . . . . 2774<sup>a</sup> (Nicol)  
 Gallery . . . . . 1167<sup>a</sup> (N. Isaacs)  
 of Palestine . . . . . 2218<sup>b</sup> (Conder)  
 of Temple . . . . . 2935<sup>b</sup> (Caldecott; Orr)  
 Galley  
 of Ships and Boats . . . . . 2774<sup>a</sup> (Nicol)  
 Gallim . . . . . 1167<sup>b</sup> (Masterman)  
 Gallio . . . . . 1167<sup>b</sup> (Kerr)  
 of Felix Antonius . . . . . 1105<sup>b</sup> (Kerr)  
 of Festus, Porcius . . . . . 1107<sup>a</sup> (Kerr)  
 of Lysias . . . . . 1943<sup>b</sup> (Hutchison)  
 Gallows  
 of Hanging . . . . . 1335<sup>b</sup> (Hirsch)  
 of Punishments . . . . . 2504<sup>b</sup> (Hirsch)  
 Gamael (Apoc) . . . . . 1168<sup>a</sup>  
 Gamaliel . . . . . 1168<sup>a</sup> (Kerr)  
 of Theudas . . . . . 2972<sup>a</sup> (Kerr)  
 Game . . . . . 1123<sup>b</sup> (Eager)  
 Games . . . . . 1168<sup>b</sup> (Smith)  
 Archery . . . . . 1169<sup>a</sup>  
 Beast fighting . . . . . 1172<sup>a</sup>  
 For children . . . . . 1168<sup>b</sup>  
 Dancing . . . . . 1169<sup>b</sup>  
 Dice . . . . . 1169<sup>a</sup>  
 of Discus . . . . . 854<sup>a</sup> (W. L. Walker)  
 of Ecclesiastes . . . . . 894<sup>b</sup> (Beecher)  
 of Ecclesiasticus . . . . . 2806<sup>b</sup> (T. W. Davies)  
 Of Greece and Rome . . . . . 1171<sup>a</sup>  
 of Herald . . . . . 1375<sup>a</sup>  
 Proverbs . . . . . 1170<sup>a</sup>  
 of Proverbs, Book of . . . . . 2471<sup>b</sup> (Genung)  
 Racing . . . . . 1172<sup>b</sup>  
 Riddles . . . . . 1170<sup>b</sup>  
 of Tale . . . . . 2904<sup>a</sup> (T. Lewis)  
 Gammadim . . . . . 1173<sup>b</sup>  
 Gamul . . . . . 1173<sup>b</sup>  
 Gangrene . . . . . 1173<sup>b</sup> (Macalister)  
 Gap . . . . . 1173<sup>b</sup>  
 Gar . . . . . 1174<sup>a</sup>  
 of Gas . . . . . 1175<sup>b</sup>  
 Garden . . . . . 1174<sup>a</sup> (Patch)  
 of Irrigation . . . . . 1492<sup>b</sup> (Patch)  
 of Jerusalem . . . . . 1603<sup>a</sup> (Masterman)  
 of Paradise . . . . . 2246<sup>a</sup> (Wright)  
 Garden of Gethsemane  
 of Olives, Mount of . . . . . 2187<sup>b</sup> (Masterman)  
 Garden, The King's . . . . . 1175<sup>a</sup> (Orr)  
 of Jerusalem . . . . . 1595<sup>b</sup> (Masterman)  
 Garden-house . . . . . 1175<sup>a</sup>  
 of Beth-haggan . . . . . 445<sup>b</sup>  
 of En-gannim . . . . . 945<sup>a</sup> (Ewing)  
 Gardener . . . . . 1175<sup>a</sup>  
 of Watchman . . . . . 3074<sup>a</sup> (Christie)  
 Gareb . . . . . 1175<sup>a</sup>  
 of Gibeath . . . . . 1225<sup>b</sup> (Ewing)  
 of Ira . . . . . 1491<sup>a</sup> (Farr)  
 Gareb, Hill of . . . . . 1175<sup>a</sup> (Masterman)
- Garizim  
 of Gerizim, Mount . . . . . 1218<sup>a</sup> (Ewing)  
 Garland . . . . . 1175<sup>a</sup> (Doolan)  
 of Crown . . . . . 762<sup>a</sup> (Raffety)  
 Garlic . . . . . 1175<sup>b</sup> (Masterman); 1122<sup>a</sup>  
 (Eager)  
 Garment  
 of Dress . . . . . 875<sup>b</sup> (Eager)  
 Garmite . . . . . 1175<sup>b</sup>  
 of Keilah . . . . . 1791<sup>a</sup> (Masterman)  
 Garner . . . . . 1175<sup>b</sup>  
 Garnish . . . . . 1175<sup>b</sup> (Reeve)  
 Garrison  
 of War . . . . . 3069<sup>b</sup> (Nicol)  
 Gas . . . . . 1175<sup>b</sup>  
 Gashmu . . . . . 1175<sup>b</sup>  
 of Geshem . . . . . 1219<sup>b</sup> (Reeve)  
 Gatam . . . . . 1175<sup>b</sup>  
 Gate . . . . . 1175<sup>b</sup> (Easton)  
 of City . . . . . 662<sup>a</sup> (A. C. Dickie)  
 of Fortification . . . . . 1138<sup>a</sup> (Nicol)  
 of Jerusalem . . . . . 1606<sup>b</sup> (Masterman)  
 of Lift . . . . . 1890<sup>b</sup> (Easton)  
 of Tabernacle . . . . . 2887<sup>b</sup> (Caldecott; Orr)  
 of Temple . . . . . 2930<sup>a</sup> (Caldecott; Orr)  
 Gate, The Beautiful . . . . . 1176<sup>b</sup> (Caldecott)  
 of Gate, East . . . . . 1176<sup>b</sup> (Caldecott)  
 of Temple . . . . . 2937<sup>b</sup> (Caldecott; Orr)  
 Gate, Corner . . . . . 1176<sup>a</sup>  
 of Jerusalem . . . . . 1606<sup>a</sup> (Masterman)  
 Gate, East . . . . . 1176<sup>b</sup> (Caldecott)  
 of Gate, The Beautiful . . . . . 1176<sup>b</sup> (Caldecott)  
 of Harsith . . . . . 1341<sup>a</sup>  
 of Shecaniah . . . . . 2754<sup>b</sup> (Wolf)  
 of Tabernacle . . . . . 2887<sup>b</sup> (Caldecott; Orr)  
 Gate, Fountain  
 of Jerusalem . . . . . 1606<sup>b</sup> (Masterman)  
 Gate of Hammiphkad  
 of Jerusalem Gates . . . . . 1602<sup>b</sup> (Masterman)  
 Gate, Horse  
 of Jerusalem . . . . . 1607<sup>a</sup> (Masterman)  
 Gate, Sur  
 of Jerusalem . . . . . 1606<sup>a</sup> (Masterman)  
 Gate, Valley . . . . . 1177<sup>a</sup>  
 of Jerusalem . . . . . 1607<sup>b</sup> (Masterman)  
 Gath . . . . . 1177<sup>a</sup> (Porter)  
 of Palestine, Recent  
 Exploration . . . . . 2227<sup>a</sup> (Cobern)  
 of Wine . . . . . 3086<sup>b</sup> (Easton)  
 Gather . . . . . 1177<sup>b</sup> (W. L. Walker)  
 Gatherer, Gathering . . . . . 1177<sup>b</sup> (W. L. Walker)  
 Gath-hepher . . . . . 1178<sup>a</sup> (Ewing)  
 Gath-rimmon . . . . . 1178<sup>a</sup> (Ewing)  
 of Ibleam . . . . . 1446<sup>a</sup> (Ewing)  
 Gaulonitis . . . . . 1178<sup>a</sup>  
 of Golan . . . . . 1273<sup>b</sup> (Ewing)  
 Gauls . . . . . 1178<sup>a</sup> (Hutchison)  
 Gaza . . . . . 1178<sup>b</sup> (Porter)  
 of Azzah . . . . . 345<sup>b</sup>  
 of Gazathites (Gazites) . . . . . 1179<sup>a</sup>  
 Gazar (Gezer) . . . . . 1222<sup>b</sup> (Masterman)

- Gazara (Gazzam).....1179<sup>a</sup> (Ewing)  
 of Gazera.....1179<sup>b</sup>  
 of Gezer.....1222<sup>a</sup> (Masterman)
- Gazathites (Gazites).....1179<sup>a</sup>  
 of Gaza.....1178<sup>b</sup> (Porter)
- Gazelle.....1179<sup>a</sup> (Day)  
 of Deer.....817<sup>a</sup> (Day)  
 of Goat.....1248<sup>b</sup> (Day)  
 of Roe, Roebuck.....2597<sup>a</sup> (Day)  
 of Zoölogy.....3155<sup>a</sup> (Day)
- Gazer.....1179<sup>b</sup>  
 of Gezer.....1222<sup>a</sup> (Masterman)
- Gazera.....1179<sup>b</sup>  
 of Gazara.....1179<sup>a</sup> (Ewing)
- Gazez.....1179<sup>b</sup>
- Gazing-stock.....1179<sup>b</sup> (W. L. Walker)
- Gazites (Gazathites).....1179<sup>a</sup>
- Gazzam (Gazara).....1180<sup>a</sup>
- Geba.....1180<sup>a</sup> (Ewing)  
 of Gibeah.....1225<sup>a</sup> (Ewing)
- Gebal.....1180<sup>a</sup> (Porter)  
 of Gebalites.....1180<sup>b</sup> (Hovey)  
 of Mason.....2007<sup>a</sup>  
 of Tammuz.....2908<sup>a</sup> (Porter)
- Gebalites.....1180<sup>a</sup>  
 of Gebal.....1180<sup>a</sup> (Porter)
- Geber (Ben-geber).....1180<sup>b</sup> (Downer)
- Gebim.....1180<sup>b</sup>
- Gecko.....1181<sup>a</sup>  
 of Ferret.....1106<sup>b</sup> (Day)  
 of Lizard.....1906<sup>a</sup> (Day)  
 of Spider.....2840<sup>b</sup> (Day)
- Gedaliah.....1181<sup>a</sup> (Crichton)  
 of Governor of Judah. 574<sup>a</sup> (Nicol)  
 of Ishmael.....1510<sup>b</sup> (Baur)
- Geddur.....1181<sup>b</sup>  
 of Gahar.....1153<sup>b</sup>
- Gedeon  
 of Gideon.....1226<sup>b</sup> (Schenk)
- Geder.....1181<sup>b</sup>
- Gederah, Gederathite.....1181<sup>b</sup>  
 of Gederothaim.....1182<sup>a</sup>  
 of Hedge.....1366<sup>b</sup> (Masterman)
- Gederite  
 of Geder.....1181<sup>b</sup>
- Gederoth.....1181<sup>b</sup> (Ewing)
- Gederothaim.....1182<sup>a</sup>  
 of Gederah.....1181<sup>b</sup>
- Gedor.....1181<sup>a</sup> (Ewing)  
 of Simeon.....2794<sup>a</sup> (Masterman)
- Geese.....1124<sup>a</sup> (Eager)
- Ge-harashim.....1182<sup>a</sup>  
 of Joab.....1677<sup>b</sup> (Roberts)
- Gehazi.....1182<sup>a</sup> (Crichton)
- Gehenna.....1183<sup>a</sup> (Vos)  
 of Eschatology of the  
 NT.....979<sup>b</sup> (Vos)  
 of Hell.....1371<sup>a</sup> (Orr)  
 of Hinnom, Valley of. 1393<sup>b</sup> (Masterman)  
 of Jehoshaphat, Valley  
 of.....1583<sup>a</sup> (Masterman)  
 of Kidron, The Brook. 1798<sup>a</sup> (Masterman)
- Geliloth.....1183<sup>a</sup> (Ewing)
- Gem.....1183<sup>a</sup>  
 of Stones, Precious.....2856<sup>a</sup> (Fletcher)
- Gemalli.....1183<sup>b</sup>
- Gemara  
 of Talmud.....2904<sup>b</sup> (Strack)
- Gemariah.....1183<sup>b</sup>
- Gematria  
 of Games.....1170<sup>b</sup> (Smith)  
 of Number.....2162<sup>b</sup> (Smith)
- Gender.....1183<sup>b</sup> (W. L. Walker)
- Genealogy.....1183<sup>b</sup> (Crannell)  
 of Abiud.....13<sup>b</sup>  
 of Genealogy of Jesus  
 Christ.....1196<sup>a</sup> (Sweet)  
 Interpretation.....1184<sup>b</sup>  
 List in 1 Chronicles.....1191<sup>b</sup>  
 List in Exodus.....1189<sup>a</sup>  
 List in Ezra.....1195<sup>a</sup>  
 List in Genesis.....1186<sup>a</sup>  
 List in 1 Kings.....1191<sup>b</sup>  
 List in Luke.....1195<sup>b</sup>  
 List in Matthew.....1195<sup>b</sup>  
 List in Nehemiah.....1195<sup>b</sup>  
 List in Numbers.....1189<sup>a</sup>  
 List in Ruth.....1190<sup>b</sup>  
 List in 2 Samuel.....1190<sup>b</sup>  
 of Patriarch.....2264<sup>a</sup> (Orr)  
 of Pentateuch.....2309<sup>b</sup> (Wiener)  
 Principles.....1183<sup>b</sup>  
 of Shuthelah, Shuthela-  
 hites.....2783<sup>a</sup>  
 Trustworthiness.....1184<sup>a</sup>
- Genealogy of Jesus  
 Christ.....1196<sup>a</sup> (Sweet)  
 Comparison of ac-  
 counts.....1197<sup>b</sup>  
 Importance of.....1196<sup>a</sup>  
 of Jesus Christ.....1634<sup>a</sup> (Orr)  
 In Luke.....1197<sup>a</sup>  
 In Matthew.....1196<sup>b</sup>  
 And the Virgin-birth. 1198<sup>a</sup>  
 of Virgin-birth.....3052<sup>a</sup>; 3054<sup>a</sup> (Sweet)
- General, Generally.....1199<sup>a</sup> (W. L. Walker)
- Generation.....1199<sup>a</sup> (Crannell)
- Genesis.....1199<sup>b</sup> (Möller)  
 Abraham, family of...1207<sup>a</sup>  
 Contents and connec-  
 tion.....1200<sup>a</sup>  
 Critical theory.....1201<sup>a</sup>  
 of Day of Atonement. 324<sup>b</sup> (Möller)  
 The Divine names...1203<sup>b</sup>  
 Divisions.....1206<sup>a</sup>  
 Early traditions of...1211<sup>a</sup> •  
 Esau, family of.....1208<sup>b</sup>  
 of Exodus, Book of...1056<sup>b</sup> (Möller)  
 of Ezekiel.....1071<sup>a</sup> (Möller)  
 Historicity.....1209<sup>b</sup>  
 Isaac, family of.....1208<sup>a</sup>  
 Jacob, family of.....1208<sup>b</sup>  
 of Leviticus.....1871<sup>b</sup> (Möller)

- Genesis—*continued*  
 Mosaic authorship af-  
   firmed . . . . . 1212<sup>a</sup>  
 Noah, family of . . . . . 1206<sup>b</sup>  
 of Pentateuch . . . . . 2304<sup>b</sup> (Wiener)  
 Rejection of docu-  
   mentary theory . . . . . 1202<sup>a</sup>  
 Unity of plan . . . . . 1200<sup>b</sup>  
 Value of . . . . . 1213<sup>b</sup>  
 Geneva Bible . . . . . 949<sup>b</sup> (Hutchison)  
 Gennaëus (Genneus) . . . . . 1214<sup>b</sup>  
   of Apolloniüs . . . . . 200<sup>b</sup> (Hutchison)  
 Gennesaret, Lake of  
   of Galilee, Sea of . . . . . 1165<sup>a</sup> (Ewing)  
 Gennesaret, Land of . . . . . 1214<sup>b</sup> (Ewing)  
   of Galilee, Sea of . . . . . 1165<sup>a</sup> (Ewing)  
 Gentiles . . . . . 1215<sup>a</sup> (Porter)  
   of Grecians . . . . . 1295<sup>a</sup> (Heidel)  
   of Stranger and So-  
     journer, in OT . . . . . 2865<sup>a</sup> (Wiener)  
 Gentiles, Court of  
   of Temple . . . . . 2930<sup>a</sup> (Caldecott; Orr)  
 Gentiles, Isles of the . . . . . 1511<sup>b</sup>  
 Gentleness, Gentle . . . . . 1215<sup>b</sup> (W. L. Walker)  
   of Kindness . . . . . 1799<sup>a</sup> (W. L. Walker)  
 Genubath . . . . . 1215<sup>b</sup>  
 Geography  
   of Island . . . . . 1511<sup>a</sup> (Day)  
   of Negeb . . . . . 2130<sup>a</sup> (Masterman)  
   of Palestine . . . . . 2208<sup>b</sup> (Conder)  
   of Table of Nations . . . . . 2898<sup>b</sup> (Pinches)  
   of World, Cosmological . . . . . 3106<sup>a</sup> (Orr)  
 Geology of Palestine . . . . . 1215<sup>b</sup> (Day)  
   of Jerusalem . . . . . 1596<sup>b</sup> (Masterman)  
   of Jordan Valley . . . . . 1735<sup>a</sup> (Wright)  
   of Palestine . . . . . 2209<sup>a</sup> (Conder)  
   of Rock . . . . . 2596<sup>a</sup> (Day)  
 Geon  
   of Gihon . . . . . 1228<sup>b</sup> (Masterman)  
 Georgian Versions  
   of Versions, Georgian . . . . . 3048<sup>a</sup> (Easton)  
 Gephyrun . . . . . 1217<sup>a</sup>  
   of Ephron . . . . . 964<sup>a</sup> (Masterman)  
 Gera . . . . . 1217<sup>a</sup>  
 Gerah . . . . . 1217<sup>b</sup>  
   of Weights and Meas-  
     ures . . . . . 3079<sup>a</sup> (Porter)  
 Gerar . . . . . 1217<sup>b</sup> (Porter)  
 Gerasa, Gerasenes . . . . . 1217<sup>b</sup> (Ewing)  
   of Gadara (Gadarenes) . . . . . 1152<sup>b</sup> (Ewing)  
   of Ramoth-gilead . . . . . 2529<sup>a</sup> (Ewing)  
 Gergesenes . . . . . 1218<sup>a</sup>  
   of Gadara (Gadarenes) . . . . . 1152<sup>b</sup> (Ewing)  
 Gerizim, Mount . . . . . 1218<sup>a</sup> (Ewing)  
   of Jerusalem Hills . . . . . 1599<sup>b</sup> (Masterman)  
   of Moriah, Land of . . . . . 2082<sup>b</sup> (Ewing)  
   of Samaritans . . . . . 2673<sup>b</sup> (Ewing)  
 Geron . . . . . 1219<sup>a</sup>  
 Gerrenians . . . . . 1219<sup>a</sup> (Hutchison)  
 Gershom . . . . . 1219<sup>a</sup> (E. D. Isaacs)  
 Gershon, Gershonites . . . . . 1219<sup>a</sup> (E. D. Isaacs)  
 Gerson (Gershom) . . . . . 1219<sup>b</sup>  
 Geruth Chimham . . . . . 1219<sup>b</sup>  
 Gerzites  
   of Girzites (Gizrites) . . . . . 1233<sup>a</sup>  
 Geshan . . . . . 1219<sup>b</sup>  
 Geshem . . . . . 1219<sup>b</sup> (Reeve)  
 Geshur . . . . . 1219<sup>b</sup> (Ewing)  
 Geshurites  
   of Geshur . . . . . 1219<sup>b</sup> (Ewing)  
 Gesture . . . . . 1220<sup>a</sup> (W. L. Walker)  
   of Attitudes . . . . . 329<sup>a</sup> (W. W. Davies)  
 Get, Getting . . . . . 1221<sup>a</sup> (W. L. Walker)  
 Gether . . . . . 1221<sup>b</sup>  
 Gethsemane . . . . . 1221<sup>b</sup> (Masterman)  
   of Temptation of  
     Christ . . . . . 2943<sup>a</sup> (Anderson)  
 Geuel . . . . . 1222<sup>a</sup>  
 Gezer . . . . . 1222<sup>a</sup> (Masterman)  
   of Asherah . . . . . 268<sup>b</sup> (Sayce)  
   of Baal . . . . . 345<sup>a</sup> (Sayce)  
   of Fortification . . . . . 1137<sup>a</sup> (Nicol)  
   of Gazara . . . . . 1179<sup>a</sup> (Ewing)  
   of High Place . . . . . 1390<sup>a</sup> (Easton)  
   of Houses at . . . . . 1434<sup>b</sup> (A. C. Dickie)  
   of Jerusalem . . . . . 1597<sup>b</sup>; 1608<sup>a</sup> (Masterman)  
   of Palestine, Recent  
     Exploration . . . . . 2231<sup>b</sup> (Cobern)  
   of Pillar . . . . . 2398<sup>b</sup> (Orr)  
   of Segub . . . . . 2713<sup>a</sup> (Wolf)  
   of Siloam . . . . . 2791<sup>a</sup> (Masterman)  
   of Zion . . . . . 3150<sup>b</sup> (Masterman)  
 Gezrites  
   of Girzites (Gizrites) . . . . . 1233<sup>a</sup>  
 Ghost . . . . . 1224<sup>a</sup> (W. L. Walker)  
   of Holy Spirit . . . . . 1406<sup>a</sup> (Mullins)  
   of Spirit . . . . . 2841<sup>b</sup> (Marais)  
 Giah . . . . . 1224<sup>b</sup>  
 Giants . . . . . 1224<sup>b</sup> (Orr)  
   of Antediluvians . . . . . 139<sup>a</sup> (Davis)  
   of Sons of God . . . . . 2835<sup>a</sup> (Crichton)  
 Giants, Valley of the  
   of Rephaim, Vale of . . . . . 2560<sup>a</sup> (Ewing)  
 Gibbar . . . . . 1224<sup>b</sup>  
   of Gibeon . . . . . 1225<sup>b</sup> (Ewing)  
 Gibbethon . . . . . 1224<sup>b</sup> (Ewing)  
 Gibeah . . . . . 1224<sup>b</sup>  
   of Gibeah . . . . . 1225<sup>a</sup> (Ewing)  
   of Geba . . . . . 1180<sup>a</sup> (Ewing)  
   of Gibeath . . . . . 1225<sup>b</sup> (Ewing)  
   of Hill, Hill Country . . . . . 1392<sup>a</sup> (Masterman)  
   of Saul . . . . . 2697<sup>b</sup> (Weir)  
 Gibeath . . . . . 1225<sup>b</sup> (Ewing).  
   of Ammah . . . . . 117<sup>a</sup>  
   of Gareb . . . . . 1175<sup>a</sup>  
   of Gibeah . . . . . 1225<sup>a</sup> (Ewing)  
   of Hachilah . . . . . 1313<sup>b</sup>  
   of Moreh . . . . . 2082<sup>a</sup> (Ewing)  
   of Tabor . . . . . 2901<sup>a</sup> (Ewing)  
 Gibeathite  
   of Shemaah . . . . . 2759<sup>b</sup>  
 Gibeon . . . . . 1225<sup>b</sup> (Ewing)  
   of Gibbar . . . . . 1224<sup>b</sup>  
   of Helkath-hazzurim . . . . . 1370<sup>b</sup> (Ewing)

- Gibeon—*continued*  
 of Joshua . . . . . 1746<sup>a</sup> (Roberts)  
 Gibeonites . . . . . 1226<sup>b</sup>  
 of Gibeon . . . . . 1225<sup>b</sup> (Ewing)  
 Giblites (Gebalites) . . . . . 1180<sup>a</sup>  
 of Geba . . . . . 1180<sup>a</sup> (Ewing)  
 Giddalti . . . . . 1226<sup>b</sup>  
 Giddel (Isdael) . . . . . 1226<sup>b</sup>; 1508<sup>b</sup>  
 Gideon . . . . . 1226<sup>b</sup> (Schenk)  
 Call of . . . . . 1226<sup>b</sup>  
 Defeat of Midianites . . . . . 1227<sup>b</sup>  
 of Jerubbaal . . . . . 1595<sup>a</sup>  
 of Judges, Book of . . . . . 1773<sup>a</sup> (Geden)  
 Making of ephod . . . . . 1228<sup>a</sup>  
 of Palestine . . . . . 2213<sup>b</sup> (Conder)  
 Selection of army . . . . . 1227<sup>a</sup>  
 Gideon . . . . . 1228<sup>a</sup>  
 Gidom . . . . . 1228<sup>a</sup>  
 Gier-eagle . . . . . 1228<sup>a</sup> (Stratton-Porter)  
 Gift . . . . . 1228<sup>a</sup> (W. L. Walker)  
 Gift of Tongues . . . . . 2995<sup>b</sup> (Easton)  
 Gifts of Healing . . . . . 1349<sup>b</sup> (Lambert)  
 of Healing . . . . . 1349<sup>b</sup>  
 Gifts, Spiritual . . . . . 2843<sup>b</sup> (Lambert)  
 Gihon . . . . . 1228<sup>b</sup> (Masterman)  
 of Bethesda . . . . . 444<sup>b</sup> (Masterman)  
 of Fuller's Field . . . . . 1148<sup>b</sup> (Masterman)  
 of Hinnom, Valley of . . . . . 1393<sup>b</sup> (Masterman)  
 of Jerusalem . . . . . 1608<sup>b</sup> (Masterman)  
 of Shihor . . . . . 2768<sup>a</sup> (Kyle)  
 of Siloam . . . . . 2791<sup>a</sup> (Masterman)  
 of Zion . . . . . 3150<sup>b</sup> (Masterman)  
 Gihon (River of Eden) . . . . . 1228<sup>b</sup>  
 of Eden . . . . . 897<sup>b</sup> (Wright)  
 Gilalai . . . . . 1229<sup>b</sup>  
 Gilboa . . . . . 1229<sup>b</sup> (Ewing)  
 Battle of . . . . . 793<sup>b</sup> (Weir)  
 of Gilead . . . . . 1229<sup>b</sup> (Ewing)  
 of Well of Harod . . . . . 1340<sup>b</sup> (Ewing)  
 Gilead, Balm of . . . . . 381<sup>a</sup> (Masterman)  
 Gilead (person) . . . . . 1231<sup>a</sup>  
 Gilead (place) . . . . . 1229<sup>b</sup> (Ewing)  
 Geology . . . . . 1230<sup>a</sup>  
 of Gilboa, Mount . . . . . 1229<sup>b</sup> (Ewing)  
 of Havvoth-jair . . . . . 1345<sup>a</sup> (Ewing)  
 History . . . . . 1230<sup>a</sup>  
 of Jabbok . . . . . 1546<sup>b</sup> (Ewing)  
 Location . . . . . 1230<sup>a</sup>  
 of Peraea . . . . . 2319<sup>b</sup> (Ewing)  
 of Ramoth-gilead . . . . . 2529<sup>a</sup> (Ewing)  
 Gilead, Mount  
 of Gilead (place) . . . . . 1229<sup>b</sup> (Ewing)  
 Gileadites . . . . . 1231<sup>a</sup>  
 Gilgal . . . . . 1231<sup>a</sup> (Wright)  
 of Galgala . . . . . 1163<sup>a</sup>  
 of Gallim . . . . . 1167<sup>b</sup> (Masterman)  
 Giloh . . . . . 1231<sup>b</sup>  
 Gilonite  
 of Giloh . . . . . 1231<sup>b</sup>  
 Gimel . . . . . 1231<sup>b</sup>  
 of Alphabet . . . . . 103<sup>b</sup> (Richardson)  
 Gimzo . . . . . 1231<sup>b</sup>
- Gin . . . . . 1231<sup>b</sup> (Stratton-Porter)  
 of Snare . . . . . 2819<sup>a</sup> (Stratton-Porter)  
 of Trap . . . . . 3007<sup>a</sup> (Stratton-Porter)  
 Ginath . . . . . 1232<sup>a</sup>  
 Ginethoi (Ginnethon) . . . . . 1232<sup>a</sup>  
 Girdle  
 of Armor . . . . . 254<sup>a</sup> (Nicol)  
 of Dress . . . . . 875<sup>b</sup> (Eager)  
 of Priests and Levites . . . . . 2452<sup>a</sup> (Wiener)  
 Girschite . . . . . 1232<sup>a</sup> (Sayce)  
 Girl . . . . . 1232<sup>a</sup>  
 of Daughter . . . . . 790<sup>a</sup> (Pollard)  
 of Maid, Maiden . . . . . 1967<sup>b</sup> (Pollard)  
 Girzites (Gizrites) . . . . . 1233<sup>a</sup>  
 Gishpa . . . . . 1232<sup>a</sup>  
 of Hasupha . . . . . 1343<sup>a</sup>  
 Gittah-hepher . . . . . 1232<sup>a</sup>  
 Gittaim . . . . . 1232<sup>a</sup>  
 Gittites . . . . . 1232<sup>a</sup>  
 Gittith  
 of Music . . . . . 2094<sup>b</sup> (Millar)  
 of Psalms, Book of . . . . . 2487<sup>a</sup> (Sampey)  
 Give . . . . . 1232<sup>b</sup> (W. L. Walker)  
 Gizonite (Gumite) . . . . . 1233<sup>a</sup>  
 Gizrites (Girzites) . . . . . 1233<sup>a</sup>  
 of Gezer . . . . . 1222<sup>a</sup> (Masterman)  
 Glad Tidings . . . . . 1233<sup>a</sup> (W. L. Walker)  
 Glass . . . . . 1233<sup>a</sup> (Porter)  
 of Phoenicia . . . . . 2388<sup>a</sup> (Porter)  
 Glass, Sea of . . . . . 1234<sup>b</sup> (Orr)  
 Gleaning . . . . . 1234<sup>b</sup> (Patch)  
 of Agriculture . . . . . 77<sup>a</sup> (Patch)  
 of Harvest . . . . . 1341<sup>b</sup> (Patch)  
 of Reaping . . . . . 2534<sup>a</sup> (Patch)  
 Glede . . . . . 1234<sup>b</sup>  
 of Hawk . . . . . 1345<sup>a</sup> (Stratton-Porter)  
 Glistening . . . . . 1234<sup>b</sup>  
 Glitter, Glittering . . . . . 1235<sup>a</sup>  
 Glorify . . . . . 1235<sup>a</sup> (Betteridge)  
 of Glory . . . . . 1235<sup>b</sup> (Betteridge)  
 Glorious . . . . . 1235<sup>a</sup> (Betteridge)  
 Glory . . . . . 1235<sup>b</sup> (Betteridge)  
 of Glorify . . . . . 1235<sup>a</sup> (Betteridge)  
 of God . . . . . 1253<sup>b</sup> (Rees)  
 In NT and Apoc . . . . . 1238<sup>b</sup>  
 OT passages . . . . . 1236<sup>b</sup>  
 of Shekinah . . . . . 2758<sup>b</sup>  
 Use of term . . . . . 1236<sup>a</sup>  
 Glowing Sand  
 of Mirage . . . . . 2066<sup>a</sup> (Joy)  
 Glutton, Gluttonous . . . . . 1239<sup>b</sup> (W. L. Walker)  
 Gnash . . . . . 1239<sup>b</sup> (W. L. Walker)  
 Gnat . . . . . 1240<sup>a</sup> (Day)  
 of Flea . . . . . 1118<sup>b</sup> (Day)  
 of Lice . . . . . 1887<sup>a</sup> (Day)  
 of Sand Flies . . . . . 2688<sup>b</sup>  
 Gnosticism . . . . . 1240<sup>a</sup> (Rutherford); 627<sup>a</sup>  
 (Orr)  
 of Aeon . . . . . 65<sup>b</sup> (Kapp)  
 of Bible . . . . . 459<sup>b</sup> (Orr)  
 of Canon of NT . . . . . 563<sup>a</sup> (Riggs)  
 Christian antithesis . . . . . 1244<sup>a</sup>



Gnosticism—*continued*

- Definitions . . . . . 1240<sup>a</sup>  
 cf Fulness . . . . . 1148<sup>b</sup> (Rutherford)  
 Harnack's view . . . . . 1245<sup>a</sup>  
 Influence and growth . . . . . 1245<sup>b</sup>  
 Its sects . . . . . 1246<sup>b</sup>  
 cf Johannine Theology 1697<sup>a</sup> (Law)  
 In Johannine writings 1243<sup>a</sup>  
 In 1 John . . . . . 1713<sup>a</sup> (Law)  
 cf Literature, Sub-  
   apostolic . . . . . 1896<sup>b</sup> (Cowan)  
 Modern forms . . . . . 1247<sup>a</sup>  
 Nature of . . . . . 1241<sup>b</sup>  
 In Pauline writings . . . . . 1242<sup>a</sup>  
 Science . . . . . 2702<sup>b</sup> (Rutherford)  
 cf Simon Magus . . . . . 2797<sup>a</sup> (Rutherford)  
 Sources . . . . . 1241<sup>a</sup>  
 Go . . . . . 1248<sup>a</sup> (W. L. Walker)  
 Goad . . . . . 1248<sup>b</sup> (Patch)  
   cf Prick . . . . . 2439<sup>a</sup> (Edwards)  
 Goah . . . . . 1248<sup>b</sup>  
   cf Jerusalem . . . . . 1595<sup>b</sup> (Masterman)  
 Goat . . . . . 1248<sup>b</sup> (Day)  
   cf Chamois . . . . . 592<sup>b</sup> (Day)  
   cf Deer . . . . . 817<sup>a</sup> (Day)  
   cf Food . . . . . 1123<sup>a</sup> (Eager)  
   cf Gazelle . . . . . 1179<sup>a</sup> (Day)  
   cf Kid . . . . . 1797<sup>b</sup>  
   cf Satyr . . . . . 2697<sup>a</sup> (Day)  
   cf Zoölogy . . . . . 3155<sup>a</sup> (Day)  
 Goat's Hair . . . . . 1249<sup>b</sup>  
   cf Tent . . . . . 2947<sup>b</sup> (Patch)  
 Goatskins . . . . . 1249<sup>b</sup> (Patch)  
   cf Hair . . . . . 1320<sup>a</sup> (Luering)  
   cf Weaving . . . . . 3077<sup>a</sup> (Patch)  
 Gob . . . . . 1250<sup>a</sup>  
 Goblet . . . . . 1250<sup>a</sup>  
 God . . . . . 1250<sup>a</sup> (Rees)  
   cf Almighty . . . . . 100<sup>a</sup>  
   cf Asherah . . . . . 268<sup>b</sup> (Sayce)  
   Attributes of  
     cf Omniscience . . . . . 1128<sup>b</sup> (Hodge)  
     cf Authority of . . . . . 334<sup>b</sup> (Rees)  
     cf Children of . . . . . 608<sup>a</sup> (Rees)  
     Definition of idea . . . . . 1251<sup>a</sup>  
     Ethnic ideas of . . . . . 1252<sup>a</sup>  
     cf Faithfulness of . . . . . 1088<sup>b</sup> (Hodge)  
     cf Father, the . . . . . 1100<sup>b</sup> (Orr)  
     cf Glory . . . . . 1235<sup>b</sup> (Betteridge)  
     cf Holy Spirit . . . . . 1406<sup>a</sup> (Mullins)  
   Idea of, in NT . . . . . 1250<sup>b</sup>; 1260<sup>b</sup>  
     Divine Fatherhood . . . . . 1261<sup>a</sup>  
     God as King . . . . . 1262<sup>b</sup>  
     Metaphysical attri-  
       butes . . . . . 1263<sup>b</sup>  
     Moral attributes . . . . . 1263<sup>a</sup>  
     Unity . . . . . 1264<sup>a</sup>  
   Idea of, in OT . . . . . 1252<sup>b</sup>  
     Course of develop-  
       ment . . . . . 1252<sup>b</sup>  
     Forms of manifesta-  
       tion . . . . . 1253<sup>a</sup>

God—*continued*

- Idea of, in OT—*continued*  
 Names of God . . . . . 1254<sup>a</sup>  
 Post-exilic period . . . . . 1258<sup>b</sup>  
 Pre-prophetic con-  
   ceptions . . . . . 1255<sup>a</sup>  
 Prophetic period . . . . . 1257<sup>a</sup>  
 Image of . . . . . 1264<sup>b</sup> (Orr)  
   cf Anthropology . . . . . 144<sup>b</sup> (Marais)  
   cf Jesus Christ . . . . . 1624<sup>a</sup> (Orr)  
 In Johannine theology 1697<sup>a</sup> (Law)  
 Knowledge of . . . . . 1251<sup>b</sup>  
 Names of . . . . . 1264<sup>b</sup> (Mack)  
   cf Adonai . . . . . 57<sup>a</sup>  
   cf Almighty . . . . . 100<sup>a</sup>  
   cf El-Elohe-Israel . . . . . 927<sup>b</sup> (Mack)  
   Elohim . . . . . 1265<sup>b</sup>  
   cf Genesis . . . . . 1203<sup>b</sup> (Möller)  
   cf Highest . . . . . 1390<sup>a</sup> (W. L. Walker)  
   cf Lord of Hosts . . . . . 1919<sup>a</sup>  
   cf Name . . . . . 2112<sup>a</sup> (W. L. Walker)  
   cf Names, Proper . . . . . 2113<sup>a</sup> (Davis)  
   In NT . . . . . 1267<sup>b</sup>  
   cf Omnipotence . . . . . 2188<sup>b</sup> (Vos)  
   In OT . . . . . 1265<sup>b</sup>  
   cf War, Man of . . . . . 3072<sup>a</sup>  
   cf Zurishaddai . . . . . 3159<sup>b</sup>  
   cf Patience . . . . . 2263<sup>b</sup> (W. L. Walker)  
   cf Pauline Theology . . . . . 2289<sup>a</sup> (Easton)  
   cf Philosophy . . . . . 2384<sup>b</sup> (Rees)  
   cf Self-revelation of . . . . . 692<sup>b</sup> (Tisdall)  
   cf Son of . . . . . 2826<sup>b</sup> (Stalker)  
   cf Trinity . . . . . 3012<sup>a</sup> (Warfield)  
   cf The Unknown . . . . . 3037<sup>b</sup> (Easton)  
   cf Wisdom of . . . . . 3092<sup>a</sup> (Easton)  
   cf Zoroastrianism . . . . . 3157<sup>a</sup> (Easton)  
 Goddess . . . . . 1268<sup>a</sup>  
 Godhead . . . . . 1268<sup>a</sup> (Warfield)  
 Godless . . . . . 1270<sup>a</sup> (W. Evans)  
 Godliness, Godly . . . . . 1270<sup>a</sup> (Orr)  
 Gods . . . . . 1270<sup>b</sup> (Reeve)  
   cf Adrammelech . . . . . 61<sup>b</sup> (Beecher)  
   cf Asherah . . . . . 268<sup>b</sup> (Sayce)  
   cf Ashima . . . . . 269<sup>b</sup> (Sayce)  
   cf Baalzebub . . . . . 348<sup>a</sup>  
   cf Babylonia . . . . . 358<sup>b</sup> (Clay)  
   cf Calf, Golden . . . . . 298<sup>a</sup> (Maunder)  
   cf Chemosh . . . . . 601<sup>a</sup> (Nicol)  
   cf Dagon . . . . . 776<sup>b</sup> (Margolis)  
   cf God, Names of, in  
     Genesis . . . . . 1203<sup>b</sup> (Möller)  
   cf God, Names of, in  
     OT . . . . . 1264<sup>b</sup> (Mack)  
   cf God(s), Strange . . . . . 1272<sup>a</sup> (Betteridge)  
   cf Idolatry . . . . . 1447<sup>b</sup> (Cobern)  
   Meaning in NT . . . . . 1272<sup>a</sup>  
   Meaning in OT . . . . . 1270<sup>b</sup>  
   cf Molech, Moloch . . . . . 2074<sup>a</sup> (Nicol)  
   cf Nergal . . . . . 2134<sup>b</sup>  
   cf Nibhaz . . . . . 2141<sup>a</sup>  
   cf Rimmon . . . . . 2594<sup>a</sup> (N. Isaacs)  
   cf Sons of God, OT . . . . . 2835<sup>a</sup> (Crichton)

Gods—*continued*

- cf Succoth-benoth . . . 2869<sup>a</sup> (Pinches)
- cf Tartak . . . . . 2917<sup>a</sup>
- cf Teraphim . . . . . 1455<sup>a</sup> (Cobern)
- God(s), Strange . . . . . 1272<sup>a</sup> (Betteridge)
- cf Gods . . . . . 1270<sup>b</sup> (Reeve)
- Godspeed . . . . . 1272<sup>b</sup> (W. L. Walker)
- cf Hail (interjection) . . 1319<sup>b</sup>
- Goel . . . . . 1272<sup>b</sup> (Breslich)
- cf Avenge . . . . . 340<sup>a</sup> (Breslich)
- cf Murder . . . . . 2094<sup>a</sup> (Hirsch)
- cf Refuge, Cities of . . . 2545<sup>b</sup> (Ewing)
- cf Revenge, Revenger . 2587<sup>a</sup> (Breslich)
- Gog . . . . . 1273<sup>a</sup> (Reeve)
- cf Magog . . . . . 1965<sup>b</sup>
- Goiim . . . . . 1273<sup>a</sup>
- Going, Goings . . . . . 1273<sup>a</sup> (W. L. Walker)
- Golan, Gaulonitis . . . . 1273<sup>b</sup> (Ewing)
- cf Refuge, Cities of . . . 2545<sup>b</sup> (Ewing)
- Gold . . . . . 1274<sup>a</sup> (Patch)
- cf Metals . . . . . 2044<sup>a</sup> (Patch)
- cf Peacock . . . . . 2294<sup>a</sup> (Stratton-Porter)
- cf Phoenicia . . . . . 2388<sup>b</sup> (Porter)
- Golden Calf . . . . . 1275<sup>a</sup>
- cf Astrology . . . . . 295<sup>b</sup> (Maunder)
- cf Calf, Golden . . . . . 542<sup>b</sup> (Cobern)
- cf Idolatry . . . . . 1447<sup>b</sup> (Cobern)
- Golden Candlestick . . . . 553<sup>a</sup> (Orr)
- Golden City . . . . . 1275<sup>a</sup>
- Golden Number . . . . . 1275<sup>a</sup>
- cf Astronomy . . . . . 300<sup>b</sup> (Maunder)
- Goldsmith . . . . . 1275<sup>a</sup> (Patch)
- cf Crafts . . . . . 734<sup>a</sup> (Patch)
- cf Founder . . . . . 1141<sup>b</sup>
- Golgotha . . . . . 1275<sup>a</sup> (Masterman)
- cf Jerusalem . . . . . 1611<sup>b</sup> (Masterman)
- Meaning . . . . . 1275<sup>a</sup>
- Site . . . . . 1275<sup>b</sup>
- cf Skull . . . . . 2814<sup>b</sup>
- Goliath . . . . . 1276<sup>b</sup> (Reeve)
- cf Elhanan . . . . . 928<sup>a</sup> (Sampey)
- cf Lahmi . . . . . 1821<sup>b</sup>
- Gomer . . . . . 1276<sup>b</sup> (Berry)
- Gomer, Wife of Hosea . . . 1276<sup>b</sup> (Reeve)
- cf Hosea . . . . . 1424<sup>b</sup> (J. Robertson)
- Gomorrhah . . . . . 1277<sup>a</sup> (Wright)
- cf Arabah . . . . . 211<sup>b</sup> (Wright)
- cf Cities of the Plain . . 660<sup>a</sup> (Wright)
- cf Dead Sea . . . . . 801<sup>a</sup> (Wright)
- Good . . . . . 1277<sup>a</sup> (W. L. Walker)
- cf Good, Chief . . . . . 1278<sup>a</sup> (W. L. Walker)
- cf Goodness . . . . . 1279<sup>a</sup> (W. L. Walker)
- Good, Chief . . . . . 1278<sup>a</sup> (W. L. Walker)
- cf Good . . . . . 1277<sup>a</sup> (W. L. Walker)
- Goodliness . . . . . 1278<sup>a</sup>
- Goodly . . . . . 1278<sup>b</sup> (W. L. Walker)
- Goodly Trees . . . . . 1278<sup>b</sup> (Masterman)
- cf Feast of Tabernacles 1103<sup>a</sup> (E. D. Isaacs)
- Goodman . . . . . 1279<sup>a</sup> (Reeve)
- Goodness . . . . . 1279<sup>a</sup> (W. L. Walker)
- cf Good . . . . . 1277<sup>a</sup> (W. L. Walker)

Goodness—*continued*

- cf Good, Chief . . . . . 1278<sup>a</sup> (W. L. Walker)
- cf Kindness . . . . . 1799<sup>a</sup> (W. L. Walker)
- Goods . . . . . 1279<sup>a</sup> (W. L. Walker)
- Gopher Wood . . . . . 1279<sup>b</sup> (Masterman)
- cf Deluge of Noah . . . . 821<sup>b</sup> (Wright)
- Gordon's Calvary
- cf Golgotha . . . . . 1275<sup>b</sup> (Masterman)
- Gore . . . . . 1279<sup>b</sup> (W. L. Walker)
- Gorgeous, Gorgeously . . 1279<sup>b</sup> (W. L. Walker)
- Corget . . . . . 1279<sup>b</sup> (Nicol)
- cf Armor, Arms . . . . . 251<sup>a</sup> (Nicol)
- Gorgias . . . . . 1280<sup>a</sup> (Hutchison)
- Gortyna . . . . . 1280<sup>a</sup>
- cf Crete . . . . . 744<sup>b</sup> (Calder)
- Goshen . . . . . 1280<sup>a</sup> (Conder)
- Character . . . . . 1280<sup>b</sup>
- cf Etham . . . . . 1012<sup>b</sup> (Conder)
- cf Exodus . . . . . 1052<sup>a</sup> (Conder)
- Location . . . . . 1280<sup>a</sup>
- Meaning . . . . . 1280<sup>a</sup>
- cf Pi-hahiroth . . . . . 2396<sup>a</sup> (Kyle)
- cf Pithom . . . . . 2401<sup>b</sup> (Conder)
- cf Raamses, Rameses . . 2520<sup>b</sup> (Conder)
- cf Zoan . . . . . 3153<sup>a</sup> (Conder)
- Gospel . . . . . 1281<sup>a</sup> (Bauslin); 465<sup>b</sup> (Orr)
- cf Jesus Christ . . . . . 1626<sup>a</sup> (Orr)
- cf Johannine Theology 1695<sup>b</sup> (Law)
- cf John, Gospel of . . . . 1720<sup>a</sup> (Iverach)
- cf Literature, Sub-  
apoc. . . . . 1904<sup>a</sup> (Cowan)
- cf Logia . . . . . 1910<sup>a</sup> (Smith)
- cf Matthew, Gospel of 2009<sup>b</sup> (Schodde)
- Gospel according to the  
Hebrews . . . . . 1281<sup>b</sup>
- cf Apocryphal Gospels 195<sup>a</sup> (Hutchison)
- cf Matthew, Gospel of 2010<sup>b</sup> (Schodde)
- Gospel of Infancy
- cf Apocryphal Gospels 195<sup>a</sup> (Hutchison)
- Gospels of the Childhood 1281<sup>b</sup>
- cf Apocryphal Gospels 195<sup>a</sup> (Hutchison)
- Gospels, Spurious . . . . . 1281<sup>b</sup>
- cf Apocryphal Gospels 195<sup>a</sup> (Hutchison)
- Gospels, The Synoptic . . 1281<sup>b</sup> (Iverach)
- cf Bible . . . . . 459<sup>b</sup> (Orr)
- cf Canon of NT . . . . . 563<sup>a</sup> (Riggs)
- cf Chronology of NT . . 644<sup>b</sup> (Armstrong)
- Dates . . . . . 1284<sup>a</sup>
- Ethics of Jesus in . . . . 1285<sup>b</sup>
- Influence of oral in-  
struction
- cf Catechist . . . . . 582<sup>b</sup> (Gerberding)
- Jesus as a thinker in . . 1286<sup>a</sup>
- cf Jesus Christ . . . . . 1626<sup>b</sup> (Orr)
- cf Johannine Theology 1695<sup>b</sup> (Law)
- cf John, Gospel of . . . . 1720<sup>a</sup> (Iverach)
- cf Justification in . . . . 1785<sup>a</sup> (Faulkner)
- cf Kingdom of God in . . 1805<sup>a</sup> (Stalker)
- cf Luke, Gospel of . . . . 1938<sup>a</sup> (A. T. Robertson)
- cf Matthew, Gospel of 2011<sup>b</sup> (Schodde)
- Meaning of term . . . . . 1281<sup>b</sup>
- Messianic hope . . . . . 1285<sup>a</sup>

- Gospels, The Synoptic—*continued*  
 Messianic idea . . . . .1284<sup>b</sup>  
 Oral tradition . . . . .1283<sup>a</sup>  
 Order of events . . . . .1283<sup>b</sup>  
 of Person of Christ . . . . .2344<sup>a</sup> (Warfield)  
 Problem of sources . . . . .1282<sup>a</sup>  
 Purpose of . . . . .1286<sup>a</sup>  
 of Relation to Fourth  
 Gospel . . . . .1722<sup>b</sup> (Iverach)  
 Relation of OT to . . . . .1285<sup>b</sup>.  
 Time  
 of Chronology of NT 644<sup>b</sup> (Armstrong)  
 of Jesus Christ . . . . .1626<sup>b</sup> (Orr)  
 Gothic Version . . . . .3048<sup>a</sup> (Easton)  
 Gotholias . . . . .1286<sup>b</sup>  
 Gothoniel . . . . .1286<sup>b</sup>  
 Gourd . . . . .1286<sup>b</sup> (Masterman)  
 Gourd, Wild . . . . .1286<sup>b</sup> (Masterman)  
 Government . . . . .1287<sup>a</sup> (Heidel)  
 Fiscal institutions . . . . .1288<sup>b</sup>  
 Greek  
 of Asmoneans . . . . .283<sup>a</sup> (Dosker)  
 Later code  
 of Deuteronomy . . . . .835<sup>b</sup> (Robinson)  
 Later periods . . . . .1289<sup>a</sup>  
 Nomadic period . . . . .1287<sup>a</sup>  
 Period of judges . . . . .1287<sup>b</sup>  
 Period of the mon-  
 archy . . . . .1288<sup>a</sup>  
 of Presbyter . . . . .2437<sup>b</sup> (Mack)  
 Roman  
 of Governor . . . . .1289<sup>b</sup> (Heidel)  
 of Senate, Senator . . . . .2719<sup>b</sup> (Heidel)  
 Governor . . . . .1289<sup>b</sup> (Heidel)  
 of Felix Antonius . . . . .1105<sup>b</sup> (Kerr)  
 of Festus, Porcius . . . . .1107<sup>a</sup> (Kerr)  
 of Government . . . . .1289<sup>a</sup> (Heidel)  
 In NT . . . . .1289<sup>b</sup>  
 In OT . . . . .1289<sup>b</sup>  
 of Pilate . . . . .2396<sup>a</sup> (J. M. Wilson)  
 of Prince . . . . .2453<sup>a</sup> (Baur)  
 of Procurator . . . . .2457<sup>b</sup> (Allen)  
 of Tirshatha . . . . .2986<sup>b</sup> (R. D. Wilson)  
 Goyim  
 of Goiim . . . . .1273<sup>a</sup>  
 Gozan . . . . .1290<sup>a</sup> (Orr)  
 of Habor . . . . .1313<sup>b</sup> (Pinches)  
 of Halah . . . . .1321<sup>b</sup> (Pinches)  
 Graba  
 of Aggaba . . . . .71<sup>b</sup>  
 Grace . . . . .1290<sup>a</sup> (Easton)  
 of Holy Spirit . . . . .1406<sup>a</sup> (Mullins)  
 In Justification . . . . .1291<sup>a</sup>  
 of Justification . . . . .1782<sup>b</sup> (Faulkner)  
 In OT . . . . .1292<sup>a</sup>  
 Other uses . . . . .1291<sup>a</sup>  
 Power . . . . .1290<sup>b</sup>  
 Teaching of Christ . . . . .1291<sup>b</sup>  
 Terms . . . . .1290<sup>a</sup>  
 of Thank, Thanks,  
 Thanksgiving . . . . .2964<sup>b</sup> (Easton)  
 Gracious . . . . .1292<sup>b</sup> (Clippinger)
- Graecia  
 of Greece . . . . .1295<sup>a</sup> (Heidel)  
 Graft . . . . .1292<sup>b</sup> (Patch)  
 Grain  
 of Agriculture . . . . .75<sup>b</sup> (Patch)  
 of Garner . . . . .1175<sup>b</sup>  
 Granary  
 of Garner . . . . .1175<sup>b</sup>  
 of Store-houses . . . . .2863<sup>a</sup>  
 Grapes  
 of Food . . . . .1122<sup>b</sup> (Eager)  
 of Vine . . . . .3049<sup>b</sup> (Masterman)  
 Grapes, Wild . . . . .1293<sup>a</sup>  
 of Vine . . . . .3050<sup>a</sup> (Masterman)  
 Grasp . . . . .1293<sup>a</sup> (Miller)  
 of Prize . . . . .2457<sup>a</sup> (Edwards)  
 of Robber, Robbery . . . . .2595<sup>b</sup> (Easton)  
 Grass . . . . .1293<sup>a</sup> (Masterman)  
 of Herb . . . . .1375<sup>a</sup> (Masterman)  
 Grasshopper  
 of Locust . . . . .1908<sup>a</sup> (Day)  
 Grate, Grating . . . . .1293<sup>b</sup> (Caldecott)  
 Grave  
 of Burial . . . . .529<sup>a</sup> (Eager)  
 Grave (adjective)  
 of Gravity . . . . .1293<sup>b</sup> (W. L. Walker)  
 Grave, Graving  
 of Crafts . . . . .734<sup>a</sup> (Patch)  
 Gravel . . . . .1293<sup>b</sup> (Day)  
 Gravity . . . . .1293<sup>b</sup> (W. L. Walker)  
 Gray  
 of Colors . . . . .674<sup>b</sup> (Patch)  
 Grease . . . . .1294<sup>a</sup>  
 of Fat . . . . .1099<sup>b</sup> (Luering)  
 of Gross . . . . .1307<sup>a</sup>  
 Great, Greatness . . . . .1294<sup>a</sup> (W. L. Walker)  
 Great Bear (Arcturus) . . . . .313<sup>a</sup>  
 Greaves  
 of Armor, Arms . . . . .251<sup>a</sup> (Nicol)  
 Grecians, Greeks . . . . .1294<sup>b</sup> (Heidel)  
 of Gentiles . . . . .1215<sup>a</sup> (Porter)  
 of Hellenism . . . . .1371<sup>a</sup> (Heidel)  
 Greece, Graecia . . . . .1295<sup>a</sup> (Heidel)  
 Climate . . . . .1296<sup>a</sup>  
 The country . . . . .1295<sup>a</sup>  
 of Divination . . . . .860<sup>a</sup> (T. W. Davies)  
 of Dreams . . . . .874<sup>a</sup> (Clippinger)  
 Geology and topog-  
 raphy . . . . .1296<sup>b</sup>  
 of Javan . . . . .1572<sup>a</sup> (Roberts)  
 Greece, Religion in An-  
 cient . . . . .1297<sup>a</sup> (Fairbanks)  
 Divination . . . . .1300<sup>b</sup>  
 of Divination . . . . .860<sup>a</sup> (T. W. Davies)  
 of Dreams . . . . .874<sup>a</sup> (Clippinger)  
 Festivals . . . . .1302<sup>a</sup>  
 Forms of worship . . . . .1301<sup>a</sup>  
 Future life . . . . .1303<sup>a</sup>  
 Gods . . . . .1298<sup>b</sup>  
 Gods of activity and  
 emotions . . . . .1300<sup>a</sup>  
 Gods and Nature . . . . .1299<sup>a</sup>

- Greece, Religion in Ancient—*continued*  
 The Great Gods . . . . . 1299<sup>b</sup>  
 of Hellenism, Hellenist 1371<sup>a</sup> (Heidel)  
 Influence on Christianity . . . . . 1304<sup>b</sup>  
 Local shrines . . . . . 1298<sup>a</sup>  
 Mysteries . . . . . 1303<sup>a</sup>  
 The myths . . . . . 1297<sup>b</sup>  
 Omens, dreams . . . . . 1300<sup>b</sup>  
 Oracles . . . . . 1301<sup>a</sup>  
 Prayer . . . . . 1302<sup>a</sup>  
 Priests . . . . . 1301<sup>b</sup>  
 of Prophecy . . . . . 2466<sup>a</sup> (Orelli)  
 Revelation, inspiration . . . . . 1300<sup>a</sup>  
 of Rome . . . . . 2620<sup>b</sup> (Allen)  
 Sacrifices . . . . . 1302<sup>b</sup>  
 Sin, expiation . . . . . 1304<sup>a</sup>  
 Greece, Sons of . . . . . 1305<sup>a</sup>  
 of Asmodeans . . . . . 283<sup>a</sup> (Dosker)  
 of Javan . . . . . 1572<sup>a</sup> (Roberts)  
 Greek Language  
 of Language of NT . . . 1826<sup>b</sup> (A. T. Robertson)  
 Greek Religion  
 of Greece, Religion in . . 1297<sup>a</sup> (Fairbanks)  
 of Mercury, Mercurius 2035<sup>a</sup> (M. O. Evans)  
 Greek Versions  
 of Septuagint . . . . . 2722<sup>a</sup> (Thackeray)  
 of Versions, Georgian,  
 Gothic, Slavonic . . . 3048<sup>a</sup> (Easton)  
 Greeks  
 of Grecians . . . . . 1294<sup>b</sup> (Heidel)  
 Green, Greenish  
 of Colors . . . . . 674<sup>b</sup> (Patch)  
 Greeting . . . . . 1305<sup>a</sup> (W. L. Walker)  
 of Farewell . . . . . 1098<sup>a</sup> (W. L. Walker)  
 of Hail (interjection) . . 1319<sup>b</sup>  
 of Peace . . . . . 2293<sup>a</sup> (W. L. Walker)  
 Greyhound  
 of Dog . . . . . 867<sup>b</sup> (Day)  
 Grief, Grieve . . . . . 1305<sup>b</sup> (W. L. Walker)  
 Grievance . . . . . 1306<sup>b</sup> (W. L. Walker)  
 Grievous, Grievously,  
 Grievousness . . . . . 1306<sup>b</sup> (W. L. Walker)  
 Grinder  
 of Mill . . . . . 2052<sup>a</sup> (Patch)  
 Grinding  
 of Crafts . . . . . 736<sup>a</sup> (Patch)  
 Grisdled, Grizzled  
 of Colors . . . . . 674<sup>b</sup> (Patch)  
 Groan . . . . . 1306<sup>b</sup> (Macalister)  
 Gross . . . . . 1307<sup>a</sup>  
 of Grease . . . . . 1294<sup>a</sup>  
 Ground, Grounded . . . . 1307<sup>a</sup> (W. L. Walker)  
 of Fallow . . . . . 1094<sup>a</sup>  
 of Parched . . . . . 2247<sup>b</sup> (Patch)  
 Grove . . . . . 1307<sup>b</sup>  
 of Asherah . . . . . 268<sup>b</sup> (Sayce)  
 of Tamarisk . . . . . 507<sup>b</sup> (Masterman)  
 Grudge . . . . . 1307<sup>b</sup> (W. L. Walker)  
 Guard . . . . . 1307<sup>b</sup> (Nicol)  
 of Captain . . . . . 568<sup>b</sup> (Nicol)  
 Guard—*continued*  
 Foreigners as . . . . . 1308<sup>a</sup>  
 of Post . . . . . 2423<sup>a</sup> (M. O. Evans)  
 Royal bodyguards . . . 1308<sup>a</sup>  
 In temple . . . . . 1308<sup>a</sup>  
 Guardian  
 of Angels . . . . . 132<sup>b</sup> (J. M. Wilson)  
 of Family . . . . . 1094<sup>b</sup> (Caverno)  
 Gubarn . . . . . 788<sup>a</sup> (R. D. Wilson)  
 Gudea  
 of Shinar . . . . . 2773<sup>a</sup> (Pinches)  
 Gudgodah . . . . . 1308<sup>a</sup>  
 Guest . . . . . 1308<sup>b</sup> (Clippinger)  
 of Guest-chamber . . . 1308<sup>b</sup> (Estes)  
 of Hospitality . . . . . 1432<sup>a</sup> (Easton)  
 Guest-chamber . . . . . 1308<sup>b</sup> (Estes)  
 of Guest . . . . . 1308<sup>b</sup> (Clippinger)  
 Guide . . . . . 1308<sup>b</sup> (W. L. Walker)  
 Guile . . . . . 1309<sup>a</sup> (W. L. Walker)  
 Guilt . . . . . 1309<sup>a</sup> (Rall)  
 In OT . . . . . 1309<sup>a</sup>  
 of Sin . . . . . 2798<sup>b</sup> (McConnell)  
 In teachings of Jesus . . 1309<sup>b</sup>  
 In teachings of Paul . . 1309<sup>b</sup>  
 Guilt Offering  
 of Sacrifice, OT . . . . . 2645<sup>a</sup> (Reeve)  
 Guiltless . . . . . 1310<sup>a</sup>  
 Guilty . . . . . 1310<sup>a</sup> (Rall)  
 of Guilt . . . . . 1309<sup>a</sup> (Rall)  
 Gulf . . . . . 1310<sup>b</sup> (M. O. Evans)  
 of Abraham's Bosom . . . 22<sup>a</sup> (Orr)  
 of Hades . . . . . 1314<sup>b</sup> (Vos)  
 of Punishment, Ever-  
 lasting . . . . . 2502<sup>b</sup> (Orr)  
 Guni, Gunites . . . . . 1310<sup>b</sup>  
 Gur, The Ascent . . . . . 1310<sup>b</sup>  
 Gur-baal . . . . . 1310<sup>b</sup> (Ewing)  
 Gutter  
 of House . . . . . 1434<sup>b</sup> (A. C. Dickie)  
 Gymnasium  
 of Games . . . . . 1168<sup>b</sup> (Smith)  
 Ha . . . . . 1311<sup>a</sup>  
 of Ah, Aha . . . . . 78<sup>a</sup> (Mack)  
 Haahashtari . . . . . 1311<sup>a</sup>  
 Habaiah (Hobaiah) . . . 1311<sup>a</sup>  
 Habaiah (Obdia) . . . . . 2174<sup>b</sup>  
 Habakkuk . . . . . 1311<sup>a</sup> (Eiselen)  
 Author . . . . . 1311<sup>a</sup>  
 of Bel and the Dragon . 428<sup>b</sup> (T. W. Davies)  
 Book . . . . . 1311<sup>b</sup>  
 Date and occasion . . . 1312<sup>a</sup>  
 Integrity . . . . . 1312<sup>a</sup>  
 Interpretation of chapters 1 and 2 . . . 1311<sup>b</sup>  
 Style . . . . . 1312<sup>a</sup>  
 Teaching . . . . . 1312<sup>b</sup>  
 Habakkuk, Prayer of  
 of Beth-horon, Battle  
 of . . . . . 446<sup>b</sup> (Maunder)  
 Habaziniah (Habazziniah) . . . . . 1313<sup>a</sup>

- Habergeon . . . . . 1313<sup>a</sup>  
 cf Armør, Arms . . . . . 251<sup>a</sup> (Nicol)
- Habiri  
 cf Tell el-Amarna Tablets . . . . . 2927<sup>b</sup> (Kyle)
- Habitation . . . . . 1313<sup>a</sup> (Orr)  
 cf House . . . . . 1434<sup>b</sup> (A. C. Dickie)
- Habor . . . . . 1313<sup>b</sup> (Pinches)  
 cf Gozan . . . . . 1290<sup>a</sup> (Orr)  
 cf Halah . . . . . 1321<sup>b</sup> (Pinches)
- Hacaliah (Hachaliah) . . . . . 1313<sup>b</sup>
- Hachilah . . . . . 1313<sup>b</sup>  
 cf Gibeath . . . . . 1225<sup>b</sup> (Ewing)
- Hachmoni (Hachmonite) . . . . . 1313<sup>b</sup> (Hovey)
- Hadad . . . . . 1313<sup>b</sup> (Hovey); 912<sup>a</sup>  
 (Petrie)
- Hadadezer . . . . . 1314<sup>a</sup> (Nicol)  
 cf Benhadad . . . . . 435<sup>b</sup> (Nicol)
- Hadadrimmon . . . . . 1314<sup>a</sup> (Ewing)  
 cf Adadrimmon . . . . . 48<sup>b</sup>  
 cf Rimmon . . . . . 2594<sup>a</sup> (N. Isaacs)
- Hadar  
 cf Hadad . . . . . 1314<sup>a</sup> (Hovey)
- Hadarezer . . . . . 1314<sup>b</sup>  
 cf Benhadad . . . . . 435<sup>b</sup> (Nicol)  
 cf Hadadezer . . . . . 1314<sup>a</sup> (Nicol)
- Hadashah . . . . . 1314<sup>b</sup>
- Hadassah . . . . . 1314<sup>b</sup>  
 cf Esther . . . . . 1006<sup>a</sup> (Urquhart)
- Hadattah  
 cf Hazor . . . . . 1347<sup>b</sup> (Ewing)
- Hades . . . . . 1314<sup>a</sup> (Vos)  
 cf Abraham's Bosom . . . . . 22<sup>b</sup> (Orr)  
 cf Eschatology of NT . . . . . 979<sup>b</sup> (Vos)  
 cf Gulf . . . . . 1310<sup>b</sup> (M. O. Evans)  
 In NT . . . . . 1314<sup>b</sup>  
 Not a final state . . . . . 1315<sup>b</sup>  
 In OT (Sheol) . . . . . 1314<sup>b</sup>  
 cf Paradise . . . . . 2246<sup>a</sup> (Wright)  
 cf Sheol . . . . . 2761<sup>a</sup> (Orr)  
 cf Spirits in Prison . . . . . 2456<sup>b</sup> (Orr)
- Hadid (Adida) . . . . . 1315<sup>b</sup>  
 cf Adida . . . . . 55<sup>b</sup>  
 cf Zeboim . . . . . 3134<sup>a</sup> (Masterman)
- Hadlai . . . . . 1315<sup>b</sup>
- Hadoram (Joram) . . . . . 1316<sup>a</sup> (Hovey)  
 cf Adoniram . . . . . 58<sup>a</sup> (Beecher)
- Hadrach . . . . . 1316<sup>a</sup>
- Hagab . . . . . 1316<sup>a</sup>
- Hagaba . . . . . 1316<sup>a</sup>  
 cf Accaba . . . . . 27<sup>b</sup>  
 cf Hagabah . . . . . 1316<sup>a</sup>
- Hagabah . . . . . 1316<sup>a</sup>  
 cf Hagaba . . . . . 1316<sup>a</sup>
- Hagar . . . . . 1316<sup>a</sup> (Crichton)  
 Allegorical use by St.  
 Peter . . . . . 1317<sup>a</sup>  
 Allegory of . . . . . 1317<sup>a</sup>  
 Critical points . . . . . 1317<sup>a</sup>  
 Expulsion and Divine  
 help . . . . . 1316<sup>a</sup>
- Hagar—*continued*  
 Flight . . . . . 1316<sup>a</sup>  
 Ishmael . . . . . 1509<sup>a</sup> (Baur)  
 Practical lessons . . . . . 1316<sup>b</sup>  
 cf Sarah . . . . . 2691<sup>a</sup> (Boyd)  
 Vision and return . . . . . 1316<sup>a</sup>
- Hagarenes  
 cf Agarenes . . . . . 70<sup>b</sup>  
 cf Hagrites . . . . . 1319<sup>a</sup> (Mack)
- Hagarites (Hagarenes)  
 cf Hagrites . . . . . 1319<sup>a</sup> (Mack)
- Hagerite  
 cf Hagrites . . . . . 1319<sup>a</sup> (Mack)
- Haggada  
 cf Talmud . . . . . 2904<sup>b</sup> (Strack)
- Haggai . . . . . 1317<sup>a</sup> (Robinson)  
 Analysis of work . . . . . 1318<sup>a</sup>  
 Book of . . . . . 1318<sup>a</sup>  
 Contribution to prophecy—necessity of rebuilding the temple . . . . . 1318<sup>b</sup>  
 Criticism . . . . . 1319<sup>a</sup>  
 cf Joshua (son of Jehozadak) . . . . . 1748<sup>a</sup> (Roberts)  
 Message . . . . . 1318<sup>b</sup>  
 Name . . . . . 1317<sup>b</sup>  
 Period and circumstances . . . . . 1317<sup>b</sup>  
 Personal history . . . . . 1317<sup>b</sup>  
 Preaching of . . . . . 1317<sup>b</sup>  
 Style . . . . . 1318<sup>b</sup>  
 Work . . . . . 1317<sup>b</sup>
- Haggeri . . . . . 1319<sup>a</sup>
- Haggi . . . . . 1319<sup>a</sup>
- Haggiah . . . . . 1319<sup>a</sup>  
 cf Haggi . . . . . 1319<sup>a</sup>
- Haggites . . . . . 1319<sup>a</sup>
- Haggith . . . . . 1319<sup>a</sup>
- Hagia  
 cf Agia . . . . . 71<sup>b</sup>
- Hagiographa  
 cf Bible . . . . . 459<sup>b</sup> (Orr)  
 cf Canon of OT . . . . . 554<sup>a</sup> (Robinson)  
 cf Septuagint . . . . . 2730<sup>b</sup> (Thackeray)
- Hagri . . . . . 1319<sup>a</sup>
- Hagrites . . . . . 1319<sup>a</sup> (Mack)
- Ha-hiroth  
 cf Pi-hahiroth . . . . . 2396<sup>a</sup> (Kyle)
- Hai . . . . . 1319<sup>b</sup>  
 cf Ai . . . . . 87<sup>b</sup> (Mack)
- Hail . . . . . 1319<sup>b</sup> (Joy)  
 cf Lightning . . . . . 1892<sup>b</sup> (Joy)  
 Plague of . . . . . 1319<sup>b</sup>
- Hail (interjection) . . . . . 1319<sup>b</sup>  
 cf Greeting . . . . . 1305<sup>a</sup> (W. L. Walker)
- Hair . . . . . 1320<sup>a</sup> (Luerig)  
 cf Barber . . . . . 403<sup>a</sup> (Eager)  
 cf Camel's Hair . . . . . 548<sup>a</sup> (Patch)  
 Cutting and shaving . . . . . 1320<sup>a</sup>  
 cf Head . . . . . 1348<sup>a</sup> (Luerig)  
 cf Goat's Hair . . . . . 1249<sup>b</sup> (Patch)  
 cf Goatskins . . . . . 1249<sup>b</sup>

- Hair—*continued*  
 Nazirite . . . . . 1320<sup>b</sup>  
 Offerings . . . . . 1320<sup>a</sup>  
 Ointments . . . . . 1321<sup>a</sup>  
 Plucking of the  
 of Punishments . . . . . 2504<sup>b</sup> (Hirsch)  
 of Poll . . . . . 2415<sup>b</sup> (Luering)  
 of Razor . . . . . 2533<sup>b</sup>  
 Symbolical use . . . . . 1321<sup>b</sup>  
 of Washing of Feet . . . . . 3072<sup>a</sup> (Anderson)  
 of Weaving . . . . . 3077<sup>a</sup> (Patch)  
 Ha-jehudijah . . . . . 1321<sup>b</sup>  
 Hakkatan . . . . . 1321<sup>b</sup>  
 of Akatan . . . . . 88<sup>b</sup>  
 Hakkoz . . . . . 1321<sup>b</sup>  
 of Akkos . . . . . 89<sup>a</sup>  
 Hakupha . . . . . 1321<sup>b</sup>  
 of Achipa . . . . . 36<sup>a</sup>  
 Halah . . . . . 1321<sup>b</sup> (Pinches)  
 of Gozan . . . . . 1290<sup>a</sup> (Orr)  
 of Habor . . . . . 1313<sup>b</sup> (Pinches)  
 Halak, Mount . . . . . 1322<sup>a</sup> (Ewing)  
 of Hor, Mount . . . . . 1421<sup>a</sup> (Ewing)  
 Halakha  
 of Talmud . . . . . 2904<sup>b</sup> (Strack)  
 Hale, Haling . . . . . 1322<sup>a</sup>  
 Half  
 of Number . . . . . 2157<sup>a</sup> (Smith)  
 Halhul . . . . . 1322<sup>a</sup> (Masterman)  
 Hali . . . . . 1322<sup>b</sup>  
 Halicarnassus . . . . . 1322<sup>b</sup> (Banks)  
 Hall  
 of House . . . . . 1434<sup>b</sup> (A. C. Dickie)  
 Hall, Judgment . . . . . 1777<sup>b</sup> (Rutherford)  
 Hallel . . . . . 1322<sup>b</sup> (Sampey)  
 Hallelujah . . . . . 1323<sup>a</sup> (Breslich)  
 Hallohesh . . . . . 1323<sup>a</sup>  
 Hallow . . . . . 1323<sup>a</sup> (Crannell)  
 Hallowed (Hallow) . . . . . 1323<sup>a</sup> (Crannell)  
 Halt . . . . . 1323<sup>b</sup> (Orr)  
 Ham (person) . . . . . 1323<sup>b</sup> (Pinches)  
 of Japheth . . . . . 1568<sup>b</sup> (Pinches)  
 of Shem . . . . . 2759<sup>a</sup> (Pinches)  
 of Table of Nations . . . . . 2898<sup>b</sup> (Pinches)  
 Ham (place) . . . . . 1324<sup>a</sup> (Ewing)  
 of Mizraim . . . . . 2069<sup>b</sup> (Kyle)  
 of Shem . . . . . 2759<sup>a</sup> (Pinches)  
 Haman . . . . . 1324<sup>b</sup> (Urquhart)  
 Hamath . . . . . 1324<sup>b</sup> (Christie)  
 Hamath-zobah . . . . . 1325<sup>a</sup> (Christie)  
 Hammath (person) . . . . . 1325<sup>a</sup> (Ewing)  
 Hammath (place) . . . . . 1325<sup>a</sup> (Ewing)  
 Hammeah, Tower of . . . . . 1325<sup>b</sup> (Masterman)  
 of Jerusalem . . . . . 1607<sup>b</sup> (Masterman)  
 Hamedatha . . . . . 1325<sup>b</sup>  
 Hammelech . . . . . 1325<sup>b</sup>  
 Hammer . . . . . 1325<sup>b</sup> (Patch)  
 of Tools . . . . . 2998<sup>b</sup> (Easton)  
 Hammiphkad, The Gate  
 of . . . . . 1325<sup>b</sup>  
 Hammolecheth (Hammoleketh) . . . . . 1325<sup>b</sup>  
 Hammon . . . . . 1325<sup>b</sup> (Ewing)  
 Hammoth-dor . . . . . 1326<sup>a</sup> (Christie)  
 Hammuel . . . . . 1326<sup>a</sup>  
 Hammurabi . . . . . 1326<sup>a</sup> (Pinches); 366<sup>a</sup>  
 (Clay)  
 of Amraphel . . . . . 126<sup>a</sup> (Pinches)  
 of Arioch . . . . . 241<sup>a</sup> (Pinches)  
 Authorship of Deuteronomy . . . . . 840<sup>a</sup>  
 of Chedorlaomer . . . . . 599<sup>a</sup> (Pinches)  
 of Nineveh, Library of . . . . . 2152<sup>a</sup> (Sayce)  
 of Semites, Semitic Religion . . . . . 2717<sup>a</sup> (Mack)  
 of Tidal . . . . . 2980<sup>a</sup> (Pinches)  
 Hammurabi, Code of . . . . . 1327<sup>a</sup> (Ungnad)  
 Comparison with other systems . . . . . 1332<sup>a</sup>  
 Contents . . . . . 1328<sup>a</sup>  
 Discovery of . . . . . 1327<sup>b</sup>  
 Hammurabi and Moses . . . . . 1331<sup>b</sup>  
 The inscription . . . . . 1327<sup>a</sup>  
 of Law in OT . . . . . 1854<sup>a</sup> (Rule)  
 Laws regarding family . . . . . 1330<sup>a</sup>  
 Significance . . . . . 1331<sup>a</sup>  
 Hamonah . . . . . 1332<sup>b</sup>  
 Hamon-gog . . . . . 1332<sup>b</sup>  
 Hamor . . . . . 1332<sup>b</sup> (DeMent)  
 Hamran (Amran) . . . . . 1332<sup>b</sup>  
 of Hemdan . . . . . 1374<sup>b</sup>  
 Hamuel . . . . . 1332<sup>b</sup>  
 of Hammuel . . . . . 1326<sup>a</sup>  
 Hamul . . . . . 1332<sup>b</sup>  
 Hamutal . . . . . 1332<sup>b</sup>  
 Hanamel  
 of Jerusalem . . . . . 1595<sup>b</sup> (Masterman)  
 Hanan . . . . . 1333<sup>a</sup> (DeMent)  
 Hananel, Tower of . . . . . 1333<sup>a</sup> (Masterman)  
 of Jerusalem . . . . . 1603<sup>a</sup> (Masterman)  
 Hanani . . . . . 1333<sup>a</sup> (DeMent)  
 Hananiah . . . . . 1333<sup>b</sup> (Reeve)  
 of Shadrach . . . . . 2746<sup>a</sup> (R. D. Wilson)  
 Hand . . . . . 1333<sup>b</sup> (Luering)  
 of Palm of the . . . . . 2235<sup>a</sup> (Luering)  
 Handbreadth . . . . . 1334<sup>b</sup>  
 of Weights and Measures . . . . . 3079<sup>a</sup> (Porter)  
 Handful . . . . . 1334<sup>b</sup> (Porter)  
 Handicraft  
 of Crafts . . . . . 734<sup>a</sup> (Patch)  
 Handkerchief . . . . . 1334<sup>b</sup>  
 of Dress . . . . . 875<sup>b</sup> (Eager)  
 of Napkin . . . . . 2119<sup>b</sup>  
 Handle . . . . . 1335<sup>a</sup>  
 Handmaid . . . . . 1335<sup>a</sup> (McGlothlin)  
 Hands, Imposition of . . . . . 1335<sup>a</sup> (Orr)  
 of Ministry . . . . . 2057<sup>a</sup> (T. M. Lindsay)  
 of Ordain, Ordination . . . . . 2199<sup>a</sup> (Edwards)  
 of Sacrifice . . . . . 2651<sup>a</sup> (Williams)  
 Hands, Laying on of  
 of Hands, Imposition  
 of . . . . . 1335<sup>a</sup> (Orr)  
 of Lay, Laying . . . . . 1859<sup>b</sup> (Breslich)

- Handstaff . . . . . 1335<sup>b</sup>  
   of Staff . . . . . 2847<sup>b</sup>  
 Handwriting  
   of Manuscripts . . . . . 1984<sup>a</sup> (Richardson)  
   of Writing . . . . . 3114<sup>a</sup> (Richardson)  
 Hanes . . . . . 1335<sup>b</sup> (Kyle)  
 Hanging . . . . . 1335<sup>b</sup> (Hirsch)  
   of Punishments . . . . . 2504<sup>b</sup> (Hirsch)  
 Hangings . . . . . 1335<sup>b</sup> (Downer)  
 Haniel  
   of Hanniel . . . . . 1336<sup>a</sup>  
 Hannah . . . . . 1336<sup>a</sup> (DeMent)  
 Hammathon . . . . . 1336<sup>a</sup>  
 Hanniel . . . . . 1336<sup>a</sup>  
 Hanoah (Hanochites) . . . . . 1336<sup>a</sup>  
   of Henoch . . . . . 1374<sup>b</sup>  
 Hanun . . . . . 1336<sup>b</sup> (DeMent)  
 Hap, Haply . . . . . 1336<sup>b</sup> (W. L. Walker)  
 Hapharaim (Haphrain). 1336<sup>b</sup>  
 Happen . . . . . 1336<sup>b</sup> (W. L. Walker)  
   of Chance . . . . . 593<sup>a</sup> (Trever)  
 Happiness . . . . . 1336<sup>b</sup>  
   of Blessedness . . . . . 487<sup>a</sup> (Gray)  
 Happizzez . . . . . 1336<sup>b</sup>  
 Hara . . . . . 1337<sup>a</sup> (Ewing)  
 Haradah . . . . . 1337<sup>a</sup>  
   of Wanderings of Israel 3064<sup>a</sup> (Conder)  
 Haran (person) . . . . . 1337<sup>a</sup>  
 Haran (place) . . . . . 1337<sup>a</sup> (Ewing)  
 Hararite . . . . . 1317<sup>b</sup>  
 Harbona, Harbonah . . . . . 1337<sup>b</sup> (Wolf)  
 Harbour . . . . . 1337<sup>b</sup>  
   of Haven . . . . . 1344<sup>b</sup> (Day)  
   of Ships and Boats . . . . . 2774<sup>a</sup> (Nicol)  
 Hard . . . . . 1337<sup>b</sup> (W. L. Walker)  
   of Harden . . . . . 1338<sup>a</sup> (W. L. Walker)  
 Hard Sayings . . . . . 1338<sup>b</sup>  
 Hard Sentences . . . . . 1338<sup>b</sup>  
 Harden . . . . . 1338<sup>a</sup> (W. L. Walker)  
   of Hard . . . . . 1337<sup>b</sup> (W. L. Walker)  
 Hardiness . . . . . 1337<sup>b</sup> (W. L. Walker)  
 Hardly  
   of Hard . . . . . 1337<sup>b</sup> (W. L. Walker)  
 Hardness  
   of Hard . . . . . 1337<sup>b</sup> (W. L. Walker)  
 Hare . . . . . 1338<sup>b</sup> (Day)  
 Hareph . . . . . 1339<sup>a</sup>  
 Hareth . . . . . 1339<sup>a</sup>  
   of Hereth . . . . . 1377<sup>a</sup> (Masterman)  
 Harhaiah . . . . . 1339<sup>a</sup>  
 Harhas . . . . . 1339<sup>a</sup>  
   of Hasrah . . . . . 1342<sup>b</sup>  
 Harhur . . . . . 1339<sup>a</sup>  
 Harim . . . . . 1339<sup>a</sup> (Stearns)  
   of Rehum . . . . . 2552<sup>b</sup> (Stearns)  
 Hariph (Jorah) . . . . . 1339<sup>b</sup>  
 Harlot . . . . . 1339<sup>b</sup> (Eager)  
   of Ashtoreth . . . . . 270<sup>b</sup> (Sayce)  
   of Idolatry . . . . . 1447<sup>b</sup> (Cobern)  
   of Images . . . . . 1452<sup>a</sup> (Cobern)  
 Harlotry . . . . . 746<sup>b</sup>  
   of Crimes . . . . . 745<sup>b</sup> (Hirsch)
- Har-magedon . . . . . 1340<sup>a</sup> (Ewing)  
 Harnepher . . . . . 1340<sup>b</sup>  
 Harness . . . . . 1340<sup>b</sup> (W. L. Walker)  
 Harod, Well of . . . . . 1340<sup>b</sup> (Ewing)  
   of Esdraelon, Plain of . . . . . 993<sup>a</sup> (Ewing)  
   of Jezreel . . . . . 1677<sup>a</sup> (Ewing)  
 Harodite . . . . . 1340<sup>b</sup>  
   of Harod, Well of . . . . . 1340<sup>b</sup> (Ewing)  
 Haroeh . . . . . 1341<sup>a</sup>  
   of Reaiah . . . . . 2534<sup>a</sup>  
 Harorite  
   of Harodite . . . . . 1340<sup>b</sup>  
 Harosheth, of the Gen-  
   tiles or of the Nations 1341<sup>a</sup> (Ewing)  
 Harp  
   of Music . . . . . 2099<sup>b</sup> (Millar)  
   of Musical Instru-  
   ments . . . . . 2101<sup>b</sup>  
 Harrow . . . . . 1341<sup>a</sup> (Patch)  
   of Agriculture . . . . . 75<sup>b</sup> (Patch)  
 Harrows . . . . . 1341<sup>a</sup>  
 Harsha . . . . . 1341<sup>a</sup>  
 Harsith . . . . . 1341<sup>a</sup>  
   of Deer . . . . . 817<sup>a</sup> (Day)  
   of Gate, East . . . . . 1176<sup>b</sup> (Caldecott)  
   of Jerusalem . . . . . 1595<sup>b</sup> (Masterman)  
   of Potsherd . . . . . 2423<sup>b</sup>  
 Hart  
   of Deer . . . . . 817<sup>a</sup> (Day)  
 Harum . . . . . 1341<sup>a</sup>  
 Harumaph . . . . . 1341<sup>b</sup>  
 Haruphite . . . . . 1341<sup>b</sup>  
   of Hareph . . . . . 1339<sup>a</sup>  
   of Hariph . . . . . 1339<sup>b</sup>  
 Haruz . . . . . 1341<sup>b</sup>  
 Harvest . . . . . 1341<sup>b</sup> (Patch)  
   of Agriculture . . . . . 75<sup>b</sup> (Patch)  
   Figurative . . . . . 1341<sup>b</sup> (Patch)  
   of Gleaning . . . . . 1234<sup>b</sup> (Patch)  
   of Mowing, Mown  
     Grass . . . . . 2093<sup>a</sup> (M. O. Evans)  
 Hasadiah . . . . . 1342<sup>a</sup>  
 Hasenuah  
   of Hassenuah . . . . . 1342<sup>b</sup>  
 Hashabiah . . . . . 1342<sup>a</sup> (Reeve)  
   of Sabias (Apoc) . . . . . 2636<sup>a</sup>  
 Hashabnah . . . . . 1342<sup>a</sup>  
 Hashabneiah . . . . . 1342<sup>a</sup>  
 Hashbadana (Hashbad-  
   dana) . . . . . 1342<sup>a</sup>  
 Hashem (Jashen) . . . . . 1342<sup>a</sup>  
 Hashmonah . . . . . 1342<sup>a</sup>  
   of Wanderings of Israel 3064<sup>a</sup> (Conder)  
 Hashub  
   of Hasshub . . . . . 1342<sup>b</sup>  
 Hashubah . . . . . 1342<sup>a</sup>  
 Hashum . . . . . 1342<sup>b</sup> (Downer)  
 Hasidaeans . . . . . 1342<sup>b</sup> (Hutchison)  
   of Maccabaeus, Macca-  
   bees . . . . . 1946<sup>b</sup> (Hutchison)  
   of Pharisees . . . . . 2361<sup>a</sup> (J. E. H. Thomson)

- Hasmoneans  
   cf Asmoneans . . . . . 283<sup>a</sup> (Dosker)  
   cf Heshmon . . . . . 1384<sup>b</sup>  
   cf Hyrcanus . . . . . 1445<sup>b</sup>  
   cf Sparta, Spartans . . . . . 2839<sup>b</sup> (Orr)  
   cf Temple . . . . . 2936<sup>b</sup> (Caldecott; Orr)  
 Hasrah . . . . . 1342<sup>b</sup>  
   cf Harhas . . . . . 1339<sup>a</sup>  
 Hassenaah (Senaah) . . . . . 1342<sup>b</sup>  
   cf Hassenuah . . . . . 1342<sup>b</sup>  
 Hassenuah . . . . . 1342<sup>b</sup>  
   cf Senuah . . . . . 2721<sup>a</sup>  
 Hasshub (Hashub) . . . . . 1342<sup>b</sup>  
 Hassophereth  
   cf Sophereth . . . . . 2836<sup>a</sup>  
 Haste (Hasty) . . . . . 1343<sup>a</sup> (W. L. Walker)  
 Hasupha (Hashupha) . . . . . 1343<sup>a</sup>  
   cf Gishpa . . . . . 1232<sup>a</sup>  
 Hat . . . . . 1343<sup>a</sup> (Eager)  
   cf Hood . . . . . 1419<sup>a</sup>  
 Hatach  
   cf Hathach . . . . . 1343<sup>b</sup>  
 Hatchet . . . . . 1343<sup>b</sup>  
   cf Ax . . . . . 341<sup>a</sup> (Patch)  
   cf Tools . . . . . 2998<sup>b</sup> (Easton)  
 Hate, Hatred . . . . . 1343<sup>b</sup> (Orr)  
   cf Enmity . . . . . 952<sup>b</sup> (W. L. Walker)  
 Hathach (Hatach) . . . . . 1343<sup>b</sup>  
 Hathath . . . . . 1343<sup>b</sup>  
 Hatipha . . . . . 1343<sup>b</sup>  
 Hatita . . . . . 1343<sup>b</sup>  
 Hatsi-hammenuchoth . . . . . 1343<sup>b</sup>  
   cf Menuhoth . . . . . 2033<sup>a</sup> (Wallace)  
 Hattil (Agia) . . . . . 1343<sup>b</sup>  
 Hattin, Horns of  
   cf Jesus Christ . . . . . 1642<sup>b</sup> (Orr)  
 Hattush . . . . . 1343<sup>b</sup> (Wolf)  
 Haunt . . . . . 1344<sup>a</sup>  
 Hauran . . . . . 1344<sup>a</sup> (Ewing)  
 Have . . . . . 1344<sup>b</sup> (W. L. Walker)  
 Haven . . . . . 1344<sup>b</sup> (Day)  
   cf Bithynia . . . . . 483<sup>a</sup> (White)  
   cf Harbour . . . . . 1337<sup>b</sup>  
   cf Shore . . . . . 2779<sup>b</sup> (Day)  
 Havens, Fair . . . . . 1087<sup>b</sup>  
 Havilah . . . . . 1345<sup>a</sup> (Fulton)  
 Havoc . . . . . 1345<sup>a</sup> (W. L. Walker)  
 Havoth-jair (Havoth-  
   jair) . . . . . 1345<sup>a</sup> (Ewing)  
   cf Jair . . . . . 1559<sup>a</sup> (Crichton)  
 Havvah . . . . . 1345<sup>a</sup>  
 Havvoth-jair (Havoth-  
   jair) . . . . . 1345<sup>a</sup> (Ewing)  
   cf Gilead . . . . . 1230<sup>a</sup> (Ewing)  
   cf Kamon . . . . . 1789<sup>b</sup> (Ewing)  
   cf Village . . . . . 3049<sup>b</sup> (Christie)  
   cf Town . . . . . 3001<sup>a</sup> (Christie)  
 Hawk . . . . . 1345<sup>a</sup> (Stratton-Porter)  
   cf Falcon . . . . . 1091<sup>b</sup> (Stratton-Porter)  
   cf Glede . . . . . 1234<sup>b</sup>  
   cf Kite . . . . . 1814<sup>a</sup> (Stratton-Porter)  
   cf Night-hawk . . . . . 2143<sup>b</sup> (Stratton-Porter)
- Hay  
   cf Grass . . . . . 1293<sup>a</sup> (Masterman)  
 Hazael . . . . . 1345<sup>b</sup> (Nicol); 437<sup>b</sup> (Nicol)  
 Hazaiiah . . . . . 1346<sup>b</sup>  
 Hazar . . . . . 1346<sup>b</sup> (Ewing)  
   Hazar-addar . . . . . 1346<sup>b</sup>  
   Hazar-enan . . . . . 1346<sup>b</sup>  
   Hazar-gaddah . . . . . 1347<sup>a</sup>  
   Hazar-hatticon . . . . . 1347<sup>a</sup>  
   Hazar-maveth . . . . . 1347<sup>a</sup>  
   Hazar-shual . . . . . 1347<sup>a</sup>  
   Hazar-susah . . . . . 1347<sup>a</sup>  
   Hazar-susim . . . . . 1347<sup>a</sup>  
 Hazar-addar  
   cf Hazar . . . . . 1346<sup>b</sup> (Ewing)  
   cf Village . . . . . 3049<sup>b</sup> (Christie)  
 Hazazon-tamar (Haze-  
   zon-tamar) . . . . . 1347<sup>a</sup> (Masterman)  
 Hazel  
   cf Almond . . . . . 100<sup>a</sup> (Masterman)  
 Hazeleponi (Hazzel-  
   poni) . . . . . 1348<sup>a</sup>  
 Hazer-hatticon . . . . . 1347<sup>a</sup>  
   cf Hazar . . . . . 1346<sup>b</sup> (Ewing)  
 Hazerim . . . . . 1347<sup>a</sup>  
 Hazeroth . . . . . 1347<sup>b</sup>  
   cf Wanderings of Is-  
   - rael . . . . . 3064<sup>a</sup> (Conder)  
 Hazezon-tamar  
   cf Hazazon-tamar . . . . . 1347<sup>a</sup> (Masterman)  
 Haziell . . . . . 1347<sup>b</sup>  
 Hazo . . . . . 1347<sup>b</sup>  
 Hazor . . . . . 1347<sup>b</sup> (Ewing)  
   cf Kerioth-hezron . . . . . 1793<sup>b</sup>  
   cf Merom . . . . . 2037<sup>a</sup> (Wright)  
   cf Village . . . . . 3049<sup>b</sup> (Christie)  
 Hazor-hadattah . . . . . 1347<sup>b</sup>  
 Hazzeleponi . . . . . 1348<sup>a</sup>  
 He . . . . . 1348<sup>a</sup>  
   cf Alphabet . . . . . 103<sup>b</sup> (Richardson)  
 Head . . . . . 1348<sup>a</sup> (Luering)  
   cf Hair . . . . . 1320<sup>a</sup> (Luering)  
   cf Heart . . . . . 1350<sup>b</sup> (Marais)  
 Headband  
   cf Dress . . . . . 875<sup>b</sup> (Eager)  
 Headdress  
   cf Bonnet . . . . . 495<sup>b</sup>  
   cf Dress . . . . . 875<sup>b</sup> (Eager)  
 Headstone  
   cf Corner-stone . . . . . 721<sup>b</sup> (Mack)  
 Headstrong  
   cf Heady . . . . . 1349<sup>a</sup>  
 Headtire  
   cf Bonnet . . . . . 495<sup>b</sup>  
   cf Dress . . . . . 875<sup>b</sup> (Eager)  
 Heady . . . . . 1349<sup>a</sup>  
 Heal . . . . . 1349<sup>a</sup> (Macalister)  
 Healed . . . . . 1349<sup>a</sup> (Macalister)  
 Healer . . . . . 1349<sup>a</sup> (Macalister)  
 Healing . . . . . 1349<sup>b</sup>  
 Healing, Gifts of . . . . . 1349<sup>b</sup> (Lambert)  
   cf Spiritual Gifts . . . . . 2843<sup>a</sup> (Lambert)



- Health . . . . . 1350<sup>a</sup> (Macalister)  
 Heap . . . . . 1350<sup>b</sup> (W. L. Walker)  
 Heart . . . . . 1350<sup>b</sup> (Marais)  
   cf Head . . . . . 1348<sup>a</sup> (Luering)  
   cf Psychology . . . . . 2496<sup>b</sup> (Marais)  
 Hearth . . . . . 1351<sup>b</sup> (Downer)  
   cf House . . . . . 1434<sup>b</sup> (A. C. Dickie)  
 Heartily . . . . . 1352<sup>a</sup>  
 Heat . . . . . 1352<sup>a</sup> (Joy)  
   cf Seasons . . . . . 2710<sup>b</sup> (Joy)  
 Heath  
   cf Tamarisk . . . . . 2908<sup>a</sup> (Masterman)  
 Heathen  
   cf Gentiles . . . . . 1215<sup>a</sup> (Porter)  
 Heave Offering  
   cf Sacrifice, OT . . . . . 2645<sup>b</sup> (Reeve)  
 Heaven  
   cf Astronomy . . . . . 300<sup>b</sup> (Maunder)  
   cf Sky . . . . . 2814<sup>b</sup> (Day)  
 Heaven, Host of  
   cf Astronomy . . . . . 300<sup>b</sup> (Maunder)  
 Heaven, Ordinances of  
   cf Astronomy . . . . . 300<sup>b</sup> (Maunder)  
 Heaven, Windows of  
   cf Astronomy . . . . . 300<sup>b</sup> (Maunder)  
 Heavenly . . . . . 1352<sup>b</sup> (Orr)  
   cf Heavens . . . . . 1352<sup>b</sup> (Orr)  
 Heavens . . . . . 1352<sup>b</sup> (Orr)  
   cf Heavenly . . . . . 1352<sup>b</sup> (Orr)  
 Heavens (physical) . . . . . 1352<sup>b</sup>  
   cf Astronomy . . . . . 300<sup>b</sup> (Maunder)  
   cf World, Cosmological 3106<sup>a</sup> (Orr)  
 Heavens, New (and  
   Earth, New) . . . . . 1353<sup>a</sup> (Vos)  
 Heavy, Heaviness, Heavily . . . . . 1354<sup>a</sup> (W. L. Walker)  
 Heber . . . . . 1354<sup>b</sup> (Pollard)  
 Heberites . . . . . 1354<sup>b</sup>  
   cf Tell el-Amarna Tablets . . . . . 2927<sup>b</sup> (Kyle)  
 Hebrew Apocryphal Gospels . . . . . 196<sup>b</sup> (Hutchison)  
 Hebrew, Hebrewess . . . . . 1355<sup>a</sup> (Orr)  
 Hebrew Language . . . . . 1355<sup>a</sup>  
   cf Aramaic Language 222<sup>a</sup> (J. E. H. Thomson)  
   cf Languages of OT . . . . . 1833<sup>a</sup> (Weir)  
   cf Semites, Semitic Religion . . . . . 2718<sup>b</sup> (Mack)  
 Hebrews, Epistle to the . . . . . 1355<sup>a</sup> (Rees); 467<sup>a</sup> (Orr)  
   Author . . . . . 1356<sup>b</sup>  
   Contents and teaching 1361<sup>a</sup>  
   Date . . . . . 1316<sup>a</sup>  
   Destination . . . . . 1358<sup>b</sup>  
   Doctrine of Logos . . . . . 1914<sup>b</sup> (Alexander)  
   Law in . . . . . 1851<sup>a</sup> (M'Caig)  
   Literary form . . . . . 1355<sup>b</sup>  
   Literary style . . . . . 1830<sup>b</sup> (A. T. Robertson)  
   cf Mediation . . . . . 2024<sup>b</sup> (Edwards)  
   Teaching regarding person of Christ . . . . . 2341<sup>a</sup> (Warfield)  
   Teaching on salvation 2670<sup>b</sup> (Easton)  
 Hebrews, Gospel according to the . . . . . 1362<sup>b</sup>  
   cf Apocryphal Gospels 195<sup>a</sup> (Hutchison)  
   Character and contents . . . . . 1363<sup>b</sup>  
   Circulation and language . . . . . 1364<sup>a</sup>  
   References in early church history . . . . . 1362<sup>b</sup>  
   Relation to St. Matthew . . . . . 1364<sup>a</sup>  
   Time of composition . . . . . 1364<sup>b</sup>  
   Uncanonical sayings and incidents . . . . . 1364<sup>b</sup>  
 Hebrews, Religion of the  
   cf Israel, Religion of . . . . . 1530<sup>b</sup> (Orelli)  
 Hebron (person) . . . . . 1366<sup>b</sup>  
 Hebron (place) . . . . . 1365<sup>a</sup> (Masterman)  
   cf Korah . . . . . 1816<sup>b</sup> (Beecher)  
   cf Machpelah . . . . . 1960<sup>a</sup> (Masterman)  
   cf Mamre . . . . . 1973<sup>a</sup> (Masterman)  
   cf Refuge, Cities of . . . . . 2545<sup>b</sup> (Ewing)  
 Hebronites . . . . . 1366<sup>b</sup>  
 Hedge . . . . . 1366<sup>b</sup> (Masterman)  
   cf Fence . . . . . 1106<sup>b</sup> (W. L. Walker)  
   cf Gederah . . . . . 1181<sup>b</sup>  
 Hedgehog . . . . . 1367<sup>a</sup>  
   cf Bittern . . . . . 484<sup>a</sup> (Stratton-Porter)  
   cf Owl . . . . . 2205<sup>b</sup> (Stratton-Porter)  
   cf Porcupine . . . . . 2421<sup>b</sup> (Day)  
   cf Serpent . . . . . 2736<sup>a</sup> (Day)  
 Heed . . . . . 1367<sup>a</sup> (Orr)  
 Heel . . . . . 1367<sup>a</sup> (M. O. Evans)  
 Heel (figurative) . . . . . 1367<sup>a</sup> (M. O. Evans)  
 Hegai, Hege . . . . . 1367<sup>a</sup>  
 Hegemonides . . . . . 1367<sup>a</sup>  
 Hegesippus . . . . . 1000<sup>a</sup> (J. E. H. Thomson)  
 Heifer . . . . . 1367<sup>b</sup> (Easton)  
   cf Cattle . . . . . 583<sup>b</sup> (Day)  
   cf Eglath-shelishiyah . . . . . 905<sup>b</sup> (Ewing)  
 Heifer, Red . . . . . 1367<sup>b</sup> (Easton)  
   cf Adultery . . . . . 63<sup>a</sup> (Margolis)  
   cf Cedar . . . . . 509<sup>b</sup> (Masterman)  
   cf Hyssop . . . . . 1445<sup>b</sup> (Masterman)  
   cf Sacrifice, OT . . . . . 2645<sup>a</sup> (Reeve)  
   cf Separation . . . . . 2721<sup>b</sup>  
   cf Talmud . . . . . 2906<sup>a</sup> (Strack)  
 Height, Heights . . . . . 1368<sup>a</sup> (Orr)  
 Heir . . . . . 1369<sup>a</sup> (Easton)  
   cf Inheritance . . . . . 1468<sup>b</sup> (Hirsch)  
   cf Marriage . . . . . 1996<sup>b</sup> (Eager)  
 Helah . . . . . 1369<sup>b</sup>  
 Helam . . . . . 1370<sup>a</sup>  
 Helbah . . . . . 1370<sup>a</sup>  
 Helbon . . . . . 1370<sup>a</sup> (Christie)  
 Helchiah . . . . . 1370<sup>a</sup>  
   cf Helkias . . . . . 1371<sup>a</sup>  
 Heldai . . . . . 1370<sup>a</sup>  
 Heleb, Heled  
   cf Heldai . . . . . 1370<sup>a</sup>  
 Helek . . . . . 1370<sup>a</sup>  
 Helcm . . . . . 1370<sup>a</sup>

- Helena of Adiabene  
   of Jerusalem . . . . . 1612<sup>a</sup> (Masterman)  
 Heleph . . . . . 1370<sup>a</sup>  
 Helez . . . . . 1370<sup>b</sup>  
 Heli . . . . . 1370<sup>b</sup>  
 Heliodorus . . . . . 1370<sup>b</sup> (Hutchison)  
   of Maccabees, Books  
     of . . . . . 1955<sup>b</sup> (T. W. Davies)  
     of Seleucus . . . . . 2715<sup>b</sup> (Hutchison)  
 Heliopolis  
   of On . . . . . 2193<sup>a</sup> (Kyle)  
 Helkai . . . . . 1370<sup>b</sup>  
 Helkath . . . . . 1370<sup>b</sup>  
 Helkath-hazzurim . . . . . 1370<sup>b</sup> (Ewing)  
   of Gibeon . . . . . 1226<sup>a</sup> (Ewing)  
 Helkias . . . . . 1371<sup>a</sup>  
   of Hilkiah . . . . . 1392<sup>a</sup> (Wallace)  
 Hell . . . . . 1371<sup>a</sup> (Orr)  
   of Eschatology of OT . . . . . 972<sup>a</sup> (Orr)  
   of Gehenna . . . . . 1183<sup>a</sup> (Vos)  
   of Hades . . . . . 1314<sup>b</sup> (Vos)  
   of Immortal . . . . . 1461<sup>a</sup> (Orr)  
   of Parousia . . . . . 2249<sup>a</sup> (Easton)  
   of Pit . . . . . 2401<sup>b</sup> (T. Lewis)  
   of Punishment, Ever-  
     lasting . . . . . 2501<sup>b</sup> (Orr)  
   of Sheol . . . . . 2761<sup>a</sup> (Orr)  
 Hellenism, Hellenist . . . . . 1371<sup>a</sup> (Heidel)  
   of Dionysus . . . . . 850<sup>a</sup> (Harry)  
   Expansion of Greek  
     peoples . . . . . 1371<sup>b</sup>  
   of Grecians . . . . . 1295<sup>a</sup> (Heidel)  
   of Greece, Religion of  
     Ancient . . . . . 1297<sup>a</sup> (Fairbanks)  
   Hellenic art and let-  
     ters . . . . . 1372<sup>b</sup>  
   Hellenic life . . . . . 1372<sup>a</sup>  
   Hellenic state . . . . . 1372<sup>a</sup>  
   of Paul . . . . . 2274<sup>a</sup> (A. T. Robertson)  
   Philosophy . . . . . 1372<sup>b</sup>  
   Religion . . . . . 1373<sup>a</sup>  
 Helm  
   of Ships and Boats . . . . . 2774<sup>a</sup> (Nicol)  
 Helmet  
   of Armor, Arms . . . . . 251<sup>a</sup> (Nicol)  
 Helon . . . . . 1374<sup>a</sup>  
 Help . . . . . 1374<sup>a</sup> (Orr)  
 Helpmeet  
   of Help . . . . . 1374<sup>a</sup> (Orr)  
 Helps . . . . . 1374<sup>a</sup> (Dosker)  
   of Ships and Boats . . . . . 2774<sup>a</sup> (Nicol)  
   of Spiritual Gifts . . . . . 2844<sup>b</sup> (Lambert)  
 Helve . . . . . 1374<sup>a</sup>  
 Hem . . . . . 1374<sup>a</sup> (Eager)  
   of Border . . . . . 503<sup>b</sup> (Hirsch)  
   of Dress . . . . . 875<sup>b</sup> (Eager)  
 Hemam  
   of Heman . . . . . 1374<sup>b</sup> (Pollard)  
   of Homam . . . . . 1417<sup>b</sup>  
 Heman . . . . . 1374<sup>b</sup> (Pollard)  
 Hemath  
   of Hammath . . . . . 1325<sup>a</sup> (Ewing)  
 Hemdan . . . . . 1374<sup>b</sup>  
 Hemlock  
   of Gall . . . . . 1166<sup>b</sup> (Masterman)  
 Hen . . . . . 1374<sup>b</sup>  
 Hen (person) . . . . . 1374<sup>b</sup>  
   of Josiah . . . . . 1751<sup>b</sup> (Genung)  
 Hena . . . . . 1374<sup>b</sup> (Ewing)  
   of Ivvah . . . . . 1544<sup>b</sup> (Pinches)  
 Henadad . . . . . 1374<sup>b</sup>  
   of Iliadun . . . . . 1449<sup>a</sup>  
 Henna . . . . . 1374<sup>b</sup>  
 Henech (Enoch) . . . . . 1374<sup>b</sup>  
   of Hanoch . . . . . 1336<sup>a</sup>  
 Hopher, Hopherites . . . . . 1375<sup>a</sup>  
 Hopher (place) . . . . . 1375<sup>a</sup>  
 Hephzibah . . . . . 1375<sup>a</sup>  
 Heraclitus  
   of Logos . . . . . 1912<sup>a</sup> (Alexander)  
 Herakles  
   of Hercules . . . . . 1375<sup>a</sup> (Hutchison)  
 Herald . . . . . 1375<sup>a</sup>  
   of Games . . . . . 1168<sup>b</sup> (Smith)  
 Herb . . . . . 1375<sup>a</sup> (Masterman)  
   of Bitter Herbs . . . . . 484<sup>a</sup> (Masterman)  
   of Grass . . . . . 1293<sup>a</sup> (Masterman)  
 Hercules (Herakles) . . . . . 1375<sup>a</sup> (Hutchison)  
 Herd  
   of Cattle . . . . . 583<sup>b</sup> (Day)  
 Herdsman . . . . . 1375<sup>b</sup> (Patch)  
   of Sheep . . . . . 2756<sup>b</sup> (Day)  
 Hereafter . . . . . 1375<sup>b</sup> (W. L. Walker)  
 Hereby . . . . . 1375<sup>b</sup> (W. L. Walker)  
 Heredity . . . . . 1376<sup>a</sup> (Easton)  
   of Blessing . . . . . 487<sup>b</sup> (Gray)  
   of Curse . . . . . 767<sup>a</sup> (T. Lewis)  
   of Death . . . . . 811<sup>a</sup> (Macalister)  
   of Family . . . . . 1094<sup>b</sup> (Cavono)  
   of Salvation . . . . . 2665<sup>a</sup> (Easton)  
   of Sin . . . . . 2798<sup>b</sup> (McConnell)  
   of Son . . . . . 2826<sup>a</sup> (Betteridge)  
   of Tradition . . . . . 3004<sup>a</sup> (Williams)  
 Herein . . . . . 1375<sup>a</sup> (W. L. Walker)  
 Hereof . . . . . 1376<sup>a</sup>  
 Heres . . . . . 1376<sup>b</sup> (Masterman)  
   of Ir-ha-heres . . . . . 1491<sup>a</sup> (Kyle)  
   of Ir-shemesh . . . . . 1493<sup>a</sup>  
 Hresh . . . . . 1376<sup>b</sup>  
 Heresy . . . . . 1377<sup>a</sup> (Jacobs)  
   of Sect . . . . . 2711<sup>b</sup> (W. L. Walker)  
 Hereth, The Forest of . . . . . 1377<sup>a</sup> (Masterman)  
   of Adullam . . . . . 62<sup>b</sup> (Beecher)  
 Heretic, Heretical . . . . . 1377<sup>a</sup>  
 Heretical Apocryphal  
   Gospels . . . . . 197<sup>a</sup> (Hutchison)  
 Heretofore . . . . . 1375<sup>b</sup> (W. L. Walker)  
 Hereunto . . . . . 1375<sup>a</sup> (W. L. Walker)  
 Herewith . . . . . 1376<sup>a</sup> (W. L. Walker)  
 Heritage . . . . . 1377<sup>b</sup>  
 Hermas . . . . . 1377<sup>b</sup> (S. F. Hunter)  
 Hermenties  
   of Interpretation . . . . . 1489<sup>a</sup> (Schodde)

- Hermes . . . . . 1377<sup>b</sup>  
 cf Mercury, Mercurius 2035<sup>a</sup> (M. O. Evans)
- Hermogenes . . . . . 1377<sup>b</sup> (Rutherford)  
 cf Phygelus . . . . . 2392<sup>b</sup> (Rutherford)
- Hermon, Little . . . . . 1378<sup>b</sup>
- Hermon, Mt. . . . . 1378<sup>a</sup> (Ewing)  
 cf Senir . . . . . 2720<sup>a</sup> (Ewing)  
 cf Sion . . . . . 2806<sup>a</sup>  
 cf Sirion . . . . . 2812<sup>b</sup>  
 cf Transfiguration, Mt.  
 of . . . . . 3006<sup>a</sup> (Ewing)
- Hermonites . . . . . 1378<sup>b</sup>
- Herod . . . . . 1378<sup>b</sup> (Dosker)  
 Herod Archelaus . . . . . 1382<sup>a</sup>  
 Herod Philip . . . . . 1382<sup>a</sup>  
 cf Temple . . . . . 2937<sup>a</sup> (Caldecott; Orr)
- Herod Agrippa I. . . . . 1382<sup>b</sup>  
 cf Paul . . . . . 2271<sup>b</sup> (A. T. Robertson)
- Herod Agrippa II. . . . . 1383<sup>a</sup>  
 cf Punishments . . . . . 2504<sup>b</sup> (Hirsch)
- Herod Antipas . . . . . 1381<sup>b</sup>  
 cf Jesus before . . . . . 1662<sup>a</sup> (Orr)  
 cf Jesus Christ's Arrest 1673<sup>a</sup> (Maclaren)  
 cf Manaen . . . . . 1976<sup>b</sup> (Orr)
- Herod the Great . . . . . 1379<sup>a</sup>  
 cf Jerusalem . . . . . 1611<sup>b</sup> (Masterman)  
 cf Jesus Christ . . . . . 1633<sup>b</sup>; 1727<sup>b</sup> (Orr)  
 cf Machaerus . . . . . 1959<sup>a</sup> (Ewing)
- Herodian Architecture . . . . . 238<sup>a</sup> (A. C. Dickie)
- Herodians . . . . . 1383<sup>b</sup> (Orr)
- Herodias . . . . . 1383<sup>b</sup> (Kerr)
- Herodion . . . . . 1384<sup>a</sup>  
 cf Junias . . . . . 1781<sup>a</sup> (S. F. Hunter)
- Heron . . . . . 1384<sup>a</sup> (Stratton-Porter)
- Hesed, Son of  
 cf Ben-hesed . . . . . 438<sup>a</sup>
- Heshbon . . . . . 1384<sup>a</sup> (Ewing)
- Heshmon . . . . . 1384<sup>b</sup>  
 cf Asmoneans . . . . . 283<sup>a</sup> (Dosker)
- Heth (letter) . . . . . 1384<sup>b</sup>  
 cf Alphabet . . . . . 103<sup>b</sup> (Richardson)
- Heth (person) . . . . . 1384<sup>a</sup>  
 cf Hittites . . . . . 1395<sup>b</sup> (Conder)
- Hethlon . . . . . 1384<sup>b</sup> (Christie)
- Hewer . . . . . 1384<sup>b</sup> (Patch)  
 cf Drawer of Water . . . . . 873<sup>b</sup> (Patch)
- Hexapla  
 cf Septuagint . . . . . 2726<sup>a</sup> (Thackeray)
- Hexateuch . . . . . 1385<sup>a</sup> (Wiener)  
 cf Joshua, Book of . . . . . 1749<sup>a</sup> (Geden)  
 cf Pentateuch . . . . . 2298<sup>a</sup> (Wiener)  
 cf Septuagint . . . . . 2729<sup>b</sup> (Thackeray)
- Hezeki  
 cf Hizki . . . . . 1402<sup>a</sup>
- Hezekiah (general) . . . . . 1385<sup>a</sup>
- Hezekiah (king) . . . . . 1385<sup>a</sup> (Genung)  
 cf Dial of Ahaz . . . . . 841<sup>a</sup> (Maunder)  
 Isaiah and . . . . . 1386<sup>a</sup>  
 cf Jerusalem . . . . . 1616<sup>b</sup> (Masterman)  
 cf Josiah . . . . . 1752<sup>b</sup>; 1753<sup>a</sup> (Genung)  
 Literary remains . . . . . 1388<sup>a</sup>  
 cf Israel, History of . . . . . 1523<sup>b</sup> (Orelli)
- Hezekiah—*continued*  
 cf Manasseh . . . . . 1977<sup>a</sup> (Wallace)  
 Reforms of . . . . . 1386<sup>a</sup>  
 cf Sennacherib . . . . . 2720<sup>b</sup> (Clay)  
 Siege of Jerusalem  
 under . . . . . 1386<sup>b</sup>  
 cf Siloam . . . . . 2792<sup>a</sup> (Masterman)
- Hezekiah's Sickness  
 cf Dial of Ahaz . . . . . 841<sup>a</sup> (Maunder)
- Hezekiah, The Men of . . . . . 1388<sup>a</sup>  
 cf Hezekiah . . . . . 1385<sup>a</sup> (Genung)  
 cf Proverbs, Book of . . . . . 2475<sup>b</sup> (Genung)
- Hezion . . . . . 1388<sup>b</sup>
- Hezir . . . . . 1388<sup>b</sup>
- Hezro, Hezrai . . . . . 1388<sup>b</sup>  
 cf Carmelite . . . . . 579<sup>b</sup>
- Hezron (person) . . . . . 1388<sup>b</sup>
- Hezron (place) . . . . . 1388<sup>b</sup>
- Hezronites . . . . . 1388<sup>b</sup>
- Hiddai (Hurai) . . . . . 1388<sup>b</sup>
- Hiddekel . . . . . 1388<sup>b</sup> (Wright)  
 cf Eden . . . . . 897<sup>b</sup> (Wright)
- Hidden . . . . . 1389<sup>a</sup> (W. L. Walker)
- Hiel . . . . . 1389<sup>a</sup> (Stearns)
- Hierapolis . . . . . 1389<sup>a</sup> (Banks)
- Hiereel (Jehiel) . . . . . 1389<sup>b</sup>
- Hieremoth (Jeremoth) . . . . . 1389<sup>b</sup>
- Hierielus  
 cf Jezrielus . . . . . 1677<sup>b</sup>
- Hiermas (Ramiah) . . . . . 1389<sup>b</sup>
- Higgaion . . . . . 1389<sup>b</sup>  
 cf Psalms, Book of . . . . . 2487<sup>a</sup> (Sampey)
- High Day . . . . . 1889<sup>b</sup>
- High, Most  
 cf God, Names of . . . . . 1264<sup>b</sup> (Mack)
- High Place . . . . . 1390<sup>a</sup> (Easton)  
 cf Altar . . . . . 108<sup>a</sup>; 109<sup>b</sup> (Wiener)  
 cf Bamoth . . . . . 381<sup>b</sup>  
 cf Criticism . . . . . 226<sup>a</sup> (Kyle)  
 cf Deuteronomy . . . . . 835<sup>b</sup> (Robinson)  
 cf Gezer . . . . . 1223<sup>b</sup> (Masterman)  
 cf Olives, Mount of . . . . . 2187<sup>a</sup> (Masterman)  
 cf Palestine, Recent  
 Exploration . . . . . 2234<sup>a</sup> (Cobern)  
 cf Ramah . . . . . 2527<sup>b</sup> (Ewing)  
 cf Religion of Israel . . . . . 1530<sup>b</sup> (Orelli)  
 cf Sanctuary . . . . . 2686<sup>b</sup> (Wiener)  
 cf Worship . . . . . 3111<sup>a</sup> (Crannell)
- High Priest . . . . . 2441<sup>b</sup> (Reeve)
- High Things . . . . . 1391<sup>b</sup> (W. L. Walker)
- Higher Criticism . . . . . 500<sup>b</sup> (Richardson)
- Highest . . . . . 1390<sup>a</sup> (W. L. Walker)  
 cf God, Names of . . . . . 1264<sup>b</sup> (Mack)
- Highminded . . . . . 1390<sup>a</sup> (W. L. Walker)
- Highway  
 cf Way . . . . . 3075<sup>b</sup> (Morro)
- Hilen (Holon) . . . . . 1392<sup>a</sup>
- Hilkiah . . . . . 1392<sup>a</sup> (Wallace)  
 cf Deuteronomy . . . . . 835<sup>b</sup> (Robinson)  
 cf Helkias . . . . . 1371<sup>a</sup>
- Hill of Ares . . . . . 239<sup>b</sup> (Harry)

- Hill, Hill Country . . . . . 1392<sup>a</sup> (Masterman)  
 of Country . . . . . 724<sup>a</sup> (Day)  
 of Ephraim, Mount . . . . . 963<sup>b</sup>  
 of Gibeah . . . . . 1225<sup>a</sup> (Ewing)  
 of Judah, Territory of . 1763<sup>b</sup> (Masterman)  
 of Natural Features . . . 2122<sup>a</sup> (Day)  
 of Ophel . . . . . 2196<sup>b</sup> (Masterman)  
 of Palestine . . . . . 2208<sup>b</sup> (Conder)
- Hill, Mount, Mountain . 1392<sup>b</sup> (Day)
- Hill of Evil Counsel  
 of Jerusalem . . . . . 1598<sup>b</sup> (Masterman)
- Hillel . . . . . 1393<sup>a</sup>
- Hin . . . . . 1393<sup>a</sup>  
 of Weights and Measures . . . . . 3079<sup>a</sup> (Porter)
- Hind  
 of Deer . . . . . 817<sup>a</sup> (Day)
- Hind of the Morning . . . 1393<sup>a</sup> (M. O. Evans)  
 of Morning . . . . . 2082<sup>b</sup> (Porter)  
 of Psalms . . . . . 2487<sup>a</sup> (Sampey)  
 of Song . . . . . 2830<sup>b</sup> (Millar)
- Hinge . . . . . 1393<sup>b</sup> (Caldecott)  
 of House . . . . . 1434<sup>b</sup> (A. C. Dickie)
- Hinnom, Valley of . . . . 1393<sup>b</sup> (Masterman)  
 of Akeldema . . . . . 89<sup>a</sup> (Masterman)  
 of Gehenna . . . . . 1183<sup>a</sup> (Vos)  
 of Gihon . . . . . 1228<sup>b</sup> (Masterman)  
 of Jackal's Well . . . . 1548<sup>b</sup> (Masterman)  
 of Jerusalem . . . . . 1599<sup>a</sup> (Masterman)  
 of Kidron, The Brook . 1798<sup>a</sup> (Masterman)  
 of Slaughter, Valley of 2815<sup>a</sup>
- Hip . . . . . 1394<sup>b</sup>  
 of Thigh . . . . . 2972<sup>b</sup> (Easton)
- Hippolytus . . . . . 1000<sup>a</sup> (J. E. H. Thomson)
- Hippopotamus  
 of Behemoth . . . . . 427<sup>a</sup> (Day)
- Hirah . . . . . 1394<sup>b</sup>
- Hiram . . . . . 1394<sup>b</sup> (Cotton)
- Hiram, Hiram, Hiram . . 1394<sup>b</sup>  
 of Hiram . . . . . 1442<sup>a</sup>
- Hircanus  
 of Hyrcanus . . . . . 1445<sup>b</sup>
- Hire . . . . . 1395<sup>a</sup> (McGlothlin)
- Hireling . . . . . 1395<sup>a</sup> (McGlothlin)
- His . . . . . 1395<sup>a</sup>
- Hiss . . . . . 1395<sup>b</sup> (W. L. Walker)
- Hitherto . . . . . 1395<sup>b</sup> (W. L. Walker)
- Hittites . . . . . 1395<sup>b</sup> (Conder)  
 of Archaeological theory  
 of . . . . . 231<sup>b</sup> (Kyle)  
 of Archaeology of Asia  
 Minor . . . . . 277<sup>a</sup> (White)  
 of In Asia Minor . . . . 274<sup>a</sup> (Calder)  
 of Heth . . . . . 1384<sup>b</sup>  
 History . . . . . 1396<sup>a</sup>  
 Inscriptions . . . . . 1401<sup>b</sup>  
 of Kadesh on Orontes . 1789<sup>a</sup> (Christie)  
 Language . . . . . 1399<sup>a</sup>  
 In Palestine . . . . . 1396<sup>a</sup>  
 of Palestine . . . . . 2217<sup>a</sup> (Conder)  
 of Palestine, Recent  
 Exploration . . . . . 2222<sup>b</sup> (Cobern)
- Hittites—*continued*  
 of Philistines . . . . . 2376<sup>b</sup> (Conder)  
 Religion . . . . . 1401<sup>a</sup>  
 of Sculpture of the . . . 279<sup>a</sup> (White)  
 of Syria . . . . . 2882<sup>a</sup> (Christie)  
 of Wanderings of Israel 3069<sup>a</sup> (Conder)  
 of Zoan . . . . . 3153<sup>a</sup> (Conder)
- Hivite . . . . . 1402<sup>a</sup> (Sayce)  
 of Horite . . . . . 1421<sup>b</sup> (Sayce)
- Hivites . . . . . 446<sup>b</sup> (Maunder)
- Hizki . . . . . 1402<sup>a</sup>
- Hizkiah . . . . . 1402<sup>a</sup>  
 of Hezekiah (general) . 1385<sup>a</sup>
- Hoar, Hoary  
 of Color . . . . . 674<sup>b</sup> (Patch)  
 of Hair . . . . . 1320<sup>a</sup> (Luering)
- Hoar-frost, Hoary  
 of Frost . . . . . 1147<sup>a</sup> (Joy)
- Hobab . . . . . 1402<sup>b</sup> (Cotton)  
 of Jethro . . . . . 1674<sup>b</sup> (Crichton)  
 of Reuel . . . . . 2573<sup>b</sup> (Wolf)
- Hobah . . . . . 1402<sup>b</sup>
- Hobaiah . . . . . 1402<sup>b</sup>  
 of Habaiah . . . . . 1311<sup>a</sup>  
 of Obdia . . . . . 2174<sup>b</sup>
- Hock . . . . . 1402<sup>b</sup>
- Hod . . . . . 1402<sup>b</sup>
- Hodaiah  
 of Hodaviah . . . . . 1403<sup>a</sup>
- Hodaviah (Hodevah) . . . 1403<sup>a</sup>
- Hodeiah (Hodevah) . . . 1403<sup>b</sup>
- Hodesh . . . . . 1403<sup>a</sup>
- Hodevah (Hodaviah, Hodeiah) . . . 1403<sup>a</sup>  
 of Sudias . . . . . 2869<sup>b</sup>
- Hodiah, Hodijah . . . . 1403<sup>a</sup> (McAllister)
- Hoglah . . . . . 1403<sup>a</sup>
- Hoham . . . . . 1365<sup>b</sup>; 1403<sup>a</sup>
- Hoise . . . . . 1403<sup>a</sup>
- Hold . . . . . 1403<sup>a</sup>  
 of Fortification . . . . 1136<sup>b</sup> (Nicol)
- Holding . . . . . 1403<sup>a</sup> (W. L. Walker)
- Holiness . . . . . 1403<sup>b</sup> (Lambert)  
 NT usage . . . . . 1404<sup>a</sup>  
 OT usage . . . . . 1403<sup>b</sup>  
 of Sanctification . . . . 2681<sup>b</sup> (Rall)
- Hollow . . . . . 1404<sup>b</sup> (W. L. Walker)
- Holm-tree . . . . . 1405<sup>a</sup> (Masterman)  
 of Susanna, History of 2872<sup>b</sup> (T. W. Davies)
- Holofernes . . . . . 1405<sup>a</sup> (Hutchison)
- Holon . . . . . 1405<sup>a</sup>
- Holy  
 of Separate . . . . . 2721<sup>b</sup>
- Holyday . . . . . 1405<sup>a</sup> (T. Lewis)
- Holy Ghost  
 of Holy Spirit . . . . . 1406<sup>a</sup> (Mullins)
- Holy Ghost (Spirit),  
 Sin against the  
 of Blasphemy . . . . . 485<sup>b</sup> (Rees)  
 of Holy Spirit . . . . . 1411<sup>b</sup> (Mullins)
- Holy of Holies . . . . . 1405<sup>a</sup> (Caldecott)  
 of Ark of Covenant . . . 242<sup>b</sup> (Lotz)

Holy of Holies—*continued*

- cf Day of Atonement. . . . . 324<sup>b</sup> (Möller)  
 cf Mercy-seat . . . . . 2036<sup>a</sup> (Caldecott)  
 cf Tabernacle . . . . . 2887<sup>b</sup> (Caldecott; Orr)  
 cf Temple . . . . . 2930<sup>a</sup> (Caldecott; Orr)
- Holy One**  
 cf God, Names of. . . . . 1264<sup>b</sup> (Mack)
- Holy Place** . . . . . 1405<sup>b</sup> (Caldecott)  
 cf Tabernacle . . . . . 2887<sup>b</sup> (Caldecott; Orr)  
 cf Temple . . . . . 2930<sup>a</sup> (Caldecott; Orr)
- Holy Sepulchre**  
 cf Jerusalem . . . . . 1613<sup>a</sup> (Masterman)
- Holy Spirit** . . . . . 1406<sup>a</sup> (Mullins)  
 cf Advocate . . . . . 65<sup>a</sup> (Mullins)  
 cf Baptism of the  
   Holy Spirit . . . . . 399<sup>b</sup> (Mullins)  
 cf Blasphemy . . . . . 485<sup>b</sup> (Rees)  
 cf Ghost . . . . . 1224<sup>a</sup> (W. L. Walker)  
 cf God . . . . . 1264<sup>a</sup> (Rees)  
 cf Grace . . . . . 1290<sup>a</sup> (Easton)  
 cf Johannine The-  
   ology . . . . . 1700<sup>a</sup> (Law)  
 In non-canonical lit-  
   erature . . . . . 1409<sup>b</sup>  
 cf Paraclete . . . . . 2245<sup>a</sup> (Mullins)  
 cf Pauline Theology . . . . . 2290<sup>a</sup> (Easton)  
 cf Personality of . . . . . 1701<sup>a</sup> (Law)  
 cf Salvation . . . . . 2669<sup>a</sup> (Easton)  
 cf Sanctification . . . . . 2681<sup>b</sup> (Rall)  
 cf Spirit . . . . . 2841<sup>b</sup> (Marais)
- Teaching in the NT** . . . . . 1410<sup>a</sup>  
 In the Kingdom of  
   God . . . . . 1412<sup>a</sup>  
 In the life of Christ . . . . . 1410<sup>a</sup>  
 In other NT writ-  
   ings . . . . . 1417<sup>b</sup>  
 In Paul's writings . . . . . 1415<sup>a</sup>
- Teaching in the OT** . . . . . 1406<sup>a</sup>  
 In external nature . . . . . 1407<sup>a</sup>  
 Imparting powers for  
   service . . . . . 1407<sup>b</sup>  
 In prophecy . . . . . 1408<sup>a</sup>  
 cf Tongues, Gift of . . . . . 2995<sup>b</sup> (Easton)
- Homam (Heman)** . . . . . 1417<sup>b</sup>
- Home** . . . . . 1417<sup>b</sup> (Downer)
- Home-born** . . . . . 1418<sup>a</sup>
- Homer** . . . . . 1418<sup>a</sup>  
 cf Weights and Meas-  
   ures . . . . . 3079<sup>a</sup> (Porter)
- Homicide** . . . . . 1418<sup>a</sup> (Levertoff); 746<sup>b</sup>  
   (Hirsch)  
 cf Refuge, Cities of . . . . . 2545<sup>b</sup> (Ewing)
- Honest, Honesty** . . . . . 1418<sup>b</sup> (Orr)
- Honey** . . . . . 1418<sup>b</sup> (Patch)  
 cf Food . . . . . 1121<sup>b</sup> (Eager)  
 cf Pannag . . . . . 2237<sup>b</sup> (Masterman)  
 cf Wine . . . . . 3086<sup>a</sup> (Easton)
- Honorable** . . . . . 1419<sup>a</sup> (W. L. Walker)
- Hood** . . . . . 1419<sup>a</sup>  
 cf Dress . . . . . 875<sup>b</sup> (Eager)  
 cf Hat . . . . . 1343<sup>a</sup> (Eager)
- Hoof**  
 cf Chew Cud . . . . . 605<sup>b</sup> (N. Isaacs)  
 cf Cloven . . . . . 671<sup>a</sup> (Jacobs)
- Hook** . . . . . 1419<sup>a</sup> (Easton)  
 cf Flesh-hook . . . . . 1119<sup>b</sup> (Doolan)  
 cf Jaw . . . . . 1572<sup>a</sup> (M. O. Evans)  
 cf Thorns, Thistles, etc 2974<sup>a</sup> (Masterman)
- Hoopoe** . . . . . 1419<sup>a</sup> (Stratton-Porter)  
 cf Lapwing . . . . . 1839<sup>b</sup>
- Hope** . . . . . 1419<sup>b</sup> (Easton)  
 cf Eschatology of the  
   NT . . . . . 979<sup>b</sup> (Vos)  
 cf Faith . . . . . 1087<sup>b</sup> (Dunelm)  
 cf Forgiveness . . . . . 1132<sup>b</sup> (Morro)  
 cf Israel, Religion of . . . . . 1530<sup>b</sup> (Orelli)  
 cf Kingdom of God . . . . . 1805<sup>a</sup> (Stalker)  
 cf Messiah . . . . . 2039<sup>a</sup> (Crichton)  
 In NT . . . . . 1420<sup>a</sup>  
 In OT . . . . . 1419<sup>b</sup>  
 cf Parousia . . . . . 2249<sup>a</sup> (Easton)  
 cf Salvation . . . . . 2665<sup>a</sup> (Easton)
- Hophni and Phinehas** . . . . . 1421<sup>a</sup> (Wallace)  
 cf Ichabod . . . . . 1446<sup>b</sup> (Wallace)  
 cf Phinehas . . . . . 2385<sup>b</sup> (Wallace)
- Hopra**  
 cf Pharaoh Hophra . . . . . 2359<sup>b</sup> (Nicol)
- Hor, Mount** . . . . . 1421<sup>a</sup> (Ewing)  
 cf Halak, Mount . . . . . 1322<sup>a</sup> (Ewing)
- Horam** . . . . . 1421<sup>b</sup>
- Horeb**  
 cf Massah and Meribah 2007<sup>a</sup> (Ewing)  
 cf Sinai . . . . . 2802<sup>b</sup> (Conder)
- Horem** . . . . . 1421<sup>b</sup>
- Horesh** . . . . . 1421<sup>b</sup>
- Hor-haggidgad** . . . . . 1421<sup>b</sup>  
 cf Wanderings of Israel 3064<sup>a</sup> (Conder)
- Hori** . . . . . 1421<sup>b</sup>
- Horite, Horim** . . . . . 1421<sup>b</sup> (Sayce)  
 cf Hivite . . . . . 1402<sup>a</sup> (Sayce)
- Hormah** . . . . . 1422<sup>a</sup> (Ewing)
- Horn** . . . . . 1422<sup>a</sup> (Easton)  
 cf Altar . . . . . 106<sup>b</sup> (Wiener)  
 cf Horns of the Altar . . . . . 1422<sup>b</sup> (Caldecott)  
 cf Ink-horn . . . . . 1469<sup>b</sup> (Richardson)  
 cf Lift . . . . . 1890<sup>b</sup> (Easton)  
 cf Music . . . . . 2094<sup>b</sup> (Millar)
- Hornet** . . . . . 1422<sup>b</sup> (Day)
- Horns of the Altar** . . . . . 1422<sup>b</sup> (Caldecott)  
 cf Altar . . . . . 106<sup>b</sup> (Wiener)  
 cf Horn . . . . . 1422<sup>a</sup> (Easton)
- Horns, Rams'**  
 cf Music . . . . . 2094<sup>b</sup> (Millar)
- Horns, Stream of**  
 cf Shihor . . . . . 2768<sup>a</sup> (Kyle)
- Horonaim** . . . . . 1423<sup>a</sup> (Ewing)
- Horonite** . . . . . 1423<sup>a</sup>  
 cf Beth-horon . . . . . 446<sup>a</sup> (Masterman)
- Horrible** . . . . . 1423<sup>a</sup> (W. L. Walker)
- Horror** . . . . . 1423<sup>a</sup>
- Horse** . . . . . 1423<sup>a</sup> (Day)  
 cf Camel . . . . . 547<sup>b</sup> (Day)  
 cf Swift Beasts . . . . . 2875<sup>b</sup>

- Horse, Black . . . . . 1423<sup>b</sup>  
 of Revelation of John . . . 2582<sup>b</sup> (Orr)
- Horse Gate  
 of Jerusalem . . . . . 1606<sup>b</sup> (Masterman)
- Horse, Red . . . . . 1423<sup>b</sup>  
 of Revelation of John . . . 2582<sup>b</sup> (Orr)
- Horse, White . . . . . 1424<sup>a</sup>  
 of Revelation of John . . . 2582<sup>b</sup> (Orr)
- Horseleach . . . . . 1424<sup>a</sup> (Day)  
 of Vampire . . . . . 3045<sup>b</sup>
- Horseman  
 of Army . . . . . 254<sup>b</sup> (Nicol)
- Horses of the Sun . . . . . 1424<sup>a</sup>  
 of Sun-worship . . . . . 2870<sup>b</sup> (Orr)
- Hosah . . . . . 1424<sup>a</sup>
- Hosanna . . . . . 1424<sup>a</sup> (W. L. Walker)
- Hosea . . . . . 1424<sup>b</sup> (J. Robertson)  
 The book . . . . . 1426<sup>a</sup>  
 Concern for Israel . . . 1431<sup>b</sup>  
 Contents and di-  
 visions . . . . . 1427<sup>a</sup>  
 Historical back-  
 ground . . . . . 1427<sup>a</sup>  
 References to earlier  
 history . . . . . 1429<sup>b</sup>  
 Style and scope . . . . . 1426<sup>b</sup>  
 of Gomer (his wife) . . . 1276<sup>b</sup> (Reeve)  
 of Israel, Religion of . . 1538<sup>b</sup> (Orelli)  
 of Lo-ammi . . . . . 1907<sup>a</sup> (Lees)  
 The prophet . . . . . 1424<sup>a</sup>  
 The prophet, date . . . . 1425<sup>a</sup>  
 The prophet, personal  
 history (marriage) . . . 1425<sup>a</sup>  
 of Sacrifice, OT . . . . . 2648<sup>a</sup> (Reeve)
- Hosen  
 of Breeches . . . . . 518<sup>a</sup> (Wolf)
- Hoshaiah . . . . . 1431<sup>a</sup>
- Hoshama . . . . . 1431<sup>a</sup>
- Hoshea . . . . . 1431<sup>a</sup> (Caldecott)
- Hoshea (Osea) . . . . . 2202<sup>a</sup>
- Hospitality . . . . . 1432<sup>a</sup> (Easton)  
 of Bread . . . . . 514<sup>b</sup> (Eager)  
 In the churches . . . . . 1433<sup>b</sup>  
 of Guest . . . . . 1308<sup>b</sup> (Clippinger)  
 of Jael . . . . . 1557<sup>b</sup> (Schenk)  
 In the OT . . . . . 1432<sup>b</sup>  
 of Relationships, Fam-  
 ily . . . . . 2556<sup>b</sup> (N. and E. D. Isaacs)  
 of Romans, Epistle to . . 2614<sup>a</sup> (Dunelm)  
 of Sacrifice, NT . . . . . 2651<sup>a</sup> (Williams)
- Host of Heaven . . . . . 1433<sup>b</sup> (Orr)  
 of Angel . . . . . 132<sup>b</sup> (J. M. Wilson)  
 of Astronomy . . . . . 300<sup>b</sup> (Maunder)  
 of Lord of Hosts . . . . . 1919<sup>a</sup>
- Hostage  
 of War . . . . . 3069<sup>b</sup> (Nicol)
- Hosts, Lord of . . . . . 1919<sup>a</sup>
- Hotham (Hothan) . . . . . 1434<sup>a</sup>
- Hothir . . . . . 1434<sup>a</sup>
- Hough  
 of Hoek . . . . . 1402<sup>b</sup>
- Hour . . . . . 1434<sup>a</sup> (Porter)  
 of Time . . . . . 2981<sup>b</sup> (Porter)
- Hours of Prayer . . . . . 1434<sup>a</sup> (Dosker)
- House . . . . . 1434<sup>b</sup> (A. C. Dickie)  
 of Corner-stone . . . . . 721<sup>b</sup> (Mack)  
 of Fold, Folding . . . . . 1121<sup>a</sup> (W. L. Walker)  
 of Furniture . . . . . 1150<sup>a</sup> (Reeve)  
 of Gezer . . . . . 1222<sup>a</sup> (Masterman)  
 of Habitation . . . . . 1313<sup>a</sup> (Orr)  
 of Hearth . . . . . 1351<sup>b</sup> (Downer)  
 of Hinge . . . . . 1393<sup>b</sup> (Caldecott)  
 of House of God . . . . . 1438<sup>a</sup> (Orr)  
 of Household . . . . . 1438<sup>a</sup> (Dosker)  
 of Key . . . . . 1793<sup>b</sup> (Pollard)  
 of Mason . . . . . 2007<sup>a</sup>  
 of Palace . . . . . 2208<sup>a</sup> (Orr)  
 of Parlor . . . . . 2248<sup>b</sup>  
 of Post . . . . . 2423<sup>a</sup> (M. O. Evans)  
 of Temple . . . . . 2930<sup>a</sup> (Caldecott; Orr)  
 of Tile, Tiling . . . . . 2981<sup>b</sup>  
 of Upper Chamber . . . . 3039<sup>a</sup> (Orr)
- House, Father's . . . . . 1101<sup>a</sup> (W. L. Walker)
- House, Garden . . . . . 1175<sup>a</sup>
- House of God . . . . . 1438<sup>a</sup> (Orr)  
 of Bethel . . . . . 443<sup>b</sup> (Ewing)  
 of House . . . . . 1434<sup>b</sup> (A. C. Dickie)
- Household . . . . . 1438<sup>a</sup> (Dosker)  
 of House . . . . . 1434<sup>b</sup> (A. C. Dickie)
- Household, Caesar's . . . . 537<sup>a</sup> (Rutherford)
- Householder . . . . . 1438<sup>b</sup>
- Housetop  
 of House . . . . . 1434<sup>b</sup> (A. C. Dickie)
- How, Howbeit, Howso-  
 ever . . . . . 1438<sup>b</sup> (W. L. Walker)
- Hozai . . . . . 1439<sup>a</sup> (McAllister)  
 of Apocrypha . . . . . 178<sup>b</sup> (T. W. Davies)
- Huckster . . . . . 1439<sup>a</sup>
- Hukkok . . . . . 1439<sup>a</sup>
- Hukok  
 of Helkath . . . . . 1370<sup>b</sup>
- Hul . . . . . 1439<sup>a</sup>
- Huldah . . . . . 1439<sup>a</sup> (Reeve)
- Huleh, Lake  
 of Jordan . . . . . 1733<sup>a</sup> (Wright)
- Human Sacrifice  
 of Molech . . . . . 2075<sup>a</sup> (Nicol)  
 of Sacrifice, Human . . . 2658<sup>a</sup> (McGlothlin)  
 of Sacrifice, OT . . . . . 2647<sup>b</sup> (Reeve)
- Humiliation of Christ  
 of Kenosis . . . . . 1792<sup>a</sup> (Easton)  
 of Person of Christ . . . 2338<sup>a</sup> (Warfield)  
 of Prize . . . . . 2457<sup>a</sup> (Edwards)
- Humility . . . . . 1439<sup>b</sup> (W. L. Walker)
- Humps (Bunches) . . . . . 1440<sup>a</sup>
- Humtah . . . . . 1440<sup>a</sup>
- Hundred  
 of Number . . . . . 2157<sup>a</sup> (Smith)
- Hunger . . . . . 1440<sup>a</sup> (Macalister)
- Hunting . . . . . 1440<sup>a</sup> (Smith)  
 of Fowler . . . . . 1143<sup>a</sup> (Stratton-Porter)  
 Methods of . . . . . 1440<sup>b</sup>  
 In OT . . . . . 1440<sup>b</sup>
- Hupham . . . . . 1441<sup>b</sup>
- Huppah . . . . . 1441<sup>b</sup>

- Huppim  
 cf Hupham . . . . . 1441<sup>b</sup>  
 Hur . . . . . 1441<sup>b</sup> (Downer)  
 Hurai . . . . . 1442<sup>a</sup>  
 Hurai (Hiddai) . . . . . 1388<sup>b</sup>  
 Hiram (Hiram) . . . . . 1442<sup>a</sup>  
 Huri . . . . . 1442<sup>a</sup>  
 Hurt . . . . . 1442<sup>a</sup> (Orr)  
 Husband . . . . . 1442<sup>a</sup> (Eager)  
 Husbandman, Husband-  
 ry . . . . . 1442<sup>b</sup> (Patch)  
 of Agriculture . . . . . 75<sup>b</sup> (Patch)  
 Husband's Brother . . . . . 1442<sup>b</sup> (Crannell)  
 of Family . . . . . 1094<sup>b</sup> (Caverno)  
 Hushab . . . . . 1443<sup>a</sup>  
 Hushai . . . . . 1443<sup>a</sup> (Reeve)  
 Husham . . . . . 1443<sup>a</sup>  
 Hushathite . . . . . 1443<sup>a</sup>  
 of Mebunnai . . . . . 2016<sup>b</sup> (Wallace)  
 of Sibbeccai . . . . . 2783<sup>a</sup>  
 Hushim . . . . . 1443<sup>a</sup>  
 Hushshathite  
 of Hushathite . . . . . 1443<sup>a</sup>  
 Husks . . . . . 1443<sup>a</sup> (Masterman)  
 Huz  
 of Uz . . . . . 3042<sup>a</sup> (Reeve)  
 Huzzab . . . . . 1443<sup>b</sup> (Crannell)  
 Hyacinth (Jacinth) . . . . . 1443<sup>b</sup>  
 of Stones, Precious . . . . . 2860<sup>a</sup> (Fletcher)  
 Hyades  
 of Astrology . . . . . 295<sup>b</sup> (Maunder)  
 Hydaspes . . . . . 1443<sup>b</sup>  
 Hydromancy . . . . . 331<sup>b</sup> (T. W. Davies)  
 Hyena . . . . . 1443<sup>b</sup> (Day)  
 Hyksos  
 of Joseph . . . . . 1739<sup>a</sup> (Kyle)  
 Hymenaeus . . . . . 1444<sup>a</sup> (Rutherford)  
 of Alexander . . . . . 90<sup>a</sup> (Rutherford)  
 of Philetus . . . . . 2367<sup>b</sup> (Rutherford)  
 Hymn . . . . . 1445<sup>a</sup> (Millar)  
 of Music . . . . . 2094<sup>b</sup> (Millar)  
 of Song . . . . . 2830<sup>b</sup> (Millar)  
 Hypocrisy, Hypocrite . . . . . 1445<sup>a</sup> (W. L. Walker)  
 Hyrcanus . . . . . 1445<sup>b</sup>  
 of Aristobulus . . . . . 241<sup>b</sup> (M. O. Evans)  
 of Asmoneans . . . . . 283<sup>a</sup> (Dosker)  
 of Maccabaeus . . . . . 1946<sup>a</sup> (Hutchison)  
 of Tobias . . . . . 2990<sup>b</sup>  
 Hyssop . . . . . 1445<sup>b</sup>  
 of Heifer, Red . . . . . 1367<sup>b</sup> (Easton)
- I, I Am, I Am That I Am  
 of God, Names of . . . . . 1267<sup>b</sup> (Mack)
- I Will Be  
 of God, Names of . . . . . 1267<sup>b</sup> (Mack)
- Iacimus  
 of Alcimus . . . . . 89<sup>b</sup> (Mack)  
 Iacubus (Akkub) . . . . . 1446<sup>a</sup>  
 Iadinus (Jamin) . . . . . 1446<sup>a</sup>  
 Ibelin  
 of Jabneel . . . . . 1547<sup>a</sup> (Porter)
- Ibhar (Juchabar) . . . . . 1446<sup>a</sup>  
 Ibis . . . . . 1446<sup>a</sup>  
 of Owl . . . . . 2205<sup>b</sup> (Stratton-Porter)  
 Ibleam (Bileam) . . . . . 1446<sup>a</sup> (Ewing)  
 of Gath-rimmon . . . . . 1178<sup>a</sup> (Ewing)  
 Ibneiah . . . . . 1446<sup>a</sup>  
 Ibnijah . . . . . 1446<sup>a</sup>  
 Ibri . . . . . 1446<sup>a</sup>  
 Ibsam . . . . . 1446<sup>b</sup>  
 Ibzam . . . . . 1446<sup>b</sup> (E. D. Isaacs)  
 Ice . . . . . 1446<sup>b</sup> (Joy)  
 Figurative . . . . . 1446<sup>b</sup> (Joy)  
 Ichabod . . . . . 1446<sup>b</sup> (Wallace)  
 of Hophni and Phine-  
 has . . . . . 1421<sup>a</sup> (Wallace)  
 Iconium . . . . . 1446<sup>b</sup> (Calder)  
 of Lycaonia . . . . . 1942<sup>b</sup> (Calder)  
 of Lystra . . . . . 1944<sup>a</sup> (Calder)  
 Idalah . . . . . 1447<sup>a</sup>  
 Idbash . . . . . 1447<sup>b</sup>  
 Iddo (Addo, Oded) . . . . . 1447<sup>b</sup> (Crannell)  
 of Jadau . . . . . 1557<sup>a</sup>  
 Idle, Idleness . . . . . 1447<sup>b</sup> (T. Lewis)  
 Idol  
 of Image . . . . . 1450<sup>a</sup> (Edwards)  
 Idolatry . . . . . 1447<sup>b</sup> (Cobern)  
 of Calf, Golden . . . . . 298<sup>a</sup>; 542<sup>b</sup> (Cobern)  
 of Divination . . . . . 860<sup>a</sup> (T. W. Davies)  
 of Fire . . . . . 1112<sup>a</sup> (W. L. Walker)  
 of Gods . . . . . 1270<sup>b</sup> (Reeve)  
 of Harlot . . . . . 1339<sup>b</sup> (Eager)  
 of High Place . . . . . 1390<sup>a</sup> (Easton)  
 of Image . . . . . 1450<sup>a</sup> (Edwards)  
 of Images . . . . . 1452<sup>a</sup> (Cobern)  
 of Jeremiah . . . . . 1589<sup>b</sup> (Orelli)
- Idols  
 of Gods . . . . . 1270<sup>b</sup> (Reeve)
- Iduel (Ariel) . . . . . 1448<sup>b</sup>  
 Idumaea, Idumaeans . . . . . 1448<sup>b</sup>  
 of Edom . . . . . 899<sup>a</sup> (Ewing)  
 Ieddias (Eddias) . . . . . 1448<sup>b</sup>  
 Ieiel  
 of Jehiah . . . . . 1574<sup>a</sup>  
 Iezer, Iezerites . . . . . 1448<sup>b</sup>  
 of Abiezer . . . . . 9<sup>a</sup> (Beecher)  
 Igal . . . . . 1448<sup>b</sup>  
 Igdaliah . . . . . 1448<sup>b</sup>  
 Igeal . . . . . 1448<sup>b</sup>  
 Ignatius, Ep. of  
 of Literature, Sub-apost. 1899<sup>b</sup> (Cowan)  
 Ignorance . . . . . 1448<sup>b</sup> (W. L. Walker)  
 Iim (Iyim) . . . . . 1545<sup>a</sup>  
 Ije-abarim  
 of Iye-abarim . . . . . 1545<sup>a</sup>  
 Ijon . . . . . 1449<sup>a</sup> (Ewing)  
 Ikkesb . . . . . 1449<sup>a</sup>  
 Ilai (Zalmon) . . . . . 1449<sup>a</sup>  
 of Zalmon . . . . . 3131<sup>b</sup> (Ewing)  
 Iliadun . . . . . 1449<sup>a</sup>  
 of Henadad . . . . . 1374<sup>b</sup>  
 Ill, Ill-favored  
 of Evil-favoredness . . . . . 1043<sup>a</sup> (Luering)

- Illumination . . . . . 1449<sup>a</sup> (Easton)  
 Illustrious, The . . . . . 1449<sup>b</sup>  
   cf Apame . . . . . 160<sup>b</sup>  
   cf Bartacus . . . . . 406<sup>b</sup>  
 Illyricum . . . . . 1449<sup>b</sup> (Tod)  
   cf Dalmatia . . . . . 777<sup>b</sup> (Tod)  
 Image . . . . . 1450<sup>a</sup> (Edwards)  
   Christ, image of . . . . . 1451<sup>a</sup>  
   cf Divination . . . . . 860<sup>a</sup> (T. W. Davies)  
   cf Idolatry . . . . . 1447<sup>b</sup> (Cobern)  
   cf Images . . . . . 1452<sup>a</sup> (Cobern)  
   Man in Divine image . 1450<sup>a</sup>  
   cf Pillar . . . . . 2398<sup>b</sup> (Orr)  
 Image of God . . . . . 1264<sup>b</sup> (Orr)  
 Imagery . . . . . 1452<sup>a</sup> (Edwards)  
   cf Images . . . . . 1452<sup>a</sup> (Cobern)  
 Images . . . . . 1452<sup>a</sup> (Cobern)  
   cf Astarte (Ashtaroth) . 270<sup>a</sup> (Ewing)  
   Bible references . . . . . 1454<sup>a</sup>  
   cf Calf, Golden . . . . . 298<sup>a</sup>; 542<sup>b</sup> (Cobern)  
   cf Chambers of Image-  
   ry . . . . . 592<sup>a</sup>  
   cf Chariots of the Sun . 596<sup>b</sup> (Margolis)  
   cf Ephod . . . . . 8<sup>a</sup> (Beecher)  
   cf Harlot . . . . . 1339<sup>b</sup> (Eager)  
   cf Idolatry . . . . . 1447<sup>b</sup> (Cobern)  
   cf Image . . . . . 1450<sup>a</sup> (Edwards)  
   cf Nehushtan . . . . . 2132<sup>a</sup> (Longacre)  
   Origin of . . . . . 1452<sup>b</sup>  
   cf Palestine, Recent Ex-  
   ploration . . . . . 2222<sup>b</sup> (Cobern)  
   cf Pillar . . . . . 2398<sup>b</sup> (Orr)  
   cf Totemism . . . . . 3000<sup>a</sup> (M. O. Evans)  
 Imagination . . . . . 1456<sup>a</sup> (W. L. Walker)  
 Imagine . . . . . 1456<sup>a</sup> (W. L. Walker)  
 Imalcue . . . . . 1456<sup>a</sup> (Hutchison)  
 Imla, Imlah . . . . . 1456<sup>b</sup>  
 Immaculate Conception . 1456<sup>b</sup> (Sweet)  
   cf Mary (Virgin) . . . . . 2001<sup>b</sup> (Sweet)  
   Not to be confused  
   with Virgin-birth . . . 1456<sup>b</sup>  
   Roman Catholic dog-  
   ma . . . . . 1456<sup>b</sup>  
   cf Virgin-birth . . . . . 3052<sup>a</sup> (Sweet)  
 Immanuel (Emmanuel) . 1457<sup>b</sup> (A. W. Evans)  
   Child prophecy of  
   Isaiah . . . . . 1457<sup>b</sup>  
   cf Isaiah, Book of . . . . 1501<sup>a</sup> (Robinson)  
   cf Messiah . . . . . 2040<sup>a</sup> (Crichton)  
   cf Person of Christ . . . . 2338<sup>a</sup> (Warfield)  
   cf Quotations, NT . . . . 2517<sup>b</sup> (Sweet)  
   Relation to Messianic  
   hope . . . . . 1458<sup>b</sup>  
   cf Shear-jashub . . . . . 2752<sup>b</sup>  
   cf Sign . . . . . 2789<sup>a</sup> (Stuart)  
   cf Virgin . . . . . 3051<sup>b</sup> (Easton)  
   cf Virgin-birth . . . . . 3052<sup>a</sup> (Sweet)  
 Immer . . . . . 1458<sup>b</sup>  
 Immortal, Immortality . 1458<sup>b</sup> (Orr)  
   Biblical doctrine . . . . . 1460<sup>a</sup>  
   Christian doctrine . . . . . 1460<sup>b</sup>  
   Christian hope . . . . . 1460<sup>b</sup>
- Immortal, Immortality—*continued*  
   cf Death . . . . . 811<sup>b</sup> (Bavinek)  
   Doctrine in OT . . . . . 1460<sup>a</sup>  
   Egyptian doctrine . . . . . 1459<sup>a</sup>  
   cf Eschatology of OT . 972<sup>a</sup> (Orr)  
   cf Hell . . . . . 1371<sup>a</sup> (Orr)  
   cf Incorruption . . . . . 1466<sup>b</sup>  
   cf Life . . . . . 1888<sup>a</sup> (Reeve)  
   cf Mortal, Mortality . . . 2083<sup>a</sup>  
   Origin of belief . . . . . 1459<sup>a</sup>  
   cf Punishment, Ever-  
   lasting . . . . . 2501<sup>b</sup>; 2503<sup>b</sup> (Orr)  
   cf Resurrection . . . . . 2562<sup>a</sup> (Easton)  
   cf Retribution . . . . . 2570<sup>a</sup> (M'Caig)  
   cf Sheol . . . . . 2761<sup>a</sup> (Orr)  
 Immutability, Immu-  
 table . . . . . 1461<sup>b</sup>  
   cf Faithful, Faithful-  
   ness . . . . . 1088<sup>b</sup> (Hodge)  
   cf Unchangeable . . . . . 3033<sup>a</sup> (Hodge)  
 Imna . . . . . 1461<sup>b</sup>  
 Imnah . . . . . 1461<sup>b</sup>  
   cf Jimnah . . . . . 1677<sup>b</sup>  
 Imnites (Jimnites) . . . . 1461<sup>b</sup>  
 Impart . . . . . 1461<sup>b</sup>  
   cf Add . . . . . 54<sup>b</sup> (M. O. Evans)  
 Impediment . . . . . 1461<sup>b</sup>  
 Imperial Guard, Roman . 257<sup>b</sup> (Allen)  
 Implead . . . . . 1462<sup>a</sup>  
 Importable . . . . . 1462<sup>a</sup>  
 Importunity . . . . . 1462<sup>a</sup> (Estes)  
 Imposition of Hands . . . 1335<sup>a</sup> (Orr)  
   cf Keys, Power of . . . . . 1794<sup>a</sup> (Carver)  
 Impossible . . . . . 1462<sup>a</sup>  
 Impotent . . . . . 1462<sup>a</sup> (Macalister)  
 Imprisonment  
   cf Prison . . . . . 2456<sup>a</sup> (T. Lewis)  
   cf Punishments . . . . . 2504<sup>b</sup> (Hirsch)  
 Impurity  
   cf Uncleaness . . . . . 3035<sup>b</sup> (Williams)  
 Imputation . . . . . 1462<sup>a</sup> (Hodge)  
   Of Adam's sin . . . . . 1463<sup>a</sup>  
   cf Atonement . . . . . 627<sup>b</sup> (Orr)  
   Basis of doctrines . . . . 1463<sup>a</sup>  
   Of Christ's righteous-  
   ness . . . . . 1464<sup>a</sup>  
   Doctrines of . . . . . 1462<sup>b</sup>  
   cf Justification . . . . . 1782<sup>b</sup> (Faulkner)  
   Of world's sin to  
   Christ . . . . . 1463<sup>b</sup>  
 Imrah . . . . . 1466<sup>a</sup>  
 Imri . . . . . 1466<sup>a</sup>  
 In . . . . . 1466<sup>a</sup> (Orr)  
 In the Lord . . . . . 1466<sup>a</sup> (Edwards)  
 Incantation  
   cf Magic . . . . . 1963<sup>a</sup> (T. W. Davies)  
 Incarnation . . . . . 692<sup>b</sup> (Tisdall)  
   cf Accommodation . . . . . 33<sup>a</sup> (Sweet)  
   cf Johannine Theology . 1699<sup>a</sup> (Law)  
   cf Person of Christ . . . . 2342<sup>b</sup> (Warfield)  
 Incense . . . . . 1466<sup>b</sup> (Orr)  
   cf Altar of Incense . . . . 111<sup>b</sup> (Caldecott)



- Incense—*continued*  
   of Censer . . . . . 587<sup>b</sup> (T. Lewis)  
   of Frankincense . . . . . 1145<sup>a</sup> (Masterman)  
   of Perfume . . . . . 2321<sup>b</sup> (Patch)  
   of Tabernacle . . . . . 2887<sup>b</sup> (Caldecott; Orr)  
   of Temple . . . . . 2930<sup>a</sup> (Caldecott; Orr)  
 Incest . . . . . 747<sup>a</sup> (Hirsch)  
 Incontinency . . . . . 1466<sup>b</sup>  
 Inculpation . . . . . 1466<sup>b</sup>  
   of Immortal, Immor-  
   tality . . . . . 1458<sup>b</sup> (Orr)  
 Increase . . . . . 1466<sup>b</sup> (Miller)  
 India . . . . . 1467<sup>a</sup> (Ewing)  
 Indignities  
   of Punishments . . . . . 2504<sup>b</sup> (Hirsch)  
 Indite . . . . . 1467<sup>a</sup>  
 Infancy, Gospel of the  
   of Apocryphal Gospels 195<sup>a</sup> (Hutchison)  
 Infancy Narrations  
   of Mary (Virgin) . . . . . 2001<sup>b</sup> (Sweet)  
 Infant Baptism  
   of Baptism . . . . . 388<sup>b</sup> (T. M. Lindsay);  
   396<sup>b</sup> (Dau)  
 Infanticide  
   of Crimes . . . . . 747<sup>a</sup> (Hirsch)  
   of Molech . . . . . 2074<sup>a</sup> (Nicol)  
 Infidel . . . . . 1467<sup>a</sup> (Carver)  
 Infinite . . . . . 1467<sup>a</sup> (Orr)  
   of Omnipresence . . . . . 2190<sup>a</sup> (Vos)  
   of Omniscience . . . . . 2191<sup>a</sup> (Vos)  
 Infinitude . . . . . 1467<sup>a</sup> (Orr)  
 Infirmary . . . . . 1468<sup>a</sup> (Macalister)  
 Inflammation . . . . . 1468<sup>a</sup>  
   of Fever . . . . . 1107<sup>b</sup> (Macalister)  
 Influences . . . . . 1468<sup>a</sup> (W. L. Walker)  
 Ingathering, Feast of  
   of Feasts and Fasts . . . . . 1103<sup>a</sup> (E. D. Isaacs)  
 Inhabit . . . . . 1468<sup>a</sup> (Edwards)  
   of Dwell . . . . . 883<sup>b</sup> (Edwards)  
 Inhabitant . . . . . 1468<sup>a</sup> (Edwards)  
 Inheritance . . . . . 1468<sup>b</sup> (Hirsch)  
   of Heir . . . . . 1369<sup>a</sup> (Easton)  
   of Patrimony . . . . . 2264<sup>a</sup> (Mack)  
 Iniquity . . . . . 1468<sup>b</sup> (Edwards)  
 Injoin (Enjoin) . . . . . 952<sup>b</sup>  
 Injurious . . . . . 1469<sup>a</sup>  
 Injury  
   of Crimes . . . . . 745<sup>b</sup> (Hirsch)  
 Ink . . . . . 1469<sup>a</sup> (Richardson)  
   of Ink-horn . . . . . 1469<sup>b</sup> (Richardson)  
   of Pen . . . . . 2297<sup>b</sup> (Patch)  
   of Writing . . . . . 3119<sup>a</sup>; 3122<sup>a</sup> (Richardson)  
 Ink-horn . . . . . 1469<sup>b</sup> (Richardson)  
   of Horn . . . . . 1422<sup>a</sup> (Easton)  
   of Ink . . . . . 1469<sup>a</sup> (Richardson)  
   of Pen . . . . . 2297<sup>b</sup> (Patch)  
   of Print . . . . . 2455<sup>a</sup> (Richardson)  
   of Writing . . . . . 3119<sup>a</sup>; 3122<sup>a</sup> (Richardson)  
 Inn . . . . . 1470<sup>a</sup> (Christie)  
   Earliest . . . . . 1470<sup>a</sup>  
   Public . . . . . 1470<sup>a</sup>
- Inner Man  
   of Inward Man . . . . . 1490<sup>b</sup> (Pratt)  
 Innocence, Innocency,  
   Innocent . . . . . 1470<sup>b</sup> (Forrester)  
 Innocents, Massacre of  
   the . . . . . 1471<sup>a</sup> (Sweet)  
   of Virgin-birth of Jesus  
   Christ . . . . . 3052<sup>a</sup> (Sweet)  
 Inordinate . . . . . 1472<sup>b</sup> (Edwards)  
 Inquire . . . . . 1472<sup>b</sup> (M. O. Evans)  
   of Divination . . . . . 860<sup>a</sup> (T. W. Davies)  
 Inquisition . . . . . 1472<sup>b</sup>  
 Inscription . . . . . 1473<sup>a</sup>  
   of Archaeology . . . . . 226<sup>a</sup> (Kyle)  
   of Assyria . . . . . 290<sup>b</sup> (Sayce)  
   of Babylonia . . . . . 358<sup>b</sup> (Clay)  
 Inscription, Siloam  
   of Siloam . . . . . 2792<sup>b</sup> (Masterman)  
 Insects . . . . . 1473<sup>a</sup> (Day); 1124<sup>a</sup> (Eager)  
   of Locust . . . . . 1907<sup>b</sup> (Day)  
   of Moth . . . . . 2091<sup>b</sup> (Day)  
   of Palmer-worm . . . . . 2236<sup>a</sup>  
   of Sand Flies . . . . . 2688<sup>b</sup>  
   of Scorpion . . . . . 2703<sup>b</sup> (Day)  
   of Spider . . . . . 2840<sup>b</sup> (Day)  
 Inspiration . . . . . 1473<sup>a</sup> (Warfield)  
   of Biblical claims to . . . . . 468<sup>a</sup> (Orr)  
   of Cain . . . . . 538<sup>b</sup> (Farr)  
   Christ's testimony . . . . . 1476<sup>b</sup>  
   Divine activity . . . . . 1479<sup>b</sup>  
   Fulfilment of Scripture 1476<sup>a</sup>  
   Human element . . . . . 1479<sup>a</sup>  
   of Interpretation . . . . . 1489<sup>a</sup> (Schodde)  
   Of NT . . . . . 1483<sup>a</sup>  
   Occurrences in Bible . . . . . 1473<sup>b</sup>  
   of Prophecy . . . . . 2460<sup>a</sup> (Orelli)  
   And Providence . . . . . 1481<sup>a</sup>  
   And Revelation . . . . . 1482<sup>a</sup>  
   of Revelation . . . . . 2577<sup>a</sup> (Warfield)  
   Witness of Apostles . . . . . 1477<sup>a</sup>  
 Instant, Instantly . . . . . 1483<sup>b</sup> (Miller)  
 Instruction  
   of Catechist . . . . . 582<sup>b</sup> (Gerberding)  
   of Education . . . . . 900<sup>b</sup> (Meyer)  
   of Schoolmaster . . . . . 2702<sup>b</sup> (Easton)  
 Instrument . . . . . 1483<sup>b</sup>  
   of Music . . . . . 2094<sup>b</sup> (Millar)  
 Instruments of Music . . . . . 1484<sup>a</sup>  
   of Music . . . . . 2094<sup>b</sup> (Millar)  
 Insurrection . . . . . 1484<sup>a</sup>  
 Integrity . . . . . 1484<sup>a</sup> (W. L. Walker)  
   of Urim and Thum-  
   mim . . . . . 3040<sup>b</sup> (N. Isaacs)  
 Intelligence . . . . . 1484<sup>a</sup>  
 Intend, Intent . . . . . 1484<sup>a</sup> (Miller)  
 Intercession . . . . . 1484<sup>a</sup> (Bevan)  
   Of Christ . . . . . 1487<sup>a</sup>  
   In the Gospels . . . . . 1486<sup>b</sup>  
   By holy men . . . . . 1485<sup>b</sup>  
   Of the Holy Spirit . . . . . 1487<sup>b</sup>  
   of Prayers of Jesus . . . . . 2431<sup>b</sup> (Bevan)

- Intercession of Christ . . . 1487<sup>b</sup> (Bevan)  
   of Intercession . . . . . 1484<sup>a</sup> (Bevan)  
   of Prayers of Jesus . . . 2431<sup>b</sup> (Bevan)  
 Interest . . . . . 1488<sup>b</sup> (Reeve)  
   of Usury . . . . . 3041<sup>b</sup> (Pollard)  
 Intermeddle . . . . . 1489<sup>a</sup> (M. O. Evans)  
 Intermediate State  
   of Eschatology of the  
     NT . . . . . 979<sup>b</sup> (Vos)  
 Interpretation . . . . . 1489<sup>a</sup> (Schodde)  
   of Accommodation . . . . 29<sup>a</sup> (Sweet)  
   of Inspiration . . . . . 1473<sup>a</sup> (Warfield)  
 Interpretation of Chris-  
 tianity  
   of Leviticus . . . . . 1880<sup>a</sup> (Möller)  
 Interpretation of Tongues  
   of Tongues, Gift of . . . 2995<sup>b</sup> (Easton)  
 Interrogation . . . . . 1490<sup>b</sup>  
 Inter-testamental His-  
 tory and Literature  
   of Between the Testa-  
     ments . . . . . 455<sup>a</sup> (Dosker)  
 Intreat, Intreaty . . . . . 1490<sup>b</sup> (Miller)  
 Inward Man . . . . . 1490<sup>b</sup> (Pratt)  
 Inward Part . . . . . 1490<sup>b</sup> (Pratt)  
   of Inward Man . . . . . 1490<sup>b</sup> (Pratt)  
 Iob (Jashub) . . . . . 1491<sup>a</sup>  
 Ioiada  
   of Jehoiada . . . . . 1578<sup>a</sup> (Roberts)  
 Iphdeiah . . . . . 1491<sup>a</sup>  
 Iphtah . . . . . 1491<sup>a</sup>  
 Iphtah-el . . . . . 1491<sup>a</sup> (Ewing)  
 Ir . . . . . 1491<sup>a</sup>  
 Ira . . . . . 1491<sup>a</sup> (Farr)  
   of Gareb . . . . . 1175<sup>a</sup>  
   of Jairite . . . . . 1559<sup>a</sup> (Roberts)  
 Irad . . . . . 1491<sup>a</sup>  
 Iram . . . . . 1491<sup>a</sup>  
 Irenaeus  
   of Mark, Gospel of . . . 1989<sup>b</sup> (Farmer)  
 Ir-ha-heres . . . . . 1491<sup>a</sup> (Kyle)  
   of Heres . . . . . 1376<sup>b</sup> (Masterman)  
   of On . . . . . 2193<sup>a</sup> (Kyle)  
 Iri  
   of Ir . . . . . 1491<sup>a</sup>  
   of Urias . . . . . 3040<sup>a</sup>  
 Irijah . . . . . 1492<sup>a</sup>  
 Ir-nahash . . . . . 1492<sup>a</sup>  
 Iron . . . . . 1492<sup>b</sup> (Patch)  
   of Crafts . . . . . 734<sup>a</sup> (Patch)  
   of Metals . . . . . 2044<sup>a</sup> (Patch)  
 Iron (city) . . . . . 1492<sup>b</sup>  
 Irpeel . . . . . 1492<sup>b</sup>  
 Irreverence  
   of Crime, Crimes . . . . 745<sup>b</sup> (Hirsch)  
 Irrigation . . . . . 1492<sup>b</sup> (Patch)  
   of Agriculture . . . . . 76<sup>a</sup> (Patch)  
   of Garden . . . . . 1174<sup>a</sup> (Patch)  
 Ir-shemesh . . . . . 1493<sup>a</sup>  
   of Beth-shemesh . . . . 453<sup>a</sup> (Kyle)  
   of Heres . . . . . 1376<sup>b</sup> (Masterman)  
 Iru . . . . . 1493<sup>a</sup>  
 Isaac . . . . . 1493<sup>a</sup> (Boyd)  
   of Abraham . . . . . 18<sup>a</sup> (Boyd)  
   Biblical references to . . 1495<sup>a</sup>  
   of Family of, in Genesis . 1208<sup>a</sup> (Möller)  
   of Jacob . . . . . 1550<sup>a</sup> (Boyd)  
   Marriage of . . . . . 1494<sup>a</sup>  
   of Sacrifice of . . . . . 19<sup>a</sup> (Boyd)  
   of Sarah . . . . . 2691<sup>a</sup> (Boyd)  
 Isaac, Testament of  
   of Apocalyptic Litera-  
     ture . . . . . 161<sup>b</sup> (J. E. H. Thomson)  
 Isaiah . . . . . 1495<sup>b</sup> (Robinson)  
   Book of . . . . . 1497<sup>b</sup>  
     Analysis . . . . . 1497<sup>b</sup>  
     Arrangement of . . . . 1503<sup>a</sup>  
     Contents . . . . . 1497<sup>b</sup>  
     Critical problem . . . . 1504<sup>a</sup>  
     Criticism . . . . . 1504<sup>a</sup>  
     of Immanuel . . . . . 1457<sup>b</sup> (A. W. Evans)  
     Recent views . . . . . 1504<sup>b</sup>  
     Woes . . . . . 1500<sup>a</sup>  
   of Dial of Ahaz . . . . . 841<sup>a</sup> (Maunder)  
   of Hezekiah . . . . . 1386<sup>a</sup> (Genung)  
   of Judah . . . . . 1761<sup>b</sup> (Weir)  
   Literary genius . . . . . 1496<sup>a</sup>  
   Martyrdom of . . . . . 1496<sup>a</sup>  
   of Messages to Ahaz . . . 81<sup>b</sup> (Caldecott)  
   of Messiah . . . . . 2040<sup>a</sup> (Crichton)  
   of Micah . . . . . 2046<sup>b</sup> (Orelli)  
   Name . . . . . 1495<sup>b</sup>  
   of Palestine . . . . . 2219<sup>a</sup> (Conder)  
   Personal history and  
     call . . . . . 1495<sup>b</sup>  
   Prophecies . . . . . 1503<sup>a</sup>  
   Prophetic ministry . . . 1496<sup>a</sup>  
   of Servant of Jehovah  
     (The Lord) . . . . . 2739<sup>a</sup> (Hough)  
   Times of . . . . . 1496<sup>a</sup>  
 Isaiah, Ascension of  
   of Apocalyptic Litera-  
     ture . . . . . 161<sup>b</sup> (J. E. H. Thomson)  
 Iscah . . . . . 1508<sup>b</sup>  
 Iscariot  
   of Ish . . . . . 1508<sup>b</sup>  
   of Judas Iscariot . . . . 1765<sup>b</sup> (Kerr)  
 Isdael (Giddel) . . . . . 1508<sup>b</sup>  
 Ish . . . . . 1508<sup>b</sup>  
   of Eshban . . . . . 997<sup>a</sup>  
   of Ishtob . . . . . 1511<sup>a</sup>  
 Ishbaal  
   of Ish-bosheth . . . . . 1508<sup>b</sup> (Breslich)  
 Ishbah . . . . . 1508<sup>b</sup>  
 Ishbak . . . . . 1508<sup>b</sup>  
 Ishbi-benob . . . . . 1508<sup>b</sup>  
 Ish-bosheth . . . . . 1508<sup>b</sup> (Breslich)  
   of Ishvi . . . . . 1511<sup>a</sup>  
   of Mephibosheth . . . . 2033<sup>b</sup> (Wallace)  
   of Saul . . . . . 2699<sup>b</sup> (Weir)  
 Ishhod . . . . . 1508<sup>b</sup>  
   of Ishod . . . . . 1511<sup>a</sup>  
 Ishi . . . . . 1509<sup>a</sup>

- Ishi (person) . . . . . 1509<sup>a</sup> (Farr)
- Ishiah  
 of Isshiah . . . . . 1542<sup>b</sup>
- Ishijah  
 cf Isshijah . . . . . 1542<sup>b</sup>
- Ishma . . . . . 1509<sup>a</sup>
- Ishmael (Greek) . . . . . 1510<sup>b</sup>
- Ishmael (Hebrew) . . . . . 1509<sup>a</sup> (Baur)  
 of Gedaliah . . . . . 1181<sup>a</sup> (Crichton)  
 of Ismael . . . . . 1511<sup>b</sup>  
 of Sarah . . . . . 2691<sup>a</sup> (Boyd)  
 Son of Abraham . . . . . 1509<sup>a</sup>  
 Son of Nethaniah . . . . . 1510<sup>a</sup>
- Ishmaelites . . . . . 1510<sup>a</sup> (Porter)
- Ishmaiah . . . . . 1510<sup>b</sup>
- Ishmeelites  
 cf Ishmaelites . . . . . 1510<sup>b</sup> (Porter)
- Ishmerai . . . . . 1510<sup>b</sup>
- Ishod (Ishhod) . . . . . 1511<sup>a</sup>
- Ishpah . . . . . 1511<sup>a</sup>
- Ishpan . . . . . 1511<sup>a</sup>
- Ish-sechel . . . . . 1511<sup>a</sup>
- Ishtar . . . . . 371<sup>a</sup> (Rogers)
- Ishtob . . . . . 1511<sup>a</sup>  
 cf Ish . . . . . 1508<sup>b</sup>
- Ishuah . . . . . 1511<sup>a</sup>  
 cf Ishvah . . . . . 1511<sup>a</sup>  
 of Ishvi . . . . . 1511<sup>a</sup>
- Ishuai . . . . . 1511<sup>a</sup>  
 cf Ishvi . . . . . 1511<sup>a</sup>
- Ishui (Ishuai) . . . . . 1511<sup>a</sup>
- Ishvah . . . . . 1511<sup>a</sup>
- Ishvi . . . . . 1511<sup>a</sup>  
 cf Ish-bosheth . . . . . 1508<sup>b</sup> (Breslich)
- Ishvites (Ishvi) . . . . . 1511<sup>a</sup>
- Island . . . . . 1511<sup>a</sup> (Day)  
 cf Arvad . . . . . 261<sup>a</sup> (Porter)  
 cf Coast . . . . . 672<sup>a</sup> (Day)  
 cf Jackal . . . . . 1548<sup>a</sup> (Day)  
 cf Wolf . . . . . 3099<sup>b</sup> (Day)
- Isle (Island) . . . . . 1511<sup>a</sup> (Day)
- Isles of the Gentiles . . . . . 1511<sup>b</sup>  
 cf Table of Nations . . . . . 2898<sup>b</sup> (Pinches)
- Ismachiah . . . . . 1511<sup>b</sup>  
 cf Semachiah . . . . . 2717<sup>a</sup>
- Ismael  
 cf Ishmael (Greek) . . . . . 1510<sup>b</sup>
- Ismaerus (Omaerus) . . . . . 1511<sup>b</sup>; 2188<sup>b</sup>
- Ismaiah  
 cf Ishmaiah . . . . . 1510<sup>b</sup>
- Ispah  
 cf Ishpah . . . . . 1511<sup>a</sup>
- Israel  
 cf Jacob . . . . . 1549<sup>a</sup> (Boyd)
- Israel, History of the  
 People . . . . . 1511<sup>b</sup> (Orelli)  
 cf Calf, Golden . . . . . 542<sup>b</sup> (Cobern); 1275<sup>a</sup>  
 cf In Canaan . . . . . 912<sup>a</sup> (Petrie)  
 Chronology . . . . . 1520<sup>a</sup>  
 Divided kingdoms, the 1520<sup>a</sup>  
 Division of the nation 1519<sup>b</sup>  
 Downfall of Judah . . . . . 1525<sup>a</sup>
- Israel, History of the People—*continued*  
 In Egypt . . . . . 1514<sup>b</sup>  
 Exile, the . . . . . 1525<sup>a</sup>  
 cf Gedaliah . . . . . 1181<sup>a</sup> (Crichton)  
 Greek period of . . . . . 1527<sup>a</sup>  
 cf Asmoneans . . . . . 283<sup>a</sup> (Dosker)  
 cf Maccabaeus . . . . . 1946<sup>a</sup> (Hutchison)  
 cf Israel, Kingdom of . . . . . 1528<sup>b</sup> (Weir)  
 cf Israel, Religion of . . . . . 1530<sup>b</sup> (Orelli)  
 cf Josephus Flavius . . . . . 1742<sup>a</sup> (Wenley)  
 Kings . . . . . 1520<sup>b</sup>  
 Leadership of Moses . . . . . 1515<sup>b</sup>  
 The literary prophets . . . . . 1522<sup>b</sup>  
 Maccabees, the . . . . . 1527<sup>b</sup>  
 Moses . . . . . 1515<sup>a</sup>  
 cf Israel, Religion of . . . . . 1534<sup>b</sup> (Orelli)  
 Origins . . . . . 1513<sup>b</sup>  
 Period of the Judges . . . . . 1517<sup>b</sup>  
 cf Providence . . . . . 2477<sup>b</sup> (Tillett)  
 Religious character of . . . . . 1512<sup>b</sup>  
 Return and restora-  
 tion . . . . . 1526<sup>b</sup>  
 Roman period . . . . . 1527<sup>b</sup>  
 cf Slave, Slavery . . . . . 2815<sup>a</sup> (Raffety)  
 Sources . . . . . 1512<sup>a</sup>  
 cf Tribes of . . . . . 1758<sup>b</sup> (Weir)  
 United kingdom . . . . . 1518<sup>b</sup>
- Israel, Kingdom of . . . . . 1528<sup>b</sup> (Weir)  
 Battle of Karkar . . . . . 1529<sup>b</sup>  
 Decline and fall . . . . . 1530<sup>a</sup>  
 Early dynasties . . . . . 1528<sup>a</sup>  
 cf Israel, History of the  
 People . . . . . 1511<sup>b</sup>; 1522<sup>a</sup> (Orelli)  
 cf Judah, Kingdom of . . . . . 1758<sup>a</sup> (Weir)  
 cf Palestine . . . . . 2217<sup>a</sup> (Conder)  
 Revolution of Jehu . . . . . 1529<sup>b</sup>  
 Syrian wars . . . . . 1529<sup>a</sup>
- Israel, Religion of . . . . . 1530<sup>b</sup> (Orelli)  
 Amos and Hosea . . . . . 1538<sup>b</sup>  
 cf Apocalyptic Litera-  
 ture . . . . . 161<sup>b</sup> (J. E. H. Thomson)  
 Before eighth century . . . . . 1536<sup>b</sup>  
 Elijah and Elisha . . . . . 1538<sup>a</sup>  
 Exile, the . . . . . 1539<sup>b</sup>  
 God, conception of . . . . . 1533<sup>b</sup>  
 cf Hope . . . . . 1419<sup>b</sup> (Easton)  
 cf Israel, History of . . . . . 1511<sup>b</sup> (Orelli)  
 Moses, teachings of . . . . . 1534<sup>b</sup>  
 Post-exilic period . . . . . 1540<sup>a</sup>  
 Pre-Mosaic period . . . . . 1531<sup>b</sup>  
 Psalms, teachings of . . . . . 1537<sup>a</sup>  
 cf Semites, Semitic Re-  
 ligion . . . . . 2717<sup>a</sup> (Mack)  
 cf Totemism . . . . . 3000<sup>a</sup> (M. O. Evans)
- Israelite, Israelitish . . . . . 1541<sup>b</sup>
- Issachar . . . . . 1541<sup>b</sup> (Ewing)  
 cf Galilee . . . . . 1163<sup>a</sup> (Ewing)  
 cf Numbers, Book of . . . . . 2163<sup>a</sup> (Whitelaw)
- Isshiah . . . . . 1542<sup>b</sup>
- Isshijah (Aseas) . . . . . 1542<sup>b</sup>
- Issue . . . . . 1542<sup>b</sup>
- Issue (of Blood) . . . . . 1542<sup>b</sup> (Macalister)

- Issues . . . . . 1542<sup>b</sup>  
 Istalcurus . . . . . 1542<sup>b</sup>  
 Isuah  
   cf Ishvah . . . . . 1511<sup>a</sup>  
 Isui  
   cf Ishvi . . . . . 1511<sup>a</sup>  
 Isvah  
   cf Ishvah . . . . . 1511<sup>a</sup>  
 Itala Version  
   cf Vulgate . . . . . 3058<sup>b</sup> (Angus)  
 Italian Band  
   cf Army, Roman . . . . . 258<sup>b</sup> (Allen)  
   cf Band . . . . . 382<sup>b</sup> (Nicol)  
 Italy . . . . . 1542<sup>b</sup> (Allen)  
   cf Rome . . . . . 2618<sup>a</sup> (Allen)  
 Itch . . . . . 1543<sup>a</sup> (Macalister)  
 Ithai  
   cf Ittai . . . . . 1543<sup>b</sup> (Reeve)  
 Ithamar . . . . . 1543<sup>a</sup> (Whitelaw)  
   cf Zadok . . . . . 3129<sup>b</sup> (Whitelaw)  
 Ithiel . . . . . 1543<sup>a</sup>  
   cf Ithiel and Ucal . . . . . 1543<sup>b</sup> (Genung)  
   cf Ucal . . . . . 3032<sup>a</sup> (Roberts)  
 Ithiel and Ucal . . . . . 1543<sup>b</sup> (Genung)  
   cf Ithiel . . . . . 1543<sup>a</sup>  
 Ithlah . . . . . 1543<sup>b</sup>  
 Ithmah . . . . . 1543<sup>b</sup>  
 Ithnan . . . . . 1543<sup>b</sup>  
 Ithra . . . . . 1543<sup>b</sup>  
 Ithran . . . . . 1543<sup>b</sup>  
 Ithream . . . . . 1543<sup>b</sup>  
 Ithrite . . . . . 1543<sup>b</sup>  
 Ittah-kazin . . . . . 1543<sup>b</sup>  
 Ittai . . . . . 1543<sup>b</sup> (Reeve)  
 Ituraea (Iturea) . . . . . 1544<sup>a</sup> (Ewing)  
   cf Jetur . . . . . 1675<sup>a</sup>  
 Ituraeans . . . . . 1544<sup>a</sup> (Ewing)  
 Ivah  
   cf Hena . . . . . 1374<sup>b</sup> (Ewing)  
   cf Ivvah . . . . . 1544<sup>b</sup> (Pinches)  
 Ivory . . . . . 1544<sup>b</sup> (Day)  
 Ivory, Tower of . . . . . 1544<sup>b</sup>  
 Ivvah . . . . . 1544<sup>b</sup> (Pinches)  
   cf Sepharvaim . . . . . 2721<sup>b</sup> (Pinches)  
 Ivy . . . . . 1545<sup>a</sup> (Hutchison)  
 Iyar  
   cf Iyyar . . . . . 1545<sup>b</sup>  
 Iye-abarim . . . . . 1545<sup>a</sup>  
 Iyim . . . . . 1545<sup>a</sup>  
 Iyyar . . . . . 1545<sup>b</sup>  
   cf Calendar . . . . . 541<sup>b</sup> (Porter)  
 Izehar  
   cf Izhar . . . . . 1545<sup>b</sup>  
 Izhar . . . . . 1545<sup>b</sup>  
 Izharites . . . . . 1545<sup>b</sup>  
 Izliah (Jezliah) . . . . . 1545<sup>b</sup>  
 Izrahiah . . . . . 1545<sup>b</sup>  
 Izrahite . . . . . 1545<sup>b</sup>  
 Izri . . . . . 1545<sup>b</sup>  
   cf Zeri . . . . . 3147<sup>b</sup>  
 Izziah . . . . . 1545<sup>b</sup>
- Jaakan  
   cf Beeroth-bene-jaakan . . . . . 424<sup>b</sup>  
 Jaakobah . . . . . 1545<sup>a</sup>  
 Jaala . . . . . 1545<sup>a</sup>  
 Jaalam  
   cf Jalam . . . . . 1559<sup>b</sup>  
 Jaanai  
   cf Janai . . . . . 1568<sup>a</sup>  
 Jaar . . . . . 1545<sup>b</sup>  
   cf Kiriath-jearim . . . . . 1811<sup>b</sup> (Masterman)  
 Jaare-oregim . . . . . 1545<sup>b</sup> (Roberts)  
 Jaareshiah . . . . . 1546<sup>a</sup>  
 Jaasai (Jaasau, Jaasu) . . . . . 1546<sup>a</sup>  
 Jaasiel . . . . . 1546<sup>a</sup>  
   cf Jasiel . . . . . 1571<sup>a</sup>  
 Jaasu . . . . . 1546<sup>a</sup>  
 Jaazaniah . . . . . 1546<sup>a</sup> (Roberts)  
   cf Jezaniah . . . . . 1675<sup>b</sup>  
 Jaazer  
   cf Jazer . . . . . 1572<sup>a</sup> (Ewing)  
 Jaaziah . . . . . 1546<sup>a</sup>  
 Jaaziel . . . . . 1546<sup>a</sup>  
 Jabal . . . . . 1546<sup>b</sup> (Roberts)  
   cf Jubal . . . . . 1756<sup>a</sup>  
 Jabbok . . . . . 1546<sup>b</sup> (Ewing)  
   cf Gilead . . . . . 1230<sup>b</sup> (Ewing)  
 Jabesh . . . . . 1546<sup>b</sup>  
   cf Jabesh-gilead . . . . . 1546<sup>b</sup> (Ewing)  
 Jabesh-gilead . . . . . 1546<sup>b</sup> (Ewing)  
   cf Saul . . . . . 2698<sup>a</sup> (Weir)  
 Jabez . . . . . 1547<sup>a</sup>  
 Jabin . . . . . 1547<sup>a</sup> (E. D. Isaacs)  
 Jabneel (Jabneh) . . . . . 1547<sup>a</sup> (Porter)  
 Jacan . . . . . 1547<sup>b</sup>  
 Jachin . . . . . 1547<sup>b</sup> (Crichton)  
 Jachin and Boaz . . . . . 1547<sup>b</sup> (Caldecott)  
   cf Lily-work . . . . . 1893<sup>b</sup>  
   cf Network . . . . . 2140<sup>a</sup>  
   cf Pillar . . . . . 2398<sup>b</sup> (Orr)  
   cf Temple . . . . . 2932<sup>a</sup> (Caldecott; Orr)  
 Jacimus  
   cf Alcimus . . . . . 89<sup>b</sup> (Mack)  
 Jacinth  
   cf Hyacinth . . . . . 1443<sup>b</sup>  
   cf Stones, Precious . . . . . 2856<sup>a</sup> (Fletcher)  
 Jackal . . . . . 1548<sup>a</sup> (Day)  
   cf Dragon . . . . . 873<sup>a</sup> (Day)  
   cf Fox . . . . . 1144<sup>a</sup> (Day)  
   cf Island . . . . . 1511<sup>a</sup> (Day)  
   cf Jackal's Well . . . . . 1548<sup>b</sup> (Masterman)  
   cf Satyr . . . . . 2697<sup>a</sup> (Day)  
   cf Sea-monster . . . . . 2707<sup>a</sup> (Day)  
   cf Whale . . . . . 3082<sup>a</sup> (Day)  
   cf Wild Beast . . . . . 3084<sup>a</sup> (Day)  
   cf Wolf . . . . . 3099<sup>b</sup> (Day)  
   cf Zoölogy . . . . . 3155<sup>a</sup> (Day)  
 Jackal's Well . . . . . 1548<sup>b</sup> (Masterman)  
   cf Hinnom, Valley of . . . . . 1393<sup>b</sup> (Masterman)  
   cf Jerusalem . . . . . 1597<sup>b</sup> (Masterman)  
 Jacob (father of Joseph,  
   husband of Mary) . . . . . 1556<sup>a</sup>  
 Jacob (patriarch) . . . . . 1549<sup>a</sup> (Boyd); 1556<sup>a</sup>

Jacob—*continued*

- of Abraham . . . . . 18<sup>a</sup> (Boyd)  
 Antiquity of name . . . . . 1549<sup>a</sup>  
 At Beersheba . . . . . 1552<sup>a</sup>  
 At Bethel . . . . . 1550<sup>b</sup>; 1551<sup>b</sup>  
 Blessing and death . . . . . 1552<sup>a</sup>  
 Contrast with Esau . . . . . 1553<sup>b</sup>  
 Critical reconstructions . . . . . 1555<sup>a</sup>  
 Dealings with Esau . . . . . 1550<sup>a</sup>  
 Development of character . . . . . 1552<sup>b</sup>  
 In Egypt . . . . . 1552<sup>a</sup>  
 Epiphanies to . . . . . 1553<sup>a</sup>  
 cf And Esau . . . . . 478<sup>b</sup> (J. M. Wilson)  
 cf Family of, in Genesis . . . . . 1208<sup>a</sup> (Möller)  
 In Haran . . . . . 1550<sup>a</sup>  
 Importance among the patriarchs . . . . . 1549<sup>b</sup>  
 And Israel . . . . . 1554<sup>a</sup>  
 Meaning of name . . . . . 1549<sup>a</sup>  
 As myth or deity . . . . . 1555<sup>b</sup>  
 Natural qualities . . . . . 1552<sup>b</sup>  
 cf Palestine . . . . . 2210<sup>b</sup> (Conder)  
 References to, in NT. . . . . 1554<sup>b</sup>  
 References to, in OT. . . . . 1554<sup>b</sup>  
 Relations with God . . . . . 1553<sup>b</sup>  
 Residence in Canaan . . . . . 1551<sup>a</sup>  
 Return to Canaan . . . . . 1551<sup>a</sup>  
 As saga hero . . . . . 1555<sup>b</sup>  
 Term denoting Israelites . . . . . 1556<sup>a</sup>  
 Use of Divine names in story of . . . . . 1553<sup>b</sup>
- Jacob, Testament of  
 cf Apocalyptic Literature . . . . . 161<sup>b</sup> (J. E. H. Thomson)
- Jacob's Well . . . . . 1556<sup>b</sup> (Ewing)  
 Churches on site of . . . . . 1557<sup>a</sup>  
 Description . . . . . 1557<sup>a</sup>  
 Location . . . . . 1556<sup>b</sup>  
 cf Shechem . . . . . 2755<sup>a</sup> (Ewing)  
 cf Sychar . . . . . 2876<sup>b</sup> (Ewing)
- Jacobus (Akkub) . . . . . 1557<sup>a</sup>  
 Jada . . . . . 1557<sup>a</sup>  
 Jadau . . . . . 1557<sup>a</sup>  
 cf Iddo . . . . . 1447<sup>b</sup> (Crannell)
- Jaddai  
 cf Iddo . . . . . 1447<sup>b</sup> (Crannell)
- Jaddua . . . . . 1557<sup>a</sup> (Crichton)
- Jaddus . . . . . 1557<sup>b</sup>  
 cf Barzillai . . . . . 410<sup>b</sup> (Rees)
- Jadon . . . . . 1557<sup>b</sup> (Crichton)
- Jael . . . . . 1557<sup>b</sup> (Schenk); 814<sup>a</sup> (Margolis)  
 Breach of hospitality . . . . . 1557<sup>b</sup>  
 Praise of . . . . . 1558<sup>a</sup>  
 cf Sisera . . . . . 2812<sup>b</sup> (Schenk)
- Jagur . . . . . 1558<sup>a</sup>
- Jah  
 cf God, Names of . . . . . 1264<sup>b</sup> (Mack)
- Jahath . . . . . 1558<sup>b</sup> (Crichton)
- Jahaz . . . . . 1558<sup>a</sup> (Ewing)  
 cf Kedemoth . . . . . 1790<sup>b</sup>
- Jahaziah (Jahzeiah) . . . . . 1559<sup>a</sup> (Roberts)
- Jahaziel . . . . . 1558<sup>b</sup> (Roberts)  
 cf Uzziel . . . . . 3044<sup>b</sup> (Roberts)  
 cf Zechariah . . . . . 3136<sup>a</sup> (Easton)
- Jahdai . . . . . 1558<sup>b</sup>
- Jahdiel . . . . . 1558<sup>b</sup>
- Jahdo . . . . . 1558<sup>b</sup>
- Jahleel . . . . . 1558<sup>b</sup>
- Jahleelites . . . . . 1558<sup>b</sup>
- Jahmai . . . . . 1558<sup>b</sup>
- Jahweh  
 cf God, Names of . . . . . 1264<sup>b</sup> (Mack)
- Jahzah (Jahaz) . . . . . 1558<sup>a</sup>
- Jahzeel . . . . . 1558<sup>b</sup>
- Jahzeelites . . . . . 1559<sup>a</sup>
- Jahzeiah . . . . . 1559<sup>a</sup> (Roberts)  
 cf Jonathan . . . . . 1730<sup>b</sup> (Roberts)
- Jahzerah . . . . . 1559<sup>a</sup>
- Jahziel (Jahzeel) . . . . . 1558<sup>b</sup>
- Jailer  
 cf Prison . . . . . 2456<sup>a</sup> (T. Lewis)
- Jair . . . . . 1559<sup>a</sup> (Crichton)  
 cf Havvoth-jair . . . . . 1345<sup>a</sup> (Ewing)
- Jairite . . . . . 1559<sup>a</sup> (Roberts)  
 cf Ira . . . . . 1491<sup>a</sup> (Farr)
- Jairus . . . . . 1559<sup>b</sup> (Kerr)
- Jairus (Apoc) . . . . . 1559<sup>b</sup>  
 cf Airus . . . . . 88<sup>b</sup>  
 cf Jair . . . . . 1559<sup>a</sup> (Crichton)
- Jakan (Akan) . . . . . 88<sup>b</sup>
- Jakeh . . . . . 1559<sup>b</sup> (Crichton)  
 cf Agur . . . . . 78<sup>a</sup> (Genung)
- Jakim . . . . . 1559<sup>b</sup>  
 cf Eliakim . . . . . 929<sup>a</sup> (S. F. Hunter)
- Jalam (Jaalam) . . . . . 1559<sup>b</sup>
- Jalon . . . . . 1559<sup>b</sup>
- Jambres  
 cf Jannes and Jambres . . . . . 1568<sup>a</sup> (Rutherford)
- Jambri . . . . . 1559<sup>b</sup>
- James (brother of the Lord) . . . . . 1561<sup>a</sup> (Kerr)  
 In Apocryphal literature . . . . . 1561<sup>b</sup>  
 Appearance of Jesus to . . . . . 1666<sup>b</sup>  
 Author of Epistle of James . . . . . 1561<sup>b</sup>  
 cf Brethren of the Lord . . . . . 518<sup>b</sup> (Jacobs)  
 In the Epistles . . . . . 1561<sup>a</sup>  
 In the Gospels . . . . . 1561<sup>a</sup>  
 cf James, Epistle of . . . . . 1562<sup>a</sup> (Hayes)  
 cf Joseph, Husband of Mary . . . . . 1740<sup>b</sup> (Kerr)
- James (the Less; son of Alphaeus) . . . . . 1561<sup>a</sup> (Kerr)  
 cf Brethren of the Lord . . . . . 518<sup>b</sup> (Jacobs)

- James (son of Alphaeus)—*continued*  
 Called James the Less 1561<sup>a</sup>  
 cf Simon the Canaan-  
 ite, or Cananaean,  
 or Zealot . . . . . 2798<sup>b</sup> (Kerr)
- James (son of Zebedee) . . . . . 1560<sup>a</sup> (Kerr)  
 In Apocryphal litera-  
 ture . . . . . 1560<sup>b</sup>  
 Apostleship . . . . . 1560<sup>a</sup>  
 cf Brethren of the Lord 518<sup>b</sup> (Jacobs)  
 Call by Jesus . . . . . 1556<sup>a</sup>  
 cf Zebedee . . . . . 3134<sup>a</sup>
- James, Epistle of . . . . . 1562<sup>a</sup> (Hayes)  
 Authoritative note . . . . . 1562<sup>b</sup>  
 Authorship . . . . . 1563<sup>a</sup>  
 In church history . . . . . 1566<sup>a</sup>  
 Comparison with Jesus'  
 style . . . . . 1564<sup>b</sup>  
 Date . . . . . 1565<sup>b</sup>  
 In the Fathers . . . . . 1566<sup>a</sup>  
 Figures of speech . . . . . 1564<sup>a</sup>  
 cf James (brother of  
 the Lord) . . . . . 1561<sup>b</sup> (Kerr)  
 Jesus and James . . . . . 1567<sup>a</sup>  
 Jewish character . . . . . 1562<sup>a</sup>  
 cf Justification . . . . . 1785<sup>b</sup> (Faulkner)  
 Modern message . . . . . 1567<sup>a</sup>  
 Practical nature . . . . . 1562<sup>b</sup>  
 Style . . . . . 1563<sup>b</sup>  
 Vividness . . . . . 1564<sup>a</sup>
- James, Protevangelium  
 of  
 cf Apocryphal Gospels 195<sup>a</sup> (Hutchison)
- Jamin (Iadinus) . . . . . 1567<sup>b</sup>; 1446<sup>a</sup>
- Jaminites . . . . . 1568<sup>a</sup>
- Jamlech . . . . . 1568<sup>a</sup>
- Jamnia  
 cf Jabneel . . . . . 1547<sup>a</sup> (Porter)
- Jamnites . . . . . 1568<sup>a</sup>
- Janai (Jaanaï) . . . . . 1568<sup>a</sup>
- Jangling . . . . . 1568<sup>a</sup>
- Janim . . . . . 1568<sup>a</sup>  
 cf Janum . . . . . 1568<sup>b</sup>
- Jannai . . . . . 1568<sup>a</sup>
- Jannes and Jambres . . . . . 1568<sup>a</sup> (Rutherford)
- Jannes and Jambres,  
 Book of . . . . . 1568<sup>b</sup>
- Janoah . . . . . 1568<sup>b</sup> (Ewing)
- Janum . . . . . 1568<sup>b</sup>  
 cf Janim . . . . . 1568<sup>a</sup>
- Japheth . . . . . 1568<sup>b</sup> (Pinches)  
 Connection with Greek  
 Iapetos . . . . . 1569<sup>a</sup>  
 cf Ham . . . . . 1323<sup>b</sup> (Pinches)  
 Meaning of word . . . . . 1568<sup>b</sup>  
 cf Shem . . . . . 2759<sup>a</sup> (Pinches)  
 cf Table of Nations . . . . . 2898<sup>b</sup> (Pinches)
- Japheth (place) . . . . . 1569<sup>a</sup>
- Japhia . . . . . 1569<sup>a</sup> (Crichton)
- Japhia (place) . . . . . 1569<sup>a</sup>
- Japhlet . . . . . 1569<sup>a</sup>
- Japhleti . . . . . 1569<sup>a</sup>
- Japho . . . . . 1569<sup>a</sup>  
 cf Joppa . . . . . 1731<sup>b</sup> (Ewing)
- Jar  
 cf Barrel . . . . . 406<sup>a</sup> (Eager)
- Jarah . . . . . 1569<sup>b</sup>  
 cf Jehoaddah . . . . . 1574<sup>b</sup>
- Jareb . . . . . 1569<sup>b</sup> (Crichton)  
 Epithet of Assyrian  
 king . . . . . 1569<sup>b</sup>  
 Historical reference . . . . . 1569<sup>b</sup>
- Jared . . . . . 1570<sup>a</sup>; 139<sup>a</sup> (Davis)  
 cf Jered . . . . . 1587<sup>b</sup>
- Jaresiah  
 cf Jaareshiah . . . . . 1546<sup>a</sup>
- Jarha . . . . . 1570<sup>a</sup>
- Jarib . . . . . 1570<sup>a</sup>  
 cf Joribus . . . . . 1736<sup>b</sup>
- Jarimoth . . . . . 1570<sup>a</sup>
- Jarmuth . . . . . 1570<sup>a</sup> (Masterman)  
 cf Ramoth . . . . . 2529<sup>a</sup>  
 cf Remeth . . . . . 2557<sup>a</sup>
- Jaroah . . . . . 1570<sup>a</sup>
- Jasaelus . . . . . 1570<sup>a</sup>
- Jashar  
 cf Jeshurun . . . . . 1623<sup>a</sup> (Roberts)
- Jashar, Book of . . . . . 1570<sup>a</sup> (Orr)  
 cf Beth-horon, Battle  
 of . . . . . 446<sup>b</sup> (Maunder)
- Jashen (Hashem) . . . . . 1570<sup>b</sup> (Roberts)  
 cf Jonathan . . . . . 1730<sup>b</sup> (Roberts)
- Jasher, Book of  
 cf Beth-horon, Battle  
 of . . . . . 446<sup>b</sup> (Maunder)  
 cf Jashar, Book of . . . . . 1570<sup>a</sup> (Orr)
- Jashobeam . . . . . 1570<sup>b</sup> (Crichton)
- Jashub . . . . . 1571<sup>a</sup>  
 cf Iob . . . . . 1491<sup>a</sup>  
 cf Jashubites . . . . . 1571<sup>a</sup>  
 cf Jasubus . . . . . 1571<sup>b</sup>  
 cf Shear-jashub . . . . . 2752<sup>b</sup>
- Jashubi-lehem . . . . . 1571<sup>a</sup>
- Jashubites . . . . . 1571<sup>a</sup>  
 cf Jashub . . . . . 1571<sup>a</sup>
- Jasiel . . . . . 1571<sup>a</sup>  
 cf Jaasiel . . . . . 1546<sup>a</sup>
- Jason . . . . . 1571<sup>a</sup> (Hutchison)
- Jason . . . . . 1571<sup>b</sup> (S. F. Hunter); 17<sup>a</sup>  
 (Hirsch)  
 Companion of Paul . . . . . 1571<sup>b</sup>  
 Host of Paul in Thessa-  
 lonica . . . . . 1571<sup>b</sup>
- Jasper (Jaspis)  
 cf Stones, Precious . . . . . 2856<sup>a</sup> (Fletcher)
- Jasubus . . . . . 1571<sup>b</sup>  
 cf Jashub . . . . . 1571<sup>a</sup>
- Jatal  
 cf Atar . . . . . 317<sup>a</sup>
- Jathan . . . . . 1571<sup>b</sup>  
 cf Jonathas . . . . . 1731<sup>b</sup>
- Jathbath  
 cf Jotbathah . . . . . 1754<sup>a</sup>

- Jathniel . . . . . 1571<sup>b</sup>  
 Jattir . . . . . 1571<sup>b</sup> (Masterman)  
 Javan . . . . . 1572<sup>a</sup> (Roberts)  
   cf Greece . . . . . 1295<sup>a</sup> (Heidel)  
   cf Greece, Sons of . . . . . 1305<sup>a</sup>  
 Javelin . . . . . 252<sup>a</sup> (Nicol)  
 Jaw . . . . . 1572<sup>a</sup> (M. O. Evans)  
   Figurative use . . . . . 1572<sup>a</sup>  
   cf Hook . . . . . 1419<sup>a</sup> (Easton)  
   cf Leviathan . . . . . 1868<sup>b</sup> (Day)  
 Jawbone . . . . . 1572<sup>a</sup> (M. O. Evans)  
   cf Ramath-lehi . . . . . 2528<sup>b</sup> (Ewing)  
 Jaw Teeth . . . . . 1572<sup>a</sup> (M. O. Evans)  
 Jazer . . . . . 1572<sup>a</sup> (Ewing)  
 Jaziz . . . . . 1572<sup>b</sup>  
 Jealousy . . . . . 1572<sup>b</sup> (Forrester)  
   cf Adultery . . . . . 63<sup>a</sup> (Margolis)  
   cf Thigh . . . . . 2972<sup>b</sup> (Easton)  
 Jealousy, Image of  
   cf Images . . . . . 1452<sup>a</sup> (Coburn)  
 Jealousy, Water of  
   cf Adultery . . . . . 63<sup>a</sup> (Margolis)  
 Jearim, Mount . . . . . 1572<sup>b</sup>  
   cf Chesalon . . . . . 604<sup>b</sup>  
 Jeatherai, Jeaterai . . . . . 1572<sup>b</sup>  
 Jeberechiah . . . . . 1573<sup>a</sup>  
 Jebus . . . . . 1573<sup>a</sup> (Masterman; Orr)  
   cf Jebusite . . . . . 1573<sup>a</sup> (Orr)  
   cf Jerusalem . . . . . 1595<sup>b</sup> (Masterman)  
 Jebusi . . . . . 1573<sup>a</sup> (Orr)  
 Jebusite . . . . . 1573<sup>a</sup> (Orr)  
   cf Jebus . . . . . 1573<sup>a</sup> (Masterman; Orr)  
   cf Jerusalem . . . . . 1595<sup>b</sup> (Masterman)  
 Jecamiah  
   cf Jekamiah . . . . . 1586<sup>b</sup>  
 Jechiliah . . . . . 1573<sup>b</sup>  
   cf Jecholiah . . . . . 1573<sup>b</sup>  
 Jecholiah . . . . . 1573<sup>b</sup>  
 Jechonias . . . . . 1573<sup>b</sup>  
 Jecoliah . . . . . 1573<sup>b</sup>  
   cf Jechiliah . . . . . 1573<sup>b</sup>  
   cf Jecholiah . . . . . 1573<sup>b</sup>  
 Jeconiah . . . . . 1573<sup>b</sup>  
   cf Jehoiachin . . . . . 1577<sup>a</sup> (Genung)  
 Jeconias . . . . . 1573<sup>b</sup>  
 Jedaiah . . . . . 1573<sup>b</sup> (Roberts)  
 Jeddu . . . . . 1573<sup>b</sup>  
   cf Jedaiah . . . . . 1573<sup>b</sup> (Roberts)  
 Jedeus . . . . . 1573<sup>b</sup>  
   cf Aadaiah . . . . . 48<sup>b</sup> (Beecher)  
 Jediael . . . . . 1573<sup>b</sup>  
 Jedidah . . . . . 1573<sup>b</sup>  
 Jedidiah . . . . . 1574<sup>a</sup>  
 Jeduthun  
   cf Asaph . . . . . 262<sup>b</sup> (Millar)  
   cf Psalms, Book of . . . . . 2488<sup>b</sup> (Sampey)  
 Jeeli . . . . . 1574<sup>a</sup>  
 Jeelus . . . . . 1574<sup>a</sup>  
 Jeezer . . . . . 1574<sup>a</sup>  
   cf Abiezer . . . . . 9<sup>a</sup> (Beecher)  
 Jeezerites  
   cf Abiezer . . . . . 9<sup>a</sup> (Beecher)
- Jegar-saha-dutha . . . . . 1574<sup>a</sup>  
 Jehallelel, Jehaleleel . . . . . 1574<sup>a</sup>  
 Jehdeiah . . . . . 1574<sup>a</sup>  
 Jehezkel, Jehezekel . . . . . 1574<sup>a</sup>  
   cf Ezekiel . . . . . 1071<sup>a</sup> (Möller)  
 Jehiah . . . . . 1574<sup>a</sup>  
 Jehiel . . . . . 1574<sup>a</sup> (Roberts)  
   cf Hiereel . . . . . 1389<sup>b</sup>  
   cf Jehuel . . . . . 1586<sup>b</sup>  
   cf Jeiel . . . . . 1586<sup>b</sup> (Roberts)  
 Jehizkiah . . . . . 1574<sup>b</sup>  
 Jehoaddah, Jehoadah . . . . . 1574<sup>b</sup>  
   cf Jarah . . . . . 1569<sup>b</sup>  
 Jehoaddan . . . . . 1574<sup>b</sup>  
 Jehoaddin  
   cf Jehoaddan . . . . . 1574<sup>b</sup>  
 Jehoahaz (of Israel) . . . . . 1574<sup>b</sup> (Caldecott)  
   Chronology of . . . . . 1574<sup>b</sup>  
   Idolatry of . . . . . 1575<sup>a</sup>  
   cf Jehoash (of Judah) . . . . . 1575<sup>b</sup> (Caldecott)  
   cf Joahaz . . . . . 1678<sup>b</sup>  
   Low state of the king-  
   dom . . . . . 1574<sup>b</sup>  
 Jehoahaz (of Judah) . . . . . 1575<sup>a</sup> (Genung)  
   cf Josiah . . . . . 1751<sup>b</sup> (Genung)  
   cf Shallum . . . . . 2747<sup>a</sup> (Umbach)  
 Jehoash (of Israel) . . . . . 1576<sup>b</sup> (Caldecott)  
   Assyria and Damascus . . . . . 1576<sup>b</sup>  
   And Elisha . . . . . 1576<sup>b</sup>  
   cf Jehoahaz (of Israel) . . . . . 1574<sup>b</sup> (Caldecott)  
   cf Jeroboam II . . . . . 1594<sup>a</sup> (Caldecott)  
   Victory over Amaziah . . . . . 1577<sup>a</sup>  
 Jehoash (of Judah) . . . . . 1575<sup>b</sup> (Caldecott)  
   Assassinated . . . . . 1576<sup>b</sup>  
   cf Athaliah . . . . . 317<sup>b</sup> (Caldecott)  
   Decline of . . . . . 1576<sup>a</sup>  
   Made king by Jehoiaada . . . . . 1575<sup>b</sup>  
   Repair of temple . . . . . 1576<sup>a</sup>  
   Saved from his grand-  
   mother . . . . . 1575<sup>b</sup>  
 Jehohanan . . . . . 1577<sup>a</sup> (Roberts)  
   cf Johanan . . . . . 1695<sup>b</sup> (Roberts)  
 Jehoiachin . . . . . 1577<sup>b</sup> (Genung)  
   Deportation by Nebu-  
   chadnezzar . . . . . 1577<sup>b</sup>  
   Imprisonment in Baby-  
   lon . . . . . 1577<sup>b</sup>  
   cf Manasseh . . . . . 1978<sup>a</sup> (Genung)  
   Release of . . . . . 1577<sup>b</sup>  
   Siege and surrender of  
   Jerusalem under . . . . . 573<sup>a</sup> (Nicol)  
   cf Zedekiah . . . . . 3141<sup>a</sup> (Genung)  
 Jehoiaada . . . . . 1578<sup>a</sup> (Roberts)  
   cf Jehoash (of Judah) . . . . . 1575<sup>b</sup> (Caldecott)  
   cf Joiada . . . . . 1727<sup>a</sup>  
   Restoration of temple . . . . . 1578<sup>b</sup>  
   Two accounts of revo-  
   lution . . . . . 1578<sup>a</sup>  
 Jehoiaada (of David's  
   time) . . . . . 1578<sup>a</sup>  
 Jehoiakim . . . . . 1579<sup>a</sup> (Genung)  
   Character . . . . . 1579<sup>b</sup>

Jehoiakim—*continued*

- Character of the period . . . . . 1579<sup>a</sup>  
 Disastrous close of reign . . . . . 1580<sup>a</sup>  
 cf Jeremiah . . . . . 1588<sup>a</sup> (Orelli)  
 cf Joiakim . . . . . 1727<sup>a</sup>  
 cf Jokim . . . . . 1727<sup>a</sup>  
 cf Josiah . . . . . 1751<sup>b</sup> (Genung)  
 Meaning of name . . . . . 1579<sup>a</sup>  
 Prophetic references to . . . . . 1579<sup>a</sup>  
 Relation to Jeremiah . . . . . 1579<sup>b</sup>  
 Revolt and punishment of . . . . . 572<sup>b</sup> (Nicol)  
 Sources for his life . . . . . 1579<sup>a</sup>
- Jehoiarib . . . . . 1580<sup>a</sup>  
 cf Joiarib . . . . . 1727<sup>a</sup>
- Jehonadab (Jonadab) . . . . . 1580<sup>a</sup> (Roberts)  
 cf Jonathan . . . . . 1730<sup>b</sup> (Roberts)  
 cf Rechab, Rechabites . . . . . 253<sup>b</sup> (Mack)
- Jehonathan . . . . . 1580<sup>b</sup>  
 cf Jonathan . . . . . 1730<sup>a</sup> (Roberts)
- Jehoram (of Israel) . . . . . 1580<sup>b</sup> (Mosiman)  
 And Ahaziah of Judah . . . . . 1581<sup>a</sup>  
 Chronology of his reign . . . . . 1580<sup>b</sup>  
 Conflicts with Syria . . . . . 1581<sup>a</sup>  
 cf Jehu . . . . . 1584<sup>b</sup> (Caldecott)  
 cf Joram . . . . . 1732<sup>b</sup>  
 Murdered by Jehu . . . . . 1581<sup>a</sup>  
 Relation to Baalism . . . . . 1580<sup>b</sup>  
 War with Moab . . . . . 1580<sup>b</sup>
- Jehoram (of Judah) . . . . . 1581<sup>b</sup> (Mosiman)  
 Cruel character . . . . . 1581<sup>b</sup>  
 Disease and death . . . . . 1581<sup>b</sup>  
 Encouragement of Baalism . . . . . 1581<sup>b</sup>  
 Letter of Elijah to . . . . . 1581<sup>b</sup>  
 Loss of territory . . . . . 1581<sup>b</sup>  
 Married to Athaliah . . . . . 1581<sup>a</sup>  
 Revolt of Edom . . . . . 1581<sup>b</sup>
- Jehoshabeath . . . . . 1581<sup>b</sup>  
 cf Jehosheba . . . . . 1583<sup>b</sup>
- Jehoshaphat (general) . . . . . 1581<sup>b</sup> (Roberts)
- Jehoshaphat (of Judah) . . . . . 1582<sup>a</sup> (Mosiman)  
 cf Ahaziah . . . . . 83<sup>a</sup> (Mosiman)  
 Alliance with Jehoram . . . . . 1582<sup>b</sup>  
 Death and burial . . . . . 1583<sup>a</sup>  
 Destruction of ships . . . . . 1583<sup>a</sup>  
 Educational system . . . . . 1582<sup>a</sup>  
 Foreign policy . . . . . 1582<sup>b</sup>  
 cf Israel, History of the People . . . . . 1521<sup>b</sup> (Orelli)  
 cf Josaphat . . . . . 1736<sup>b</sup>  
 cf Joshaphat . . . . . 1743<sup>a</sup>  
 Judicial organization . . . . . 1582<sup>a</sup>  
 Public defense . . . . . 1582<sup>b</sup>  
 Reforms of . . . . . 1582<sup>a</sup>  
 Relations with Ahab . . . . . 1582<sup>b</sup>  
 Sources for . . . . . 1582<sup>a</sup>  
 Victory over Moab and Ammon . . . . . 1582<sup>b</sup>
- Jehoshaphat, Valley of . . . . . 1583<sup>a</sup> (Masterman)  
 cf Berecah . . . . . 439<sup>a</sup> (Masterman)  
 cf Gehenna . . . . . 1183<sup>a</sup> (Vos)  
 cf Jerusalem . . . . . 1599<sup>a</sup> (Masterman)  
 cf Kidron, The Brook . . . . . 1798<sup>a</sup> (Masterman)  
 cf King's Vale . . . . . 1808<sup>a</sup> (Masterman)
- Jehosheba . . . . . 1583<sup>b</sup>  
 cf Jehoshabeath . . . . . 1581<sup>b</sup>
- Jehoshua . . . . . 1583<sup>b</sup>  
 cf Joshua . . . . . 1743<sup>a</sup> (Roberts)
- Jehovah  
 cf God, Names of . . . . . 1266<sup>a</sup> (Mack)  
 cf Keys, Power of . . . . . 1796<sup>a</sup> (Carver)  
 cf Lord, The . . . . . 1919<sup>a</sup> (Carver)  
 cf Name . . . . . 2112<sup>a</sup> (W. L. Walker)
- Jehovah-jireh . . . . . 1583<sup>b</sup> (Ewing)  
 Jehovah-nissi . . . . . 1584<sup>a</sup>
- Jehovah, Servant of . . . . . 2739<sup>a</sup> (Hough)
- Jehovah-shalom . . . . . 1584<sup>a</sup>  
 Jehovah-shammah . . . . . 1584<sup>a</sup>  
 Jehovah-tsidkenu . . . . . 1584<sup>a</sup>  
 Jehozabad . . . . . 1584<sup>a</sup>  
 Jehozadak . . . . . 1584<sup>b</sup>  
 cf Josedech . . . . . 1736<sup>b</sup>
- Jehu . . . . . 1584<sup>b</sup> (Caldecott)  
 Anointed king . . . . . 1585<sup>a</sup>  
 Challenge to Samaria . . . . . 1585<sup>b</sup>  
 Character of . . . . . 1586<sup>a</sup>  
 Destruction of house of Ahab . . . . . 1585<sup>b</sup>  
 Hosea's verdict on . . . . . 1585<sup>a</sup>  
 cf Israel, History of . . . . . 1521<sup>b</sup> (Orelli)  
 cf Jezebel . . . . . 1675<sup>b</sup> (Roberts)  
 Massacre of Baalites . . . . . 1585<sup>b</sup>  
 cf Menahem . . . . . 2031<sup>b</sup> (Caldecott)  
 Misfortunes of . . . . . 1586<sup>a</sup>  
 Murder of Jezebel . . . . . 1585<sup>a</sup>  
 Murder of Judaeans  
 princes . . . . . 1585<sup>b</sup>  
 Murder of the kings . . . . . 1585<sup>a</sup>  
 Officer of Ahab . . . . . 1584<sup>b</sup>  
 Officer of Jehoram . . . . . 1584<sup>b</sup>  
 Relations with Jona-  
 dab ben Rechab . . . . . 1585<sup>b</sup>  
 Ride to Jezreel . . . . . 1585<sup>a</sup>  
 Tribute to Shalmaneser II . . . . . 1586<sup>a</sup>  
 Wars with Hazael . . . . . 1585<sup>b</sup>
- Jehubbah . . . . . 1586<sup>a</sup>  
 Jehucal . . . . . 1586<sup>a</sup>  
 Jehud . . . . . 1586<sup>a</sup>  
 Jehudi . . . . . 1586<sup>a</sup>
- Jehudijah  
 cf Ha-jehudijah . . . . . 1321<sup>b</sup>
- Jehuel . . . . . 1586<sup>b</sup>  
 cf Jehiel . . . . . 1574<sup>a</sup> (Roberts)
- Jehush  
 cf Jeush . . . . . 1675<sup>a</sup>
- Jeiel . . . . . 1586<sup>b</sup> (Roberts)  
 cf Jehiel . . . . . 1574<sup>a</sup> (Roberts)  
 cf Jeuel . . . . . 1675<sup>a</sup>  
 cf Oehielus . . . . . 2178<sup>a</sup>



- Jekabzeel  
 cf Kabzeel . . . . . 1788<sup>a</sup>
- Jekameam . . . . . 1586<sup>b</sup>
- Jekamiah . . . . . 1586<sup>b</sup>
- Jekuthiel . . . . . 1586<sup>b</sup>
- Jemimah . . . . . 1586<sup>b</sup>
- Jemnaan . . . . . 1586<sup>b</sup>
- Jemuel . . . . . 1586<sup>b</sup>
- Jeopard, Jeopardy . . . . . 1586<sup>b</sup>
- Jephthah . . . . . 1587<sup>a</sup> (Schenk)  
 cf Judges, Book of . . . 1772<sup>a</sup> (Geden)  
 cf Vow . . . . . 3058<sup>a</sup> (Levertoff)
- Jephunneh . . . . . 1587<sup>a</sup>
- Jerah . . . . . 1587<sup>a</sup>
- Jerahmeel . . . . . 1587<sup>b</sup> (Roberts)
- Jerechu, Jerechus  
 cf Jericho . . . . . 1592<sup>a</sup> (Wright)
- Jered . . . . . 1587<sup>b</sup>  
 cf Jared . . . . . 1570<sup>a</sup>
- Jeremai . . . . . 1587<sup>b</sup>  
 cf Jeremias . . . . . 1591<sup>a</sup>
- Jeremiah (general) . . . . 1587<sup>b</sup> (Roberts)  
 cf Jeremias . . . . . 1591<sup>a</sup>
- Jeremiah (prophet) . . . . 1588<sup>a</sup> (Orelli); 407<sup>a</sup> (T. W. Davies)
- Compelled to go to  
 Egypt . . . . . 1588<sup>b</sup>
- Conspiracy against . . . 1588<sup>a</sup>
- Depressing message of 1589<sup>b</sup>
- Disposition . . . . . 1589<sup>a</sup>
- cf Egyptian Disper-  
 sion . . . . . 856<sup>a</sup> (Nicol)
- Growth of prophecies 1590<sup>a</sup>
- Idealism of . . . . . 1590<sup>a</sup>
- of Israel, History of . . 1524<sup>a</sup> (Orelli)
- of Lamentations . . . . 1824<sup>b</sup> (Orelli)
- Length of ministry . . . 1588<sup>a</sup>
- of Ministry in Jerusa-  
 lem . . . . . 573<sup>a</sup> (Nicol)
- Ministry in reign of  
 Josiah . . . . . 1588<sup>a</sup>
- Name and parentage . . 1588<sup>a</sup>
- of Pharaoh Hophra . . . 2359<sup>b</sup> (Nicol)
- Poetic nature of . . . . 1590<sup>a</sup>
- Preaching of . . . . . 1589<sup>b</sup>
- Preaching and death  
 in Egypt . . . . . 1588<sup>b</sup>
- Preparation of the roll 1588<sup>b</sup>
- In prison . . . . . 1588<sup>b</sup>
- References to Baby-  
 lonians by . . . . . 1589<sup>b</sup>
- References to Scythians  
 by . . . . . 1589<sup>b</sup>
- In reign of Jehoiachin 1588<sup>b</sup>
- In reign of Jehoiakim 1588<sup>a</sup>
- In reign of Zedekiah . . 1588<sup>b</sup>
- With the remnant after  
 fall of Jerusalem . . . 1588<sup>b</sup>
- cf Sacrifice, OT . . . . . 2648<sup>a</sup> (Reeve)
- cf Sheshach . . . . . 2765<sup>b</sup> (Wolf)
- Siege of Jerusalem . . . 1588<sup>b</sup>
- Jeremiah (prophet)—*continued*  
 Testimony of book to  
 character of . . . . . 1589<sup>a</sup>
- Tradition of stoning . . 1589<sup>a</sup>
- As a type of Jesus . . . 1589<sup>a</sup>
- Jeremiah, Book of  
 Authenticity . . . . . 1590<sup>b</sup>
- Composition . . . . . 1590<sup>a</sup>
- Editorial elements . . . 1590<sup>b</sup>
- Integrity . . . . . 1590<sup>b</sup>
- cf Obadiah, Book of . . . 2173<sup>b</sup> (Sampey)
- cf Palestine . . . . . 2219<sup>b</sup> (Conder)
- Relation to LXX . . . . 1591<sup>a</sup>
- Jeremiah, Epistle of  
 cf Jeremy, Epistle of . . 1591<sup>a</sup> (T. W. Davies)
- Jeremiah, The Lamenta-  
 tions of  
 cf Lamentations . . . . 1824<sup>a</sup> (Orelli)
- Jeremias . . . . . 1591<sup>b</sup>  
 cf Jeremai . . . . . 1587<sup>b</sup>  
 cf Jeremiah . . . . . 1587<sup>b</sup> (Roberts)
- Jeremiel . . . . . 1591<sup>a</sup>  
 cf Uriel . . . . . 3040<sup>a</sup> (Angus)
- Jeremoth . . . . . 1591<sup>a</sup>  
 cf Hieremoth (Apoc) . . 1389<sup>b</sup>  
 cf Ramoth . . . . . 2529<sup>a</sup>
- Jeremy  
 cf Jeremiah (general) 1587<sup>b</sup> (Roberts)
- Jeremy, The Epistle of . . 1591<sup>a</sup> (T. W. Davies)
- Authorship, date, and  
 aim . . . . . 1591<sup>b</sup>
- Canonicity and posi-  
 tion . . . . . 1591<sup>b</sup>
- Contents . . . . . 1591<sup>b</sup>
- Greek original . . . . . 1591<sup>b</sup>
- Nature of . . . . . 1591<sup>b</sup>
- Text and Versions . . . 1592<sup>a</sup>
- Jeriah . . . . . 1592<sup>a</sup>
- Jeribai . . . . . 1592<sup>a</sup>
- Jericho . . . . . 1592<sup>a</sup> (Wright)  
 Aqueducts near . . . . 1592<sup>b</sup>
- Explanation of fall . . 1592<sup>a</sup>
- of Jordan Valley . . . . 1735<sup>a</sup> (Wright)
- of Joshua . . . . . 1745<sup>b</sup> (Roberts)
- of Judah, Territory of 1763<sup>a</sup> (Masterman)
- Later OT references . . 1592<sup>b</sup>
- Location . . . . . 1592<sup>a</sup>
- In NT times . . . . . 1592<sup>b</sup>
- cf Palestine, Recent  
 Exploration . . . . . 2229<sup>b</sup> (Cobern)
- As rendezvous for pil-  
 grims . . . . . 1592<sup>b</sup>
- Jeriel . . . . . 1592<sup>b</sup>
- Jerijah  
 cf Jeriah . . . . . 1592<sup>a</sup>
- Jerimoth . . . . . 1593<sup>a</sup> (Roberts)
- Jerioth . . . . . 1593<sup>a</sup>
- Jeroboam I . . . . . 1593<sup>a</sup> (Mosiman)  
 Choice of capital . . . . 1593<sup>b</sup>
- Chosen king . . . . . 1593<sup>b</sup>
- Convocation at She-  
 chem . . . . . 1593<sup>b</sup>

Jeroboam I—*continued*

- Ephraimite leader. . . . . 1593<sup>a</sup>  
 of Israel, History of the  
 People . . . . . 1520<sup>b</sup> (Orelli)  
 of Nebat . . . . . 2126<sup>b</sup>  
 of Rehoboam . . . . . 2551<sup>a</sup> (Mosiman)  
 Relations with Ahijah 1593<sup>b</sup>  
 Relations with the  
 prophets . . . . . 1594<sup>a</sup>  
 Religious policy . . . . . 1594<sup>a</sup>  
 cf Shishak . . . . . 2777<sup>b</sup> (Nicol)  
 Sources for . . . . . 1593<sup>a</sup>
- Jeroboam II. . . . . 1594<sup>a</sup> (Caldecott)  
 Ceremonial religion . . . . . 1594<sup>b</sup>  
 cf Jehoash (of Israel) 1576<sup>b</sup> (Caldecott)  
 Ministry of Jonah . . . . . 1595<sup>a</sup>  
 Mission of Amos . . . . . 1595<sup>a</sup>  
 cf Shallum . . . . . 2747<sup>a</sup> (Caldecott)  
 Success of . . . . . 1594<sup>b</sup>  
 Testimony of Amos . . . . . 1594<sup>b</sup>
- Jeroham . . . . . 1595<sup>a</sup> (Roberts)
- Jerome  
 cf Mark, Gospel of . . . . . 1990<sup>a</sup> (Farmer)  
 cf Septuagint . . . . . 2723<sup>b</sup> (Thackeray)
- Jerubbaal . . . . . 1595<sup>a</sup>  
 cf Gideon . . . . . 1226<sup>b</sup> (Schenk)  
 cf Jerubbesheth . . . . . 1595<sup>a</sup> (Roberts)
- Jerubbesheth . . . . . 1595<sup>a</sup> (Roberts)  
 cf Jerubbaal . . . . . 1595<sup>a</sup>  
 cf Jeshebeab . . . . . 1622<sup>a</sup>
- Jeruel . . . . . 1595<sup>b</sup>  
 cf Jezreel . . . . . 1677<sup>a</sup> (Ewing)
- Jerusalem . . . . . 1595<sup>a</sup> (Masterman)  
 Ancient water supply 1603<sup>a</sup>  
 cf Bethesda . . . . . 444<sup>b</sup> (Masterman)  
 Birket Hâmmam el  
 Baṭrack . . . . . 1610<sup>a</sup>  
 Birket Israël . . . . . 1610<sup>a</sup>  
 Birket Mamilla . . . . . 1610<sup>b</sup>  
 Birket es Sultan . . . . . 1610<sup>b</sup>  
 Canaanite aqueduct 1608<sup>b</sup>  
 Cistern structure . . . . . 1609<sup>b</sup>  
 Cisterns of temple  
 area . . . . . 1610<sup>a</sup>  
 Cuttings at Job's  
 Well . . . . . 1609<sup>b</sup>  
 cf Fuller's Field . . . . . 1148<sup>a</sup> (Masterman)  
 cf Gezer . . . . . 1222<sup>a</sup> (Masterman)  
 cf Gihon . . . . . 1228<sup>b</sup> (Masterman)  
 Gihon dam . . . . . 1608<sup>b</sup>  
 Hezekiah's aque-  
 duct . . . . . 1609<sup>b</sup>  
 High level aqueduct. 1611<sup>b</sup>  
 Low level aqueduct. 1611<sup>a</sup>  
 Other aqueducts . . . . . 1609<sup>b</sup>  
 Pool of Bethesda . . . . . 1610<sup>a</sup>  
 Pool of Siloam . . . . . 1610<sup>b</sup>  
 cf Siloam . . . . . 2791<sup>a</sup> (Masterman)  
 Present supply . . . . . 1611<sup>b</sup>  
 Solomon's Pools . . . . . 1611<sup>a</sup>  
 Twin pools . . . . . 1610<sup>a</sup>

Jerusalem—*continued*

- Climate  
 Cisterns . . . . . 1597<sup>a</sup>  
 Cold and heat . . . . . 1597<sup>b</sup>  
 Healthfulness . . . . . 1597<sup>a</sup>  
 Rainfall . . . . . 1597<sup>b</sup>
- cf Destruction of (586  
 BC) . . . . . 573<sup>b</sup> (Nicol)
- Excavations . . . . . 1601<sup>b</sup>  
 Archaeological so-  
 cieties . . . . . 1602<sup>b</sup>  
 Bliss and Dickie . . . . . 1602<sup>a</sup>  
 Clermont-Ganneau . . . . . 1602<sup>a</sup>  
 Maudslay . . . . . 1602<sup>a</sup>  
 Merrill, work of . . . . . 1602<sup>a</sup>  
 Palestine Explora-  
 tion Fund . . . . . 1602<sup>a</sup>  
 Parker, work of . . . . . 1602<sup>a</sup>  
 Robinson, work of . . . . . 1602<sup>a</sup>  
 Schick, work of . . . . . 1602<sup>a</sup>  
 Warren and Conder. 1602<sup>a</sup>  
 Wilson, work of . . . . . 1602<sup>a</sup>
- Fortification . . . . . 1602<sup>b</sup>  
 cf Fortification . . . . . 1136<sup>b</sup> (Nicol)
- Gates . . . . . 1603<sup>a</sup>  
 Benjamin, Gate of . . . . . 1607<sup>b</sup>  
 Dung Gate . . . . . 1606<sup>b</sup>  
 Ephraim, Gate of . . . . . 1607<sup>b</sup>  
 Existing gates . . . . . 1603<sup>a</sup>  
 Fish Gate . . . . . 1607<sup>a</sup>  
 Fountain Gate . . . . . 1606<sup>b</sup>  
 cf Hammeah, Tower  
 of . . . . . 1325<sup>b</sup> (Masterman)  
 cf Hammiphkad,  
 Gate of . . . . . 1325<sup>b</sup>  
 cf Hananel, Tower of 1333<sup>a</sup> (Masterman)  
 Horse Gate . . . . . 1607<sup>a</sup>  
 cf King's Garden . . . . . 1808<sup>a</sup> (Masterman)  
 cf King's Pool . . . . . 1808<sup>a</sup>  
 cf Maktesh . . . . . 1969<sup>a</sup> (Masterman)  
 cf Miphkad, Gate of 2062<sup>b</sup>  
 cf Mishneh . . . . . 2066<sup>b</sup> (Masterman)  
 Names, various . . . . . 1603<sup>a</sup>  
 Old Gate . . . . . 1607<sup>a</sup>  
 Sheep Gate . . . . . 1607<sup>a</sup>  
 cf Sheep Gate . . . . . 2758<sup>a</sup>  
 cf Sur . . . . . 2871<sup>b</sup>  
 Upper Gate of  
 temple . . . . . 1608<sup>a</sup>  
 Valley Gate . . . . . 1606<sup>b</sup>  
 cf Valley Gate . . . . . 3045<sup>b</sup> (Masterman)  
 Water Gate . . . . . 1607<sup>a</sup>
- Geology . . . . . 1596<sup>b</sup>  
 cf Geology of Pales-  
 tine . . . . . 1215<sup>b</sup> (Day)  
 Limestone . . . . . 1597<sup>a</sup>
- Hills . . . . . 1599<sup>b</sup>  
 cf Gerizim, Mount . . . . . 1218<sup>a</sup> (Ewing)  
 cf Millo . . . . . 2055<sup>a</sup> (Masterman)  
 cf Olives, Mount of . . . . . 2186<sup>a</sup> (Masterman)  
 cf Ophel . . . . . 2196<sup>b</sup> (Masterman)  
 Zion, fortress of . . . . . 1597<sup>b</sup>

Jerusalem—*continued*

- History . . . . . 1613<sup>b</sup>
  - of Adoni-zedek . . . . . 58<sup>a</sup> (Mack)
- Akra . . . . . 1613<sup>b</sup>
- Alexander the Great 1616<sup>b</sup>
- Antiochian rule . . . . . 1617<sup>a</sup>
- Antiochus, capture
  - by . . . . . 1617<sup>b</sup>
- Antiochus, cruelties
  - of . . . . . 1617<sup>b</sup>
- Antiochus Epiph-
  - anes . . . . . 1617<sup>a</sup>
- Antipater made pro-
  - curator . . . . . 1618<sup>b</sup>
- Bar-cochba's revolt 1619<sup>b</sup>
- Besieged by Hazael 1615<sup>a</sup>
- cf Beth-zur . . . . . 454<sup>a</sup> (Masterman)
- cf Bezetha . . . . . 459<sup>b</sup>
- Capture by Syrians
  - in 134 BC . . . . . 1618<sup>a</sup>
- Chosroes II captures
  - city . . . . . 1620<sup>a</sup>
- Constantine's church 1620<sup>a</sup>
- Crusades . . . . . 1620<sup>b</sup>
- David's city . . . . . 1614<sup>a</sup>
- Disruption . . . . . 1614<sup>b</sup>
- Earthquake, the . . . . . 1615<sup>b</sup>
- Egyptian domina-
  - tion . . . . . 1617<sup>a</sup>
- Eudoxia's walls . . . . . 1620<sup>a</sup>
- Expansion in Da-
  - vid's day . . . . . 1614<sup>a</sup>
- Fall of the city, 70
  - AD . . . . . 1619<sup>b</sup>
- Hadrian's restora-
  - tions . . . . . 1620<sup>a</sup>
- Hasmonean build-
  - ings . . . . . 1618<sup>a</sup>
- Hebrew conquest . . . . . 1613<sup>b</sup>
- Hellenization of city 1617<sup>a</sup>
- Heracles enters city 1620<sup>a</sup>
- Herod Agrippa I . . . . . 1619<sup>a</sup>
- Herod Archelaus . . . . . 1619<sup>a</sup>
- Herod's buildings . . . . . 1618<sup>b</sup>
- Herod the Great's
  - conquest . . . . . 1618<sup>b</sup>
- Hezekiah's public
  - works . . . . . 1615<sup>b</sup>
- Hezekiah's reforms . . . . . 1615<sup>b</sup>
- Jebusite city . . . . . 1614<sup>a</sup>
- Jehoash, captured by 1615<sup>a</sup>
- Jeremiah's ministry 1616<sup>a</sup>
- Jewish revolt . . . . . 1619<sup>b</sup>
- Jonathan's restora-
  - tions . . . . . 1618<sup>a</sup>
- Josiah's reforms and
  - death . . . . . 1616<sup>a</sup>
- Judas, defeat of . . . . . 1617<sup>b</sup>
- Judas Maccabaeus,
  - death of . . . . . 1618<sup>a</sup>
- Justinian's buildings 1620<sup>a</sup>
  - cf Praetorium . . . . . 2428<sup>b</sup> (Masterman)

Jerusalem—*continued*

- History—*continued*
  - Kharizimians . . . . . 1620<sup>b</sup>
  - Maccabean uprising 1617<sup>b</sup>
  - Manasseh's reign . . . . . 1615<sup>b</sup>
  - of Melchizedek . . . . . 2028<sup>b</sup> (Roberts)
  - Moslem conquest . . . . . 1620<sup>a</sup>
  - Nehemiah's wall . . . . . 1616<sup>b</sup>
  - of Ophel . . . . . 2196<sup>b</sup> (Masterman)
  - Ottoman Turks . . . . . 1620<sup>b</sup>
  - Paleolithic remains . . . . . 1613<sup>b</sup>
  - Parthian conquest . . . . . 1618<sup>b</sup>
  - Persian period . . . . . 1616<sup>b</sup>
  - Pilate, Pontius . . . . . 1619<sup>a</sup>
  - Plundered by Arabs 1615<sup>a</sup>
  - Pompey's conquest
    - of city . . . . . 1618<sup>b</sup>
  - Reign of Ahaz . . . . . 1615<sup>b</sup>
  - Revival of city . . . . . 1616<sup>b</sup>
  - Roman intervention 1618<sup>a</sup>
    - of Salem . . . . . 2663<sup>a</sup> (Pinches)
  - Seljuk Turks . . . . . 1620<sup>b</sup>
  - Shishak's invasion . . . . . 1615<sup>a</sup>
  - Siege and destruction
    - by Nebuchadnezzar . . . . . 1616<sup>b</sup>
  - Siege by Vespasian
    - and Titus . . . . . 1619<sup>b</sup>
  - of Siloam . . . . . 2791<sup>a</sup> (Masterman)
  - Solomon's city . . . . . 1614<sup>b</sup>
  - Solomon's walls . . . . . 1614<sup>b</sup>
    - cf Solomon . . . . . 2824<sup>a</sup> (Weir)
  - Tell el-Amarna let-
    - ters . . . . . 1613<sup>b</sup>
  - Uzziah's fortifica-
    - tions . . . . . 1615<sup>a</sup>
- Literature . . . . . 1621<sup>b</sup>
- Modern city . . . . . 1620<sup>b</sup>
  - Christian popula-
    - tion . . . . . 1620<sup>b</sup>
  - Jewish population . . . . . 1620<sup>b</sup>
  - Official and munic-
    - pal conditions . . . . . 1621<sup>a</sup>
- Name . . . . . 1596<sup>a</sup>
  - In cuneiform . . . . . 1596<sup>a</sup>
  - In Greek and Latin 1596<sup>b</sup>
  - In Hebrew . . . . . 1596<sup>b</sup>
  - Meaning . . . . . 1596<sup>b</sup>
- cf Palestine, Recent
  - Exploration . . . . . 2226<sup>b</sup> (Cobern)
- cf Pentateuch . . . . . 2305<sup>a</sup> (Wiener)
- Site . . . . . 1598<sup>b</sup>
  - Debris accumula-
    - tions . . . . . 1599<sup>b</sup>
  - East Valley . . . . . 1599<sup>a</sup>
  - Eastern hill . . . . . 1600<sup>a</sup>
  - cf Fuller's Field . . . . . 1148<sup>a</sup> (Masterman)
  - cf Goah . . . . . 1248<sup>b</sup>
  - cf Golgotha . . . . . 1275<sup>a</sup> (Masterman)
  - cf Harsith . . . . . 1341<sup>a</sup>
  - cf Mishneh . . . . . 2066<sup>b</sup> (Masterman)
  - Soil . . . . . 1598<sup>b</sup>

Jerusalem—*continued*Site—*continued*

- St. Anne's Valley . . . 1599<sup>b</sup>  
 Surrounding moun-  
 tains . . . . . 1598<sup>b</sup>  
 Temple hill . . . . . 1600<sup>b</sup>  
 cf Temple . . . . . 2930<sup>a</sup>; 2937<sup>a</sup> (Caldecott;  
 Orr)  
 Tyropoeon Valley . . . 1599<sup>b</sup>  
 West Valley . . . . . 1599<sup>a</sup>  
 Western hill . . . . . 1599<sup>b</sup>  
 cf Zion . . . . . 3150<sup>b</sup> (Masterman)

## Springs

- Bath of healing . . . . 1598<sup>b</sup>  
 cf Bethesda . . . . . 444<sup>b</sup> (Masterman)  
 Character of waters 1598<sup>a</sup>  
 cf Gihon . . . . . 1228<sup>b</sup> (Masterman)  
 Intermittent nature 1598<sup>a</sup>  
 Jackal's Well . . . . . 1548<sup>b</sup>; 1548<sup>b</sup> (Masterman)  
 Job's Well . . . . . 1598<sup>a</sup>  
 Outlet . . . . . 1598<sup>a</sup>  
 cf Siloam . . . . . 2791<sup>a</sup> (Masterman)  
 Spring of the Al-  
 mond . . . . . 1598<sup>b</sup>  
 Spring of Gihon . . . . 1597<sup>b</sup>

## Tombs, remains and

- sites . . . . . 1611<sup>b</sup>  
 Absalom's tomb . . . . 1612<sup>a</sup>  
 Church of Holy  
 Sepulchre . . . . . 1613<sup>a</sup>  
 Coenaculum . . . . . 1613<sup>a</sup>  
 Egyptian tomb . . . . . 1612<sup>a</sup>  
 Garden Tomb, the . . . . 1612<sup>a</sup>  
 cf Golgotha . . . . . 1275<sup>a</sup> (Masterman)  
 Great foundation  
 stones . . . . . 1612<sup>b</sup>  
 Grotto of St. James 1612<sup>a</sup>  
 Herod's tombs . . . . . 1612<sup>a</sup>  
 Kings, tombs of . . . . . 1612<sup>a</sup>  
 Robinson's Arch . . . . . 1613<sup>a</sup>  
 cf Sepulchre . . . . . 2732<sup>a</sup>  
 Simon the Just, tomb  
 of . . . . . 1612<sup>b</sup>  
 cf Temple . . . . . 2930<sup>a</sup> (Caldecott; Orr)  
 Various tombs . . . . . 1612<sup>a</sup>  
 Virgin, tomb of . . . . . 1613<sup>b</sup>  
 Zachariah, tomb of . . . . 1612<sup>a</sup>  
 cf Zachariah . . . . . 3129<sup>a</sup>
- Topography . . . . . 1600<sup>a</sup>  
 Akra . . . . . 1601<sup>a</sup>  
 Bezetha . . . . . 1600<sup>b</sup>  
 City of David . . . . . 1601<sup>b</sup>  
 Five hills, the . . . . . 1600<sup>b</sup>  
 Josephus' descrip-  
 tion . . . . . 1600<sup>a</sup>  
 Lower city . . . . . 1601<sup>b</sup>  
 Northern quarter . . . . . 1600<sup>b</sup>  
 Upper and lower  
 city . . . . . 1600<sup>a</sup>  
 Zion . . . . . 1601<sup>b</sup>
- Towers  
 Furnaces, Tower of . . . . 1607<sup>b</sup>

Jerusalem—*continued*

- cf Uz . . . . . 3042<sup>b</sup> (Weir)  
 Valleys  
 cf Hinnom, Valley of 1393<sup>b</sup> (Masterman)  
 cf Jehoshaphat, Val-  
 ley of . . . . . 1583<sup>a</sup> (Masterman)  
 cf Kidron, The Brook 1798<sup>a</sup> (Masterman)  
 cf Vale, Valley . . . . . 3045<sup>a</sup> (Day)  
 Walls . . . . . 1602<sup>b</sup>  
 Broad wall . . . . . 1607<sup>b</sup>  
 Buried remains . . . . . 1603<sup>b</sup>  
 Dam of the Tyro-  
 poeon . . . . . 1604<sup>a</sup>  
 First wall . . . . . 1604<sup>b</sup>  
 Josephus' testimony . . . . 1604<sup>b</sup>  
 cf Millo . . . . . 2055<sup>a</sup> (Masterman)  
 Nehemiah's account . . . . 1606<sup>b</sup>  
 Present walls . . . . . 1602<sup>b</sup>  
 Robinson's theory . . . . . 1605<sup>b</sup>  
 Second wall . . . . . 1605<sup>a</sup>  
 Date . . . . . 1606<sup>a</sup>  
 South wall . . . . . 1602<sup>b</sup>  
 Third wall . . . . . 1605<sup>b</sup>
- Jerusalem, New . . . . . 1621<sup>b</sup> (Vos)  
 cf Revelation of John . . . . 2582<sup>b</sup> (Orr)
- Jerusha . . . . . 1622<sup>a</sup>  
 Jesarelah . . . . . 1622<sup>a</sup>  
 Jeshaiiah . . . . . 1622<sup>a</sup> (Roberts)  
 cf Osaias . . . . . 2202<sup>a</sup>  
 Jeshanah . . . . . 1622<sup>a</sup>  
 Jesharelah . . . . . 1622<sup>a</sup>  
 Jeshebeab . . . . . 1622<sup>a</sup>  
 cf Jerubbesheth . . . . . 1595<sup>a</sup> (Roberts)  
 Jeshar . . . . . 1622<sup>a</sup>  
 Jeshimon . . . . . 1622<sup>a</sup> (Masterman)  
 cf Judaea . . . . . 1757<sup>a</sup> (Masterman)  
 cf Judah, Territory of . . . . 1763<sup>a</sup> (Masterman)
- Jeshishai . . . . . 1622<sup>b</sup>  
 Jeshohaiah . . . . . 1622<sup>b</sup>  
 Jeshua (person) . . . . . 1622<sup>b</sup> (Roberts)  
 cf Jesus Christ . . . . . 1624<sup>a</sup> (Orr)  
 cf Joshua (general) . . . . . 1743<sup>a</sup>  
 Jeshua (place) . . . . . 1622<sup>b</sup>  
 Jeshuah . . . . . 1622<sup>b</sup>  
 Jeshurun . . . . . 1623<sup>a</sup> (Roberts)  
 cf Jashar, Book of . . . . . 1570<sup>a</sup> (Orr)
- Jesiah  
 cf Isshiah . . . . . 1542<sup>b</sup>
- Jesias . . . . . 1623<sup>a</sup>  
 cf Josias . . . . . 1753<sup>b</sup>
- Jesimiel . . . . . 1623<sup>a</sup>  
 Jesse . . . . . 1623<sup>a</sup> (Roberts)  
 cf Abigail . . . . . 9<sup>b</sup> (Mack)  
 cf Abishai . . . . . 13<sup>a</sup> (Mack)  
 cf Boaz . . . . . 491<sup>a</sup> (Roberts)  
 cf Nahash . . . . . 2109<sup>a</sup> (W. W. Davies)  
 cf Root of Jesse . . . . . 2623<sup>b</sup>  
 cf Samuel, Books of . . . . . 2678<sup>b</sup> (Geden)
- Jesting . . . . . 1624<sup>a</sup>  
 Jesui  
 cf Ishvah . . . . . 1511<sup>a</sup>

- Jesuites  
 cf Ishvi . . . . . 1511<sup>a</sup>
- Jesurun  
 cf Jeshurun . . . . . 1623<sup>a</sup> (Roberts)
- Jesus (general) . . . . . 1624<sup>a</sup>  
 cf Jeshua . . . . . 1622<sup>b</sup> (Roberts)
- Jesus Christ . . . . . 1624<sup>a</sup> (Orr)  
 Chronology . . . . . 1628<sup>b</sup>  
 of Chronology of NT 644<sup>b</sup> (Armstrong)  
 Date of baptism . . . . . 1628<sup>b</sup>  
 Date of birth . . . . . 1628<sup>b</sup>  
 Date of crucifixion . . . . . 1629<sup>a</sup>  
 Length of ministry . . . . . 1629<sup>a</sup>  
 of Luke, Gospel of . . . . . 1940<sup>a</sup> (A. T. Robertson)
- Life . . . . . 1631<sup>a</sup>  
 Adoration of Jesus . . . . . 61<sup>a</sup> (Edwards)  
 Agony in garden . . . . . 1659<sup>b</sup>  
 Angels' song . . . . . 1633<sup>a</sup>  
 Annunciation, the . . . . . 1631<sup>b</sup>  
 Anointing at Bethany . . . . . 1655<sup>a</sup>  
 Anointing at Simon's house . . . . . 1644<sup>a</sup>  
 Appearances of Jesus after resurrection . . . . . 1665<sup>b</sup>  
 Arrest . . . . . 1660<sup>a</sup>; 1668<sup>b</sup> (Maclaren)  
 Ascension . . . . . 1666<sup>b</sup>; 615<sup>a</sup> (Bevan)  
 Atonement . . . . . 627<sup>b</sup> (Orr)  
 Baptism of Jesus . . . . . 1635<sup>a</sup>  
 Barabbas v. Jesus . . . . . 1662<sup>a</sup>  
 Barren fig tree . . . . . 1655<sup>b</sup>  
 Bartimaeus healed . . . . . 1654<sup>b</sup>  
 Beatitudes . . . . . 1643<sup>a</sup>  
 Beelzebub . . . . . 1644<sup>b</sup>  
 Bethany beyond Jordan . . . . . 1652<sup>b</sup>  
 At Bethsaida . . . . . 451<sup>b</sup> (Ewing)  
 Betrayal by Judas . . . . . 1657<sup>b</sup>; 454<sup>b</sup> (Rees)  
 of Judas Iscariot . . . . . 1766<sup>a</sup> (Kerr)  
 Birth in Bethlehem . . . . . 1632<sup>b</sup>; 1470<sup>b</sup>  
 of Chronology of NT . . . . . 645<sup>a</sup> (Armstrong)  
 Birth and infancy . . . . . 1471<sup>b</sup> (Sweet)  
 Blind from birth healed . . . . . 1650<sup>b</sup>  
 Boyhood growth . . . . . 1634<sup>a</sup>  
 Brazen serpent . . . . . 1638<sup>a</sup>  
 Bread of Life . . . . . 1647<sup>a</sup>  
 Brethren of Jesus . . . . . 518<sup>b</sup> (Jacobs)  
 Burial . . . . . 1664<sup>a</sup>  
 Preparations for . . . . . 529<sup>b</sup> (Eager)  
 At Caesarea Philippi 1795<sup>a</sup> (Carver)  
 Call of four disciples 1639<sup>a</sup>  
 Capernaum synagogue . . . . . 1639<sup>b</sup>  
 Centurion's servant . . . . . 1643<sup>b</sup>  
 Ceremonial washings 1647<sup>b</sup>  
 Child as example of humility . . . . . 1650<sup>a</sup>  
 Children blessed . . . . . 1654<sup>a</sup>  
 Chronology of final week . . . . . 1655<sup>a</sup>
- Jesus Christ—*continued*  
 Life—*continued*  
 Chronology of last meal with disciples . . . . . 1658<sup>a</sup>  
 Chronology of last period in Galilee 1651<sup>a</sup>  
 Circumcision . . . . . 1633<sup>a</sup>  
 Claims of Jesus . . . . . 1641<sup>b</sup>  
 Cleansing of temple 1637<sup>a</sup>; 1650<sup>b</sup>  
 Cross-bearing . . . . . 1649<sup>a</sup>  
 Cross, scenes at . . . . . 1663<sup>a</sup>  
 Crucifixion, the . . . . . 1662<sup>b</sup>  
 of Blood and Water . . . . . 489<sup>a</sup> (Luering)  
 Darkness at death . . . . . 1663<sup>b</sup>  
 Daughter of Jairus raised . . . . . 1646<sup>a</sup>  
 David's son and lord . . . . . 1656<sup>b</sup>  
 Deaf man healed . . . . . 1648<sup>a</sup>  
 Death of Jesus . . . . . 1663<sup>b</sup>  
 Decapolis retreat . . . . . 1648<sup>a</sup>  
 Demand for authority . . . . . 1656<sup>a</sup>  
 Demon possession a reality . . . . . 1640<sup>a</sup>  
 of Demoniac Possession . . . . . 827<sup>b</sup> (Sweet)  
 Demoniac in synagogue . . . . . 1639<sup>b</sup>  
 Denunciation of scribes and Pharisees . . . . . 1656<sup>a</sup>  
 Denunciation of unbelief . . . . . 1644<sup>a</sup>  
 Discourse on Last Things . . . . . 1657<sup>a</sup>  
 Discourse in upper room . . . . . 1659<sup>a</sup>  
 Dispute about greatness . . . . . 1649<sup>b</sup>  
 Dispute about precedence . . . . . 1658<sup>a</sup>  
 Divine sonship . . . . . 1641<sup>b</sup>  
 Divisions . . . . . 1631<sup>a</sup>  
 Divorce, teaching on 1653<sup>b</sup>  
 Early disciples . . . . . 1636<sup>b</sup>  
 Early preaching . . . . . 1638<sup>a</sup>  
 "Ecce homo" . . . . . 1662<sup>a</sup>  
 Egypt and Nazareth . . . . . 1633<sup>b</sup>  
 Elisabeth visited . . . . . 1632<sup>a</sup>  
 Entry into Jerusalem . . . . . 1655<sup>b</sup>  
 Epileptic child cured 1649<sup>a</sup>  
 Evil, relation to . . . . . 1643<sup>b</sup>  
 Exaltation of Jesus 614<sup>b</sup> (Bevan)  
 Expectations of the pious . . . . . 1631<sup>a</sup>  
 Fasting and joy . . . . . 1641<sup>a</sup>  
 Feast of Dedication 1652<sup>b</sup>

Jesus Christ—*continued*Life—*continued*

- Feast of John 5. . . . .1641<sup>a</sup>  
 Feast of Tabernacles. . . . .1650<sup>a</sup>  
 Final departure from Galilee. . . . .1651<sup>a</sup>  
 Final warning of the passion. . . . .1654<sup>a</sup>  
 Final week, importance of. . . . .1655<sup>a</sup>  
 First circuit in Galilee. . . . .1640<sup>a</sup>  
 Fishers of men. . . . .1639<sup>b</sup>  
 Five thousand fed. . . . .1640<sup>b</sup>  
 Forgiveness taught. . . . .1650<sup>a</sup>  
 Four thousand fed. . . . .1648<sup>a</sup>  
 Gadarene demoniac. . . . .1645<sup>b</sup>  
 Galilean ministry. . . . .1638<sup>b</sup>  
 Galilean visit after resurrection. . . . .1666<sup>a</sup>  
 Genealogies. . . . .1634<sup>a</sup>  
 Gerizim or Jerusalem? . . . . .1638<sup>b</sup>  
 Good Shepherd, the 1651<sup>a</sup>  
 Great commission. . . . .1666<sup>b</sup>  
 Greeks visit Jesus. . . . .1657<sup>a</sup>  
 Guard at tomb. . . . .1664<sup>a</sup>  
 Healing at Bethesda 1641<sup>b</sup>  
 Healing of blind man 1643<sup>b</sup>  
 Healing on Sabbath 1642<sup>a</sup>  
 Herod, Jesus before. 1661<sup>b</sup>  
   of Herod. . . . .1378<sup>b</sup> (Dosker)  
 Herod, Jesus' reference to. . . . .1652<sup>a</sup>  
 Heroism of Jesus. . . . .1662<sup>b</sup>  
 Highest good, the. . . . .1643<sup>a</sup>  
 And the Holy Spirit 400<sup>a</sup> (Mullins)  
 Holy Spirit's descent. . . . .1635<sup>a</sup>  
 Image of God. . . . .1451<sup>a</sup> (Edwards)  
 Imprisonment of John the Baptist. . . . .1638<sup>a</sup>  
 Incompleteness. . . . .1631<sup>a</sup>  
 Instructions to the Twelve. . . . .1646<sup>b</sup>  
 Intolerance rebuked 1650<sup>a</sup>  
 Jericho, Jesus at. . . . .1654<sup>b</sup>  
 of Jerusalem. . . . .1618<sup>b</sup> (Masterman)  
 Jesus and His mother. . . . .2002<sup>b</sup> (Sweet)  
 John the Baptist. . . . .1634<sup>b</sup>  
   Birth of. . . . .1631<sup>b</sup>  
   Preaching of. . . . .1634<sup>b</sup>  
   Witness of. . . . .1636<sup>a</sup>  
 John's messengers. . . . .1643<sup>b</sup>  
 Joseph's perplexity. . . . .1632<sup>a</sup>  
 Judas, indignation of. . . . .1655<sup>a</sup>  
 Judas' remorse and death. . . . .1661<sup>a</sup>  
 Judas at the supper 1658<sup>b</sup>

Jesus Christ—*continued*Life—*continued*

- Kingdom, coming of. 1653<sup>b</sup>  
 Language used by. . . . .1832<sup>a</sup> (A. T. Robertson)  
 Law, relation of Jesus to. . . . .1643<sup>a</sup>  
 Lazarus raised. . . . .1653<sup>a</sup>  
 Leaven of Pharisees 1648<sup>a</sup>  
 Leper cured. . . . .1640<sup>b</sup>  
 Light of the world. . . . .1650<sup>b</sup>  
 Logia of Jesus. . . . .1910<sup>b</sup> (Smith)  
 Lord's Supper. . . . .1658<sup>b</sup>; 1921<sup>b</sup> (Gumme); 1924<sup>b</sup> (Dosker)  
   of Passover. . . . .2256<sup>a</sup> (N. Isaacs)  
   of Sacraments. . . . .2636<sup>a</sup> (Lambert)  
 Love of Olivet. . . . .2187<sup>a</sup> (Masterman)  
 Luke's Peraean source. . . . .1651<sup>a</sup>  
 Magi from East. . . . .1633<sup>a</sup>  
 Marriage in Cana. . . . .1637<sup>a</sup>  
 Mary informed regarding her Child 1631<sup>b</sup>  
 Mary and Martha. . . . .1652<sup>b</sup>  
 Massacre of children. . . . .1633<sup>b</sup>  
 Matthew's call and feast. . . . .1641<sup>a</sup>  
 Messiah, Jesus as. . . . .2043<sup>a</sup> (Crichton)  
 Miracle of coin in fish's mouth. . . . .1649<sup>b</sup>  
 Miracle of fishes. . . . .1639<sup>b</sup>  
 Miracle at Nain. . . . .1643<sup>b</sup>  
 Miracle of wine from water. . . . .1637<sup>a</sup>  
 Miracles at death of Jesus. . . . .1663<sup>b</sup>  
 Mother and brothers of Jesus. . . . .1645<sup>a</sup>  
 Murder of John the Baptist. . . . .1646<sup>b</sup>  
 Nazareth synagogue 1639<sup>a</sup>  
 Nicodemus' visit. . . . .1637<sup>b</sup>  
 Nobleman's son healed. . . . .1639<sup>a</sup>  
 Obedience of Jesus. 2175<sup>b</sup> (Crannell)  
 Offices of Jesus. . . . .2021<sup>b</sup> (Edwards)  
 Parables  
   Good Samaritan. . . . .1651<sup>b</sup>  
   Great supper. . . . .1652<sup>a</sup>  
   Lost sheep, coin, and son. . . . .1652<sup>b</sup>  
   Meaning of parables. . . . .1645<sup>a</sup>  
   Pharisee and publican. . . . .1654<sup>a</sup>  
   Pounds. . . . .1655<sup>a</sup>  
   Teaching by parables. . . . .1645<sup>a</sup>  
   Two debtors. . . . .1644<sup>b</sup>  
   Two sons, husbandmen, marriage of prince. . . . .1656<sup>a</sup>

Jesus Christ—*continued*Life—*continued*Parables—*continued*

- Unjust judge. . . . .1653<sup>b</sup>
- Unjust steward  
and Dives. . . . .1653<sup>a</sup>
- Unmerciful servant. . . . .1650<sup>a</sup>
- Virgins, and talents and sheep. 1657<sup>b</sup>
- Paralytic cured. . . . .1640<sup>b</sup>
- Passion week. . . . .1655<sup>a</sup>
- Paul's teachings regarding Jesus . . . .2023<sup>a</sup> (Edwards)
- Peraean ministry. . . . .1651<sup>a</sup>
- Peraean teachings  
and parables. . . . .1651<sup>b</sup>
- Person of Jesus. . . . .2338<sup>a</sup> (Warfield)
- Peter forgiven. . . . .1666<sup>a</sup>
- Peter's denials. . . . .1661<sup>a</sup>
  - First confession. . . . .1647<sup>b</sup>
  - Great confession. . . . .1648<sup>b</sup>
  - Mother-in-law. . . . .1640<sup>a</sup>
- of Pharisees. . . . .2361<sup>a</sup> (J. E. H. Thomson)
- Pharisees offended. . . . .1647<sup>b</sup>
- Pharisees v. Jesus. 1643<sup>a</sup>
- Pilate's attitude  
toward Jesus. . . . .1661<sup>b</sup>
  - Condemnation of  
Jesus. . . . .1662<sup>a</sup>
  - of Pilate, Pontius. 2397<sup>a</sup> (J. M. Wilson)
- Plot against Jesus. . . . .1657<sup>b</sup>
- Plucking grain on  
Sabbath. . . . .1642<sup>a</sup>
- Prayers of Jesus. . . . .2431<sup>b</sup> (Bevan)
- Presentation in  
temple. . . . .1633<sup>a</sup>
- Priests, Jesus before 1660<sup>b</sup>
- Private journey to  
feast. . . . .1650<sup>a</sup>
- Prophetic claims. . . . .1639<sup>a</sup>
- Quirinius' census. . . . .1632<sup>a</sup>
- References to marriage and divorce. 1999<sup>a</sup> (Eager)
- Rejected in Samaria 1651<sup>b</sup>
- Request of James  
and John. . . . .1654<sup>b</sup>
- Resurrection body of  
Jesus. . . . .1664<sup>b</sup>
- Resurrection, events  
of. . . . .1665<sup>a</sup>; 623<sup>b</sup> (J. Dickie);  
2565<sup>b</sup> (Thomas)
  - Importance of. . . . .1664<sup>b</sup>
- Retreat for rest. . . . .1647<sup>b</sup>
- Retreat to Caesarea  
Philippi. . . . .1648<sup>b</sup>
- Retreat to Ephraim 1653<sup>b</sup>
- Return promised. . . . .1649<sup>a</sup>
- Rich young man. . . . .1654<sup>a</sup>
- Sabbath controversies. . . . .1641<sup>b</sup>

Jesus Christ—*continued*Life—*continued*

## Sabbath healings:

- weakness and  
dropsy. . . . .1652<sup>a</sup>
- of Sadducees. . . . .2658<sup>b</sup> (J. E. H. Thomson)
- Sadducees silenced. . . . .1656<sup>b</sup>
- Samaritan leper  
thankful. . . . .1653<sup>b</sup>
- Samaritan woman. . . . .1638<sup>a</sup>
- Sanhedrin, powers  
of. . . . .1660<sup>a</sup>; 2688<sup>b</sup> (Levertoff)
- Second Galilean circuit. . . . .1644<sup>b</sup>
- Sermon on the  
Mount. . . . .1642<sup>b</sup>
- Seventy sent out. . . . .1651<sup>b</sup>
- Shepherds' visit. . . . .1632<sup>b</sup>
- Sign of Jonah. . . . .1644<sup>b</sup>
- Simeon's joy. . . . .1633<sup>a</sup>
- Simon of Cyrene. . . . .1662<sup>b</sup>
- Spear thrust. . . . .1663<sup>b</sup>
- Spiritual body. . . . .493<sup>b</sup> (Morro)
- Storm calmed. . . . .1645<sup>b</sup>
- Superscription of  
cross. . . . .1663<sup>a</sup>
- Syrophenician  
mother. . . . .1648<sup>a</sup>
- of Temple. . . . .2939<sup>a</sup> (Caldecott; Orr)
- Temple tax, the. . . . .1649<sup>b</sup>
- Temptation of Jesus
  - Inward nature of. 1635<sup>b</sup>
  - Three stages of. . . . .1635<sup>b</sup>
  - Time of. . . . .1635<sup>a</sup>
  - Typical character  
of. . . . .1635<sup>b</sup>
- Ten lepers healed. . . . .1653<sup>b</sup>
- Third Galilean circuit. . . . .1646<sup>a</sup>
- Thomas' doubt. . . . .1666<sup>a</sup>
- Threefold office of  
Jesus. . . . .621<sup>a</sup> (Bevan)
- Time in Galilee. . . . .1638<sup>b</sup>
- Titles. . . . .1637<sup>a</sup>
- Tomb of Jesus. . . . .1664<sup>a</sup>
- Transfiguration. . . . .1649<sup>a</sup>
- Trial. . . . .1660<sup>a</sup>; 1670<sup>a</sup> (Maclaren)
  - Before Pilate. . . . .1661<sup>a</sup>; 1672<sup>a</sup> (Maclaren);  
2396<sup>a</sup> (J. M. Wilson)
  - Before Sanhedrin. 1660<sup>b</sup>
- Tribute to Caesar. . . . .1656<sup>b</sup>
- True freedom. . . . .1650<sup>b</sup>
- Tuesday of passion  
week. . . . .1656<sup>a</sup>
- Twelve chosen. . . . .1642<sup>b</sup>
  - Character. . . . .1642<sup>b</sup>
  - Function. . . . .1642<sup>b</sup>
  - Names. . . . .1642<sup>b</sup>
  - Sent out. . . . .1646<sup>a</sup>
- Visits to tomb of  
Jesus. . . . .1665<sup>a</sup>
- Walking on the sea. 1647<sup>a</sup>

Jesus Christ—*continued*Life—*continued*

- Warnings of His death . . . . . 1649<sup>a</sup>
- Warnings to Peter . . . . . 1659<sup>b</sup>
- Washing disciples' feet . . . . . 1658<sup>b</sup>
- Water of Life . . . . . 1650<sup>b</sup>
- Wednesday of final week . . . . . 1657<sup>b</sup>
- Weeping over Jesus . . . . . 1655<sup>b</sup>
- Widow's mites . . . . . 1657<sup>a</sup>
- Woman healed of issue . . . . . 1646<sup>a</sup>
- Woman taken in sin . . . . . 1650<sup>b</sup>
- Would-be disciples . . . . . 1645<sup>a</sup>
- Youthful self-consciousness . . . . . 1634<sup>b</sup>
- Youthful visit to temple . . . . . 1634<sup>a</sup>
- Zacchaeus, Jesus' treatment of . . . . . 1654<sup>b</sup>
- Names
  - Christ . . . . . 1626<sup>a</sup>
  - Jesus . . . . . 1626<sup>a</sup>
- Order of treatment . . . . . 1626<sup>a</sup>
- Outward situation . . . . . 1627<sup>a</sup>
  - Essenes . . . . . 1628<sup>a</sup>
  - Herodian rule . . . . . 1628<sup>a</sup>
  - Palestine . . . . . 1627<sup>a</sup>
  - Palestine provinces . . . . . 1627<sup>b</sup>
  - Pharisees . . . . . 1628<sup>a</sup>
  - Political conditions . . . . . 1627<sup>b</sup>
  - Sadducees . . . . . 1628<sup>a</sup>
  - Scribes . . . . . 1628<sup>a</sup>
- Preparation . . . . . 1627<sup>a</sup>
  - of Apocalyptic Literature . . . . . 161<sup>b</sup> (J. E. H. Thomson)
  - of Eschatology of OT . . . . . 972<sup>a</sup> (Orr)
  - Hebrew and Gentile . . . . . 1627<sup>a</sup>
  - John the Baptist . . . . . 1708<sup>b</sup> (Miller)
    - Birth . . . . . 1631<sup>b</sup>
    - Preaching of . . . . . 1634<sup>b</sup>
    - Relations of Jesus to . . . . . 1710<sup>b</sup> (Miller)
  - Limitations of His knowledge . . . . . 1792<sup>b</sup> (Easton)
  - Magi . . . . . 1633<sup>a</sup>
    - of Magi . . . . . 1962<sup>a</sup> (Tisdall)
    - of Star of the Magi . . . . . 2848<sup>a</sup> (Maunder)
  - OT expectations . . . . . 1627<sup>a</sup>
  - Post-exilic expectations . . . . . 1627<sup>a</sup>
  - Virgin-birth, objections to . . . . . 1633<sup>b</sup>
    - of Mary (Virgin) . . . . . 2001<sup>b</sup> (Sweet)
    - of Virgin-birth . . . . . 3052<sup>a</sup> (Sweet)
- Problems in His life . . . . . 1629<sup>a</sup>
- Apocalyptic beliefs . . . . . 1630<sup>a</sup>; 972<sup>a</sup> (Orr)
- Apocalyptic ideas . . . . . 1630<sup>a</sup>

Jesus Christ—*continued*Problems in His life—*continued*

- Authority of Jesus . . . . . 336<sup>a</sup> (Rees)
- Descent into lower world . . . . . 200<sup>a</sup> (Hutchison)
- Difficulties with miracles . . . . . 1629<sup>a</sup>
- of God . . . . . 1261<sup>a</sup> (Rees)
- Kingdom, present or future . . . . . 1630<sup>a</sup>
- Kingly office of . . . . . 620<sup>b</sup> (Bevan)
- Messianic element . . . . . 1629<sup>b</sup>
- Messianic idea a growth . . . . . 1629<sup>b</sup>
- Miracles affirmed . . . . . 1629<sup>b</sup>
- Moral character . . . . . 1630<sup>b</sup>
- Offices of . . . . . 616<sup>b</sup> (Bevan)
  - of Intercession . . . . . 1484<sup>a</sup> (Bevan)
- Omniscience of . . . . . 1792<sup>b</sup> (Easton)
- Parables . . . . . 1645<sup>a</sup>; 2243<sup>a</sup> (Schodde)
- Person of . . . . . 627<sup>b</sup> (Orr); 2338<sup>a</sup> (Warfield)
- of Priest, High . . . . . 2441<sup>b</sup> (Reeve)
- Priesthood of . . . . . 618<sup>a</sup> (Bevan)
- As prophet . . . . . 618<sup>a</sup> (Bevan)
- Religion of . . . . . 625<sup>a</sup> (Orr)
- Sinlessness . . . . . 1630<sup>b</sup>
- Sinlessness and Messiahship . . . . . 1631<sup>a</sup>
- Sinlessness and Virgin-birth . . . . . 1630<sup>b</sup>
- Sources . . . . . 1626<sup>a</sup>
  - Agrapha of . . . . . 1903<sup>a</sup> (Cowan)
  - Characteristics in Mark . . . . . 1988<sup>a</sup> (Farmer)
  - Denial of existence . . . . . 1626<sup>b</sup>
  - Extra-Christian . . . . . 1626<sup>b</sup>
  - Fourth Gospel . . . . . 1627<sup>a</sup>; 1725<sup>a</sup> (Iverach)
  - General . . . . . 1626<sup>b</sup>
  - Gospels . . . . . 1626<sup>a</sup>
    - of John, Gospel of . . . . . 1720<sup>b</sup> (Iverach)
    - of Matthew, Gospel of . . . . . 2011<sup>a</sup> (Schodde)
  - of Logia . . . . . 1910<sup>a</sup> (Smith)
  - Synoptic Gospels . . . . . 1626<sup>b</sup>; 1284<sup>a</sup> (Iverach)
- Teachings
  - Ablution . . . . . 14<sup>b</sup> (Eager)
  - Abstinence . . . . . 25<sup>b</sup> (Eager)
  - Advent, hope of . . . . . 1668<sup>a</sup>
  - After ascension . . . . . 1667<sup>a</sup>
  - Beatitudes . . . . . 419<sup>a</sup> (Lambert)
  - Blasphemy . . . . . 1644<sup>b</sup>; 485<sup>b</sup> (Rees)
  - Claims to kingship . . . . . 1802<sup>a</sup> (M'Caig)
  - Comparison with author of Ep. of James . . . . . 1564<sup>b</sup> (Hayes)
  - Cross and resurrection, significance of . . . . . 1667<sup>b</sup>
  - Divorce . . . . . 865<sup>a</sup> (Caverno)
  - Ethics of, in Synoptic Gospels . . . . . 1285<sup>b</sup> (Iverach)
  - of Ethics of Jesus . . . . . 1026<sup>a</sup> (Stalker)



Jesus Christ—*continued*Teachings—*continued*

- Faithfulness . . . . . 1091<sup>a</sup> (Hodge)  
 Family . . . . . 1096<sup>b</sup> (Caverno)  
 The Finisher . . . . . 1111<sup>b</sup> (W. L. Walker)  
 Forgiveness . . . . . 1133<sup>a</sup> (Morro)  
 Gospel, Jesus and  
 the . . . . . 624<sup>b</sup> (J. Dickie)  
 Gospels and Epis-  
 tles . . . . . 1667<sup>b</sup>  
 On guilt . . . . . 1309<sup>b</sup> (Rall)  
 of Hebrews, Ep. to . 2024<sup>b</sup> (Edwards)  
 Holy Spirit and blas-  
 phemy . . . . . 486<sup>a</sup> (Rees)  
 Law in NT . . . . . 1844<sup>a</sup> (M'Caig)  
 Light, Jesus as . . . . . 1891<sup>b</sup> (Pratt)  
 Literature . . . . . 1668<sup>a</sup>  
 Lordship of Christ . 1667<sup>b</sup>  
 Parousia . . . . . 2250<sup>a</sup> (Easton)  
 Person of Jesus . . . . . 1667<sup>b</sup>  
 Resurrection . . . . . 2563<sup>b</sup> (Easton)  
 Revelation through  
 Spirit . . . . . 1667<sup>a</sup>  
 Sabbath . . . . . 2631<sup>b</sup> (Sampey)  
 Sacrifice . . . . . 2652<sup>a</sup> (Williams)  
 Salvation . . . . . 2667<sup>a</sup> (Easton)  
 Self-surrender . . . . . 2716<sup>a</sup> (Pollard)  
 Sermon on the  
 Mount . . . . . 2732<sup>b</sup> (Miller)  
 Shepherd, Jesus as . 2764<sup>a</sup> (Patch)  
 Sin . . . . . 2800<sup>a</sup> (McConnell)  
 Teacher, Jesus as . . 1991<sup>b</sup> (Farmer)  
 Testimony to in-  
 spiration . . . . . 1476<sup>b</sup> (Warfield)  
 Use of parables . . . 2243<sup>b</sup> (Schodde)  
 Use of "Paraclete". 2245<sup>b</sup> (Mullins)

As a thinker, in Synop-  
tic Gospels . . . . . 1286<sup>a</sup> (Iverach)

## Jesus Christ, Arrest and

- Trial of . . . . . 1668<sup>b</sup> (Maclaren)  
 Introduction . . . . . 1668<sup>b</sup>  
 Arrest in garden . . 1669<sup>b</sup>  
 Causes . . . . . 1669<sup>a</sup>  
 Difficulties of sub-  
 ject . . . . . 1668<sup>b</sup>  
 Jewish and Roman  
 law . . . . . 1668<sup>b</sup>  
 Place . . . . . 1669<sup>a</sup>  
 Preparation for . . . 1669<sup>a</sup>  
 Removal to city . . . 1669<sup>b</sup>  
 of Jesus Christ . . . . 1660<sup>a</sup> (Orr)  
 Jewish trial . . . . . 1670<sup>a</sup>  
 Bearing on . . . . . 1670<sup>a</sup>  
 Browbeating judge,  
 a . . . . . 1671<sup>a</sup>  
 Condemnation for  
 blasphemy . . . . . 1671<sup>b</sup>  
 Criminal trials . . . . 1670<sup>a</sup>  
 False witnesses . . . . 1671<sup>a</sup>  
 Jewish law, the . . . . 1670<sup>a</sup>  
 Mishna, the . . . . . 1670<sup>a</sup>

Jesus Christ, Arrest and Trial of—*continued*Jewish trial—*continued*

- Morning session . . . 1671<sup>a</sup>  
 Night trial . . . . . 1670<sup>b</sup>  
 Power of Sanhedrin . 1671<sup>b</sup>  
 Preliminary exam-  
 ination . . . . . 1670<sup>b</sup>  
 Summary . . . . . 1671<sup>b</sup>  
 of Law in NT . . . . . 1846<sup>b</sup> (M'Caig)  
 Roman trial . . . . . 1672<sup>a</sup>  
 Accusations renewed 1672<sup>b</sup>  
 Acquittal by Pilate . 1672<sup>b</sup>  
 Attempt to evade  
 full trial . . . . . 1672<sup>b</sup>  
 Barabbas or Jesus . . 1673<sup>a</sup>  
 "Behold the man!" . 1673<sup>a</sup>  
 Final accusation . . . 1672<sup>b</sup>  
 Pilate, Jesus before . 1672<sup>a</sup>  
 Pilate's surrender . . 1673<sup>b</sup>  
 Pilate washes hands 1673<sup>b</sup>  
 Sent to Herod . . . . 1673<sup>a</sup>  
 Sentence of Jesus . . 1673<sup>b</sup>  
 Summary . . . . . 1673<sup>b</sup>  
 Sinlessness of Jesus . . 2805<sup>b</sup> (Dunelm)  
 Son of God . . . . . 2826<sup>b</sup> (Stalker)  
 of Temple . . . . . 2939<sup>a</sup> (Caldecott; Orr)  
 Jesus, Genealogy of . . 1196<sup>a</sup> (Sweet)  
 Jesus Justus . . . . . 1674<sup>a</sup> (Rutherford)  
 Jesus (Sirach) . . . . . 2806<sup>b</sup> (T. W. Davies)  
 Jesus, Wisdom of  
 of Sirach . . . . . 2806<sup>b</sup> (T. W. Davies)  
 Jether . . . . . 1674<sup>a</sup> (Roberts)  
 of Jethro . . . . . 1674<sup>a</sup> (Crichton)  
 Jetheth . . . . . 1674<sup>a</sup>  
 Jethlah  
 of Ithlah . . . . . 1543<sup>b</sup>  
 Jethro . . . . . 1674<sup>a</sup> (Crichton)  
 Character of . . . . . 1675<sup>a</sup>  
 Counsel to Moses . . . 1674<sup>b</sup>  
 Father-in-law of Moses 1674<sup>b</sup>  
 Relation to Hobab and  
 Reuel . . . . . 1674<sup>b</sup>  
 Visit to Moses in  
 desert . . . . . 1674<sup>b</sup>  
 Jetur . . . . . 1675<sup>a</sup>  
 of Ituraea . . . . . 1544<sup>a</sup> (Ewing)  
 Jeuel . . . . . 1675<sup>a</sup>  
 of Jeiel . . . . . 1586<sup>b</sup> (Roberts)  
 Jeush . . . . . 1675<sup>a</sup>  
 Jeuz . . . . . 1675<sup>a</sup>  
 Jew . . . . . 1675<sup>a</sup> (Orr)  
 of Israel, Religion of . 1530<sup>b</sup> (Orelli)  
 of Languages of OT . . 1832<sup>a</sup> (Weir)  
 Jewel . . . . . 1675<sup>b</sup> (Orr)  
 of Nose-jewels . . . . 2156<sup>a</sup> (Pollard)  
 of Ornament . . . . . 2201<sup>b</sup> (Doolan)  
 of Stones, Precious . . 2856<sup>a</sup> (Fletcher)  
 Jewess . . . . . 1675<sup>a</sup> (Orr)  
 Jewish . . . . . 1675<sup>a</sup> (Orr)  
 of Architecture . . . . 234<sup>b</sup> (A. C. Dickie)  
 of Cult, Suppression of 17<sup>b</sup> (Hirsch)  
 of Pseudo-Messiahs . . 629<sup>a</sup> (Orr)

- Jewry . . . . . 1675<sup>b</sup>  
 cf Judaea . . . . . 1757<sup>a</sup> (Masterman)
- Jews  
 cf Jew . . . . . 1675<sup>a</sup> (Orr)
- Jezaniah . . . . . 1675<sup>b</sup>  
 cf Jaazaniah . . . . . 1546<sup>a</sup> (Roberts)
- Jezebel . . . . . 1675<sup>b</sup> (Roberts)  
 cf Ahab . . . . . 78<sup>b</sup> (Mosiman)  
 cf Baal . . . . . 345<sup>a</sup> (Sayce)  
 Character of . . . . . 1676<sup>a</sup>  
 Death of . . . . . 1676<sup>a</sup>  
 cf Elijah . . . . . 930<sup>b</sup> (Farr)  
 cf Jehu . . . . . 1585<sup>a</sup> (Caldecott)  
 Persecution of proph-  
 ets . . . . . 1676<sup>a</sup>  
 Plot against Naboth of  
 Jezreel . . . . . 1676<sup>a</sup>  
 In Revelation 2 20 . . . . . 1676<sup>b</sup>
- Jezelus . . . . . 1676<sup>b</sup>
- Jezer . . . . . 1676<sup>b</sup>
- Jezerites . . . . . 1676<sup>b</sup>
- Jeziiah  
 cf Izziah . . . . . 1545<sup>b</sup>
- Jeziel . . . . . 1677<sup>a</sup>
- Jezliah  
 cf Izliah . . . . . 1545<sup>b</sup>
- Jezoar  
 cf Izhar . . . . . 1545<sup>b</sup>
- Jezrahiah  
 cf Izrahiah . . . . . 1545<sup>b</sup>
- Jezreel . . . . . 1677<sup>a</sup> (Ewing)  
 cf Harod, Well of . . . . . 1340<sup>b</sup> (Ewing)  
 cf Jeruel . . . . . 1595<sup>b</sup>  
 cf Lo-ammi . . . . . 1907<sup>a</sup> (Lees)  
 Location . . . . . 1677<sup>a</sup>  
 cf Naboth . . . . . 2108<sup>a</sup> (Wallace)  
 Residence of Ahab . . . . . 1677<sup>a</sup>  
 Site of Naboth's vine-  
 yard . . . . . 1677<sup>a</sup>
- Jezreel, Vale of  
 cf Esdraelon, Plain of . . . . . 993<sup>a</sup> (Ewing)
- Jezreelite . . . . . 1677<sup>b</sup>
- Jezreelitess . . . . . 1677<sup>b</sup>
- Jezrielus (Hierielus) . . . . . 1677<sup>b</sup>
- Jibsam  
 cf Ibsam . . . . . 1446<sup>b</sup>
- Jidlaph . . . . . 1677<sup>b</sup>
- Jimna, Jimnah . . . . . 1677<sup>b</sup>  
 cf Imnah . . . . . 1461<sup>b</sup>
- Jimnites . . . . . 1677<sup>b</sup>  
 cf Innites . . . . . 1461<sup>b</sup>
- Jiphtah  
 cf Iphtah . . . . . 1491<sup>a</sup>
- Jiphtah-el  
 cf Iphtah-el . . . . . 1491<sup>a</sup> (Ewing)
- Joab . . . . . 1677<sup>b</sup> (Roberts); 13<sup>a</sup>  
 (Mack); 15<sup>a</sup> (Mar-  
 golis); 795<sup>a</sup> (Weir)
- Absalom's relations  
 with . . . . . 1678<sup>a</sup>  
 Character of . . . . . 1678<sup>b</sup>  
 Contest with Abner . . . . . 1677<sup>b</sup>
- Joab—*continued*  
 David's commander-  
 in-chief . . . . . 1677<sup>b</sup>  
 Death of . . . . . 1678<sup>a</sup>  
 cf Ge-harashim . . . . . 1182<sup>a</sup>  
 Murder of Abner . . . . . 1677<sup>b</sup>  
 Murder of Amasa . . . . . 1678<sup>a</sup>
- Joachaz . . . . . 1678<sup>b</sup>
- Joacim  
 cf Joakim . . . . . 1679<sup>a</sup> (Hutchison)
- Joadanus . . . . . 1678<sup>b</sup>
- Joah . . . . . 1678<sup>b</sup>  
 cf Joha . . . . . 1695<sup>a</sup>
- Joahaz . . . . . 1678<sup>b</sup>  
 cf Jehoahaz . . . . . 1574<sup>b</sup> (Caldecott); 1575<sup>a</sup>  
 (Genung)  
 cf Northern Israel . . . . . 1528<sup>b</sup> (Weir)
- Joakim (Joacim) . . . . . 1679<sup>a</sup> (Hutchison)
- Joanan . . . . . 1679<sup>a</sup>
- Joanna . . . . . 1679<sup>a</sup> (Kerr)
- Joannes . . . . . 1679<sup>a</sup>
- Joarib . . . . . 1679<sup>a</sup>
- Joash . . . . . 1575<sup>b</sup> (Caldecott); 1679<sup>a</sup>  
 (Roberts); 1679<sup>b</sup>
- Joatham . . . . . 1679<sup>b</sup>  
 cf Jotham . . . . . 1754<sup>a</sup> (Caldecott)
- Job . . . . . 1679<sup>b</sup> (Genung)  
 cf Boil . . . . . 494<sup>a</sup> (Macalister)
- Job, Book of . . . . . 1679<sup>b</sup> (Genung)  
 Age and setting . . . . . 1686<sup>b</sup>  
 Contact with fact  
 slight . . . . . 1686<sup>b</sup>  
 Jehoiachin's impris-  
 onment, date . . . . . 1687<sup>a</sup>  
 Literature . . . . . 1687<sup>b</sup>  
 Parallels to Job . . . . . 1687<sup>b</sup>  
 Prison setting of  
 book . . . . . 1687<sup>a</sup>  
 Relation to Wisdom  
 literature . . . . . 1687<sup>a</sup>
- cf Date of Job . . . . . 314<sup>b</sup>
- Familiar story . . . . . 1680<sup>a</sup>
- cf Josiah . . . . . 1751<sup>b</sup> (Genung)
- Literary form . . . . . 1680<sup>a</sup>  
 Characters of story . . . . . 1680<sup>b</sup>  
 Literary art . . . . . 1680<sup>a</sup>  
 Literary style . . . . . 1681<sup>a</sup>  
 Setting of story . . . . . 1680<sup>b</sup>
- cf Palestine . . . . . 2218<sup>a</sup> (Conder)
- Position in canon . . . . . 1680<sup>a</sup>
- Problem . . . . . 1685<sup>b</sup>  
 Critical views dis-  
 missed . . . . . 1686<sup>a</sup>
- Job, the hero, the  
 answer . . . . . 1686<sup>b</sup>
- Problems of the age . . . . . 1686<sup>a</sup>
- Purpose of the book . . . . . 1685<sup>b</sup>
- Theodicy of Job . . . . . 1686<sup>a</sup>
- cf Proverbs, Book of . . . . . 2471<sup>b</sup> (Genung)
- cf Providence . . . . . 2478<sup>a</sup> (Tillett)
- cf Resurrection . . . . . 2563<sup>a</sup> (Easton)

- Job, Book of—*continued*
- The story . . . . . 1681<sup>a</sup>
    - An inner experience 1681<sup>a</sup>
    - Charges against Job. 1683<sup>b</sup>
    - Debate, the. . . . . 1682<sup>a</sup>
    - Demanding a hearing from God. . . . . 1683<sup>a</sup>
    - Does death end all? 1683<sup>a</sup>
    - Elihu's appearance. . . . . 1684<sup>b</sup>
    - End of debate. . . . . 1684<sup>b</sup>
    - Fate of wicked men 1684<sup>a</sup>
    - Forgers of lies. . . . . 1683<sup>a</sup>
    - Job's prosperity . . . . . 1681<sup>a</sup>
    - Job's review of his life. . . . . 1684<sup>b</sup>
    - Job's vindicator. . . . . 1683<sup>b</sup>
    - Mystery of suffering 1682<sup>b</sup>
    - No Divine umpire. . . . . 1683<sup>a</sup>
    - Prosperity of evil. . . . . 1684<sup>a</sup>
    - Questions from nature. . . . . 1685<sup>a</sup>
    - Rebuke of the friends. . . . . 1685<sup>a</sup>
    - Restoration of Job. . . . . 1685<sup>b</sup>
    - Satan's challenge. . . . . 1681<sup>b</sup>
    - Three friends, the. . . . . 1682<sup>a</sup>
    - Voice from the storm 1685<sup>a</sup>
  - Job, Testament of
    - cf Apocalyptic Literature. . . . . 161<sup>b</sup> (J. E. H. Thomson)
  - Jobab. . . . . 1688<sup>a</sup>
    - cf Table of Nations. . . . . 2898<sup>b</sup> (Pinches)
  - Job's Well
    - cf Jerusalem. . . . . 1598<sup>a</sup> (Masterman)
  - Jochebed. . . . . 1688<sup>a</sup>
  - Jod. . . . . 1688<sup>a</sup>
    - cf Alphabet. . . . . 103<sup>b</sup> (Richardson)
    - cf Jot. . . . . 1753<sup>b</sup> (Easton)
    - cf Yodh. . . . . 3126<sup>a</sup>
  - Joda. . . . . 1688<sup>a</sup>
  - Joed. . . . . 1688<sup>a</sup>
  - Joel. . . . . 1688<sup>a</sup> (Roberts)
  - Joel, Book of. . . . . 1688<sup>a</sup> (J. Robertson)
    - Allegorical interpretation . . . . . 1690<sup>a</sup>
    - Connection with NT. . . . . 1695<sup>a</sup>
    - Contents
      - Ch 1: drought and locusts. . . . . 1688<sup>b</sup>
      - Ch 2: Jeh's jealousy for His people. . . . . 1689<sup>a</sup>
    - Date indications. . . . . 1690<sup>a</sup>
    - Future prospects. . . . . 1689<sup>b</sup>
    - Language and style. . . . . 1690<sup>b</sup>
    - Literal interpretation. . . . . 1690<sup>a</sup>
    - Literary form. . . . . 1688<sup>b</sup>
    - Outline. . . . . 1688<sup>b</sup>
    - Placed among early books. . . . . 1690<sup>a</sup>
    - Political arguments regarding date. . . . . 1691<sup>b</sup>
    - Prophet, the. . . . . 1688<sup>b</sup>
  - Joel, Book of—*continued*
    - Quotations from earlier books. . . . . 1691<sup>a</sup>
    - cf Reaiah. . . . . 2534<sup>a</sup>
    - References to foreign nations. . . . . 1692<sup>a</sup>
    - Religious arguments regarding date. . . . . 1691<sup>b</sup>
    - Resemblances to Amos 1690<sup>b</sup>
    - Review of men's theory. . . . . 1694<sup>a</sup>
    - Ritualistic arguments regarding date. . . . . 1691<sup>b</sup>
    - Special expressions in . . . . . 1693<sup>a</sup>
    - Joelah. . . . . 1695<sup>a</sup>
    - Joezer. . . . . 1695<sup>a</sup>
    - Jogbehah. . . . . 1695<sup>a</sup>
    - Jogli. . . . . 1695<sup>a</sup>
    - Joha. . . . . 1695<sup>a</sup>
      - cf Joah. . . . . 1678<sup>b</sup>
    - Johanah. . . . . 1695<sup>b</sup> (Roberts)
      - cf Jehohanah. . . . . 1577<sup>b</sup> (Roberts)
    - Johannes
      - cf Joannes. . . . . 1679<sup>a</sup>
    - Johannine Theology, The 1695<sup>b</sup> (Law)
      - Antecedents. . . . . 1696<sup>a</sup>
        - Gentile thought contact. . . . . 1696<sup>b</sup>
        - Gnosticism, reaction from. . . . . 1697<sup>a</sup>
        - Odes of Solomon, influence of. . . . . 1696<sup>b</sup>
        - Relations to other NT writings. . . . . 1696<sup>a</sup>
        - Transition days. . . . . 1696<sup>a</sup>
        - Writer's personality 1696<sup>a</sup>
      - Church and sacraments 1704<sup>b</sup>
        - Church, the. . . . . 1704<sup>b</sup>
        - Lord's Supper. . . . . 1704<sup>b</sup>
        - Sacraments, the. . . . . 1704<sup>b</sup>
      - Doctrine of God. . . . . 1697<sup>a</sup>
        - Life, God as. . . . . 1697<sup>b</sup>
        - Life, types of the
          - Divine. . . . . 1697<sup>b</sup>
          - Light, God as. . . . . 1697<sup>b</sup>
          - Love, God as. . . . . 1698<sup>a</sup>
          - Righteousness, God as. . . . . 1698<sup>a</sup>
          - Spirit, God as. . . . . 1697<sup>a</sup>
      - Eschatology. . . . . 1705<sup>a</sup>
        - Antichrist. . . . . 1705<sup>b</sup>
        - Christ's coming perpetual. . . . . 1705<sup>a</sup>
        - Historic basis. . . . . 1705<sup>a</sup>
        - Idealism. . . . . 1705<sup>a</sup>
        - Judgment. . . . . 1705<sup>b</sup>
        - Moral values. . . . . 1705<sup>b</sup>
        - Parousia, the. . . . . 1705<sup>b</sup>
          - Nature of. . . . . 1706<sup>a</sup>
          - Relation of, to believers. . . . . 1706<sup>a</sup>
        - Resurrection. . . . . 1705<sup>b</sup>

Johannine Theology, The—*continued*

- Eternal life . . . . . 1702<sup>b</sup>  
 Abiding in God . . . . . 1703<sup>b</sup>  
 Children of God . . . . . 1703<sup>b</sup>  
 Development of the  
 doctrine . . . . . 1703<sup>a</sup>  
 Ethical character of 1702<sup>b</sup>  
 Greek influence . . . . . 1702<sup>b</sup>  
 Metaphysical aspect 1702<sup>b</sup>  
 of Gospel . . . . . 1281<sup>a</sup> (Bauslin)  
 of Gospels, Synoptic . . . . . 1281<sup>b</sup> (Iverach)  
 Holy Spirit . . . . . 1700<sup>a</sup>  
 Deity implied . . . . . 1701<sup>a</sup>  
 In First Epistle . . . . . 1700<sup>b</sup>  
 In Fourth Gospel . . . . . 1700<sup>a</sup>  
 Perpetuates work of  
 Christ . . . . . 1700<sup>b</sup>  
 Personality of . . . . . 1701<sup>a</sup>  
 As Teacher . . . . . 1700<sup>b</sup>  
 Human nature and its  
 regeneration . . . . . 1703<sup>b</sup>  
 Classes distinguished 1704<sup>a</sup>  
 World, the . . . . . 1704<sup>a</sup>  
 Incarnation . . . . . 1699<sup>a</sup>  
 In First Epistle . . . . . 1699<sup>b</sup>  
 Logos doctrine in  
 Fourth Gospel . . . . . 1699<sup>b</sup>  
 Logos idea in Hebrew  
 literature . . . . . 1699<sup>a</sup>  
 Necessity of . . . . . 1700<sup>a</sup>  
 Reality of human life  
 of Christ . . . . . 1699<sup>b</sup>  
 Theme of Fourth  
 Gospel . . . . . 1699<sup>b</sup>  
 of John, the Apostle . . . . . 1706<sup>b</sup> (Iverach)  
 of John, Epistles of . . . . . 1711<sup>a</sup> (Law)  
 of Light . . . . . 1890<sup>b</sup> (Pratt)  
 Literature . . . . . 1706<sup>b</sup>  
 of Mediation . . . . . 2025<sup>a</sup> (Edwards)  
 of Parousia . . . . . 2251<sup>a</sup> (Easton)  
 of Person of Christ . . . . . 2342<sup>a</sup> (Warfield)  
 of Propitiation . . . . . 2467<sup>a</sup> (Carver)  
 of Salvation . . . . . 2665<sup>a</sup> (Easton)  
 Sin and pardon . . . . . 1701<sup>b</sup>  
 Harmony with other  
 NT teaching . . . . . 1702<sup>a</sup>  
 Nature of sin . . . . . 1701<sup>b</sup>  
 Not elaborated in Jo-  
 hannine writings 1701<sup>b</sup>  
 Propitiation in the  
 First Epistle . . . . . 1702<sup>a</sup>  
 Propitiation in the  
 Fourth Gospel . . . . . 1701<sup>b</sup>  
 of Sin . . . . . 2798<sup>b</sup> (McConnell)  
 Teachings regarding  
 person of Christ . . . . . 2342<sup>a</sup>  
 John (Apoc) . . . . . 1706<sup>b</sup> (Hutchison)  
 of Asmoneans . . . . . 283<sup>a</sup> (Dosker)  
 of Maccabaeus . . . . . 1946<sup>a</sup> (Hutchison)  
 John, the Apostle . . . . . 1706<sup>b</sup> (Iverach)  
 of Antichrist in Epistles  
 of . . . . . 155<sup>a</sup> (J. E. H. Thomson)

John, the Apostle—*continued*

- of Baptism of . . . . . 396<sup>b</sup> (Dau)  
 Character of . . . . . 1708<sup>b</sup>  
 Ephesian traditions . . . . . 1708<sup>a</sup>  
 Relation to John, the  
 presbyter . . . . . 1708<sup>a</sup>  
 of Johannine Theology 1695<sup>b</sup> (Law)  
 of John, Epistles of . . . . . 1711<sup>a</sup> (Law)  
 of John, Gospel of . . . . . 1720<sup>a</sup> (Iverach)  
 of Literature, Sub-  
 apostolic . . . . . 1901<sup>a</sup> (Cowan)  
 of Machaerus . . . . . 1959<sup>a</sup> (Ewing)  
 Martyrdom, alleged  
 early . . . . . 1707<sup>b</sup>  
 Residence in Ephe-  
 sus . . . . . 1707<sup>b</sup>  
 of Patmos . . . . . 2263<sup>b</sup> (Harry)  
 of Revelation of John . . . . . 2582<sup>b</sup> (Orr)  
 Sources . . . . . 1706<sup>b</sup>  
 Acts and Galatians . . . . . 1707<sup>b</sup>  
 Johannine writings . . . . . 1706<sup>b</sup>  
 NT record . . . . . 1706<sup>b</sup>  
 Synoptic Gospels . . . . . 1707<sup>a</sup>  
 John the Baptist . . . . . 1708<sup>b</sup> (Miller); 1131<sup>a</sup>  
 (W. Evans)  
 Baptism, its origin . . . . . 1709<sup>b</sup>  
 Baptism of Jesus . . . . . 1710<sup>a</sup>  
 Death of . . . . . 1710<sup>b</sup>  
 Disciples of . . . . . 1710<sup>b</sup>  
 Dress and manner . . . . . 1709<sup>a</sup>  
 Early life . . . . . 1709<sup>a</sup>  
 Estimate of, by Jesus . . . . . 1711<sup>a</sup>  
 of Forerunner . . . . . 1131<sup>a</sup> (W. Evans)  
 Imprisonment . . . . . 1710<sup>a</sup>  
 of Jesus Christ . . . . . 1631<sup>b</sup>; 1634<sup>b</sup> (Orr)  
 Message . . . . . 1709<sup>b</sup>  
 Place and date . . . . . 1709<sup>a</sup>  
 Proselyte baptism . . . . . 1710<sup>a</sup>  
 Relation to Jesus . . . . . 1710<sup>b</sup>  
 Severity of . . . . . 1709<sup>b</sup>  
 Sources and parentage 1709<sup>a</sup>  
 of Witness to Jesus . . . . . 1636<sup>a</sup> (Orr)  
 John, the Epistles of . . . . . 1711<sup>a</sup> (Law)  
 Canonicity and author-  
 ship . . . . . 1715<sup>b</sup>; 1718<sup>a</sup>  
 Critical views . . . . . 1715<sup>b</sup>  
 Internal evidence . . . . . 1715<sup>b</sup>  
 Traditional views . . . . . 1715<sup>b</sup>  
 Traditional views,  
 reasonable . . . . . 1716<sup>a</sup>  
 Character . . . . . 1711<sup>b</sup>  
 Personal . . . . . 1711<sup>b</sup>  
 Style and diction . . . . . 1712<sup>b</sup>  
 Themes, theological  
 and ethical . . . . . 1712<sup>a</sup>  
 Traits of writer . . . . . 1712<sup>a</sup>  
 Elect lady, the . . . . . 1719<sup>a</sup>; 925<sup>a</sup> (Law)  
 First Epistle . . . . . 1711<sup>b</sup>  
 of Johannine Theology 1695<sup>b</sup> (Law)  
 of John, the Apostle . . . . . 1706<sup>b</sup> (Iverach)  
 of John, Gospel of . . . . . 1720<sup>a</sup> (Iverach)  
 of Lady . . . . . 1821<sup>b</sup>

- John, the Epistles of—*continued*  
 Literature . . . . . 1717<sup>b</sup>  
 Polemical aim . . . . . 1712<sup>b</sup>  
 Antinomianism . . . . . 1713<sup>b</sup>  
 Cerinthus . . . . . 1714<sup>a</sup>  
 Docetism . . . . . 1713<sup>a</sup>  
 Gnosticism . . . . . 1713<sup>a</sup>  
 Indignation of the  
 writer . . . . . 1713<sup>b</sup>  
 Presbyterian (elder) . . . . . 1718<sup>a</sup>  
 Relations to Fourth  
 Gospel . . . . . 1716<sup>b</sup>  
 Argument for unity  
 of authorship . . . . . 1717<sup>a</sup>  
 Common features . . . . . 1716<sup>b</sup>  
 Differences ex-  
 plained . . . . . 1716<sup>b</sup>  
 Priority considered . . . . . 1717<sup>b</sup>  
 Similar vocabulary . . . . . 1716<sup>b</sup>  
 Second Epistle . . . . . 1719<sup>a</sup>  
 Structure and contents 1714<sup>a</sup>  
 Christian life . . . . . 1714<sup>b</sup>  
 Divine sonship . . . . . 1714<sup>b</sup>  
 Order of themes . . . . . 1714<sup>a</sup>  
 Righteousness, love,  
 etc . . . . . 1715<sup>a</sup>  
 Themes of the Epistles 1719<sup>b</sup>  
 Third Epistle . . . . . 1718<sup>b</sup>  
 John, Gospel of . . . . . 1720<sup>a</sup> (Iverach)  
 External evidence . . . . . 1720<sup>b</sup>  
 Critical work . . . . . 1722<sup>a</sup>  
 Ignatius . . . . . 1721<sup>b</sup>  
 Irenaeus . . . . . 1721<sup>a</sup>  
 Known at end of 2d  
 century . . . . . 1720<sup>b</sup>  
 Presbyterian, John the 1721<sup>b</sup>  
 Summary . . . . . 1721<sup>b</sup>  
 Tatian . . . . . 1721<sup>a</sup>  
 Theophilus . . . . . 1721<sup>a</sup>  
 of Fourth Gospel . . . . . 465<sup>b</sup> (Orr)  
 of Gospels, Synoptic . . . . . 1281<sup>b</sup> (Iverach)  
 Internal evidence, char-  
 acteristics . . . . . 1722<sup>a</sup>  
 Critical presuppo-  
 sitions . . . . . 1722<sup>a</sup>  
 Eye-witness records 1723<sup>b</sup>  
 Importance of inter-  
 nal testimony . . . . . 1722<sup>a</sup>  
 Personal record . . . . . 1723<sup>b</sup>  
 Relation to Synop-  
 tics . . . . . 1722<sup>b</sup>  
 Reminiscences il-  
 lustrated . . . . . 1724<sup>a</sup>  
 Time covered . . . . . 1723<sup>a</sup>  
 Introduction . . . . . 1720<sup>a</sup>  
 Date discussed . . . . . 1720<sup>b</sup>  
 Scope . . . . . 1720<sup>a</sup>  
 of Jesus Christ . . . . . 1627<sup>a</sup> (Orr)  
 of John, the Apostle . . . . . 1706<sup>b</sup> (Iverach)  
 of John, Epistles of . . . . . 1718<sup>a</sup> (Law)  
 of Logos . . . . . 1911<sup>b</sup> (Alexander)  
 of Person of Christ . . . . . 2342<sup>b</sup> (Warfield)
- John, Gospel of—*continued*  
 Progress and develop-  
 ment . . . . . 1724<sup>b</sup>  
 Faith and unbelief . . . . . 1726<sup>a</sup>  
 Logos doctrine . . . . . 1725<sup>b</sup>  
 Messiahship . . . . . 1726<sup>b</sup>  
 Person of Jesus . . . . . 1725<sup>a</sup>  
 of Prologue . . . . . 2458<sup>b</sup>  
 of Relations to 1 John 1716<sup>b</sup> (Law)  
 of Teaching on salva-  
 tion . . . . . 2670<sup>a</sup> (Easton)  
 John Hyrcanus, the Mac-  
 cabee . . . . . 285<sup>a</sup> (Dosker)  
 of Maccabaeus . . . . . 1947<sup>a</sup> (Hutchison)  
 John Mark . . . . . 1986<sup>b</sup> (Farmer)  
 John the Presbyterian  
 of Literature, Sub-  
 apos . . . . . 1901<sup>a</sup> (Cowan)  
 John, the Revelation of . . . . . 2582<sup>b</sup> (Orr)  
 Joiada . . . . . 1727<sup>a</sup>  
 of Jehoiada . . . . . 1578<sup>a</sup> (Roberts)  
 Joiakim . . . . . 1727<sup>a</sup>  
 of Jehoiakim . . . . . 1579<sup>a</sup> (Genung)  
 of Jokim . . . . . 1727<sup>a</sup>  
 Joiarib . . . . . 1727<sup>a</sup>  
 of Jehoiarib . . . . . 1580<sup>a</sup>  
 Join . . . . . 1727<sup>a</sup>  
 Jokdeam . . . . . 1727<sup>a</sup>  
 Jokim . . . . . 1727<sup>a</sup>  
 of Jehoiakim . . . . . 1579<sup>a</sup> (Genung)  
 of Joiakim . . . . . 1727<sup>a</sup>  
 Jokmeam . . . . . 1727<sup>a</sup>  
 Jokneam . . . . . 1727<sup>a</sup> (Ewing)  
 of Kishon . . . . . 1813<sup>a</sup> (Ewing)  
 Jokshan . . . . . 1727<sup>b</sup>  
 Joktan . . . . . 1727<sup>b</sup>  
 Joktheel . . . . . 1727<sup>b</sup>  
 of Sela . . . . . 2713<sup>b</sup> (Ewing)  
 Jona  
 of Jonah . . . . . 1727<sup>b</sup> (Sampey)  
 of Jonas . . . . . 1730<sup>a</sup> (Kerr)  
 Jonadab  
 of Jehonadab . . . . . 1580<sup>a</sup> (Roberts)  
 Jonah . . . . . 1727<sup>b</sup> (Sampey)  
 of Fish . . . . . 1115<sup>a</sup> (Day)  
 of Jonas . . . . . 1730<sup>a</sup> (Kerr)  
 Leading figure in Book  
 of Jonah . . . . . 1727<sup>b</sup>  
 Prophet in reign of  
 Jeroboam II . . . . . 1727<sup>b</sup>  
 Relation of prayer of  
 Jonah to Psalms . . . . . 1729<sup>b</sup>  
 of Ships and Boats . . . . . 2774<sup>a</sup> (Nicol)  
 Sign of repentance . . . . . 1728<sup>a</sup>  
 of Jesus Christ . . . . . 1644<sup>b</sup> (Orr)  
 Jonah, The Book of . . . . . 1728<sup>b</sup> (Sampey)  
 Aim of book . . . . . 1728<sup>b</sup>  
 Authorship and date . . . . . 1729<sup>a</sup>  
 Contents of book . . . . . 1728<sup>a</sup>  
 Did Jesus think it his-  
 tory? . . . . . 1728<sup>b</sup>  
 Is Mt 12 40 genuine? 1728<sup>b</sup>

- Jonah, The Book of—*continued*  
 Modern critical views. 1729<sup>a</sup>  
 of Shinar. . . . . 2773<sup>a</sup> (Pinches)  
 Unity. . . . . 1729<sup>b</sup>  
 Jonam (Jonan). . . . . 1729<sup>b</sup>  
 Jonas (Apoc). . . . . 1729<sup>b</sup>  
 Jonas. . . . . 1730<sup>a</sup> (Kerr)  
 cf Jonah. . . . . 1727<sup>b</sup> (Sampey)  
 Jonath Elem Rehokim. 1730<sup>a</sup>  
 cf Psalms, Book of. . . 2487<sup>a</sup> (Sampey)  
 cf Song. . . . . 2830<sup>b</sup> (Millar)  
 Jonathan (general). . . . 1730<sup>a</sup> (Roberts); 792<sup>b</sup>  
 (Weir)  
 Jonathan (son of Saul). 1730<sup>b</sup> (Weir)  
 Character. . . . . 1731<sup>a</sup>  
 Commanding at Mich-  
 mash. . . . . 1730<sup>b</sup>  
 Death at Gilboa. . . . 1731<sup>a</sup>  
 Filial piety. . . . . 1731<sup>b</sup>  
 Friendship for David. 1731<sup>a</sup>  
 cf Jahzeiah. . . . . 1559<sup>a</sup> (Roberts)  
 cf Jashen. . . . . 1570<sup>b</sup> (Roberts)  
 cf Jehohanan. . . . . 1577<sup>b</sup> (Roberts)  
 cf Jehonadab. . . . . 1580<sup>a</sup> (Roberts)  
 cf Jehonathan. . . . . 1580<sup>b</sup>  
 Leadership. . . . . 1731<sup>a</sup>  
 Rout of Philistine gar-  
 rison. . . . . 1731<sup>a</sup>  
 cf Saul. . . . . 2698<sup>a</sup> (Weir)  
 Jonathan (Maccabaeus)  
 cf Maccabaeus. . . . . 1947<sup>a</sup> (Hutchison); 284<sup>b</sup>  
 (Dosker)  
 Jonathan, Targum of  
 cf Targum. . . . . 2912<sup>b</sup> (J. E. H. Thomson)  
 Jonathas. . . . . 1731<sup>b</sup>  
 cf Jathan. . . . . 1571<sup>b</sup>  
 Joppa. . . . . 1731<sup>b</sup> (Ewing)  
 Biblical references. . . 1732<sup>a</sup>  
 Maccabean times. . . . 1732<sup>a</sup>  
 Modern Jaffa. . . . . 1732<sup>b</sup>  
 Non-Hebrew references. 1731<sup>b</sup>  
 Roman and Crusader  
 times. . . . . 1732<sup>a</sup>  
 Sea, the Great. . . . . 2707<sup>b</sup> (Ewing)  
 cf Ships and Boats. . . 2774<sup>a</sup> (Nicol)  
 Jorah. . . . . 1732<sup>b</sup>  
 cf Hariph. . . . . 1339<sup>b</sup>  
 Jorai. . . . . 1732<sup>b</sup>  
 Joram. . . . . 1732<sup>b</sup>; 1580<sup>b</sup> (Mosiman)  
 cf Hadoram. . . . . 1316<sup>a</sup> (Hovey)  
 cf Jehoram. . . . . 1580<sup>b</sup> (Mosiman)  
 cf Jozabad. . . . . 1755<sup>b</sup>  
 Jordan. . . . . 1732<sup>b</sup> (Wright)  
 cf Arabah. . . . . 211<sup>b</sup> (Wright)  
 Bridges. . . . . 1734<sup>b</sup>  
 cf Dead Sea. . . . . 801<sup>a</sup> (Wright)  
 Et Ghor. . . . . 1733<sup>b</sup>  
 Fords of. . . . . 1734<sup>a</sup>  
 cf Ford. . . . . 1127<sup>a</sup> (Day)  
 cf Joshua (son of Nun). 1745<sup>a</sup> (Geden)  
 Lake Huleh. . . . . 1733<sup>a</sup>  
 Lower plain of. . . . . 1734<sup>a</sup>
- Jordan—*continued*  
 cf Palestine. . . . . 2212<sup>a</sup> (Conder)  
 Sea of Galilee. . . . . 1733<sup>a</sup>  
 Sources. . . . . 1732<sup>b</sup>  
 Yarmak, the. . . . . 1733<sup>a</sup>  
 Jordan, Plains of. . . . . 807<sup>b</sup> (Wright)  
 Jordan Valley. . . . . 1735<sup>a</sup> (Wright)  
 Aqueducts in. . . . . 1735<sup>b</sup>  
 cf Arabah. . . . . 211<sup>b</sup> (Wright)  
 Climate, fauna and  
 flora. . . . . 1736<sup>a</sup>  
 cf Dead Sea. . . . . 801<sup>a</sup> (Wright)  
 Descriptions of. . . . . 1735<sup>b</sup>  
 Divisions of. . . . . 1735<sup>b</sup>  
 cf Geology of Pales-  
 tine. . . . . 1215<sup>b</sup> (Day)  
 cf Jericho. . . . . 1592<sup>a</sup> (Wright)  
 cf Lebanon. . . . . 1864<sup>a</sup> (Wright)  
 cf Merom, Waters of. . 2037<sup>a</sup> (Wright)  
 Physical features. . . . 1735<sup>a</sup>  
 Joribus. . . . . 1736<sup>b</sup>  
 cf Jarib. . . . . 1570<sup>a</sup>  
 Jorim. . . . . 1736<sup>b</sup>  
 Jorkeam. . . . . 1736<sup>b</sup>  
 Josabad  
 cf Jozabad. . . . . 1755<sup>b</sup>  
 Josabdus. . . . . 1736<sup>b</sup>  
 Josaphat. . . . . 1736<sup>b</sup>  
 cf Jehoshaphat. . . . . 1582<sup>a</sup> (Mosiman)  
 Josaphias. . . . . 1736<sup>b</sup>  
 Jose. . . . . 1736<sup>b</sup>  
 Josech. . . . . 1736<sup>b</sup>  
 Josedech. . . . . 1736<sup>b</sup>  
 cf Jehozadak. . . . . 1584<sup>b</sup>  
 Josedek. . . . . 1736<sup>b</sup>  
 Joseph (general). . . . . 1736<sup>b</sup> (S. F. Hunter)  
 cf Barnabas. . . . . 405<sup>b</sup> (Jacobs)  
 cf Joses. . . . . 1743<sup>a</sup>  
 Joseph (son of Jacob). . 1737<sup>a</sup> (Kyle)  
 In Canaan. . . . . 1738<sup>b</sup>  
 cf Pentateuch. . . . . 2298<sup>a</sup> (Wiener)  
 Character of. . . . . 1739<sup>b</sup>  
 Critical views. . . . . 1737<sup>a</sup>  
 Dreams interpreted. . . 1739<sup>a</sup>  
 Exaltation of. . . . . 1739<sup>b</sup>  
 Famines in Egypt. . . . 1739<sup>b</sup>  
 Ideal patriarch, the. . . 1740<sup>a</sup>  
 Is story composite? . . 1737<sup>a</sup>  
 cf Jacob. . . . . 1551<sup>b</sup> (Boyd)  
 Jacob's favoritism. . . . 1738<sup>b</sup>  
 Literary questions. . . . 1737<sup>a</sup>  
 Name, the. . . . . 1737<sup>a</sup>  
 Sold into slavery. . . . . 1738<sup>b</sup>  
 Story of. . . . . 1738<sup>a</sup>  
 "Tale of Two Broth-  
 ers". . . . . 1737<sup>b</sup>  
 Tomb of  
 cf Jacob's Well. . . . . 1556<sup>a</sup> (Ewing)  
 cf Zaphenath-paneah. . 3132<sup>a</sup>  
 Joseph of Arimathaea. . 1741<sup>b</sup> (Kerr)  
 cf Joseph. . . . . 1736<sup>b</sup> (S. F. Hunter)  
 cf Philip. . . . . 2368<sup>a</sup> (Kerr)

- Joseph Barnabas . . . . . 405<sup>b</sup> (Jacobs)  
 Joseph Barsabbas . . . . . 1740<sup>a</sup> (Kerr)  
   of Justus . . . . . 1788<sup>b</sup> (S. F. Hunter)  
 Joseph the Carpenter,  
   Apocryphal Gospel of  
   of Apocryphal Gospels . . . . . 199<sup>a</sup> (Hutchison)  
 Joseph, Husband of Mary 1740<sup>b</sup> (Kerr)  
   After the nativity . . . . . 1740<sup>b</sup>  
   Before the nativity . . . . . 1740<sup>b</sup>  
   Character of . . . . . 1741<sup>a</sup>  
   Extra-canonical refer-  
   ences . . . . . 1741<sup>a</sup>  
   of James, Brother of  
     the Lord . . . . . 1561<sup>a</sup> (Kerr)  
   of Jesus Christ . . . . . 1632<sup>a</sup> (Orr)  
   of Joseph . . . . . 1736<sup>b</sup> (S. F. Hunter)  
   Sequence of events . . . . . 1741<sup>a</sup>  
 Joseph, Prayer of . . . . . 1741<sup>b</sup> (Easton)  
 Joseph's Dream  
   of Astronomy . . . . . 300<sup>b</sup> (Maunder)  
   of Joseph . . . . . 1737<sup>a</sup> (Kyle)  
 Josephus (Apoc) . . . . . 1742<sup>a</sup>  
 Josephus Flavius . . . . . 1742<sup>a</sup> (Wenley); 999<sup>a</sup>  
   (J. E. H. Thomson)  
   Apologetic purpose . . . . . 1742<sup>b</sup>  
   Ascetic in youth . . . . . 1742<sup>a</sup>  
   Description of Jerusa-  
   lem . . . . . 1600<sup>a</sup> (Masterman)  
   of Essenes . . . . . 997<sup>b</sup> (J. E. H. Thomson)  
   Favored by Romans . . . . . 1742<sup>a</sup>  
   Governor of Galilee . . . . . 1742<sup>a</sup>  
   Jewish war, the . . . . . 1742<sup>a</sup>  
   of Pharisees . . . . . 2362<sup>b</sup> (J. E. H. Thomson)  
   of Sadducees . . . . . 2659<sup>a</sup> (J. E. H. Thomson)  
   of Triumph . . . . . 3022<sup>b</sup> (A. W. Evans)  
   Visit to Rome . . . . . 1742<sup>a</sup>  
   Writings of . . . . . 1742<sup>b</sup>  
   of Zealots . . . . . 3133<sup>b</sup> (Heidel)  
 Joses . . . . . 1743<sup>a</sup>  
   of Brethren of the Lord 518<sup>b</sup> (Jacobs)  
   of Joseph . . . . . 1736<sup>b</sup> (S. F. Hunter)  
 Joshah . . . . . 1743<sup>a</sup>  
   of Joshaviah . . . . . 1743<sup>a</sup>  
 Joshaphat . . . . . 1743<sup>a</sup>  
   of Jehoshaphat . . . . . 1581<sup>b</sup> (Roberts)  
 Joshaviah . . . . . 1743<sup>a</sup>  
   of Joshah . . . . . 1743<sup>a</sup>  
 Joshbekashah . . . . . 1743<sup>a</sup>  
   of Romanti-ezer . . . . . 2597<sup>b</sup>  
 Josheb-basshebeth . . . . . 1743<sup>a</sup>  
 Joshibiah . . . . . 1743<sup>a</sup>  
 Joshua (general) . . . . . 1743<sup>a</sup>  
 Joshua (son of Nun) . . . . . 1743<sup>a</sup> (Geden); 255<sup>a</sup>  
   (Nicol); 446<sup>b</sup> (Maunder)  
   Allotment of territory  
     to tribes . . . . . 1746<sup>b</sup>  
   of Beth-horon, Battle  
     of . . . . . 446<sup>b</sup> (Maunder)  
   Capture of Jericho . . . . . 1745<sup>b</sup>  
   Character of . . . . . 1747<sup>b</sup>  
   Conquest of Ai and  
     Bethel . . . . . 1745<sup>b</sup>  
 Joshua (son of Nun)—*continued*  
   Conquests in Canaan . . . . . 1746<sup>b</sup>  
   Crossing of Jordan . . . . . 1745<sup>a</sup>  
   Crown for . . . . . 1748<sup>b</sup>  
   Desert wanderings . . . . . 1744<sup>b</sup>  
   of Deuteronomic law . . . . . 838<sup>a</sup> (Robinson)  
   of Gibeon . . . . . 1225<sup>b</sup> (Ewing)  
   Gibeonite stratagem . . . . . 1746<sup>a</sup>  
   of Jehoshua . . . . . 1583<sup>b</sup>  
   of Jeshua . . . . . 1622<sup>b</sup> (Roberts)  
   of Jordan . . . . . 1732<sup>b</sup> (Wright)  
   of Joshua, Book of . . . . . 1749<sup>a</sup> (Geden)  
   Last days and death . . . . . 1747<sup>a</sup>  
   Leadership of . . . . . 1744<sup>b</sup>  
   Life of . . . . . 1743<sup>b</sup>  
   of Moses . . . . . 2088<sup>a</sup> (Kyle)  
   Name, the . . . . . 1743<sup>b</sup>  
   Natural staying of  
     Jordan . . . . . 1745<sup>a</sup>  
   of Oshea . . . . . 2202<sup>a</sup>  
   Parallels with Moses . . . . . 1747<sup>a</sup>  
   Scouts sent to Jericho . . . . . 1745<sup>a</sup>  
   Spy . . . . . 1744<sup>a</sup>  
   With Moses at Rephi-  
     dim . . . . . 1743<sup>b</sup>  
   With Moses at Sinai . . . . . 1744<sup>a</sup>  
 Joshua (son of Jehoza-  
 dak) . . . . . 1748<sup>a</sup> (Roberts)  
   Companion of Zerub-  
     babel . . . . . 1748<sup>a</sup>  
   of Haggai . . . . . 1317<sup>a</sup> (Robinson)  
   Trial of . . . . . 1748<sup>a</sup>  
   of Zechariah . . . . . 3135<sup>b</sup> (Easton)  
   of Zerubbabel . . . . . 3147<sup>b</sup> (R. D. Wilson)  
 Joshua, Book of . . . . . 1749<sup>a</sup> (Geden)  
   Allotments to tribes . . . . . 1749<sup>b</sup>  
   Ancient versions . . . . . 1751<sup>a</sup>  
   Authorship . . . . . 1749<sup>a</sup>  
   Canonicity of . . . . . 1751<sup>a</sup>  
   Chronology of . . . . . 1750<sup>a</sup>  
   Compilation of . . . . . 1749<sup>b</sup>  
   Conquest of Palestine . . . . . 1749<sup>a</sup>  
   Contents . . . . . 1749<sup>a</sup>  
   Gaps in history . . . . . 1750<sup>b</sup>  
   of Hexateuch . . . . . 1385<sup>a</sup> (Wiener)  
   of Joshua (son of Nun) . . . . . 1743<sup>a</sup> (Geden)  
   of Palestine . . . . . 2212<sup>a</sup> (Conder)  
   Purpose and teaching . . . . . 1751<sup>b</sup>  
   Relation to Judges . . . . . 1750<sup>b</sup>  
   Sources . . . . . 1750<sup>a</sup>  
 Josiah . . . . . 1751<sup>b</sup> (Genung)  
   of Amou . . . . . 118<sup>b</sup> (Genung)  
   Centralization of wor-  
     ship . . . . . 1753<sup>a</sup>  
   Conditions at corona-  
     tion . . . . . 1752<sup>a</sup>  
   Death at Megiddo . . . . . 1753<sup>b</sup>  
   of Deuteronomy . . . . . 835<sup>b</sup> (Robinson)  
   Finding of the law  
     book . . . . . 1752<sup>b</sup>  
   Great reformation . . . . . 1753<sup>a</sup>  
   of Hen (person) . . . . . 1374<sup>b</sup>

Josiah—*continued*

- cf Hezekiah . . . . . 1388<sup>a</sup> (Genung)
- cf Israel, History of . . . 1524<sup>a</sup> (Orelli)
- cf Jehoahaz . . . . . 1575<sup>b</sup> (Genung)
- cf Jehoiakim . . . . . 1579<sup>a</sup> (Genung)
- cf Jeremiah . . . . . 1588<sup>a</sup> (Orelli)
- cf Job, Book of . . . . . 1679<sup>b</sup> (Genung)
- Later date of Deuteronomy . . . . . 1752<sup>b</sup>
- cf Pharaoh-necoh . . . . . 2360<sup>a</sup> (Nicol)
- Sources for . . . . . 1752<sup>a</sup>
- cf Writing . . . . . 3114<sup>a</sup> (Richardson)
- Josias . . . . . 1753<sup>b</sup>
- cf Jesias . . . . . 1623<sup>a</sup>
- Josibiah
  - cf Joshibiah . . . . . 1743<sup>a</sup>
- Josiphiah . . . . . 1753<sup>b</sup>
- Jot . . . . . 1753<sup>b</sup> (Easton)
  - cf Jod . . . . . 1688<sup>a</sup>
  - cf Tittle . . . . . 2988<sup>b</sup>
- Jotapata
  - cf Jotbathah . . . . . 1754<sup>a</sup>
- Jotbah . . . . . 1754<sup>a</sup>
  - cf Jotbathah . . . . . 1754<sup>a</sup>
- Jotbathah . . . . . 1754<sup>a</sup>
  - cf Wanderings of Israel . . . . . 3064<sup>a</sup> (Conder)
- Jotham . . . . . 1754<sup>a</sup> (Easton)
  - Fable of . . . . . 1754<sup>a</sup>
- Jotham (king of Judah) . 1754<sup>a</sup> (Caldecott)
  - Building operations . . . 1754<sup>b</sup>
  - Condition of Judah . . . 1754<sup>b</sup>
  - Co-regent with Uzziah . 1754<sup>a</sup>
  - Syrian league against . . 1754<sup>b</sup>
  - War with Ammonites . 1754<sup>b</sup>
- Journey
  - cf Day's Journey . . . . . 799<sup>b</sup> (Porter)
  - cf Sabbath Day's Journey . . . . . 2634<sup>a</sup> (Porter)
- Joy . . . . . 1755<sup>a</sup> (Edwards)
  - Terms for . . . . . 1755<sup>a</sup>
  - Use in NT . . . . . 1755<sup>b</sup>
  - Use in OT . . . . . 1755<sup>a</sup>
- Jozabad . . . . . 1755<sup>b</sup>
  - cf Joram . . . . . 1732<sup>b</sup>
- Jozabdu . . . . . 1756<sup>a</sup>
- Jozacar . . . . . 1756<sup>a</sup>
- Jozadak
  - cf Jehozadak . . . . . 1584<sup>b</sup>
- Jubal . . . . . 1756<sup>a</sup>
  - cf Jabal . . . . . 1546<sup>b</sup> (Roberts)
- Jubilee, Cycle of the
  - cf Astronomy, Lunar Cycle . . . . . 300<sup>b</sup> (Maunder)
- Jubilee Year . . . . . 1756<sup>a</sup> (Baur)
  - Character of . . . . . 1756<sup>a</sup>
  - Liberty of . . . . . 1756<sup>a</sup>
  - Limitations of . . . . . 1756<sup>b</sup>
  - cf Release . . . . . 2556<sup>b</sup>
  - Restitution of property . . . . . 1756<sup>b</sup>

Jubilee Year—*continued*

- cf Sabbaths of Years . . . 2634<sup>b</sup>
- cf Sabbatical Year . . . . 2634<sup>b</sup> (Baur)
- Was it really observed? 1757<sup>a</sup>
- Jubilees, Book of . . . . . 173<sup>a</sup> (J. E. H. Thomson)
- cf Seventy Weeks . . . . . 2744<sup>a</sup> (Orr)
- Jucal
  - cf Jehucal . . . . . 1586<sup>a</sup>
- Juchabar (Ibhar) . . . . . 1446<sup>a</sup>
- Juda . . . . . 1757<sup>a</sup>
  - cf Joda . . . . . 1688<sup>a</sup>
  - cf Judas . . . . . 1765<sup>a</sup> (S. F. Hunter)
  - cf Juttah . . . . . 1788<sup>b</sup> (Masterman)
- Judaea . . . . . 1757<sup>a</sup> (Masterman)
  - Crusader times . . . . . 1757<sup>b</sup>
  - cf Jeshimon . . . . . 1622<sup>a</sup> (Masterman)
  - cf Jewry . . . . . 1675<sup>b</sup>
  - cf Judah . . . . . 1758<sup>a</sup> (Ewing)
  - cf Judah, Territory of . 1763<sup>a</sup> (Masterman)
  - Limits . . . . . 1757<sup>a</sup>
  - cf Negeb . . . . . 2130<sup>a</sup> (Masterman)
  - Origin of name . . . . . 1757<sup>a</sup>
- Judaea, Wilderness of . . 1757<sup>b</sup>
- Judah (general) . . . . . 1757<sup>b</sup> (S. F. Hunter)
- Judah (patriarch) . . . . . 1758<sup>a</sup> (Ewing)
  - cf Jacob . . . . . 1549<sup>a</sup> (Boyd)
  - Son of Jacob . . . . . 1758<sup>a</sup>
  - cf Tamar (person) . . . . 2907<sup>b</sup> (Orr)
  - Tribe of . . . . . 1758<sup>a</sup>
- Judah (tribe)
  - cf Extent of tribe . . . . . 1758<sup>a</sup> (Ewing)
  - cf Hill, Hill Country . . 1392<sup>a</sup> (Masterman)
  - cf Judaea . . . . . 1757<sup>a</sup> (Masterman)
  - cf Judah, Territory of . 1763<sup>a</sup> (Masterman)
  - cf Numbers, Book of . . . 2163<sup>a</sup> (Whitelaw)
- Judah, Kingdom of . . . . . 1758<sup>a</sup> (Weir)
  - Before the monarchy . . . 1758<sup>b</sup>
  - Early rulers . . . . . 1759<sup>a</sup>
  - Entrance into Canaan . . . . . 1758<sup>b</sup>
  - Hebrew tribes . . . . . 1758<sup>b</sup>
  - Semites and Canaanites . . . . . 1758<sup>b</sup>
- cf David . . . . . 790<sup>b</sup> (Weir)
- Dual monarchy . . . . . 1760<sup>a</sup>
  - Age of Jehoshaphat . 1760<sup>a</sup>
  - Athaliah's reign . . . . . 1760<sup>b</sup>
  - Civil wars . . . . . 1760<sup>a</sup>
  - Contrasts between Israel and Judah . 1760<sup>a</sup>
  - Influence of Isaiah . . 1761<sup>a</sup>
  - Reign of Uzziah . . . . . 1761<sup>a</sup>
  - Revived fortunes . . . . . 1760<sup>b</sup>
- First three kings . . . . . 1759<sup>a</sup>
  - Kingdom of David . . . 1759<sup>b</sup>
  - Solomon and the disruption . . . . . 1759<sup>b</sup>
- cf Israel, Kingdom of . 1528<sup>b</sup> (Weir)
- Period of decline . . . . . 1761<sup>b</sup>
  - Age of Hezekiah . . . . . 1761<sup>b</sup>
  - Age of Jeremiah . . . . . 1762<sup>a</sup>
  - Fall of Assyria . . . . . 1762<sup>a</sup>



- Judah, Kingdom of—*continued*  
 Period of decline—*continued*  
 Fall of Judah . . . . . 1762<sup>b</sup>  
 Foreign influences . . . 1761<sup>b</sup>  
 Reaction under Manasseh . . . . . 1761<sup>b</sup>  
 Reformation of Josiah . . . . . 1762<sup>a</sup>  
 of Saul . . . . . 2697<sup>b</sup> (Weir)  
 Judah, Territory of . . . . . 1763<sup>a</sup> (Masterman)  
 of Beth-horon . . . . . 446<sup>a</sup> (Masterman)  
 of Beth-zur . . . . . 454<sup>a</sup> (Masterman)  
 of Botany . . . . . 505<sup>a</sup> (Masterman)  
 Boundaries of Kingdom of Judah . . . . . 1763<sup>a</sup>; 1764<sup>b</sup>  
 Chief roads . . . . . 1763<sup>b</sup>  
 Divisions . . . . . 1763<sup>a</sup>  
 Hill country . . . . . 1763<sup>b</sup>  
 of Jericho . . . . . 1592<sup>a</sup> (Wright)  
 of Jeshimon . . . . . 1622<sup>a</sup> (Masterman)  
 of Judaea . . . . . 1757<sup>a</sup> (Masterman)  
 of Judah . . . . . 1758<sup>a</sup> (Ewing)  
 Products . . . . . 1764<sup>a</sup>  
 Shephelah . . . . . 1763<sup>a</sup>  
 Size . . . . . 1764<sup>b</sup>  
 Tribe and its land . . . 1764<sup>a</sup>  
 Judah at the Jordan . . . 1765<sup>a</sup>  
 Judaism  
 In Arabia . . . . . 219<sup>a</sup> (Weir)  
 of Israel, Religion of . . 1530<sup>b</sup> (Orelli)  
 of Paul . . . . . 2276<sup>a</sup> (A. T. Robertson)  
 Rise and development . . 574<sup>b</sup> (Nicol)  
 Judas (Apoc) . . . . . 1765<sup>a</sup> (Hutchison)  
 of Maccabaeus . . . . . 1946<sup>a</sup> (Hutchison)  
 Judas Barsabbas . . . . . 1765<sup>a</sup> (S. F. Hunter)  
 of Judas, Juda . . . . . 1765<sup>a</sup> (S. F. Hunter)  
 Judas of Damascus  
 of Judas, Juda . . . . . 1765<sup>a</sup> (S. F. Hunter)  
 Judas of Galilee . . . . . 1767<sup>a</sup> (Orr)  
 of Judas, Juda . . . . . 1765<sup>a</sup> (S. F. Hunter)  
 of Quirinius . . . . . 645<sup>a</sup> (Armstrong)  
 Judas Iscariot . . . . . 1765<sup>b</sup> (Kerr)  
 Attitude of Fourth Gospel toward . . . 1765<sup>b</sup>  
 Betrayal of Jesus . . . . . 1766<sup>a</sup>  
 Call by Jesus . . . . . 1765<sup>b</sup>  
 Death of . . . . . 1766<sup>a</sup>  
 Foreordained . . . . . 1766<sup>b</sup>  
 Gradual degeneration . . 1766<sup>b</sup>  
 Home . . . . . 1765<sup>b</sup>  
 Motives of . . . . . 1766<sup>b</sup>  
 of Simon the Cananaean . . . . . 2797<sup>b</sup> (Kerr)  
 Judas Iscariot, Gospel of 1767<sup>a</sup> (Orr)  
 Judas (not Iscariot) . . . 1765<sup>a</sup>  
 of Judas of James . . . . 1767<sup>b</sup> (Kerr)  
 of Lebbaeus . . . . . 1864<sup>a</sup>  
 of Thaddaeus . . . . . 2964<sup>a</sup> (Kerr)  
 Judas of James . . . . . 1767<sup>b</sup> (Kerr)  
 of Jude . . . . . 1767<sup>b</sup>  
 of Judas, Juda . . . . . 1765<sup>a</sup> (S. F. Hunter)  
 of Thaddaeus . . . . . 2964<sup>a</sup> (Kerr)  
 Judas, Juda . . . . . 1765<sup>a</sup> (S. F. Hunter)  
 of Judas Barsabbas . . . 1765<sup>a</sup> (S. F. Hunter)  
 of Judas Iscariot . . . . 1765<sup>b</sup> (Kerr)  
 of Judas of James . . . . 1767<sup>b</sup> (Kerr)  
 of Lebbaeus . . . . . 1864<sup>a</sup>  
 of Thaddaeus . . . . . 2964<sup>a</sup> (Kerr)  
 Judas, the Lord's Brother  
 of Jude . . . . . 1767<sup>b</sup>  
 Judas Maccabaeus . . . . 283<sup>b</sup> (Dosker); 457<sup>a</sup> (Dosker)  
 of Maccabaeus . . . . . 1947<sup>a</sup> (Hutchison)  
 of Pharisees . . . . . 2361<sup>a</sup> (J. E. H. Thomson)  
 Juddah  
 of Juttah . . . . . 1788<sup>b</sup> (Masterman)  
 Jude . . . . . 1767<sup>b</sup>  
 of Judas, Juda . . . . . 1765<sup>a</sup> (S. F. Hunter)  
 of Judas of James . . . . 1767<sup>b</sup> (Kerr)  
 of Peter, Second Epistle  
 of . . . . . 2356<sup>b</sup> (Moorehead)  
 Jude, Epistle of . . . . . 1767<sup>b</sup> (Moorehead)  
 Advice to faithful . . . . 1770<sup>a</sup>  
 Brother of Jesus and James? . . . . . 1767<sup>b</sup>  
 Characters denounced . . 1768<sup>b</sup>; 1771<sup>a</sup>  
 Early testimony . . . . . 1768<sup>a</sup>  
 Libertinism . . . . . 1771<sup>b</sup>  
 Occasion of composition . . . . . 1768<sup>b</sup>  
 Parallels with 2 Peter . . 1769<sup>b</sup>  
 People addressed . . . . . 1768<sup>b</sup>  
 Position in canon . . . . 1768<sup>a</sup>  
 Priority of 2 Peter . . . . 1770<sup>b</sup>  
 Question of date . . . . . 1771<sup>a</sup>  
 References to OT and extra-canonical literature . . . . . 1770<sup>a</sup>  
 Relation to 2 Peter . . . . 1769<sup>a</sup>  
 Writer of . . . . . 1767<sup>b</sup>  
 Judea . . . . . 1771<sup>b</sup>  
 of Judaea . . . . . 1757<sup>a</sup> (Masterman)  
 Judge . . . . . 1771<sup>b</sup> (Levertoff)  
 of Judgment Seat . . . . . 1778<sup>a</sup>  
 of Oath . . . . . 2172<sup>b</sup> (Levertoff)  
 of Priests and Levites . . 2452<sup>b</sup> (Wiener)  
 Judges, Book of . . . . . 1772<sup>a</sup> (Geden)  
 Artificial time and place . . . . . 1774<sup>a</sup>  
 Authorship . . . . . 1774<sup>a</sup>  
 Chronology of . . . . . 1773<sup>b</sup>  
 Contents . . . . . 1772<sup>b</sup>  
 Early versions . . . . . 1775<sup>a</sup>  
 Gideon . . . . . 1773<sup>a</sup>  
 Introductions to . . . . . 1772<sup>b</sup>  
 of Israel, History of the  
 People . . . . . 1518<sup>a</sup> (Orelli)  
 of Jephthah . . . . . 1587<sup>a</sup> (Schenk)  
 of Joshua, Book of . . . . 1750<sup>b</sup> (Geden)  
 of Judah, Kingdom of . . 1759<sup>a</sup> (Weir)  
 of Judges, Period of . . . 1775<sup>b</sup> (Knudson)  
 of King and Kingdom . . 1800<sup>a</sup> (Press)  
 Micah of Ephraim . . . . 1773<sup>b</sup>  
 of Micah . . . . . 2045<sup>b</sup> (Lees)

- Judges, Book of—*continued*  
 Position in canon . . . . . 1772<sup>b</sup>  
 Purpose and value . . . . . 1775<sup>a</sup>  
 Relation to Hexateuch 1774<sup>b</sup>  
 of Samson, History of . 2675<sup>a</sup> (Robinson)  
 Sources . . . . . 1774<sup>b</sup>  
 Title . . . . . 1772<sup>a</sup>  
 War with Benjamin . . . . . 1773<sup>b</sup>  
 Work of the Judges . . . . . 1772<sup>b</sup>
- Judges, Period of . . . . . 1775<sup>b</sup> (Knudson)  
 Chronology . . . . . 1775<sup>b</sup>  
 Invasions . . . . . 1776<sup>b</sup>  
 of Judges, Book of . . . . . 1772<sup>a</sup> (Geden)  
 Need of government . . . . . 1776<sup>b</sup>  
 Political situation . . . . . 1776<sup>a</sup>  
 Relation to Canaanites 1776<sup>a</sup>  
 Religious conditions . . . . . 1776<sup>b</sup>  
 Sources . . . . . 1775<sup>b</sup>  
 Theological interpretation . . . . . 1777<sup>a</sup>  
 Tribal leaders . . . . . 1776<sup>b</sup>  
 Tribal struggles . . . . . 1776<sup>a</sup>
- Judging, Judgment . . . . . 1777<sup>a</sup> (Jacobs)  
 of Johannine Theology . . . . . 1705<sup>b</sup> (Law)  
 of Retribution . . . . . 2570<sup>a</sup> (M'Caig)
- Judgment, Day of  
 of Judgment, Last . . . . . 1777<sup>b</sup> (Easton)
- Judgment Hall . . . . . 1777<sup>b</sup> (Rutherford)  
 of Palace . . . . . 2208<sup>a</sup> (Orr)  
 of Praetorium . . . . . 2428<sup>b</sup> (Masterman)
- Judgment, Last . . . . . 1777<sup>b</sup> (Easton)  
 "Day of the Lord" . . . . . 1777<sup>b</sup>  
 of Eschatology of the NT . . . . . 979<sup>b</sup> (Vos)  
 In extra-canonical literature . . . . . 1778<sup>a</sup>  
 Nature of the doctrine . . . . . 1777<sup>b</sup>  
 of Parousia . . . . . 2249<sup>a</sup> (Easton)  
 of Resurrection . . . . . 2564<sup>b</sup> (Easton)
- Judgment Seat . . . . . 1778<sup>a</sup>  
 of Gabbatha . . . . . 1150<sup>b</sup> (Masterman)  
 of Judge . . . . . 1771<sup>b</sup> (Levertoff)
- Judicial Blindness . . . . . 488<sup>a</sup> (T. Lewis)
- Judicial Courts . . . . . 725<sup>b</sup> (Hirsch)
- Judicial Hardening  
 of Harden . . . . . 1338<sup>a</sup> (W. L. Walker)
- Judith . . . . . 1778<sup>a</sup>  
 of Palestine . . . . . 2220<sup>a</sup> (Conder)
- Judith, Book of . . . . . 1778<sup>b</sup> (T. W. Davies)  
 of Apocrypha . . . . . 178<sup>b</sup> (T. W. Davies)  
 Contents . . . . . 1778<sup>b</sup>  
 Date of . . . . . 1779<sup>b</sup>  
 Dates suggested . . . . . 1789<sup>b</sup>  
 Fact or fiction? . . . . . 1779<sup>a</sup>  
 Historical errors of . . . . . 1779<sup>a</sup>  
 Name . . . . . 1778<sup>b</sup>  
 Original language . . . . . 1780<sup>a</sup>  
 Place in Hebrew literature . . . . . 1778<sup>b</sup>  
 Story of Judith . . . . . 1779<sup>a</sup>  
 Versions . . . . . 1780<sup>b</sup>
- Juel . . . . . 1780<sup>b</sup>
- Jugglery . . . . . 1780<sup>b</sup>
- Juice . . . . . 1780<sup>b</sup>
- Julia . . . . . 1780<sup>b</sup>
- Julius . . . . . 1780<sup>b</sup>  
 of Army, Roman . . . . . 257<sup>a</sup> (Allen)  
 of Band, Augustan . . . . . 382<sup>b</sup> (Nicol)  
 of Roman Empire . . . . . 2598<sup>b</sup> (Angus)
- Jumping  
 of Games . . . . . 1168<sup>b</sup> (Smith)
- Junias . . . . . 1781<sup>a</sup> (S. F. Hunter)  
 of Herodion . . . . . 1384<sup>a</sup>
- Juniper . . . . . 1781<sup>a</sup> (Masterman)  
 of Salt-wort . . . . . 2664<sup>b</sup> (Masterman)
- Jupiter . . . . . 1781<sup>a</sup> (Easton)  
 of Abomination of Desolation . . . . . 16<sup>a</sup> (Hirsch)  
 of Olympius . . . . . 2188<sup>b</sup>  
 of Zeus . . . . . 3148<sup>a</sup> (Angus)
- Jupiter and Mercury  
 of Astrology . . . . . 295<sup>b</sup> (Maunder)  
 of Jupiter . . . . . 1781<sup>a</sup> (Easton)  
 of Mercury . . . . . 2035<sup>a</sup> (M. O. Evans)
- Jurisdiction . . . . . 1781<sup>b</sup>
- Jushab-hesed . . . . . 1781<sup>b</sup>  
 of Shear-jashub . . . . . 2752<sup>b</sup>
- Justice . . . . . 1781<sup>b</sup> (Rall)  
 Divine . . . . . 1782<sup>a</sup>  
 Human . . . . . 1781<sup>b</sup>  
 of Righteousness . . . . . 2591<sup>a</sup> (McConnell)  
 of Sanctification . . . . . 2682<sup>b</sup> (Rall)
- Justification . . . . . 1782<sup>b</sup> (Faulkner)  
 of Faith . . . . . 1087<sup>b</sup> (Dunelm)  
 of Grace . . . . . 1290<sup>a</sup> (Easton)  
 of Imputation . . . . . 1462<sup>a</sup> (Hodge)  
 Later development . . . . . 1786<sup>b</sup>  
 Church fathers . . . . . 1786<sup>b</sup>  
 Council of Trent . . . . . 1787<sup>a</sup>  
 Luther . . . . . 1787<sup>a</sup>  
 Modern meaning . . . . . 1787<sup>b</sup>  
 Schleiermacher and Ritschl . . . . . 1787<sup>b</sup>  
 Venture of faith . . . . . 1788<sup>a</sup>
- Old Testament . . . . . 1786<sup>a</sup>  
 Instances of . . . . . 1786<sup>a</sup>
- Other NT writings . . . . . 1784<sup>b</sup>  
 James . . . . . 1785<sup>b</sup>  
 of James, Epistle of . 1562<sup>a</sup> (Hayes)  
 Johannine writings . . . . . 1785<sup>b</sup>  
 1 Peter and Hebrews 1785<sup>b</sup>  
 Synoptic Gospels . . . . . 1785<sup>a</sup>
- In Paul's writings . . . . . 1782<sup>b</sup>  
 Baptism eliminated . 1784<sup>a</sup>  
 Death and resurrection of Christ . . . . . 1783<sup>a</sup>  
 Factors in justification . . . . . 1784<sup>a</sup>  
 Faith, not works . . . . . 1783<sup>b</sup>  
 Individual in meaning . . . . . 1784<sup>b</sup>  
 Paul's experience . . . . . 1783<sup>a</sup>  
 of Paul, Theology of . 2291<sup>a</sup> (Easton)

- Justification—*continued*  
 In Paul's writings—*continued*  
 Perfection of Divine  
 law . . . . . 1782<sup>b</sup>  
 Sin universal . . . . . 1782<sup>b</sup>  
 Work of Christ . . . . . 1783<sup>a</sup>  
 cf Romans, Epistle to . . . 2616<sup>b</sup> (Dunelm)  
 cf Sacrifice, NT . . . . . 2654<sup>a</sup> (Williams)  
 cf Salvation . . . . . 2669<sup>b</sup> (Easton)  
 cf Work . . . . . 3105<sup>b</sup> (W. L. Walker)
- Justin Martyr  
 cf Literature, Sub-  
 apos . . . . . 1903<sup>b</sup> (Cowan)  
 cf Lord's Supper . . . . . 1923<sup>b</sup> (Gummey)
- Justle . . . . . 1788<sup>b</sup>  
 Justus . . . . . 1788<sup>b</sup> (S. F. Hunter)  
 cf Joseph Barsabbas . . . 1740<sup>a</sup> (Kerr)  
 cf Titus, or Titius Jus-  
 tus . . . . . 2989<sup>b</sup> (Rutherford)
- Juttah . . . . . 1788<sup>b</sup> (Masterman)
- Kab . . . . . 1788<sup>a</sup>  
 cf Weights and Meas-  
 ures . . . . . 3079<sup>a</sup> (Porter)
- Kabzeel . . . . . 1788<sup>a</sup>  
 Kadesh . . . . . 1788<sup>b</sup>  
 cf Kadesh-barnea . . . . . 1788<sup>b</sup> (S. F. Hunter)  
 Kadesh-barnea . . . . . 1788<sup>b</sup> (S. F. Hunter)  
 cf Kedesh . . . . . 1790<sup>b</sup> (Ewing)  
 cf Wanderings of Is-  
 rael . . . . . 3064<sup>a</sup> (Conder)
- Kadesh in Galilee  
 cf Kedesh . . . . . 1790<sup>b</sup> (Ewing)
- Kadesh on the Orontes . . 1789<sup>a</sup> (Christie)
- Kadmiel . . . . . 1789<sup>a</sup>  
 Kadmonite . . . . . 1789<sup>a</sup> (Sayce)  
 cf Kedemah . . . . . 1790<sup>b</sup>
- Kahtan, Kahtanite . . . . 217<sup>b</sup> (Weir)
- Kain . . . . . 1789<sup>b</sup>  
 Kain (place) . . . . . 1789<sup>b</sup> (Masterman)
- Kallai . . . . . 1789<sup>b</sup>  
 Kamon . . . . . 1789<sup>b</sup> (Ewing)  
 cf Havvoth-jair . . . . . 1345<sup>a</sup> (Ewing)
- Kanah . . . . . 1789<sup>b</sup> (Ewing)  
 Kant . . . . . 1019<sup>b</sup>  
 Kaph . . . . . 1789<sup>b</sup>  
 cf Alphabet . . . . . 103<sup>b</sup> (Richardson)
- Karaites . . . . . 685<sup>b</sup> (Oko)
- Kareah . . . . . 1790<sup>a</sup>  
 Kariatharius . . . . . 1790<sup>a</sup>  
 Karka . . . . . 1790<sup>a</sup>
- Karkar, Battle of  
 cf Israel, Kingdom of . . 1529<sup>b</sup> (Weir)  
 cf Jehu . . . . . 1586<sup>a</sup> (Caldecott)
- Karkor . . . . . 1790<sup>a</sup>  
 Karma . . . . . 692<sup>b</sup> (Tisdall)
- Karnak  
 cf Shishak . . . . . 2778<sup>a</sup> (Nicol)
- Kartah . . . . . 1790<sup>a</sup>  
 cf Kartan . . . . . 1790<sup>a</sup>  
 cf Kattath . . . . . 1790<sup>a</sup> (Ewing)
- Kartan . . . . . 1790<sup>a</sup>  
 cf Kartah . . . . . 1790<sup>a</sup>
- Kattath . . . . . 1790<sup>a</sup> (Ewing)  
 cf Kartah . . . . . 1790<sup>a</sup>
- Kedar . . . . . 1790<sup>a</sup> (Fulton)
- Kedemah . . . . . 1790<sup>b</sup>  
 cf Kadmonite . . . . . 1789<sup>a</sup> (Sayce)
- Kedemoth . . . . . 1790<sup>a</sup>  
 cf Jahaz . . . . . 1558<sup>a</sup> (Ewing)
- Kedesh . . . . . 1790<sup>b</sup> (Ewing); 1791<sup>a</sup>  
 cf Kadesh-barnea . . . . 1788<sup>b</sup> (S. F. Hunter)  
 cf Kishion . . . . . 1813<sup>a</sup>  
 cf Refuge, Cities of . . . 2545<sup>b</sup> (Ewing)
- Kedesh-naphtali  
 cf Kedesh . . . . . 1790<sup>b</sup> (Ewing)  
 cf Naphtali . . . . . 2118<sup>b</sup> (Ewing)
- Keeper, Keepers . . . . . 1791<sup>a</sup>
- Kehelathah . . . . . 1791<sup>a</sup>  
 cf Wanderings of Israel 3064<sup>a</sup> (Conder)
- Keilah . . . . . 1791<sup>a</sup> (Masterman)  
 David's refuge . . . . . 1791<sup>a</sup>  
 cf Garmite . . . . . 1175<sup>b</sup>  
 Identification of . . . . 1791<sup>a</sup>
- Kelaiah . . . . . 1791<sup>b</sup>
- Kelita  
 cf Kelaiah . . . . . 1791<sup>b</sup>
- Kemuel . . . . . 1791<sup>b</sup>
- Kenan . . . . . 1791<sup>b</sup>; 141<sup>a</sup> (Davis)
- Kenath . . . . . 1791<sup>b</sup> (Ewing)
- Kenaz . . . . . 1791<sup>b</sup>  
 cf Kenezite . . . . . 1791<sup>b</sup>  
 cf Uknaz . . . . . 3032<sup>a</sup>
- Kenez . . . . . 1791<sup>b</sup>
- Kenezite . . . . . 1791<sup>b</sup>  
 cf Kenaz . . . . . 1791<sup>b</sup>
- Kenite  
 cf Rechab, Rechabites 2535<sup>b</sup> (Mack)
- Kenites . . . . . 1792<sup>a</sup> (Ewing)  
 cf Cain . . . . . 539<sup>b</sup> (Farr)  
 cf Jethro . . . . . 1674<sup>b</sup> (Crichton)  
 cf Midian, Midianites . 2049<sup>b</sup> (Ewing)
- Kenizzite  
 cf Kenezite . . . . . 1791<sup>b</sup>
- Kenosis . . . . . 1792<sup>a</sup> (Easton)  
 cf Accommodation . . . . 33<sup>a</sup> (Sweet)  
 Character of Divine  
 knowledge . . . . . 1792<sup>b</sup>  
 Difficulties of theory . . 1792<sup>b</sup>  
 cf Humiliation of  
 Christ . . . . . 1439<sup>b</sup>  
 Ignorance not incon-  
 sistent with omnis-  
 cience . . . . . 1793<sup>a</sup>  
 Limitations of Jesus'  
 knowledge . . . . . 1792<sup>a</sup>  
 Meaning of term . . . . . 1792<sup>a</sup>  
 cf Parousia . . . . . 2249<sup>a</sup> (Easton)  
 cf Person of Christ . . . 2338<sup>a</sup> (Warfield)  
 cf Philippians, Epistle  
 to . . . . . 2374<sup>a</sup> (Hayes)  
 cf Prize . . . . . 2457<sup>a</sup> (Edwards)  
 cf Reputation . . . . . 2561<sup>a</sup>

- Keras . . . . . 1793<sup>a</sup>  
 Kerechief . . . . . 1793<sup>a</sup>  
   of Mantle . . . . . 1984<sup>a</sup>  
 Keren-happuch . . . . . 1793<sup>a</sup>  
 Kerioth . . . . . 1793<sup>a</sup> (Ewing)  
   of Kerioth-hezron . . . . . 1793<sup>b</sup>  
 Kerioth-hezron . . . . . 1793<sup>b</sup>  
   of Hazor . . . . . 1347<sup>b</sup> (Ewing)  
   of Judas Iscariot . . . . . 1765<sup>b</sup> (Kerr)  
   of Kerioth . . . . . 1793<sup>a</sup> (Ewing)  
 Kernel . . . . . 1793<sup>b</sup>  
 Keros . . . . . 1793<sup>b</sup>  
   of Nethinim . . . . . 2139<sup>b</sup> (Lees)  
 Kesil  
   of Astronomy . . . . . 300<sup>b</sup> (Maunder)  
 Kesitah . . . . . 1793<sup>b</sup>  
   of Piece of Money . . . . . 2394<sup>b</sup>  
 Ketab . . . . . 1793<sup>b</sup>  
 Kettle . . . . . 1793<sup>b</sup>  
 Keturah . . . . . 1793<sup>b</sup> (Baur)  
 Key . . . . . 1793<sup>b</sup> (Pollard)  
   of House . . . . . 1434<sup>b</sup> (A. C. Dickie)  
 Keys, Power of . . . . . 1794<sup>a</sup> (Carver)  
   of Absolution . . . . . 24<sup>a</sup> (Jacobs)  
   Authority or duty? . . . . . 1794<sup>b</sup>  
   Binding and loosing  
     sins . . . . . 1796<sup>b</sup>  
   Catholic and Protes-  
     tant views . . . . . 1794<sup>b</sup>  
   Church and kingdom . . . . . 1795<sup>b</sup>  
   Civil authority . . . . . 1795<sup>a</sup>  
   Examples of use . . . . . 1796<sup>b</sup>  
   Extent of powers . . . . . 1794<sup>b</sup>  
   Figurative meaning . . . . . 1794<sup>a</sup>  
   Forgiveness of sins . . . . . 1795<sup>a</sup>  
   Functions of holder . . . . . 1795<sup>a</sup>  
   of Hands, Imposition of 1335<sup>a</sup> (Orr)  
   Importance of subject 1794<sup>a</sup>  
   Keys and binding . . . . . 1794<sup>a</sup>  
   Limits of power . . . . . 1794<sup>b</sup>  
   of Lord . . . . . 1796<sup>a</sup>; 1919<sup>a</sup> (Carver)  
   In Luke 11 52 . . . . . 1796<sup>a</sup>  
   May belong to anyone 1797<sup>a</sup>  
   Meaning of Matthew  
     16 19 . . . . . 1795<sup>a</sup>  
   Not official, but per-  
     sonal . . . . . 1796<sup>b</sup>  
   of Peter (Simon) . . . . . 2348<sup>b</sup> (Gray)  
   Redemptive power  
     only . . . . . 1797<sup>a</sup>  
   Related Scripture . . . . . 1796<sup>a</sup>  
   In Rev 1 18 . . . . . 1795<sup>b</sup>  
   In Rev 3 7 . . . . . 1795<sup>b</sup>  
   of Rock . . . . . 2596<sup>a</sup> (Day)  
   Rock and stone . . . . . 1795<sup>b</sup>  
 Keziah . . . . . 1797<sup>a</sup>  
 Keziz  
   of Emek-keziz . . . . . 940<sup>b</sup>  
 Keziz, Valley of  
   of Emek-keziz . . . . . 940<sup>b</sup>  
 Khan  
   of Inn . . . . . 1470<sup>a</sup> (Christie)
- Khorsabad  
   of Nineveh . . . . . 2148<sup>b</sup> (Pinches)  
 Kibroth-hattaavah . . . . . 1797<sup>a</sup>  
 Kibzaim  
   of Jokmeam . . . . . 1727<sup>a</sup>  
 Kick . . . . . 1797<sup>a</sup>  
 Kid . . . . . 1797<sup>b</sup>  
   of Goat . . . . . 1248<sup>b</sup> (Day)  
 Kidnapping . . . . . 1797<sup>b</sup>; 747<sup>a</sup> (Hirsch)  
 Kidneys . . . . . 1797<sup>b</sup> (Easton)  
   of Fat . . . . . 1099<sup>b</sup> (Luering)  
   of Psychology . . . . . 2494<sup>b</sup> (Marais)  
   of Reins . . . . . 2553<sup>b</sup> (Luering)  
   of Sacrifice, OT . . . . . 2638<sup>a</sup> (Reeve)  
 Kidron . . . . . 1798<sup>a</sup>  
   of Hinnom, Valley of . . . . . 1393<sup>b</sup> (Masterman)  
   of Jehoshaphat, Valley  
     of . . . . . 1583<sup>a</sup> (Masterman)  
   of Jerusalem . . . . . 1599<sup>a</sup> (Masterman)  
 Kidron, The Brook . . . . . 1798<sup>a</sup> (Masterman)  
   Burning place for idols 1798<sup>b</sup>  
   David's crossing of . . . . . 1798<sup>b</sup>  
   East of Jerusalem . . . . . 1798<sup>a</sup>  
   of Gehenna . . . . . 1183<sup>a</sup> (Vos)  
   of Jehoshaphat, Valley  
     of . . . . . 1583<sup>a</sup> (Masterman)  
   of King's Garden . . . . . 1808<sup>a</sup> (Masterman)  
   of Siloam . . . . . 2791<sup>a</sup> (Masterman)  
   of Topheth . . . . . 2999<sup>b</sup> (Masterman)  
   Traditional scene of  
     judgment . . . . . 1798<sup>a</sup>  
 Kilan (Ceilan) . . . . . 1798<sup>a</sup>  
 Kimah  
   of Astronomy . . . . . 300<sup>b</sup> (Maunder)  
 Kin  
   of Kindred . . . . . 1799<sup>a</sup> (Pollard)  
 Kiu, Next of  
   of Kinsman . . . . . 1810<sup>a</sup> (Pollard)  
 Kinah . . . . . 1798<sup>b</sup>  
 Kindness . . . . . 1799<sup>a</sup> (W. L. Walker)  
   of Gentleness . . . . . 1215<sup>b</sup> (W. L. Walker)  
   of Goodness . . . . . 1279<sup>a</sup> (W. L. Walker)  
   of Lovingkindness . . . . . 1934<sup>a</sup> (W. L. Walker)  
   of Mercy . . . . . 2035<sup>b</sup> (W. L. Walker)  
 Kindred . . . . . 1799<sup>a</sup>  
   of Kinsman . . . . . 1810<sup>a</sup> (Pollard)  
 Kine . . . . . 1799<sup>a</sup>  
   of Cattle . . . . . 583<sup>b</sup> (Day)  
   of Cow . . . . . 734<sup>a</sup> (Day)  
 King, Christ as . . . . . 1802<sup>a</sup> (M'Caig)  
   By achievement . . . . . 1803<sup>b</sup>  
   Christ's acceptance of  
     title . . . . . 1802<sup>b</sup>  
   Christ charged with  
     being king . . . . . 1803<sup>a</sup>  
   Christ's claim to king-  
     ship . . . . . 1802<sup>b</sup>  
   of Christ, Offices of . . . . . 616<sup>b</sup> (Bevan)  
   Divinely appointed . . . . . 1803<sup>b</sup>  
   Eternal rule . . . . . 1804<sup>b</sup>  
   Foreshadowings (OT) . . . . . 1802<sup>a</sup>  
   Grace, power, glory . . . . . 1804<sup>b</sup>

- King, Christ as—*continued*  
 Missionary extension . . . 1804<sup>a</sup>  
 Nature of His kingship . . . . . 1803<sup>b</sup>  
 Reality of Christ's kingship . . . . . 1802<sup>a</sup>  
 Right by birth . . . . . 1803<sup>a</sup>  
 So presented in Gospels . . . . . 1802<sup>b</sup>  
 Spiritual authority . . . 1803<sup>b</sup>  
 Testimony of Epistles and apocalypse . . . . . 1803<sup>a</sup>  
 Universal dominion . . . 1804<sup>a</sup>
- King of the Jews . . . . . 1805<sup>a</sup>  
 cf Jesus Christ . . . . . 1624<sup>a</sup> (Orr)  
 cf King, Christ as . . . . . 1802<sup>a</sup> (M'Caig)
- King, Kingdom . . . . . 1799<sup>a</sup> (Press)  
 Absolute ruler . . . . . 1799<sup>b</sup>  
 Ancient rulers . . . . . 1799<sup>b</sup>  
 Authority of king . . . 1801<sup>a</sup>  
 Choice of king . . . . . 1800<sup>b</sup>  
 Davidic ideal . . . . . 1801<sup>b</sup>  
 Disadvantages of Hebrew system . . . . . 1800<sup>a</sup>  
 Duties of . . . . . 1801<sup>a</sup>  
 Lateness of Hebrew kingdom . . . . . 1799<sup>b</sup>  
 Meaning of term . . . . . 1799<sup>b</sup>  
 Period of Judges . . . . . 1800<sup>a</sup>  
 cf Reign . . . . . 2553<sup>a</sup> (Baur)  
 Revenue of . . . . . 1801<sup>b</sup>  
 Royal court . . . . . 1801<sup>b</sup>  
 Samuel and monarchy 1800<sup>b</sup>  
 Strength of Hebrew plan . . . . . 1800<sup>a</sup>  
 Symbols of royalty . . . 1801<sup>a</sup>  
 Theocracy . . . . . 1800<sup>a</sup>  
 cf Throne . . . . . 2976<sup>a</sup> (Baur)
- Kingdom of God (of Heaven), The . . . . . 1805<sup>a</sup> (Stalker)  
 In apostolic age . . . . . 1807<sup>a</sup>  
 Contrast between Jesus' view and Jewish conception . . . . . 1806<sup>a</sup>  
 Current Jewish views 1806<sup>a</sup>  
 Danger of exaggeration . . . . . 1807<sup>b</sup>  
 In early centuries . . . 1807<sup>b</sup>  
 Futurist views . . . . . 1806<sup>b</sup>  
 Historical growth of ideal . . . . . 1807<sup>a</sup>  
 cf Hope . . . . . 1419<sup>b</sup> (Easton)  
 Importance in Synoptists . . . . . 1805<sup>a</sup>  
 cf Israel, Kingdom of. 1528<sup>b</sup> (Weir)  
 cf Jesus Christ . . . . . 1630<sup>a</sup> (Orr)  
 Jesus' attitude toward Jewish view . . . . . 1806<sup>a</sup>  
 Jesus' conceptions . . . 1807<sup>a</sup>  
 Jesus' use of title . . . 1806<sup>a</sup>  
 "Kingdom of Heaven" and "of God" . . . . . 1805<sup>b</sup>
- Kingdom of God (of Heaven), The—*continued*  
 Meaning and origin of term . . . . . 1805<sup>a</sup>  
 Modern views . . . . . 1807<sup>b</sup>  
 In OT (Daniel) . . . . . 1805<sup>b</sup>  
 cf Parousia . . . . . 2249<sup>a</sup> (Easton)  
 Place in theology . . . 1807<sup>b</sup>  
 In Reformation age . . 1807<sup>b</sup>  
 cf Salvation . . . . . 2667<sup>b</sup> (Easton)  
 cf Sermon on the Mount, The . . . . . 2734<sup>a</sup> (Miller)  
 Value of the idea . . . . . 1807<sup>b</sup>
- Kingdom of Israel . . . . . 1528<sup>b</sup> (Weir)  
 Kingdom of Judah . . . . . 1758<sup>a</sup> (Weir)  
 cf Israel, Kingdom of. 1528<sup>b</sup> (Weir)
- King's Dale . . . . . 777<sup>b</sup> (Masterman)  
 King's Garden . . . . . 1808<sup>a</sup> (Masterman)  
 cf Kidron, The Brook 1798<sup>a</sup> (Masterman)  
 cf Siloam . . . . . 2791<sup>a</sup> (Masterman)
- King's Mother . . . . . 1808<sup>a</sup>  
 cf Queen . . . . . 2513<sup>b</sup> (Baur)  
 cf Queen Mother . . . . 2513<sup>b</sup> (Baur)
- King's Pool . . . . . 1808<sup>a</sup>  
 cf Jerusalem Gates . . . 1597<sup>b</sup>; 1608<sup>a</sup> (Masterman)
- King's Vale . . . . . 1808<sup>a</sup> (Masterman)  
 cf Jehoshaphat, Valley of . . . . . 1583<sup>a</sup> (Masterman)  
 cf Salem . . . . . 2663<sup>a</sup> (Pinches)
- Kings, Books of . . . . . 1808<sup>b</sup> (Stearns)  
 Character and position . . . . . 1809<sup>a</sup>  
 Chronological value . . 1809<sup>a</sup>  
 Compilations . . . . . 1809<sup>b</sup>  
 Composition . . . . . 1809<sup>b</sup>  
 Date . . . . . 1810<sup>a</sup>  
 Historical value . . . . . 1809<sup>a</sup>  
 Kent's outline . . . . . 1809<sup>b</sup>  
 Prominence of moral motive . . . . . 1809<sup>a</sup>  
 Scope and contents . . . 1808<sup>b</sup>  
 Sources . . . . . 1809<sup>b</sup>  
 Title . . . . . 1808<sup>b</sup>
- Kings' Sepulchres  
 cf Jerusalem . . . . . 1611<sup>b</sup> (Masterman)
- Kingsfolk  
 cf Kindred . . . . . 1799<sup>a</sup> (Pollard)
- Kinsman . . . . . 1810<sup>a</sup> (Pollard)  
 cf Kindred . . . . . 1799<sup>a</sup> (Pollard)
- Kinswoman . . . . . 1810<sup>a</sup> (Pollard)
- Kir . . . . . 1810<sup>b</sup> (Pinches)  
 In Isaiah 22 5 . . . . . 1810<sup>b</sup>  
 Meaning of word . . . . 1810<sup>b</sup>  
 Soldiers of . . . . . 1810<sup>b</sup>  
 Was it a place? . . . . . 1810<sup>b</sup>
- Kir of Moab . . . . . 1810<sup>b</sup> (Ewing)  
 cf Kiriath-huzoth . . . . 1811<sup>b</sup>
- Kirama (Cirama) . . . . . 1811<sup>a</sup>
- Kir-hareseth . . . . . 1811<sup>a</sup> (Ewing)  
 Kir-heres (Kir-hareseth) 1811<sup>a</sup> (Ewing)
- Kiriath . . . . . 1811<sup>b</sup>  
 cf Kiriath-jearim . . . . 1811<sup>b</sup> (Masterman)
- Kiriathaim . . . . . 1811<sup>b</sup> (Ewing)

- Kiriath-arba  
   cf Hebron . . . . . 1365<sup>a</sup> (Masterman)
- Kiriath-arim  
   cf Kiriath-jearim . . . . . 1811<sup>b</sup> (Masterman)
- Kiriath-baal  
   cf Kiriath-jearim . . . . . 1811<sup>b</sup> (Masterman)
- Kiriath-huzoth . . . . . 1811<sup>b</sup>  
   cf Kir of Moab . . . . . 1810<sup>b</sup> (Ewing)
- Kiriath-jearim . . . . . 1811<sup>b</sup> (Masterman)  
   Identifications . . . . . 1812<sup>a</sup>  
   cf Jaar . . . . . 1545<sup>b</sup>  
   cf Kiriath . . . . . 1811<sup>b</sup>  
   Location . . . . . 1812<sup>a</sup>  
   cf Mahaneh-dan . . . . . 1966<sup>b</sup> (Ewing)  
   OT references . . . . . 1811<sup>b</sup>
- Kiriath-sannah . . . . . 1812<sup>b</sup>  
   cf Kiriath-sepher . . . . . 1812<sup>b</sup>
- Kiriath-sepher . . . . . 1812<sup>b</sup>  
   cf Kiriath-sannah . . . . . 1812<sup>b</sup>
- Kirjath  
   cf Kiriath . . . . . 1811<sup>b</sup>
- Kirjathaim (Kiriathaim) 1811<sup>b</sup> (Ewing)
- Kirjath-arba  
   cf Hebron . . . . . 1365<sup>a</sup> (Masterman)
- Kirjath-baal  
   cf Kiriath-jearim . . . . . 1811<sup>b</sup> (Masterman)
- Kiseus . . . . . 1813<sup>a</sup>  
   cf Kish . . . . . 1813<sup>a</sup> (Baur)
- Kish . . . . . 1813<sup>a</sup> (Baur); 364<sup>b</sup> (Clay)  
   cf Kiseus . . . . . 1813<sup>a</sup>  
   cf Saul . . . . . 2697<sup>b</sup> (Weir)
- Kishi . . . . . 1813<sup>a</sup>  
   cf Kushaiah . . . . . 1818<sup>b</sup>
- Kishion . . . . . 1813<sup>a</sup>  
   cf Kedesh . . . . . 1790<sup>b</sup> (Ewing)
- Kishon . . . . . 1813<sup>a</sup> (Ewing)  
   cf Jokneam . . . . . 1727<sup>a</sup> (Ewing)
- Kislev (Chisleu, Chislev) 1813<sup>b</sup>  
   cf Calendar . . . . . 541<sup>b</sup> (Porter)
- Kiss . . . . . 1813<sup>b</sup> (W. L. Walker)  
   cf Adoration . . . . . 60<sup>a</sup> (Edwards)
- Kisurra . . . . . 365<sup>a</sup> (Clay)
- Kite . . . . . 1814<sup>a</sup> (Stratton-Porter)  
   cf Hawk . . . . . 1345<sup>a</sup> (Stratton-Porter)
- Kithlish  
   cf Chitlish . . . . . 612<sup>a</sup>
- Kitron . . . . . 1814<sup>a</sup>
- Kittim . . . . . 1814<sup>b</sup> (Pinches)  
   Assyrians in Cyprus . . . . . 1814<sup>b</sup>  
   Colonization of Cyprus . . . . . 1814<sup>b</sup>  
   Cyprian art . . . . . 1815<sup>a</sup>  
   cf Cyprus . . . . . 771<sup>a</sup> (Tod)  
   Name for Cyprus . . . . . 1814<sup>b</sup>  
   Name for western coast lands . . . . . 1814<sup>b</sup>  
   Races and languages of Cyprus . . . . . 1815<sup>a</sup>  
   Two uses of name . . . . . 1814<sup>b</sup>
- Kneading  
   cf Bread . . . . . 514<sup>b</sup> (Eager)
- Knee, Kneel . . . . . 1815<sup>a</sup> (Easton)  
   cf Attitudes . . . . . 329<sup>a</sup> (W. W. Davies)  
   cf Salutation . . . . . 2665<sup>a</sup> (Pollard)  
   cf Thigh . . . . . 2972<sup>b</sup> (Easton)
- Knife . . . . . 1815<sup>b</sup> (Pollard)  
   cf Tools . . . . . 2998<sup>b</sup> (Easton)
- Knock . . . . . 1815<sup>b</sup> (Miller)
- Knop . . . . . 1815<sup>b</sup>  
   cf Temple . . . . . 2930<sup>a</sup> (Caldecott; Orr)
- Know, Knowledge . . . . . 1815<sup>b</sup> (Orr)  
   cf Foreknowledge . . . . . 1128<sup>a</sup> (Hodge)
- Koa . . . . . 1816<sup>a</sup>
- Kohath, Kohathites . . . . . 1816<sup>a</sup> (Orr)
- Koheleth  
   cf Ecclesiastes . . . . . 894<sup>b</sup> (Beecher)
- Kolaiah . . . . . 1816<sup>b</sup>
- Konae . . . . . 1816<sup>b</sup>
- Koph . . . . . 1816<sup>b</sup>  
   cf Alphabet . . . . . 103<sup>b</sup> (Richardson)
- Kor  
   cf Cor . . . . . 709<sup>a</sup>
- Korah . . . . . 1816<sup>b</sup> (Beecher)  
   cf Abiram . . . . . 12<sup>b</sup> (Beecher)  
   Character of the narrative . . . . . 1817<sup>a</sup>  
   Destroyed with his company . . . . . 1816<sup>a</sup>  
   cf Hebron (person) . . . . . 1366<sup>b</sup>  
   cf Kore . . . . . 1818<sup>b</sup> (Beecher)  
   Moses' warning . . . . . 1817<sup>a</sup>
- Korahites . . . . . 1817<sup>b</sup> (Beecher)  
   Duties of . . . . . 1817<sup>b</sup>  
   Genealogical details . . . . . 1817<sup>b</sup>  
   cf Kore . . . . . 1818<sup>b</sup> (Beecher)  
   Musical service of . . . . . 1818<sup>a</sup>  
   Relation to Psalms . . . . . 1818<sup>a</sup>  
   Temple of music . . . . . 1818<sup>a</sup>
- Korathites  
   cf Korah . . . . . 1816<sup>b</sup> (Beecher)
- Kore . . . . . 1818<sup>b</sup> (Beecher)  
   cf Korah . . . . . 1816<sup>b</sup> (Beecher)  
   cf Korahites . . . . . 1817<sup>b</sup> (Beecher)
- Korhites . . . . . 1818<sup>b</sup>  
   cf Korah . . . . . 1816<sup>b</sup> (Beecher)
- Koz  
   cf Hakkoz . . . . . 1321<sup>b</sup>
- Kushaiah . . . . . 1818<sup>b</sup>  
   cf Kishi . . . . . 1813<sup>a</sup>
- Laadah . . . . . 1819<sup>a</sup>
- Laadan  
   cf Ladan . . . . . 1821<sup>a</sup>
- Laban . . . . . 1819<sup>a</sup> (Boyd)  
   Character of . . . . . 1819<sup>b</sup>  
   cf Jacob . . . . . 1550<sup>b</sup> (Boyd)  
   Name and genealogy . . . . . 1919<sup>a</sup>  
   cf Paddan-aram . . . . . 2206<sup>b</sup> (Christie)  
   Relations with Jacob . . . . . 1819<sup>a</sup>
- Labana . . . . . 1819<sup>b</sup>
- Labor . . . . . 1819<sup>b</sup> (Orr)  
   cf Slavery . . . . . 2815<sup>a</sup> (Raffety)  
   cf Travail . . . . . 3007<sup>a</sup> (Macalister)  
   cf Work . . . . . 3105<sup>b</sup> (W. L. Walker)

- Laccunus . . . . . 1819<sup>b</sup>  
 Lace . . . . . 1819<sup>b</sup>  
 Lacedaemonians . . . . . 1819<sup>b</sup> (Hutchison)  
   cf Arius . . . . . 242<sup>a</sup>  
   cf Maccabaeus, Macca-  
   bees . . . . . 1947<sup>a</sup> (Hutchison)  
   cf Sparta, Spartans . . . . . 2839<sup>b</sup> (Orr)  
 Lachish . . . . . 1820<sup>a</sup> (Porter)  
   Destruction of . . . . . 1820<sup>b</sup>  
   Excavation of . . . . . 1820<sup>a</sup>  
   History of . . . . . 1820<sup>b</sup>  
   Location . . . . . 1820<sup>a</sup>  
   of Palestine . . . . . 2212<sup>a</sup> (Conder)  
   of Palestine, Recent  
   Exploration . . . . . 2225<sup>b</sup> (Cobern)  
 Lack . . . . . 1821<sup>a</sup> (Gerberding)  
 Lacunus  
   cf Laccunus . . . . . 1819<sup>b</sup>  
 Lad . . . . . 1821<sup>a</sup>  
 Ladan . . . . . 1821<sup>a</sup>  
   cf Libni . . . . . 1882<sup>a</sup>  
 Ladanum . . . . . 1821<sup>a</sup>  
   cf Myrrh . . . . . 2102<sup>a</sup> (Masterman)  
 Ladder  
   cf Siege . . . . . 2786<sup>a</sup> (Nicol)  
 Ladder of Tyre . . . . . 1821<sup>a</sup> (Porter)  
   cf Misrephoth-maim . . . . . 2067<sup>a</sup> (Porter)  
   cf Phoenicia . . . . . 2386<sup>b</sup> (Porter)  
 Lade, Lading . . . . . 1821<sup>b</sup>  
 Lady . . . . . 1821<sup>b</sup>  
   cf Cyria . . . . . 773<sup>b</sup>  
   cf Elect Lady . . . . . 925<sup>a</sup> (Law)  
   cf John, Epistles of . . . . . 1711<sup>a</sup> (Law)  
 Lael . . . . . 1821<sup>b</sup>  
 Lagash . . . . . 364<sup>b</sup> (Clay)  
 Lahad . . . . . 1821<sup>b</sup>  
 Lahai-roi  
   cf Beer-lahai-roi . . . . . 424<sup>a</sup> (S. F. Hunter)  
 Lahmam . . . . . 1821<sup>b</sup>  
 Lahmas  
   cf Lahmam . . . . . 1821<sup>b</sup>  
 Lahmi . . . . . 1821<sup>b</sup>  
   cf Elhanan . . . . . 928<sup>a</sup> (Sampey)  
   cf Goliath . . . . . 1276<sup>b</sup> (Reeve)  
 Laish . . . . . 1821<sup>b</sup>  
   cf Dan . . . . . 781<sup>a</sup> (Ewing)  
 Laishah . . . . . 1822<sup>a</sup>  
 Lake . . . . . 1822<sup>a</sup> (Day)  
   cf Pool . . . . . 2419<sup>b</sup> (Day)  
 Lake of Fire . . . . . 1822<sup>a</sup> (Vos)  
 Lake of Gennesaret  
   cf Galilee, Sea of . . . . . 1165<sup>a</sup> (Ewing)  
 Lakkum . . . . . 1822<sup>b</sup>  
 Lama  
   cf Eloi, Eloi, Lama Sa-  
   bachthani . . . . . 939<sup>a</sup> (Clippinger)  
 Lamb . . . . . 1822<sup>b</sup> (Day)  
   cf Sheep . . . . . 2756<sup>b</sup> (Day)  
 Lamb of God . . . . . 1822<sup>b</sup> (Bevan)  
   In the apocalypse . . . . . 1823<sup>a</sup>  
   Historical interpre-  
   tations . . . . . 1823<sup>a</sup>  
 Lamb of God—*continued*  
   Origin of term . . . . . 1822<sup>b</sup>  
   Sacrificial sense . . . . . 1822<sup>b</sup>  
   In Second Isaiah . . . . . 1823<sup>a</sup>  
 Lame . . . . . 1823<sup>b</sup> (Macalister)  
   cf Cripple . . . . . 748<sup>b</sup>  
 Lamech . . . . . 1823<sup>b</sup> (Baur)  
   cf Polygamy of . . . . . 1095<sup>a</sup> (Caverno)  
 Lamedh . . . . . 1824<sup>a</sup>  
   cf Alphabet . . . . . 103<sup>b</sup> (Richardson)  
 Lament  
   cf Music . . . . . 2094<sup>b</sup> (Millar)  
 Lamentation  
   cf Burial . . . . . 529<sup>a</sup> (Eager)  
 Lamentations, Book of . . . . . 1824<sup>a</sup> (Orelli)  
   Author of . . . . . 1824<sup>b</sup>  
   Contents . . . . . 1824<sup>a</sup>  
   Critical view . . . . . 1824<sup>b</sup>  
   The five elegies . . . . . 1824<sup>a</sup>  
   Name . . . . . 1824<sup>a</sup>  
   Position in Canon . . . . . 1825<sup>a</sup>  
 Lamp, Lampstand . . . . . 1825<sup>a</sup> (Porter)  
   cf Candlestick, Golden 553<sup>a</sup> (Orr)  
   Figurative use . . . . . 1825<sup>b</sup>  
   Forms and history . . . . . 1825<sup>b</sup>  
   Funeral use of . . . . . 1826<sup>a</sup>  
   Inscriptions . . . . . 1826<sup>a</sup>  
   Material and design . . . . . 1825<sup>b</sup>  
   cf Oil . . . . . 2181<sup>b</sup> (Patch)  
   cf Torch . . . . . 2999<sup>b</sup>  
   Use of term . . . . . 1825<sup>a</sup>  
 Lampsacus  
   cf Sampsames . . . . . 2675<sup>a</sup>  
 Lance, Lancer, Lancet  
   cf Armor, Arms . . . . . 251<sup>a</sup> (Nicol)  
 Land . . . . . 1826<sup>b</sup> (Day)  
   cf Country . . . . . 724<sup>a</sup> (Day)  
   cf Earth . . . . . 887<sup>a</sup> (Day)  
 Land-crocodile . . . . . 1826<sup>b</sup> (Day)  
   cf Chameleon . . . . . 592<sup>a</sup> (Day)  
   cf Lizard . . . . . 1906<sup>a</sup> (Day)  
 Land Laws  
   cf Agrarian Laws . . . . . 74<sup>a</sup> (Wiener)  
 Landmark . . . . . 1826<sup>b</sup>  
 Lane . . . . . 1826<sup>b</sup>  
 Language of the NT . . . . . 1826<sup>b</sup> (A. T. Robertson)  
   cf Aramaic Language . . . . . 222<sup>a</sup> (J. E. H. Thomson)  
   Character of the *koinē* 1829<sup>b</sup>  
   Comparison of Biblical  
   and common words. 1830<sup>a</sup>  
   Evidence from gram-  
   mar . . . . . 1829<sup>a</sup>  
   Evidence from inscrip-  
   tions . . . . . 1828<sup>b</sup>  
   Evidence from modern  
   grammar . . . . . 1829<sup>a</sup>  
   Evidence from ostraca 1828<sup>b</sup>  
   Evidence from the pa-  
   pyri . . . . . 1828<sup>a</sup>  
   The *koinē* of the first  
   century . . . . . 1827<sup>a</sup>  
   cf Latin . . . . . 1840<sup>b</sup> (A. T. Robertson)

- Language of the NT—*continued*  
 Literary elements in  
 NT . . . . . 1830<sup>b</sup>  
 The newer view . . . . . 1827<sup>a</sup>  
 Old view of a Divine  
 speech . . . . . 1826<sup>b</sup>  
 of Papyrus . . . . . 2238<sup>b</sup> (Goodspeed)  
 Peculiarities of writers . 1831<sup>b</sup>  
 Recent workers in . . . . . 1827<sup>b</sup>  
 of Roman Empire and  
 Christianity . . . . . 2601<sup>a</sup> (Angus)  
 Semitic influence . . . . . 1831<sup>a</sup>  
 of Septuagint . . . . . 2722<sup>a</sup> (Thackeray)  
 Speech of Jesus . . . . . 1832<sup>a</sup>
- Languages of the OT . . . . . 1832<sup>a</sup> (Weir)  
 Absence of tenses . . . . . 1834<sup>b</sup>  
 Adjectives few . . . . . 1835<sup>b</sup>  
 Aramaic . . . . . 1835<sup>b</sup>  
 Aramaic and Hebrew  
 compared . . . . . 1835<sup>b</sup>  
 Concrete nature of He-  
 brew . . . . . 1836<sup>a</sup>  
 Construct state of  
 noun . . . . . 1835<sup>a</sup>  
 Derived stems . . . . . 1834<sup>b</sup>  
 Differences of age and  
 style . . . . . 1833<sup>b</sup>  
 Ease of translation . . . . . 1836<sup>a</sup>  
 Foreign influences . . . . . 1833<sup>b</sup>  
 Guttural sounds . . . . . 1834<sup>a</sup>  
 Hebrew is a Canaanite  
 language . . . . . 1833<sup>b</sup>  
 Hebrew, characteristics  
 of . . . . . 1834<sup>a</sup>  
 Hebrew, death of . . . . . 1834<sup>a</sup>  
 Hebrew, history of . . . . . 1833<sup>a</sup>  
 Hebrew of the OT . . . . . 1833<sup>a</sup>  
 Hebrew remains . . . . . 1833<sup>a</sup>  
 Hebrew, a younger  
 speech . . . . . 1834<sup>a</sup>  
 Internal inflexion . . . . . 1835<sup>a</sup>  
 of Lamentations, Book  
 of . . . . . 1836<sup>a</sup>; 1824<sup>a</sup> (Orelli)  
 Literary characteris-  
 tics . . . . . 1836<sup>a</sup>  
 More sounds than let-  
 ters . . . . . 1834<sup>b</sup>  
 Name of formation . . . . . 1834<sup>b</sup>  
 Name Hebrew . . . . . 1832<sup>b</sup>  
 Oldest form of Hebrew 1833<sup>a</sup>  
 Picturesqueness of He-  
 brew . . . . . 1836<sup>a</sup>  
 Pronouns . . . . . 1834<sup>b</sup>  
 Prose and poetry . . . . . 1833<sup>b</sup>  
 Semitic groups . . . . . 1832<sup>b</sup>  
 Semitic languages . . . . . 1832<sup>b</sup>  
 Syllables . . . . . 1834<sup>b</sup>  
 Syntax of verb . . . . . 1835<sup>a</sup>  
 of Text of the OT . . . . . 2957<sup>b</sup> (Weir)  
 Trilateral roots . . . . . 1834<sup>b</sup>  
 Uniformity of Hebrew . 1833<sup>a</sup>  
 Vowels and consonants 1834<sup>a</sup>
- Lantern . . . . . 1836<sup>b</sup>  
 of Torch . . . . . 2999<sup>b</sup>
- Laodicea . . . . . 1836<sup>b</sup> (Banks)  
 Laodiceans, Epistle to the 1836<sup>b</sup> (Rutherford)  
 of Apocryphal Epistles 194<sup>b</sup> (J. M. Wilson)  
 Evidence favoring  
 Ephesians . . . . . 1837<sup>b</sup>  
 Jewish character of  
 church in Ephesus . 1838<sup>a</sup>  
 Laodicea displaced by  
 Ephesus . . . . . 1838<sup>b</sup>  
 Marcion's opinion . . . . . 1837<sup>b</sup>  
 Paul's reference to . . . . . 1837<sup>a</sup>  
 Purpose of the Epistle 1830<sup>a</sup>  
 Similarity of Ephesians  
 and Colossians . . . . . 1838<sup>a</sup>  
 Spurious Epistle . . . . . 1837<sup>a</sup>  
 Testimony in Ephe-  
 sians . . . . . 1837<sup>b</sup>
- Lap . . . . . 1839<sup>a</sup> (Luering)  
 Lapis Assius . . . . . 289<sup>b</sup>  
 Lappidoth . . . . . 1839<sup>b</sup> (Lees)  
 Lapwing . . . . . 1839<sup>b</sup>  
 of Hoopoe . . . . . 1419<sup>a</sup> (Stratton-Porter)
- Larsa . . . . . 365<sup>a</sup> (Clay)  
 Lasciviousness . . . . . 1839<sup>b</sup> (Raffety)  
 Lasea . . . . . 1840<sup>a</sup>  
 of Fair Havens . . . . . 1087<sup>b</sup>
- Lasha . . . . . 1840<sup>a</sup> (Ewing)  
 Lass Sharon . . . . . 1840<sup>a</sup>  
 of Sharon . . . . . 2750<sup>b</sup> (Ewing)
- Last Day . . . . . 799<sup>a</sup> (Orr)  
 Last Days  
 of Eschatology of OT. 972<sup>a</sup> (Orr)  
 Last Time, Times . . . . . 1840<sup>a</sup> (Vos)  
 of Eschatology of NT. 979<sup>b</sup> (Vos)
- Lasthenes . . . . . 1840<sup>b</sup> (Hutchison)  
 Latchet . . . . . 1840<sup>b</sup>
- Latin . . . . . 1840<sup>b</sup> (A. T. Robertson)  
 of Language of the NT 1826<sup>b</sup> (A. T. Robertson)  
 of Latin Version, The  
 Old . . . . . 1841<sup>a</sup> (Nicol)  
 of Roman Empire and  
 Christianity . . . . . 2601<sup>a</sup> (Angus)  
 of Vulgate . . . . . 3058<sup>b</sup> (Angus)
- Latin Version, The Old . 1841<sup>a</sup> (Nicol)  
 Cyprian's Bible . . . . . 1842<sup>a</sup>  
 Individual character-  
 istics . . . . . 1843<sup>a</sup>  
 Later Italic MSS . . . . . 1843<sup>a</sup>  
 Need of translation . . 1841<sup>b</sup>  
 North African use of  
 Latin . . . . . 1842<sup>a</sup>  
 Old Latin MSS . . . . . 1842<sup>b</sup>  
 Possible Eastern origin 1842<sup>b</sup>  
 Prevalence of Greek . . 1842<sup>a</sup>  
 Tertullian's Bible . . . . 1842<sup>b</sup>  
 Value for textual criti-  
 cism . . . . . 1843<sup>a</sup>  
 Versions before Jerome 1841<sup>b</sup>  
 of Vulgate . . . . . 3058<sup>b</sup> (Angus)  
 Work of Jerome . . . . . 1841<sup>b</sup>



- Latter Days  
 of Eschatology of the  
 OT.....972<sup>a</sup> (Orr)
- Lattice  
 of House.....1434<sup>b</sup> (A. C. Dickie)
- Laud.....1843<sup>b</sup>
- Laughing-stock.....1843<sup>b</sup>  
 of Mock.....2072<sup>b</sup> (W. L. Walker)
- Laughter.....1843<sup>b</sup> (W. L. Walker)
- Launch  
 of Ships and Boats... 2774<sup>a</sup> (Nicol)
- Laver.....1843<sup>b</sup> (Caldecott)  
 In the NT.....1844<sup>a</sup>  
 In the tabernacle.... 1843<sup>b</sup>  
 of Tabernacle.....2889<sup>a</sup> (Caldecott; Orr)  
 In the temple.....1844<sup>a</sup>  
 of Temple.....2934<sup>a</sup> (Caldecott; Orr)  
 of Undersetter.....3037<sup>a</sup>
- Law, Judicial.....1858<sup>a</sup> (Hirsch)  
 of Roman Law.....2611<sup>b</sup> (Allen)  
 of Sanhedrin.....2688<sup>b</sup> (Levertoff)
- Law in the NT.....1844<sup>a</sup> (M'Caig)  
 Definition of law.... 1844<sup>b</sup>  
 of Divorce.....865<sup>a</sup> (Caverno)  
 of Forgiveness.....1132<sup>b</sup> (Morro)  
 of Jesus Christ.....1659<sup>b</sup> (Orr)
- Law in the Acts.....1847<sup>a</sup>  
 Peter and Paul.....1847<sup>b</sup>  
 Roman law.....1847<sup>b</sup>  
 Stephen's attitude.. 1847<sup>a</sup>
- Law in the Epistles... 1848<sup>a</sup>  
 Adam and Christ... 1848<sup>b</sup>
- Bondage and  
 freedom.....1850<sup>a</sup>
- Condemnation of  
 law.....1848<sup>a</sup>
- In Corinthians and  
 Philippians.....1850<sup>b</sup>
- Effects of law.....1848<sup>b</sup>
- In Galatians.....1850<sup>a</sup>
- In Hebrews.....1851<sup>a</sup>
- In James.....1851<sup>b</sup>
- Law and righteous-  
 ness.....1848<sup>b</sup>
- Liberty from the law 1849<sup>b</sup>
- In Peter and John,  
 Epistles of.....1852<sup>a</sup>
- Purity of the law... 1849<sup>a</sup>
- Romans, Ep. to... 1848<sup>a</sup>
- Law in the Gospels... 1844<sup>b</sup>  
 Adultery and  
 divorce.....1845<sup>a</sup>
- Answers of Jesus... 1846<sup>a</sup>
- Christ's fulfilment of  
 the law.....1847<sup>a</sup>
- Christ and tradition.1845<sup>a</sup>
- Death of Christ... 1846<sup>b</sup>
- Divisions.....1844<sup>b</sup>
- In Fourth Gospel... 1846<sup>a</sup>
- In life of Jesus... 1846<sup>a</sup>
- Love and hatred... 1845<sup>b</sup>
- Murder.....1845<sup>a</sup>
- Law in the NT—*continued*
- Law in the Gospels—*continued*
- Oaths.....1845<sup>a</sup>  
 of Punishments... 2504<sup>b</sup> (Hirsch)  
 Retaliation.....1845<sup>b</sup>  
 Sabbath.....1845<sup>b</sup>  
 Sermon on Mount.. 1844<sup>b</sup>  
 Teaching of Christ.. 1844<sup>b</sup>  
 of Wrath.....3113<sup>a</sup> (W. Evans)
- Law in the OT.....1852<sup>a</sup> (Rule)  
 Abolition of the law.. 1857<sup>b</sup>  
 Book of Covenant... 1854<sup>a</sup>  
 Ceremonies.....1856<sup>b</sup>  
 Character and design. 1855<sup>b</sup>  
 Comparison with code  
 of Hammurabi... 1854<sup>a</sup>  
 of Covenant, Book of. 729<sup>b</sup> (Mack)  
 Critical views.....1853<sup>a</sup>  
 Dates and codes... 1853<sup>a</sup>  
 Deuteronomic law... 1854<sup>b</sup>  
 Final compilation... 1855<sup>b</sup>  
 Groups of laws.....1853<sup>b</sup>  
 High honor accorded. 2705<sup>b</sup> (Hirsch)  
 Later interpolations.. 1853<sup>b</sup>  
 Law of holiness.....1855<sup>a</sup>  
 Levitical ritual.....1857<sup>a</sup>  
 Limits of discussion.. 1852<sup>a</sup>  
 Marriage.....1856<sup>a</sup>  
 Moses.....2089<sup>b</sup>; 2090<sup>a</sup> (Kyle)  
 of Pentateuch.....2298<sup>a</sup> (Wiener)  
 Punishments.....1856<sup>a</sup>  
 Sabbaths and feasts.. 1856<sup>b</sup>  
 Sacrifices, origin of.. 1856<sup>b</sup>  
 Servants and poor... 1856<sup>a</sup>  
 Terms used.....1852<sup>a</sup>  
 of Torah.....2581<sup>b</sup> (Warfield)  
 Value of the law.... 1857<sup>b</sup>  
 Written law.....1852<sup>b</sup>
- Law, Roman.....2611<sup>b</sup> (Allen)
- Lawful.....1858<sup>a</sup> (W. Evans)
- Lawgiver.....1858<sup>b</sup> (Morro)
- Lawless.....1859<sup>a</sup> (W. Evans)
- Lawyer.....1859<sup>a</sup> (Hirsch)  
 Adviser.....1859<sup>b</sup>  
 Schools of law.....1859<sup>a</sup>  
 of Scribes.....2704<sup>b</sup> (Hirsch)  
 Students of the law.. 1859<sup>a</sup>  
 Teacher of law.....1859<sup>b</sup>
- Lay, Laying.....1859<sup>b</sup> (Breslich)
- Lazarus.....1860<sup>a</sup> (Trever)  
 Critical views of the  
 miracle.....1860<sup>b</sup>  
 Raising of.....1860<sup>a</sup>
- Leach  
 of Horseleach.....1424<sup>a</sup> (Day)
- Lead.....1861<sup>a</sup> (Patch)  
 of Metals.....2044<sup>a</sup> (Patch)  
 of Refiner.....2545<sup>a</sup> (Patch)
- Leaf, Leaves.....1861<sup>b</sup> (M. O. Evans)
- League  
 of Confederacy.....699<sup>a</sup> (W. L. Walker)
- Leah.....1861<sup>b</sup> (Baur)

- Leannoth  
 of Psalms, Book of . . . 2487<sup>a</sup> (Sampey)
- Leaping  
 of Games . . . . . 1168<sup>b</sup> (Smith)
- Leasing . . . . . 1862<sup>a</sup> (W. Evans)
- Leather  
 of Skin . . . . . 2813<sup>b</sup> (Luering)  
 of Tanner . . . . . 2909<sup>a</sup> (Patch)
- Leaven . . . . . 1862<sup>a</sup> (Eager)  
 of Bread . . . . . 514<sup>b</sup> (Eager)  
 of Meals, Meal-time . . . 2014<sup>a</sup> (Eager)
- Lebana, Lebanah . . . . . 1862<sup>b</sup>
- Lebanon . . . . . 1862<sup>b</sup> (Wright)  
 Anti-Lebanon . . . . . 1864<sup>a</sup>  
 of Arabah . . . . . 211<sup>b</sup> (Wright)  
 General features . . . . . 1862<sup>b</sup>  
 Geology of . . . . . 1863<sup>b</sup>  
 History . . . . . 1864<sup>a</sup>  
 of Jordan, Valley of . . . 1735<sup>a</sup> (Wright)  
 Name . . . . . 1862<sup>b</sup>  
 Rivers of . . . . . 1863<sup>a</sup>  
 Scenery . . . . . 1863<sup>b</sup>  
 of Syria . . . . . 2881<sup>a</sup> (Christie)  
 of Tower of Lebanon . . . 3000<sup>b</sup> (Christie)  
 View from . . . . . 1863<sup>a</sup>
- Lebaoth . . . . . 1864<sup>a</sup>
- Lebbaeus . . . . . 1864<sup>a</sup>  
 of Judas . . . . . 1765<sup>a</sup> (S. F. Hunter)  
 of Thaddaeus . . . . . 2964<sup>a</sup> (Kerr)
- Lebonah . . . . . 1864<sup>a</sup>
- Lecah . . . . . 1864<sup>b</sup>
- Ledge . . . . . 1864<sup>b</sup>  
 of Altar . . . . . 106<sup>b</sup> (Wiener)  
 of Temple . . . . . 2930<sup>a</sup> (Caldecott; Orr)
- Leeks . . . . . 1864<sup>b</sup>; 1122<sup>a</sup> (Eager)
- Lees  
 of Wine, Wine Press . . . 3086<sup>a</sup> (Easton)
- Left . . . . . 1864<sup>b</sup> (Luering)  
 of Lefthanded . . . . . 1865<sup>a</sup> (Luering)
- Lefthanded . . . . . 1865<sup>a</sup> (Luering)  
 of Left . . . . . 1864<sup>b</sup> (Luering)
- Leg . . . . . 1865<sup>a</sup> (Luering)  
 of Loins . . . . . 1917<sup>a</sup> (Luering)  
 of Thigh . . . . . 2972<sup>b</sup> (Easton)
- Legendary Apocryphal  
 Gospels . . . . . 198<sup>a</sup> (Hutchison)
- Legions, Roman . . . . . 257<sup>b</sup> (Allen)
- Legislation of Sanctity  
 of Astronomy . . . . . 300<sup>b</sup> (Maunder)
- Legumes . . . . . 1122<sup>a</sup> (Eager)
- Lehabim . . . . . 1865<sup>b</sup>  
 of Lubim . . . . . 1934<sup>b</sup>
- Lehi  
 of Ramath-lehi . . . . . 2528<sup>b</sup> (Ewing)
- Lemuel . . . . . 1865<sup>b</sup> (Genung)  
 of Proverbs, Book of . . . 2473<sup>b</sup> (Genung)
- Lend, Loan . . . . . 1865<sup>b</sup> (Williams)
- Lentils . . . . . 1866<sup>a</sup> (Masterman); 1122<sup>a</sup>  
 (Eager)
- Leopard . . . . . 1866<sup>b</sup> (Day)  
 of Beth-nimrah . . . . . 450<sup>b</sup> (Wright)  
 of Nimrah . . . . . 2147<sup>a</sup> (Ewing)
- Leopard—*continued*  
 of Nimrim . . . . . 2147<sup>a</sup> (Ewing)  
 of Spot, Spotted . . . . . 2846<sup>b</sup> (Macalister)
- Leper . . . . . 1867<sup>a</sup> (Macalister)  
 of Uncleanness . . . . . 3036<sup>b</sup> (Williams)
- Leprosy . . . . . 1867<sup>a</sup> (Macalister)  
 Description . . . . . 1867<sup>a</sup>  
 of Freckled Spot . . . . . 1145<sup>a</sup>  
 In garments . . . . . 1867<sup>b</sup>  
 In houses . . . . . 1868<sup>a</sup>  
 Law regarding . . . . . 1868<sup>a</sup>  
 Localities . . . . . 1867<sup>b</sup>  
 Nature of . . . . . 1867<sup>b</sup>  
 In NT . . . . . 1867<sup>b</sup>  
 In OT . . . . . 1867<sup>a</sup>  
 of Purity . . . . . 2507<sup>b</sup> (Caverno)  
 of Spot, Spotted . . . . . 2846<sup>b</sup> (Macalister)  
 of Tetter . . . . . 2950<sup>a</sup>
- Leshem  
 of Laish . . . . . 1821<sup>b</sup>
- Lessau . . . . . 1868<sup>a</sup>  
 of Adasa . . . . . 54<sup>b</sup>
- Let . . . . . 1868<sup>a</sup>
- Lethech . . . . . 1868<sup>b</sup>  
 of Weights and Measures . . . . . 3079<sup>a</sup> (Porter)
- Letter, Letters  
 of Alphabet . . . . . 103<sup>b</sup> (Richardson)  
 of Epistle . . . . . 966<sup>a</sup> (Pratt)  
 of Palestine . . . . . 2216<sup>b</sup> (Conder)  
 of Palestine, Recent  
 Exploration . . . . . 2228<sup>b</sup> (Cobern)  
 of Tell el-Amarna . . . . . 2927<sup>b</sup> (Kyle)  
 of Writing . . . . . 3114<sup>a</sup> (Richardson)
- Letushim . . . . . 1868<sup>b</sup>  
 of Leummim . . . . . 1868<sup>b</sup>
- Leummim . . . . . 1868<sup>b</sup>  
 of Letushim . . . . . 1868<sup>b</sup>
- Levi (general) . . . . . 1868<sup>b</sup>  
 of Matthew . . . . . 2009<sup>a</sup> (Schodde)
- Levi (patriarch) . . . . . 1868<sup>b</sup> (Ewing)  
 of Priests and Levites . . . 2446<sup>b</sup> (Wiener)
- Leviathan . . . . . 1868<sup>b</sup> (Day)  
 of Astronomy . . . . . 300<sup>b</sup> (Maunder)  
 of Jaw . . . . . 1572<sup>a</sup> (M. O. Evans)  
 of Job, Book of . . . . . 1685<sup>a</sup> (Genung)  
 of Reptile . . . . . 2561<sup>a</sup>  
 of Scales . . . . . 2701<sup>a</sup> (Luering)
- Levirate Law  
 of Marriage . . . . . 1996<sup>b</sup> (Eager)
- Levirate Marriage . . . . . 526<sup>a</sup> (Hirsch)  
 of Husband's Brother . . . 1442<sup>b</sup> (Crannell)
- Levis . . . . . 1869<sup>a</sup>
- Levites  
 of Priests and Levites . . . 2446<sup>b</sup> (Wiener)
- Levitical Cities . . . . . 1869<sup>a</sup> (Wiener)  
 of Agrarian Laws . . . . . 74<sup>a</sup> (Wiener)  
 Doubts as to their  
 existence . . . . . 1869<sup>b</sup>  
 Evidence favorable . . . . . 1869<sup>b</sup>  
 Ezekiel's plan . . . . . 1869<sup>b</sup>  
 Legal provisions . . . . . 1869<sup>a</sup>  
 of Priests and Levites . . . 2446<sup>b</sup> (Wiener)

- Leviticus . . . . . 1870<sup>a</sup> (Möller)  
   Arguments for late date . . . . . 1877<sup>a</sup>  
   Arguments for Mosaic date . . . . . 1878<sup>a</sup>  
   of Atonement, Day of . . . . . 324<sup>b</sup> (Möller)  
   Ceremonial laws . . . . . 1875<sup>a</sup>  
   Character of . . . . . 1870<sup>a</sup>  
   Critical extravagances . . . . . 1872<sup>a</sup>  
   Critical views . . . . . 1871<sup>a</sup>  
   Defense of its integrity . . . . . 1874<sup>a</sup>  
   Dissent from critical opinion . . . . . 1837<sup>a</sup>  
   of Exodus . . . . . 1056<sup>b</sup> (Möller)  
   of Ezekiel . . . . . 1071<sup>a</sup> (Möller)  
   of Genesis . . . . . 1201<sup>a</sup> (Möller)  
   Interpretation of Christianity . . . . . 1880<sup>a</sup>  
   Law of Holiness, the . . . . . 1870<sup>b</sup>  
   Law, imperfection of . . . . . 1880<sup>b</sup>  
   of Moses . . . . . 2089<sup>b</sup> (Kyle)  
   Name . . . . . 1870<sup>a</sup>  
   Origin . . . . . 1877<sup>a</sup>  
   Plan of the book . . . . . 1873<sup>b</sup>  
   Reasons for analysis . . . . . 1872<sup>a</sup>  
   Rejection of critical views . . . . . 1871<sup>b</sup>  
   Significance of . . . . . 1879<sup>b</sup>  
   Structure . . . . . 1871<sup>b</sup>  
   of War . . . . . 3069<sup>b</sup> (Nicol)  
 Lewd, Lewdness . . . . . 1880<sup>b</sup> (Raffety)  
 Libanus  
   of Lebanon . . . . . 1862<sup>b</sup> (Wright)  
 Libation  
   of Sacrifice, OT . . . . . 2638<sup>a</sup> (Reeve)  
 Liberal, Liberality, Liberally . . . . . 1881<sup>a</sup> (Gerberding)  
 Libertines . . . . . 1881<sup>a</sup> (S. F. Hunter)  
   of Rome . . . . . 2621<sup>b</sup> (Allen)  
   Suggestions regarding . . . . . 1881<sup>a</sup>  
   Synagogue of . . . . . 1881<sup>a</sup>  
 Liberty . . . . . 1881<sup>b</sup> (Orr)  
 Libnah . . . . . 1881<sup>b</sup> (Masterman)  
   of Wanderings of Israel . . . . . 3064<sup>a</sup> (Conder)  
 Libni . . . . . 1882<sup>a</sup>  
   of Ladan . . . . . 1821<sup>a</sup>  
 Libnites  
   of Libni . . . . . 1882<sup>a</sup>  
 Libraries . . . . . 1882<sup>a</sup> (Richardson)  
   Amarna collection . . . . . 1883<sup>b</sup>  
   Assyrian libraries . . . . . 1886<sup>b</sup>  
   of Book . . . . . 495<sup>b</sup> (Richardson)  
   Bookcases and buildings . . . . . 1886<sup>a</sup>  
   Book cities . . . . . 1884<sup>a</sup>  
   Dead, libraries for the . . . . . 1882<sup>b</sup>  
   Early literary activity . . . . . 1884<sup>a</sup>  
   Egyptian age . . . . . 1883<sup>a</sup>  
   Exodus, age of the . . . . . 1883<sup>b</sup>  
   Judges, age of . . . . . 1884<sup>a</sup>
- Libraries—*continued*  
   Memory libraries . . . . . 1882<sup>b</sup>  
   Mesopotamian age . . . . . 1882<sup>a</sup>  
   Mythological collections . . . . . 1882<sup>b</sup>  
   NT times . . . . . 1885<sup>b</sup>  
   of Nineveh, Library of . . . . . 2151<sup>a</sup> (Sayce)  
   Non-biblical religious libraries . . . . . 1882<sup>b</sup>  
   Palestine at the conquest . . . . . 1884<sup>a</sup>  
   Patriarchal age . . . . . 1883<sup>a</sup>  
   Prehistoric and primitive collections . . . . . 1882<sup>b</sup>  
   Royal chronicles . . . . . 1885<sup>a</sup>  
   Royal period . . . . . 1884<sup>b</sup>  
   of Writing . . . . . 3123<sup>b</sup> (Richardson)  
 Library  
   Alexandrian . . . . . 456<sup>b</sup> (Dosker)  
   Bible as a . . . . . 1882<sup>a</sup>  
   Definition of . . . . . 1882<sup>a</sup>  
   Natural selection of Bible . . . . . 1882<sup>a</sup>  
   Of Nineveh . . . . . 2151<sup>a</sup> (Sayce)  
   of Writing . . . . . 3119<sup>b</sup> (Richardson)  
 Libya, Libyans . . . . . 1886<sup>b</sup>  
   of Lubim . . . . . 1934<sup>b</sup>  
 Lice . . . . . 1886<sup>b</sup> (Day)  
   of Flea . . . . . 1118<sup>b</sup> (Day)  
   of Gnat . . . . . 1240<sup>a</sup> (Day)  
   of Plagues of Egypt . . . . . 2404<sup>b</sup> (Kyle)  
   of Sand Flies . . . . . 2688<sup>b</sup>  
 Licence . . . . . 1887<sup>a</sup>  
 Lidebir . . . . . 1887<sup>a</sup>  
   of Lo-debar . . . . . 1909<sup>b</sup> (Ewing)  
 Lie, Lying . . . . . 1887<sup>a</sup> (W. Evans)  
   Biblical instances . . . . . 1887<sup>b</sup>  
   of Christs, False . . . . . 628<sup>b</sup> (Orr)  
   Defined . . . . . 1887<sup>a</sup>  
   of False Swearing . . . . . 746<sup>b</sup> (Hirsch)  
   God's attitude toward . . . . . 1887<sup>a</sup>  
   of Oath . . . . . 2172<sup>b</sup> (Levertoff)  
   Penalty for . . . . . 1887<sup>b</sup>  
   of Prophesyings, False . . . . . 2466<sup>b</sup> (Schenk)  
   Racial sin, a . . . . . 1887<sup>a</sup>  
   Words employed . . . . . 1887<sup>b</sup>  
 Liers-in-wait . . . . . 1888<sup>a</sup>  
   of Ambush . . . . . 115<sup>b</sup>  
 Lieutenant  
   of Satrap . . . . . 2697<sup>a</sup>  
 Life . . . . . 1888<sup>a</sup> (Reeve)  
   In Acts . . . . . 1890<sup>a</sup>  
   of Antediluvian Patriarchs . . . . . 139<sup>a</sup> (Davis)  
   Apocryphal ideas . . . . . 1889<sup>a</sup>  
   Capital punishment in OT . . . . . 1889<sup>b</sup>  
   Complexity of idea in OT . . . . . 1888<sup>a</sup>  
   Eternal life in NT . . . . . 1889<sup>a</sup>  
   In Fourth Gospel . . . . . 1889<sup>b</sup>  
   of Immortality . . . . . 1458<sup>b</sup> (Orr)

Life—*continued*

- Johannine ideas . . . . . 1890<sup>a</sup>  
 Long life desired in  
   OT . . . . . 1888<sup>b</sup>  
 In NT . . . . . 1889<sup>a</sup>  
 OT ideas of immortal-  
   ity . . . . . 1888<sup>b</sup>  
 OT teaching . . . . . 1888<sup>a</sup>  
 In Paul's writings . . . . . 1890<sup>a</sup>  
 Popular use in OT . . . . . 1888<sup>a</sup>  
 Relationship with God 1888<sup>b</sup>  
 In Synoptic Gospels . . . . . 1889<sup>a</sup>  
 Terms used . . . . . 1888<sup>a</sup>  
   of Tree of Life . . . . . 3009<sup>a</sup> (Reeve)  
 Lift . . . . . 1890<sup>b</sup> (Easton)  
   of Gate . . . . . 1175<sup>b</sup> (Easton)  
   of Horn . . . . . 1422<sup>a</sup> (Easton)  
 Light . . . . . 1890<sup>b</sup> (Pratt)  
   Attribute of holiness . . . . . 1891<sup>b</sup>  
   Church as . . . . . 1892<sup>a</sup>  
   of Creeds . . . . . 741<sup>a</sup> (Alexander)  
   Figurative use . . . . . 1891<sup>b</sup>  
   of Johannine Theology 1695<sup>b</sup> (Law)  
   of Logos . . . . . 1911<sup>b</sup> (Alexander)  
   Origin of . . . . . 1890<sup>b</sup>  
   Symbolism of . . . . . 1892<sup>a</sup>  
   Various meanings . . . . . 1891<sup>a</sup>  
   of Wisdom . . . . . 3089<sup>a</sup> (Easton)  
 Light, Lightness . . . . . 1892<sup>a</sup> (Orr)  
 Lightning . . . . . 1892<sup>b</sup> (Joy)  
   of Hail . . . . . 1319<sup>b</sup> (Joy)  
   of Thunder . . . . . 2977<sup>a</sup> (Joy)  
 Lign-aloes  
   of Aloes . . . . . 102<sup>b</sup> (Masterman)  
 Ligure  
   of Stones, Precious . . . . . 2856<sup>a</sup> (Fletcher)  
 Like, Liken, Likeness,  
   Liking . . . . . 1892<sup>b</sup> (Easton)  
 Likhi . . . . . 1893<sup>a</sup>  
 Lilith  
   of Night-monster . . . . . 2143<sup>b</sup> (Swcet)  
 Lily . . . . . 1893<sup>a</sup> (Masterman)  
   of Lily-work . . . . . 1893<sup>b</sup>  
   of Lotus Trees . . . . . 1931<sup>b</sup> (Masterman)  
 Lily-work . . . . . 1893<sup>b</sup>  
   of Jachin and Boaz . . . . . 1547<sup>b</sup> (Caldecott)  
   of Lily . . . . . 1893<sup>a</sup> (Masterman)  
 Lime . . . . . 1893<sup>b</sup> (Day)  
   of Chalkstone . . . . . 591<sup>a</sup> (Day)  
   of Clay . . . . . 667<sup>a</sup> (Day)  
   of Rock . . . . . 2596<sup>a</sup> (Day)  
 Limit . . . . . 1894<sup>a</sup>  
 Line . . . . . 1894<sup>a</sup> (Orr)  
   of Measuring Line . . . . . 2016<sup>a</sup> (Porter)  
   of Pencil . . . . . 2298<sup>a</sup>  
   of Rope . . . . . 2623<sup>b</sup> (Easton)  
   of Tools . . . . . 2999<sup>a</sup> (Easton)  
   of Weights and Meas-  
     ures . . . . . 3079<sup>a</sup> (Porter)  
 Lineage . . . . . 1894<sup>a</sup>  
 Linen . . . . . 1894<sup>a</sup> (E. D. Isaacs)  
   of Flax . . . . . 1118<sup>a</sup> (Masterman)

Linen—*continued*

- Garments made of . . . . . 1894<sup>a</sup>  
 History of . . . . . 1894<sup>a</sup>  
   of Silk, Silkworm . . . . . 2790<sup>b</sup> (Day)  
   of Twine . . . . . 3028<sup>a</sup>  
 Lintel  
   of House . . . . . 1434<sup>b</sup> (A. C. Dickie)  
 Linus . . . . . 1894<sup>b</sup> (Rutherford)  
 Lion . . . . . 1895<sup>a</sup> (Day)  
   Figurative use . . . . . 1895<sup>b</sup>  
   Natural history . . . . . 1895<sup>a</sup>  
   References to . . . . . 1895<sup>b</sup>  
   Terms used . . . . . 1895<sup>a</sup>  
   of Whelp . . . . . 3083<sup>a</sup> (Day)  
 Lip . . . . . 1896<sup>a</sup> (Luering)  
   of Mouth . . . . . 2093<sup>a</sup> (Luering)  
 Liquor . . . . . 1896<sup>a</sup>  
   of Drink, Strong . . . . . 879<sup>b</sup> (Edwards)  
   of Wine . . . . . 3086<sup>a</sup> (Easton)  
 List . . . . . 1896<sup>b</sup>  
   of Lust . . . . . 1941<sup>b</sup> (Raffety)  
 Literature, Sub-apostolic 1896<sup>b</sup> (Cowan)  
   of Apocryphal Acts . . . . . 183<sup>b</sup> (A. F. Findlay)  
   of Apocryphal Gospels. 195<sup>a</sup> (Hutchison)  
 Aristides, Apology of . . . . . 1903<sup>a</sup>  
   Church in Athens,  
     the . . . . . 1903<sup>b</sup>  
   Contents . . . . . 1903<sup>a</sup>  
   Notable sayings . . . . . 1903<sup>b</sup>  
   Recovery and date . . . . . 1903<sup>a</sup>  
 Barnabas, Epistle of . . . . . 1901<sup>a</sup>  
   Allegorical method . . . . . 1901<sup>b</sup>  
   Contents and author-  
     ship . . . . . 1901<sup>b</sup>  
   Date . . . . . 1901<sup>b</sup>  
   Notable sayings . . . . . 1902<sup>a</sup>  
   Reference to bap-  
     tism . . . . . 1902<sup>a</sup>  
   Reference to Lord's  
     Day . . . . . 1902<sup>a</sup>  
 Clement to Corin-  
   thians, Epistle of . . . . . 1897<sup>a</sup>  
   Apologetic value . . . . . 1897<sup>b</sup>  
   Authorship and date. 1897<sup>a</sup>  
   Church organiza-  
     tion . . . . . 1897<sup>b</sup>  
   Doctrinal testimony 1897<sup>b</sup>  
   Occasion and con-  
     tents . . . . . 1897<sup>a</sup>  
   Ritual . . . . . 1898<sup>a</sup>  
 Clement, Second  
   Epistle of . . . . . 1902<sup>b</sup>  
   Agrapha of Jesus . . . . . 1903<sup>a</sup>  
   Contents . . . . . 1903<sup>a</sup>  
   Date and author-  
     ship . . . . . 1903<sup>a</sup>  
   Nature of document 1902<sup>b</sup>  
   Notable sayings . . . . . 1903<sup>a</sup>  
 Didache, The . . . . . 1898<sup>a</sup>; 387<sup>b</sup> (A. T. Robert-  
     son)  
   Authorship and ob-  
     ject . . . . . 1898<sup>b</sup>

- Literature, Sub-apostolic—*continued*
- Didache, The—*continued*
- Church officers . . . . . 1899<sup>a</sup>
  - Contents . . . . . 1898<sup>b</sup>
  - Date . . . . . 1898<sup>a</sup>
  - Disappearance and recovery . . . . . 1898<sup>a</sup>
  - Ordinances . . . . . 1898<sup>b</sup>
  - Second advent . . . . . 1899<sup>b</sup>
- Diognetus, Epistle of . . . . . 1904<sup>b</sup>
- Contents . . . . . 1905<sup>a</sup>
  - Date and authorship . . . . . 1904<sup>b</sup>
- cf Gnosticism . . . . . 1240<sup>a</sup> (Rutherford)
- cf Gospels, Synoptic . . . . . 1281<sup>b</sup> (Iverach)
- Hermas, Shepherd of . . . . . 1902<sup>a</sup>
- Authorship and date . . . . . 1902<sup>a</sup>
  - Church officers . . . . . 1902<sup>b</sup>
  - Contents and object . . . . . 1902<sup>b</sup>
  - Notable utterances . . . . . 1902<sup>b</sup>
- Ignatius, Epistle of . . . . . 1899<sup>b</sup>
- Author and date . . . . . 1899<sup>b</sup>
  - Genuineness . . . . . 1899<sup>b</sup>
  - Glory of martyrdom . . . . . 1900<sup>a</sup>
  - Leading ideas . . . . . 1900<sup>a</sup>
  - Notable ideas . . . . . 1900<sup>a</sup>
- cf John, the Apostle . . . . . 1706<sup>b</sup> (Iverach)
- Justin Martyr . . . . . 1903<sup>b</sup>
- Dialogue with Trypho . . . . . 1904<sup>a</sup>
  - First apology . . . . . 1903<sup>b</sup>
  - Life . . . . . 1903<sup>b</sup>
  - Notable sayings . . . . . 1904<sup>a</sup>
  - Reference to Lord's Day . . . . . 1904<sup>a</sup>
  - Second apology . . . . . 1904<sup>a</sup>
- cf Mark, Gospel of . . . . . 1987<sup>b</sup> (Farmer)
- cf Matthew, Gospel of 2009<sup>b</sup> (Schodde)
- Papias Fragments . . . . . 1901<sup>a</sup>
- Author and date . . . . . 1901<sup>a</sup>
  - "John the Presbyter" . . . . . 1901<sup>a</sup>
  - Matthew and Mark mentioned . . . . . 1901<sup>a</sup>
  - Notable statements . . . . . 1901<sup>a</sup>
- cf Peter, Epistles of . . . . . 2351<sup>b</sup> (Moorehead)
- Polycarp, Epistle of . . . . . 1900<sup>b</sup>
- Chief ideas . . . . . 1900<sup>b</sup>
  - Contents and occasion . . . . . 1900<sup>b</sup>
  - Date and genuineness . . . . . 1900<sup>b</sup>
- cf Simon Magus . . . . . 2796<sup>b</sup> (Rutherford)
- cf Spiritual Gifts . . . . . 2843<sup>a</sup> (Lambert)
- cf Trine Immersion . . . . . 3011<sup>b</sup> (Kurtz)
- cf Widow . . . . . 3084<sup>a</sup> (Eager)
- Litter . . . . . 1905<sup>a</sup>
- cf Palanquin . . . . . 2208<sup>a</sup>
- Little Genesis
- cf Book of Jubilees . . . . . 173<sup>a</sup> (J. E. H. Thomson)
- Lively . . . . . 1905<sup>b</sup> (W. L. Walker)
- Liver . . . . . 1905<sup>b</sup> (Luering)
- cf Astrology . . . . . 295<sup>b</sup> (Maunder)
  - cf Caul . . . . . 584<sup>b</sup> (Luering)
  - cf Divination . . . . . 860<sup>a</sup> (T. W. Davies)
- Living . . . . . 1905<sup>b</sup> (W. L. Walker)
- Living Creature . . . . . 1906<sup>a</sup> (Day)
- cf Creature, Living . . . . . 740<sup>b</sup> (W. L. Walker)
- Lizard . . . . . 1906<sup>a</sup> (Day)
- cf Chameleon . . . . . 592<sup>a</sup> (Day)
  - cf Ferret . . . . . 1106<sup>b</sup> (Day)
  - cf Gecko . . . . . 1181<sup>a</sup>
  - cf Land-crocodile . . . . . 1826<sup>b</sup> (Day)
  - cf Mole . . . . . 2074<sup>a</sup> (Day)
  - Names . . . . . 1906<sup>a</sup>
  - In Palestine . . . . . 1906<sup>b</sup>
  - References to, in the Bible . . . . . 1906<sup>b</sup>
  - cf Reptile . . . . . 2561<sup>a</sup>
  - cf Sand-lizard . . . . . 2688<sup>b</sup>
  - cf Snail . . . . . 2819<sup>a</sup> (Day)
  - cf Spider . . . . . 2840<sup>b</sup> (Day)
  - cf Tortoise . . . . . 2999<sup>b</sup> (Day)
  - cf Weasel . . . . . 3076<sup>b</sup> (Day)
- Loaf
- cf Bread . . . . . 514<sup>b</sup> (Eager)
- Lo-ammi . . . . . 1907<sup>a</sup> (Lees)
- cf Hosea . . . . . 1424<sup>b</sup> (J. Robertson)
  - cf Jezreel . . . . . 1677<sup>a</sup> (Ewing)
- Loan . . . . . 1865<sup>b</sup> (Williams)
- Locks . . . . . 1907<sup>a</sup> (Luering)
- Locust . . . . . 1907<sup>b</sup> (Day)
- cf Beetle . . . . . 425<sup>a</sup> (Day)
  - Figurative references . . . . . 1909<sup>a</sup>
  - As food . . . . . 1909<sup>a</sup>
  - cf Food . . . . . 1121<sup>b</sup> (Eager)
  - Grasshopper . . . . . 1908<sup>a</sup>
  - Habits . . . . . 1909<sup>a</sup>
  - Identifications . . . . . 1907<sup>b</sup>
  - cf Insects . . . . . 1473<sup>a</sup> (Day)
  - Names of . . . . . 1907<sup>b</sup>
  - cf Palmer-worm . . . . . 2236<sup>a</sup>
  - cf Plagues of Egypt . . . . . 2405<sup>b</sup> (Kyle)
- Lod, Lydda . . . . . 1909<sup>a</sup> (Ewing)
- Biblical references . . . . . 1909<sup>a</sup>
  - History . . . . . 1909<sup>b</sup>
  - Identification . . . . . 1909<sup>b</sup>
- Loddeus (Saddeus) . . . . . 1909<sup>b</sup>
- Lo-debar . . . . . 1909<sup>b</sup> (Ewing)
- cf Lidebir . . . . . 1887<sup>a</sup>
- Lodge . . . . . 1910<sup>a</sup>
- Loft . . . . . 1910<sup>a</sup>
- Loftily, Loftiness, Lofty . . . . . 1910<sup>a</sup>
- Log . . . . . 1910<sup>a</sup>
- cf Weights and Measures . . . . . 3079<sup>a</sup> (Porter)
- Logia, The . . . . . 1910<sup>a</sup> (Smith)
- cf Agrapha . . . . . 72<sup>a</sup> (Smith)
  - Date . . . . . 1911<sup>a</sup>
  - Description of . . . . . 1910<sup>b</sup>
  - Discovery of . . . . . 1910<sup>a</sup>
  - cf Gospels, Synoptic . . . . . 1281<sup>b</sup> (Iverach)
  - cf Jesus Christ (sources) . . . . . 1626<sup>a</sup> (Orr)

Logia—*continued*

- cf Luke, Gospel of . . . 1939<sup>a</sup> (A. T. Robertson)  
 Meaning of word . . . 1910<sup>a</sup>  
 New sayings of Jesus . . . 1910<sup>b</sup>  
 Old sayings of Jesus . . . 1910<sup>b</sup>  
 Origin and character . . . 1911<sup>a</sup>  
 cf Papyrus . . . . . 2242<sup>a</sup> (Goodspeed)  
 Logos . . . . . 1911<sup>b</sup> (Alexander)  
   Alexandrian synthesis . . . 1913<sup>b</sup>  
   Personality . . . . . 1914<sup>a</sup>  
   Philo . . . . . 1913<sup>b</sup>  
   Special features . . . . . 1913<sup>b</sup>  
   Christian realization . . . 1914<sup>a</sup>  
   In Ep. to Hebrews . . . 1914<sup>b</sup>  
   In Fourth Gospel,  
     doctrine . . . . . 1914<sup>b</sup>  
   In Fourth Gospel,  
     Logos and God . . . 1915<sup>a</sup>  
   In Fourth Gospel,  
     Logos and world . . . 1915<sup>a</sup>  
   In Fourth Gospel,  
     terms used . . . . . 1915<sup>b</sup>  
   Pauline doctrine . . . 1914<sup>a</sup>  
   Philo and John . . . . . 1916<sup>a</sup>  
 cf Doctrine of, in Jo-  
   hannine Theology . . . 1699<sup>a</sup> (Law)  
 Greek speculation . . . 1912<sup>a</sup>  
   Anaxagoras . . . . . 1912<sup>a</sup>  
   Aristotle . . . . . 1912<sup>b</sup>  
   Heraclitus . . . . . 1912<sup>a</sup>  
   Plato . . . . . 1912<sup>a</sup>  
   Stoics . . . . . 1912<sup>b</sup>  
 Hebrew anticipation of  
   doctrine . . . . . 1912<sup>b</sup>  
   Distinctions in Deity . . . 1913<sup>a</sup>  
   Revelation of God . . . 1913<sup>a</sup>  
   Targums . . . . . 1913<sup>a</sup>  
   Theophanies . . . . . 1913<sup>a</sup>  
   Wisdom . . . . . 1913<sup>a</sup>  
 cf John, Gospel of . . . 1720<sup>a</sup> (Iverach)  
   Logos doctrine . . . . . 1725<sup>b</sup>  
 cf Light . . . . . 1891<sup>b</sup> (Pratt)  
   Meaning of term . . . . . 1911<sup>b</sup>  
   cf Mediation . . . . . 2021<sup>a</sup> (Edwards)  
   Patristic development . . . 1916<sup>b</sup>  
   cf Philosophy . . . . . 2384<sup>b</sup> (Rees)  
   cf Platonic Doctrine of . . . 337<sup>b</sup> (Rees)  
   cf Speech . . . . . 2839<sup>b</sup> (W. L. Walker)  
   cf Wisdom of God . . . . . 3092<sup>a</sup> (Easton)  
   cf Wisdom of Solomon . . . 3092<sup>a</sup> (T. W. Davies)  
   cf Word . . . . . 3105<sup>a</sup> (W. L. Walker)  
 Loins . . . . . 1917<sup>a</sup> (Luering)  
   cf Leg . . . . . 1865<sup>a</sup> (Luering)  
   cf Thigh . . . . . 2972<sup>b</sup> (Easton)  
 Lois . . . . . 1917<sup>b</sup> (Rutherford)  
   cf Eunice . . . . . 1037<sup>a</sup> (Rutherford)  
   cf Timothy . . . . . 2983<sup>b</sup> (Rutherford)  
 Longevity . . . . . 1917<sup>b</sup> (Macalister)  
 Longsuffering . . . . . 1918<sup>a</sup> (W. L. Walker)  
   cf Patience . . . . . 2263<sup>b</sup> (W. L. Walker)  
 Look . . . . . 1918<sup>b</sup> (Easton)

- Looking-glass . . . . . 1919<sup>a</sup>  
   cf Glass . . . . . 1233<sup>a</sup> (Porter)  
 Loom  
   cf Weaving . . . . . 3077<sup>a</sup> (Patch)  
 Loop . . . . . 1919<sup>a</sup>  
 Lord of Hosts . . . . . 1919<sup>a</sup>  
   cf God, Names of . . . . . 1264<sup>b</sup> (Mack)  
   cf Host of Heaven . . . . . 1433<sup>b</sup> (Orr)  
   cf War, Man of . . . . . 3072<sup>a</sup>  
 Lord, The Lord . . . . . 1919<sup>a</sup> (Carver)  
   cf God, Names of . . . . . 1264<sup>b</sup> (Mack)  
   cf Keys, Power of . . . . . 1796<sup>a</sup> (Carver)  
   cf Lord's Day . . . . . 1919<sup>a</sup> (Easton)  
 Lord's Day . . . . . 1919<sup>a</sup> (Easton)  
   Change from Sabbath . . . 1920<sup>a</sup>  
   cf Ethics of Jesus . . . . . 1026<sup>a</sup> (Stalker)  
   Later history . . . . . 1920<sup>a</sup>  
   cf Literature, Sub-  
     apost . . . . . 1902<sup>a</sup>; 1904<sup>a</sup> (Cowan)  
   cf Lord, The Lord . . . . . 1919<sup>a</sup> (Carver)  
   Meaning of term . . . . . 1919<sup>a</sup>  
   NT use . . . . . 1919<sup>b</sup>  
   Origin . . . . . 1919<sup>b</sup>  
   Post-apostolic use . . . . . 1919<sup>b</sup>  
   Practical usage . . . . . 1920<sup>a</sup>  
   cf Sabbath . . . . . 2631<sup>a</sup> (Sampey)  
   Sunday and Sabbath . . . 1920<sup>a</sup>  
 Lord's Prayer, The . . . . . 1920<sup>b</sup> (Miller)  
   Arrangement . . . . . 1920<sup>b</sup>  
   cf Church of . . . . . 2188<sup>a</sup> (Masterman)  
   Purpose . . . . . 1921<sup>a</sup>  
   Sources . . . . . 1921<sup>a</sup>  
   Special expressions . . . . . 1921<sup>a</sup>  
   Two forms of . . . . . 1920<sup>b</sup>  
 Lord's Supper (Dunkers) . . . 1928<sup>b</sup> (Kurtz)  
   cf Agape . . . . . 69<sup>b</sup> (Lambert)  
   Church of the Brethren  
     (Dunkers) . . . . . 1928<sup>b</sup>  
     Date . . . . . 1928<sup>b</sup>  
     Love feast, the . . . . . 1929<sup>a</sup>  
     Perpetuation of sup-  
       per . . . . . 1929<sup>a</sup>  
     Practice of Brethren  
       (Dunkers) . . . . . 1929<sup>a</sup>  
 Lord's Supper (general) . . . 1921<sup>b</sup> (Gummey)  
   Definition . . . . . 1921<sup>b</sup>  
   Historical setting . . . . . 1922<sup>b</sup>  
   cf Jesus Christ . . . . . 1658<sup>b</sup> (Orr)  
   cf Johannine Theology . . . 1704<sup>b</sup> (Law)  
   cf Literature, Sub-apost . . . 1904<sup>b</sup> (Cowan)  
   Liturgical tradition . . . . . 1924<sup>a</sup>  
   cf Meals, Meal-time . . . . . 2015<sup>a</sup> (Eager)  
   cf Mediation . . . . . 2022<sup>a</sup> (Edwards)  
   NT narratives . . . . . 1922<sup>a</sup>  
   NT sources . . . . . 1921<sup>b</sup>  
   Observance by the  
     church . . . . . 1923<sup>a</sup>  
   cf Paul, Theology of . . . . . 2292<sup>b</sup> (Easton)  
   Post-apost fathers . . . . . 1923<sup>b</sup>  
   Post-apost usage . . . . . 1923<sup>b</sup>  
   Preparation for the  
     Eucharist . . . . . 1922<sup>a</sup>

- Lord's Supper (general)—*continued*  
   cf Sacraments . . . . . 2636<sup>a</sup> (Lambert)  
   cf Sacrifice, NT . . . . . 2657<sup>b</sup> (Williams)  
   Sequence of the institutions . . . . . 1923<sup>a</sup>  
   cf Washing of Feet . . . . . 3072<sup>b</sup> (Anderson)  
   Words and acts of  
     Jesus . . . . . 1922<sup>b</sup>
- Lord's Supper (historical) . . . . . 1924<sup>b</sup> (Dosker)  
   In apos church . . . . . 1925<sup>a</sup>  
   Calvin . . . . . 1926<sup>b</sup>  
   Derivation . . . . . 1924<sup>b</sup>  
   Elements, the . . . . . 1925<sup>a</sup>  
   Luther . . . . . 1926<sup>a</sup>  
   Original institutions . . . . . 1924<sup>b</sup>  
   Post-apos church . . . . . 1925<sup>b</sup>  
   Roman usage . . . . . 1925<sup>b</sup>  
   Zwingli . . . . . 1926<sup>a</sup>
- Lord's Supper (Lutheran interpretation) . . . . . 1926<sup>b</sup> (Dau)  
   Command of Christ . . . . . 1927<sup>b</sup>  
   Difficulties . . . . . 1928<sup>a</sup>  
   Doctrinal contents of  
     texts . . . . . 1927<sup>a</sup>  
   Elements used . . . . . 1927<sup>b</sup>  
   Eucharistic texts . . . . . 1927<sup>a</sup>  
   Purpose of ordinance . . . . . 1928<sup>a</sup>  
   Source and norm . . . . . 1927<sup>a</sup>  
   Term Eucharist, the . . . . . 1926<sup>b</sup>
- Lords of the Philistines . . . . . 1929<sup>b</sup>  
   cf Philistines . . . . . 2376<sup>b</sup> (Conder)
- Lo-ruhamah  
   cf Lo-ammi . . . . . 1907<sup>a</sup> (Lees)  
   cf Ruhamah . . . . . 2625<sup>b</sup>  
   cf Shear-jashub . . . . . 2752<sup>b</sup>
- Loss . . . . . 1929<sup>b</sup> (Williams)
- Lot  
   cf Divination . . . . . 860<sup>a</sup> (T. W. Davies)  
   cf Pension . . . . . 2298<sup>a</sup>
- Lot (person) . . . . . 1929<sup>b</sup> (Boyd); 18<sup>b</sup> (Boyd)  
   Critical views . . . . . 1931<sup>a</sup>  
   Early career . . . . . 1930<sup>a</sup>  
   Later Biblical references . . . . . 1931<sup>a</sup>  
   Later period . . . . . 1930<sup>b</sup>  
   Personality . . . . . 1929<sup>b</sup>  
   Relations with Abraham . . . . . 1930<sup>a</sup>  
   Wife . . . . . 1931<sup>a</sup>
- Lotan . . . . . 1931<sup>b</sup>  
 Lothasubus . . . . . 1931<sup>b</sup>
- Lots  
   cf Divination . . . . . 860<sup>a</sup> (T. W. Davies)
- Lots, Feast of  
   cf Purim . . . . . 2506<sup>b</sup> (Mack)
- Lotus Trees . . . . . 1931<sup>b</sup> (Masterman)  
   cf Lily . . . . . 1893<sup>a</sup> (Masterman)
- Love . . . . . 1931<sup>b</sup> (W. Evans)  
   Biblical references . . . . . 1931<sup>b</sup>  
   Definition . . . . . 1932<sup>a</sup>  
   God's love . . . . . 1932<sup>a</sup>
- Love—*continued*  
   God's love; objects . . . . . 1932<sup>a</sup>  
   Human love; manner . . . . . 1933<sup>b</sup>  
   Human love; objects . . . . . 1933<sup>a</sup>  
   Human love; source . . . . . 1933<sup>a</sup>
- Love, Brotherly . . . . . 525<sup>b</sup> (Rees)
- Love-feast  
   cf Agape . . . . . 69<sup>b</sup> (Lambert)
- Lovely . . . . . 1934<sup>a</sup> (W. L. Walker)
- Lover . . . . . 1934<sup>a</sup> (W. L. Walker)
- Loves . . . . . 1934<sup>a</sup>  
   cf Psalms, Book of . . . . . 2487<sup>a</sup> (Sampey)
- Lovingkindness . . . . . 1934<sup>a</sup> (W. L. Walker)  
   cf Brotherly Love . . . . . 525<sup>b</sup> (Rees)  
   cf Goodness . . . . . 1279<sup>a</sup> (W. L. Walker)  
   cf Kindness . . . . . 1799<sup>a</sup> (W. L. Walker)  
   cf Mercy . . . . . 2035<sup>b</sup> (W. L. Walker)
- Low Country  
   cf Shephelah . . . . . 2762<sup>a</sup> (Ewing)
- Lowland . . . . . 1934<sup>b</sup> (Day)  
   cf Natural Features . . . . . 2122<sup>a</sup> (Day)  
   cf Shephelah . . . . . 2762<sup>a</sup> (Ewing)  
   cf Vale . . . . . 3045<sup>a</sup> (Day)
- Lozon . . . . . 1934<sup>b</sup>
- Lubim . . . . . 1934<sup>b</sup>  
   cf Lehabim . . . . . 1865<sup>b</sup>  
   cf Libya . . . . . 1886<sup>b</sup>  
   cf Shishak . . . . . 2777<sup>b</sup> (Nicol)
- Lucas (Luke) . . . . . 1934<sup>b</sup>
- Lucian  
   cf Septuagint . . . . . 2727<sup>a</sup> (Thackeray)
- Lucifer . . . . . 1934<sup>b</sup>  
   cf Astrology . . . . . 295<sup>b</sup> (Mauder)
- Lucius . . . . . 1935<sup>a</sup> (S. F. Hunter)  
   cf Numenius . . . . . 2170<sup>a</sup> (Angus)
- Lucius (Roman) . . . . . 1934<sup>b</sup> (Hutchison)
- Lucre . . . . . 1935<sup>a</sup>
- Lud, Ludim . . . . . 1935<sup>a</sup> (Pinches)  
   Egyptian Lud . . . . . 1935<sup>b</sup>  
   cf Lydia . . . . . 1943<sup>a</sup> (Banks)  
   Semitic Lud . . . . . 1935<sup>a</sup>  
   Two different peoples . . . . . 1935<sup>a</sup>
- Luhith, Ascent of . . . . . 1935<sup>b</sup> (Ewing)
- Luke  
   cf Lucas . . . . . 1934<sup>b</sup>
- Luke, The Evangelist . . . . . 1935<sup>b</sup> (A. T. Robertson)  
   cf Acts of Apostles . . . . . 39<sup>a</sup> (A. T. Robertson)  
   Author of Acts and  
     Luke . . . . . 1936<sup>b</sup>  
   Brother of Titus . . . . . 1936<sup>b</sup>  
   Gentile . . . . . 1936<sup>a</sup>  
   Home . . . . . 1936<sup>a</sup>  
   Name . . . . . 1935<sup>b</sup>  
   NT references . . . . . 1936<sup>a</sup>  
   Painter . . . . . 1936<sup>b</sup>  
   Physician . . . . . 1936<sup>a</sup>  
   Relations with Paul . . . . . 1936<sup>b</sup>
- Luke, The Gospel of . . . . . 1936<sup>b</sup> (A. T. Robertson)  
   cf Acts of Apostles . . . . . 39<sup>a</sup> (A. T. Robertson)  
   Analysis . . . . . 1941<sup>a</sup>  
   Authorship . . . . . 1937<sup>b</sup>  
   Canonicity . . . . . 1937<sup>a</sup>

- Luke, The Gospel of—*continued*  
   Characteristics . . . . . 1940<sup>b</sup>  
   Credibility . . . . . 1940<sup>a</sup>  
   Date . . . . . 1940<sup>b</sup>  
   Genuineness . . . . . 1938<sup>a</sup>  
   of Gospels, Synoptic . . . . . 1281<sup>b</sup> (Iverach)  
   Infancy narrative . . . . . 1938<sup>b</sup>  
   Literary style . . . . . 1831<sup>b</sup> (A. T. Robertson)  
   Logia, the . . . . . 1939<sup>a</sup>  
   Luke's method . . . . . 1938<sup>a</sup>  
   Relations to Gospel of  
     Mark . . . . . 1939<sup>a</sup>  
   Sources . . . . . 1938<sup>a</sup>  
   Text . . . . . 1936<sup>a</sup>  
 Lunatic . . . . . 1941<sup>b</sup> (Sweet)  
   of Mad, Madness . . . . . 1960<sup>b</sup> (Macalister)  
   of Night-monster . . . . . 2143<sup>b</sup> (Sweet)  
 Lurk, Lurking-place . . . . . 1941<sup>b</sup>  
 Lust . . . . . 1941<sup>b</sup> (Raffety)  
   of List . . . . . 1896<sup>b</sup>  
   NT usage . . . . . 1942<sup>a</sup>  
   OT usage . . . . . 1942<sup>a</sup>  
 Lute . . . . . 1942<sup>a</sup>  
   of Music . . . . . 2094<sup>b</sup> (Millar)  
 Luther  
   Doctrine of justification . . . . . 1787<sup>a</sup> (Faulkner)  
   of Lord's Supper (historical) . . . . . 1926<sup>a</sup> (Dosker)  
 Luz . . . . . 1942<sup>a</sup> (Ewing)  
 Lycaonia . . . . . 1942<sup>b</sup> (Calder)  
   of Derbe . . . . . 830<sup>b</sup> (Calder)  
   of Iconium . . . . . 1446<sup>b</sup> (Calder)  
   of Lystra . . . . . 1944<sup>a</sup> (Calder)  
 Lycia . . . . . 1943<sup>a</sup> (Banks)  
   of Phaselis . . . . . 2365<sup>b</sup> (Banks)  
 Lydda  
   of Lod . . . . . 1909<sup>a</sup> (Ewing)  
 Lydia (country) . . . . . 1943<sup>a</sup> (Banks)  
   of Asia . . . . . 272<sup>b</sup> (Banks)  
   of Lud, Ludim . . . . . 1935<sup>a</sup> (Pinches)  
   of Philippi . . . . . 2369<sup>a</sup> (Tod)  
 Lydia (person) . . . . . 1943<sup>b</sup> (S. F. Hunter)  
 Lydian  
   of Lydia . . . . . 1943<sup>a</sup> (Banks)  
 Lydians and Asia Minor 274<sup>b</sup> (Calder)  
 Lye  
   of Nitre . . . . . 2153<sup>a</sup> (Patch)  
 Lying . . . . . 1887<sup>a</sup> (W. Evans)  
   of Christs, False . . . . . 628<sup>b</sup> (Orr)  
   of False Swearing . . . . . 746<sup>b</sup> (Hirsch)  
   of Oath . . . . . 2172<sup>b</sup> (Levertoff)  
   of Prophesyings, False 2466<sup>b</sup> (Schenk)  
 Lysanias . . . . . 1943<sup>b</sup> (Kerr)  
   of Abilene . . . . . 11<sup>a</sup> (C. H. Thomson)  
 Lysias . . . . . 1943<sup>b</sup> (Hutchison)  
   of Claudius Lysias . . . . . 666<sup>b</sup> (Kerr)  
   of Gallio . . . . . 1167<sup>b</sup> (Kerr)  
 Lysimachus . . . . . 1944<sup>a</sup> (Hutchison)  
   of Esther, The Rest of 1009<sup>b</sup> (T. W. Davies)  
   of Robbers of Temples 2595<sup>b</sup>  
 Lystra . . . . . 1944<sup>a</sup> (Calder)  
   of Antioch . . . . . 156<sup>b</sup> (Calder)  
   Character and site . . . . . 1944<sup>a</sup>  
   of Iconium . . . . . 1446<sup>b</sup> (Calder)  
   of Lycaonia . . . . . 1942<sup>b</sup> (Calder)  
   Paul and Barnabas at 1944<sup>b</sup>  
   Religion of . . . . . 1944<sup>b</sup>  
 Maacah, Maachah (persons) . . . . . 1945<sup>a</sup> (Ewing); 10<sup>b</sup>  
   (Beecher)  
   of Micaiah . . . . . 2047<sup>a</sup> (Lees)  
   of Tamar . . . . . 2907<sup>b</sup> (Orr)  
 Maacah (place) . . . . . 1945<sup>a</sup> (Ewing)  
   of Maacathites . . . . . 1945<sup>a</sup>  
 Maacathites . . . . . 1945<sup>a</sup>  
 Maachathites  
   of Maacah (place) . . . . . 1945<sup>a</sup> (Ewing)  
 Maadai . . . . . 1945<sup>b</sup>  
 Maadiah (Moadiah) . . . . . 1945<sup>b</sup>  
 Maai . . . . . 1945<sup>b</sup>  
 Maaleh-acrabbim . . . . . 1945<sup>b</sup>  
   of Akrabbim . . . . . 89<sup>a</sup>  
 Maani . . . . . 1945<sup>b</sup>  
   of Meani . . . . . 2016<sup>a</sup>  
 Maarath . . . . . 1945<sup>b</sup>  
 Maareh-geba . . . . . 1945<sup>b</sup> (Ewing)  
 Maasai (Maasiai) . . . . . 1945<sup>b</sup>  
 Maaseas (Mahseiah) . . . . . 1945<sup>b</sup>  
 Maaseiah . . . . . 1945<sup>b</sup> (Lees)  
   of Mahseiah . . . . . 1967<sup>a</sup>  
   of Moossias . . . . . 2081<sup>b</sup>  
 Maaseiah (Baaseiah) . . . . . 1946<sup>a</sup>  
 Maaseiah (Massias) . . . . . 2007<sup>b</sup>  
   of Manes . . . . . 1981<sup>a</sup>  
   of Mathelas . . . . . 2008<sup>a</sup>  
 Maasai  
   of Maasai . . . . . 1945<sup>b</sup>  
 Maasmas . . . . . 1946<sup>a</sup>  
   of Shemaiah . . . . . 2759<sup>a</sup> (Wolf)  
 Maath . . . . . 1946<sup>a</sup>  
 Maaz . . . . . 1946<sup>a</sup>  
 Maaziah . . . . . 1946<sup>a</sup>  
 Mabdai  
   of Mamdai . . . . . 1972<sup>b</sup>  
 Mabnabedai . . . . . 1946<sup>a</sup>  
   of Machnabedai . . . . . 1959<sup>b</sup>  
 Macalon . . . . . 1946<sup>a</sup>  
   of Michmas . . . . . 2048<sup>a</sup>  
 Maccabaeus, Maccabees 1946<sup>a</sup> (Hutchison); 283<sup>a</sup>  
   (Dosker)  
   Antiochus Epiphanes . . . . . 1946<sup>b</sup>  
   of Architecture . . . . . 237<sup>b</sup> (A. C. Dickie)  
   of Aristobulus . . . . . 241<sup>b</sup> (M. O. Evans)  
   of Asmoneans . . . . . 283<sup>a</sup> (Dosker)  
   of Between the Testaments . . . . . 455<sup>a</sup> (Dosker)  
   of Hasidaeans . . . . . 1342<sup>b</sup> (Hutchison)  
   of Hyrcanus . . . . . 1445<sup>b</sup>  
   John and Eleazar . . . . . 1947<sup>a</sup>  
   John Hyrcanus . . . . . 1947<sup>a</sup>  
   Jonathan . . . . . 1947<sup>a</sup>



Maccabaeus, Maccabees—*continued*

- Judas . . . . . 1949<sup>a</sup>; 1765<sup>a</sup> (Hutchison)  
 of Jerusalem . . . . . 1617<sup>b</sup> (Masterman)  
 of Lacedaemonians . . . . . 1819<sup>b</sup> (Hutchison)  
 cf Maccabees, Books  
 of . . . . . 1947<sup>b</sup> (T. W. Davies)  
 Mattathias . . . . . 1946<sup>b</sup>; 2008<sup>b</sup> (Angus)  
 cf Modin . . . . . 2073<sup>a</sup> (Ewing)  
 Name . . . . . 1946<sup>a</sup>  
 Palestine under the  
 Maccabees . . . . . 1946<sup>b</sup>  
 Palestine under Syria . . . . . 1946<sup>b</sup>  
 Simon . . . . . 1947<sup>a</sup>; 2794<sup>b</sup> (Angus)  
 of Sparta, Spartans . . . . . 2839<sup>b</sup> (Orr)  
 cf Temple . . . . . 2936<sup>b</sup> (Caldecott; Orr)  
 cf Tryphon . . . . . 3027<sup>a</sup> (Angus)  
 Maccabees, Books of . . . . . 1947<sup>b</sup> (T. W. Davies)  
 cf Apocrypha . . . . . 178<sup>b</sup> (T. W. Davies)  
 cf Asmoneans . . . . . 283<sup>a</sup> (Dosker)  
 1 Maccabees . . . . . 1947<sup>b</sup>  
 Canonicity . . . . . 1948<sup>a</sup>  
 Contents . . . . . 1948<sup>a</sup>  
 Date . . . . . 1949<sup>b</sup>  
 Historicity . . . . . 1948<sup>b</sup>  
 Name . . . . . 1947<sup>b</sup>  
 Official letters . . . . . 1948<sup>b</sup>  
 Original language . . . . . 1950<sup>a</sup>  
 Prayers and speeches . . . . . 1948<sup>b</sup>  
 Sources . . . . . 1950<sup>a</sup>  
 Standpoint and aim . . . . . 1949<sup>a</sup>  
 Text and versions . . . . . 1950<sup>b</sup>  
 2 Maccabees . . . . . 1950<sup>b</sup>  
 Author . . . . . 1953<sup>a</sup>  
 Contents . . . . . 1950<sup>b</sup>  
 Date . . . . . 1953<sup>a</sup>  
 Historicity . . . . . 1951<sup>b</sup>  
 Name and canonicity . . . . . 1950<sup>b</sup>  
 Official documents . . . . . 1951<sup>b</sup>  
 Original language . . . . . 1953<sup>a</sup>  
 Pharisaic standpoint . . . . . 1951<sup>b</sup>  
 Sources . . . . . 1951<sup>a</sup>  
 Teachings . . . . . 1952<sup>a</sup>  
 3 Maccabees . . . . . 1953<sup>b</sup>  
 Canonicity . . . . . 1953<sup>b</sup>  
 Contents . . . . . 1953<sup>b</sup>  
 Date and authorship . . . . . 1954<sup>b</sup>  
 Historicity . . . . . 1954<sup>a</sup>  
 Language and text . . . . . 1954<sup>b</sup>  
 Miraculous deliverances of Jesus . . . . . 1953<sup>b</sup>  
 Name . . . . . 1953<sup>b</sup>  
 Teaching and aim . . . . . 1954<sup>b</sup>  
 4 Maccabees . . . . . 1954<sup>b</sup>  
 Canonicity and contents . . . . . 1955<sup>a</sup>  
 Date and authorship . . . . . 1955<sup>a</sup>  
 Language and text . . . . . 1955<sup>b</sup>  
 Name . . . . . 1954<sup>b</sup>  
 Teachings . . . . . 1955<sup>a</sup>

Maccabees, Books of—*continued*

- 5 Maccabees . . . . . 1955<sup>b</sup>  
 Canonicity and contents . . . . . 1955<sup>b</sup>  
 Date and authorship . . . . . 1956<sup>a</sup>  
 Historicity . . . . . 1956<sup>a</sup>  
 Name . . . . . 1955<sup>b</sup>  
 Original language . . . . . 1956<sup>a</sup>  
 Purpose and teaching . . . . . 1956<sup>a</sup>  
 cf Palestine . . . . . 2220<sup>b</sup> (Conder)  
 cf Resurrection . . . . . 2563<sup>b</sup> (Easton)  
 Macedonia . . . . . 1956<sup>a</sup> (Tod)  
 Christians mentioned . . . . . 1959<sup>a</sup>  
 Christian women in . . . . . 1958<sup>b</sup>  
 Church in . . . . . 1958<sup>b</sup>  
 Church characteristics in . . . . . 1958<sup>b</sup>  
 History . . . . . 1956<sup>b</sup>  
 Land and people . . . . . 1956<sup>b</sup>  
 Paul and Macedonia . . . . . 1957<sup>b</sup>  
 Paul's first visit . . . . . 1957<sup>b</sup>  
 Paul's second visit . . . . . 1958<sup>a</sup>  
 Paul's third visit . . . . . 1958<sup>b</sup>  
 Paul's visits later . . . . . 1958<sup>b</sup>  
 Philip and Alexander . . . . . 1957<sup>a</sup>  
 cf Philippi . . . . . 2369<sup>a</sup> (Tod)  
 Roman intervention . . . . . 1957<sup>a</sup>  
 Roman province, a . . . . . 1957<sup>b</sup>  
 Roman times and afterward . . . . . 1957<sup>b</sup>  
 Machaerus . . . . . 1959<sup>a</sup> (Ewing)  
 Machbannai . . . . . 1959<sup>b</sup>  
 Machbena . . . . . 1959<sup>b</sup>  
 cf Cabbon . . . . . 536<sup>a</sup>  
 Machi . . . . . 1959<sup>b</sup>  
 Machir, Machirite . . . . . 1959<sup>b</sup> (Lees)  
 Machmas  
 cf Michmash . . . . . 2048<sup>a</sup> (Ewing)  
 Machnadebai . . . . . 1959<sup>b</sup>  
 Machpelah . . . . . 1959<sup>b</sup> (Masterman)  
 Biblical references . . . . . 1959<sup>b</sup>  
 Cave of . . . . . 1960<sup>b</sup>  
 Cenotaphs of patriarchs . . . . . 1960<sup>a</sup>  
 Haram at Hebron . . . . . 1960<sup>a</sup>  
 cf Hebron . . . . . 1365<sup>a</sup> (Masterman)  
 cf Mamre . . . . . 1973<sup>a</sup> (Masterman)  
 Traditional site . . . . . 1960<sup>a</sup>  
 Visits to . . . . . 1960<sup>a</sup>  
 Maconah  
 cf Meconah . . . . . 2016<sup>b</sup>  
 Macron (Ptolemy) . . . . . 1960<sup>b</sup> (Angus)  
 Mad, Madness . . . . . 1960<sup>b</sup> (Macalister)  
 cf Lunatic . . . . . 1941<sup>b</sup> (Sweet)  
 NT references . . . . . 1961<sup>a</sup>  
 OT references . . . . . 1961<sup>a</sup>  
 Saul's insanity . . . . . 1961<sup>a</sup>  
 Madai  
 cf Medes . . . . . 2017<sup>a</sup> (Tisdall)

- Madeba Mosaic  
   of Palestine, Recent Ex-  
   ploration . . . . . 2225<sup>b</sup> (Cobern)
- Madiabun  
   of Emadabun . . . . . 940<sup>a</sup>
- Madian  
   of Midian . . . . . 2049<sup>a</sup> (Ewing)
- Madmannah . . . . . 1961<sup>b</sup>
- Madmen . . . . . 1961<sup>b</sup>
- Madmenah . . . . . 1961<sup>b</sup>
- Madness . . . . . 1960<sup>b</sup> (Macalister)
- Madon . . . . . 1961<sup>b</sup> (Ewing)
- Maelus . . . . . 1961<sup>b</sup>
- Magadan (Dalmanutha) 1961<sup>b</sup> (Ewing)
- Magbish (Magpiash) . . . 1962<sup>a</sup>
- Magdala  
   of Magadan . . . . . 1961<sup>b</sup> (Ewing)  
   of Palestine . . . . . 2221<sup>b</sup> (Conder)
- Magdalene  
   of Mary . . . . . 2003<sup>b</sup> (Sweet)
- Magdiel . . . . . 1962<sup>a</sup>
- Maged (Maked) . . . . . 1969<sup>a</sup>
- Magi, The . . . . . 1962<sup>a</sup> (Tisdall)  
   of Astrology . . . . . 295<sup>b</sup> (Maunder)  
   of Astronomy . . . . . 300<sup>b</sup> (Maunder)  
   of Divination . . . . . 860<sup>a</sup> (T. W. Davies)  
   of Jesus Christ . . . . . 1633<sup>a</sup> (Orr)  
   Magi at Bethlehem . . . 1962<sup>b</sup>  
   of Magic . . . . . 1963<sup>a</sup> (T. W. Davies)  
   Median tribe . . . . . 1962<sup>a</sup>  
   of Persian Religion . . . 2334<sup>b</sup> (Tisdall)  
   of Wise Men . . . . . 3096<sup>b</sup> (Easton)  
   of Zoroastrianism . . . . 3157<sup>a</sup> (Easton)
- Magi, Star of . . . . . 2848<sup>a</sup> (Maunder)
- Magic, Magician . . . . . 1963<sup>a</sup> (T. W. Davies)  
   of Amulet . . . . . 126<sup>b</sup> (T. W. Davies)  
   In the Bible . . . . . 1963<sup>b</sup>  
   Bible, hostility of, to . . 1963<sup>b</sup>  
   Biblical denunciations  
   of . . . . . 1964<sup>b</sup>  
   Biblical terms . . . . . 1964<sup>a</sup>  
   of Charm . . . . . 597<sup>b</sup> (T. W. Davies)  
   Definition . . . . . 1963<sup>a</sup>  
   of Demonology . . . . . 827<sup>b</sup> (Sweet)  
   of Divination . . . . . 860<sup>a</sup> (T. W. Davies)  
   Divination and sorcery 1964<sup>b</sup>  
   Impersonal magic . . . . . 1963<sup>a</sup>  
   Influence of charms . . . 1964<sup>a</sup>  
   of Jannes and Jambres . 1568<sup>a</sup> (Rutherford)  
   of Magi, The . . . . . 1962<sup>a</sup> (Tisdall)  
   Magical words . . . . . 1964<sup>a</sup>  
   Personal magic . . . . . 1963<sup>b</sup>  
   Religion and . . . . . 1963<sup>b</sup>  
   of Repetitions . . . . . 2559<sup>b</sup> (Easton)  
   Term used . . . . . 1963<sup>a</sup>  
   of Witch, Witchcraft . . 3097<sup>a</sup> (T. W. Davies)
- Magistrate . . . . . 1965<sup>a</sup> (Hirsch)
- Magnifical . . . . . 1965<sup>a</sup>
- Magnificat . . . . . 1965<sup>a</sup>
- Magnify . . . . . 1965<sup>b</sup>
- Magog . . . . . 1965<sup>b</sup>  
   of Gog . . . . . 1273<sup>a</sup> (Reeve)
- Magor-missabib . . . . . 1965<sup>b</sup>
- Magpiash (Magbish) . . . 1962<sup>a</sup>
- Magus, Simon . . . . . 2795<sup>b</sup> (Rutherford)  
   of Magi . . . . . 1962<sup>a</sup> (Tisdall)  
   of Magic . . . . . 1963<sup>a</sup> (T. W. Davies)
- Mahalah (Mahlah) . . . . 1965<sup>b</sup>
- Mahalalel (Mahalaleel) . . 1965<sup>b</sup>; 139<sup>a</sup> (Davis)
- Mahalath . . . . . 1965<sup>b</sup> (Orr)  
   of Basemath . . . . . 411<sup>a</sup> (Breslich)  
   of Psalms, Book of . . . . 2487<sup>a</sup> (Sampey)
- Mahali (Mahli) . . . . . 2081<sup>a</sup>
- Mahanaim (Mahaneh) . . . 1966<sup>a</sup> (Ewing)  
   Jacob at . . . . . 1966<sup>a</sup>  
   Site of . . . . . 1966<sup>a</sup>
- Mahaneh (Mahanaim) . . . 1966<sup>a</sup> (Ewing)  
   Mahaneh-dan . . . . . 1966<sup>b</sup> (Ewing)  
   of Kiriath-jearim . . . . 1811<sup>b</sup> (Masterman)
- Maharai . . . . . 1966<sup>b</sup>
- Mahath . . . . . 1966<sup>b</sup> (Wallace)
- Mahavite . . . . . 1967<sup>a</sup>
- Mahazioth . . . . . 1967<sup>a</sup>
- Maher-shalal-hash-baz . . 1967<sup>a</sup>  
   of Shear-jashub . . . . . 2752<sup>b</sup>
- Mahlah (Mahalah) . . . . 1967<sup>a</sup> (Wallace)
- Mahli (Mahali) . . . . . 1967<sup>a</sup>
- Mahli (Mooli) . . . . . 2081<sup>a</sup>  
   of Mahlites . . . . . 1967<sup>a</sup>  
   of Mahlon . . . . . 1967<sup>a</sup>
- Mahlites  
   of Mahlah . . . . . 1967<sup>a</sup> (Wallace)  
   of Mahli . . . . . 1967<sup>a</sup>
- Mahlon . . . . . 1967<sup>a</sup>  
   of Mahlah . . . . . 1967<sup>a</sup> (Wallace)  
   of Mahli . . . . . 1967<sup>a</sup>
- Mahol . . . . . 1967<sup>a</sup>
- Mahseiah (Maaseas) . . . . 1967<sup>a</sup>  
   of Maaseiah . . . . . 1945<sup>b</sup> (Lees)
- Maiannas . . . . . 1967<sup>a</sup>  
   of Maaseiah . . . . . 1945<sup>b</sup> (Lees)
- Maid, Maiden . . . . . 1967<sup>b</sup> (Pollard)  
   of Girl . . . . . 1232<sup>a</sup>  
   of Virgin . . . . . 3051<sup>b</sup> (Easton)
- Mail . . . . . 1967<sup>b</sup>  
   of Armor, Arms . . . . . 251<sup>a</sup> (Nicol)
- Maimed . . . . . 1967<sup>b</sup> (Macalister)
- Mainsail  
   of Ships and Boats . . . 2774<sup>a</sup> (Nicol)
- Makaz . . . . . 1968<sup>a</sup>
- Make, Maker . . . . . 1968<sup>a</sup> (W. L. Walker)  
   Changes in RV . . . . . 1968<sup>b</sup>  
   NT usage . . . . . 1968<sup>b</sup>  
   OT usage . . . . . 1968<sup>a</sup>
- Makebates . . . . . 1968<sup>b</sup>
- Maked (Maged) . . . . . 1969<sup>a</sup>
- Maker . . . . . 1968<sup>a</sup> (W. L. Walker)
- Makheloth . . . . . 1969<sup>a</sup>  
   of Wanderings of Is-  
   rael . . . . . 3064<sup>a</sup> (Conder)
- Makedah . . . . . 1969<sup>a</sup> (Ewing)
- Maktesh, The . . . . . 1969<sup>a</sup> (Masterman)  
   of Jerusalem . . . . . 1608<sup>a</sup> (Masterman)  
   of Mishneh . . . . . 2066<sup>b</sup> (Masterman)

- Malachi . . . . . 1969<sup>b</sup> (Robinson)  
   Contents . . . . . 1970<sup>a</sup>  
   Message . . . . . 1970<sup>b</sup>  
   cf Messenger . . . . . 2039<sup>a</sup> (Breslich)  
   Name . . . . . 1969<sup>b</sup>  
   Period of . . . . . 1969<sup>b</sup>  
   Style . . . . . 1970<sup>b</sup>  
 Malachy . . . . . 1971<sup>a</sup> (Robinson)  
   cf Malachi . . . . . 1969<sup>b</sup> (Robinson)  
 Malcam (Malcham) . . . . . 1971<sup>a</sup>  
 Malcam (Molech) . . . . . 1971<sup>a</sup>  
 Malcham (Malcam) . . . . . 1971<sup>a</sup>  
 Malchiah (Melchiah) . . . . . 2028<sup>a</sup>  
   cf Malchijah . . . . . 1971<sup>a</sup> (Wallace)  
 Malchiel . . . . . 1971<sup>a</sup>  
 Malchielites . . . . . 1971<sup>a</sup>  
 Malchijah . . . . . 1971<sup>a</sup> (Wallace)  
 Malchiram . . . . . 1971<sup>a</sup>  
 Malchi-shua . . . . . 1971<sup>a</sup>  
 Malchus . . . . . 1971<sup>a</sup> (Kerr)  
 Male . . . . . 1971<sup>b</sup> (Luering)  
   cf Woman . . . . . 3100<sup>a</sup> (Pratt)  
 Malefactor . . . . . 1972<sup>a</sup>  
 Maleleel . . . . . 1972<sup>a</sup>  
 Malice, Malignity . . . . . 1972<sup>a</sup> (W. L. Walker)  
 Malignity . . . . . 1972<sup>a</sup> (W. L. Walker)  
 Mallos  
   cf Mallus . . . . . 1972<sup>a</sup> (Ewing)  
 Mallothi . . . . . 1972<sup>a</sup> (Wallace)  
 Mallows  
   cf Salt-wort . . . . . 2664<sup>b</sup> (Masterman)  
 Malluch . . . . . 1972<sup>a</sup>  
 Malluch (Mamuchus) . . . . . 1974<sup>a</sup>  
 Malluchi . . . . . 1972<sup>a</sup>  
   cf Malluch . . . . . 1972<sup>a</sup>  
 Mallus . . . . . 1972<sup>a</sup> (Ewing)  
 Malobathron (Bethel) . . . . . 1972<sup>b</sup>  
 Maltanneus (Altaneus) . . . . . 1972<sup>b</sup>  
   cf Mattenai . . . . . 2009<sup>a</sup>  
 Mamaias  
   cf Samaias . . . . . 2671<sup>a</sup> (Angus)  
 Mamdai . . . . . 1972<sup>b</sup>  
 Mammon . . . . . 1972<sup>b</sup> (Miller)  
   cf Riches . . . . . 2590<sup>b</sup> (Forrester)  
 Mamnitaneus (Mamni-  
   tanaimus)  
   cf Mattaniah . . . . . 2008<sup>b</sup> (Wallace)  
   cf Mattenai . . . . . 2009<sup>a</sup>  
 Mamre . . . . . 1973<sup>a</sup> (Masterman)  
   Biblical data . . . . . 1973<sup>a</sup>  
   cf Hebron . . . . . 1365<sup>a</sup> (Masterman)  
   cf Machpelah . . . . . 1960<sup>a</sup> (Masterman)  
   Three sites mentioned . . . . . 1973<sup>a</sup>  
   Traditional sites . . . . . 1973<sup>a</sup>  
 Mamuchus (Malluch) . . . . . 1974<sup>a</sup>  
 Man  
   cf Anthropology . . . . . 144<sup>b</sup> (Marais)  
   Antiquity of . . . . . 151<sup>a</sup>  
   Nature of . . . . . 145<sup>b</sup>  
   Origin of . . . . . 146<sup>b</sup>  
   Primitive conditions of . . . . . 150<sup>b</sup>  
   Unity of race . . . . . 147<sup>b</sup>  
 Man, Natural . . . . . 1974<sup>a</sup> (Webb)  
   Biblical meaning . . . . . 1974<sup>a</sup>  
   Carnal man . . . . . 1974<sup>b</sup>  
   cf Man, New . . . . . 1975<sup>a</sup> (Webb)  
   Old man, the . . . . . 1974<sup>a</sup>  
     cf Old Man . . . . . 2183<sup>b</sup> (Pratt)  
   Outward man, the . . . . . 1974<sup>a</sup>  
     cf Outward Man . . . . . 2205<sup>a</sup>  
   cf Regeneration . . . . . 2546<sup>b</sup> (Nuelsen)  
   cf Spiritual . . . . . 2842<sup>b</sup> (Pratt)  
   Theological meaning . . . . . 1974<sup>b</sup>  
 Man, New . . . . . 1975<sup>a</sup> (Webb)  
   Biblical meaning . . . . . 1975<sup>a</sup>  
   Inward man . . . . . 1975<sup>a</sup>  
   cf Man, Natural . . . . . 1974<sup>a</sup> (Webb)  
   cf Old Man . . . . . 2183<sup>b</sup> (Pratt)  
   cf Outward Man . . . . . 2205<sup>a</sup>; 1974<sup>a</sup>  
   Spiritual man . . . . . 1975<sup>a</sup>; 2844<sup>b</sup>  
   Terms used . . . . . 1975<sup>b</sup>  
   Theological meaning . . . . . 1975<sup>b</sup>  
 Man, Old . . . . . 2183<sup>b</sup> (Pratt)  
   cf Man, New . . . . . 1975<sup>a</sup> (Webb)  
 Man, Outward . . . . . 2205<sup>a</sup>  
   cf Man, Natural . . . . . 1974<sup>a</sup> (Webb)  
 Man of Sin . . . . . 1975<sup>b</sup> (Orr)  
   cf Antichrist . . . . . 154<sup>a</sup> (J. E. H. Thomson)  
   cf Belial . . . . . 431<sup>b</sup> (Orr)  
   Essential idea, the . . . . . 1976<sup>b</sup>  
   Pauline description . . . . . 1975<sup>b</sup>  
   cf Perdition . . . . . 2320<sup>a</sup> (Vos)  
   cf Revelation of John . . . . . 2582<sup>b</sup> (Orr)  
   cf Thessalonians . . . . . 2969<sup>a</sup> (R. H. Walker)  
   Varying descriptions . . . . . 1976<sup>a</sup>  
 Man, Son of . . . . . 2828<sup>b</sup> (Stalker)  
 Man of War  
   cf War . . . . . 3069<sup>b</sup> (Nicol)  
 Manaen (Menaem) . . . . . 1976<sup>b</sup> (Orr)  
 Manahath . . . . . 1976<sup>b</sup> (Ewing)  
   cf Menuhah . . . . . 2033<sup>a</sup>  
   cf Menuhoth . . . . . 2033<sup>a</sup> (Wallace)  
   cf Zorites . . . . . 3157<sup>a</sup>  
 Manahathites (Mana-  
   hethites) . . . . . 1977<sup>a</sup>  
 Manasseas . . . . . 1977<sup>a</sup>  
 Manasseh (general) . . . . . 1977<sup>a</sup> (Wallace)  
   cf Pahath-moah . . . . . 2207<sup>a</sup> (Wallace)  
 Manasseh (king) . . . . . 1978<sup>a</sup> (Genung)  
   Character of reign . . . . . 1978<sup>b</sup>  
   cf Hezekiah . . . . . 1385<sup>a</sup> (Genung)  
   Idoltrous conduct . . . . . 1978<sup>b</sup>  
   Journey to Babylon . . . . . 1979<sup>b</sup>  
   cf Manasses, The Prayer  
     of . . . . . 1979<sup>b</sup> (T. W. Davies)  
   Name . . . . . 1978<sup>a</sup>  
   Persecution . . . . . 1979<sup>a</sup>  
   Political situation . . . . . 1978<sup>b</sup>  
   Repentance . . . . . 1979<sup>a</sup>  
   Sources for . . . . . 1978<sup>b</sup>  
 Manasseh (patriarch,  
   tribe, territory) . . . . . 1977<sup>a</sup> (Ewing)  
   Genealogies of . . . . . 1978<sup>a</sup>

- Manasseh (patriarch, tribe, territory)—*continued*  
 History of . . . . . 1978<sup>a</sup>  
 of Israel, History of the  
   People . . . . . 1524<sup>a</sup> (Orelli)  
 of Jehoiachin . . . . . 1577<sup>a</sup> (Genung)  
 Location in Canaan . . . . . 1977<sup>b</sup>  
 Son of Joseph . . . . . 1977<sup>a</sup>  
 Tribe in early period . . . . . 1977<sup>b</sup>
- Manasses . . . . . 1979<sup>a</sup> (Angus)
- Manasses, Prayer of . . . . . 1979<sup>b</sup> (T. W. Davies)  
 Authenticity . . . . . 1980<sup>a</sup>  
 Canonicity . . . . . 1979<sup>b</sup>  
 Contents . . . . . 1980<sup>a</sup>  
 Date . . . . . 1980<sup>b</sup>  
 of Manasseh . . . . . 1977<sup>a</sup> (Wallace)  
 of Manasses . . . . . 1979<sup>a</sup> (Angus)  
 Motive of author . . . . . 1980<sup>b</sup>  
 Name . . . . . 1979<sup>b</sup>  
 Original language . . . . . 1980<sup>a</sup>  
 Probable fiction . . . . . 1980<sup>a</sup>  
 Text and versions . . . . . 1980<sup>b</sup>  
 of Text of OT . . . . . 2957<sup>b</sup> (Weir)
- Manassites . . . . . 1980<sup>b</sup>
- Man-child . . . . . 1980<sup>b</sup>
- Mandrakes . . . . . 1981<sup>a</sup> (Masterman)
- Maneh (Mina) . . . . . 1981<sup>a</sup> (Porter)  
 of Pound . . . . . 2426<sup>b</sup> (Porter)  
 of Weights and Measures . . . . . 3079<sup>a</sup> (Porter)
- Manes . . . . . 1981<sup>a</sup>  
 of Maasciah . . . . . 1945<sup>b</sup> (Lees)
- Manger . . . . . 1981<sup>b</sup> (Orr)
- Mani (Bani) . . . . . 1981<sup>b</sup>
- Manifest, Manifestation . . . . . 1981<sup>b</sup> (W. L. Walker)
- Manifestly . . . . . 1981<sup>b</sup>
- Manifold . . . . . 1981<sup>b</sup> (W. L. Walker)
- Manius, Titus (Manlius,  
 Titus) . . . . . 1982<sup>a</sup> (Angus)  
 of Memmius, Quintus . . . . . 2030<sup>b</sup> (Angus)
- Mankind . . . . . 1982<sup>a</sup>
- Manlius, Titus (Manius,  
 Titus) . . . . . 1982<sup>a</sup> (Angus)
- Manna . . . . . 1982<sup>a</sup> (Masterman)  
 of Moses . . . . . 2087<sup>a</sup> (Kyle)  
 Natural explanations . . . . . 1982<sup>b</sup>  
 NT references . . . . . 1982<sup>b</sup>  
 OT references . . . . . 1982<sup>a</sup>
- Manner, Manners . . . . . 1982<sup>b</sup> (W. L. Walker)  
 Apocryphal use . . . . . 1983<sup>a</sup>  
 NT usage . . . . . 1983<sup>b</sup>  
 OT usage . . . . . 1982<sup>b</sup>
- Manoah . . . . . 1983<sup>b</sup> (Schenk)
- Manservant . . . . . 1983<sup>b</sup>  
 of Servant . . . . . 2738<sup>b</sup> (McGlothlin)  
 of Slave . . . . . 2815<sup>a</sup> (Raffety)
- Mansion . . . . . 1983<sup>b</sup>
- Manslaughter . . . . . 1983<sup>b</sup> (Hirsch)  
 of Murder . . . . . 2094<sup>a</sup> (Hirsch)
- Manslayer . . . . . 1983<sup>b</sup> (Hirsch)  
 of Murder . . . . . 2094<sup>a</sup> (Hirsch)
- Manstealing  
 of Kidnapping . . . . . 1797<sup>b</sup>  
 of Punishments . . . . . 2504<sup>b</sup> (Hirsch)
- Mantelet . . . . . 1984<sup>a</sup>  
 of Siege . . . . . 2786<sup>a</sup> (Nicol)
- Mantle . . . . . 1984<sup>a</sup>  
 of Dress . . . . . 875<sup>b</sup> (Eager)  
 of Kerchief . . . . . 1793<sup>a</sup>
- Manuscripts . . . . . 1984<sup>a</sup> (Richardson)  
 of Book . . . . . 495<sup>b</sup> (Richardson)  
 of Septuagint . . . . . 2722<sup>a</sup> (Thaokeray)  
 of Text and Manuscripts of NT . . . . . 2950<sup>b</sup> (Sitterly)  
 of Versions, Georgian,  
 Gothic, Slavonic . . . . . 3048<sup>a</sup> (Easton)  
 of Writing . . . . . 3114<sup>a</sup> (Richardson); 103<sup>b</sup>  
 (Richardson)
- Manuscripts of the NT  
 of Texts and Manuscripts of NT . . . . . 2950<sup>b</sup> (Sitterly)
- Manuscripts of the OT  
 of Languages of the  
 OT . . . . . 1832<sup>a</sup> (Weir)
- Maoch (Maacah) . . . . . 1984<sup>a</sup>
- Maon, Maonites . . . . . 1984<sup>a</sup> (Ewing)
- Mar . . . . . 1984<sup>b</sup>
- Mara . . . . . 1984<sup>b</sup>
- Marah . . . . . 1984<sup>b</sup>  
 of Wanderings of Israel . . . . . 3064<sup>a</sup> (Conder)
- Maralah . . . . . 1984<sup>b</sup>
- Maranatha . . . . . 1984<sup>b</sup>
- Marble . . . . . 1984<sup>b</sup> (Day)
- March, Marches  
 of War . . . . . 3069<sup>b</sup> (Nicol)
- Marcheshvan  
 of Time . . . . . 2981<sup>b</sup> (Porter)
- Marcion, Gospel of  
 of Apocryphal Gospels . . . . . 197<sup>b</sup> (Hutchison)
- Marcus  
 of Mark . . . . . 1985<sup>b</sup> (Pratt)
- Mardocheus (Mordecai) . . . . . 1985<sup>a</sup>
- Marduk . . . . . 371<sup>b</sup> (Rogers)
- Mare . . . . . 1985<sup>a</sup>  
 of Camel . . . . . 547<sup>b</sup> (Day)  
 of Horse . . . . . 1423<sup>a</sup> (Day)
- Mareshah . . . . . 1985<sup>a</sup> (Ewing)  
 of Palestine, Recent  
 Exploration . . . . . 2227<sup>a</sup> (Cobern)
- Marimoth (Meraioth) . . . . . 1985<sup>b</sup>; 2030<sup>b</sup>  
 of Memeroth . . . . . 2030<sup>b</sup>
- Mariner  
 of Ships and Boats . . . . . 2774<sup>a</sup> (Nicol)
- Marisa . . . . . 1985<sup>b</sup>  
 of Mareshah . . . . . 1985<sup>a</sup> (Ewing)
- Marish . . . . . 1985<sup>b</sup>
- Marissa  
 of Architecture . . . . . 237<sup>b</sup> (A. C. Dickie)
- Mark (noun) . . . . . 1985<sup>b</sup> (Pratt)  
 of Cuttings in the Flesh 770<sup>a</sup> (Eager)  
 of Print . . . . . 2455<sup>a</sup> (Richardson)
- Mark (verb) . . . . . 1985<sup>b</sup> (Pratt)

- Mark, The Gospel according to . . . . . 1987<sup>b</sup> (Farmer)
- Authorship . . . . . 1989<sup>b</sup>
- Eusebius . . . . . 1990<sup>a</sup>
- External evidence . . . . . 1989<sup>b</sup>
- Internal evidence . . . . . 1990<sup>b</sup>
- Irenaeus . . . . . 1990<sup>a</sup>
- Papias . . . . . 1989<sup>b</sup>
- Peter's relation to . . . . . 1989<sup>b</sup>
- of Catechist . . . . . 582<sup>b</sup> (Gerberding)
- Contents and characteristics . . . . . 1987<sup>b</sup>
- Graphic details . . . . . 1988<sup>b</sup>
- Jesus as teacher . . . . . 1988<sup>a</sup>
- Mighty works of Jesus . . . . . 1988<sup>a</sup>
- OT quotations . . . . . 1988<sup>a</sup>
- Peculiarities . . . . . 1987<sup>b</sup>
- Scope . . . . . 1987<sup>b</sup>
- Date and place of composition . . . . . 1992<sup>b</sup>
- Caesarea or Antioch . . . . . 1993<sup>b</sup>
- Varying data . . . . . 1992<sup>b</sup>
- Historicity . . . . . 1993<sup>a</sup>
- Language . . . . . 1989<sup>a</sup>
- Original language . . . . . 1989<sup>b</sup>
- Vocabulary . . . . . 1989<sup>a</sup>
- Leading doctrines . . . . . 1994<sup>b</sup>
- Eschatology . . . . . 1994<sup>b</sup>
- Person of Christ . . . . . 1994<sup>b</sup>
- Salvation . . . . . 1994<sup>b</sup>
- Literature on . . . . . 1995<sup>a</sup>
- of Literature, Subapoc. . . . . 1901<sup>a</sup> (Cowan)
- of Luke, The Gospel of . . . . . 1939<sup>a</sup> (A. T. Robertson)
- Style . . . . . 1989<sup>b</sup>
- of Mark, John . . . . . 1986<sup>b</sup> (Farmer)
- of Matthew, Gospel of . . . . . 2012<sup>a</sup> (Schodde)
- Purpose and plan . . . . . 1993<sup>b</sup>
- Gospel for Romans . . . . . 1993<sup>b</sup>
- Plan of Mark . . . . . 1994<sup>a</sup>
- Second Gospel, our . . . . . 1987<sup>b</sup>
- Sources and integrity . . . . . 1991<sup>a</sup>
- Apostolic traditions . . . . . 1992<sup>a</sup>
- Early writings . . . . . 1991<sup>b</sup>
- Oral instruction . . . . . 1991<sup>a</sup>
- Peter's leadership . . . . . 1992<sup>a</sup>
- Text . . . . . 1988<sup>b</sup>
- Problem of 16 9-20 . . . . . 1989<sup>a</sup>
- Mark, John . . . . . 1986<sup>b</sup> (Farmer)
- Abandonment of Paul . . . . . 1987<sup>a</sup>
- Extra-Biblical traditions . . . . . 1987<sup>a</sup>
- History . . . . . 1986<sup>b</sup>
- of Mark, The Gospel according to . . . . . 1987<sup>b</sup> (Farmer)
- Name and family . . . . . 1986<sup>b</sup>
- Reunion with Paul . . . . . 1987<sup>a</sup>
- Market, Marketplace . . . . . 1995<sup>b</sup> (Raffety)
- of Appii Forum . . . . . 209<sup>a</sup> (Allen)
- of Traffic . . . . . 3004<sup>b</sup> (Raffety)
- Market, Sheep . . . . . 2758<sup>a</sup>
- Marmoth (Meremoth) . . . . . 1996<sup>a</sup>
- Maroth . . . . . 1996<sup>a</sup>
- Marriage . . . . . 1996<sup>b</sup> (Eager)
- of Affinity . . . . . 66<sup>a</sup> (W. W. Davies)
- Betrothal . . . . . 1997<sup>b</sup>
- Ceremonies . . . . . 1998<sup>a</sup>
- Divorce . . . . . 1999<sup>a</sup>
- of Divorce . . . . . 863<sup>b</sup> (W. W. Davies); 865<sup>a</sup> (Caverno)
- Hebrew customs . . . . . 1996<sup>b</sup>
- of Heir . . . . . 1369<sup>a</sup> (Easton)
- Importance of . . . . . 1997<sup>a</sup>
- of Of Isaac . . . . . 1494<sup>a</sup> (Boyd)
- Jesus' use of . . . . . 1999<sup>a</sup>
- of Levirate Marriage . . . . . 526<sup>a</sup> (Hirsch)
- Matriarchal ideas . . . . . 1997<sup>b</sup>
- Origins of . . . . . 1996<sup>b</sup>
- Polygamy . . . . . 1998<sup>a</sup>; 2416<sup>a</sup> (Caverno)
- Purchase of wife . . . . . 1997<sup>a</sup>
- of Spouse . . . . . 2846<sup>b</sup>
- of Stranger and Sojourner (in OT) . . . . . 2865<sup>a</sup> (Wiener)
- Supper . . . . . 1998<sup>a</sup>
- of Veil . . . . . 3047<sup>a</sup> (Easton)
- of Woman . . . . . 3101<sup>a</sup> (Pratt)
- Marrow . . . . . 1999<sup>b</sup> (Luerig)
- Marsena . . . . . 1999<sup>b</sup>
- Marsh . . . . . 2000<sup>a</sup> (Eager)
- Mars' Hill
- of Areopagus . . . . . 238<sup>b</sup> (Harry)
- Marshal . . . . . 2000<sup>a</sup> (Eager)
- Mart
- of Market, Marketplace . . . . . 1995<sup>b</sup> (Raffety)
- Martha . . . . . 2000<sup>a</sup> (Kerr)
- of Mary . . . . . 2005<sup>b</sup> (Sweet)
- Martyr . . . . . 2000<sup>b</sup>
- Marvel, Marvelous . . . . . 2001<sup>a</sup> (W. L. Walker)
- Mary (name) . . . . . 2001<sup>a</sup> (Sweet)
- of Miriam . . . . . 2066<sup>a</sup> (Lees)
- Name and identification . . . . . 2001<sup>a</sup>
- The Maries of the NT . . . . . 2001<sup>a</sup>
- Problems . . . . . 2001<sup>b</sup>
- of Simon . . . . . 2795<sup>a</sup> (S. F. Hunter)
- Mary (of Bethany) . . . . . 2004<sup>b</sup> (Sweet)
- Anointing of Jesus . . . . . 2004<sup>b</sup>
- Attack on Luke's narrative . . . . . 2004<sup>b</sup>
- Character . . . . . 2005<sup>b</sup>
- Evidence compared . . . . . 2005<sup>a</sup>
- Mary and Martha . . . . . 2005<sup>b</sup>
- Mary (wife of Clopas) . . . . . 2001<sup>b</sup>
- of Alphaeus . . . . . 106<sup>a</sup> (Fortune)
- Mother of James and Joseph . . . . . 2006<sup>a</sup>
- Mother of John Mark . . . . . 2006<sup>b</sup>
- of Mark, John . . . . . 1986<sup>b</sup> (Farmer)
- Mary (Magdalene) . . . . . 2003<sup>b</sup> (Sweet)
- of Demon, Demoniac . . . . . 827<sup>b</sup> (Sweet)

- Mary (Magdalene)—*continued*  
 Her malady . . . . . 2004<sup>a</sup>  
 Not the sinful woman . 2003<sup>b</sup>
- Mary (the other) . . . . . 2001<sup>a</sup> (Sweet)
- Mary (of Rome) . . . . . 2001<sup>b</sup>
- Mary (Virgin) . . . . . 2001<sup>b</sup> (Sweet)  
 Cana narrative . . . . . 2002<sup>a</sup>  
 In doctrine and tradi-  
 tion . . . . . 2003<sup>a</sup>  
 of Immaculate Con-  
 ception . . . . . 1456<sup>b</sup> (Sweet)  
 Infancy narratives . . . 2001<sup>b</sup>  
 Jesus and . . . . . 2002<sup>b</sup>  
 of Jesus Christ . . . . . 1633<sup>b</sup> (Orr)  
 Mary's children . . . . . 2003<sup>a</sup>  
 Mary in the Christian  
 community . . . . . 2002<sup>b</sup>  
 Mary at the cross . . . . 2002<sup>b</sup>  
 of Perpetual Virginity . 519<sup>b</sup> (Jacobs)  
 Roman Catholic views . 2003<sup>a</sup>  
 of Virgin-birth of Jesus  
 Christ . . . . . 3054<sup>b</sup> (Sweet)
- Mary, The Passing of  
 of Apocryphal Gospels . 195<sup>a</sup> (Hutchison)
- Masaloth  
 of Mesaloth . . . . . 2037<sup>b</sup>
- Maschil  
 of Psalms, Book of . . . 2487<sup>a</sup> (Sampey)
- Mash (Meshech) . . . . . 2006<sup>b</sup> (Orr)
- Mashal . . . . . 2006<sup>b</sup>  
 of Mishal . . . . . 2066<sup>b</sup>
- Masias . . . . . 2006<sup>b</sup>
- Masman (Maasmas) . . . . 1946<sup>a</sup>
- Mason . . . . . 2007<sup>a</sup>  
 of Architecture . . . . . 234<sup>a</sup> (A. C. Dickie)  
 of Building . . . . . 527<sup>a</sup> (A. C. Dickie)  
 of Crafts . . . . . 734<sup>a</sup> (Patch)  
 of Fortification . . . . . 1138<sup>a</sup> (Nicol)  
 of Gebal . . . . . 1180<sup>a</sup> (Porter)  
 of House . . . . . 1434<sup>b</sup> (A. C. Dickie)
- Masorah  
 of Text of the OT . . . . 2963<sup>a</sup> (Weir)
- Maspha . . . . . 2007<sup>a</sup>  
 of Mizpah, Mizpeh . . . 2068<sup>a</sup> (Ewing)
- Masrekah . . . . . 2007<sup>a</sup>
- Massa . . . . . 2007<sup>a</sup>
- Massacre of the Inno-  
 cents . . . . . 1471<sup>a</sup> (Sweet)
- Massah and Meribah . . . . 2007<sup>a</sup> (Ewing)  
 of Rephidim . . . . . 2560<sup>a</sup> (Ewing)  
 of Sinai (Horeb) . . . . 2802<sup>b</sup> (Conder)
- Massias (Maaseiah) . . . . 2007<sup>b</sup>
- Mast  
 of Ships and Boats . . . . 2775<sup>b</sup> (Nicol)
- Master . . . . . 2007<sup>b</sup> (W. L. Walker)  
 of Assemblies, Masters  
 of . . . . . 288<sup>b</sup> (S. F. Hunter)  
 of Rabboni . . . . . 2522<sup>a</sup>
- Mastery . . . . . 2008<sup>a</sup> (W. L. Walker)
- Mastic, Mastick . . . . . 2008<sup>a</sup> (Ewing)
- Mathanias (Apoc)  
 of Matthanias . . . . . 2009<sup>a</sup>
- Mathelas (Maaseiah) . . . 2008<sup>a</sup>
- Mathusala . . . . . 2008<sup>a</sup>  
 of Methuselah . . . . . 2045<sup>a</sup>
- Matred . . . . . 2008<sup>a</sup>
- Matri . . . . . 2008<sup>a</sup>
- Matriarchal Customs  
 of Marriage . . . . . 1997<sup>b</sup> (Eager)
- Matrites . . . . . 2008<sup>a</sup>
- Mattan . . . . . 2008<sup>a</sup>
- Mattanah . . . . . 2008<sup>a</sup> (Ewing)
- Mattaniah . . . . . 2008<sup>b</sup> (Wallace)  
 of Mamnitaneus . . . . . 1973<sup>a</sup>  
 of Matthanias . . . . . 2009<sup>a</sup>
- Mattaniah (Othonias) . . . 2008<sup>b</sup>
- Mattatha . . . . . 2008<sup>b</sup>
- Mattathah  
 of Mattattah . . . . . 2009<sup>a</sup>
- Mattathias . . . . . 2008<sup>b</sup> (Angus); 158<sup>a</sup>  
 (Pratt)  
 of Asmoneans . . . . . 283<sup>a</sup> (Dosker)  
 of Maccabaeus . . . . . 1946<sup>b</sup> (Hutchison)
- Mattathias (Mattattah) . 2009<sup>a</sup>
- Mattathias the Macca-  
 bee . . . . . 283<sup>b</sup> (Dosker)
- Mattattah (Mattathias) . 2009<sup>a</sup>  
 of Matthias . . . . . 2012<sup>a</sup> (Kerr)
- Mattenai . . . . . 2009<sup>a</sup>  
 of Mamnitaneus . . . . . 1973<sup>a</sup>
- Matter . . . . . 2009<sup>a</sup> (Breslich)
- Matthan . . . . . 2009<sup>a</sup>  
 of Matthat . . . . . 2009<sup>a</sup>
- Matthanias . . . . . 2009<sup>a</sup>  
 of Mattaniah . . . . . 2008<sup>b</sup> (Wallace)
- Matthat . . . . . 2009<sup>a</sup>  
 of Matthan . . . . . 2009<sup>a</sup>
- Matthew, the Apostle . . . 2009<sup>a</sup> (Schodde)
- Matthew's Bible . . . . . 948<sup>b</sup> (Hutchison)
- Matthew, The Gospel of . 2009<sup>b</sup> (Schodde)  
 Authorship . . . . . 2010<sup>a</sup>  
 of Canon of NT . . . . . 563<sup>a</sup> (Riggs)  
 Canonicity . . . . . 2010<sup>a</sup>  
 Contents and char-  
 acter . . . . . 2010<sup>b</sup>  
 Date . . . . . 2012<sup>a</sup>  
 of Gospel according to  
 the Hebrews . . . . . 196<sup>b</sup> (Hutchison)  
 of Gospels, The Synop-  
 tic . . . . . 1281<sup>a</sup> (Iverach)
- Integrity and unity . . . . 2009<sup>b</sup>
- Jews, written for . . . . . 2011<sup>a</sup>
- of Levi (general) . . . . . 1868<sup>b</sup>
- Literary problems of . . . 2011<sup>b</sup>  
 of Literature, Sub-  
 apos . . . . . 1901<sup>a</sup> (Cowan)
- of Mark, Gospel of . . . . 1987<sup>b</sup> (Farmer)
- Purpose . . . . . 2011<sup>a</sup>
- of Quotations from the  
 OT . . . . . 2515<sup>b</sup> (Sweet)
- Relation to Greek and  
 Aramaic Gospels . . . . . 2010<sup>a</sup>
- Relation to Mark and  
 Luke . . . . . 2011<sup>b</sup>

- Matthias . . . . . 2012<sup>a</sup> (Kerr)  
   cf Andrew . . . . . 131<sup>a</sup> (Kerr)  
   cf Nathanael . . . . . 2121<sup>a</sup> (Kerr)  
 Mattithiah . . . . . 2012<sup>b</sup> (Wallace)  
   of Mazitias . . . . . 2013<sup>a</sup>  
 Mattock . . . . . 2012<sup>b</sup>  
   of Tools . . . . . 2998<sup>b</sup> (Easton)  
 Maul . . . . . 2012<sup>b</sup>  
 Mauzzim . . . . . 2012<sup>b</sup> (Wallace)  
 Maw . . . . . 2013<sup>a</sup> (Luering)  
 Mazitias . . . . . 2013<sup>a</sup>  
   of Mattithiah . . . . . 2012<sup>b</sup> (Wallace)  
 Mazzaloth  
   of Astrology . . . . . 298<sup>b</sup> (Maunder)  
 Mazzaroth . . . . . 2013<sup>a</sup>  
   of Astronomy . . . . . 300<sup>b</sup> (Maunder)  
 Mazzebah  
   of Pillar . . . . . 2398<sup>b</sup> (Orr)  
 Meadow . . . . . 2013<sup>a</sup> (Day)  
   of Plain . . . . . 2406<sup>b</sup> (Day)  
   of Reed . . . . . 2544<sup>a</sup> (Masterman)  
 Meah  
   of Hammeah . . . . . 1325<sup>b</sup> (Masterman)  
 Meal . . . . . 2013<sup>b</sup>  
   of Food . . . . . 1122<sup>a</sup> (Eager)  
 Meal Offering  
   of Sacrifice, OT . . . . . 2643<sup>b</sup> (Reeve)  
 Meals, Meal-time . . . . . 2013<sup>b</sup> (Eager)  
   of Banquet . . . . . 384<sup>b</sup> (Eager)  
   of Bread . . . . . 514<sup>b</sup> (Eager)  
   Cereals . . . . . 2013<sup>b</sup>  
   Customs at . . . . . 2015<sup>a</sup>  
   of Dress . . . . . 875<sup>b</sup> (Eager)  
   of Food . . . . . 1121<sup>b</sup> (Eager)  
   Frequency . . . . . 2014<sup>b</sup>  
   of Leaven . . . . . 1862<sup>a</sup> (Eager)  
   of Lord's Supper . . . . . 1921<sup>b</sup> (Gummev)  
   Meat . . . . . 2014<sup>a</sup>  
   of Oil . . . . . 2182<sup>b</sup> (Patch)  
   Posture at . . . . . 2015<sup>a</sup>  
   Preparation of food . . . . . 2013<sup>b</sup>  
   Primitive customs . . . . . 2013<sup>b</sup>  
   Sabbath eating . . . . . 2015<sup>a</sup>  
   Time of eating . . . . . 2014<sup>b</sup>  
   Vegetables . . . . . 2014<sup>a</sup>  
 Mean . . . . . 2015<sup>b</sup> (Breslich)  
 Meani (Maani) . . . . . 1945<sup>b</sup>; 2016<sup>a</sup>  
 Mearah . . . . . 2016<sup>a</sup>  
 Measure, Measures . . . . . 2016<sup>a</sup> (Porter)  
   of Mete . . . . . 2044<sup>b</sup> (Porter)  
 Measuring Line . . . . . 2016<sup>a</sup> (Porter)  
   of Line . . . . . 1894<sup>a</sup> (Orr)  
   of Weights and Measures . . . . . 3079<sup>a</sup> (Porter)  
 Measuring Reed . . . . . 2016<sup>b</sup>  
   of Cubit . . . . . 765<sup>a</sup> (Porter)  
 Meat . . . . . 2016<sup>b</sup>  
   of Meals . . . . . 2014<sup>a</sup> (Eager)  
 Meat Offering  
   of Sacrifice, OT . . . . . 2643<sup>b</sup> (Reeve)  
 Mebunnai . . . . . 2016<sup>b</sup> (Wallace)  
 Mecca . . . . . 218<sup>b</sup> (Weir)  
 Mecca Balsam . . . . . 381<sup>a</sup> (Macalister)  
 Mecherathite . . . . . 2016<sup>b</sup>  
 Meconah . . . . . 2016<sup>b</sup>  
 Medaba (Medeba) . . . . . 2016<sup>b</sup>  
 Medad . . . . . 2016<sup>b</sup> (E. D. Isaacs)  
 Medan . . . . . 2016<sup>b</sup>  
 Medeba (Medaba) . . . . . 2016<sup>b</sup>; 2017<sup>a</sup> (Ewing)  
 Medes . . . . . 2017<sup>a</sup> (Tisdall)  
   Biblical references to . . . . . 2017<sup>a</sup>  
   Conclusion . . . . . 2025<sup>b</sup>  
   History . . . . . 2017<sup>a</sup>  
   Racial connections . . . . . 2017<sup>a</sup>  
 Media . . . . . 2018<sup>a</sup> (Tisdall)  
 Median  
   of Darius . . . . . 788<sup>a</sup> (R. D. Wilson)  
   of Media . . . . . 2018<sup>a</sup> (Tisdall)  
 Mediation, Mediator . . . . . 2018<sup>a</sup> (Edwards)  
   of Atonement . . . . . 321<sup>a</sup> (Carver)  
   Introductory . . . . . 2018<sup>b</sup>  
   Principle of mediation . . . . . 2018<sup>b</sup>  
   Terms used . . . . . 2018<sup>b</sup>  
   of Messiah . . . . . 2039<sup>a</sup> (Crichton)  
 In NT . . . . . 2021<sup>b</sup>  
   Christ as King . . . . . 2021<sup>b</sup>  
   Christ as Priest . . . . . 2021<sup>b</sup>  
   Christ as Prophet . . . . . 2021<sup>b</sup>  
   Christ as Redeemer . . . . . 2021<sup>b</sup>  
   Fourth Gospel . . . . . 2025<sup>a</sup>  
   Hebrews, Epistle to . . . . . 2024<sup>b</sup>  
   Johannine Epistles . . . . . 2025<sup>b</sup>  
   Lord's Supper . . . . . 2022<sup>a</sup>  
   Paul's teachings . . . . . 2023<sup>a</sup>  
   Primitive apostolic teaching . . . . . 2022<sup>b</sup>  
   Speeches and letters . . . . . 2022<sup>b</sup>  
   Synoptic Gospels . . . . . 2021<sup>b</sup>  
 In OT . . . . . 2019<sup>a</sup>  
   Agents, angels . . . . . 2020<sup>b</sup>  
   Agents, Wisdom . . . . . 2021<sup>a</sup>  
   King, the . . . . . 2020<sup>b</sup>  
   Messiah, the . . . . . 2020<sup>b</sup>  
   Negative teaching . . . . . 2019<sup>a</sup>  
   Positive teaching . . . . . 2019<sup>a</sup>  
   Priestly mediation . . . . . 2019<sup>b</sup>  
   Prophetic period . . . . . 2019<sup>b</sup>  
   Sacrificial system . . . . . 2020<sup>a</sup>  
   Suffering Servant . . . . . 2020<sup>b</sup>  
   of Philo Judaeus . . . . . 2380<sup>a</sup> (Wenley)  
   of Priests and Levites . . . . . 2446<sup>b</sup> (Wiener)  
   of Prophets . . . . . 2459<sup>b</sup> (Orelli)  
   of Propitiation . . . . . 2467<sup>a</sup> (Carver)  
   of Ransom . . . . . 2530<sup>a</sup> (M'Caig)  
   of Reconciliation . . . . . 2536<sup>a</sup> (M'Caig)  
   of Sacrifice, NT . . . . . 2651<sup>a</sup> (Williams)  
   of Salvation . . . . . 2665<sup>a</sup> (Easton)  
   Semi and non-canonical literature . . . . . 2021<sup>a</sup>  
   Logos idea . . . . . 2021<sup>a</sup>  
   of Servant of Jehovah . . . . . 2739<sup>a</sup> (Hough)  
   of Wisdom . . . . . 3089<sup>a</sup> (Easton)  
 Medicine . . . . . 2026<sup>a</sup> (Macalister)

- Meditation . . . . . 2026<sup>a</sup> (W. L. Walker)  
 Mediterranean Sea . . . . . 2028<sup>b</sup> (Heidel)  
   of Sea, The Great . . . . . 2707<sup>b</sup> (Ewing)  
 Meedda (Meeda) . . . . . 2027<sup>a</sup>  
   of Mehida . . . . . 2028<sup>a</sup>  
 Meek  
   of Quiet . . . . . 2515<sup>b</sup> (M. O. Evans)  
 Meekness . . . . . 2027<sup>a</sup> (W. L. Walker)  
 Meet . . . . . 2027<sup>b</sup> (W. L. Walker)  
 Megiddo . . . . . 2027<sup>b</sup> (Ewing)  
   of Armageddon (Har-  
   magedon) . . . . . 1340<sup>a</sup> (Ewing)  
   of Palestine, Recent  
   Exploration . . . . . 2229<sup>a</sup> (Cobern)  
   of Pharaoh-necoh . . . . . 2360<sup>a</sup> (Nicol)  
 Mehetabel, Mehetabeel . . . . . 2028<sup>a</sup>  
 Mehida (Meedda) . . . . . 2028<sup>a</sup>  
 Mehir . . . . . 2028<sup>a</sup>  
 Meholathite . . . . . 2028<sup>a</sup>  
   of Abel-meholah . . . . . 6<sup>a</sup> (Beecher)  
 Mehujael . . . . . 2028<sup>a</sup>  
 Mehuman . . . . . 2028<sup>a</sup>  
 Mehunim (Meunim)  
   of Maon . . . . . 1984<sup>a</sup> (Ewing)  
 Mejargon  
   of Makaz . . . . . 1968<sup>a</sup>  
 Me-jarkon . . . . . 2028<sup>a</sup>  
 Mekonah  
   of Meconah . . . . . 2016<sup>b</sup>  
 Melatiah . . . . . 2028<sup>b</sup>  
 Melchi . . . . . 2028<sup>b</sup>  
 Melchiah (Malchiah) . . . . . 2028<sup>b</sup>  
   of Malchijah . . . . . 1971<sup>a</sup> (Wallace)  
 Melchias . . . . . 2028<sup>b</sup>  
   of Malchijah . . . . . 1971<sup>a</sup> (Wallace)  
 Melchiel . . . . . 2028<sup>b</sup>  
 Melchishua  
   of Malchishua . . . . . 1971<sup>a</sup>  
 Melchizedek, Melchise-  
 dec . . . . . 2028<sup>b</sup> (Roberts)  
   of Archaeological The-  
   ory of . . . . . 230<sup>a</sup> (Kyle)  
   of Jerusalem . . . . . 1613<sup>b</sup> (Masterman)  
   Name and references . . . . . 2028<sup>b</sup>  
   Reference to, in He-  
   brews . . . . . 2028<sup>b</sup>  
   Reference to, in Psalm  
   110 4 . . . . . 2028<sup>b</sup>  
 Tell el-Amarna testi-  
 mony . . . . . 2029<sup>a</sup>  
   of Tell el-Amarna  
   Tablets . . . . . 2928<sup>b</sup> (Kyle)  
 Melea . . . . . 2029<sup>b</sup>  
 Melech . . . . . 2029<sup>b</sup>  
 Melicu (Malluchi) . . . . . 2029<sup>b</sup>  
 Melita . . . . . 2029<sup>b</sup> (Allen)  
   of Publius . . . . . 2501<sup>a</sup> (Kerr)  
 Melody . . . . . 2029<sup>b</sup>  
   of Music . . . . . 2097<sup>a</sup> (Millar)  
 Melons . . . . . 2030<sup>a</sup>  
 Melzar . . . . . 2030<sup>a</sup> (R. D. Wilson)  
   of Steward . . . . . 2853<sup>b</sup> (Reeve)  
 Mem . . . . . 2030<sup>a</sup>  
   of Alphabet . . . . . 103<sup>b</sup> (Richardson)  
 Member . . . . . 2030<sup>a</sup> (Luering)  
   of Body . . . . . 491<sup>b</sup> (Hirsch; Marais;  
   Pratt)  
   of Concision . . . . . 696<sup>b</sup>  
   of Eunuch . . . . . 1037<sup>a</sup> (Eager)  
 Memeroth (Meraioth) . . . . . 2030<sup>b</sup>  
 Memmius, Quintus . . . . . 2030<sup>b</sup> (Angus)  
   of Manius . . . . . 1982<sup>a</sup> (Angus)  
 Memorial, Memory . . . . . 2030<sup>b</sup> (W. L. Walker)  
   of Name . . . . . 2112<sup>a</sup> (W. L. Walker)  
 Memphis . . . . . 2030<sup>b</sup> (Petrie)  
   Excavations . . . . . 2031<sup>a</sup>  
   Founders . . . . . 2031<sup>a</sup>  
   Name . . . . . 2030<sup>b</sup>  
   of Noph . . . . . 2155<sup>a</sup>  
   Political position . . . . . 2031<sup>a</sup>  
 Memucan . . . . . 2031<sup>b</sup>  
 Menaen  
   of Herod (Antipas) . . . . . 1381<sup>b</sup> (Dosker)  
 Menahem . . . . . 2031<sup>b</sup> (Caldecott)  
   Accession and reign . . . . . 2031<sup>b</sup>  
   Chronological prob-  
   lems . . . . . 2032<sup>a</sup>  
   of Chronology of OT . . . . . 635<sup>a</sup> (Mack)  
   Early acts . . . . . 2031<sup>b</sup>  
   of Jehu . . . . . 1586<sup>a</sup> (Caldecott)  
   of Pekahiah . . . . . 2296<sup>a</sup> (Caldecott)  
   Relations with Assyria . . . . . 2031<sup>b</sup>  
 Menahem (Manaen) . . . . . 1976<sup>b</sup> (Orr)  
 Menan (Menna) . . . . . 2033<sup>a</sup>  
 Mene, Mene, Tekel,  
   Upharsin . . . . . 2032<sup>a</sup> (R. D. Wilson)  
 Menelaus . . . . . 2032<sup>b</sup> (Angus)  
 Menestheus . . . . . 2033<sup>a</sup>  
   of Apollonius . . . . . 200<sup>b</sup> (Hutchison)  
 Meni . . . . . 2033<sup>a</sup>  
   of Divination . . . . . 860<sup>a</sup> (T. W. Davies)  
   of Gad, God of Good  
   Luck . . . . . 1152<sup>a</sup> (Stearns)  
 Menna (Menan) . . . . . 2033<sup>a</sup>  
 Menuhah . . . . . 2033<sup>a</sup>  
   of Manahath . . . . . 1976<sup>b</sup> (Ewing)  
 Menuhoth . . . . . 2033<sup>a</sup> (Wallace)  
   of Hatsi-hammenu-  
   choth . . . . . 1343<sup>b</sup>  
   of Manahath . . . . . 1976<sup>b</sup> (Ewing)  
 Meonenim, Oak of . . . . . 2033<sup>b</sup>  
   of Augurs' Oak . . . . . 331<sup>a</sup> (T. W. Davies)  
   of Moreh, Hill of . . . . . 2082<sup>a</sup> (Ewing)  
   of Plain of the Pillar . . . . . 2407<sup>b</sup> (Ewing)  
 Meonothai . . . . . 2033<sup>b</sup>  
 Mephaath . . . . . 2033<sup>b</sup>  
 Mephibosheth . . . . . 2033<sup>b</sup> (Wallace)  
   of Armoni . . . . . 251<sup>a</sup>  
   of Ish-bosheth . . . . . 1508<sup>b</sup> (Breslich)  
   of Merib-baal . . . . . 2036<sup>b</sup> (Wallace)  
   of Rizpah . . . . . 2595<sup>a</sup> (Wallace)  
 Merab . . . . . 2034<sup>a</sup> (Wallace)  
   of Rizpah . . . . . 2595<sup>a</sup> (Wallace)  
 Meraiah . . . . . 2034<sup>b</sup>



- Meraioth (Memeroth)... 2030<sup>b</sup>  
 Meran  
   cf Merran . . . . . 2037<sup>b</sup> (Ewing)  
 Merari . . . . . 2034<sup>b</sup> (Wallace)  
   cf Merarites . . . . . 2035<sup>a</sup>  
 Merarites . . . . . 2035<sup>a</sup>  
   cf Merari . . . . . 2034<sup>b</sup> (Wallace)  
 Merathaim . . . . . 2035<sup>a</sup>  
 Merchandise . . . . . 2035<sup>a</sup> (Raffety)  
   cf Traffic . . . . . 3004<sup>b</sup> (Raffety)  
   cf Wares . . . . . 3072<sup>a</sup> (Raffety)  
 Merchant, Merchantman  
   cf Commerce . . . . . 687<sup>b</sup> (Pollard)  
   cf Merchandise . . . . . 2035<sup>a</sup> (Raffety)  
   cf Trade . . . . . 3002<sup>a</sup> (Easton)  
 Mercury, Mercurius . . . . . 2035<sup>a</sup> (M. O. Evans)  
   cf Greece, Religion in. 1297<sup>a</sup> (Fairbanks)  
   cf Hermes . . . . . 1377<sup>b</sup>  
   cf Jupiter . . . . . 1781<sup>a</sup> (Easton)  
 Mercy, Merciful . . . . . 2035<sup>a</sup> (W. L. Walker)  
   cf Kindness . . . . . 1799<sup>a</sup> (W. L. Walker)  
   cf Lovingkindness . . . . . 1934<sup>a</sup> (W. L. Walker)  
   cf Pity . . . . . 2402<sup>b</sup> (W. L. Walker)  
 Mercy-seat, The . . . . . 2038<sup>a</sup> (Caldecott)  
   cf Altar . . . . . 106<sup>b</sup> (Wiener)  
   cf Ark of Covenant . . . . . 242<sup>b</sup> (Lotz)  
   cf Atonement, Day of. 324<sup>b</sup> (Möller)  
   cf Christianity . . . . . 627<sup>b</sup> (Orr)  
   cf Holy of Holies . . . . . 1405<sup>a</sup> (Caldecott)  
   cf Propitiation . . . . . 2467<sup>a</sup> (Carver)  
   cf Tabernacle . . . . . 2890<sup>b</sup> (Caldecott; Orr)  
 Mered . . . . . 2036<sup>a</sup> (Wallace)  
   cf Bithiah . . . . . 483<sup>a</sup> (Hirsch)  
 Meremoth, Meraioth,  
   Memeroth . . . . . 2036<sup>a</sup> (Wallace)  
   cf Marmoth . . . . . 1996<sup>a</sup>  
   cf Uriah, Urijah . . . . . 3040<sup>a</sup> (Easton)  
 Meribah  
   cf Massah and Meri-  
     bah . . . . . 2007<sup>a</sup> (Ewing)  
   cf Rephidim . . . . . 2560<sup>a</sup> (Ewing)  
   cf Sinai (Horeb) . . . . . 2802<sup>b</sup> (Conder)  
 Meribath-kadesh, Meri-  
   both-kadesh . . . . . 2036<sup>b</sup>  
   cf Massah and Meribah 2007<sup>a</sup> (Ewing)  
 Merib-baal . . . . . 2036<sup>b</sup> (Wallace)  
   cf Mephibosheth . . . . . 2033<sup>b</sup> (Wallace)  
 Merodach . . . . . 2036<sup>b</sup>  
 Merodach-baladan . . . . . 2036<sup>b</sup> (R. D. Wilson)  
   cf Astronomy . . . . . 300<sup>b</sup> (Maunder)  
   cf Babylonia and As-  
     syria, Religion of. . . . . 368<sup>b</sup> (Rogers)  
   cf Baladan . . . . . 379<sup>b</sup> (R. D. Wilson)  
   cf Nimrod . . . . . 2147<sup>b</sup> (Mack)  
 Merom, Waters of . . . . . 2037<sup>a</sup> (Wright)  
   cf Hazor . . . . . 1347<sup>b</sup> (Ewing)  
   cf Jordan Valley . . . . . 1735<sup>b</sup> (Wright)  
 Meronothite . . . . . 2037<sup>a</sup>  
 Meroz . . . . . 2037<sup>b</sup> (Ewing)  
 Merran . . . . . 2037<sup>b</sup> (Ewing)  
 Meruth  
   cf Emmeruth . . . . . 941<sup>a</sup>
- Mesaloth . . . . . 2037<sup>b</sup>  
 Mesech  
   cf Meshech . . . . . 2038<sup>a</sup> (Wallace)  
 Mesha . . . . . 2037<sup>b</sup> (Ewing)  
   cf Jehoram . . . . . 1580<sup>b</sup> (Mosiman)  
   cf Moab . . . . . 2071<sup>a</sup> (Porter)  
   cf Moabite Stone . . . . . 2071<sup>b</sup> (Sayce)  
 Meshach . . . . . 2038<sup>a</sup> (R. D. Wilson)  
   cf Mishael . . . . . 2066<sup>b</sup>  
   cf Shadrach . . . . . 2746<sup>a</sup> (R. D. Wilson)  
 Meshech (Mash) . . . . . 2006<sup>b</sup> (Orr); 2038<sup>a</sup> (Wal-  
   lace)  
 Meshelemiah . . . . . 2038<sup>b</sup>  
   cf Shallum . . . . . 2747<sup>a</sup> (Umbach)  
   cf Shelemiah . . . . . 2758<sup>b</sup> (Wolf)  
 Meshezabel . . . . . 2038<sup>b</sup>  
 Meshillemith . . . . . 2038<sup>b</sup>  
 Meshillemoth . . . . . 2038<sup>b</sup>  
 Meshobab . . . . . 2038<sup>b</sup>  
 Meshullam . . . . . 2038<sup>b</sup> (Lees)  
   cf Mosollamus . . . . . 2091<sup>b</sup>  
   cf Olamus . . . . . 2183<sup>b</sup>  
   cf Shallum . . . . . 2747<sup>a</sup> (Umbach)  
 Meshullemeth . . . . . 2039<sup>a</sup>  
   cf Meshullam . . . . . 2038<sup>b</sup> (Lees)  
 Mesobaite  
   cf Mezobaite . . . . . 2045<sup>a</sup>  
 Mesopotamia  
   cf Aram . . . . . 222<sup>a</sup>  
   cf Laban . . . . . 1819<sup>a</sup> (Boyd)  
 Mess . . . . . 2039<sup>a</sup>  
 Messenger . . . . . 2039<sup>a</sup> (Breslich)  
   cf Malachi . . . . . 1969<sup>b</sup> (Robinson)  
 Messiah . . . . . 2039<sup>a</sup> (Crichton)  
   cf Apocalyptic Litera-  
     ture (Jewish) . . . . . 161<sup>b</sup> (J. E. H. Thomson)  
   cf Doctrine of, in Fourth  
     Gospel . . . . . 1726<sup>b</sup> (Iverach)  
   cf Eschatology of the  
     OT . . . . . 972<sup>a</sup> (Orr)  
   cf Hope . . . . . 1419<sup>b</sup> (Easton)  
   cf Idea of, in Synoptic  
     Gospels . . . . . 1284<sup>b</sup> (Iverach)  
   cf Immanuel . . . . . 1457<sup>b</sup> (A. W. Evans)  
   cf Jesus Christ . . . . . 1629<sup>b</sup> (Orr)  
 Meaning and use of  
   term . . . . . 2039<sup>b</sup>  
   cf Mediation, Media-  
     tor . . . . . 2018<sup>a</sup> (Edwards)  
 Messianic hope . . . . . 2039<sup>b</sup>  
 New Testament . . . . . 2042<sup>b</sup>  
   Christian elements . . . . . 2043<sup>b</sup>  
   Christian transfor-  
     mation . . . . . 2043<sup>a</sup>  
   Fulfilment in Jesus . . . . . 2043<sup>b</sup>  
   Jesus' attitude to-  
     ward Messiahship . . . . . 2043<sup>a</sup>  
   Jewish conception . . . . . 2042<sup>b</sup>  
   Son of Man . . . . . 2043<sup>a</sup>  
 Old Testament  
   In Isaiah . . . . . 2040<sup>a</sup>

- Messiah—*continued*  
 Old Testament—*continued*  
 In Jeremiah and Ezekiel . . . . . 2040<sup>b</sup>  
 Messianic King . . . . . 2040<sup>a</sup>  
 Prophetic and priestly relations . . . . . 2040<sup>b</sup>  
 Rise of apocalyptic idea . . . . . 2041<sup>b</sup>  
 Servant of Jehovah. 2041<sup>a</sup>  
 of Pauline Theology. . . . . 2289<sup>a</sup> (Easton)  
 Pre-Christian age . . . . . 2041<sup>b</sup>  
 Apocalyptic literature . . . . . 2042<sup>a</sup>  
 Maccabean times . . . . . 2041<sup>b</sup>  
 Post-prophetic age. 2041<sup>b</sup>  
 of Prophecy . . . . . 2464<sup>b</sup> (Orelli); 832<sup>b</sup> (Gray)  
 of Servant of Jehovah. 2739<sup>a</sup> (Hough)  
 of Son of God . . . . . 2827<sup>a</sup> (Stalker)  
 of Son of Man . . . . . 2829<sup>b</sup> (Stalker)  
 of Zoroastrianism . . . . . 3157<sup>a</sup> (Easton)  
 Messianic Prophecy  
 of Maccabees, Books of . . . . . 1949<sup>b</sup> (T. W. Davies)  
 Metal . . . . . 2044<sup>a</sup> (Masterman)  
 of Electrum . . . . . 927<sup>b</sup> (Fortune)  
 of Stones, Precious . . . . . 2856<sup>a</sup> (Fletcher)  
 Metallurgy . . . . . 2044<sup>a</sup> (Patch)  
 of Refiner, Refining . . . . . 2545<sup>a</sup> (Patch)  
 Metals . . . . . 2044<sup>a</sup> (Patch)  
 of Gold . . . . . 1274<sup>a</sup> (Patch)  
 of Iron . . . . . 1492<sup>a</sup> (Patch)  
 of Lead . . . . . 1861<sup>a</sup> (Patch)  
 of Mine, Mining . . . . . 2056<sup>b</sup> (Patch)  
 Metal Working  
 of Crafts . . . . . 734<sup>a</sup> (Patch)  
 of Mine, Mining . . . . . 2056<sup>b</sup> (Patch)  
 Mete . . . . . 2044<sup>b</sup> (Porter)  
 of Measure, Measures. 2016<sup>a</sup> (Porter)  
 Meterus  
 of Baiterus . . . . . 378<sup>a</sup>  
 Meteyard . . . . . 2045<sup>a</sup>  
 Metheg-ammah . . . . . 2045<sup>a</sup> (Porter)  
 Methusael  
 of Methushael . . . . . 2045<sup>a</sup>  
 Methuselah . . . . . 2045<sup>a</sup>; 139<sup>a</sup> (Davis)  
 Methushael . . . . . 2045<sup>a</sup>  
 Meunim  
 of Maon . . . . . 1984<sup>a</sup> (Ewing)  
 of Simeon . . . . . 2793<sup>a</sup> (Masterman)  
 Meuzal . . . . . 2045<sup>a</sup>  
 of Uzal . . . . . 3042<sup>b</sup> (Fulton)  
 Me-zahab . . . . . 2045<sup>a</sup>  
 Mezarim (North)  
 of Astronomy . . . . . 300<sup>b</sup> (Maunder)  
 Mezobaite . . . . . 2045<sup>a</sup>  
 Miamin  
 of Mijamin . . . . . 2051<sup>a</sup>  
 of Miniamin . . . . . 2057<sup>a</sup>  
 Mibhar . . . . . 2045<sup>a</sup>  
 Mibsam . . . . . 2045<sup>b</sup>  
 Mibzar . . . . . 2045<sup>b</sup>  
 Mica (Micha) . . . . . 2045<sup>b</sup>  
 of Micah . . . . . 2046<sup>a</sup> (Lees)  
 of Micaiah . . . . . 2047<sup>a</sup> (Lees)  
 Micah (general) . . . . . 2045<sup>b</sup> (Lees)  
 of Dan . . . . . 781<sup>a</sup> (Ewing)  
 of Judges, Book of . . . . . 1772<sup>a</sup> (Geden)  
 of Priesthood . . . . . 2444<sup>a</sup> (Moorehead)  
 Micah, Book of . . . . . 2046<sup>b</sup> (Orelli)  
 Contents of prophecies. 2046<sup>b</sup>  
 Form of the prophecies. 2046<sup>b</sup>  
 Relation to Isaiah . . . . . 2046<sup>b</sup>  
 Micah (prophet) . . . . . 2046<sup>a</sup> (Orelli)  
 Name and person . . . . . 2046<sup>a</sup>  
 Time of . . . . . 2046<sup>a</sup>  
 Micaiah . . . . . 2047<sup>a</sup> (Lees)  
 of Maacah . . . . . 1945<sup>a</sup> (Ewing)  
 of Mica (Micha) . . . . . 2045<sup>b</sup>  
 of Micah (prophet) . . . . . 2046<sup>a</sup> (Orelli)  
 Mice  
 of Mouse . . . . . 2092<sup>b</sup> (Day)  
 Micha, Michah  
 of Mica . . . . . 2045<sup>b</sup>  
 of Micah (general) . . . . . 2045<sup>b</sup> (Lees)  
 Michael . . . . . 2047<sup>b</sup> (Lees)  
 Reference to, in Ep. of Jude . . . . . 1770<sup>a</sup> (Moorehead)  
 Michah  
 of Micah (general) . . . . . 2045<sup>b</sup> (Lees)  
 Michaiiah  
 of Micaiah . . . . . 2047<sup>a</sup> (Lees)  
 Michal . . . . . 2048<sup>a</sup> (Lees)  
 Micheas (Michaeas) . . . . . 2048<sup>a</sup>  
 Michmas . . . . . 2048<sup>a</sup>  
 of Macalon . . . . . 1946<sup>a</sup>  
 Michmash . . . . . 2048<sup>a</sup> (Ewing)  
 Camp of Saul . . . . . 2048<sup>a</sup>  
 of Geba . . . . . 1180<sup>a</sup> (Ewing)  
 Identification . . . . . 2048<sup>b</sup>  
 Later notices . . . . . 2048<sup>b</sup>  
 of Seneh . . . . . 2720<sup>a</sup> (Ewing)  
 Michmethah . . . . . 2049<sup>a</sup>  
 Michri . . . . . 2049<sup>a</sup>  
 Michtam  
 of Psalms, Book of . . . . . 2487<sup>a</sup> (Sampey)  
 Midday . . . . . 2049<sup>a</sup>  
 of Noon, Noonday . . . . . 2155<sup>a</sup>  
 Middin . . . . . 2049<sup>a</sup>  
 Middle Wall  
 of Partition . . . . . 2253<sup>a</sup> (Rutherford)  
 Midian, Midianites . . . . . 2049<sup>a</sup> (Ewing)  
 of Defeat of, by Gideon. 1227<sup>b</sup> (Schenk)  
 Historical references . . . . . 2049<sup>b</sup>  
 of Jethro . . . . . 1674<sup>b</sup> (Crichton)  
 Kenite branch . . . . . 2049<sup>b</sup>  
 of Kenites . . . . . 1792<sup>a</sup> (Ewing)  
 Modern Arabs . . . . . 2049<sup>b</sup>  
 Origin . . . . . 2049<sup>a</sup>  
 Midianitish Woman . . . . . 2049<sup>b</sup> (Lees)  
 Midnight . . . . . 2050<sup>a</sup> (Porter)  
 of Time . . . . . 2981<sup>b</sup> (Porter)  
 Midrash . . . . . 2050<sup>b</sup>; 685<sup>a</sup> (Oko)  
 of Commentary . . . . . 687<sup>a</sup> (M. O. Evans)

- Midwife . . . . . 2050<sup>a</sup> (Macalister)  
 Migdal-eder  
   of Eder . . . . . 899<sup>a</sup> (Masterman)  
 Migdal-el . . . . . 2050<sup>a</sup>  
 Migdal-gad . . . . . 2050<sup>b</sup> (Masterman)  
 Migdol . . . . . 2050<sup>b</sup> (Conder)  
   of Exodus, The . . . . . 1052<sup>a</sup> (Conder)  
   of Shur . . . . . 2782<sup>a</sup> (Conder)  
 Migration  
   Influence on family . . . . . 1096<sup>b</sup>  
 Migron . . . . . 2051<sup>b</sup> (Ewing)  
 Mijamin (Miamin) . . . . . 2051<sup>a</sup>  
   of Miniamin . . . . . 2057<sup>a</sup>  
 Mikloth . . . . . 2051<sup>a</sup>  
 Mikneiah . . . . . 2051<sup>a</sup>  
 Milalai . . . . . 2051<sup>a</sup>  
 Milcah . . . . . 2051<sup>a</sup>  
 Milcom (Malcam)  
   of Molech . . . . . 2074<sup>a</sup> (Nicol)  
 Mildew . . . . . 2051<sup>b</sup> (Masterman)  
   of Blasting . . . . . 486<sup>a</sup> (Patch)  
 Mile . . . . . 2051<sup>b</sup>  
   of Weights and Measures . . . . . 3079<sup>a</sup> (Porter)  
 Miletus . . . . . 2051<sup>b</sup> (Banks)  
   of Samos . . . . . 2674<sup>b</sup> (Kinsella)  
 Milk . . . . . 2051<sup>b</sup> (N. Isaacs)  
   of Food . . . . . 1123<sup>b</sup> (Eager)  
 Mill, Millstone . . . . . 2052<sup>a</sup> (Patch)  
   of Agriculture . . . . . 77<sup>b</sup> (Patch)  
   of Crafts . . . . . 734<sup>a</sup> (Patch)  
   of Food . . . . . 1121<sup>b</sup> (Eager)  
 Millennium (Postmillennial View)  
   of Eschatology of the NT . . . . . 979<sup>b</sup> (Vos)  
 Millennium (Premillennial View) . . . . . 2052<sup>b</sup> (Moorehead)  
   of Parousia . . . . . 2249<sup>a</sup> (Easton)  
   Teaching of apostles . . . . . 2054<sup>a</sup>  
   Teaching of Jesus . . . . . 2053<sup>a</sup>  
 Millet . . . . . 2055<sup>a</sup> (Masterman); 1122<sup>a</sup>  
   (Eager)  
 Millo . . . . . 2055<sup>a</sup> (Masterman)  
   Akra site, the . . . . . 2055<sup>b</sup>  
   Beth-millo . . . . . 2055<sup>a</sup>  
   of Jerusalem Hills . . . . . 1599<sup>b</sup> (Masterman)  
   of Jerusalem, History  
     of . . . . . 1613<sup>b</sup> (Masterman)  
   of Jerusalem Walls . . . . . 1602<sup>b</sup> (Masterman)  
   OT references . . . . . 2055<sup>a</sup>  
   of Solomon . . . . . 2824<sup>a</sup> (Weir)  
 Millstone  
   of Mill . . . . . 2052<sup>a</sup> (Patch)  
 Mina  
   of Maneh . . . . . 1981<sup>a</sup> (Porter)  
 Mincing . . . . . 2055<sup>b</sup>  
 Mind . . . . . 2056<sup>a</sup> (Marais)  
   Dianoia and nous . . . . . 2056<sup>a</sup>  
   Ethical sense . . . . . 2055<sup>a</sup>  
   Reference in Luke 10 27 . . . . . 2055<sup>b</sup>  
   Terms used not precise 2056<sup>a</sup>
- Mine, Mining . . . . . 2056<sup>b</sup> (Patch)  
   of Crafts . . . . . 734<sup>a</sup> (Patch)  
   of Metals . . . . . 2044<sup>a</sup> (Patch)  
 Minerals  
   of Metals . . . . . 2044<sup>a</sup> (Patch)  
   of Stones, Precious . . . . . 2856<sup>a</sup> (Fletcher)  
 Mingled People (Mixed  
   Multitude) . . . . . 2056<sup>b</sup> (Easton)  
   of Samaria, City . . . . . 2671<sup>a</sup> (Ewing)  
   of Samaria, Country . . . . . 2672<sup>b</sup> (Ewing)  
 Miniamin . . . . . 2057<sup>a</sup>  
   of Mijamin . . . . . 2051<sup>a</sup>  
 Minish . . . . . 2057<sup>a</sup>  
 Ministry . . . . . 2057<sup>a</sup> (T. M. Lindsay)  
   of Bishop . . . . . 478<sup>b</sup> (Dosker)  
   of Church Government 653<sup>b</sup> (Forrester)  
   of Deacon . . . . . 800<sup>a</sup> (Heidel)  
   of Elder, OT and NT . . . . . 923<sup>b</sup> (Stearns); 924<sup>a</sup>  
     (Grant)  
   of Hands, Imposition of 1335<sup>a</sup> (Orr)  
   of Pastor . . . . . 2258<sup>b</sup>  
   of Pauline Theology . . . . . 2292<sup>a</sup> (Easton)  
   Threefold congregational ministry . . . . . 2060<sup>b</sup>  
   Bishops and presbyters . . . . . 2061<sup>a</sup>  
   Growth of orders . . . . . 2061<sup>b</sup>  
   Insistence on organization . . . . . 2060<sup>b</sup>  
   Synods . . . . . 2062<sup>a</sup>  
   Two different kinds of 2057<sup>b</sup>  
   Apostles . . . . . 2058<sup>a</sup>  
   Local ministry, the . . . . . 2059<sup>a</sup>  
   Origins of local ministry . . . . . 2059<sup>b</sup>  
   Prophetic ministry . . . . . 2058<sup>a</sup>  
   Prophets . . . . . 2058<sup>b</sup>  
   Use of the word . . . . . 2057<sup>a</sup>  
 Minni . . . . . 2062<sup>a</sup>  
 Minnith . . . . . 2062<sup>a</sup> (Ewing)  
 Minstrel  
   of Music . . . . . 2094<sup>b</sup> (Millar)  
 Mint . . . . . 2062<sup>b</sup>  
 Miphkad, Gate of . . . . . 2062<sup>b</sup>  
   of Jerusalem . . . . . 1607<sup>a</sup> (Masterman)  
 Miracle . . . . . 2062<sup>b</sup> (Wace)  
   Biblical terms . . . . . 2062<sup>b</sup>  
   Ecclesiastical miracles . . . . . 2065<sup>b</sup>  
   Evidential value of . . . . . 2064<sup>a</sup>  
   In the Gospels . . . . . 2063<sup>a</sup>  
   of Jericho . . . . . 1592<sup>a</sup> (Wright)  
   of Jesus Christ . . . . . 1629<sup>a</sup> (Orr)  
   Laws of Nature and . . . . . 2063<sup>b</sup>  
   Nature of miracle . . . . . 2062<sup>b</sup>  
   In OT . . . . . 2065<sup>a</sup>  
   of Plagues of Egypt . . . . . 2405<sup>b</sup> (Kyle)  
   of Red Sea . . . . . 2540<sup>b</sup> (Wright)  
   of Sign . . . . . 2789<sup>a</sup> (Stuart)  
   In works of grace . . . . . 2065<sup>b</sup>  
 Miracles, Gift of  
   of Miracle . . . . . 2062<sup>b</sup> (Wace)  
   of Spiritual Gifts . . . . . 2843<sup>a</sup> (Lambert)

- Mirage . . . . . 2066<sup>a</sup> (Joy)  
 of Parched . . . . . 2247<sup>b</sup> (Patch)
- Mire  
 of Chalkstone . . . . . 591<sup>a</sup> (Day)  
 of Clay . . . . . 667<sup>a</sup> (Day)  
 of Marsh . . . . . 2000<sup>a</sup> (Day)
- Miriam . . . . . 2066<sup>a</sup> (Lees)  
 of Mary (name) . . . . . 2001<sup>a</sup> (Sweet)  
 of Moses . . . . . 2088<sup>a</sup> (Kyle)
- Mirmah . . . . . 2066<sup>a</sup>
- Mirror  
 of Looking-glass . . . . . 1919<sup>a</sup>
- Misael (Apoc) . . . . . 2066<sup>a</sup>
- Misaias (Masias) . . . . . 2006<sup>b</sup>
- Mischief . . . . . 2066<sup>b</sup>
- Misgab . . . . . 2066<sup>b</sup>
- Mishael . . . . . 2066<sup>b</sup>  
 of Meshach . . . . . 2038<sup>a</sup> (R. D. Wilson)
- Mishal . . . . . 2066<sup>b</sup>
- Misham . . . . . 2066<sup>b</sup>
- Misheal  
 of Mishal . . . . . 2066<sup>b</sup>
- Mishma . . . . . 2066<sup>b</sup>
- Mishmannah . . . . . 2066<sup>b</sup>
- Mishna  
 of Talmud . . . . . 2905<sup>a</sup> (Strack)
- Mishneh . . . . . 2066<sup>b</sup> (Masterman)  
 of College . . . . . 674<sup>a</sup>  
 of Jerusalem . . . . . 1607<sup>a</sup> (Masterman)  
 of Maktesh, The . . . . . 1969<sup>a</sup> (Masterman)
- Mishor . . . . . 2067<sup>a</sup>  
 of Plain . . . . . 2406<sup>b</sup> (Day)
- Mishraites . . . . . 2067<sup>a</sup>
- Mispar (Mispereth) . . . . . 2067<sup>a</sup>
- Misrephoth-maim . . . . . 2067<sup>a</sup> (Porter)  
 of Ladder of Tyre . . . . . 1821<sup>a</sup> (Porter)  
 of Zarephath . . . . . 3132<sup>b</sup> (Ewing)
- Mist . . . . . 2067<sup>a</sup> (Joy)  
 of Vapor . . . . . 3046<sup>a</sup> (Day)
- Mistress . . . . . 2067<sup>a</sup>
- Mite . . . . . 2067<sup>b</sup> (Porter)  
 of Money . . . . . 2079<sup>a</sup> (Porter)
- Mithkah (Mithcah) . . . . . 2067<sup>a</sup>  
 of Wanderings of Israel . . . . . 3064<sup>a</sup> (Conder)
- Mithnite . . . . . 2067<sup>b</sup>
- Mithra  
 of Persian Religion (Ancient) . . . . . 2333<sup>b</sup> (Tisdall)
- Mithradates (Mithradates) . . . . . 2067<sup>b</sup>
- Mithredath . . . . . 2067<sup>b</sup>  
 of Mithradates . . . . . 2067<sup>b</sup>
- Mitre . . . . . 2067<sup>b</sup> (T. Lewis)  
 of Priests and Levites . . . . . 2452<sup>a</sup> (Wiener)
- Mitylene . . . . . 2068<sup>a</sup> (Harry)
- Mixed Multitude  
 of Mingled People . . . . . 2056<sup>b</sup> (Easton)
- Mizar, The Hill . . . . . 2068<sup>a</sup> (Ewing)
- Mizpah, Mizpeh . . . . . 2068<sup>a</sup> (Ewing)  
 of Ramah . . . . . 2528<sup>a</sup> (Ewing)  
 of Ramath-mizpeh . . . . . 2529<sup>a</sup>
- Mizpah, Mizpeh—*continued*  
 of Ramoth-gilead . . . . . 2529<sup>a</sup> (Ewing)  
 of Watchtower . . . . . 3074<sup>a</sup>
- Mizpar (Mispar) . . . . . 2067<sup>a</sup>
- Mizraim . . . . . 2069<sup>a</sup> (Kyle)  
 of Africa . . . . . 68<sup>a</sup> (Pinches)  
 of Egypt . . . . . 906<sup>a</sup> (Petrie)  
 of Ham, Land of . . . . . 1324<sup>b</sup> (Ewing)  
 of Table of Nations . . . . . 2898<sup>b</sup> (Pinches)
- Mizzah . . . . . 2069<sup>b</sup>
- Mnason . . . . . 2069<sup>b</sup> (S. F. Hunter)
- Moab, Moabites . . . . . 2069<sup>b</sup> (Porter)  
 History . . . . . 2070<sup>b</sup>  
 of Jehoram . . . . . 1580<sup>b</sup> (Mosiman)  
 Land, the . . . . . 2069<sup>b</sup>  
 of Moabites . . . . . 2072<sup>b</sup>  
 People, the . . . . . 2070<sup>b</sup>  
 of Plain of Moab . . . . . 2407<sup>a</sup>  
 Religion . . . . . 2070<sup>b</sup>
- Moabite Stone . . . . . 2071<sup>b</sup> (Sayce); 80<sup>a</sup> (Mosiman); 601<sup>b</sup> (Nicol)  
 of Ahab . . . . . 78<sup>b</sup> (Mosiman)  
 Discovery . . . . . 2071<sup>b</sup>  
 Inscription . . . . . 2072<sup>a</sup>  
 of Jehoram . . . . . 1580<sup>b</sup> (Mosiman)  
 Language of . . . . . 2072<sup>a</sup>  
 of Mesha . . . . . 2038<sup>a</sup> (Ewing)  
 of Palestine, Recent Exploration . . . . . 2224<sup>b</sup> (Cobern)
- Moabites . . . . . 2072<sup>b</sup>  
 of Moab . . . . . 2069<sup>b</sup> (Porter)
- Moadiah  
 of Maadiah . . . . . 1945<sup>b</sup>
- Mochmur, The Brook . . . . . 2072<sup>b</sup>
- Mock, Mocker, Mocking . . . . . 2072<sup>b</sup> (W. L. Walker)  
 of Laughing-stock . . . . . 1843<sup>b</sup>
- Modad, Book of Eldad  
 and . . . . . 923<sup>b</sup> (Fortune)
- Moderately . . . . . 2073<sup>a</sup> (W. L. Walker)
- Moderation . . . . . 2073<sup>a</sup>
- Modin (Apoc) . . . . . 2073<sup>a</sup> (Ewing)  
 Home of the Maccabees . . . . . 2073<sup>a</sup>  
 Identifications . . . . . 2073<sup>b</sup>  
 of Maccabaeus . . . . . 1946<sup>a</sup> (Hutchison)  
 Monument at . . . . . 2073<sup>b</sup>
- Moeth (Apoc) . . . . . 2073<sup>a</sup>  
 of Noadiah . . . . . 2153<sup>a</sup>
- Moladah . . . . . 2073<sup>b</sup>  
 of Salt, City of . . . . . 2664<sup>b</sup>
- Mole . . . . . 2074<sup>a</sup> (Day)  
 of Chameleon . . . . . 592<sup>a</sup> (Day)  
 of Lizard . . . . . 1906<sup>a</sup> (Day)  
 of Weasel . . . . . 3076<sup>b</sup> (Day)
- Molech, Moloch . . . . . 2074<sup>a</sup> (Nicol)  
 of Fire . . . . . 1112<sup>a</sup> (W. L. Walker)  
 of Gehenna . . . . . 1183<sup>a</sup> (Vos)  
 of Gods . . . . . 1271<sup>a</sup> (Reeve)  
 of Malcam . . . . . 1971<sup>a</sup>  
 Name . . . . . 2074<sup>a</sup>  
 Nature of the worship . . . . . 2075<sup>a</sup>

- Molech, Moloch—*continued*  
 Origin of the worship. 2075<sup>b</sup>  
 OT references. 2074<sup>b</sup>  
 In the prophets. 2074<sup>b</sup>
- Moli  
 cf Mooli. 2081<sup>a</sup>
- Molid. 2075<sup>b</sup>
- Mollify. 2075<sup>b</sup>
- Moloch (Molech). 2075<sup>b</sup>; 2074<sup>a</sup>  
 cf Astrology. 295<sup>b</sup> (Maunder)  
 cf Semites, Semitic Religion. 2717<sup>a</sup> (Mack)
- Molten Image  
 cf Image. 1450<sup>a</sup> (Edwards)
- Molten Sea. 2708<sup>a</sup> (Caldecott)  
 cf Laver. 1843<sup>b</sup> (Caldecott)  
 cf Ledge. 1864<sup>b</sup>
- Momdis (Apoc). 2075<sup>b</sup>
- Moment. 2076<sup>a</sup> (Porter)
- Monarchianism. 627<sup>a</sup> (Orr)
- Money. 2076<sup>a</sup> (Porter)  
 Coined money. 2076<sup>b</sup>  
 Coins of various kings 2077<sup>a</sup>  
 Herodian coins. 2079<sup>b</sup>  
 Maccabean coins. 2078<sup>a</sup>  
 Material and form. 2076<sup>a</sup>  
 cf Mite. 2067<sup>b</sup> (Porter)  
 cf Penny. 2298<sup>a</sup>  
 cf Piece of Gold. 2394<sup>b</sup>  
 cf Piece of Silver. 2395<sup>a</sup> (Porter)  
 Roman coins. 2079<sup>a</sup>  
 cf Shekel. 2758<sup>a</sup> (Porter)  
 cf Stater. 2850<sup>a</sup>  
 cf Talent. 2904<sup>a</sup> (Porter)  
 cf Time. 2981<sup>b</sup> (Porter)  
 cf Wedge of Gold. 3078<sup>b</sup> (Porter)  
 cf Weights and Measures. 3079<sup>a</sup> (Porter)  
 cf Writing. 3120<sup>b</sup> (Richardson)
- Money-changers. 2080<sup>b</sup> (Pollard)  
 cf Table. 2898<sup>a</sup> (Easton)
- Money, Current. 2081<sup>a</sup> (Betteridge)
- Money, Love of. 2081<sup>a</sup>  
 cf Covetousness. 733<sup>b</sup> (W. Evans)
- Money, Sin. 2802<sup>a</sup>  
 cf Sin Offering. 2644<sup>b</sup> (Reeve)
- Monogamy  
 cf Family. 1095<sup>a</sup> (Caverno)
- Monotheism  
 cf Johannine Theology 1701<sup>a</sup> (Law)
- Monster  
 cf Dragon. 873<sup>a</sup> (Day)  
 cf Sea Monster. 2707<sup>a</sup> (Day)
- Month. 2081<sup>a</sup> (Porter)  
 cf Astronomy. 300<sup>b</sup> (Maunder)  
 cf Calendar. 541<sup>b</sup> (Porter)  
 cf Time. 2981<sup>b</sup> (Porter)
- Monthly Prognosticators  
 cf Astrology. 295<sup>b</sup> (Maunder)
- Monument  
 cf Vault. 3046<sup>b</sup>
- Mooli (Apoc). 2081<sup>a</sup>
- Moon. 2081<sup>a</sup> (Schenk)  
 cf Astrology. 295<sup>b</sup> (Maunder)  
 cf Astronomy. 300<sup>b</sup> (Maunder)  
 cf Crescents. 744<sup>b</sup>
- Moon, New  
 cf Astronomy. 300<sup>b</sup> (Maunder)  
 cf Divination. 860<sup>a</sup> (T. W. Davies)  
 cf Feasts and Fasts. 1103<sup>a</sup> (E. D. Isaacs)  
 cf Sun, Smiting by. 2870<sup>b</sup> (Macalister)
- Moossias (Apoc). 2081<sup>b</sup>
- Moph  
 cf Memphis. 2030<sup>b</sup> (Petrie)
- Morality  
 cf Ethics. 1013<sup>a</sup> (Alexander)
- Morashtite. 2081<sup>b</sup>  
 cf Moreseth-gath. 2082<sup>a</sup> (Porter)
- Mordecai. 2081<sup>b</sup> (Urquhart)
- Moreh, Hill of. 2082<sup>a</sup> (Ewing)  
 cf Gibeath. 1225<sup>b</sup> (Ewing)
- Moreh, Oak of. 2082<sup>a</sup> (Ewing)  
 cf Meonenim, Oak of. 2033<sup>b</sup>
- Moreseth-gath. 2082<sup>a</sup> (Porter)  
 cf Morashtite. 2081<sup>b</sup>
- Moriah, Hill of  
 cf Gerizim, Mount. 1218<sup>a</sup> (Ewing)  
 cf Jerusalem Hills. 1599<sup>b</sup> (Masterman)
- Moriah, Land of. 2082<sup>b</sup> (Ewing)
- Morning. 2082<sup>b</sup> (Porter)  
 cf Betimes. 454<sup>a</sup> (Kinsella)  
 cf Hind of the Morning, The. 1393<sup>a</sup> (M. O. Evans)
- Morning Watch. 2083<sup>a</sup>  
 cf Watch. 3074<sup>a</sup> (Porter)
- Morning, Wings of  
 cf Astronomy. 300<sup>b</sup> (Maunder)
- Morrow, Tomorrow. 2083<sup>a</sup> (Porter)
- Morrow after the Sabbath. 2083<sup>a</sup> (Hirsch)
- Morsel. 2083<sup>a</sup>  
 cf Sop. 2836<sup>a</sup>
- Mortal, Mortality. 2083<sup>a</sup>  
 cf Immortal, Immortality. 1458<sup>b</sup> (Orr)
- Mortar. 2083<sup>a</sup> (Orr)  
 cf Bray. 514<sup>b</sup> (M. O. Evans)  
 cf Pestle. 2348<sup>b</sup>  
 cf Whitewash. 3083<sup>b</sup>
- Mortgage. 2083<sup>b</sup>  
 cf Surety. 2872<sup>a</sup> (Reeve)
- Mortify. 2083<sup>b</sup> (Easton)
- Moserah. 2083<sup>b</sup>
- Moseroth. 2083<sup>b</sup>  
 cf Wanderings of Israel 3064<sup>a</sup> (Conder)
- Moses. 2083<sup>b</sup> (Kyle)  
 cf Aaron. 1<sup>a</sup> (Mack)  
 cf Ark of Bulrushes. 242<sup>a</sup> (Kyle)  
 cf Assumption of. 169<sup>a</sup> (J. E. H. Thomson)  
 cf Authorship of Deuteronomy. 836<sup>b</sup> (Robinson)  
 cf Book of the Covenantant. 729<sup>b</sup> (Mack)

- Moses—*continued*  
 of Brazen Serpent (Ne-  
 hushtan) . . . . . 2132<sup>a</sup> (Longacre)  
 of Burning Bush . . . . . 532<sup>b</sup> (Kyle)  
 of Caleb . . . . . 541<sup>a</sup> (Margolis)  
 of Calif. Golden . . . . . 298<sup>a</sup> (Maunder)  
 of Claimed as author  
 of Genesis . . . . . 1212<sup>a</sup> (Möller)  
 Commissioned as  
 leader . . . . . 2085<sup>a</sup>  
 Conflict with the Pha-  
 raohs . . . . . 2085<sup>b</sup>  
 Crossing the sea . . . . . 2086<sup>b</sup>  
 of Deuteronomy . . . . . 835<sup>b</sup> (Robinson)  
 Efforts at deliverance . 2084<sup>b</sup>  
 Exodus, the . . . . . 2086<sup>a</sup>  
 of Exodus, The . . . . . 1052<sup>a</sup> (Conder)  
 Faith of . . . . . 2088<sup>a</sup>  
 Final acts . . . . . 2088<sup>a</sup>  
 Genealogy . . . . . 2084<sup>a</sup>  
 Infancy and youth . . . 2084<sup>a</sup>  
 of Intercessions of . . . 1485<sup>a</sup> (Bevan)  
 of Israel, Religion of . . 1534<sup>b</sup> (Orelli)  
 of Joshua (son of Nun) . 1744<sup>a</sup> (Geden)  
 Journey to Canaan . . . 2088<sup>a</sup>  
 Lawgiver . . . . . 2090<sup>a</sup>  
 Law received . . . . . 2087<sup>a</sup>  
 of Leadership of Israel . 1515<sup>a</sup> (Orelli)  
 of Leviticus . . . . . 1870<sup>a</sup> (Möller)  
 of Manna . . . . . 1982<sup>a</sup> (Masterman)  
 of Miriam . . . . . 2066<sup>a</sup> (Lees)  
 of Moses and Hammu-  
 rabi . . . . . 1331<sup>b</sup> (Ungnad)  
 Moses, Law of . . . . . 2089<sup>b</sup>  
 of Numbers, Book of . . 2169<sup>a</sup> (Whitelaw)  
 Obscurity of doctrine  
 of resurrection . . . . . 2089<sup>b</sup>  
 Passover, the . . . . . 2085<sup>b</sup>  
 of Pentateuch . . . . . 2298<sup>a</sup> (Wiener)  
 As prophet . . . . . 2091<sup>a</sup>  
 of Punishment of Korah . 1816<sup>b</sup> (Beecher)  
 of Quail . . . . . 2512<sup>a</sup> (Stratton-Porter)  
 Refugee in Midian . . . 2084<sup>b</sup>  
 of Sinai . . . . . 2802<sup>b</sup> (Conder)  
 Special providences . . . 2087<sup>a</sup>  
 Tabernacle made . . . . 2087<sup>b</sup>  
 of Tell el-Amarna Tab-  
 lets . . . . . 2928<sup>a</sup> (Kyle)  
 As toiler . . . . . 2088<sup>b</sup>  
 Traditions regarding . . 2089<sup>a</sup>  
 Unity of Pentateuch . . 2089<sup>b</sup>  
 of Wanderings of Israel . 3064<sup>a</sup> (Conder)  
 Work and character . . . 2088<sup>b</sup>  
 Moses, Assumption of  
 of Apocalyptic Litera-  
 ture . . . . . 161<sup>b</sup> (J. E. H. Thomson)  
 Moses, Song of . . . . . 2091<sup>a</sup> (Orr)  
 Mosollamon  
 of Mosollamus (Apoc) . 2091<sup>b</sup>  
 Mosollamus (Apoc) . . . 2091<sup>b</sup>  
 Most High, Most Holy  
 of God, Names of . . . . 1266<sup>b</sup>; 1267<sup>a</sup> (Mack)
- Mote . . . . . 2091<sup>b</sup>  
 Moth . . . . . 2091<sup>b</sup> (Day)  
 of Insects . . . . . 1473<sup>a</sup> (Day)  
 of Worm . . . . . 3109<sup>a</sup> (Day)  
 Mother . . . . . 2092<sup>a</sup> (Dosker)  
 of Family . . . . . 1095<sup>b</sup> (Caverno)  
 Mother-in-Law  
 of Relationships, Fam-  
 ily . . . . . 2556<sup>a</sup> (N. and E. D.  
 Isaacs)  
 Motion . . . . . 2092<sup>b</sup> (Easton)  
 Mound  
 of Siege . . . . . 2787<sup>a</sup> (Nicol)  
 Mount, Mountain  
 of High Place . . . . . 1390<sup>a</sup> (Easton)  
 of Hill, Mount, Moun-  
 tain . . . . . 1392<sup>b</sup> (Day)  
 Mount of the Amale-  
 kites . . . . . 2092<sup>b</sup>  
 of Amalekites . . . . . 112<sup>b</sup> (Porter)  
 Mount of the Amorites . 2092<sup>b</sup>  
 of Amorites . . . . . 119<sup>a</sup> (Sayce)  
 Mount of Congregation,  
 The . . . . . 701<sup>a</sup> (Orr)  
 Mount of Corruption  
 of Olives, Mount of . . . 2185<sup>b</sup> (Masterman)  
 Mount Ephraim . . . . . 963<sup>b</sup>  
 Mount Halak . . . . . 1322<sup>a</sup> (Ewing)  
 Mount of Olives . . . . . 2185<sup>b</sup> (Masterman)  
 of Jerusalem . . . . . 1598<sup>b</sup> (Masterman)  
 Mount Seir  
 of Simeon . . . . . 2794<sup>a</sup> (Masterman)  
 Mount of Sodom . . . . . 808<sup>b</sup> (Wright)  
 Mount of the Valley . . . 2092<sup>b</sup>  
 Mourning  
 of Burial . . . . . 529<sup>a</sup> (Eager)  
 of Grief . . . . . 1305<sup>b</sup> (W. L. Walker)  
 Mouse, Mice . . . . . 2092<sup>b</sup> (Day)  
 Mouth . . . . . 2093<sup>a</sup> (Luering)  
 of Lip . . . . . 1896<sup>a</sup> (Luering)  
 of Tongue . . . . . 2994<sup>b</sup> (Easton)  
 Mowing, Mown Grass . . 2093<sup>a</sup> (M. O. Evans)  
 of Harvest . . . . . 1341<sup>b</sup> (Patch)  
 of Reaping . . . . . 2534<sup>a</sup> (Patch)  
 Moza . . . . . 2093<sup>b</sup>  
 Mozah . . . . . 2093<sup>b</sup>  
 Muffler . . . . . 2093<sup>b</sup>  
 of Dress . . . . . 875<sup>b</sup> (Eager)  
 of Veil . . . . . 3047<sup>a</sup> (Easton)  
 Mulberry Trees, Mul-  
 berry . . . . . 2093<sup>b</sup> (Masterman)  
 of Acacia . . . . . 27<sup>a</sup> (Masterman)  
 of Food . . . . . 1123<sup>a</sup> (Eager)  
 of Poplar . . . . . 2421<sup>b</sup> (Masterman)  
 of Sycamore . . . . . 2876<sup>a</sup> (Masterman)  
 Mulcted . . . . . 2093<sup>b</sup>  
 Mule . . . . . 2093<sup>b</sup> (Day)  
 Multitude, Mixed  
 of Mingled People . . . 2056<sup>b</sup> (Easton)  
 Munition  
 of Siege . . . . . 2786<sup>a</sup> (Nicol)

- Muppim . . . . . 2094<sup>a</sup>  
 of Shephupham . . . . . 2764<sup>a</sup>  
 of Shuppim . . . . . 2782<sup>a</sup>
- Murder . . . . . 2094<sup>a</sup> (Hirsch)  
 of Goel . . . . . 1272<sup>b</sup> (Breslich)  
 of Law in NT . . . . . 1845<sup>a</sup> (M'Caig)  
 of Manslaughter . . . . . 1983<sup>b</sup> (Hirsch)  
 of Manslayer . . . . . 1983<sup>b</sup> (Hirsch)
- Murderers . . . . . 2094<sup>a</sup> (Nicol)  
 of Assassins . . . . . 288<sup>a</sup> (S. F. Hunter)
- Murmur, Murmurings . . . . . 2094<sup>b</sup> (T. Lewis)
- Murrain . . . . . 2094<sup>b</sup> (Macalister)
- Muse, Musing . . . . . 2094<sup>b</sup>
- Mushi . . . . . 2094<sup>b</sup>
- Music . . . . . 2094<sup>b</sup> (Millar)  
 of Asaph . . . . . 262<sup>b</sup> (Millar)  
 Emotional range . . . . . 2095<sup>a</sup>  
 of Horn . . . . . 1422<sup>a</sup> (Easton)  
 of Hymn . . . . . 1445<sup>a</sup> (Millar)  
 Illustrations, mural . . . . . 2095<sup>b</sup>  
 Importance of . . . . . 2095<sup>a</sup>  
 Instruments . . . . . 2096<sup>b</sup>  
 of Instruments of  
 Music . . . . . 1484<sup>a</sup>  
 of Lute . . . . . 1942<sup>a</sup>  
 of Melody . . . . . 2029<sup>b</sup>  
 Musical theory . . . . . 2096<sup>a</sup>  
 Percussion instruments . . . . . 2101<sup>a</sup>  
 Place in social life . . . . . 2095<sup>a</sup>  
 Place in worship . . . . . 2095<sup>b</sup>  
 of Singers, Singing . . . . . 2804<sup>b</sup> (Millar)  
 Stringed instruments . . . . . 2097<sup>a</sup>  
 of Viol . . . . . 3051<sup>a</sup>  
 Wind instruments . . . . . 2099<sup>b</sup>
- Musical Instruments . . . . . 2101<sup>b</sup>
- Musician, Chief  
 of Asaph . . . . . 262<sup>b</sup> (Millar)  
 of Music . . . . . 2094<sup>b</sup> (Millar)  
 of Psalms, Book of . . . . . 2487<sup>a</sup> (Sampey)
- Mustard . . . . . 2101<sup>b</sup> (Masterman); 1124<sup>a</sup>  
 (Eager)
- Muth-labben . . . . . 2102<sup>a</sup>  
 of Psalms, Book of . . . . . 2487<sup>a</sup> (Sampey)
- Mutilation  
 of Punishments . . . . . 2504<sup>b</sup> (Hirsch)
- Mutter . . . . . 2102<sup>a</sup> (Easton)  
 of Peep . . . . . 2295<sup>a</sup>
- Muzzle . . . . . 2102<sup>a</sup> (T. Lewis)
- Myndus . . . . . 2102<sup>b</sup> (Banks)
- Myra . . . . . 2102<sup>b</sup> (Banks)  
 of Patara . . . . . 2262<sup>b</sup> (Banks)
- Myrrh . . . . . 2102<sup>b</sup> (Masterman)  
 of Balsam . . . . . 381<sup>b</sup> (Macalister)  
 of Botany . . . . . 505<sup>a</sup> (Masterman)  
 of Spice, Spices . . . . . 2840<sup>a</sup> (Masterman)  
 of Stacte . . . . . 2847<sup>b</sup>
- Myrtle . . . . . 2103<sup>b</sup> (Masterman)  
 of Esther, Book of . . . . . 1006<sup>a</sup> (Urquhart)  
 of Thick Trees . . . . . 2972<sup>a</sup>
- Mysia . . . . . 2103<sup>b</sup> (Banks)
- Mysteries  
 In ancient Greece . . . . . 1303<sup>a</sup> (Fairbanks)
- Mystery . . . . . 2104<sup>a</sup> (Edwards)  
 Ancient pagan reli-  
 gions . . . . . 2104<sup>a</sup>  
 Chief features of pa-  
 ganism . . . . . 2104<sup>a</sup>  
 NT references . . . . . 2104<sup>b</sup>  
 OT and Apocrypha . . . . . 2104<sup>b</sup>  
 Pagan mysteries and  
 the NT . . . . . 2105<sup>b</sup>  
 of Paul . . . . . 2275<sup>b</sup> (A. T. Robertson)  
 of Seal . . . . . 2709<sup>a</sup> (Edwards)  
 of Tongues, Gift of . . . . . 2996<sup>a</sup> (Easton)
- Mythology  
 of Babylonia and As-  
 syria, Religion of . . . . . 368<sup>b</sup> (Rogers)  
 of Fable . . . . . 1085<sup>a</sup> (Easton)  
 of Greece, Religion in . . . . . 1297<sup>b</sup> (Fairbanks)
- Naam . . . . . 2106<sup>a</sup>  
 Naamah (persons) . . . . . 2106<sup>a</sup>  
 Naamah (place) . . . . . 2106<sup>a</sup>  
 of Naamathite . . . . . 2106<sup>b</sup>  
 Naaman . . . . . 2106<sup>a</sup> (Lees)  
 of Naamite . . . . . 2106<sup>b</sup>  
 Naamathite . . . . . 2106<sup>b</sup>  
 of Naamah (place) . . . . . 2106<sup>a</sup>  
 Naamite . . . . . 2106<sup>b</sup>  
 of Naaman . . . . . 2106<sup>b</sup> (Lees)  
 Naarah (person) . . . . . 2106<sup>b</sup>  
 Naarah (place) . . . . . 2107<sup>a</sup>  
 Naarai (Paarai) . . . . . 2206<sup>a</sup>  
 Naaran (Naarath)  
 of Naarah (place) . . . . . 2107<sup>a</sup>  
 Naashon, Naason, Naas-  
 son  
 of Nahshon . . . . . 2109<sup>b</sup>  
 Naathus . . . . . 2107<sup>a</sup>  
 Nabaioth (Nebaioth) . . . . . 2126<sup>b</sup> (Fulton)  
 Nabal . . . . . 2107<sup>a</sup> (W. W. Davies); 9<sup>b</sup>  
 (Mack)
- Nabarias . . . . . 2107<sup>a</sup>
- Nabataeans, Nabathae-  
 ans . . . . . 2107<sup>b</sup> (Angus); 218<sup>a</sup> (Weir)  
 Early history . . . . . 2107<sup>b</sup>  
 Locality . . . . . 2107<sup>b</sup>  
 Relations with the  
 Herods . . . . . 2107<sup>b</sup>  
 Relations with Rome . . . . . 2107<sup>b</sup>  
 Rise to power . . . . . 2107<sup>b</sup>
- Nabathites (Nabataeans) . . . . . 2107<sup>b</sup> (Angus)
- Naboth . . . . . 2108<sup>a</sup> (Wallace)  
 of Jezreel . . . . . 1677<sup>a</sup> (Ewing)
- Nabu . . . . . 371<sup>b</sup> (Rogers)
- Nabuchodonosor . . . . . 2108<sup>a</sup>  
 of Nebuchadnezzar . . . . . 2127<sup>b</sup> (R. D. Wilson)
- Nachon (Naeon) . . . . . 2108<sup>a</sup> (Masterman)
- Nachor . . . . . 2108<sup>b</sup>  
 of Nahor . . . . . 2109<sup>b</sup>
- Naeon, Threshing Floor  
 of . . . . . 2108<sup>a</sup> (Masterman)
- Nadab . . . . . 2108<sup>b</sup> (Lees)
- Nadabath . . . . . 2108<sup>b</sup>

Naggai . . . . . 2108<sup>b</sup>  
 cf Nogah . . . . . 2154<sup>b</sup>  
 Nahalal . . . . . 2108<sup>b</sup> (Ewing)  
 Nahaliel . . . . . 2109<sup>a</sup>  
 Nahallal (Nahalol)  
 cf Nahalal . . . . . 2108<sup>b</sup> (Ewing)  
 Naham . . . . . 2109<sup>a</sup>  
 Nahamani . . . . . 2109<sup>a</sup>  
 Naharai, Nahari . . . . . 2109<sup>a</sup>  
 Nahash . . . . . 2109<sup>a</sup> (W. W. Davies)  
 cf Jesse . . . . . 1623<sup>a</sup> (Roberts)  
 Nahath . . . . . 2109<sup>b</sup>  
 Nahbi . . . . . 2109<sup>b</sup>  
 Nahor . . . . . 2109<sup>b</sup>  
 Nahshon . . . . . 2109<sup>b</sup>  
 Nahum (Naum) . . . . . 2122<sup>b</sup>; 2109<sup>b</sup>  
 Nahum, Book of . . . . . 2109<sup>b</sup> (Eiselen)  
 Contents . . . . . 2110<sup>a</sup>  
 Date . . . . . 2110<sup>a</sup>  
 Idea of God . . . . . 2110<sup>b</sup>  
 Integrity . . . . . 2110<sup>b</sup>  
 Life and home of Nahum . . . . . 2109<sup>b</sup>  
 Name . . . . . 2109<sup>b</sup>  
 Style . . . . . 2110<sup>b</sup>  
 Teaching of . . . . . 2110<sup>b</sup>  
 Naidus (Benaiah) . . . . . 2111<sup>a</sup>  
 Nail . . . . . 2111<sup>a</sup> (Orr)  
 cf Pare (the nails) . . . . . 2248<sup>b</sup>  
 Nain . . . . . 2111<sup>b</sup> (Ewing)  
 Naiioth . . . . . 2111<sup>b</sup> (Ewing)  
 Naked, Nakedness . . . . . 2111<sup>b</sup> (Easton)  
 cf Text of the OT . . . . . 2957<sup>b</sup> (Weir)  
 Name . . . . . 2112<sup>a</sup> (W. L. Walker)  
 Divine name . . . . . 2112<sup>a</sup>  
 cf God, Names of . . . . . 1264<sup>b</sup> (Mack)  
 cf Memorial . . . . . 2030<sup>b</sup> (W. L. Walker)  
 cf Names, Proper . . . . . 2113<sup>a</sup> (Davis)  
 NT usage . . . . . 2112<sup>b</sup>  
 OT usage . . . . . 2112<sup>a</sup>  
 Personal character in . . . . . 2112<sup>b</sup>  
 Relation to prayer . . . . . 2113<sup>a</sup>  
 Names of God . . . . . 1264<sup>b</sup> (Mack)  
 Names, Proper . . . . . 2113<sup>a</sup> (Davis)  
 Characteristics of Biblical references . . . . . 2116<sup>a</sup>  
 Allusions linked with names . . . . . 2116<sup>b</sup>  
 Coincidence and contrast . . . . . 2117<sup>a</sup>  
 Derivation . . . . . 2116<sup>a</sup>  
 Examples in Samuel and Reuben . . . . . 2116<sup>a</sup>  
 Narrator's interest . . . . . 2116<sup>a</sup>  
 Prophetic use of names . . . . . 2117<sup>b</sup>  
 Punning on names . . . . . 2116<sup>a</sup>  
 Form of Semitic names 2113<sup>a</sup>  
 Methods of abbreviation . . . . . 2114<sup>a</sup>  
 Transposition of the parts . . . . . 2114<sup>a</sup>

Names, Proper—*continued*

Form of Semitic names—*continued*  
 Types of names . . . . . 2113<sup>a</sup>  
 Vocalization . . . . . 2113<sup>b</sup>  
 cf God, Names of . . . . . 1264<sup>b</sup> (Mack)  
 cf Name . . . . . 2112<sup>a</sup> (W. L. Walker)  
 Range of proper names 2114<sup>b</sup>  
 Geographical names 2115<sup>b</sup>  
 Personal names . . . . . 2114<sup>b</sup>  
 Reasons for selection . . . . . 2115<sup>a</sup>  
 Wide range . . . . . 2114<sup>b</sup>  
 Nanaca (Nanea) . . . . . 2117<sup>b</sup> (Angus)  
 Naomi . . . . . 2118<sup>a</sup> (Roberts)  
 Naphath-dor  
 cf Dor . . . . . 869<sup>b</sup> (Porter)  
 Naphish . . . . . 2118<sup>a</sup>  
 cf Nephish . . . . . 2133<sup>b</sup>  
 cf Nephushesim . . . . . 2134<sup>a</sup>  
 Naphisi . . . . . 2118<sup>a</sup>  
 cf Naphish . . . . . 2118<sup>a</sup>  
 Naphoth-dor  
 cf Dor . . . . . 869<sup>b</sup> (Porter)  
 Naphtali (patriarch) . . . . . 2118<sup>b</sup> (Ewing)  
 Naphtali (tribe) . . . . . 2118<sup>b</sup> (Ewing)  
 Distinction . . . . . 2119<sup>a</sup>  
 cf Galilee . . . . . 1163<sup>a</sup> (Ewing)  
 Location in Palestine . . . . . 2118<sup>b</sup>  
 Modern sites and people . . . . . 2119<sup>b</sup>  
 Name and traditions . . . . . 2118<sup>b</sup>  
 cf Numbers, Book of . . . . . 2163<sup>a</sup> (Whitelaw)  
 Physical features of . . . . . 2119<sup>a</sup>  
 Position . . . . . 2118<sup>b</sup>  
 Transfiguration,  
 Mount of . . . . . 2119<sup>b</sup>; 3005<sup>b</sup> (Stuart)  
 Naphtali, Mount . . . . . 2119<sup>b</sup>  
 Naphthar (Nephthar) . . . . . 2133<sup>b</sup> (Angus)  
 Naphtuhim . . . . . 2119<sup>b</sup> (Lees)  
 Napkin . . . . . 2119<sup>b</sup>  
 cf Dress . . . . . 875<sup>b</sup> (Eager)  
 cf Handkerchief . . . . . 1334<sup>b</sup>  
 Narcissus . . . . . 2120<sup>a</sup> (S. F. Hunter)  
 Nard  
 cf Spikenard . . . . . 2840<sup>b</sup> (Masterman)  
 Nasbas . . . . . 2120<sup>a</sup> (Angus)  
 cf Achiacharus . . . . . 36<sup>a</sup>  
 cf Aman . . . . . 113<sup>a</sup>  
 Nasi (Nasith) . . . . . 2120<sup>a</sup>  
 Nasith (Neziah) . . . . . 2141<sup>a</sup>  
 Nasor  
 cf Hazor . . . . . 1347<sup>b</sup> (Ewing)  
 Nathan (general) . . . . . 2121<sup>a</sup> (Roberts)  
 cf Zabad . . . . . 3128<sup>a</sup> (Roberts)  
 Nathan (prophet) . . . . . 2120<sup>a</sup> (Roberts)  
 David's sin . . . . . 2120<sup>b</sup>  
 David's temple plans . . . . . 2120<sup>a</sup>  
 Solomon's accession . . . . . 2120<sup>b</sup>  
 Nathanael (apostle) . . . . . 2121<sup>a</sup> (Kerr)  
 cf Bartholomew . . . . . 406<sup>b</sup> (Kerr)  
 cf Matthias . . . . . 2012<sup>a</sup> (Kerr)



Nathanael (apostle)—*continued*  
 of Simon . . . . . 2795<sup>a</sup> (S. F. Hunter)  
 of Simon the Cana-  
 naean, or Zealot . . . 2797<sup>b</sup> (Kerr)  
 Nathanael (general) . . . 2121<sup>a</sup>  
 Nathanas . . . . . 2121<sup>b</sup>  
 Nathaniel  
 of James (son of Al-  
 phaesus) . . . . . 1561<sup>a</sup> (Kerr)  
 Nathan-melech . . . . . 2121<sup>b</sup>  
 Nations  
 of Gentiles . . . . . 1215<sup>a</sup> (Porter)  
 of Gooim . . . . . 1273<sup>a</sup>  
 of Table of Nations . . 2898<sup>b</sup> (Pinches)  
 of Tidal . . . . . 2980<sup>a</sup> (Pinches)  
 of World, Cosmologi-  
 cal . . . . . 3106<sup>a</sup> (Orr)  
 Nativity, Apocryphal  
 Gospel of . . . . . 198<sup>a</sup> (Hutchison)  
 Nativity of Mary, Gospel  
 of  
 of Apocryphal Gospels . 195<sup>a</sup> (Hutchison)  
 Natural, Nature . . . . . 2121<sup>b</sup> (W. L. Walker)  
 Natural Features . . . . . 2122<sup>a</sup> (Day)  
 Arabah, the . . . . . 2122<sup>a</sup>  
 of Champaign . . . . . 592<sup>b</sup> (Day)  
 of Country . . . . . 724<sup>a</sup> (Day)  
 of Desert . . . . . 831<sup>b</sup> (Day)  
 Highlands . . . . . 2122<sup>a</sup>  
 of Hill, Hill Country . . 1392<sup>a</sup> (Masterman)  
 of Lowland . . . . . 1934<sup>b</sup> (Day)  
 Negeb . . . . . 2122<sup>b</sup>; 2130<sup>a</sup> (Master-  
 man)  
 of Plain . . . . . 2406<sup>b</sup> (Day)  
 of Pool . . . . . 2419<sup>b</sup> (Day)  
 of South . . . . . 2838<sup>a</sup> (Day)  
 of Syria . . . . . 2881<sup>a</sup> (Christie)  
 Natural History  
 of Birds . . . . . 475<sup>a</sup> (Stratton-Porter)  
 of Botany . . . . . 505<sup>a</sup> (Masterman)  
 of Fish . . . . . 1114<sup>b</sup> (Day)  
 of Insects . . . . . 1473<sup>a</sup> (Day)  
 of Zoology . . . . . 3155<sup>a</sup> (Day)  
 Natural Man, The . . . . . 1974<sup>a</sup> (Webb)  
 Nature (Natural) . . . . . 2121<sup>b</sup> (W. L. Walker)  
 Naught  
 of Nought . . . . . 2156<sup>b</sup> (W. L. Walker)  
 Naught, Naughty,  
 Naughtiness . . . . . 2122<sup>b</sup>  
 Naum (Nahum) . . . . . 2109<sup>b</sup>  
 Nave  
 of Sea, Molten . . . . . 2708<sup>a</sup> (Caldecott)  
 Nave (Nun) . . . . . 2122<sup>b</sup>  
 Navel . . . . . 2122<sup>b</sup> (Luering)  
 Navy  
 of Ships and Boats . . . 2774<sup>a</sup> (Nicol)  
 Nazarene . . . . . 2123<sup>a</sup> (Dosker)  
 Honorable name . . . . . 2123<sup>a</sup>  
 Name of scorn . . . . . 2123<sup>a</sup>  
 Nazareth . . . . . 2123<sup>b</sup> (Ewing)  
 Jesus at . . . . . 2124<sup>a</sup>  
 of Joseph . . . . . 1741<sup>a</sup> (Kerr)

Nazareth—*continued*  
 Later history . . . . . 2124<sup>a</sup>  
 In NT only . . . . . 2123<sup>b</sup>  
 Position and features . 2123<sup>b</sup>  
 Nazirite (Nazarite) . . . 2124<sup>a</sup> (Christie)  
 Antiquity and origin . 2124<sup>b</sup>  
 Conditions of vow . . . 2125<sup>a</sup>  
 In early Christian  
 groups . . . . . 2125<sup>b</sup>  
 Initiation and release . 2125<sup>a</sup>  
 of Rechabites . . . . . 2535<sup>b</sup> (Mack)  
 Samson and Samuel . . 2125<sup>b</sup>  
 of Separate . . . . . 2721<sup>b</sup>  
 of Separation . . . . . 2721<sup>b</sup>  
 of Vow . . . . . 3058<sup>a</sup> (Levertoff)  
 Neah . . . . . 2126<sup>a</sup>  
 Neapolis . . . . . 2126<sup>a</sup> (Tod)  
 of Philippi . . . . . 2369<sup>a</sup> (Tod)  
 of Samothrace . . . . . 2675<sup>a</sup> (Kinsella)  
 Near, Nigh . . . . . 2126<sup>a</sup>  
 Neariah . . . . . 2126<sup>b</sup>  
 Nebai  
 of Nobai . . . . . 2154<sup>a</sup>  
 Nebaioth . . . . . 2126<sup>b</sup> (Fulton)  
 Neballat . . . . . 2126<sup>b</sup>  
 of Zeboim . . . . . 3134<sup>a</sup> (Masterman)  
 Nebat . . . . . 2126<sup>b</sup>  
 of Jeroboam I . . . . . 1593<sup>a</sup> (Mosiman)  
 Nebo (god) . . . . . 2126<sup>b</sup>  
 of Babylonia and As-  
 syria, Religion of . . . 368<sup>b</sup> (Rogers)  
 Nebo (place) . . . . . 2126<sup>b</sup> (Ewing)  
 Nebo, Mount . . . . . 2127<sup>a</sup> (Ewing)  
 of Nooma . . . . . 2155<sup>a</sup>  
 Nebuchadnezzar, Nebu-  
 chadrezzar . . . . . 2127<sup>b</sup> (R. D. Wilson)  
 Buildings of . . . . . 2128<sup>b</sup>  
 And Daniel . . . . . 782<sup>a</sup> (R. D. Wilson)  
 Family and sources . . 2127<sup>b</sup>  
 of Nabuchodonosor . . 2108<sup>a</sup>  
 Name . . . . . 2127<sup>b</sup>  
 of Nebuchadnezzar . . . 349<sup>b</sup> (Clay)  
 Political history . . . . . 2128<sup>a</sup>  
 Traditions regarding . 2128<sup>b</sup>  
 Nebuchadnezzar . . . . . 349<sup>b</sup> (Clay)  
 Nebuchadnezzar I . . . . 366<sup>b</sup> (Clay)  
 Nebuchadnezzar II . . . . 367<sup>b</sup> (Clay)  
 New Babylonian Em-  
 pire under . . . . . 572<sup>b</sup> (Nicol); 367<sup>b</sup> (Clay)  
 Nebusaradan . . . . . 2129<sup>a</sup>  
 Nebushazban (Nebu-  
 shasban) . . . . . 2129<sup>a</sup>  
 Necho, Nechoh  
 of Pharaoh-necoh . . . 2360<sup>a</sup> (Nicol)  
 Neck . . . . . 2129<sup>a</sup> (Luering)  
 of Footstool . . . . . 1126<sup>a</sup> (Doolan)  
 Necklace . . . . . 2129<sup>b</sup>  
 Neco . . . . . 2129<sup>b</sup>  
 of Pharaoh-necoh . . . 2360<sup>a</sup> (Nicol)  
 Necodan  
 of Nekoda . . . . . 2133<sup>a</sup>

- Necromancy  
 of Astrology . . . . . 295<sup>b</sup> (Maunder)  
 of Divination . . . . . 860<sup>a</sup> (T. W. Davies)  
 of Witchcraft . . . . . 3097<sup>a</sup> (T. W. Davies)
- Nedabiah . . . . . 2129<sup>b</sup>
- Needle . . . . . 2129<sup>b</sup> (Patch)  
 of Camel . . . . . 547<sup>b</sup> (Day)
- Needlework  
 of Embroidery . . . . . 940<sup>a</sup> (Patch)
- Needy  
 of Poor . . . . . 2420<sup>a</sup> (W. L. Walker)
- Needing . . . . . 2130<sup>a</sup> (Easton)  
 of Sneeze . . . . . 2819<sup>b</sup>
- Negeb . . . . . 2130<sup>a</sup> (Masterman)  
 of Debir . . . . . 813<sup>b</sup> (Masterman)  
 Description . . . . . 2130<sup>a</sup>  
 of Judaea . . . . . 1757<sup>a</sup> (Masterman)  
 Later history . . . . . 2130<sup>b</sup>  
 Meaning . . . . . 2130<sup>a</sup>  
 of Natural Features . . . . . 2122<sup>a</sup> (Day)  
 OT references . . . . . 2130<sup>b</sup>  
 Prosperity in antiquity . . . . . 2130<sup>b</sup>  
 of Rehoboth . . . . . 2552<sup>a</sup> (Masterman)  
 of Simeon . . . . . 2794<sup>a</sup> (Masterman)  
 of Ziklag . . . . . 3149<sup>a</sup> (Masterman)
- Neginah, Neginoth  
 of Music . . . . . 2094<sup>b</sup> (Millar)  
 of Psalms, Book of . . . . . 2487<sup>a</sup> (Sampey)
- Nehelamite . . . . . 2131<sup>a</sup>
- Nehemiah . . . . . 2131<sup>a</sup> (R. D. Wilson)  
 of Ezra-Nehemiah . . . . . 1083<sup>a</sup> (R. D. Wilson)  
 Family of . . . . . 2131<sup>a</sup>  
 Governor of Judah . . . . . 2131<sup>b</sup>  
 of Israel, History of . . . . . 1526<sup>b</sup> (Orelli)  
 Position at court . . . . . 2131<sup>a</sup>  
 Reforms and labors of . . . . . 575<sup>b</sup> (Nicol)  
 Services to Judah . . . . . 2131<sup>b</sup>
- Nehemiah, Book of  
 of Ezra-Nehemiah . . . . . 1083<sup>a</sup> (R. D. Wilson)
- Nehemias . . . . . 2132<sup>a</sup>
- Nehiloth  
 of Music . . . . . 2094<sup>b</sup> (Millar)
- Nehum . . . . . 2132<sup>a</sup>  
 of Rehum . . . . . 2552<sup>b</sup> (Stearns)  
 of Roimus . . . . . 2597<sup>a</sup>
- Nehushta . . . . . 2132<sup>a</sup>
- Nehushtan . . . . . 2132<sup>a</sup> (Longacre)  
 Hezekiah's destruction  
 of . . . . . 2132<sup>a</sup>  
 of Images . . . . . 1453<sup>a</sup> (Cobern)  
 Sacred serpent, the . . . . . 2132<sup>b</sup>  
 of Serpent, Fiery . . . . . 2737<sup>a</sup> (Day)  
 of Serpent Worship . . . . . 2738<sup>b</sup> (Orr)
- Neiel . . . . . 2132<sup>b</sup>
- Neigh . . . . . 2132<sup>b</sup>
- Neighbor . . . . . 2132<sup>b</sup> (Edwards)
- Nekeb . . . . . 2133<sup>a</sup>
- Nekoda . . . . . 2133<sup>a</sup>  
 of Nekodan . . . . . 2133<sup>a</sup>  
 of Noeba . . . . . 2154<sup>b</sup>
- Nekodan . . . . . 2133<sup>a</sup>  
 of Nekoda . . . . . 2133<sup>a</sup>  
 of Noeba . . . . . 2154<sup>b</sup>
- Nemuel . . . . . 2133<sup>b</sup>
- Nemuelites  
 of Nemuel . . . . . 2133<sup>b</sup>
- Nephea  
 of Music . . . . . 2094<sup>b</sup> (Millar)
- Nepheg . . . . . 2133<sup>b</sup>
- Nephew  
 of Relationships, Family . . . . . 2554<sup>a</sup> (N. and E. D. Isaacs)
- Nephi (Nephtar) . . . . . 2133<sup>b</sup> (Angus)
- Nephilim . . . . . 2133<sup>b</sup> (Orr)  
 of Sons of God . . . . . 2835<sup>a</sup> (Crichton)
- Nephis  
 of Niphis . . . . . 2153<sup>a</sup>
- Nephis, Nephisim, Nephishesim, Nephusim . . . . . 2133<sup>b</sup>  
 of Naphish . . . . . 2118<sup>a</sup>  
 of Nephushesim . . . . . 2134<sup>a</sup>
- Nephisim  
 of Nephushesim . . . . . 2134<sup>a</sup>
- Nephtai  
 of Nephtar . . . . . 2133<sup>b</sup> (Angus)
- Nephtalim . . . . . 2133<sup>b</sup>  
 of Naphtali . . . . . 2118<sup>b</sup> (Ewing)
- Nephtar (Naphthar) . . . . . 2133<sup>b</sup> (Angus)
- Nephtoah . . . . . 2134<sup>a</sup> (Masterman)  
 of Eleph . . . . . 927<sup>b</sup>  
 of Etam . . . . . 1010<sup>a</sup> (Masterman)  
 of Netophah . . . . . 2140<sup>a</sup> (Masterman)
- Nephushesim . . . . . 2134<sup>a</sup>  
 of Naphish . . . . . 2118<sup>a</sup>  
 of Nephis, Nephisim . . . . . 2133<sup>b</sup>
- Ner . . . . . 2134<sup>a</sup>
- Nereus . . . . . 2134<sup>b</sup>
- Nergal . . . . . 2134<sup>b</sup>  
 of Babylonia and Assyria, Religion of . . . . . 371<sup>b</sup> (Rogers)  
 of Gods . . . . . 1271<sup>a</sup> (Reeve)
- Nergal-sharezer . . . . . 2134<sup>b</sup>  
 of Rab-mag . . . . . 2522<sup>a</sup> (Clippinger)
- Neri . . . . . 2134<sup>b</sup>  
 of Neriah . . . . . 2134<sup>b</sup>
- Neriah . . . . . 2134<sup>b</sup>  
 of Neri . . . . . 2134<sup>b</sup>
- Nerias . . . . . 2134<sup>b</sup>
- Nero . . . . . 2134<sup>b</sup> (Angus)  
 Ambition of Agrippina . . . . . 2135<sup>a</sup>  
 Downfall and character . . . . . 2137<sup>b</sup>  
 Five golden years . . . . . 2135<sup>b</sup>  
 Great fire, the . . . . . 2136<sup>a</sup>  
 Last years and death . . . . . 2137<sup>a</sup>  
 Name, parentage and training . . . . . 2134<sup>b</sup>  
 Nero and Christianity . . . . . 2138<sup>a</sup>  
 "Nero Redivivus" . . . . . 2137<sup>b</sup>  
 of Number . . . . . 2162<sup>b</sup> (Smith)  
 Paul and Nero . . . . . 2138<sup>a</sup>  
 Persecution of Christians . . . . . 2136<sup>b</sup>  
 of Persecution . . . . . 2325<sup>a</sup> (Rutherford)

Nero—*continued*

- Poppaea's influence . . . 2135<sup>b</sup>  
 cf Puteoli . . . . . 2511<sup>a</sup> (Allen)  
 References in Revelation . . . . . 2137<sup>b</sup>  
 cf Roman Empire and Christianity . . . . . 2605<sup>b</sup> (Angus)  
 Tigellinus . . . . . 2136<sup>a</sup>  
 Nest . . . . . 2138<sup>b</sup> (Stratton-Porter)  
 cf Owl . . . . . 2205<sup>b</sup> (Stratton-Porter)  
 Net  
 cf Fishing . . . . . 1116<sup>a</sup> (Patch)  
 cf Fowler . . . . . 1143<sup>a</sup> (Stratton-Porter)  
 cf Snare . . . . . 2819<sup>a</sup> (Stratton-Porter)  
 cf Trap . . . . . 3007<sup>a</sup> (Stratton-Porter)  
 Netaim . . . . . 2139<sup>a</sup>  
 Nethanel . . . . . 2139<sup>a</sup> (Lees)  
 Nethaniah . . . . . 2139<sup>a</sup>  
 Nethinim . . . . . 2139<sup>b</sup> (Lees)  
 History of . . . . . 2139<sup>b</sup>  
 cf Keros . . . . . 1793<sup>b</sup>  
 Meaning . . . . . 2139<sup>b</sup>  
 cf Padon . . . . . 2207<sup>a</sup>  
 Post-exilic references . . . . . 2139<sup>b</sup>  
 cf Priests and Levites . . . . . 2446<sup>b</sup> (Wiener)  
 cf Solomon . . . . . 2824<sup>a</sup> (Weir)  
 cf Solomon's Servants . . . . . 2825<sup>b</sup> (Mack)  
 cf Temple Keepers (Servants) . . . . . 2942<sup>b</sup> (Easton)  
 Netophah . . . . . 2140<sup>a</sup> (Masterman)  
 cf Nephtoah . . . . . 2134<sup>a</sup> (Masterman)  
 Netophas (Netophah) . . . . . 2140<sup>a</sup>  
 Netophathi, Netophathites  
 cf Netophah . . . . . 2140<sup>a</sup> (Masterman)  
 Nettles . . . . . 2140<sup>a</sup> (Masterman)  
 cf Thorns, Thistles . . . . . 2974<sup>a</sup> (Masterman)  
 Network . . . . . 2140<sup>a</sup>  
 cf Jachin and Boaz . . . . . 1547<sup>b</sup> (Caldecott)  
 New, Newness . . . . . 2140<sup>b</sup> (W. L. Walker)  
 New Birth  
 cf Regeneration . . . . . 2546<sup>b</sup> (Nuelsen)  
 New Commandment  
 cf Brotherly Love . . . . . 525<sup>b</sup> (Rees)  
 New Covenant . . . . . 731<sup>a</sup> (M'Caig)  
 cf Law in NT . . . . . 1851<sup>a</sup> (M'Caig)  
 New Earth  
 cf Eschatology of NT . . . . . 979<sup>b</sup> (Vos)  
 cf Heavens, New . . . . . 1353<sup>a</sup> (Vos)  
 New Heavens . . . . . 1353<sup>a</sup> (Vos)  
 New Jerusalem . . . . . 1621<sup>b</sup> (Vos)  
 cf Revelation of John . . . . . 2582<sup>b</sup> (Orr)  
 New Man . . . . . 1975<sup>a</sup> (Webb)  
 New Moon  
 cf Feasts and Fasts . . . . . 1103<sup>a</sup> (E. D. Isaacs);  
 2081<sup>a</sup> (Schenk)  
 New Testament  
 cf Archaeology and Criticism . . . . . 226<sup>a</sup> (Kyle)  
 cf Bible . . . . . 459<sup>b</sup> (Orr)  
 cf Canon of NT . . . . . 563<sup>a</sup> (Riggs)  
 cf Inspiration of . . . . . 1483<sup>a</sup> (Warfield)  
 New Testament Canon . . . . . 563<sup>a</sup> (Riggs)  
 New Testament Language . . . . . 1826<sup>b</sup> (A. T. Robertson)  
 New Testament Text . . . . . 2950<sup>b</sup> (Sitterly)  
 New Year  
 cf Time . . . . . 2981<sup>b</sup> (Porter)  
 cf Year . . . . . 3126<sup>a</sup>  
 Nezhiah . . . . . 2141<sup>a</sup>  
 Nezhib . . . . . 2141<sup>a</sup>  
 Nibhaz . . . . . 2141<sup>a</sup>  
 cf Gods . . . . . 1271<sup>a</sup> (Reeve)  
 Nibshan . . . . . 2141<sup>a</sup>  
 Nicanor . . . . . 2141<sup>a</sup> (Angus)  
 Nicene Creed . . . . . 742<sup>b</sup> (Alexander)  
 Nicodemus . . . . . 2141<sup>b</sup> (Kerr)  
 Interview with Jesus . . . . . 2142<sup>a</sup>  
 cf Jesus Christ . . . . . 1637<sup>b</sup> (Orr)  
 Later references . . . . . 2142<sup>a</sup>  
 Nicodemus, Apocryphal  
 Gospel of . . . . . 200<sup>a</sup> (Hutchison)  
 Nicolaitans . . . . . 2142<sup>b</sup> (Kerr)  
 Controversies over . . . . . 2142<sup>b</sup>  
 cf Nicolaus . . . . . 2143<sup>a</sup> (S. F. Hunter)  
 References to . . . . . 2142<sup>b</sup>  
 Sect of . . . . . 2142<sup>b</sup>  
 Nicolaus, Nicolas . . . . . 2143<sup>a</sup> (S. F. Hunter)  
 cf Nicolaitans . . . . . 2142<sup>b</sup> (Kerr)  
 Nicopolis . . . . . 2143<sup>a</sup> (Harry)  
 Niger  
 cf Simeon . . . . . 2794<sup>a</sup> (S. F. Hunter)  
 Nigh  
 cf Near . . . . . 2126<sup>a</sup>  
 Night . . . . . 2143<sup>b</sup> (Dosker)  
 cf Day and Night . . . . . 798<sup>a</sup> (Wolf)  
 Night-hawk . . . . . 2143<sup>b</sup> (Stratton-Porter)  
 cf Hawk . . . . . 1345<sup>a</sup> (Stratton-Porter)  
 Night-monster . . . . . 2143<sup>b</sup> (Sweet)  
 Accepted translation . . . . . 2144<sup>a</sup>  
 cf Communion with Demons . . . . . 689<sup>b</sup> (Sweet)  
 cf Demonology . . . . . 827<sup>b</sup> (Sweet)  
 Folklore in OT . . . . . 2144<sup>a</sup>  
 cf Lunatic . . . . . 1941<sup>b</sup> (Sweet)  
 Poetical passages . . . . . 2144<sup>b</sup>  
 Term *lilith* . . . . . 2145<sup>a</sup>  
 Night-watch . . . . . 2145<sup>a</sup>  
 cf Time . . . . . 2981<sup>b</sup> (Porter)  
 cf Watch . . . . . 3074<sup>a</sup> (Porter)  
 Nile . . . . . 2145<sup>a</sup> (Kyle); 907<sup>a</sup> (Petrie)  
 In history . . . . . 2146<sup>b</sup>  
 Inundation of . . . . . 2146<sup>a</sup>  
 Irrigation and farming . . . . . 2147<sup>a</sup>  
 Location of temples and cemeteries . . . . . 2146<sup>b</sup>  
 Name . . . . . 2145<sup>b</sup>  
 Physical geography . . . . . 2145<sup>b</sup>  
 Relation to religion . . . . . 2147<sup>a</sup>  
 cf Shihor . . . . . 2768<sup>a</sup> (Kyle)  
 Value to Egypt . . . . . 2146<sup>a</sup>  
 Nimrah . . . . . 2147<sup>a</sup> (Ewing)  
 cf Leopard . . . . . 1866<sup>b</sup> (Day)  
 cf Nimrim . . . . . 2147<sup>a</sup> (Ewing)

- Nimrim . . . . . 2147<sup>a</sup> (Ewing)  
 cf Leopard . . . . . 1866<sup>b</sup> (Day)  
 cf Nimrah . . . . . 2147<sup>a</sup> (Ewing)  
 Nimrod . . . . . 2147<sup>b</sup> (Mack)  
 cf Astronomy . . . . . 300<sup>b</sup> (Maunder)  
 cf Babylonia and Assyria, Religion of . . . 368<sup>b</sup> (Rogers)  
 As hunter . . . . . 1440<sup>b</sup>  
 cf Merodach . . . . . 2036<sup>b</sup>  
 cf Nineveh . . . . . 2148<sup>a</sup> (Pinches)  
 cf Orion . . . . . 2201<sup>b</sup>  
 Nimshi . . . . . 2147<sup>b</sup>  
 Nineveh . . . . . 2147<sup>b</sup> (Pinches)  
 Defenses . . . . . 2148<sup>a</sup>  
 Downfall of . . . . . 572<sup>a</sup> (Nicol)  
 Extent and population 2148<sup>b</sup>  
 Illustrations in bas-relief . . . . . 2150<sup>b</sup>  
 cf Nahum, Book of . . . 2110<sup>b</sup> (Eiselen)  
 Name . . . . . 2148<sup>a</sup>  
 cf Nimrod . . . . . 2147<sup>b</sup> (Mack)  
 Overthrow of . . . . . 2150<sup>b</sup>  
 Palace of Assur-bani-apli . . . . . 2149<sup>b</sup>  
 Palace of Sennacherib . 2149<sup>a</sup>  
 Palaces of . . . . . 2149<sup>a</sup>  
 cf Rehoboth-ir . . . . . 2552<sup>b</sup> (Pinches)  
 cf Resen . . . . . 2561<sup>a</sup> (Pinches)  
 Ruins of . . . . . 2148<sup>b</sup>  
 Sennacherib's description of . . . . . 2149<sup>b</sup>  
 Nineveh, Library of . . . 2151<sup>a</sup> (Sayce)  
 Contents of . . . . . 2152<sup>a</sup>  
 Discovery . . . . . 2151<sup>a</sup>  
 cf Hammurabi, Code of 1327<sup>a</sup> (Ungnad)  
 Historical texts . . . . . 2152<sup>b</sup>  
 cf Libraries . . . . . 1886<sup>b</sup> (Richardson)  
 Religious and other texts . . . . . 2152<sup>a</sup>  
 Translations and exercises . . . . . 2152<sup>a</sup>  
 Writing materials . . . 2151<sup>b</sup>  
 Ninevites . . . . . 2153<sup>a</sup>  
 Ninib . . . . . 372<sup>a</sup> (Rogers)  
 Niphis . . . . . 2153<sup>a</sup>  
 Nippur . . . . . 365<sup>a</sup> (Clay)  
 cf Shinar . . . . . 2772<sup>b</sup> (Pinches)  
 Nisan . . . . . 2153<sup>a</sup>  
 cf Calendar . . . . . 541<sup>b</sup> (Porter)  
 Nisroch . . . . . 2153<sup>a</sup>  
 cf Babylonia and Assyria, Religion of . . . 368<sup>b</sup> (Rogers)  
 Nitocris . . . . . 350<sup>b</sup> (Pinches)  
 Nitre . . . . . 2153<sup>a</sup> (Patch)  
 cf Vinegar . . . . . 3051<sup>a</sup> (Easton)  
 No  
 cf No-amon . . . . . 2153<sup>b</sup> (Kyle)  
 Noadiah . . . . . 2153<sup>a</sup>  
 cf Moeth . . . . . 2073<sup>b</sup>  
 cf Neariah . . . . . 2126<sup>b</sup>  
 Noah . . . . . 2153<sup>a</sup> (Wright); 139<sup>a</sup>  
 (Davis)  
 Noah—*continued*  
 cf Antediluvian Patriarchs . . . . . 139<sup>a</sup> (Davis)  
 cf Ark of . . . . . 246<sup>a</sup> (Wright)  
 cf Deluge of Noah . . . 821<sup>b</sup> (Wright)  
 cf Family of, in Genesis 1206<sup>b</sup> (Möller)  
 cf Noe . . . . . 2154<sup>b</sup>  
 Noah (woman) . . . . . 2153<sup>b</sup>  
 Noah, Book of  
 cf Apocalyptic Literature . . . . . 161<sup>b</sup> (J. E. H. Thomson)  
 No-amon . . . . . 2153<sup>b</sup> (Kyle)  
 Nob . . . . . 2153<sup>b</sup> (Ewing)  
 Nobah . . . . . 2154<sup>a</sup> (Ewing)  
 cf Nophah . . . . . 2155<sup>a</sup>  
 Nobai . . . . . 2154<sup>a</sup>  
 Noble, Nobles, Nobleman . . . . . 2154<sup>a</sup> (W. L. Walker)  
 Nod . . . . . 2154<sup>b</sup>  
 Nodab . . . . . 2154<sup>b</sup>  
 Noe . . . . . 2154<sup>b</sup>  
 cf Noah . . . . . 2153<sup>a</sup> (Wright)  
 Noeba . . . . . 2154<sup>b</sup>  
 cf Nekoda . . . . . 2133<sup>a</sup>  
 cf Nekodan . . . . . 2133<sup>a</sup>  
 Nogah . . . . . 2154<sup>b</sup>  
 cf Naggai . . . . . 2108<sup>b</sup>  
 Nohah . . . . . 2154<sup>b</sup>  
 Noise . . . . . 2154<sup>b</sup> (W. L. Walker)  
 Noisome . . . . . 2155<sup>a</sup> (W. L. Walker)  
 Non . . . . . 2155<sup>a</sup>  
 cf Nun . . . . . 2170<sup>a</sup>  
 Nooma . . . . . 2155<sup>a</sup>  
 cf Nebo . . . . . 2126<sup>b</sup>  
 Noon, Noonday . . . . . 2155<sup>a</sup>  
 cf Day and Night . . . 798<sup>a</sup> (Wolf)  
 cf Midday . . . . . 2049<sup>a</sup>  
 cf Time . . . . . 2981<sup>b</sup> (Porter)  
 Noph . . . . . 2155<sup>a</sup>  
 cf Memphis . . . . . 2030<sup>b</sup> (Petrie)  
 Nophah . . . . . 2155<sup>a</sup>  
 cf Nobah . . . . . 2154<sup>a</sup> (Ewing)  
 North, North Country . 2155<sup>a</sup> (Day)  
 cf Astronomy . . . . . 300<sup>b</sup> (Maunder)  
 Northeast, Southeast . . 2155<sup>b</sup> (Day)  
 cf Phoenix . . . . . 2391<sup>a</sup> (Calder)  
 Northern Israel  
 cf Joahaz . . . . . 1678<sup>b</sup>  
 Nose, Nostrils . . . . . 2155<sup>b</sup> (Luering)  
 cf Branch . . . . . 513<sup>b</sup> (Masterman)  
 Nose-jewels . . . . . 2156<sup>a</sup> (Pollard)  
 cf Amulet . . . . . 126<sup>b</sup> (T. W. Davies)  
 cf Jewel . . . . . 1675<sup>b</sup> (Orr)  
 Nostrils (Nose) . . . . . 2155<sup>b</sup> (Luering)  
 Notable . . . . . 2156<sup>a</sup> (W. L. Walker)  
 Note . . . . . 2156<sup>b</sup> (W. L. Walker)  
 Nothing . . . . . 2156<sup>b</sup> (W. L. Walker)  
 Nought . . . . . 2156<sup>b</sup> (W. L. Walker)  
 Nourish . . . . . 2157<sup>a</sup> (Berry)  
 Novice . . . . . 2157<sup>a</sup> (Rutherford)  
 Number . . . . . 2157<sup>a</sup> (Smith)  
 Arithmetic . . . . . 2157<sup>b</sup>

- Number—*continued*  
 Exaggerated numbers .2158<sup>a</sup>  
 Forty, the number . . . . .2158<sup>b</sup>  
 Four, the number . . . . .2161<sup>b</sup>  
 Gematria . . . . .2162<sup>b</sup>  
 of Nero . . . . .2138<sup>a</sup> (Angus)  
 Notation of numbers . . . . .2157<sup>b</sup>  
 Notation by words,  
 signs and letters . . . . .2157<sup>b</sup>  
 In OT . . . . .2158<sup>a</sup>  
 of Pentateuch . . . . .2302<sup>b</sup>; 2309<sup>b</sup> (Wiener)  
 Round numbers . . . . .2158<sup>b</sup>  
 of Sabbath . . . . .2629<sup>b</sup> (Sampey)  
 Seven, the number . . . . .2159<sup>b</sup>  
 Apocalyptic use of . . . . .2160<sup>b</sup>  
 Historical use of . . . . .2160<sup>a</sup>  
 Literary use of . . . . .2160<sup>a</sup>  
 Multiples of . . . . .2160<sup>b</sup>  
 Ritual use of . . . . .2160<sup>a</sup>  
 Significant numbers . . . . .2159<sup>b</sup>  
 Ten, the number . . . . .2162<sup>a</sup>  
 Three, the number . . . . .2161<sup>a</sup>  
 Twelve, the number . . . . .2162<sup>a</sup>  
 Number, Golden . . . . .1275<sup>b</sup>  
 Numbering  
 of David . . . . .790<sup>b</sup> (Weir)  
 of Quirinius . . . . .645<sup>a</sup> (Armstrong)  
 Numbers  
 of Gad, Son of Jacob . . . . .1151<sup>a</sup>  
 of Issachar . . . . .1541<sup>b</sup> (Ewing)  
 of Judah . . . . .1758<sup>a</sup> (Ewing)  
 of Naphtali . . . . .2118<sup>b</sup> (Ewing)  
 of Reuben . . . . .2572<sup>b</sup> (Ewing)  
 of Zebulun . . . . .3135<sup>a</sup> (Ewing)  
 Numbers, Book of . . . . .2163<sup>a</sup> (Whitelaw)  
 Authorship . . . . .2168<sup>b</sup>  
 Against Mosaic view 2168<sup>b</sup>  
 Arguments for Mo-  
 saic tradition . . . . .2169<sup>a</sup>  
 Historical credibility . . . . .2165<sup>b</sup>  
 Chronological errors 2165<sup>b</sup>  
 Physical impossibil-  
 ities . . . . .2167<sup>b</sup>  
 Statistical errors . . . . .2166<sup>a</sup>  
 Literary structure . . . . .2163<sup>b</sup>  
 Grounds of analysis 2163<sup>b</sup>  
 Objections to analy-  
 sis . . . . .2164<sup>a</sup>  
 Title and contents . . . . .2163<sup>a</sup>  
 of Wanderings of Israel 3065<sup>b</sup>; 3069<sup>a</sup> (Conder)  
 Numenius . . . . .2170<sup>a</sup> (Angus)  
 of Lucius . . . . .1934<sup>b</sup> (Hutchison); 1935<sup>a</sup>  
 (S. F. Hunter)  
 Numeri, Roman . . . . .257<sup>b</sup> (Allen)  
 Nun . . . . .2170<sup>a</sup>  
 Nûn . . . . .2170<sup>a</sup>  
 of Alphabet . . . . .103<sup>b</sup> (Richardson)  
 Nurse, Nursing . . . . .2170<sup>a</sup> (T. Lewis)  
 Nurture . . . . .2170<sup>b</sup>  
 Nuts . . . . .2170<sup>b</sup> (Masterman); 1123<sup>a</sup>  
 (Eager)  
 Nymphas . . . . .2170<sup>b</sup> (Rutherford)  
 Oabdius . . . . .2171<sup>a</sup>  
 Oak . . . . .2171<sup>a</sup> (Masterman)  
 Hebrew words and ref-  
 erences . . . . .2171<sup>u</sup>  
 Oaks in modern Pales-  
 tine . . . . .2172<sup>a</sup>  
 of Terebinth . . . . .2949<sup>a</sup> (Masterman)  
 Varieties . . . . .2171<sup>b</sup>  
 Oak of Tabor . . . . .2172<sup>b</sup>  
 Oar  
 of Ships and Boats . . . . .2774<sup>a</sup> (Nicol)  
 Oath . . . . .2172<sup>b</sup> (Levertoff)  
 of Adjuration . . . . .56<sup>a</sup> (Pratt)  
 Forms of swearing . . . . .2172<sup>b</sup>  
 Formula of oath . . . . .2173<sup>a</sup>  
 of Judge . . . . .1771<sup>b</sup> (Levertoff)  
 of Law in NT . . . . .1845<sup>a</sup> (M'Caig)  
 Law regarding oaths . . . . .2172<sup>b</sup>  
 of Vow . . . . .3058<sup>a</sup> (Levertoff)  
 Obadiah (general) . . . . .2173<sup>a</sup> (Sampey)  
 of Abdias . . . . .4<sup>a</sup>  
 Obadiah, Book of . . . . .2173<sup>a</sup> (Sampey)  
 Capture of Jerusalem 2174<sup>a</sup>  
 Contents . . . . .2173<sup>b</sup>  
 Date . . . . .2173<sup>b</sup>  
 Relation to Jeremiah  
 and Joel . . . . .2173<sup>b</sup>  
 Style and allusions . . . . .2174<sup>b</sup>  
 Unity . . . . .2173<sup>b</sup>  
 Obal  
 of Ebal . . . . .889<sup>b</sup>  
 Obdia, Habaiah, Ho-  
 baiah . . . . .2174<sup>b</sup>  
 Obed . . . . .2175<sup>a</sup> (Roberts)  
 Obed-edom . . . . .2175<sup>a</sup> (Roberts)  
 Obedience, Obey . . . . .2175<sup>a</sup> (Clippinger)  
 of Disobedience . . . . .854<sup>b</sup> (Clippinger)  
 Meaning of terms . . . . .2175<sup>a</sup>  
 NT conception . . . . .2175<sup>b</sup>  
 OT conception . . . . .2175<sup>b</sup>  
 Obedience of Christ . . . . .2175<sup>b</sup> (Crannell)  
 of Atonement . . . . .321<sup>a</sup> (Carver)  
 Christological bearing 2176<sup>a</sup>  
 An element in char-  
 acter . . . . .2175<sup>b</sup>  
 Soteriological bear-  
 ing . . . . .2176<sup>b</sup>  
 Obeisance . . . . .2177<sup>a</sup> (T. Lewis)  
 Obelisk . . . . .2177<sup>b</sup>  
 of Pillar . . . . .2398<sup>b</sup> (Orr)  
 Obeth . . . . .2177<sup>b</sup>  
 Obey (Obedience) . . . . .2175<sup>a</sup> (Clippinger)  
 Obil . . . . .2177<sup>b</sup>  
 Object . . . . .2177<sup>b</sup>  
 Oblation . . . . .2177<sup>b</sup>  
 Obodas . . . . .240<sup>a</sup> (Dosker)  
 Oboth . . . . .2177<sup>b</sup>  
 of Wanderings of Is-  
 rael . . . . .3064<sup>a</sup> (Conder)  
 Obscurity . . . . .2177<sup>b</sup>  
 Observation . . . . .2178<sup>a</sup> (Easton)  
 Observe . . . . .2177<sup>b</sup> (Easton)

- Observer of Times  
 cf Divination . . . . . 860<sup>a</sup> (T. W. Davies)
- Obstinacy  
 cf Harden . . . . . 1338<sup>a</sup> (W. L. Walker)
- Occasion . . . . . 2178<sup>a</sup>
- Occupy . . . . . 2178<sup>a</sup> (Estes)  
 cf Trade . . . . . 3002<sup>a</sup> (Easton)
- Occurrent . . . . . 2178<sup>a</sup>
- Ochielus . . . . . 2178<sup>a</sup>
- Ochan . . . . . 2178<sup>a</sup>  
 cf Achan . . . . . 35<sup>b</sup> (Beecher)
- Ochre, Red . . . . . 2178<sup>a</sup>  
 cf Pencil . . . . . 2298<sup>a</sup>
- Ocidelus . . . . . 2178<sup>b</sup>
- Ocina . . . . . 2178<sup>b</sup>
- Ocodelus (Ocidelus) . . . . . 2178<sup>b</sup>
- Ocran  
 cf Ochran . . . . . 2178<sup>a</sup>
- Oded . . . . . 2178<sup>b</sup> (Roberts)  
 cf Addo (Iddo) . . . . . 1447<sup>b</sup> (Crannell)  
 cf Azariah . . . . . 342<sup>a</sup> (W. W. Davies)
- Odes of Solomon  
 cf Apocalyptic Literature . . . . . 161<sup>b</sup> (J. E. H. Thomson)
- Odollam . . . . . 2178<sup>b</sup>  
 cf Adullam . . . . . 62<sup>b</sup> (Beecher)
- Odomarra (Odamera) . . . . . 2178<sup>b</sup>
- Odamera . . . . . 2178<sup>b</sup>
- Odonarkes (Odamera) . . . . . 2178<sup>b</sup>
- Odor . . . . . 2178<sup>b</sup>  
 cf Savor . . . . . 2700<sup>b</sup> (Edwards)
- Of . . . . . 2179<sup>a</sup> (Easton)
- Offence, Offend . . . . . 2179<sup>b</sup> (W. L. Walker)  
 NT usage . . . . . 2180<sup>a</sup>  
 OT usage . . . . . 2179<sup>b</sup>  
 cf Stumbling-block,  
 Stumbling-stone . . . . . 2867<sup>b</sup> (Hovey)
- Offer, Offering  
 cf Sacrifice, OT . . . . . 2638<sup>a</sup> (Reeve)
- Office . . . . . 2180<sup>a</sup> (T. Lewis)
- Officer . . . . . 2180<sup>b</sup> (T. Lewis)
- Offices of Christ . . . . . 616<sup>b</sup> (Bevan)
- Offscouring . . . . . 2180<sup>b</sup> (Gerberding)
- Offspring  
 cf Children . . . . . 606<sup>b</sup> (Stearns)
- Often . . . . . 2180<sup>b</sup>
- Og . . . . . 2180<sup>b</sup> (Orr)  
 cf Argob . . . . . 240<sup>b</sup> (Ewing)  
 cf Bashan . . . . . 411<sup>a</sup> (Ewing)  
 cf Rephaim . . . . . 2559<sup>b</sup> (Porter)
- Ohad . . . . . 2181<sup>a</sup>
- Ohel . . . . . 2181<sup>a</sup>
- Oholah . . . . . 2181<sup>a</sup>  
 cf Oholibah . . . . . 2181<sup>a</sup> (W. W. Davies)
- Oholiab . . . . . 2181<sup>a</sup>
- Oholibah . . . . . 2181<sup>a</sup> (W. W. Davies)
- Oholibamah . . . . . 2181<sup>a</sup>
- Oil . . . . . 2181<sup>b</sup> (Patch)  
 Figurative references . . . . . 2182<sup>b</sup>  
 cf Food . . . . . 1121<sup>b</sup> (Eager)  
 cf Lamp . . . . . 1825<sup>a</sup> (Porter)  
 cf Meal . . . . . 2013<sup>b</sup>
- Oil—*continued*  
 cf Meals, Meal-time . . . . . 2014<sup>a</sup> (Eager)  
 cf Oil, Anointing . . . . . 2183<sup>a</sup> (Orr)  
 cf Ointment . . . . . 2183<sup>a</sup> (Patch)  
 cf Perfume . . . . . 2321<sup>b</sup> (Patch)  
 Production . . . . . 2181<sup>b</sup>  
 Terms used for . . . . . 2181<sup>b</sup>  
 Uses of . . . . . 2182<sup>a</sup>  
 cf Wine, Wine Press . . . . . 3086<sup>a</sup> (Easton)
- Oil, Anointing . . . . . 2183<sup>a</sup> (Orr)  
 cf Anointing . . . . . 138<sup>a</sup> (Eager)  
 cf Oil . . . . . 2181<sup>b</sup> (Patch)
- Oil, Beaten . . . . . 2183<sup>a</sup>  
 cf Candlestick, Golden 553<sup>a</sup> (Orr)  
 cf Oil . . . . . 2181<sup>b</sup> (Patch)
- Oil, Holy  
 cf Anointing . . . . . 138<sup>a</sup> (Eager)  
 cf Oil . . . . . 2181<sup>b</sup> (Patch)
- Oil-making  
 cf Crafts . . . . . 734<sup>a</sup> (Patch)
- Oil, Olive  
 cf Oil . . . . . 2181<sup>b</sup> (Patch)  
 cf Olive Tree . . . . . 2184<sup>a</sup> (Masterman)
- Oil Press  
 cf Oil . . . . . 2181<sup>b</sup> (Patch)  
 cf Wine, Wine Press . . . . . 3086<sup>a</sup> (Easton)
- Oil Tree . . . . . 2183<sup>a</sup> (Masterman); 508<sup>a</sup>  
 (Masterman)  
 cf Olive Tree . . . . . 2184<sup>a</sup> (Masterman)  
 cf Pine Tree . . . . . 2399<sup>a</sup> (Masterman)
- Ointment . . . . . 2183<sup>a</sup> (Patch)  
 cf Anointing . . . . . 138<sup>a</sup> (Eager)  
 cf Oil . . . . . 2181<sup>b</sup> (Patch)  
 cf Perfume . . . . . 2321<sup>b</sup> (Patch)
- Olamus . . . . . 2183<sup>b</sup>
- Old  
 cf Age, Old Age . . . . . 71<sup>a</sup> (W. L. Walker)
- Old Gate  
 cf Jerusalem . . . . . 1607<sup>a</sup> (Masterman)
- Old Man . . . . . 2183<sup>b</sup> (Pratt)  
 cf Man, Natural . . . . . 1974<sup>a</sup> (Webb)  
 cf Man, New . . . . . 1975<sup>a</sup> (Webb)
- Old Prophet, The . . . . . 2183<sup>b</sup> (Roberts)  
 Central truths . . . . . 2184<sup>a</sup>  
 Critical considerations . . . . . 2183<sup>b</sup>  
 Narrative in 1 K 13 . . . . . 2183<sup>b</sup>
- Old Testament, Text of . . . . . 2957<sup>b</sup> (Weir)  
 Criticism of . . . . . 748<sup>b</sup> (Orr)  
 Inspiration of . . . . . 1482<sup>a</sup> (Warfield)
- Old Testament Canon . . . . . 554<sup>a</sup> (Robinson)
- Old Testament Lan-  
 guages . . . . . 1832<sup>a</sup> (Weir)
- Oleaster  
 cf Oil Tree . . . . . 2183<sup>a</sup> (Masterman)
- Olive  
 cf Food . . . . . 1122<sup>b</sup> (Eager)  
 cf Oil . . . . . 2181<sup>b</sup> (Patch)  
 cf Olive Tree . . . . . 2184<sup>a</sup> (Masterman)
- Olive Berries  
 cf Olive Tree . . . . . 2184<sup>a</sup> (Masterman)
- Olive, Grafted  
 cf Olive Tree . . . . . 2184<sup>a</sup> (Masterman)

- Olive Tree . . . . . 2184<sup>a</sup> (Masterman)  
 Fruit . . . . . 2185<sup>a</sup>  
 Importance . . . . . 2184<sup>b</sup>  
 cf Oil Tree . . . . . 2183<sup>a</sup> (Masterman)  
 Olive oil . . . . . 2185<sup>b</sup>  
 Wild olives . . . . . 2185<sup>b</sup>
- Olive, Wild . . . . . 2185<sup>b</sup>
- Olive Yard  
 cf Olive Tree . . . . . 2184<sup>b</sup> (Masterman)
- Olives, Mount of . . . . . 2185<sup>b</sup> (Masterman)  
 cf Bahurim . . . . . 378<sup>a</sup> (Ewing)  
 cf Bethphage . . . . . 451<sup>a</sup> (Masterman)  
 Churches and tradi-  
 tions . . . . . 2188<sup>a</sup>  
 cf Gethsemane . . . . . 1221<sup>b</sup> (Masterman)  
 High places . . . . . 2187<sup>a</sup>  
 cf Jerusalem . . . . . 1598<sup>b</sup> (Masterman)  
 Names . . . . . 2186<sup>a</sup>  
 Olivet and Jesus . . . . . 2187<sup>a</sup>  
 OT associations . . . . . 2186<sup>b</sup>  
 Situation and extent . . . . . 2186<sup>a</sup>  
 View of Jerusalem from 2187<sup>b</sup>
- Olivet  
 cf Olives, Mount of . . . . . 2185<sup>b</sup> (Masterman)
- Olympas . . . . . 2188<sup>b</sup>
- Olympius . . . . . 2188<sup>b</sup>  
 cf Jupiter . . . . . 1781<sup>a</sup> (Easton)
- Omaerus . . . . . 2188<sup>b</sup>
- Omar . . . . . 2188<sup>b</sup>
- Omega  
 cf Alpha and Omega . . . . . 103<sup>b</sup> (Harry)
- Omens  
 cf Augury . . . . . 331<sup>a</sup> (T. W. Davies)  
 cf Divination . . . . . 860<sup>a</sup> (T. W. Davies)
- Omer . . . . . 2188<sup>b</sup>  
 cf Weights and Meas-  
 ures . . . . . 3079<sup>a</sup> (Porter)
- Omnipotence . . . . . 2188<sup>b</sup> (Vos)  
 Divine powers . . . . . 2189<sup>a</sup>  
 cf God . . . . . 1250<sup>a</sup> (Rees)  
 cf God, Names of . . . . . 1264<sup>b</sup> (Mack)  
 Inherent in Divine  
 names . . . . . 2188<sup>b</sup>  
 Manifestation of . . . . . 2189<sup>b</sup>  
 Modes of expression . . . . . 2189<sup>a</sup>  
 cf Power . . . . . 2427<sup>b</sup> (Orr)  
 Significance of . . . . . 2189<sup>b</sup>  
 Terms and usage . . . . . 2188<sup>b</sup>
- Omnipresence . . . . . 2190<sup>a</sup> (Vos)  
 Negative views . . . . . 2190<sup>a</sup>  
 Non-occurrence of the  
 term . . . . . 2190<sup>a</sup>  
 Philosophical and pop-  
 ular ideas of . . . . . 2190<sup>a</sup>  
 Presence of God . . . . . 2190<sup>b</sup>  
 Religious significance . . . . . 2190<sup>b</sup>
- Omniscience . . . . . 2191<sup>a</sup> (Vos)  
 Extent and mode . . . . . 2191<sup>a</sup>  
 cf Foreknow . . . . . 1128<sup>a</sup> (Hodge)  
 Free will and . . . . . 2191<sup>b</sup>  
 cf Infinite . . . . . 1467<sup>a</sup> (Orr)  
 Religious importance . . . . . 2192<sup>a</sup>  
 Terms and usage . . . . . 2191<sup>a</sup>
- Omri . . . . . 2192<sup>a</sup> (Mosiman)  
 Accession . . . . . 2192<sup>a</sup>  
 Foreign policy . . . . . 2192<sup>b</sup>  
 Founding of Samaria . . . . . 2192<sup>b</sup>  
 Religious influence . . . . . 2193<sup>a</sup>
- On (Heliopolis) . . . . . 2193<sup>a</sup> (Kyle)  
 Excavations at . . . . . 2194<sup>a</sup>  
 History . . . . . 2193<sup>b</sup>  
 cf Ir-ha-heres . . . . . 1491<sup>a</sup> (Kyle)  
 Location and descrip-  
 tion . . . . . 2193<sup>a</sup>
- On (person) . . . . . 2194<sup>a</sup>
- Onam . . . . . 2194<sup>a</sup>  
 cf Onan . . . . . 2194<sup>a</sup>
- Onan . . . . . 2194<sup>a</sup>  
 cf Onam . . . . . 2194<sup>a</sup>
- One  
 cf Number . . . . . 2157<sup>a</sup> (Smith)
- Onesimus . . . . . 2194<sup>a</sup> (Rutherford)  
 Epistles to Colossae  
 and Philemon . . . . . 2194<sup>b</sup>  
 Paul's relations with . . . . . 2194<sup>a</sup>
- Onesiphorus . . . . . 2195<sup>a</sup> (Rutherford)  
 Friend of Paul . . . . . 2195<sup>a</sup>  
 Household of . . . . . 2195<sup>a</sup>  
 Visits Paul in Rome . . . . . 2195<sup>a</sup>
- Oniases . . . . . 2195<sup>b</sup>
- Onias . . . . . 2195<sup>b</sup> (Angus)
- Onions . . . . . 2196<sup>a</sup>; 1122<sup>a</sup> (Eager)
- Onkelos  
 cf Targum . . . . . 2911<sup>b</sup> (J. E. H. Thomson)
- Only Begotten . . . . . 2196<sup>a</sup> (Rees)  
 cf Begotten . . . . . 426<sup>b</sup> (Rees)  
 cf Person of Christ . . . . . 2338<sup>a</sup> (Warfield)  
 cf Son of God . . . . . 2826<sup>b</sup> (Stalker)
- Ono . . . . . 2196<sup>a</sup> (Ewing)
- Onus  
 cf Ono . . . . . 2196<sup>a</sup> (Ewing)
- Onycha . . . . . 2196<sup>a</sup> (Day)
- Onyx  
 cf Stones, Precious . . . . . 2856<sup>a</sup> (Fletcher)
- Open . . . . . 2196<sup>b</sup>
- Open Place . . . . . 2196<sup>b</sup> (Easton)  
 cf Enaim . . . . . 941<sup>b</sup> (Masterman)  
 cf Void . . . . . 3058<sup>a</sup>
- Operation . . . . . 2196<sup>b</sup>
- Ophel . . . . . 2196<sup>b</sup> (Masterman)  
 cf Hill, Hill Country . . . . . 1392<sup>a</sup> (Masterman)  
 In Jerusalem . . . . . 2197<sup>a</sup>  
 cf Jerusalem . . . . . 1601<sup>a</sup> (Masterman); 1613<sup>b</sup>  
 Meaning of name . . . . . 2196<sup>b</sup>  
 Three places men-  
 tioned . . . . . 2197<sup>a</sup>  
 cf Zion . . . . . 3152<sup>a</sup> (Masterman)
- Ophir . . . . . 2197<sup>b</sup> (Fulton)  
 Geographical position . . . . . 2197<sup>b</sup>  
 Probably Southern  
 Arabia . . . . . 2197<sup>b</sup>  
 Scripture references . . . . . 2197<sup>b</sup>
- Ophni . . . . . 2198<sup>a</sup>
- Ophrah . . . . . 2198<sup>a</sup> (Ewing)
- Opinion . . . . . 2198<sup>a</sup> (W. L. Walker)

- Opis . . . . . 365<sup>b</sup> (Clay)
- Oprobalsamum  
 cf Stacte . . . . . 2847<sup>b</sup>
- Oppression . . . . . 2198<sup>b</sup> (McGlothlin)
- Or . . . . . 2198<sup>b</sup>
- Oracle . . . . . 2198<sup>b</sup> (Easton)  
 cf Burden . . . . . 528<sup>b</sup> (Trever)  
 cf Divination . . . . . 860<sup>a</sup> (T. W. Davies)
- Oracles, Sibylline  
 cf Apocalyptic Literature . . . . . 161<sup>b</sup> (J. E. H. Thomson)
- Orator, Oration . . . . . 2199<sup>a</sup> (Edwards)  
 cf Divination . . . . . 860<sup>a</sup> (T. W. Davies)  
 cf Enchantment . . . . . 942<sup>a</sup> (Pratt)
- Orchard . . . . . 2199<sup>a</sup>  
 cf Paradise . . . . . 2246<sup>a</sup> (Wright)
- Ordain, Ordination . . . . . 2199<sup>a</sup> (Edwards)  
 Biblical references . . . . . 2199<sup>b</sup>  
 cf Hands, Imposition of 1335<sup>a</sup> (Orr)  
 Meaning of term . . . . . 2199<sup>a</sup>  
 NT usage . . . . . 2199<sup>b</sup>
- Order . . . . . 2200<sup>a</sup> (N. Isaacs)  
 Arrangement in rows. 2200<sup>a</sup>  
 Classification and likeness . . . . . 2200<sup>b</sup>  
 Regulation, command. 2200<sup>b</sup>  
 Sequence in time . . . . . 2200<sup>b</sup>
- Ordinance . . . . . 2201<sup>a</sup> (T. Lewis)  
 cf Sacraments . . . . . 2636<sup>a</sup> (Lambert)
- Ordinances of Heaven  
 cf Astronomy . . . . . 301<sup>a</sup> (Maunder)
- Ordination . . . . . 2199<sup>a</sup> (Edwards)  
 cf Hands, Imposition of 1335<sup>a</sup> (Orr)  
 cf Ordain . . . . . 2199<sup>a</sup> (Edwards)
- Oreb . . . . . 2201<sup>b</sup>  
 cf Sinai . . . . . 2802<sup>b</sup> (Conder)
- Oreb and Zeeb . . . . . 2201<sup>a</sup> (Roberts)
- Oren . . . . . 2201<sup>b</sup>
- Organ  
 cf Music . . . . . 2094<sup>b</sup> (Millar)
- Origen  
 cf Septuagint . . . . . 2726<sup>a</sup> (Thackeray)
- Original Sin  
 cf Imputation . . . . . 1462<sup>a</sup> (Hodge)
- Orion . . . . . 2201<sup>b</sup>; 312<sup>a</sup>  
 cf Nimrod . . . . . 2147<sup>b</sup> (Mack)
- Ormazd (Ahura Mazda)  
 cf Persian Religion . . . . . 2332<sup>a</sup> (Tisdall)
- Ornament . . . . . 2201<sup>b</sup> (Doolan)  
 cf Jewel . . . . . 1675<sup>b</sup> (Orr)
- Ornan  
 cf Araunah . . . . . 225<sup>b</sup>
- Orpah . . . . . 2202<sup>a</sup>
- Orphan . . . . . 2202<sup>a</sup>  
 cf Fatherless . . . . . 1101<sup>a</sup> (Edwards)
- Orthosia . . . . . 2202<sup>a</sup>
- Osnappar  
 cf Ashurbanipal . . . . . 271<sup>b</sup> (Clay); 367<sup>b</sup>
- Osspray . . . . . 2202<sup>a</sup> (Stratton-Porter)
- Ossifrage . . . . . 2202<sup>b</sup> (Stratton-Porter)
- Ostraca . . . . . 2202<sup>b</sup> (Goodspeed)  
 cf Ahio . . . . . 85<sup>b</sup> (Beecher)  
 Coptic ostraca . . . . . 2203<sup>a</sup>  
 Greek ostraca . . . . . 2203<sup>a</sup>  
 Hebrew ostraca . . . . . 2202<sup>b</sup>  
 NT ostraca . . . . . 2203<sup>a</sup>  
 cf Potsherd . . . . . 2423<sup>b</sup>  
 cf Potter, Pottery . . . . . 2423<sup>b</sup> (Patch)  
 cf Writing . . . . . 3120<sup>a</sup> (Richardson)
- Ostrich . . . . . 2203<sup>a</sup> (Stratton-Porter)  
 Characteristics and peculiarities . . . . . 2203<sup>a</sup>  
 Eggs and care of young 2204<sup>a</sup>  
 OT references . . . . . 2204<sup>a</sup>  
 cf Owl . . . . . 2205<sup>b</sup> (Stratton-Porter)
- Othni . . . . . 2204<sup>b</sup>
- Othniel . . . . . 2204<sup>b</sup> (N. Isaacs)
- Othonias . . . . . 2204<sup>b</sup>
- Ouches . . . . . 2204<sup>b</sup> (Caldecott)  
 cf Stones, Precious . . . . . 2856<sup>a</sup> (Fletcher)
- Outcast . . . . . 2204<sup>b</sup>
- Outer . . . . . 2205<sup>a</sup>
- Outgoing . . . . . 2205<sup>a</sup> (Easton)
- Outlandish . . . . . 2205<sup>a</sup>
- Outrage, Outrageous . . . . . 2205<sup>a</sup>
- Outroads . . . . . 2205<sup>a</sup>
- Outward Man . . . . . 2205<sup>a</sup>  
 cf Man, Natural . . . . . 1974<sup>a</sup> (Webb)  
 cf Man, New . . . . . 1975<sup>a</sup> (Webb)
- Oven  
 cf Bread . . . . . 514<sup>b</sup> (Eager)  
 cf Furnace . . . . . 1149<sup>b</sup> (Eager)
- Overcharge . . . . . 2205<sup>a</sup>
- Overpass . . . . . 2205<sup>a</sup>
- Overplus . . . . . 2205<sup>a</sup>
- Overseer . . . . . 2205<sup>b</sup>  
 cf Bishop . . . . . 478<sup>b</sup> (Dosker)
- Owl . . . . . 2205<sup>b</sup> (Stratton-Porter)  
 Biblical references . . . . . 2206<sup>a</sup>  
 Characteristics . . . . . 2205<sup>b</sup>  
 cf Hedgehog . . . . . 1367<sup>a</sup>  
 cf Ibis . . . . . 1446<sup>a</sup>  
 cf Nest . . . . . 2138<sup>b</sup> (Stratton-Porter)  
 cf Ostrich . . . . . 2203<sup>a</sup> (Stratton-Porter)  
 cf Owl, Great . . . . . 2206<sup>a</sup> (Stratton-Porter)  
 cf Owl, Little . . . . . 2206<sup>a</sup>  
 cf Porcupine . . . . . 2421<sup>b</sup> (Day)  
 cf Serpent . . . . . 2737<sup>b</sup> (Day)
- Owl, Great . . . . . 2206<sup>a</sup> (Stratton-Porter)  
 cf Owl . . . . . 2205<sup>b</sup> (Stratton-Porter)
- Owl, Little . . . . . 2206<sup>a</sup>  
 cf Owl . . . . . 2205<sup>b</sup> (Stratton-Porter)
- Owl, Screech  
 cf Night-monster . . . . . 2143<sup>b</sup> (Sweet)
- Owner  
 cf Ships and Boats . . . . . 2774<sup>a</sup> (Nicol)
- Ox  
 cf Antelope . . . . . 143<sup>b</sup> (Day)



Ox—*continued*

- cf Cattle . . . . . 583<sup>b</sup> (Day)  
 cf Wild Ox . . . . . 3084<sup>b</sup> (Day)  
 Ox (person) . . . . . 2206<sup>b</sup>  
 Ox-goad  
 cf Goad . . . . . 1248<sup>b</sup> (Patch)  
 Oxyrhynchus  
 cf Papyrus . . . . . 2240<sup>b</sup> (Goodspeed)  
 Ozem . . . . . 2206<sup>b</sup>  
 Ozias . . . . . 2206<sup>b</sup>  
 cf Uzziah . . . . . 3043<sup>b</sup> (Caldecott)  
 Oziel . . . . . 2206<sup>b</sup>  
 Ozni . . . . . 2206<sup>b</sup>  
 Oznites . . . . . 2206<sup>b</sup>  
 cf Ozni . . . . . 2206<sup>b</sup>  
 Ozora (Ezora) . . . . . 1082<sup>a</sup>  
 Paarai . . . . . 2206<sup>a</sup>  
 Pacatiana . . . . . 2206<sup>a</sup>  
 cf Phrygia . . . . . 2392<sup>a</sup> (Banks)  
 Pace . . . . . 2206<sup>a</sup>  
 Pachon . . . . . 2206<sup>b</sup>  
 Paddan . . . . . 2206<sup>b</sup>  
 cf Paddan-aram . . . . . 2206<sup>b</sup> (Christie)  
 Paddan-aram . . . . . 2206<sup>b</sup> (Christie)  
 cf Aram . . . . . 222<sup>a</sup>  
 cf Laban . . . . . 1819<sup>a</sup> (Boyd)  
 Paddle . . . . . 2207<sup>a</sup>  
 Padon . . . . . 2207<sup>a</sup>  
 cf Nethinim . . . . . 2139<sup>b</sup> (Lees)  
 cf Phaleas . . . . . 2358<sup>b</sup>  
 Pagiē . . . . . 2207<sup>a</sup> (Wallace)  
 Pahath-moab . . . . . 2207<sup>a</sup> (Wallace)  
 cf Manasseh . . . . . 1977<sup>a</sup> (Wallace)  
 cf Phaath Moab . . . . . 2358<sup>b</sup> (Angus)  
 Pai . . . . . 2207<sup>a</sup>  
 Pain . . . . . 2207<sup>a</sup> (Macalister)  
 cf Palsy . . . . . 2236<sup>a</sup> (Macalister)  
 Painfulness . . . . . 2207<sup>b</sup> (Macalister)  
 Paint . . . . . 2208<sup>a</sup> (Crannell)  
 cf Color . . . . . 674<sup>b</sup> (Patch)  
 Painting  
 cf Crafts . . . . . 734<sup>a</sup> (Patch)  
 Pair . . . . . 2208<sup>a</sup>  
 Palace . . . . . 2208<sup>a</sup> (Orr)  
 cf House . . . . . 1434<sup>b</sup> (A. C. Dickie)  
 cf Judgment, Hall of . . . . . 1777<sup>b</sup> (Rutherford)  
 cf Temple . . . . . 2930<sup>a</sup> (Caldecott; Orr)  
 Palaestra, Palestra  
 cf Games . . . . . 1168<sup>b</sup> (Smith)  
 Palal . . . . . 2208<sup>a</sup>  
 Palanquin . . . . . 2208<sup>a</sup>  
 cf Litter . . . . . 1905<sup>a</sup>  
 Palestina . . . . . 2208<sup>b</sup>  
 cf Philistia . . . . . 2376<sup>a</sup> (Porter)  
 Palestine . . . . . 2208<sup>b</sup> (Conder)  
 cf Asmoneans . . . . . 283<sup>a</sup> (Dosker)  
 cf Eglath-shelishiyah . . . . . 905<sup>b</sup> (Ewing)  
 cf Exodus, The . . . . . 1052<sup>a</sup> (Conder)  
 cf Galilee . . . . . 1163<sup>a</sup> (Ewing)  
 cf Gallery . . . . . 1167<sup>a</sup> (N. Isaacs)  
 cf Geology of Palestine . . . . . 1215<sup>b</sup> (Day)

Palestine—*continued*

- cf Hill, Hill Country . . . . . 1392<sup>a</sup> (Masterman)  
 In Historical Books of  
 OT . . . . . 2212<sup>a</sup>  
 Books of Kings . . . . . 2217<sup>a</sup>  
 Joshua, Book of . . . . . 2212<sup>a</sup>  
 Judges, Book of . . . . . 2213<sup>a</sup>  
 Post-exilic histories . . . . . 2218<sup>a</sup>  
 Ruth, Book of . . . . . 2214<sup>b</sup>  
 Samuel, Books of . . . . . 2214<sup>b</sup>  
 cf Hittites . . . . . 1395<sup>b</sup> (Conder)  
 cf Jerusalem . . . . . 1596<sup>b</sup> (Masterman)  
 cf Jesus Christ . . . . . 1627<sup>a</sup> (Orr)  
 cf Jordan River . . . . . 1732<sup>b</sup> (Wright)  
 cf Lachish . . . . . 1820<sup>a</sup> (Porter)  
 Literature on . . . . . 2222<sup>b</sup>  
 New Testament locali-  
 ties . . . . . 2220<sup>b</sup>  
 Acts . . . . . 2222<sup>b</sup>  
 Fourth Gospel . . . . . 2222<sup>a</sup>  
 Galilean localities . . . . . 2221<sup>a</sup>  
 Galilean scenery . . . . . 2221<sup>a</sup>  
 Synoptic Gospels . . . . . 2220<sup>b</sup>  
 Palestine in the Apoc-  
 rypha . . . . . 2220<sup>a</sup>  
 Judith . . . . . 2220<sup>a</sup>  
 Maccabees, Books of . . . . . 2220<sup>b</sup>  
 cf Palestine, Recent  
 Exploration . . . . . 2222<sup>b</sup> (Cobern)  
 Pentateuchal refer-  
 ences . . . . . 2210<sup>a</sup>  
 Geography of Deu-  
 teronomy . . . . . 2211<sup>b</sup>  
 Geography of Exo-  
 dus and Leviticus . . . . . 2211<sup>b</sup>  
 Geography of Genesis . . . . . 2211<sup>a</sup>  
 Geography of Num-  
 bers . . . . . 2211<sup>b</sup>  
 Places visited by  
 Abraham . . . . . 2210<sup>a</sup>  
 Places visited by  
 Jacob . . . . . 2210<sup>b</sup>  
 Physical conditions . . . . . 2208<sup>b</sup>  
 Climate . . . . . 2209<sup>b</sup>  
 Drought and famine . . . . . 2210<sup>a</sup>  
 Flora and fauna . . . . . 2209<sup>b</sup>  
 Geographical fea-  
 tures . . . . . 2208<sup>b</sup>  
 Geology . . . . . 2209<sup>a</sup>  
 Rainfall . . . . . 2209<sup>b</sup>  
 Water supply . . . . . 2209<sup>a</sup>  
 In Poetic Books of OT . . . . . 2218<sup>a</sup>  
 Job, Book of . . . . . 2218<sup>a</sup>  
 Proverbs, Book of . . . . . 2218<sup>b</sup>  
 Psalms, Book of . . . . . 2218<sup>b</sup>  
 Song of Songs . . . . . 2218<sup>b</sup>  
 cf Song of Songs . . . . . 2831<sup>a</sup> (Sampey)  
 In Prophetic Books . . . . . 2219<sup>a</sup>  
 Ezekiel . . . . . 2219<sup>b</sup>  
 Isaiah . . . . . 2219<sup>a</sup>  
 Jeremiah . . . . . 2219<sup>b</sup>  
 Minor prophets . . . . . 2220<sup>a</sup>  
 cf Syria . . . . . 2881<sup>a</sup> (Christie)

- Palestine, Recent Ex-  
 ploration . . . . . 2222<sup>b</sup> (Cobern)  
 cf Ashtoreth . . . . . 270<sup>b</sup> (Sayce)  
 Dead Sea . . . . . 2223<sup>a</sup>  
 Era of preparation . . . . . 2223<sup>a</sup>  
   Outside of Palestine . . . . . 2223<sup>a</sup>  
   In Palestine . . . . . 2223<sup>b</sup>  
 Era of scientific exca-  
 vation . . . . . 2225<sup>b</sup>  
   Central Palestine . . . . . 2230<sup>b</sup>  
   Eastern Palestine . . . . . 2230<sup>a</sup>  
   Gath . . . . . 2227<sup>a</sup>  
   Gezer . . . . . 2231<sup>b</sup>  
   Jericho . . . . . 2229<sup>b</sup>  
   Jerusalem . . . . . 2226<sup>b</sup>  
   Mareshah . . . . . 2227<sup>a</sup>  
   Megiddo . . . . . 2229<sup>a</sup>  
   Northern Palestine . . . . . 2228<sup>a</sup>  
   Samaria . . . . . 2230<sup>b</sup>  
   Shephelah, the . . . . . 2227<sup>a</sup>  
   Southern Palestine . . . . . 2225<sup>b</sup>  
   Taanach . . . . . 2228<sup>a</sup>  
   Tell el-Hesi (La-  
   chish) . . . . . 2225<sup>b</sup>  
   cf Lachish . . . . . 1820<sup>a</sup> (Porter)  
   Tell Hûm (Caper-  
   naum) . . . . . 2229<sup>b</sup>  
 Era of scientific ex-  
 ploration . . . . . 2224<sup>a</sup>  
   Coöperative explora-  
   tion . . . . . 2224<sup>b</sup>  
   Individual enter-  
   prises . . . . . 2224<sup>a</sup>  
   Most recent results . . . . . 2225<sup>a</sup>  
   cf Gezer . . . . . 1222<sup>a</sup> (Masterman)  
   cf Images . . . . . 1452<sup>a</sup> (Cobern)  
   cf Jericho . . . . . 1592<sup>a</sup> (Wright)  
   cf Jerusalem . . . . . 1601<sup>b</sup> (Masterman)  
   cf Philistines . . . . . 2376<sup>b</sup> (Conder)
- Palestra  
   cf Games . . . . . 1168<sup>b</sup> (Smith)
- Pallu, Palluites . . . . . 2235<sup>a</sup>  
   cf Peleth . . . . . 2297<sup>a</sup>
- Palm of the Hand . . . . . 2235<sup>a</sup> (Luering)  
   cf Hand . . . . . 1333<sup>b</sup> (Luering)  
   cf Paw . . . . . 2293<sup>a</sup> (Luering)
- Palm Tree . . . . . 2235<sup>a</sup> (Masterman)  
   Abundance in Pales-  
   tine . . . . . 2236<sup>a</sup>  
   Name and references . . . . . 2235<sup>a</sup>  
   Palm branches . . . . . 2236<sup>a</sup>  
   Symbolic use . . . . . 2235<sup>b</sup>  
   cf Tamar . . . . . 2907<sup>b</sup> (Ewing)
- Palmer-worm . . . . . 2236<sup>a</sup>  
   cf Insects . . . . . 1473<sup>a</sup> (Day)  
   cf Locust . . . . . 1907<sup>b</sup> (Day)
- Palsied  
   cf Feeble Knees . . . . . 1104<sup>b</sup> (Luering)
- Palsy . . . . . 2236<sup>a</sup> (Macalister)  
   cf Pain . . . . . 2207<sup>a</sup> (Macalister)
- Palti . . . . . 2236<sup>b</sup>
- Paltiel . . . . . 2236<sup>b</sup>  
   cf Phaltiel . . . . . 2358<sup>b</sup>
- Paltite . . . . . 2236<sup>b</sup>  
   cf Pelonite . . . . . 2297<sup>b</sup>
- Pamphylia . . . . . 2236<sup>b</sup> (Banks)  
   cf Attalia . . . . . 328<sup>a</sup> (Banks)  
   Importance . . . . . 2237<sup>a</sup>  
   Introduction of Chris-  
   tianity . . . . . 2237<sup>a</sup>  
   cf Perga . . . . . 2322<sup>a</sup> (Banks)  
   Physical features . . . . . 2236<sup>b</sup>  
   cf Side . . . . . 2785<sup>a</sup> (Banks)
- Pan . . . . . 2237<sup>a</sup> (Betteridge)  
   cf Pot . . . . . 2423<sup>a</sup> (Betteridge)
- Pannag . . . . . 2237<sup>b</sup> (Masterman)  
   cf Honey . . . . . 1418<sup>b</sup> (Patch)
- Panoply  
   cf Armor, Arms . . . . . 251<sup>a</sup> (Nicol)
- Pap . . . . . 2237<sup>b</sup>  
   cf Teat . . . . . 2923<sup>b</sup>
- Papal Infallibility . . . . . 338<sup>b</sup> (Rees)
- Paper  
   cf Crafts . . . . . 734<sup>a</sup> (Patch)  
   cf Papyrus . . . . . 2238<sup>b</sup> (Goodspeed)  
   cf Reed . . . . . 2544<sup>a</sup> (Masterman)  
   cf Writing . . . . . 3114<sup>a</sup> (Richardson)
- Paper Reeds . . . . . 2237<sup>b</sup>
- Paphos . . . . . 2237<sup>b</sup> (Tod)  
   cf Cyprus . . . . . 771<sup>a</sup> (Tod)  
   History of New Pa-  
   phos . . . . . 2238<sup>a</sup>  
   History of Old Paphos . . . . . 2237<sup>b</sup>  
   Site . . . . . 2237<sup>b</sup>  
   Temple and cult . . . . . 2238<sup>a</sup>  
   Visit of the apostles . . . . . 2238<sup>b</sup>
- Papias  
   cf Literature, Sub-  
   apos . . . . . 1901<sup>a</sup> (Cowan)  
   cf Mark, Gospel of . . . . . 1989<sup>b</sup> (Farmer)  
   cf Matthew, Gospel of . . . . . 2010<sup>a</sup> (Schodde)  
   Testimony regarding  
   Apostle John . . . . . 1707<sup>b</sup> (Iverach)
- Papyrus . . . . . 2238<sup>b</sup> (Goodspeed)  
   Aramaic papyri . . . . . 2239<sup>a</sup>  
   Chief collections . . . . . 2242<sup>b</sup>  
   Classical papyri . . . . . 2241<sup>a</sup>  
   Contribution to NT  
   study . . . . . 2242<sup>b</sup>  
   Coptic, Arabic and  
   other papyri . . . . . 2243<sup>a</sup>  
   Discovery of papyri . . . . . 2239<sup>b</sup>  
   Documentary papyri . . . . . 2242<sup>a</sup>  
   Egyptian papyri . . . . . 2239<sup>a</sup>  
   Greek papyri . . . . . 2239<sup>b</sup>  
   cf Jordan . . . . . 1733<sup>a</sup> (Wright)  
   cf Jordan Valley . . . . . 1736<sup>b</sup> (Wright)  
   cf Language of NT . . . . . 1828<sup>a</sup> (A. T. Robertson)  
   cf Logia . . . . . 1910<sup>a</sup> (Smith)  
   NT papyri . . . . . 2242<sup>a</sup>  
   cf Palestine, Recent  
   Exploration . . . . . 2223<sup>b</sup> (Cobern)
- Papyrus paper . . . . . 2238<sup>b</sup>

- Papyrus—*continued*  
 cf Reed . . . . . 2544<sup>a</sup> (Masterman)  
 Septuagint papyri . . . . . 2241<sup>a</sup>  
 cf Sevehneh . . . . . 2744<sup>a</sup>  
 cf Ships and Boats . . . . . 2774<sup>a</sup> (Nicol)  
 cf Texts and Manuscripts of the NT . . . . . 2951<sup>a</sup> (Sitterly)  
 Theological papyri . . . . . 2242<sup>a</sup>  
 cf Writing . . . . . 3122<sup>a</sup> (Richardson)
- Papyrus, Vessels of  
 cf Ships and Boats . . . . . 2774<sup>a</sup> (Nicol)
- Parable . . . . . 2243<sup>a</sup> (Schodde)  
 Christ's purpose in using the . . . . . 2243<sup>b</sup>  
 Christ's use of the . . . . . 2243<sup>b</sup>  
 Doctrinal value of the . . . . . 2244<sup>b</sup>  
 cf Fable . . . . . 1085<sup>a</sup> (Easton)  
 Historical data . . . . . 2243<sup>b</sup>  
 Interpretation of the . . . . . 2244<sup>a</sup>  
 cf Jesus Christ . . . . . 1645<sup>a</sup> (Orr)  
 Name . . . . . 2243<sup>a</sup>
- Paraclete . . . . . 2245<sup>a</sup> (Mullins)  
 cf Advocate . . . . . 65<sup>a</sup> (Mullins)  
 As applied to Christ . . . . . 2246<sup>a</sup>  
 Christ's use of the word . . . . . 2245<sup>b</sup>  
 General meaning . . . . . 2245<sup>a</sup>  
 cf Holy Spirit . . . . . 1406<sup>a</sup> (Mullins)  
 Philo's use of the word . . . . . 2245<sup>a</sup>  
 Talmud and Targums . . . . . 2245<sup>a</sup>  
 Translation, the best . . . . . 2245<sup>b</sup>  
 Word and usage . . . . . 2245<sup>a</sup>
- Paradise . . . . . 2246<sup>a</sup> (Wright)  
 cf Abraham's Bosom . . . . . 22<sup>b</sup> (Orr)  
 cf Apocalyptic Literature . . . . . 161<sup>b</sup> (J. E. H. Thomson)  
 cf Eschatology of NT . . . . . 979<sup>b</sup> (Vos)  
 cf Eschatology of OT . . . . . 972<sup>a</sup> (Orr)  
 Forms and uses . . . . . 2246<sup>b</sup>  
 cf Garden . . . . . 1174<sup>a</sup> (Patch)  
 cf Hades . . . . . 1314<sup>b</sup> (Vos)  
 cf Orchard . . . . . 2199<sup>a</sup>  
 Origin and meaning . . . . . 2246<sup>a</sup>  
 cf Park . . . . . 2248<sup>b</sup> (Day)  
 Use in Jewish literature . . . . . 2246<sup>b</sup>  
 Used by Christ . . . . . 2246<sup>b</sup>
- Parah . . . . . 2247<sup>a</sup>
- Paralysis, Paralytic  
 cf Pain . . . . . 2207<sup>a</sup> (Macalister)  
 cf Palsy . . . . . 2236<sup>a</sup> (Macalister)
- Paramour . . . . . 2247<sup>a</sup>
- Paran . . . . . 2247<sup>a</sup> (Ewing)
- Parbar . . . . . 2247<sup>a</sup> (Masterman)
- Parcel . . . . . 2247<sup>b</sup>
- Parched . . . . . 2247<sup>b</sup> (Patch); 1307<sup>a</sup>  
     (W. L. Walker)  
 cf Mirage . . . . . 2066<sup>a</sup> (Joy)
- Parched Corn  
 cf Food . . . . . 1121<sup>b</sup> (Eager)
- Parchment . . . . . 2247<sup>b</sup> (Patch)  
 cf Tanner . . . . . 2908<sup>b</sup> (Patch)  
 cf Writing . . . . . 3121<sup>b</sup> (Richardson)
- Parchments . . . . . 2248<sup>a</sup> (Rutherford)
- Pardon  
 cf Forgiveness . . . . . 1132<sup>b</sup> (Morro)
- Pare (Nails) . . . . . 2248<sup>b</sup>  
 cf Nail . . . . . 2111<sup>a</sup> (Orr)
- Parent  
 cf Crimes against . . . . . 747<sup>b</sup> (Hirsch)  
 cf Education . . . . . 900<sup>b</sup> (Meyer)  
 cf Family . . . . . 1094<sup>b</sup> (Caverno)  
 cf Punishments . . . . . 2504<sup>b</sup> (Hirsch)
- Park . . . . . 2248<sup>b</sup> (Day)  
 cf Paradise . . . . . 2246<sup>a</sup> (Wright)
- Parlor . . . . . 2248<sup>b</sup>  
 cf House . . . . . 1434<sup>b</sup> (A. C. Dickie)
- Parmashta . . . . . 2248<sup>b</sup>
- Parmenas . . . . . 2248<sup>b</sup>
- Parnach . . . . . 2248<sup>b</sup>
- Parosh . . . . . 2248<sup>b</sup>  
 cf Pedaiah . . . . . 2294<sup>b</sup> (Wallace)  
 cf Phoros . . . . . 2392<sup>a</sup>
- Parousia . . . . . 2249<sup>a</sup> (Easton)  
 cf Antichrist . . . . . 154<sup>a</sup> (J. E. H. Thomson)  
 Apostolic doctrine . . . . . 2249<sup>a</sup>  
 Church a Divine quantity . . . . . 2251<sup>b</sup>  
 Critical problems . . . . . 2250<sup>a</sup>  
 Data and sources . . . . . 2249<sup>a</sup>  
 cf Day of the Lord . . . . . 799<sup>a</sup> (Dosker)  
 cf Eschatology, NT and OT . . . . . 979<sup>b</sup> (Vos); 972<sup>a</sup> (Orr)  
 Fall of Jerusalem . . . . . 2250<sup>b</sup>  
 cf Hell . . . . . 1371<sup>a</sup> (Orr)  
 cf Hope . . . . . 1419<sup>b</sup> (Easton)  
 Johannine solution . . . . . 2251<sup>a</sup>  
 Johannine teaching . . . . . 2251<sup>a</sup>  
 cf Johannine Theology 1705<sup>b</sup> (Law)  
 cf Judgment, Last . . . . . 1777<sup>b</sup> (Easton)  
 cf Kenosis . . . . . 1792<sup>a</sup> (Easton)  
 cf Kingdom of God . . . . . 1805<sup>a</sup> (Stalker)  
 cf Millennium . . . . . 2052<sup>b</sup> (Moorehead)  
 cf Pauline Theology . . . . . 2289<sup>a</sup> (Easton)  
 cf Presence . . . . . 2438<sup>a</sup> (Easton)  
 cf Resurrection . . . . . 2562<sup>a</sup> (Easton)  
 Symbolism of . . . . . 2250<sup>a</sup>  
 Teaching of Jesus . . . . . 2250<sup>a</sup>  
 Terms . . . . . 2249<sup>a</sup>  
 Time of . . . . . 2251<sup>a</sup>  
 Varieties of view . . . . . 2250<sup>a</sup>  
 cf Zoroastrianism . . . . . 3157<sup>a</sup> (Easton)
- Parshandatha . . . . . 2251<sup>b</sup>
- Part . . . . . 2251<sup>b</sup>  
 cf Portion . . . . . 2422<sup>b</sup> (Easton)
- Part Asunder . . . . . 316<sup>b</sup> (S. F. Hunter)
- Parthians . . . . . 2251<sup>b</sup> (Porter)  
 Country and early history . . . . . 2251<sup>b</sup>  
 Culture . . . . . 2253<sup>a</sup>  
 Relations with Rome . . . . . 2252<sup>b</sup>  
 cf Scythians . . . . . 2706<sup>a</sup> (Porter)  
 Seleucid kings . . . . . 2252<sup>a</sup>
- Particular, Particularly . . . . . 2253<sup>a</sup> (Edwards)
- Partition, The Middle  
 Wall of . . . . . 2253<sup>a</sup> (Rutherford)

Partition—*continued*

- Barrier in the temple. 2253<sup>b</sup>  
 Court of Gentiles. . . . . 2253<sup>b</sup>  
 Herod's temple. . . . . 2253<sup>b</sup>  
 of Temple. . . . . 2937<sup>a</sup> (Caldecott; Orr)  
 Throwing down the  
 barrier. . . . . 2254<sup>a</sup>  
 Warning stone, the. . . . . 2253<sup>b</sup>  
 Partridge. . . . . 2254<sup>a</sup> (Stratton-Porter)  
 of Food. . . . . 1124<sup>a</sup> (Eager)  
 of Quail. . . . . 2512<sup>a</sup> (Stratton-Porter)  
 Paruah. . . . . 2255<sup>a</sup>  
 Parvaim. . . . . 2255<sup>a</sup> (Fulton)  
 Pasach. . . . . 2255<sup>a</sup>  
 Pas-dammim  
 of Ephes-dammim. . . . . 956<sup>a</sup> (Masterman)  
 Paseah. . . . . 2255<sup>a</sup>; 2365<sup>b</sup>  
 of Phinoe. . . . . 2385<sup>b</sup>  
 Pashhur, Pashur. . . . . 2255<sup>a</sup> (Wallace)  
 Pass, Passage, Passenger. . . . . 2255<sup>b</sup> (T. Lewis)  
 Passing of Mary, The  
 of Apocryphal Gospels. . . . . 195<sup>a</sup> (Hutchison)  
 Passion, Gospel of the  
 of Apocryphal Gospels. . . . . 195<sup>a</sup> (Hutchison)  
 Passion, Passions. . . . . 2255<sup>b</sup> (Easton)  
 of Affection. . . . . 65<sup>b</sup> (Edwards)  
 of Passover. . . . . 2256<sup>a</sup> (N. Isaacs)  
 Passover. . . . . 2256<sup>a</sup> (N. Isaacs)  
 Critical views of the  
 sources. . . . . 2257<sup>b</sup>  
 Development of the  
 feast. . . . . 2257<sup>b</sup>  
 Importance in NT  
 times. . . . . 2257<sup>b</sup>  
 of Jesus Christ (Lord's  
 Supper). . . . . 1658<sup>b</sup> (Orr)  
 Modern celebration. . . . . 2258<sup>a</sup>  
 of Moses. . . . . 2085<sup>b</sup> (Kyle)  
 Name and meaning. . . . . 2256<sup>a</sup>  
 Offerings of. . . . . 2257<sup>a</sup>  
 Order of events. . . . . 2256<sup>b</sup>  
 Origins. . . . . 2257<sup>a</sup>  
 of Passion. . . . . 2255<sup>b</sup> (Easton)  
 References in OT. . . . . 2256<sup>b</sup>  
 Unleavened bread. . . . . 2256<sup>b</sup>  
 of Worship. . . . . 3111<sup>a</sup> (Crannell)  
 Pastor. . . . . 2258<sup>b</sup>  
 of Ministry. . . . . 2057<sup>a</sup> (T. M. Lindsay)  
 Pastoral Epistles, The. . . . . 2258<sup>b</sup> (Rutherford)  
 Date and order. . . . . 2262<sup>a</sup>  
 Defined. . . . . 2258<sup>b</sup>  
 Difficulties with the  
 language. . . . . 2261<sup>a</sup>  
 Difficulties against  
 Pauline authorship. . . . . 2259<sup>a</sup>  
 Genuineness. . . . . 2258<sup>b</sup>  
 Not the Christianity  
 of Paul. . . . . 2261<sup>a</sup>  
 of Paul, the Apostle. . . . . 2265<sup>a</sup>; 2267<sup>a</sup> (A. T. Robertson)  
 Paul's relation to. . . . . 2259<sup>a</sup>  
 of Persecution. . . . . 2325<sup>a</sup> (Rutherford)
- Pastoral Epistles, The—*continued*  
 Subject-matter, post-  
 Pauline. . . . . 2260<sup>b</sup>  
 Pasturage, Pasture  
 of Herdsman. . . . . 1375<sup>b</sup> (Patch)  
 of Sheep Tending. . . . . 2758<sup>a</sup> (Patch)  
 Patara. . . . . 2262<sup>b</sup> (Banks)  
 of Myra. . . . . 2102<sup>b</sup> (Banks)  
 Pate. . . . . 2263<sup>a</sup> (Luering)  
 Path, Pathway. . . . . 2263<sup>a</sup> (Edwards)  
 of Way. . . . . 3075<sup>b</sup> (Morro)  
 Patheus. . . . . 2263<sup>a</sup>  
 Pathros. . . . . 2263<sup>a</sup>  
 Pathrusim. . . . . 2263<sup>a</sup>  
 Patience. . . . . 2263<sup>b</sup> (W. L. Walker)  
 of God. . . . . 1250<sup>a</sup> (Rees)  
 of Longsuffering. . . . . 1918<sup>a</sup> (W. L. Walker)  
 Patmos. . . . . 2263<sup>b</sup> (Harry)  
 of John, the Apostle. . . . . 1706<sup>b</sup> (Iverach)  
 of Revelation of John. . . . . 2582<sup>b</sup> (Orr)  
 Patriarch, Patriarchs. . . . . 2264<sup>a</sup> (Orr)  
 of Antediluvian Patri-  
 archs. . . . . 139<sup>a</sup> (Davis)  
 of Genealogy. . . . . 1183<sup>b</sup> (Crannell)  
 Patriarchs, Antediluvian. . . . . 139<sup>a</sup> (Davis)  
 Patriarchs, Testaments of  
 the Twelve  
 of Apocalyptic Litera-  
 ture. . . . . 161<sup>b</sup> (J. E. H. Thomson)  
 Patrimony. . . . . 2264<sup>a</sup> (Maek)  
 of Birthright. . . . . 478<sup>a</sup> (J. M. Wilson)  
 of Family. . . . . 1094<sup>b</sup> (Caverno)  
 of Inheritance. . . . . 1468<sup>b</sup> (Hirsch)  
 Patristic Writings  
 Antichrist in. . . . . 155<sup>b</sup> (J. E. H. Thomson)  
 Patrobas. . . . . 2264<sup>a</sup>  
 Patroclus. . . . . 2264<sup>a</sup>  
 Pattern. . . . . 2264<sup>b</sup> (Patch)  
 Pau  
 of Pai. . . . . 2207<sup>a</sup>  
 Paul, the Apostle. . . . . 2264<sup>b</sup> (A. T. Robertson)  
 Antichrist in Epistles. . . . . 154<sup>b</sup> (J. E. H. Thomson)  
 Baptism. . . . . 397<sup>a</sup> (Dau)  
 Barnabas. . . . . 405<sup>b</sup> (Jacobs)  
 Chronology. . . . . 2270<sup>b</sup>  
 Crucial points. . . . . 2271<sup>a</sup>  
 Different schemes. . . . . 2270<sup>b</sup>  
 of Chronology of NT. . . . . 644<sup>b</sup> (Armstrong)  
 Controversy with Ga-  
 latians. . . . . 1157<sup>b</sup> (G. G. Findlay)  
 At Derbe. . . . . 831<sup>a</sup> (Calder)  
 Doctrine of Logos. . . . . 1914<sup>a</sup> (Alexander)  
 Epistle to Philemon. . . . . 2366<sup>b</sup> (C. S. Lewis)  
 Epistles of. . . . . 466<sup>a</sup> (Orr)  
 Equipment of. . . . . 2272<sup>b</sup>  
 Conversion. . . . . 2278<sup>b</sup>  
 Hellenism. . . . . 2274<sup>a</sup>  
 Judaism. . . . . 2276<sup>a</sup>  
 Mystery-religions,  
 the. . . . . 2275<sup>b</sup>  
 Personal character-  
 istics. . . . . 2277<sup>a</sup>

Paul, the Apostle—*continued*

- Equipment of—*continued*  
 Roman citizenship . . . 2273<sup>b</sup>  
 Tarsus . . . . . 2273<sup>a</sup>
- cf Faithful Sayings . . . 1091<sup>a</sup> (Rutherford)  
 And Felix . . . . . 1105<sup>b</sup> (Kerr)  
 And Festus, Porcius . . . 1107<sup>a</sup> (Kerr)  
 And Galatia . . . . . 1155<sup>a</sup> (Ramsay)  
 cf Galatians, Epistle  
 to the . . . . . 1155<sup>b</sup> (G. G. Findlay)  
 cf Gallo . . . . . 1167<sup>b</sup> (Kerr)  
 cf Gamaliel . . . . . 1168<sup>a</sup> (Kerr)  
 And Gnosticism . . . . . 1242<sup>a</sup> (Rutherford)  
 Gospel of . . . . . 2287<sup>a</sup>  
 On inspiration . . . . . 1474<sup>a</sup> (Warfield)  
 Justification in writings  
 of . . . . . 1782<sup>b</sup> (Faulkner)  
 cf Law in NT . . . . . 1847<sup>b</sup> (M'Caig)  
 Literary style . . . . . 1830<sup>b</sup> (A. T. Robertson)  
 Literature on . . . . . 2288<sup>a</sup>  
 And Luke . . . . . 41<sup>a</sup>; 42<sup>a</sup> (A. T. Robertson)  
 Lystra, Paul at . . . . . 1944<sup>b</sup> (Calder)  
 cf Macedonia . . . . . 1957<sup>b</sup> (Tod)
- Modern theories about  
 Paul . . . . . 2269<sup>a</sup>  
 Baur's successors . . . 2269<sup>b</sup>  
 Comparative religion . . . . . 2270<sup>a</sup>  
 Influence of eschatology . . . . . 2270<sup>a</sup>  
 Nature of criticism . . . 2269<sup>a</sup>  
 Tübingen theory . . . . . 2269<sup>a</sup>
- cf Mystery . . . . . 2105<sup>b</sup> (Edwards)  
 cf Persecution . . . . . 2324<sup>b</sup> (Rutherford)  
 cf Philippi . . . . . 2369<sup>b</sup> (Tod)  
 cf Philippians, Epistle  
 to . . . . . 2372<sup>a</sup> (Hayes)  
 cf Pisidia . . . . . 2401<sup>a</sup> (Calder)  
 Poetry of . . . . . 2414<sup>b</sup> (Schenk)  
 Praetorian Guard . . . . 2427<sup>b</sup> (Rutherford)  
 cf Priest, High . . . . . 2441<sup>b</sup> (Reeve)  
 Relation to Illyricum . . . . . 1450<sup>a</sup> (Tod)
- Relation to Pastoral  
 Epistles . . . . . 2259<sup>a</sup> (Rutherford)
- Relations with Mark . . . 1987<sup>a</sup> (Farmer)
- Relations with Onesimus . . . . . 2194<sup>a</sup> (Rutherford)
- Relations with Onesiphorus . . . . . 2195<sup>a</sup> (Rutherford)
- Relations with Silas . . . 2790<sup>a</sup> (Kerr)  
 Relations with Titus . . . 2988<sup>b</sup> (Rutherford)  
 As sailor . . . . . 2776<sup>b</sup> (Nicol)  
 cf Sanctification . . . . . 2684<sup>a</sup> (Rall)  
 cf Sea, The Great . . . . . 2708<sup>a</sup> (Ewing)  
 cf Sin . . . . . 2799<sup>b</sup> (McConnell)
- Sources . . . . . 2265<sup>a</sup>  
 Acts . . . . . 2265<sup>a</sup>  
 Development in the  
 Epistles . . . . . 2268<sup>a</sup>

Paul, the Apostle—*continued*

- Sources—*continued*  
 Paul's conception of  
 his Epistles . . . . . 2267<sup>a</sup>  
 Thirteen Epistles,  
 the . . . . . 2265<sup>a</sup>
- cf Spain . . . . . 2838<sup>b</sup>  
 Tarsus, his birthplace . . 2916<sup>b</sup> (Tod)
- Teachings regarding  
 Family . . . . . 1096<sup>b</sup> (Caverno)  
 Foreordination . . . . . 1130<sup>a</sup> (Hodge)  
 Grace . . . . . 1291<sup>a</sup> (Easton)  
 Guilt . . . . . 1309<sup>b</sup> (Rall)  
 Man of sin . . . . . 1975<sup>b</sup> (Orr)  
 Mediation . . . . . 2023<sup>a</sup> (Edwards)  
 Person of Christ . . . . . 2338<sup>b</sup> (Warfield)  
 The Sabbath . . . . . 2631<sup>b</sup> (Sampey)  
 Sacrifice . . . . . 2652<sup>a</sup> (Williams)
- cf 1 Thessalonians . . . . 2966<sup>a</sup> (R. H. Walker)  
 At Thessalonica . . . . . 2970<sup>b</sup> (Tod)  
 Timothy and Paul . . . . 2984<sup>a</sup> (Rutherford)
- Tradition of visit to  
 Petra . . . . . 2714<sup>b</sup> (Ewing)
- Trophimus and . . . . . 3023<sup>b</sup> (Rutherford)
- Use of "Seed" in Gal  
 3 16 . . . . . 2712<sup>b</sup> (Easton)
- Voyage and shipwreck  
 of . . . . . 2286<sup>b</sup>  
 cf Phoenix . . . . . 2391<sup>a</sup> (Calder)
- Work of . . . . . 2279<sup>b</sup>  
 Adjustment . . . . . 2279<sup>b</sup>  
 Conflict at Jerusalem . . 2282<sup>a</sup>  
 First campaign . . . . . 2281<sup>b</sup>  
 Last imprisonment . . . . 2287<sup>a</sup>  
 Later travels . . . . . 2286<sup>b</sup>  
 Opportunity . . . . . 2281<sup>a</sup>  
 Opposition . . . . . 2280<sup>a</sup>  
 Prison life . . . . . 2285<sup>b</sup>  
 Second campaign . . . . . 2283<sup>a</sup>  
 Third campaign . . . . . 2284<sup>a</sup>  
 Waiting . . . . . 2280<sup>b</sup>
- Pauline Theology . . . . . 2289<sup>a</sup> (Easton)  
 cf Church Government 653<sup>b</sup> (Forrester)  
 Conversion, the . . . . . 2290<sup>a</sup>  
 Christ . . . . . 2290<sup>a</sup>  
 Justification . . . . . 2291<sup>a</sup>  
 Mystical union . . . . . 2290<sup>b</sup>  
 Salvation . . . . . 2290<sup>b</sup>  
 Spirit, the . . . . . 2290<sup>a</sup>
- Further developments 2291<sup>a</sup>  
 Abolition of the law 2291<sup>a</sup>  
 Atonement . . . . . 2291<sup>b</sup>  
 Function of the law 2292<sup>a</sup>  
 Gentiles . . . . . 2291<sup>a</sup>  
 Moral example . . . . . 2291<sup>b</sup>  
 Redemption . . . . . 2291<sup>b</sup>
- cf God . . . . . 1250<sup>a</sup> (Rees)  
 cf Holy Spirit . . . . . 1406<sup>a</sup> (Mullins)  
 cf Messiah . . . . . 2039<sup>a</sup> (Crichton)  
 cf Ministry . . . . . 2057<sup>a</sup> (T. M. Lindsay)  
 cf Parousia . . . . . 2249<sup>a</sup> (Easton)  
 cf Pharisees . . . . . 2361<sup>a</sup> (J. E. H. Thomson)

- Pauline Theology—*continued*  
 cf Prayer . . . . . 2430<sup>a</sup> (Lambert)  
 cf Predestination . . . . . 2435<sup>a</sup> (J. Lindsay)  
 Preparation . . . . . 2289<sup>a</sup>  
 Pharisee, the . . . . . 2289<sup>a</sup>  
 Primitive Christian-  
 ity . . . . . 2289<sup>b</sup>  
 Soul and sin . . . . . 2289<sup>b</sup>  
 cf Propitiation . . . . . 2467<sup>a</sup> (Carver)  
 cf Salvation . . . . . 2665<sup>a</sup> (Easton)  
 cf Sanctification . . . . . 2290<sup>a</sup>; 2681<sup>b</sup> (Rall)  
 cf Schoolmaster . . . . . 2702<sup>b</sup> (Easton)  
 cf Sin . . . . . 2799<sup>b</sup> (McConnell)  
 Special topics . . . . . 2292<sup>a</sup>  
 The Church . . . . . 2292<sup>a</sup>  
 The Sacraments . . . . . 2292<sup>b</sup>  
 cf Trinity . . . . . 3012<sup>a</sup> (Warfield)  
 Paulus, Sergius . . . . . 2292<sup>b</sup> (Kerr)  
 Pavement . . . . . 2292<sup>b</sup>  
 cf Gabbatha . . . . . 1150<sup>b</sup> (Masterman)  
 Pavilion . . . . . 2292<sup>b</sup> (Orr)  
 Paw . . . . . 2293<sup>a</sup> (Luering)  
 cf Palm of the Hand . . . . . 2235<sup>a</sup> (Luering)  
 Pè . . . . . 2293<sup>a</sup>  
 cf Alphabet . . . . . 103<sup>b</sup> (Richardson)  
 Peace . . . . . 2293<sup>a</sup> (W. L. Walker)  
 cf Greeting . . . . . 1305<sup>a</sup> (W. L. Walker)  
 In NT . . . . . 2293<sup>b</sup>  
 In OT . . . . . 2293<sup>a</sup>  
 Peacemaker . . . . . 2293<sup>b</sup> (W. L. Walker)  
 Peace Offering  
 cf Sacrifice, OT . . . . . 2644<sup>a</sup> (Reeve)  
 Peacock . . . . . 2294<sup>a</sup> (Stratton-Porter)  
 Biblical references . . . . . 2294<sup>a</sup>  
 Characteristics . . . . . 2294<sup>a</sup>  
 cf Gold . . . . . 1274<sup>a</sup> (Patch)  
 Pearl  
 cf Stones, Precious . . . . . 2856<sup>a</sup> (Fletcher)  
 Peculiar . . . . . 2294<sup>b</sup> (Easton)  
 Pedahel . . . . . 2294<sup>b</sup>  
 Pedahzur . . . . . 2294<sup>b</sup>  
 Pedaiah . . . . . 2294<sup>b</sup> (Wallace)  
 cf Parosh . . . . . 2248<sup>b</sup>  
 cf Phaldeus . . . . . 2358<sup>b</sup>  
 Pedestal . . . . . 2295<sup>a</sup>  
 Pedias . . . . . 2295<sup>a</sup>  
 cf Bedeiah . . . . . 423<sup>a</sup>  
 Pedigree . . . . . 2295<sup>a</sup> (Betteridge)  
 Peel . . . . . 2295<sup>a</sup> (Easton)  
 Peep . . . . . 2295<sup>a</sup>  
 cf Mutter . . . . . 2102<sup>a</sup> (Easton)  
 Pekah . . . . . 2295<sup>a</sup> (Caldecott)  
 Accession . . . . . 2295<sup>a</sup>  
 Attitude toward As-  
 syria . . . . . 2295<sup>b</sup>  
 Fall of Damascus . . . . . 2295<sup>b</sup>  
 Invasion and deporta-  
 tion . . . . . 2295<sup>b</sup>  
 Pekahiah . . . . . 2296<sup>a</sup> (Caldecott)  
 cf Menahem . . . . . 2031<sup>b</sup> (Caldecott)  
 cf Uzziah . . . . . 3043<sup>b</sup> (Caldecott)  
 Pekod . . . . . 2296<sup>b</sup>  
 Pelaiah . . . . . 2296<sup>b</sup>  
 cf Phalias . . . . . 2358<sup>b</sup>  
 Pelaliah . . . . . 2296<sup>b</sup>  
 Pelatiah . . . . . 2296<sup>b</sup>  
 Peleg . . . . . 2296<sup>b</sup> (S. F. Hunter)  
 Pelet . . . . . 2297<sup>a</sup>  
 Peleth . . . . . 2297<sup>a</sup>  
 cf Pallu . . . . . 2235<sup>a</sup>  
 Pelethites . . . . . 2297<sup>a</sup>  
 cf Cherethites . . . . . 603<sup>a</sup> (Ewing)  
 cf Stranger and So-  
 journeyer (in OT) . . . . . 2865<sup>a</sup> (Wiener)  
 Pelias  
 cf Pedias . . . . . 2295<sup>a</sup>  
 Pelican . . . . . 2297<sup>a</sup> (Stratton-Porter)  
 Pelishtim . . . . . 2297<sup>b</sup>  
 cf Philistines . . . . . 2376<sup>b</sup> (Conder)  
 Pelonite . . . . . 2297<sup>b</sup>  
 cf Paltite . . . . . 2236<sup>b</sup>  
 Pen . . . . . 2297<sup>b</sup> (Patch)  
 cf Ink . . . . . 1469<sup>a</sup> (Richardson)  
 cf Ink-horn . . . . . 1469<sup>b</sup> (Richardson)  
 cf Writing . . . . . 3114<sup>a</sup> (Richardson)  
 Pence  
 cf Money . . . . . 2076<sup>a</sup> (Porter)  
 Pencil . . . . . 2298<sup>a</sup>  
 cf Line . . . . . 1894<sup>a</sup> (Orr)  
 cf Ochre, Red . . . . . 2178<sup>a</sup>  
 cf Tools . . . . . 2998<sup>b</sup> (Easton)  
 Pendant . . . . . 2298<sup>a</sup>  
 Peniel . . . . . 2298<sup>a</sup> (Ewing)  
 cf Phanuel . . . . . 2358<sup>b</sup>  
 Peninnah . . . . . 2298<sup>a</sup>  
 Penknife  
 cf Pen . . . . . 2297<sup>b</sup> (Patch)  
 Penny . . . . . 2298<sup>a</sup>  
 cf Denarius . . . . . 830<sup>a</sup> (Porter)  
 cf Farthing . . . . . 1098<sup>b</sup>  
 cf Money . . . . . 2076<sup>a</sup> (Porter)  
 Pension . . . . . 2298<sup>a</sup>  
 cf Divination . . . . . 860<sup>a</sup> (T. W. Davies)  
 Pentateuch . . . . . 2298<sup>a</sup> (Wiener); 242<sup>b</sup>  
 (Lotz); 464<sup>a</sup> (Orr)  
 cf Altar . . . . . 106<sup>b</sup> (Caldecott)  
 cf Amraphel . . . . . 366<sup>a</sup> (Clay)  
 cf Archaeology and  
 Criticism . . . . . 226<sup>a</sup> (Kyle)  
 Authorship, composi-  
 tion, date . . . . . 2299<sup>a</sup>  
 Critical views . . . . . 2299<sup>a</sup>  
 Evidence of date . . . . . 2304<sup>b</sup>  
 Evidence for modern  
 critical views . . . . . 2300<sup>a</sup>  
 Fundamental im-  
 probabilities . . . . . 2307<sup>a</sup>  
 Objections to criti-  
 cal views . . . . . 2301<sup>b</sup>  
 Origin and transmis-  
 sion . . . . . 2307<sup>b</sup>  
 Character of Penta-  
 teuch . . . . . 2311<sup>b</sup>

- Pentateuch—continued*
- Character of Pentateuch—*continued*
    - Differences . . . . . 2312<sup>a</sup>
    - Hindu law books . . . 2311<sup>b</sup>
    - Holiness . . . . . 2312<sup>a</sup>
    - Universal aspect . . . 2312<sup>b</sup>
  - Criticism of the Bible. 748<sup>b</sup> (Orr)
  - cf Genealogy . . . . . 1183<sup>b</sup> (Crannell)
  - cf Genesis . . . . . 1201<sup>b</sup> (Möller)
  - cf Hexateuch . . . . . 1385<sup>a</sup> (Wiener)
  - In history . . . . . 2309<sup>a</sup>
    - Hebrew expressions . 2309<sup>a</sup>
    - National coloring . . 2310<sup>a</sup>
    - Personification and genealogies . . . . . 2309<sup>b</sup>
    - Reasoned history . . . 2311<sup>b</sup>
    - Textual criticism . . . 2309<sup>a</sup>
    - Trustworthiness . . . 2310<sup>a</sup>
  - cf Jerusalem . . . . . 1595<sup>b</sup> (Masterman)
  - cf Law in OT . . . . . 1852<sup>a</sup> (Rule)
  - cf Moses . . . . . 2088<sup>b</sup> (Kyle)
  - cf Names, Proper . . . . 2113<sup>a</sup> (Davis)
  - cf Number . . . . . 2157<sup>a</sup> (Smith)
  - cf Priest . . . . . 2439<sup>a</sup> (Moorehead)
  - cf Priests and Levites. 2447<sup>a</sup>; 2449<sup>b</sup>; 2451<sup>a</sup> (Wiener)
  - cf Sanctuary . . . . . 2686<sup>b</sup> (Wiener)
  - cf Septuagint . . . . . 2722<sup>a</sup> (Thackeray)
  - Some literary points . . 2308<sup>a</sup>
    - Covenant, the . . . . . 2308<sup>b</sup>
    - Style of legislation . . 2308<sup>b</sup>
  - Title, division, contents . . . . . 2298<sup>b</sup>
- Pentateuch, The Samaritan* . . . . . 2312<sup>b</sup> (J. E. H. Thomson)
- Age of Nāblūs roll . . . 2314<sup>b</sup>
  - Bearing on the Pentateuchal question . . . 2317<sup>a</sup>
  - Former knowledge of . . 2313<sup>a</sup>
  - Knowledge of, revived. 2313<sup>b</sup>
  - Nāblūs roll, the . . . . . 2313<sup>b</sup>
  - Relation to LXX . . . . 2316<sup>b</sup>
  - Relation to Massoretic text . . . . . 2315<sup>a</sup>
  - cf Samaritans . . . . . 2673<sup>b</sup> (Ewing)
  - Script, the . . . . . 2313<sup>b</sup>
  - Targums and Chronicle . . . . . 2317<sup>b</sup>
- Pentecost* . . . . . 2318<sup>a</sup> (Dosker)
- cf Chronology of NT. 644<sup>b</sup> (Armstrong)
  - Later Christian observance . . . . . 2319<sup>a</sup>
  - In the NT . . . . . 2318<sup>b</sup>
  - In the OT . . . . . 2318<sup>a</sup>
- Penuel*
- cf Peniel . . . . . 2298<sup>a</sup> (Ewing)
- Penury* . . . . . 2319<sup>a</sup>
- People* . . . . . 2319<sup>a</sup>
- cf Children of the East 888<sup>b</sup> (Day)
- Peor* . . . . . 2319<sup>b</sup> (Ewing)
- cf Zimri . . . . . 3149<sup>b</sup> (Roberts)
- Peraea* . . . . . 2319<sup>b</sup> (Ewing)
- The country . . . . . 2319<sup>b</sup>
- Peraea—continued*
- cf Gilead . . . . . 1229<sup>b</sup> (Ewing)
  - The history . . . . . 2320<sup>a</sup>
  - Ministry of Jesus in . . 1651<sup>a</sup> (Orr)
- Perazim, Mount* . . . . . 2320<sup>a</sup>
- cf Baal-perazim . . . . . 347<sup>b</sup> (Masterman)
- Perdition* . . . . . 2320<sup>a</sup> (Vos)
- cf Man of Sin . . . . . 1975<sup>b</sup> (Orr)
- Peres*
- cf Mene, Mene . . . . . 2032<sup>a</sup> (R. D. Wilson)
- Peresh* . . . . . 2320<sup>b</sup>
- Perez, Pharez* . . . . . 2320<sup>b</sup> (Wallace)
- cf Phares . . . . . 2360<sup>b</sup>
- Perez-uzza*
- cf Uzza . . . . . 3043<sup>a</sup> (Roberts)
- Perfect, Perfection* . . . . 2320<sup>b</sup> (W. L. Walker)
- The Christian ideal . . . 2321<sup>a</sup>
  - In NT . . . . . 2321<sup>a</sup>
  - In OT . . . . . 2320<sup>b</sup>
- Perfector (Finisher)* . . . . 1111<sup>b</sup>
- Perform, Performance* . . . 2321<sup>b</sup> (Easton)
- Perfume, Perfumer* . . . . . 2321<sup>b</sup> (Patch)
- cf Incense . . . . . 1466<sup>b</sup> (Orr)
  - cf Oil . . . . . 2181<sup>b</sup> (Patch)
  - cf Ointment . . . . . 2183<sup>a</sup> (Patch)
  - cf Spice, Spices . . . . . 2840<sup>a</sup> (Masterman)
- Perfume-making*
- cf Crafts . . . . . 734<sup>a</sup> (Patch)
- Perga* . . . . . 2322<sup>a</sup> (Banks)
- cf Pamphylia . . . . . 2236<sup>b</sup> (Banks)
- Pergamos, Pergamum* . . . . 2322<sup>a</sup> (Banks)
- Christianity . . . . . 2323<sup>a</sup>
  - History . . . . . 2322<sup>a</sup>
  - Religions . . . . . 2322<sup>b</sup>
- Perida* . . . . . 2323<sup>a</sup>
- cf Pharida . . . . . 2361<sup>a</sup>
- Perizzite* . . . . . 2323<sup>a</sup> (Sayce)
- cf Pheresites . . . . . 2366<sup>a</sup>
  - cf Pherezite . . . . . 2366<sup>a</sup>
- Perjury*
- cf Crimes . . . . . 745<sup>b</sup> (Hirsch)
  - cf Oath . . . . . 2172<sup>b</sup> (Levertoff)
  - cf Punishments . . . . . 2504<sup>b</sup> (Hirsch)
- Perpetual, Perpetually, Perpetuity* . . . . . 2323<sup>a</sup> (W. L. Walker)
- Persecution* . . . . . 2323<sup>b</sup> (Rutherford)
- Causes of . . . . . 2326<sup>b</sup>
  - Decian persecution . . . 2327<sup>b</sup>
  - In early times . . . . . 2323<sup>b</sup>
  - Gentile persecution . . . 2324<sup>b</sup>
  - Hatred against Christians . . . . . 2327<sup>a</sup>
  - Jewish instigation . . . . 2324<sup>b</sup>
  - Libelli . . . . . 2327<sup>b</sup>
  - Neronian persecution . . 2325<sup>a</sup>
    - cf Nero . . . . . 2136<sup>b</sup> (Angus)
  - In NT times . . . . . 2324<sup>a</sup>
  - cf Pastoral Epistles . . . 2258<sup>b</sup> (Rutherford)
  - cf Paul, the Apostle . . . 2264<sup>b</sup> (A. T. Robertson)
  - Persecution in army . . . 2327<sup>a</sup>
  - Persecution in Asia . . . 2325<sup>b</sup>
  - cf Phygelus . . . . . 2392<sup>b</sup> (Rutherford)

Persecution—*continued*

- Pliny's testimony . . . . . 2326<sup>a</sup>  
 of Pontus . . . . . 2418<sup>a</sup> (White)  
 of Praise . . . . . 2429<sup>a</sup> (Lambert)  
 Results of . . . . . 2327<sup>b</sup>  
 of Roman Empire and  
 Christianity . . . . . 2604<sup>b</sup> (Angus)  
 Rome as persecutor . . . . . 2325<sup>b</sup>  
 Second and third cen-  
 turies . . . . . 2326<sup>a</sup>  
 Stephen and the  
 apostles . . . . . 2324<sup>b</sup>  
 Persepolis . . . . . 2328<sup>b</sup> (Tisdall)  
 Perseus . . . . . 2328<sup>b</sup> (Angus)  
 of Philip . . . . . 2367<sup>b</sup> (Hutchison)  
 Perseverance . . . . . 2328<sup>b</sup> (Dunelm)  
 Persia . . . . . 2329<sup>a</sup> (Tisdall)  
 of Persians . . . . . 2335<sup>a</sup> (Tisdall)  
 Persian Language and  
 Literature (Ancient) . . . . . 2329<sup>a</sup> (Tisdall)  
 Date of Avesta . . . . . 2330<sup>b</sup>  
 Divisions of Avesta . . . . . 2331<sup>a</sup>  
 Gathic . . . . . 2330<sup>a</sup>  
 Language . . . . . 2329<sup>a</sup>  
 Medic dialect . . . . . 2330<sup>a</sup>  
 Old Persian inscrip-  
 tions . . . . . 2329<sup>b</sup>  
 Ordinary Avestic . . . . . 2330<sup>a</sup>  
 Pahlavi . . . . . 2331<sup>a</sup>  
 Zoroaster . . . . . 2330<sup>b</sup>  
 Persian Religion (An-  
 cient) . . . . . 2331<sup>b</sup> (Tisdall)  
 Anro Mainyus (Ahri-  
 man), the evil one . . . . . 2333<sup>a</sup>  
 Avesta and Rig-Veda . . . . . 2331<sup>b</sup>  
 Before Zoroaster . . . . . 2331<sup>b</sup>  
 Creator, the . . . . . 2332<sup>a</sup>  
 Early Aryan religion . . . . . 2331<sup>b</sup>  
 Early traditions . . . . . 2333<sup>b</sup>  
 Eschatology . . . . . 2334<sup>b</sup>  
 Fire worship . . . . . 2334<sup>b</sup>  
 Heaven and Hell . . . . . 2334<sup>a</sup>  
 Leading principle . . . . . 2332<sup>a</sup>  
 Non-monotheistic . . . . . 2332<sup>a</sup>  
 Objects of worship . . . . . 2332<sup>b</sup>  
 of Philosophy . . . . . 2383<sup>a</sup> (Rees)  
 Production and de-  
 struction . . . . . 2333<sup>a</sup>  
 of Satan . . . . . 2696<sup>a</sup> (Sweet)  
 Treatment of dead . . . . . 2334<sup>a</sup>  
 Virgin-birth . . . . . 2334<sup>b</sup>  
 Zoroastrianism . . . . . 2332<sup>a</sup>  
 of Zoroastrianism . . . . . 3157<sup>a</sup> (Easton)  
 Persians . . . . . 2335<sup>a</sup> (Tisdall)  
 Affinity . . . . . 2335<sup>a</sup>  
 In Asia Minor . . . . . 274<sup>b</sup> (Calder)  
 Capture of Babylon . . . . . 2336<sup>a</sup>  
 Civilization . . . . . 2335<sup>b</sup>  
 Classes and clans . . . . . 2335<sup>b</sup>  
 Cyrus of Anshan . . . . . 2336<sup>a</sup>  
 Darius I . . . . . 2336<sup>b</sup>  
 History . . . . . 2336<sup>a</sup>

Persians—*continued*

- of Persia . . . . . 2329<sup>a</sup> (Tisdall)  
 of Tax . . . . . 2919<sup>b</sup> (Sweet)  
 Xerxes I . . . . . 2336<sup>b</sup>  
 Persis . . . . . 2337<sup>a</sup>  
 Person of Christ . . . . . 2338<sup>a</sup> (Warfield)  
 Formulation of the  
 doctrine . . . . . 2347<sup>b</sup>  
 of Gospels, The Synop-  
 tic . . . . . 2344<sup>a</sup>; 1281<sup>b</sup> (Iverach)  
 of Immanuel . . . . . 1457<sup>b</sup> (A. W. Evans)  
 of Jesus Christ . . . . . 1624<sup>a</sup> (Orr)  
 of Johannine Theology 1695<sup>b</sup> (Law)  
 of John, Gospel of . . . . . 1720<sup>a</sup> (Iverach)  
 of Kenosis . . . . . 1792<sup>a</sup> (Easton)  
 Method of the article . . . . . 2338<sup>a</sup>  
 of Only Begotten . . . . . 2196<sup>a</sup> (Rees)  
 Other Epistles besides  
 Hebrews . . . . . 2342<sup>a</sup>  
 of Salvation . . . . . 2665<sup>a</sup> (Easton)  
 Teaching of Epistle to  
 Hebrews . . . . . 2341<sup>a</sup>  
 Deity . . . . . 2342<sup>a</sup>  
 Humanity . . . . . 2342<sup>a</sup>  
 Teaching of Jesus . . . . . 2344<sup>b</sup>  
 Johannine Jesus, the . . . . . 2344<sup>b</sup>  
 Synoptic Jesus, the . . . . . 2345<sup>b</sup>  
 Teaching of John . . . . . 2342<sup>a</sup>  
 Epistles . . . . . 2342<sup>a</sup>  
 Gospel, the . . . . . 2343<sup>b</sup>  
 Prologue to Fourth  
 Gospel . . . . . 2342<sup>b</sup>  
 Teaching of Paul . . . . . 2338<sup>b</sup>  
 Humanity of Christ 2340<sup>a</sup>  
 Intrinsic Deity . . . . . 2338<sup>b</sup>  
 Other Pauline texts 2340<sup>a</sup>  
 In Phil 2 5-9 . . . . . 2338<sup>b</sup>  
 Two natures presup-  
 posed . . . . . 2347<sup>a</sup>  
 of Word . . . . . 3105<sup>a</sup> (W. L. Walker)  
 Person, Personality . . . . . 2337<sup>a</sup> (W. L. Walker)  
 Biblical usage . . . . . 2337<sup>a</sup>  
 Subconscious, the . . . . . 2337<sup>b</sup>  
 Terms used . . . . . 2337<sup>a</sup>  
 Personality  
 of Person . . . . . 2337<sup>a</sup> (W. L. Walker)  
 Persuade, Persuasion . . . . . 2348<sup>a</sup> (Easton)  
 Peruda (Perida) . . . . . 2323<sup>a</sup>  
 of Pharida . . . . . 2361<sup>a</sup>  
 Perverse . . . . . 2348<sup>a</sup>  
 Peshito  
 of Syriac Versions . . . . . 2883<sup>b</sup> (Nicol)  
 Pestilence . . . . . 2348<sup>a</sup> (Macalister)  
 Pestle . . . . . 2348<sup>b</sup>  
 of Mortar . . . . . 2083<sup>a</sup> (Orr)  
 Peter, Apocalypse of  
 of Apocryphal Gospels 195<sup>a</sup> (Hutchison)  
 Peter, Apocryphal Gospel  
 of . . . . . 197<sup>b</sup> (Hutchison)  
 of Literature, Sub-apos 1896<sup>b</sup> (Cowan)  
 Peter, The First Epistle  
 of . . . . . 2351<sup>b</sup> (Moorehead)



- Peter, The First Epistle of—*continued*  
 Address, the . . . . . 2352<sup>a</sup>  
 Analysis . . . . . 2355<sup>a</sup>  
 Canonicity of . . . . . 2352<sup>a</sup>  
 Characteristics of . . . . . 2353<sup>b</sup>  
 Christian brotherhood 2354<sup>b</sup>  
 Design . . . . . 2352<sup>b</sup>  
 Inheritance . . . . . 2354<sup>a</sup>  
 cf Literature, Sub-  
   apostolic . . . . . 1896<sup>b</sup> (Cowan)  
 Persecution . . . . . 2353<sup>a</sup>  
 Place and time . . . . . 2352<sup>b</sup>  
 cf Simon Magus . . . . . 2796<sup>b</sup> (Rutherford)  
 Spirits in Prison . . . . . 2354<sup>b</sup>  
   cf Prison, Spirits in. 2456<sup>b</sup> (Orr)
- Peter, The Second Epistle  
 of . . . . . 2355<sup>a</sup> (Moorehead)  
 Claim to Petrine au-  
   thorship . . . . . 2356<sup>a</sup>  
 Compared with Jude . . . . . 1769<sup>a</sup> (Moorehead)  
 Doctrinal teachings . . . . . 2356<sup>b</sup>  
 External evidence . . . . . 2355<sup>a</sup>  
 Internal evidence . . . . . 2355<sup>b</sup>  
 cf Peter (Simon) . . . . . 2348<sup>b</sup> (Gray)  
 Quoted by Jude . . . . . 2356<sup>b</sup>  
   cf Jude, Epistle of . . . . . 1767<sup>b</sup> (Moorehead)  
 Saving knowledge . . . . . 2357<sup>a</sup>  
 cf Simon Magus . . . . . 2796<sup>b</sup> (Rutherford)  
 Style and diction . . . . . 2355<sup>b</sup>  
 cf Supply . . . . . 2871<sup>b</sup> (Easton)  
 Three worlds, the . . . . . 2357<sup>b</sup>
- Peter, Simon . . . . . 2348<sup>b</sup> (Gray)  
 Character of . . . . . 2349<sup>b</sup>  
 Confession of . . . . . 1648<sup>b</sup> (Orr)  
 Denial of Jesus . . . . . 1661<sup>a</sup> (Orr)  
 Dispute with Simon  
   Magus . . . . . 2796<sup>b</sup> (Rutherford)  
 In Galatians . . . . . 1160<sup>b</sup> (G. G. Findlay)  
 On inspiration . . . . . 1474<sup>b</sup> (Warfield)  
 cf Joseph of Arima-  
   thaea . . . . . 1741<sup>b</sup> (Kerr)  
 Keys given to . . . . . 1794<sup>a</sup> (Carver)  
 cf Law in NT . . . . . 1847<sup>b</sup> (M'Caig)  
 Life story of . . . . . 2349<sup>a</sup>  
 cf Mark, Gospel of . . . . . 1989<sup>b</sup> (Farmer)  
 Name and first ap-  
   pearance . . . . . 2348<sup>b</sup>  
 cf Peter, First Epistle  
   of . . . . . 2351<sup>b</sup> (Moorehead)  
 cf Peter, Second Epis-  
   tle of . . . . . 2355<sup>a</sup> (Moorehead)  
 Restoration of . . . . . 1666<sup>a</sup> (Orr)  
 Theology of . . . . . 2350<sup>b</sup>  
 Writings of . . . . . 2350<sup>a</sup>
- Pethahiah . . . . . 2358<sup>a</sup>  
 cf Patheus . . . . . 2263<sup>a</sup>
- Pethor . . . . . 2358<sup>a</sup> (Pinches)
- Pethuel . . . . . 2358<sup>a</sup>
- Petition . . . . . 2358<sup>a</sup> (Easton)
- Petra  
 cf Nabataeans . . . . . 2107<sup>b</sup> (Angus)  
 cf Sela . . . . . 2713<sup>b</sup> (Ewing)
- Peulthai, Peullethai . . . . . 2358<sup>b</sup>
- Phaath Moab . . . . . 2358<sup>b</sup> (Angus)  
 cf Pahath-moab . . . . . 2207<sup>a</sup> (Wallace)
- Phacareth . . . . . 2358<sup>b</sup>  
 cf Sabie . . . . . 2636<sup>a</sup>
- Phainon (Punon) . . . . . 2506<sup>a</sup>
- Phaisur . . . . . 2358<sup>b</sup>
- Phaldeus . . . . . 2358<sup>b</sup>
- Phaleas . . . . . 2358<sup>b</sup>
- Phalec . . . . . 2358<sup>b</sup>
- Phalias . . . . . 2358<sup>b</sup>
- Phallu  
 cf Pallu . . . . . 2235<sup>a</sup>
- Phalti  
 cf Palti . . . . . 2236<sup>b</sup>
- Phaltiel . . . . . 2358<sup>b</sup>  
 cf Paltiel (Psaltiel) . . . . . 2236<sup>b</sup>
- Phanuel . . . . . 2358<sup>b</sup>  
 cf Peniel . . . . . 2298<sup>a</sup> (Ewing)
- Pharakim, Pharacim . . . . . 2359<sup>a</sup>
- Pharaoh . . . . . 2359<sup>a</sup> (Kyle)  
 cf Slave, Slavery . . . . . 2815<sup>a</sup> (Raffety)  
 cf Tahpenes . . . . . 2903<sup>a</sup>  
 Use of name in Bible . . . . . 2359<sup>a</sup>  
 Use of name in Egypt . . . . . 2359<sup>a</sup>
- Pharaoh Hophra . . . . . 2359<sup>a</sup> (Nicol)  
 Alliance with Zedekiah 2359<sup>b</sup>  
 Palace of . . . . . 2359<sup>b</sup>  
 Reception of Jeremiah  
   and Jews . . . . . 2359<sup>b</sup>
- Pharaoh-necoh . . . . . 2360<sup>a</sup> (Nicol)  
 Battle of Carchemish . . . . . 2360<sup>a</sup>  
 Battle of Megiddo . . . . . 2360<sup>a</sup>  
 cf Jehoiakim . . . . . 1579<sup>a</sup> (Genung)  
 Revolt of . . . . . 572<sup>a</sup> (Nicol)  
 cf Ships and Boats . . . . . 2775<sup>b</sup> (Nicol)
- Pharaoh's Daughter . . . . . 2360<sup>b</sup> (Kyle)
- Pharathon . . . . . 2360<sup>b</sup> (Ewing)  
 cf Pirathon . . . . . 2400<sup>a</sup> (Ewing)
- Phares . . . . . 2360<sup>b</sup>
- Pharez, Perez . . . . . 2320<sup>b</sup>; 2361<sup>a</sup>  
 cf Phoros . . . . . 2361<sup>a</sup>; 2392<sup>a</sup>
- Pharida (Pharira) . . . . . 2361<sup>a</sup>
- Pharisees . . . . . 2361<sup>a</sup> (J. E. H. Thomson);  
   458<sup>a</sup> (Dosker)  
 cf Asmoneans . . . . . 283<sup>a</sup> (Dosker)  
 Attitude toward "peo-  
   ple of the land" . . . . . 2364<sup>a</sup>  
 Doctrines of . . . . . 2362<sup>b</sup>  
 cf Hasidæans . . . . . 1342<sup>b</sup> (Hutchison)  
 History of . . . . . 2361<sup>b</sup>  
 Jesus and the . . . . . 2365<sup>a</sup>  
 cf Jesus Christ . . . . . 1624<sup>a</sup> (Orr)  
 cf Josephus Flavius . . . . . 1742<sup>a</sup> (Wenley)  
 Later history of . . . . . 2362<sup>a</sup>  
 Name and character . . . . . 2361<sup>a</sup>  
 NT references . . . . . 2364<sup>b</sup>  
 In NT times . . . . . 2362<sup>a</sup>  
 Organization . . . . . 2363<sup>b</sup>  
 Origin of . . . . . 2361<sup>b</sup>  
 cf Pauline Theology . . . . . 2289<sup>a</sup> (Easton)  
 cf Phylactery . . . . . 2392<sup>b</sup> (Mack)

- Pharisees—*continued*  
 Regulations.....2364<sup>a</sup>  
 of Sadducees.....2658<sup>b</sup> (J. E. H. Thomson)  
 Text of Scripture.....2363<sup>b</sup>  
 Traditions.....2363<sup>a</sup>
- Pharosh  
 cf Parosh.....2248<sup>b</sup>
- Pharpar.....2365<sup>b</sup>  
 cf Amana.....113<sup>a</sup> (C. H. Thomson)
- Pharzites  
 cf Perez.....2320<sup>b</sup> (Wallace)
- Phaseah.....2365<sup>b</sup>  
 cf Paseah.....2255<sup>a</sup>
- Phaselis.....2365<sup>b</sup> (Banks)  
 cf Lycia.....1943<sup>a</sup> (Banks)
- Phasiron.....2365<sup>b</sup>
- Phassaros  
 cf Phassurus.....2365<sup>b</sup>
- Phassurus.....2365<sup>b</sup>  
 cf Phaisur.....2358<sup>b</sup>
- Phebe  
 cf Phoebe.....2386<sup>a</sup> (S. F. Hunter)
- Phenice  
 cf Phoenicia.....2386<sup>a</sup> (Porter)  
 cf Phoenix.....2391<sup>a</sup> (Calder)
- Phenicia  
 cf Phoenicia.....2386<sup>a</sup> (Porter)
- Pheresites.....2366<sup>a</sup>
- Pherezite.....2366<sup>a</sup>
- Phi-beseth  
 cf Pi-beseth.....2394<sup>b</sup> (Kyle)
- Phicol, Phichol.....2366<sup>a</sup>
- Philadelphia.....2366<sup>a</sup> (Banks)
- Philarches  
 cf Phylarch.....2393<sup>b</sup>
- Philemon.....2366<sup>b</sup> (C. S. Lewis)  
 cf Philemon, Epistle to 2366<sup>b</sup> (C. S. Lewis)  
 cf Philippians, Epistle  
 to.....2372<sup>a</sup> (Hayes)
- Philemon, Epistle to.....2366<sup>b</sup> (C. S. Lewis)  
 Authenticity.....2367<sup>a</sup>  
 Contents.....2367<sup>a</sup>  
 cf Philemon.....2366<sup>b</sup> (C. S. Lewis)  
 cf Philippians, Epistle  
 to.....2372<sup>a</sup> (Hayes)  
 Place of writing.....2366<sup>b</sup>
- Philetus.....2367<sup>b</sup> (Rutherford)  
 cf Hymenaeus.....1444<sup>a</sup> (Rutherford)
- Philip, the Apostle.....2368<sup>a</sup> (Kerr)  
 cf Andrew.....131<sup>a</sup> (Kerr)  
 cf Apocryphal Gospels 195<sup>a</sup> (Hutchison)  
 Apocryphal references. 2368<sup>a</sup>  
 Character.....2368<sup>b</sup>  
 cf Joseph of Arima-  
 thaea.....1741<sup>b</sup> (Kerr)  
 NT references.....2368<sup>a</sup>
- Philip, the Evangelist.....2368<sup>b</sup> (S. F. Hunter)  
 cf Ethiopian Eunuch. 1034<sup>b</sup> (Kerr)  
 cf Simon Magus.....2795<sup>b</sup> (Rutherford)
- Philip (general).....2367<sup>b</sup> (Hutchison)  
 cf Perseus.....2328<sup>b</sup> (Angus)
- Philip, The Gospel of  
 cf Apocryphal Gospels 195<sup>a</sup> (Hutchison)  
 cf Philip, the Apostle. 2368<sup>a</sup> (Kerr)
- Philip of Macedon.....2367<sup>b</sup> (Hutchison)  
 cf Macedonia.....1957<sup>a</sup> (Tod)
- Philip, the Tetrarch  
 cf Herod.....1378<sup>b</sup> (Dosker)
- Philippi.....2369<sup>a</sup> (Tod)  
 Church in.....2371<sup>b</sup>  
 History.....2369<sup>a</sup>  
 cf Lydia.....1943<sup>b</sup> (S. F. Hunter)  
 cf Macedonia.....1957<sup>a</sup> (Tod)  
 Name and position...2369<sup>a</sup>  
 cf Neapolis.....2126<sup>a</sup> (Tod)  
 Paul's visits to.....2369<sup>b</sup>  
 cf Philippians, Epistle  
 to.....2372<sup>a</sup> (Hayes)  
 cf Proseuche.....2469<sup>b</sup>  
 Roman elements in...2370<sup>b</sup>  
 cf Samothrace.....2675<sup>a</sup> (Kinsella)
- Philippians, The Epistle  
 to.....2372<sup>a</sup> (Hayes)  
 Characteristics of the  
 church.....2372<sup>a</sup>  
 Contents.....2375<sup>a</sup>  
 Date, place and occa-  
 sion.....2374<sup>b</sup>  
 cf Kenosis.....1792<sup>a</sup> (Easton)  
 Love and joy.....2373<sup>b</sup>  
 Nature of the Epistle. 2372<sup>b</sup>  
 Paul and the church. 2372<sup>a</sup>  
 cf Philemon, Epistle to 2366<sup>b</sup> (C. S. Lewis)  
 cf Philippi.....2369<sup>a</sup> (Tod)  
 cf Praetorian Guard...2427<sup>b</sup> (Rutherford)  
 cf Proseuche.....2469<sup>b</sup>  
 Theological impor-  
 tance.....2374<sup>a</sup>
- Philistia.....2376<sup>a</sup> (Porter)  
 cf Philistines.....2376<sup>b</sup> (Conder)
- Philistim  
 cf Philistines.....2376<sup>b</sup> (Conder)
- Philistines.....2376<sup>b</sup> (Conder)  
 cf Ashtaroth.....270<sup>a</sup> (Ewing)  
 Cretan theory.....2378<sup>b</sup>  
 David's guards.....2379<sup>a</sup>  
 Egyptian and Assyr-  
 ian references.....2378<sup>b</sup>  
 Government.....2377<sup>a</sup>  
 History.....2377<sup>b</sup>  
 cf Hittites.....1395<sup>b</sup> (Conder)  
 cf Judah.....1759<sup>a</sup> (Weir)  
 cf Lords of the Philis-  
 tines.....1929<sup>b</sup>  
 Monumental remains. 2378<sup>a</sup>  
 Names mentioned...2377<sup>a</sup>  
 cf Palestine, Recent  
 Exploration.....2233<sup>b</sup> (Cobern)  
 cf Philistia.....2376<sup>a</sup> (Porter)  
 Race and origin.....2376<sup>b</sup>  
 Religion of.....2377<sup>a</sup>  
 cf Samuel.....2677<sup>a</sup> (Geden)  
 cf Saul.....2698<sup>a</sup> (Weir)

- Philistines, Lords of the. 1929<sup>b</sup>  
 cf Philistia. . . . . 2376<sup>a</sup> (Porter)
- Philistines, Sea of the  
 cf Mediterranean Sea. 2026<sup>b</sup> (Heidel)
- Philo Judaeus. . . . . 2380<sup>a</sup> (Wenley); 685<sup>a</sup>  
 (Oko); 998<sup>b</sup> (J. E. H. Thomson)
- Changes and new  
 problems. . . . . 2380<sup>a</sup>
- cf Logos. . . . . 1913<sup>b</sup> (Alexander)
- cf Mediation, Media-  
 tor. . . . . 2021<sup>a</sup> (Edwards)
- cf Paraclete. . . . . 2245<sup>a</sup> (Mullins)
- Period. . . . . 2380<sup>a</sup>
- cf Philosophy. . . . . 2383<sup>a</sup> (Rees)
- Task. . . . . 2380<sup>b</sup>
- Themes treated. . . . . 2381<sup>b</sup>
- cf Wisdom. . . . . 3092<sup>a</sup> (Easton)
- Philologus. . . . . 2383<sup>a</sup> (S. F. Hunter)
- Philometor  
 cf Ptolemy. . . . . 2499<sup>b</sup> (Angus)
- Philosophy. . . . . 2383<sup>a</sup> (Rees)
- cf Covenant (in OT). 727<sup>a</sup> (Berry)
- Definition and scope. 2383<sup>a</sup>
- cf God. . . . . 1250<sup>a</sup> (Rees)
- Greek. . . . . 2384<sup>a</sup>
- cf Logos. . . . . 1911<sup>b</sup> (Alexander)
- NT references. . . . . 2385<sup>a</sup>
- OT and Judaism. . . . . 2384<sup>b</sup>
- cf Persian Religion,  
 Ancient. . . . . 2331<sup>b</sup> (Tisdall)
- cf Philo Judaeus. . . . . 2380<sup>a</sup> (Wenley)
- cf Righteousness. . . . . 2591<sup>a</sup> (McConnell)
- cf Stoics. . . . . 2854<sup>b</sup> (Rees)
- cf Truth. . . . . 3025<sup>a</sup> (Carver)
- cf Wisdom. . . . . 3089<sup>a</sup> (Easton)
- Phinees. . . . . 2385<sup>b</sup> (Angus)
- cf Phineo. . . . . 2385<sup>b</sup>
- Phinehas. . . . . 2385<sup>b</sup> (Wallace)
- cf Hophni and Phine-  
 has. . . . . 1421<sup>a</sup> (Wallace)
- cf Putiel. . . . . 2511<sup>a</sup>
- Phineo. . . . . 2385<sup>b</sup>
- cf Paseah. . . . . 2255<sup>a</sup>
- cf Phaseah. . . . . 2365<sup>b</sup>
- cf Phinees. . . . . 2385<sup>b</sup> (Angus)
- Phinon (Punon). . . . . 2506<sup>a</sup>
- Phlegon. . . . . 2385<sup>b</sup>
- Phoebe. . . . . 2386<sup>a</sup> (S. F. Hunter)
- Phoenix  
 cf Phoenix. . . . . 2391<sup>a</sup> (Calder)
- Phoenicia, Phoenicians. 2386<sup>a</sup> (Porter)
- cf Alphabet. . . . . 103<sup>b</sup> (Richardson)
- Arts and crafts. . . . . 2388<sup>a</sup>
- cf Ashtoreth. . . . . 270<sup>b</sup> (Sayce)
- cf Coins. . . . . 673<sup>a</sup> (Porter)
- Colonies. . . . . 2387<sup>a</sup>
- Commerce and trade. 2388<sup>b</sup>
- cf Glass. . . . . 1233<sup>a</sup> (Porter)
- cf Gold. . . . . 1274<sup>a</sup> (Patch)
- History. . . . . 2390<sup>a</sup>
- cf Ladder of Tyre. . . . . 1821<sup>a</sup> (Porter)
- Phoenicia, Phoenicians—*continued*
- Land. . . . . 2386<sup>a</sup>
- Language and culture. 2389<sup>a</sup>
- People. . . . . 2387<sup>b</sup>
- cf Ptolemais. . . . . 2499<sup>a</sup>
- Religion. . . . . 2389<sup>a</sup>
- cf Ships and Boats. . . . . 2775<sup>b</sup> (Nicol)
- cf Sidon (place). . . . . 2785<sup>a</sup> (Porter)
- cf Syria. . . . . 2881<sup>a</sup> (Christie)
- cf Tyre. . . . . 3030<sup>b</sup> (Porter)
- Phoenix. . . . . 2391<sup>a</sup> (Calder)
- cf Crete. . . . . 744<sup>b</sup> (Calder)
- Harbor in Crete. . . . . 2391<sup>a</sup>
- cf Literature, Sub-apos 1897<sup>a</sup> (Cowan)
- Location. . . . . 2391<sup>b</sup>
- cf Northeast. . . . . 2155<sup>b</sup> (Day)
- cf Paul, the Apostle. . . . . 2286<sup>b</sup> (A. T. Robertson)
- Reference in Acts 27. 2391<sup>b</sup>
- cf Salmone. . . . . 2663<sup>b</sup>
- Phoros. . . . . 2392<sup>a</sup>
- cf Pharez. . . . . 2361<sup>a</sup>
- Phururai. . . . . 2392<sup>a</sup>
- cf Purim. . . . . 2506<sup>b</sup> (Mack)
- Phrygia. . . . . 2392<sup>a</sup> (Banks)
- cf Pacatiana. . . . . 2206<sup>a</sup>
- Phrygian Immigrations  
 to Asia Minor. . . . . 274<sup>b</sup> (Calder)
- Phurah  
 cf Purah. . . . . 2506<sup>a</sup>
- Phurim (Phururai). . . . . 2392<sup>a</sup>
- Phut  
 cf Put. . . . . 2510<sup>a</sup> (Pinches)
- Phuvah  
 cf Puah. . . . . 2501<sup>a</sup> (E. D. Isaacs)
- Phygelus (Phygelus). . . . . 2392<sup>b</sup> (Rutherford)
- cf Hermogenes. . . . . 1377<sup>b</sup> (Rutherford)
- cf Persecution. . . . . 2323<sup>b</sup> (Rutherford)
- Phylactery. . . . . 2392<sup>b</sup> (Mack)
- Bible references. . . . . 2392<sup>b</sup>
- Description. . . . . 2393<sup>a</sup>
- cf Fringes. . . . . 1146<sup>b</sup> (E. D. Isaacs)
- cf Frontlets. . . . . 1147<sup>a</sup>
- Interpretation. . . . . 2393<sup>b</sup>
- cf Libraries. . . . . 1886<sup>a</sup> (Richardson)
- cf Pharisees. . . . . 2361<sup>a</sup> (J. E. H. Thomson)
- Phylarch. . . . . 2393<sup>b</sup>
- Phylarches  
 cf Phylarch. . . . . 2393<sup>b</sup>
- Physician. . . . . 2393<sup>b</sup> (Macalister)
- Ancient references. . . . . 2393<sup>b</sup>
- NT references. . . . . 2394<sup>a</sup>
- Priest as. . . . . 2394<sup>a</sup>
- Physiography. . . . . 314<sup>b</sup>
- Pi-beseth. . . . . 2394<sup>b</sup> (Kyle)
- Picture. . . . . 2394<sup>b</sup> (T. Lewis)
- Piece. . . . . 2394<sup>b</sup> (T. Lewis)
- Piece of Gold. . . . . 2394<sup>b</sup>
- cf Money. . . . . 2076<sup>a</sup> (Porter)
- Piece of Money. . . . . 2394<sup>b</sup>
- Piece of Silver. . . . . 2395<sup>a</sup>
- cf Money. . . . . 2076<sup>a</sup> (Porter)
- cf Silverling. . . . . 2793<sup>a</sup>

- Piety . . . . . 2395<sup>a</sup>  
 Pigeon . . . . . 2395<sup>a</sup> (Stratton-Porter)  
   Characteristics . . . . . 2395<sup>a</sup>  
   of Dove . . . . . 871<sup>a</sup> (Stratton-Porter)  
   of Food . . . . . 1124<sup>a</sup> (Eager)  
   References to . . . . . 2395<sup>b</sup>  
 Pi-hahiroth . . . . . 2396<sup>a</sup> (Kyle)  
   of Goshen . . . . . 1280<sup>a</sup> (Conder)  
 Pilate, Acts of  
   of Apocryphal Gospels. 195<sup>a</sup> (Hutchison)  
   of Pilate, Pontius . . . . . 2396<sup>a</sup> (J. M. Wilson)  
 Pilate, Pontius . . . . . 2396<sup>a</sup> (J. M. Wilson)  
   of Apocryphal Gospels. 195<sup>a</sup> (Hutchison)  
   Character . . . . . 2398<sup>a</sup>  
   of Gabbatha . . . . . 1150<sup>b</sup> (Masterman)  
   of Governor . . . . . 1289<sup>b</sup> (Heidel)  
   of Jerusalem . . . . . 1611<sup>b</sup> (Masterman)  
   Jesus and . . . . . 2397<sup>a</sup>  
   of Jesus Christ (Trial  
     before Pilate) . . . . . 1661<sup>a</sup> (Orr); 1672<sup>a</sup> (Mac-  
       laren)  
   Name and office . . . . . 2396<sup>a</sup>  
   of Procurator . . . . . 2457<sup>b</sup> (Allen)  
   Procuratorship of . . . . . 2396<sup>b</sup>  
   of Province . . . . . 2485<sup>b</sup> (Allen)  
   Traditions . . . . . 2397<sup>b</sup>  
 Pildash . . . . . 2398<sup>b</sup>  
 Pile . . . . . 2398<sup>b</sup>  
   of Topheth . . . . . 2999<sup>b</sup> (Masterman)  
 Pileha  
   of Pilha . . . . . 2398<sup>b</sup>  
 Pilgrim, Pilgrimage . . . . . 2398<sup>b</sup>  
 Pilha . . . . . 2398<sup>b</sup>  
 Pill  
   of Peel . . . . . 2295<sup>a</sup> (Easton)  
 Pillar . . . . . 2398<sup>b</sup> (Orr)  
   of Gezer . . . . . 1223<sup>b</sup> (Masterman)  
   of High Place . . . . . 1390<sup>a</sup> (Easton)  
   of Image . . . . . 1450<sup>a</sup> (Edwards)  
   of Jachin and Boaz . . . . . 1547<sup>b</sup> (Caldecott)  
   of Obelisk . . . . . 2177<sup>b</sup>  
 Pillar of Cloud and Fire. 2399<sup>a</sup> (Orr); 670<sup>b</sup> (Joy)  
 Pillar, Plain of the . . . . . 2407<sup>b</sup> (Ewing)  
 Pillar of Salt  
   of Lot . . . . . 1929<sup>b</sup> (Boyd)  
   of Slime . . . . . 2817<sup>b</sup> (Day)  
 Pillars of the Earth  
   of Astronomy . . . . . 300<sup>b</sup> (Maunder)  
 Pillow  
   of Bolster . . . . . 494<sup>b</sup> (Eager)  
   of Cushion . . . . . 769<sup>a</sup> (Downer)  
 Pilot  
   of Ships and Boats . . . . . 2774<sup>a</sup> (Nicol)  
 Piltai . . . . . 2399<sup>a</sup>  
 Pin . . . . . 2399<sup>a</sup> (N. Isaacs)  
   of Crisping Pins . . . . . 748<sup>b</sup>  
   of Stake . . . . . 2847<sup>b</sup>  
 Pine  
   of Pining Sickness . . . . . 2399<sup>b</sup> (Macalister)  
 Pine Tree . . . . . 2399<sup>a</sup> (Masterman)  
   of Oil Tree . . . . . 2183<sup>a</sup> (Masterman)  
 Pining Sickness . . . . . 2399<sup>b</sup> (Macalister)  
 Pinion . . . . . 2400<sup>a</sup> (Luering)  
 Pinnacle . . . . . 2400<sup>a</sup>  
 Pinon . . . . . 2400<sup>a</sup>  
 Pipe  
   of Candlestick . . . . . 552<sup>b</sup> (Eager)  
   of Lamp . . . . . 1825<sup>a</sup> (Porter)  
   of Music . . . . . 2094<sup>b</sup> (Millar)  
 Pira . . . . . 2400<sup>a</sup>  
   of Caphira . . . . . 568<sup>a</sup>; 602<sup>b</sup>  
 Piram . . . . . 2400<sup>a</sup>  
 Pirathon, Pirathonite . . . . . 2400<sup>a</sup> (Ewing)  
   of Pharathon . . . . . 2360<sup>b</sup> (Ewing)  
 Pisgah . . . . . 2400<sup>a</sup> (Ewing)  
 Pishon, Pison . . . . . 2400<sup>b</sup>  
 Pisidia . . . . . 2400<sup>b</sup> (Calder)  
   Paul in . . . . . 2401<sup>a</sup>  
   Situation and history . . . . . 2400<sup>b</sup>  
 Pison  
   of Pishon . . . . . 2400<sup>b</sup>  
 Pispa, Pispah . . . . . 2401<sup>b</sup>  
 Pit . . . . . 2401<sup>b</sup> (T. Lewis)  
   of Abyss . . . . . 26<sup>b</sup> (T. Lewis)  
   of Hell . . . . . 1371<sup>a</sup> (Orr)  
   of Water . . . . . 3074<sup>a</sup> (Joy)  
   of Well . . . . . 3081<sup>a</sup> (Day)  
 Pitch . . . . . 2401<sup>b</sup> (Easton)  
   of Slime . . . . . 2817<sup>b</sup> (Day)  
 Pitcher . . . . . 2401<sup>b</sup>  
 Pithom . . . . . 2401<sup>b</sup> (Conder)  
   of Eiham . . . . . 1012<sup>b</sup> (Conder)  
   of Exodus, The . . . . . 1052<sup>a</sup> (Conder)  
   of Goshen . . . . . 1280<sup>a</sup> (Conder)  
   Name and meaning . . . . . 2401<sup>b</sup>  
   of Raamses . . . . . 2520<sup>a</sup> (Conder)  
   Situation . . . . . 2402<sup>a</sup>  
   of Store-cities . . . . . 2863<sup>a</sup>  
   of Succoth . . . . . 2869<sup>a</sup> (Conder)  
   of Zoan . . . . . 3153<sup>a</sup> (Conder)  
 Pithon . . . . . 2402<sup>a</sup>  
 Pitiful . . . . . 2402<sup>a</sup> (W. L. Walker)  
 Pity . . . . . 2402<sup>b</sup> (W. L. Walker)  
   of Compassion . . . . . 695<sup>a</sup> (W. L. Walker)  
   of Mercy . . . . . 2035<sup>b</sup> (W. L. Walker)  
 Place . . . . . 2402<sup>b</sup>  
 Place, Broad, High  
   of City . . . . . 662<sup>a</sup> (A. C. Dickie)  
   of High Place . . . . . 1390<sup>a</sup> (Easton)  
   of Open Place . . . . . 2196<sup>b</sup> (Easton)  
 Plague . . . . . 2402<sup>b</sup> (Macalister); 911<sup>b</sup>  
   (Petrie)  
   of Fly, Flies . . . . . 1120<sup>b</sup> (Day)  
 Plagues of Egypt . . . . . 2403<sup>a</sup> (Kyle)  
   Boils, hail, locusts . . . . . 2405<sup>b</sup>  
   of Burning Bush . . . . . 532<sup>b</sup> (Kyle)  
   of Firstborn, Firstling . 1113<sup>b</sup> (T. Lewis)  
   Frogs, lice, flies . . . . . 2404<sup>b</sup>  
   Miraculous features . . . . . 2405<sup>b</sup>  
   Moral purpose . . . . . 2406<sup>a</sup>  
   Murrain of cattle . . . . . 2405<sup>a</sup>  
   Natural phenomena . . . . . 2403<sup>b</sup>  
   Water turned to blood . 2404<sup>a</sup>  
   Words used . . . . . 2403<sup>b</sup>

- Plain . . . . . 2406<sup>b</sup> (Day)  
 cf Abel-cheramim . . . . . 5<sup>b</sup>  
 cf Arabah . . . . . 211<sup>b</sup> (Wright)  
 cf Ciccar . . . . . 655<sup>b</sup>  
 cf Circle . . . . . 656<sup>b</sup>  
 cf Meadow . . . . . 2013<sup>a</sup> (Day)  
 cf Natural Features . . . . . 2122<sup>a</sup> (Day)  
 Plain, Cities of the . . . . . 660<sup>a</sup> (Wright)  
 Plain of Moab . . . . . 2407<sup>a</sup>  
 cf Moab . . . . . 2069<sup>b</sup> (Porter)  
 Plain of the Pillar . . . . . 2407<sup>b</sup> (Ewing)  
 cf Meonenim, Oak of . . . . . 2033<sup>b</sup>  
 Plain, Plainly . . . . . 2407  
 Plain of the Vineyards  
 cf Abel-cheramim . . . . . 5<sup>b</sup>  
 Plaster  
 cf Plaster . . . . . 2408<sup>a</sup>  
 Plaiting . . . . . 2407<sup>b</sup>  
 cf Braided, Braiding . . . . . 513<sup>b</sup>  
 Plane  
 cf Tools . . . . . 2998<sup>b</sup> (Easton)  
 Plane Tree . . . . . 2407<sup>b</sup>; 507<sup>b</sup> (Masterman)  
 Planets  
 cf Astrology . . . . . 295<sup>b</sup> (Maunder)  
 Plank . . . . . 2407<sup>b</sup>  
 cf Ships and Boats . . . . . 2774<sup>a</sup> (Nicol)  
 Plant, Plants  
 cf Botany . . . . . 505<sup>a</sup> (Masterman)  
 Plaster . . . . . 2407<sup>b</sup> (Patch); 2408<sup>a</sup>  
 Plastering  
 cf Crafts . . . . . 734<sup>a</sup> (Patch)  
 Plate . . . . . 2408<sup>a</sup> (Betteridge)  
 Plato . . . . . 1017<sup>b</sup> (Alexander)  
 cf Logos . . . . . 1912<sup>a</sup> (Alexander)  
 Platter . . . . . 2408<sup>a</sup> (Pollard)  
 Play  
 cf Games . . . . . 1168<sup>b</sup> (Smith)  
 Plead, Pleadings . . . . . 2408<sup>a</sup> (Easton)  
 Pleasure . . . . . 2408<sup>b</sup> (W. L. Walker)  
 Pledge . . . . . 2408<sup>b</sup> (Easton)  
 cf Earnest . . . . . 886<sup>b</sup> (Schenk)  
 cf Surety . . . . . 2872<sup>a</sup> (Reeve)  
 Pleiades  
 cf Astrology . . . . . 295<sup>b</sup> (Maunder)  
 cf Astronomy . . . . . 311<sup>b</sup> (Maunder)  
 cf Influences . . . . . 1468<sup>a</sup> (W. L. Walker)  
 Pleroma  
 cf Fulness . . . . . 1148<sup>b</sup> (Rutherford)  
 Pliny . . . . . 1000<sup>a</sup> (J. E. H. Thomson)  
 cf Persecution . . . . . 2326<sup>a</sup> (Rutherford)  
 Plow . . . . . 2409<sup>a</sup> (Patch)  
 Figurative use . . . . . 2409<sup>b</sup>  
 Form of . . . . . 2409<sup>a</sup>  
 cf Furrow . . . . . 1150<sup>a</sup> (Patch)  
 Words for . . . . . 2409<sup>b</sup>  
 Pluck Asunder . . . . . 316<sup>b</sup> (S. F. Hunter)  
 Plucking Off the Hair  
 cf Hair . . . . . 1320<sup>a</sup> (Luring)  
 cf Punishments . . . . . 2504<sup>b</sup> (Hirsch)  
 Plumb-line, Plummet  
 cf Tools . . . . . 2998<sup>b</sup> (Easton)  
 Pochereth-hazzebaim . . . . . 2410<sup>a</sup>  
 cf Phacareth . . . . . 2358<sup>b</sup>  
 Poet . . . . . 2410<sup>a</sup> (Schenk)  
 Poetry, Hebrew . . . . . 2410<sup>a</sup> (T. W. Davies)  
 Definition . . . . . 2410<sup>a</sup>  
 cf Divination . . . . . 860<sup>a</sup> (T. W. Davies)  
 Forms . . . . . 2411<sup>a</sup>  
 Internal characteristics . . . . . 2413<sup>b</sup>  
 Neglect of . . . . . 2410<sup>b</sup>  
 Parallelism . . . . . 2411<sup>a</sup>  
 Poetical writings of  
 OT . . . . . 2414<sup>a</sup>  
 cf Poetry, NT . . . . . 2414<sup>b</sup> (Schenk)  
 cf Psalms, Book of . . . . . 2491<sup>b</sup> (Sampey)  
 Poetry, NT . . . . . 2414<sup>b</sup> (Schenk)  
 Examples of . . . . . 2414<sup>b</sup>  
 cf Faithful Sayings . . . . . 1091<sup>a</sup> (Rutherford)  
 Paul's use of . . . . . 2414<sup>b</sup>  
 cf Poetry, Hebrew . . . . . 2410<sup>a</sup> (T. W. Davies)  
 cf Quotations, NT . . . . . 2519<sup>b</sup> (Sweet)  
 Points . . . . . 2415<sup>a</sup> (M. O. Evans)  
 cf Prayers of Jesus . . . . . 2431<sup>b</sup> (Bevan)  
 cf Temptation of  
 Christ . . . . . 2943<sup>a</sup> (Anderson)  
 Poison . . . . . 2415<sup>a</sup> (Macalister)  
 Pole . . . . . 2415<sup>b</sup>  
 Policy . . . . . 2415<sup>b</sup>  
 Polished  
 cf Corner-stone . . . . . 721<sup>b</sup> (Mack)  
 Poll . . . . . 2415<sup>b</sup> (Luring)  
 cf Hair . . . . . 1320<sup>a</sup> (Luring)  
 Pollution . . . . . 2416<sup>a</sup>  
 Pollux  
 cf Dioscuri . . . . . 851<sup>a</sup> (Maunder)  
 Polycarp, Epistle of  
 cf Literature, Sub-apos 1900<sup>b</sup> (Cowan)  
 Polygamy . . . . . 2416<sup>a</sup> (Caverno); 1095<sup>a</sup>  
 (Caverno)  
 cf Divorce, NT and OT 865<sup>a</sup> (Caverno); 863<sup>b</sup> (W.  
 W. Davies)  
 cf Eunuch . . . . . 1037<sup>a</sup> (Eager)  
 cf Family . . . . . 1094<sup>b</sup> (Caverno)  
 cf Marriage . . . . . 1998<sup>a</sup> (Eager)  
 Meaning . . . . . 2416<sup>a</sup>  
 Origin . . . . . 2416<sup>a</sup>  
 In the OT . . . . . 2416<sup>b</sup>  
 cf Punishments . . . . . 2506<sup>a</sup> (Hirsch)  
 Weakness of . . . . . 2417<sup>a</sup>  
 cf Woman . . . . . 3100<sup>a</sup> (Pratt)  
 Pomegranate . . . . . 2417<sup>b</sup> (Masterman); 1123<sup>a</sup>  
 (Eager)  
 Pommel . . . . . 2418<sup>a</sup>  
 cf Bowl . . . . . 511<sup>b</sup> (Eager)  
 Pond  
 cf Cistern . . . . . 657<sup>b</sup> (A. C. Dickie)  
 cf Pool . . . . . 2419<sup>b</sup> (Day)  
 Ponder . . . . . 2418<sup>a</sup>  
 Pontius  
 cf Pilate, Pontius . . . . . 2396<sup>a</sup> (J. M. Wilson)  
 Pontus . . . . . 2418<sup>a</sup> (White)  
 cf Archaeology of Asia  
 Minor . . . . . 277<sup>a</sup> (White)

- Pontus—*continued*  
 of Bithynia . . . . . 483<sup>a</sup> (White)  
 Christianity in . . . . . 2419<sup>a</sup>  
 History . . . . . 2418<sup>b</sup>  
 Location . . . . . 2418<sup>a</sup>  
 of Persecution . . . . . 2323<sup>b</sup> (Rutherford)
- Pool, Pond, Reservoir . . . . . 2419<sup>b</sup> (Day)  
 of Cistern . . . . . 657<sup>b</sup> (A. C. Dickie)  
 of Jerusalem . . . . . 1610<sup>b</sup> (Masterman)  
 of Lake . . . . . 1822<sup>a</sup> (Day)  
 of Natural Features . . . . . 2122<sup>a</sup> (Day)  
 of Reed . . . . . 2544<sup>a</sup> (Masterman)  
 of Water . . . . . 3074<sup>a</sup> (Joy)  
 of Well . . . . . 3081<sup>a</sup> (Day)
- Pools of Solomon  
 of Cistern . . . . . 657<sup>b</sup> (A. C. Dickie)  
 of Pool . . . . . 2419<sup>b</sup> (Day)
- Poor . . . . . 2420<sup>a</sup> (W. L. Walker)  
 of Alms . . . . . 101<sup>b</sup> (Eager)  
 NT references . . . . . 2421<sup>a</sup>  
 OT references . . . . . 2420<sup>a</sup>  
 of Poverty . . . . . 2426<sup>b</sup> (W. Evans)  
 of Quiet . . . . . 2515<sup>b</sup> (M. O. Evans)
- Poplar . . . . . 2421<sup>b</sup> (Masterman); 507<sup>b</sup>  
 of Mulberry Trees . . . . . 2093<sup>b</sup> (Masterman)
- Poppaea  
 of Nero . . . . . 2135<sup>b</sup> (Angus)
- Poratha . . . . . 2421<sup>b</sup>
- Porch . . . . . 2421<sup>b</sup>  
 of Porch, Portico, Solomon's . . . . . 2421<sup>b</sup> (Caldecott)  
 of Temple . . . . . 2930<sup>a</sup> (Caldecott; Orr)
- Porch, Portico, Solomon's . . . . . 2421<sup>b</sup> (Caldecott)  
 of Porch . . . . . 2421<sup>b</sup>
- Poreius  
 of Festus, Porcius . . . . . 1107<sup>a</sup> (Kerr)
- Porcupine . . . . . 2421<sup>b</sup> (Day)  
 of Bittern . . . . . 484<sup>a</sup> (Stratton-Porter)  
 of Hedgehog . . . . . 1367<sup>a</sup>  
 of Owl . . . . . 2205<sup>b</sup> (Stratton-Porter)  
 of Serpent . . . . . 2738<sup>a</sup> (Day)
- Porphyry . . . . . 2422<sup>a</sup>; 1000<sup>a</sup> (J. E. H. Thomson)
- Porpoise . . . . . 2422<sup>a</sup>  
 of Badger . . . . . 376<sup>b</sup> (Day)  
 of Sealskin . . . . . 2709<sup>b</sup>
- Port, Porter . . . . . 2422<sup>a</sup> (Easton)  
 of Doorkeeper . . . . . 869<sup>a</sup> (Hovey)
- Portion . . . . . 2422<sup>b</sup> (Easton)
- Posidonius . . . . . 2422<sup>b</sup>
- Possess, Possession . . . . . 2422<sup>b</sup> (Easton)
- Possession, Demoniactal  
 of Demon, Demonic, Demonology . . . . . 827<sup>b</sup> (Sweet)
- Post . . . . . 2423<sup>a</sup> (M. O. Evans)  
 of Guard . . . . . 1307<sup>b</sup> (Nicol)  
 of House . . . . . 1434<sup>b</sup> (A. C. Dickie)
- Pot . . . . . 2423<sup>a</sup> (Betteridge)  
 of Food . . . . . 1121<sup>b</sup> (Eager)  
 of Pan . . . . . 2237<sup>a</sup> (Betteridge)
- Potentate . . . . . 2423<sup>a</sup>
- Potiphar . . . . . 2423<sup>a</sup>
- Poti-phera . . . . . 2423<sup>a</sup> (Kyle)
- Potsherd . . . . . 2423<sup>b</sup>  
 of Harsith . . . . . 1341<sup>a</sup>  
 of Ostraca . . . . . 2202<sup>b</sup> (Goodspeed)  
 of Potter, Pottery . . . . . 2423<sup>b</sup> (Patch)
- Potsherd Gate  
 of Gate, East . . . . . 1176<sup>b</sup> (Caldecott)  
 of Harsith . . . . . 1341<sup>a</sup>
- Pottage  
 of Food . . . . . 1121<sup>b</sup> (Eager)
- Potter, Pottery . . . . . 2423<sup>b</sup> (Patch)  
 Biblical references . . . . . 2425<sup>b</sup>  
 of Crafts . . . . . 734<sup>a</sup> (Patch)  
 of Earthen Vessels . . . . . 887<sup>b</sup> (Patch)  
 Forms . . . . . 2424<sup>a</sup>  
 History of . . . . . 2423<sup>b</sup>  
 Methods . . . . . 2424<sup>a</sup>  
 of Ostraca . . . . . 2202<sup>b</sup> (Goodspeed)  
 of Potsherd . . . . . 2423<sup>b</sup>  
 of Tools . . . . . 2998<sup>b</sup> (Easton)  
 of Vessel . . . . . 3049<sup>a</sup> (Easton)  
 of Wheel . . . . . 3082<sup>b</sup> (Easton)
- Potters' Field  
 of Akeldama . . . . . 89<sup>a</sup> (Masterman)
- Pound . . . . . 2426<sup>b</sup> (Porter)  
 of Maneh . . . . . 1981<sup>a</sup> (Porter)  
 of Wedge of Gold . . . . . 3078<sup>b</sup> (Porter)  
 of Weights and Measures . . . . . 3079<sup>a</sup> (Porter)
- Poverty . . . . . 2426<sup>b</sup> (W. Evans)  
 Degrees and causes . . . . . 2427<sup>a</sup>  
 OT references . . . . . 2426<sup>b</sup>  
 of Poor . . . . . 2420<sup>a</sup> (W. L. Walker)
- Powders . . . . . 2427<sup>b</sup>
- Power . . . . . 2427<sup>b</sup> (Orr)  
 of Omnipotence . . . . . 2188<sup>b</sup> (Vos)
- Power of Keys . . . . . 1794<sup>a</sup> (Carver)
- Praetorian Guard . . . . . 2427<sup>b</sup> (Rutherford); 258<sup>b</sup> (Allen)  
 Interpretation . . . . . 2428<sup>a</sup>  
 Paul and the . . . . . 2428<sup>a</sup>  
 of Paul, the Apostle . . . . . 2264<sup>b</sup> (A. T. Robertson)  
 of Philipians, Epistle to the . . . . . 2372<sup>a</sup> (Hayes)  
 of Praetorium . . . . . 2428<sup>b</sup> (Masterman)  
 Reference in Phil 1 13 . . . . . 2427<sup>b</sup>  
 of War . . . . . 3069<sup>b</sup> (Nicol)
- Praetorium . . . . . 2428<sup>b</sup> (Masterman)  
 of Gabbatha . . . . . 1150<sup>b</sup> (Masterman)  
 of Jerusalem . . . . . 1620<sup>a</sup> (Masterman)  
 of Judgment Hall . . . . . 1777<sup>b</sup> (Rutherford)  
 of Praetorian Guard . . . . . 2427<sup>b</sup> (Rutherford)
- Praise . . . . . 2429<sup>a</sup> (Lambert)  
 God the object of . . . . . 2429<sup>b</sup>  
 Man the object of . . . . . 2429<sup>a</sup>  
 of Persecution . . . . . 2323<sup>b</sup> (Rutherford)  
 of Singers, Singing . . . . . 2804<sup>b</sup> (Millar)  
 of Worship . . . . . 3110<sup>a</sup> (Crannell)
- Prayer . . . . . 2430<sup>a</sup> (Lambert)  
 In ancient Greece . . . . . 1302<sup>a</sup> (Fairbanks)

- Prayer—*continued*
- NT instances . . . . . 2430<sup>b</sup>
- OT cases . . . . . 2430<sup>a</sup>
- cf Pauline Theology . . . 2289<sup>a</sup> (Easton)
- cf Prayers of Jesus . . . 2431<sup>b</sup> (Bevan)
- cf Repetitions . . . . . 2559<sup>b</sup> (Easton)
- Prayer of Habakkuk
- cf Beth-horon, Battle of 446<sup>b</sup> (Maunder)
- cf Habakkuk . . . . . 1311<sup>a</sup> (Eiselen)
- Prayer, Hours of . . . . . 1434<sup>a</sup> (Dosker)
- Prayer of Joseph . . . . . 1741<sup>b</sup> (Easton)
- Prayer, Lord's . . . . . 1920<sup>b</sup> (Miller)
- Prayer of Manasses . . . 1979<sup>b</sup> (T. W. Davies)
- Prayer of Jesus . . . . . 2431<sup>b</sup> (Bevan)
- cf Intercession . . . . . 1484<sup>a</sup> (Bevan)
- cf Intercession of
- Christ . . . . . 1487<sup>b</sup> (Bevan)
- Other prayers . . . . . 2432<sup>b</sup>
- cf Points . . . . . 2415<sup>a</sup> (M. O. Evans)
- cf Prayer . . . . . 2430<sup>a</sup> (Lambert)
- Prayer in John 17 . . . . 2432<sup>a</sup>
- Teaching in regard to
- prayer . . . . . 2431<sup>b</sup>
- Preacher, Preaching . . . 2433<sup>a</sup> (Bauslin)
- Biblical references . . . 2433<sup>b</sup>
- Christ as preacher . . . . 2434<sup>b</sup>
- Need and limitations of 2433<sup>a</sup>
- Precept . . . . . 2434<sup>b</sup> (Edwards)
- cf Commandment . . . . . 679<sup>b</sup> (Jacobs)
- Precious . . . . . 2434<sup>b</sup> (Edwards)
- Precious Stones . . . . . 2856<sup>a</sup> (Fletcher)
- Precipitation
- cf Punishments . . . . . 2504<sup>b</sup> (Hirsch)
- Predestination . . . . . 2435<sup>a</sup> (J. Lindsay); 1130<sup>b</sup>  
(Hodge)
- Doctrine of . . . . . 2435<sup>a</sup>
- cf Election . . . . . 925<sup>b</sup> (Dunelm)
- cf Foreknow, Fore-  
knowledge . . . . . 1128<sup>a</sup> (Hodge)
- cf Foreordain, Fore-  
ordination . . . . . 1131<sup>a</sup> (Orr)
- History of doctrine . . . . 2435<sup>b</sup>
- Nature and impor-  
tance . . . . . 2435<sup>a</sup>
- cf Pauline Theology . . . 2289<sup>a</sup> (Easton)
- cf Providence . . . . . 2476<sup>b</sup> (Tillett)
- cf Purpose of God . . . . 2510<sup>a</sup>
- Two leading views . . . . . 2436<sup>a</sup>
- Preëminence . . . . . 2437<sup>a</sup>
- Prefer . . . . . 2437<sup>a</sup>
- Preparation . . . . . 2437<sup>a</sup> (Betteridge)
- Presbyter, Presbytery . . 2437<sup>b</sup> (Mack)
- cf Bishop . . . . . 478<sup>b</sup> (Dosker)
- cf Church . . . . . 650<sup>b</sup> (Lambert)
- cf Elder, NT and OT . 924<sup>a</sup> (Grant); 923<sup>b</sup>  
(Stearns)
- cf Government . . . . . 1287<sup>a</sup> (Heidel)
- cf John, Epistles of . . . 1718<sup>a</sup> (Law)
- cf John, Gospel of . . . 1721<sup>b</sup> (Iverach)
- Principle in Scripture
- and history . . . . . 2438<sup>a</sup>
- Use in NT . . . . . 2437<sup>b</sup>
- Presence . . . . . 2438<sup>a</sup> (Easton)
- cf Parousia . . . . . 2249<sup>a</sup> (Easton)
- Present
- cf Gift . . . . . 1228<sup>a</sup> (W. L. Walker)
- Presently . . . . . 2438<sup>b</sup>
- President . . . . . 2438<sup>b</sup>
- Press . . . . . 2438<sup>b</sup>
- cf Vine . . . . . 3049<sup>b</sup> (Masterman)
- cf Wine, Wine Press . . 3086<sup>a</sup> (Easton)
- Pressfat . . . . . 2438<sup>b</sup>
- cf Wine, Wine Press . . 3086<sup>a</sup> (Easton)
- Presume, Presumptuous,
- Presumptuously . . . . . 2438<sup>b</sup> (W. L. Walker)
- Prevent . . . . . 2438<sup>b</sup> (W. L. Walker)
- Prey . . . . . 2439<sup>a</sup> (W. L. Walker)
- cf Booty . . . . . 503<sup>b</sup> (W. L. Walker)
- cf War, Warfare . . . . . 3071<sup>b</sup> (Nicol)
- Price . . . . . 2439<sup>a</sup>
- cf Dog . . . . . 867<sup>b</sup> (Day)
- Prick . . . . . 2439<sup>a</sup> (Edwards)
- cf Goad . . . . . 1248<sup>b</sup> (Patch)
- Priest . . . . . 2439<sup>a</sup> (Moorehead)
- Aaron and his sons . . . . 2441<sup>a</sup>
- cf Christ, Offices of . . . 616<sup>b</sup> (Bevan)
- Functions and char-  
acter . . . . . 2440<sup>a</sup>
- cf Mediation . . . . . 2019<sup>b</sup> (Edwards)
- Melchizedek and
- Aaron . . . . . 2440<sup>a</sup>
- Nature of the office . . . 2439<sup>b</sup>
- cf Priest, High . . . . . 2441<sup>b</sup> (Reeve)
- Priest, High . . . . . 2441<sup>b</sup> (Reeve)
- cf Abiathar . . . . . 7<sup>b</sup> (Beecher)
- cf Annas . . . . . 137<sup>a</sup> (Edwards)
- cf Caiaphas . . . . . 538<sup>b</sup> (Kerr)
- cf Christ, Offices of . . . 616<sup>b</sup> (Bevan)
- Dress and duties . . . . . 2442<sup>a</sup>
- History of the office . . . 2442<sup>b</sup>
- Institution . . . . . 2441<sup>b</sup>
- cf Jesus Christ . . . . . 1624<sup>a</sup> (Orr)
- In NT . . . . . 2443<sup>b</sup>
- In OT . . . . . 2443<sup>a</sup>
- cf Paul, the Apostle . . . 2264<sup>b</sup> (A. T. Robertson)
- cf Priest . . . . . 2439<sup>a</sup> (Moorehead)
- cf Priesthood . . . . . 2444<sup>a</sup> (Moorehead)
- cf Priesthood in NT . . . 2445<sup>a</sup> (Estes)
- Priesthood . . . . . 2444<sup>a</sup> (Moorehead)
- Of Christ . . . . . 2024<sup>b</sup> (Edwards)
- cf Christ, Offices of . . . 618<sup>a</sup> (Bevan)
- cf Maccabaeus . . . . . 1952<sup>a</sup> (T. W. Davies)
- cf Micah . . . . . 2045<sup>b</sup> (Lees)
- In NT . . . . . 2444<sup>b</sup>
- In OT . . . . . 2444<sup>a</sup>
- cf Priest, High . . . . . 2441<sup>b</sup> (Reeve)
- cf Priesthood in NT . . . 2445<sup>a</sup> (Estes)
- Priesthood in the NT . . . 2445<sup>a</sup> (Estes)
- Jewish priesthood . . . . . 2445<sup>b</sup>
- cf Priest, High . . . . . 2441<sup>b</sup> (Reeve)
- cf Priesthood . . . . . 2444<sup>a</sup> (Moorehead)
- Priesthood of believers 2446<sup>b</sup>
- Priesthood of Jesus . . . 2445<sup>b</sup>

- Priests and Levites . . . . . 2446<sup>b</sup> (Wiener)  
   Aaron and his sons . . . . . 2449<sup>a</sup>  
   of Agrarian Laws . . . . . 74<sup>a</sup> (Wiener)  
   of Archaeology and  
     Criticism . . . . . 226<sup>a</sup> (Kyle)  
   of Blessing . . . . . 487<sup>b</sup> (Gray)  
   of Breastplate . . . . . 253<sup>b</sup> (Nicol)  
   of Chemarim . . . . . 601<sup>a</sup> (Van Pelt)  
   Chronicles . . . . . 2451<sup>b</sup>  
   of Criticism of Bible . . . . . 748<sup>b</sup> (Orr)  
   of Doorkeeper . . . . . 869<sup>a</sup> (Hovey)  
   of Dress . . . . . 875<sup>b</sup> (Eager)  
   of Ephod . . . . . 962<sup>a</sup> (Sampey)  
   Ezekiel . . . . . 2451<sup>a</sup>  
   of First Fruits . . . . . 1114<sup>a</sup> (Levertoff)  
   of Firstborn, Firstling . . . . . 1113<sup>b</sup> (T. Lewis)  
   of Judge . . . . . 1771<sup>b</sup> (Levertoff)  
   Legal provisions . . . . . 2452<sup>a</sup>  
   of Levi . . . . . 1868<sup>b</sup> (Ewing)  
   Levites, the . . . . . 2448<sup>a</sup>  
   of Levitical Cities . . . . . 1869<sup>a</sup> (Wiener)  
   of Mediation, Media-  
     tor . . . . . 2018<sup>a</sup> (Edwards)  
   of Mitre . . . . . 2067<sup>b</sup> (T. Lewis)  
   of Nethinim . . . . . 2139<sup>b</sup> (Lees)  
   Old and new views . . . . . 2447<sup>a</sup>  
   Other parts of Penta-  
     teuch than Leviticus . . . . . 2449<sup>b</sup>  
     of Pentateuch . . . . . 2298<sup>a</sup> (Wiener)  
   Priest code, the . . . . . 2448<sup>a</sup>  
   of Sacrifice, NT . . . . . 2651<sup>a</sup> (Williams)  
   of Sanctuary . . . . . 2686<sup>b</sup> (Wiener)  
   of Singers . . . . . 2804<sup>b</sup> (Millar)  
   of Sons of Solomon's  
     Servants . . . . . 2825<sup>b</sup> (Mack)  
   Sources, the . . . . . 2450<sup>a</sup>  
   of Stranger and So-  
     journer in OT . . . . . 2865<sup>a</sup> (Wiener)  
   Tithes . . . . . 2987<sup>b</sup> (Levertoff)  
   of Urim and Thummim . . . . . 3040<sup>b</sup> (N. Isaacs)  
   of Zabud . . . . . 3128<sup>b</sup> (Roberts)  
   of Zadok . . . . . 3129<sup>b</sup> (Whitelaw)
- Primogeniture . . . . . 2452<sup>b</sup> (N. Isaacs)  
   Biblical references . . . . . 2452<sup>b</sup>  
   of Birthright . . . . . 478<sup>a</sup> (J. M. Wilson)  
   Double portion . . . . . 2452<sup>b</sup>  
   of Firstborn, Firstling . . . . . 1113<sup>b</sup> (T. Lewis)  
   Law of firstborn . . . . . 2453<sup>a</sup>
- Prince . . . . . 2453<sup>a</sup> (Baur)  
   of Governor . . . . . 1289<sup>b</sup> (Heidel)  
   Nasi . . . . . 2454<sup>a</sup>  
   Other terms . . . . . 2454<sup>a</sup>  
   Sar . . . . . 2453<sup>b</sup>  
   Terms used . . . . . 2453<sup>a</sup>
- Princes, The Seven  
   of Prince . . . . . 2453<sup>a</sup> (Baur)
- Princess . . . . . 2454<sup>b</sup> (Baur)
- Principal . . . . . 2454<sup>b</sup>
- Principality . . . . . 2454<sup>b</sup> (Heidel)  
   of Angel . . . . . 132<sup>b</sup> (J. M. Wilson)  
   of Satan . . . . . 2693<sup>b</sup> (Sweet)
- Principles . . . . . 2455<sup>a</sup>  
   of Element . . . . . 927<sup>b</sup>  
   of Rudiments . . . . . 2624<sup>b</sup> (Rutherford)
- Print, Printing, Printed . . . . . 2455<sup>a</sup> (Richardson)  
   of Book . . . . . 495<sup>b</sup> (Richardson)  
   Early writing . . . . . 2455<sup>a</sup>  
   of Ink-horn . . . . . 1469<sup>b</sup> (Richardson)  
   of Mark . . . . . 1985<sup>b</sup> (Pratt)  
   Materials . . . . . 2455<sup>b</sup>  
   of Seal . . . . . 2708<sup>a</sup> (Edwards)  
   of Text and MSS of NT . . . . . 2950<sup>b</sup> (Sitterly)  
   of Writing . . . . . 3121<sup>a</sup> (Richardson)
- Prisca, Priscilla  
   of Aquila . . . . . 211<sup>a</sup> (Kapp)
- Prison, Prisoner . . . . . 2456<sup>a</sup> (T. Lewis)  
   Causes for imprison-  
     ment . . . . . 2456<sup>a</sup>  
   Garments . . . . . 2456<sup>b</sup>  
   NT usage . . . . . 2456<sup>b</sup>  
   of Punishments . . . . . 2504<sup>b</sup> (Hirsch)  
   References to . . . . . 2456<sup>a</sup>
- Prison, Spirits in . . . . . 2456<sup>b</sup> (Orr)  
   of Eschatology of NT . . . . . 979<sup>b</sup> (Vos)  
   of Peter, The First  
     Epistle of . . . . . 2351<sup>b</sup> (Moorehead)
- Privy, Privily . . . . . 2457<sup>a</sup>  
   of Tormah . . . . . 2999<sup>b</sup>
- Prize . . . . . 2457<sup>a</sup> (Edwards)  
   of Grasp . . . . . 1293<sup>a</sup> (Miller)  
   of Humiliation of Christ . . . . . 2345<sup>a</sup> (Warfield)  
   of Kenosis . . . . . 1792<sup>a</sup> (Easton)
- Probation, Second  
   of Eschatology of NT . . . . . 979<sup>b</sup> (Vos)
- Prochorus . . . . . 2457<sup>b</sup>
- Proconsul . . . . . 2457<sup>b</sup>  
   of Province . . . . . 2485<sup>b</sup> (Allen)
- Procurator . . . . . 2457<sup>b</sup> (Allen)  
   Administration of . . . . . 2458<sup>a</sup>  
   of Governor . . . . . 1289<sup>b</sup> (Heidel)  
   List of Judaeen pro-  
     curators . . . . . 2458<sup>a</sup>  
   of Pilate, Pontius . . . . . 2396<sup>a</sup> (J. M. Wilson)  
   of Province . . . . . 2485<sup>b</sup> (Allen)  
   of Rome . . . . . 2621<sup>b</sup> (Allen)
- Profane . . . . . 2458<sup>b</sup> (W. L. Walker)
- Profess, Profession . . . . . 2458<sup>b</sup> (W. L. Walker)
- Prognosticators, Monthly  
   of Astrology . . . . . 295<sup>b</sup> (Maunder)
- Prologue . . . . . 2458<sup>b</sup>  
   of John, Gospel of . . . . . 1720<sup>a</sup> (Iverach)  
   of Sirach . . . . . 2806<sup>b</sup> (T. W. Davies)
- Prolong . . . . . 2459<sup>a</sup> (W. L. Walker)
- Promise . . . . . 2459<sup>a</sup> (W. L. Walker)
- Proper . . . . . 2459<sup>b</sup>
- Proper Names . . . . . 2113<sup>a</sup> (Davis)
- Property  
   of Agrarian Laws . . . . . 74<sup>a</sup> (Wiener)  
   of Patrimony . . . . . 2264<sup>a</sup> (Mack)  
   of Poor . . . . . 2420<sup>a</sup> (W. L. Walker)  
   of Portion . . . . . 2422<sup>b</sup> (Easton)  
   of Primogeniture . . . . . 2452<sup>b</sup> (N. Isaacs)  
   of Wealth . . . . . 3076<sup>a</sup> (W. Evans)



- Prophecy, Gift of  
 of Spiritual Gifts . . . . . 2843<sup>a</sup> (Lambert)
- Prophecy, Prophets . . . . . 2459<sup>b</sup> (Orelli)  
 of Accommodation . . . . . 30<sup>a</sup> (Sweet)  
 Amos and Hosea . . . . . 2463<sup>a</sup>  
 of Apocalyptic Literature . . . . . 161<sup>b</sup> (J. E. H. Thomson)
- Contribution of Habakkuk . . . . . 1313<sup>a</sup> (Eiselen)  
 Faithfulness . . . . . 1313<sup>a</sup>  
 Universality of Jehovah . . . . . 1313<sup>a</sup>
- Contribution of Haggai . . . . . 1318<sup>b</sup> (Robinson)  
 Necessity of rebuilding the temple . . . . . 1318<sup>b</sup>
- Contribution of Hosea 1428<sup>b</sup> (J. Robertson)  
 Divination . . . . . 2466<sup>a</sup>; 860<sup>a</sup> (T. W. Davies)  
 Dreams . . . . . 2460<sup>a</sup>  
 Elijah and Elisha . . . . . 2462<sup>b</sup>  
 Exilic age . . . . . 2463<sup>b</sup>  
 of Foretelling, Foretold . . . . . 1132<sup>a</sup>  
 of Greece, Religion of . 1297<sup>a</sup> (Fairbanks)  
 History of, in Israel . . . . . 2461<sup>b</sup>  
 Inspiration . . . . . 2460<sup>a</sup>  
 of Israel, Religion of . 1530<sup>b</sup> (Orelli)  
 of Messiah . . . . . 2039<sup>a</sup> (Crichton)  
 Messianic idea . . . . . 2464<sup>b</sup>  
 of Micaiah . . . . . 2047<sup>a</sup> (Lees)  
 of Ministry . . . . . 2058<sup>b</sup> (T. M. Lindsay)  
 NT examples . . . . . 2464<sup>a</sup>  
 Non-Hebrew prophecy 2464<sup>b</sup>  
 Prediction and fulfillment . . . . . 2461<sup>a</sup>  
 of Prophecyings, False 2466<sup>b</sup> (Schenk)  
 of Prophetess . . . . . 2466<sup>b</sup> (Schenk)  
 of Revelation . . . . . 2577<sup>a</sup> (Warfield)  
 Schools of prophets . . . . . 2462<sup>a</sup>  
 Seer . . . . . 2459<sup>a</sup>; 2713<sup>a</sup>  
 of Shiloh . . . . . 2768<sup>b</sup> (Orr)  
 Visions . . . . . 2460<sup>b</sup>
- Prophecyings, False . . . . . 2466<sup>b</sup> (Schenk); 747<sup>b</sup>  
 (Hirsch)  
 of Prophecy . . . . . 2459<sup>b</sup> (Orelli)
- Prophet, The Old . . . . . 2183<sup>b</sup> (Roberts)
- Prophetess . . . . . 2466<sup>b</sup> (Schenk)  
 of Prophecy . . . . . 2460<sup>b</sup> (Orelli)
- Propitiation . . . . . 2467<sup>a</sup> (Carver)  
 of Atonement . . . . . 321<sup>a</sup> (Carver)  
 of Atonement, Day of . 324<sup>b</sup> (Möller)  
 of Johannine Theology 1701<sup>b</sup> (Law)  
 of Mediation, Mediator . . . . . 2018<sup>a</sup> (Edwards)  
 of Mercy-seat, The . . . . . 2036<sup>a</sup> (Caldecott)  
 of Pauline Theology . . . . . 2289<sup>a</sup> (Easton)  
 of Reconcile, Reconciliation . . . . . 2536<sup>a</sup> (M'Caig)  
 of Romans, Epistle to . . . . . 2617<sup>a</sup> (Dunelm)  
 Term and meaning . . . . . 2467<sup>a</sup>  
 Theological implication 2467<sup>b</sup>
- Proportion . . . . . 2467<sup>b</sup>
- Proselyte . . . . . 2467<sup>b</sup> (Levertoff)  
 NT references . . . . . 2468<sup>b</sup>  
 OT *ger* . . . . . 2467<sup>b</sup>  
 Proselytizing . . . . . 2467<sup>a</sup>  
 of Rome . . . . . 2622<sup>a</sup> (Allen)  
 of Stranger and Sojourner in OT . . . . . 2865<sup>a</sup> (Wiener)  
 Talmudic regulations . 2469<sup>a</sup>  
 of Titus, or Titius Justus . . . . . 2989<sup>b</sup> (Rutherford)
- Proselyte Baptism . . . . . 386<sup>a</sup> (A. T. Robertson)
- Proseuche, Proseucha . . . . . 2469<sup>b</sup>  
 of Philippi . . . . . 2369<sup>a</sup> (Tod)
- Prostitution  
 of Crimes . . . . . 747<sup>b</sup> (Hirsch)  
 of Harlot . . . . . 1339<sup>b</sup> (Eager)  
 of Punishments . . . . . 2504<sup>b</sup> (Hirsch)
- Prostration  
 of Attitudes . . . . . 329<sup>a</sup> (W. W. Davies)
- Protevangelium of James 198<sup>a</sup> (Hutchison)
- Prove . . . . . 2469<sup>b</sup> (W. L. Walker)  
 of Tempt . . . . . 2942<sup>b</sup> (Stuart)
- Provender . . . . . 2469<sup>b</sup> (Masterman)
- Proverb . . . . . 2469<sup>b</sup> (Genung)  
 Folk meaning and use 2470<sup>a</sup>  
 of Games . . . . . 1168<sup>b</sup> (Smith)  
 Literary growth . . . . . 2470<sup>b</sup>  
 of Proverbs, Book of . 2471<sup>b</sup> (Genung)  
 of Wisdom . . . . . 3089<sup>a</sup> (Easton)  
 Wisdom idea . . . . . 2471<sup>a</sup>
- Proverbs, Book of . . . . . 2471<sup>b</sup> (Genung)  
 Age and literary kinship . . . . . 2474<sup>b</sup>  
 of Agur . . . . . 78<sup>a</sup> (Genung)  
 Conception of Wisdom 2474<sup>b</sup>  
 of Hezekiah, The Men of . . . . . 1388<sup>b</sup>  
 of Job, Book of . . . . . 1679<sup>b</sup> (Genung)  
 of Lemuel . . . . . 1865<sup>b</sup> (Genung)  
 Nucleus, and later additions . . . . . 2472<sup>b</sup>  
 Philosophic effort . . . . . 2473<sup>b</sup>  
 of Proverb . . . . . 2469<sup>b</sup> (Genung)  
 Successive compilations . . . . . 2472<sup>a</sup>  
 Title and author . . . . . 2471<sup>b</sup>  
 of Wisdom . . . . . 3089<sup>a</sup> (Easton)
- Providence . . . . . 2476<sup>b</sup> (Tillett)  
 of Affliction . . . . . 66<sup>a</sup> (Edwards)  
 Biblical views . . . . . 2477<sup>a</sup>  
 of Choose, Chosen . . . . . 612<sup>b</sup> (Rees)  
 Content of the Biblical doctrine . . . . . 2481<sup>a</sup>  
 Definition . . . . . 2476<sup>b</sup>  
 of Foreordain, Foreordination . . . . . 1131<sup>a</sup> (Orr)  
 Free will and . . . . . 2483<sup>b</sup>  
 of Israel, History of the People . . . . . 1511<sup>b</sup> (Orelli)  
 Job . . . . . 2478<sup>b</sup>  
 of Job, Book of . . . . . 1679<sup>b</sup> (Genung)  
 Natural and moral evil 2484<sup>b</sup>

- Providence—*continued*  
 NT conceptions . . . . . 2479<sup>b</sup>  
 OT ideas of . . . . . 2477<sup>b</sup>  
 OT and NT ideas compared . . . . . 2480<sup>b</sup>  
 cf Predestination . . . . . 2436<sup>b</sup> (J. Lindsay)  
 Prophetic ideas of . . . . . 2479<sup>b</sup>  
 Purpose . . . . . 2482<sup>a</sup>  
 Special providence . . . . . 2482<sup>b</sup>  
 Spheres of . . . . . 2477<sup>a</sup>  
 cf Will . . . . . 3085<sup>a</sup> (W. L. Walker)
- Province . . . . . 2485<sup>b</sup> (Allen)  
 Judaea . . . . . 2486<sup>a</sup>  
 Meaning . . . . . 2485<sup>b</sup>  
 cf Pilate, Pontius . . . . . 2396<sup>a</sup> (J. M. Wilson)  
 cf Procurators . . . . . 2457<sup>b</sup> (Allen)  
 Roman administration 2486<sup>a</sup>
- Provocation . . . . . 2486<sup>b</sup> (W. L. Walker)  
 Provoke . . . . . 2486<sup>b</sup> (W. L. Walker)  
 Prudence . . . . . 2486<sup>b</sup> (W. L. Walker)  
 cf Wisdom . . . . . 3089<sup>a</sup> (Easton)
- Prudent . . . . . 2486<sup>b</sup> (W. L. Walker)
- Pruning-hook  
 cf Hook . . . . . 1419<sup>a</sup> (Easton)  
 cf Vine . . . . . 3049<sup>b</sup> (Masterman)
- Psalms  
 cf Asaph . . . . . 262<sup>b</sup> (Millar)  
 cf Higgaion . . . . . 1389<sup>b</sup>  
 cf Hind of the Morning,  
 The . . . . . 1393<sup>a</sup> (M. O. Evans)  
 cf Jonath Elem Reho-  
 kim . . . . . 1730<sup>a</sup>  
 cf Mahalath . . . . . 1965<sup>b</sup> (Orr)  
 cf Muth-labben . . . . . 2102<sup>a</sup>  
 cf Palestine . . . . . 2218<sup>b</sup> (Conder)
- Psalms, Book of . . . . . 2487<sup>a</sup> (Sampey)  
 Gospel in the Psalter . . . . . 2492<sup>a</sup>  
 Growth of . . . . . 2491<sup>a</sup>  
 Imprecatory psalms . . . . . 2494<sup>a</sup>  
 Messianic element . . . . . 2492<sup>b</sup>  
 Number and place . . . . . 2487<sup>a</sup>  
 Poetry of . . . . . 2491<sup>b</sup>  
 cf Poetry, Hebrew . . . . . 2410<sup>a</sup> (T. W. Davies)  
 Problem of sin . . . . . 2493<sup>a</sup>  
 Relation of David to . . . . . 2489<sup>a</sup>  
 cf Selah . . . . . 2096<sup>b</sup> (Millar)  
 cf Shiggaion . . . . . 2767<sup>b</sup>  
 Speaker in the . . . . . 2492<sup>a</sup>  
 Superscriptions . . . . . 2487<sup>b</sup>  
 Temple psalms . . . . . 2490<sup>b</sup>  
 Title . . . . . 2487<sup>a</sup>
- Psalms of David . . . . . 795<sup>b</sup> (Weir)
- Psalms, Imprecatory  
 cf Psalms, Book of . . . . . 2494<sup>a</sup> (Sampey)
- Psalms (Psalter) of Solomon  
 cf Apocalyptic Literature . . . . . 161<sup>b</sup> (J. E. H. Thomson)  
 cf Between the Testaments . . . . . 455<sup>a</sup> (Dosker)  
 cf Messiah . . . . . 2042<sup>a</sup> (Crichton)
- Psaltery  
 cf Music . . . . . 2098<sup>b</sup> (Millar)
- Psaltiel . . . . . 2494<sup>b</sup>
- Pseudepigrapha . . . . . 174<sup>a</sup> (J. E. H. Thomson);  
 . . . . . 457<sup>b</sup> (Dosker)
- Pseudo-Matthew, Apocryphal Gospel of . . . . . 198<sup>b</sup> (Hutchison)
- Psychology . . . . . 2494<sup>b</sup> (Marais)  
 Creationism . . . . . 2495<sup>b</sup>  
 Death and immortality . . . . . 2499<sup>a</sup>  
 cf Death . . . . . 811<sup>b</sup> (Bavinck)  
 Fall of man . . . . . 2498<sup>a</sup>  
 cf Fall, The . . . . . 1092<sup>a</sup> (Bavinck)  
 cf Heart . . . . . 1350<sup>b</sup> (Marais)  
 cf Kidneys . . . . . 1797<sup>b</sup> (Easton)  
 Monism . . . . . 2497<sup>b</sup>  
 Pauline expressions . . . . . 2497<sup>b</sup>  
 cf Resurrection . . . . . 2562<sup>a</sup> (Easton)  
 Scope of Biblical psychology . . . . . 2494<sup>b</sup>  
 Scripture terms . . . . . 2496<sup>b</sup>  
 cf Sensual . . . . . 2721<sup>a</sup> (Pratt)  
 Soul, the . . . . . 2495<sup>a</sup>  
 cf Soul . . . . . 2837<sup>a</sup> (Marais)  
 cf Spirit . . . . . 2841<sup>b</sup> (Marais)  
 Trichotomy . . . . . 2496<sup>a</sup>
- Ptolemais . . . . . 2499<sup>a</sup>  
 cf Acco . . . . . 28<sup>a</sup> (Porter)  
 cf Phoenicia . . . . . 2386<sup>a</sup> (Porter)
- Ptolemy . . . . . 2499<sup>b</sup> (Angus)  
 cf Macron . . . . . 1960<sup>b</sup> (Angus)  
 cf Septuagint . . . . . 2722<sup>a</sup> (Thackeray)
- Ptolemy Philadelphus . . . . . 456<sup>b</sup> (Dosker)  
 cf Septuagint . . . . . 2723<sup>a</sup> (Thackeray)
- Ptolemy Soter . . . . . 456<sup>b</sup> (Dosker)
- Puah, Puvah . . . . . 2501<sup>a</sup> (E. D. Isaacs)
- Publican  
 cf Tax, Taxing . . . . . 2918<sup>a</sup> (Sweet)
- Publius . . . . . 2501<sup>a</sup> (Kerr)  
 cf Apocryphal Acts . . . . . 183<sup>b</sup> (A. F. Findlay)  
 cf Melita . . . . . 2029<sup>b</sup> (Allen)
- Pudens . . . . . 2501<sup>a</sup> (Rutherford)  
 cf Claudia . . . . . 666<sup>a</sup> (Jacobs)
- Puhites (Puthites) . . . . . 2511<sup>a</sup>
- Pul . . . . . 2501<sup>b</sup>  
 cf Put . . . . . 2510<sup>a</sup> (Pinches)  
 cf Tiglath-pileser . . . . . 2980<sup>b</sup> (Nicol)
- Pulpit . . . . . 2501<sup>b</sup>
- Pulse . . . . . 2501<sup>b</sup>
- Punishment, Everlasting 2501<sup>b</sup> (Orr)  
 Annihilation . . . . . 2503<sup>b</sup>  
 cf Eschatology of NT . . . . . 979<sup>b</sup> (Vos)  
 cf Eschatology of OT . . . . . 972<sup>a</sup> (Orr)  
 cf Gulf . . . . . 1310<sup>b</sup> (M. O. Evans)  
 cf Hell . . . . . 1371<sup>a</sup> (Orr)  
 cf Immortal, Immortality . . . . . 1461<sup>a</sup> (Orr)  
 Nature of punishment . . . . . 2503<sup>b</sup>  
 Probation . . . . . 2503<sup>b</sup>  
 cf Restoration . . . . . 2561<sup>b</sup> (Miller)  
 cf Retribution . . . . . 2570<sup>a</sup> (M'Caig)

- Punishment, Everlasting—*continued*  
 Scriptural teaching . . . . . 2502<sup>a</sup>  
 Survival of death . . . . . 2501<sup>b</sup>  
 Universal salvation . . . . . 2503<sup>a</sup>  
 cf Unquenchable Fire . . . . . 3038<sup>a</sup> (Orr)
- Punishments . . . . . 2504<sup>b</sup> (Hirsch)  
 cf Brand . . . . . 514<sup>a</sup>  
 cf Burning . . . . . 532<sup>a</sup>  
 Capital punishments . . . . . 2505<sup>a</sup>  
 cf Eunuch . . . . . 1037<sup>a</sup> (Eager)  
 Foreign punishments . . . . . 2505<sup>b</sup>  
 cf Hanging . . . . . 1335<sup>b</sup> (Hirsch)  
 Hebrew law . . . . . 2504<sup>a</sup>  
 cf Herod . . . . . 1378<sup>b</sup> (Dosker)  
 cf Law in NT . . . . . 1844<sup>a</sup> (M'Caig)  
 cf Polygamy . . . . . 2416<sup>a</sup> (Caverno)  
 cf Prison . . . . . 2456<sup>a</sup> (T. Lewis)  
 cf Scorpion . . . . . 2703<sup>b</sup> (Day)  
 cf Scourging . . . . . 2704<sup>a</sup> (Dosker)  
 cf Seduce, Seducer . . . . . 2712<sup>a</sup> (Edwards)  
 cf Slander . . . . . 2814<sup>b</sup> (Edwards)  
 cf Slavery . . . . . 2815<sup>a</sup> (Raffety)  
 cf Stock . . . . . 2854<sup>b</sup>  
 cf Uncleaness . . . . . 3036<sup>b</sup> (Williams)  
 cf Visitation . . . . . 3058<sup>a</sup> (Edwards)
- Punites . . . . . 2506<sup>a</sup>  
 Punon . . . . . 2506<sup>a</sup>  
 cf Wanderings of Israel . . . . . 3064<sup>a</sup> (Conder)
- Pur  
 cf Purim . . . . . 2506<sup>b</sup> (Mack)
- Purah . . . . . 2506<sup>a</sup>  
 Purchase . . . . . 2506<sup>a</sup> (Easton)  
 Pure, Purely, Purity . . . . . 2506<sup>b</sup> (W. L. Walker)  
 cf Clean . . . . . 667<sup>a</sup> (Crannell)  
 cf Purity . . . . . 2507<sup>b</sup> (Caverno)
- Purge . . . . . 2506<sup>b</sup> (Mack)
- Purification  
 cf Purge . . . . . 2506<sup>b</sup> (Mack)  
 cf Purity . . . . . 2507<sup>b</sup> (Caverno)  
 cf Uncleaness . . . . . 3036<sup>b</sup> (Williams)
- Purim . . . . . 2506<sup>b</sup> (Mack)  
 cf Agagite . . . . . 69<sup>a</sup> (Wolf)  
 History of . . . . . 2507<sup>a</sup>  
 Manner of observance . . . . . 2507<sup>a</sup>  
 Origin . . . . . 2507<sup>b</sup>  
 cf Phurrai . . . . . 2392<sup>a</sup>
- Purity . . . . . 2507<sup>b</sup> (Caverno)  
 Christ's teachings . . . . . 2509<sup>a</sup>  
 cf Divorce in NT . . . . . 865<sup>a</sup> (Caverno)  
 cf Divorce in OT . . . . . 863<sup>b</sup> (W. W. Davies)  
 Prophetic teaching . . . . . 2508<sup>a</sup>  
 cf Pure, Purely . . . . . 2506<sup>b</sup> (W. L. Walker)  
 Sex relations . . . . . 2508<sup>a</sup>  
 Song of Songs . . . . . 2508<sup>b</sup>  
 cf Unwashed . . . . . 3038<sup>b</sup> (Williams)
- Purlouning . . . . . 2509<sup>b</sup>  
 Purple . . . . . 2509<sup>b</sup> (Day)  
 cf Colors . . . . . 674<sup>b</sup> (Patch)  
 cf Dye, Dyeing . . . . . 883<sup>b</sup> (Patch)  
 Sidon . . . . . 2785<sup>a</sup> (Porter)
- Purpose of God . . . . . 2510<sup>a</sup>  
 cf Foreordination . . . . . 1131<sup>a</sup> (Orr)  
 cf Predestination . . . . . 2435<sup>a</sup> (J. Lindsay)
- Purse  
 cf Bag . . . . . 377<sup>a</sup> (Eager)
- Purslain Juice  
 cf Juice . . . . . 1780<sup>b</sup>
- Purtenance . . . . . 2510<sup>a</sup>  
 Put . . . . . 2510<sup>a</sup> (Pinches)  
 cf Pul . . . . . 2501<sup>b</sup>
- Put Asunder . . . . . 316<sup>b</sup> (S. F. Hunter)  
 Puteoli . . . . . 2510<sup>b</sup> (Allen)  
 cf Nero . . . . . 2134<sup>b</sup> (Angus)
- Puthites . . . . . 2511<sup>a</sup>  
 Putiel . . . . . 2511<sup>a</sup>  
 cf Phinehas . . . . . 2385<sup>b</sup> (Wallace)
- Puvah  
 cf Puah . . . . . 2501<sup>a</sup> (E. D. Isaacs)
- Pygarg . . . . . 2511<sup>a</sup> (Day)  
 cf Zoology . . . . . 3155<sup>a</sup> (Day)
- Pyramid . . . . . 2511<sup>b</sup> (Ewing)  
 Pyrrhus . . . . . 2511<sup>b</sup>  
 cf Sopater . . . . . 2836<sup>a</sup>
- Python . . . . . 2511<sup>b</sup> (Easton)  
 cf Divination . . . . . 860<sup>a</sup> (T. W. Davies)
- Qoph  
 cf Koph . . . . . 1816<sup>b</sup>
- Quail . . . . . 2512<sup>a</sup> (Stratton-Porter)  
 cf Food . . . . . 1124<sup>a</sup> (Eager)  
 cf Moses . . . . . 2087<sup>a</sup> (Kyle)  
 cf Partridge . . . . . 2254<sup>a</sup> (Stratton-Porter)
- Quarrel . . . . . 2512<sup>b</sup>  
 Quarries . . . . . 2512<sup>b</sup> (Day)  
 cf Shebarim . . . . . 2753<sup>b</sup>
- Quarter . . . . . 2513<sup>a</sup>  
 cf Border . . . . . 503<sup>b</sup> (Hirsch)  
 cf Coast . . . . . 672<sup>a</sup> (Day)
- Quartus . . . . . 2513<sup>a</sup>  
 Quaternion . . . . . 2513<sup>a</sup> (Nicol)
- Queen . . . . . 2513<sup>b</sup> (Baur)  
 cf King's Mother . . . . . 1808<sup>a</sup>  
 cf Queen of Heaven . . . . . 2514<sup>a</sup> (Nicol)
- Queen of Heaven . . . . . 2514<sup>a</sup> (Nicol)  
 cf Queen . . . . . 2513<sup>b</sup> (Baur)
- Queen Mother . . . . . 2513<sup>b</sup> (Baur)  
 Biblical references . . . . . 2514<sup>a</sup>  
 cf King's Mother . . . . . 1808<sup>a</sup>  
 Mother of king . . . . . 2513<sup>b</sup>  
 cf Relationships, Family . . . . . 2554<sup>a</sup> (N. and E. D. Isaacs)
- Queen of Sheba . . . . . 2514<sup>b</sup> (Roberts)
- Quench . . . . . 2515<sup>a</sup> (Gerberding)  
 Question . . . . . 2515<sup>a</sup> (Easton)
- Quick, Quicken . . . . . 2515<sup>a</sup> (Estes)
- Quicksands  
 cf Syrtis . . . . . 2886<sup>b</sup>
- Quiet . . . . . 2515<sup>b</sup> (M. O. Evans)  
 cf Meekness . . . . . 2027<sup>a</sup> (W. L. Walker)  
 cf Poor . . . . . 2420<sup>a</sup> (W. L. Walker)
- Quintus Memmius . . . . . 2030<sup>b</sup> (Angus)

- Quirinius  
   of Chronology of the  
     NT . . . . . 644<sup>b</sup> (Armstrong)  
   of Jesus Christ (Birth) . 1628<sup>b</sup> (Orr)  
   of Judas of Galilee . . . 1767<sup>a</sup> (Orr)  
   of Luke, Gospel of . . . 1936<sup>b</sup> (A. T. Robertson)
- Quit . . . . . 2515<sup>b</sup>  
 Quiver . . . . . 2515<sup>b</sup>  
 Quotations, NT . . . . . 2515<sup>b</sup> (Sweet)  
   of Accommodation . . . 29<sup>a</sup> (Sweet)  
   Argument . . . . . 2519<sup>a</sup>  
   Authority of OT . . . . . 2516<sup>b</sup>  
   of Chronicles, Books of 629<sup>b</sup> (Beecher)  
   Examples of . . . . . 2516<sup>b</sup>  
   of Immanuel . . . . . 1457<sup>b</sup> (A. W. Evans)  
   of Poetry, NT . . . . . 2414<sup>b</sup> (Schenk)  
   Provision of Christian-  
     ity in OT . . . . . 2517<sup>b</sup>  
   Unity of two dispensa-  
     tions . . . . . 2516<sup>a</sup>  
   of Virgin-birth . . . . . 3052<sup>a</sup> (Sweet)
- Quotations from the OT  
   of Mark, Gospel of . . . 1988<sup>a</sup> (Farmer)  
   of Matthew, Gospel of . 2011<sup>a</sup> (Schodde)
- Raama, Raamah . . . . . 2520<sup>a</sup> (Fulton)  
 Raamiah (Reclaiiah) . . . 2520<sup>a</sup>; 2545<sup>a</sup>  
 Raamses, Rameses . . . . . 2520<sup>a</sup> (Conder)  
   of Exodus, The . . . . . 1052<sup>a</sup> (Conder)  
   of Exodus, Book of . . . 1056<sup>b</sup> (Möller)  
   of Goshen . . . . . 1280<sup>a</sup> (Conder)  
   of Pithom . . . . . 2401<sup>b</sup> (Conder)  
   of Store-cities . . . . . 2863<sup>a</sup>  
   of Zoan . . . . . 3153<sup>a</sup> (Conder)
- Rabbah . . . . . 2520<sup>b</sup> (Ewing)  
   Ammonite capital . . . . 2520<sup>b</sup>  
   Modern site . . . . . 2521<sup>b</sup>  
   References to . . . . . 2521<sup>a</sup>
- Rabbi . . . . . 2522<sup>a</sup> (Pollard)  
   of Rabboni . . . . . 2522<sup>a</sup>  
   of Talmud . . . . . 2904<sup>b</sup> (Strack)
- Rabboth . . . . . 2522<sup>a</sup>  
 Rabble . . . . . 2522<sup>a</sup>  
 Rabboni . . . . . 2522<sup>a</sup>  
   of Master . . . . . 2007<sup>b</sup> (W. L. Walker)  
   of Rabbi . . . . . 2522<sup>a</sup> (Pollard)
- Rab-mag . . . . . 2522<sup>a</sup> (Clippinger)  
   of Nergal-sharezer . . . 2134<sup>b</sup>  
   of Rab-saris . . . . . 2522<sup>b</sup> (Clippinger)  
   of Samgar-nebo . . . . . 2674<sup>b</sup> (Wolf)  
   of Zoroastrianism . . . 3157<sup>a</sup> (Easton)
- Rab-saris . . . . . 2522<sup>b</sup> (Clippinger)  
   of Assyria . . . . . 292<sup>b</sup> (Sayce)  
   of Rab-mag . . . . . 2522<sup>a</sup> (Clippinger)  
   of Tartan . . . . . 2917<sup>a</sup> (Eiselen)
- Rabshakch . . . . . 2522<sup>b</sup> (Clippinger)  
   of Tartan . . . . . 2917<sup>a</sup> (Eiselen)
- Raca . . . . . 2523<sup>a</sup> (Edwards)  
   of Rail, Railing, Railer 2525<sup>b</sup> (W. L. Walker)
- Racal . . . . . 2523<sup>a</sup> (N. Isaacs)
- Race  
   of Games . . . . . 1168<sup>b</sup> (Smith)
- Races  
   of Table of Nations . . . 2898<sup>b</sup> (Pinches)
- Rachab (Rahab) . . . . . 2523<sup>b</sup>
- Rachal  
   of Racal . . . . . 2523<sup>a</sup> (N. Isaacs)
- Rachel . . . . . 2523<sup>b</sup> (Press); 449<sup>b</sup> (Mas-  
     terman)  
   Biography . . . . . 2523<sup>b</sup>  
   Character . . . . . 2523<sup>b</sup>  
   of Jacob . . . . . 1550<sup>b</sup> (Boyd)  
   Rachel's tomb . . . . . 2524<sup>a</sup>
- Raddai . . . . . 2524<sup>a</sup>
- Radiant . . . . . 2524<sup>a</sup> (M. O. Evans)
- Raft  
   of Ships and Boats . . . 2774<sup>a</sup> (Nicol)
- Rafter  
   of Gallery . . . . . 1167<sup>a</sup> (N. Isaacs)  
   of House . . . . . 1434<sup>b</sup> (A. C. Dickie)
- Rag . . . . . 2524<sup>b</sup>
- Ragau (Apoc) . . . . . 2524<sup>b</sup>
- Rages, Ragau (Apoc) . . . 2524<sup>b</sup> (Tisdall)
- Raguel . . . . . 2525<sup>a</sup> (N. Isaacs)  
   of Jethro . . . . . 1674<sup>b</sup> (Crichton)  
   of Relationships, Fam-  
     ily . . . . . 2554<sup>a</sup> (N. and E. D.  
       Isaacs)  
   of Reuel . . . . . 2573<sup>b</sup> (Wolf)
- Raguel (Apoc) . . . . . 2525<sup>a</sup>  
   of Raphael (Apoc) . . . 2532<sup>b</sup> (J. E. H. Thomson)
- Rahab . . . . . 2525<sup>a</sup> (N. Isaacs)  
   of Astronomy . . . . . 300<sup>b</sup> (Maunder)  
   of Faith of . . . . . 1088<sup>a</sup> (Dunelm)
- Raham . . . . . 2525<sup>b</sup>
- Rahel  
   of Rachel . . . . . 2523<sup>b</sup> (Press)
- Raid  
   of War . . . . . 3069<sup>b</sup> (Nicol)
- Rail, Railing, Railer . . . 2525<sup>b</sup> (W. L. Walker)  
   of Raca . . . . . 2523<sup>a</sup> (Edwards)
- Raiment  
   of Dress . . . . . 875<sup>b</sup> (Eager)
- Raiment, Soft . . . . . 2525<sup>b</sup> (Eager)
- Rain . . . . . 2525<sup>b</sup> (Joy)  
   Rainy seasons . . . . . 2526<sup>a</sup>  
   of Seasons . . . . . 2710<sup>b</sup> (Joy)  
   Tables of rainfall . . . . 2526<sup>a</sup>  
   Water supply . . . . . 2525<sup>b</sup>
- Rainbow . . . . . 2527<sup>a</sup> (Joy)
- Raise . . . . . 2527<sup>a</sup> (W. L. Walker)
- Raisin-cakes . . . . . 2527<sup>a</sup>  
   of Raisins . . . . . 2527<sup>a</sup> (Masterman)
- Raisins . . . . . 2527<sup>a</sup> (Masterman)
- Rakem . . . . . 2527<sup>b</sup>  
   of Rekem . . . . . 2553<sup>b</sup> (Wolf)
- Rakkath . . . . . 2527<sup>b</sup> (Ewing)
- Rakkon  
   of Me-jarkon . . . . . 2028<sup>a</sup>
- Ram (animal) . . . . . 2527<sup>b</sup>  
   of Sheep . . . . . 2756<sup>b</sup> (Day)
- Ram (person) . . . . . 2527<sup>b</sup> (Wolf)
- Ram, Battering  
   of Siege . . . . . 2786<sup>a</sup> (Nicol)

- Rama (Ramah) . . . . . 2527<sup>b</sup>  
 Ramah . . . . . 2527<sup>b</sup> (Ewing)  
   cf High Place . . . . . 1390<sup>a</sup> (Easton)  
   cf Mizpah . . . . . 2068<sup>a</sup> (Ewing)  
 Ramah of the South . . . . . 2528<sup>b</sup> (Ewing)  
 Ramath-lehi . . . . . 2528<sup>b</sup> (Ewing)  
   cf Jaw, Jawbone . . . . . 1572<sup>a</sup> (M. O. Evans)  
 Ramath-mizpeh . . . . . 2529<sup>a</sup>  
   cf Mizpah . . . . . 2068<sup>a</sup> (Ewing)  
 Ramathaim . . . . . 2529<sup>a</sup>  
 Ramathaim-zophim  
   cf Ramah . . . . . 2528<sup>a</sup> (Ewing)  
 Ramathite . . . . . 2529<sup>a</sup>  
 Rameses (Raamses) . . . . . 2520<sup>a</sup> (Conder)  
 Ramiyah . . . . . 1389<sup>b</sup>; 2529<sup>a</sup>  
 Ramleh  
   cf Lod, Lydda . . . . . 1909<sup>b</sup> (Ewing)  
 Ramman . . . . . 372<sup>a</sup> (Rogers)  
 Rammon-nirari III . . . . . 437<sup>b</sup> (Nicol)  
 Ramoth (person) . . . . . 2529<sup>a</sup>  
   cf Jeremoth . . . . . 1591<sup>a</sup>  
 Ramoth (place) . . . . . 2529<sup>a</sup>  
   cf Jarmuth . . . . . 1570<sup>a</sup> (Masterman)  
   cf Remeth . . . . . 2557<sup>a</sup>  
   cf Stones, Precious . . . . . 2856<sup>a</sup> (Fletcher)  
 Ramoth-gilead . . . . . 2529<sup>a</sup> (Ewing)  
   cf Gerasa, Gerasenes . . . . . 1218<sup>a</sup> (Ewing)  
   cf Gilead . . . . . 1229<sup>b</sup> (Ewing)  
   History . . . . . 2529<sup>a</sup>  
   Identification . . . . . 2529<sup>b</sup>  
   cf Mizpah . . . . . 2068<sup>a</sup> (Ewing)  
   cf Ramath-mizpeh . . . . . 2529<sup>a</sup>  
   cf Refuge, Cities of . . . . . 2545<sup>b</sup> (Ewing)  
 Ramoth of the South  
   cf Ramah . . . . . 2528<sup>b</sup> (Ewing)  
 Rampart  
   cf Fortification . . . . . 1136<sup>b</sup> (Nicol)  
 Ram's Horn  
   cf Music . . . . . 2094<sup>b</sup> (Millar)  
 Rams' Skins . . . . . 2530<sup>a</sup>  
   cf Dye, Dyeing . . . . . 883<sup>b</sup> (Patch)  
   cf Tabernacle . . . . . 2887<sup>b</sup> (Caldecott; Orr)  
 Range . . . . . 2530<sup>a</sup> (Easton)  
 Rank . . . . . 2530<sup>a</sup>  
 Ranks . . . . . 2530<sup>a</sup>  
 Ransom . . . . . 2530<sup>a</sup> (M'Caig)  
   cf Mediation, Medi-  
   ator . . . . . 2018<sup>a</sup> (Edwards)  
   OT usage . . . . . 2530<sup>b</sup>  
   cf Redeemer, Redemp-  
   tion . . . . . 2541<sup>a</sup> (McConnell)  
   To whom paid? . . . . . 2532<sup>a</sup>  
 Rape  
   cf Crimes . . . . . 745<sup>b</sup> (Hirsch)  
   cf Punishments . . . . . 2504<sup>b</sup> (Hirsch)  
 Rapha, Raphah . . . . . 2532<sup>b</sup> (Wolf)  
   cf Rephaiah . . . . . 2559<sup>b</sup>  
   cf Rephaim . . . . . 2559<sup>b</sup> (Porter)  
 Raphael (Apoc) . . . . . 2532<sup>b</sup> (J. E. H. Thomson)  
   cf Rages . . . . . 2524<sup>b</sup> (Tisdall)  
 Raphaim (Apoc) . . . . . 2532<sup>b</sup>  
 Raphon . . . . . 2532<sup>b</sup> (Ewing)  
 Raphu . . . . . 2533<sup>a</sup>  
 Rassas . . . . . 2533<sup>a</sup> (S. F. Hunter)  
 Rathumus (Apoc) . . . . . 2533<sup>a</sup>  
   cf Beeltethmus . . . . . 423<sup>b</sup>  
 Raven . . . . . 2533<sup>a</sup> (Stratton-Porter)  
   cf Elijah . . . . . 930<sup>b</sup> (Farr)  
 Raven, Ravin (verb) . . . . . 2533<sup>b</sup>  
 Razis (Apoc) . . . . . 2533<sup>b</sup>  
 Razor . . . . . 2533<sup>b</sup>  
   cf Barber . . . . . 403<sup>a</sup> (Eager)  
   cf Hair . . . . . 1320<sup>a</sup> (Luering)  
 Reading . . . . . 2534<sup>a</sup> (Edwards)  
 Ready . . . . . 2534<sup>a</sup>  
 Reaiah (Haroeh) . . . . . 2534<sup>a</sup>  
   cf Joel . . . . . 1688<sup>a</sup> (J. Robertson)  
 Reaping . . . . . 2534<sup>a</sup> (Patch)  
   cf Agriculture . . . . . 75<sup>b</sup> (Patch)  
   cf Gleaning . . . . . 1234<sup>b</sup> (Patch)  
   cf Mowing, Mown  
   Grass . . . . . 2093<sup>a</sup> (M. O. Evans)  
   cf Sickle . . . . . 2784<sup>a</sup> (Patch)  
 Rearward . . . . . 2534<sup>b</sup>  
   cf Dan, Tribe of . . . . . 781<sup>b</sup> (Ewing)  
   cf War . . . . . 3069<sup>b</sup> (Nicol)  
 Reason, Reasonable,  
   Reasoning . . . . . 2534<sup>b</sup> (W. L. Walker)  
 Reba . . . . . 2534<sup>b</sup>  
 Rebekah . . . . . 2534<sup>b</sup> (Boyd)  
   cf Jacob . . . . . 1550<sup>a</sup> (Boyd)  
 Rebellion  
   cf Transgression . . . . . 3006<sup>b</sup> (Dungan)  
 Rebuke . . . . . 2535<sup>a</sup> (W. L. Walker)  
 Recah . . . . . 2535<sup>b</sup>  
 Receipt of Custom  
   cf Custom . . . . . 769<sup>a</sup> (Betteridge)  
 Receiver . . . . . 2535<sup>b</sup>  
 Rechab, Rechabites . . . . . 2535<sup>b</sup> (Mack)  
   cf Jehonadab . . . . . 1580<sup>a</sup> (Roberts)  
   cf Kenites . . . . . 1792<sup>a</sup> (Ewing)  
   cf Nazirite . . . . . 2124<sup>a</sup> (Christie)  
 Rechah  
   cf Recah . . . . . 2535<sup>b</sup>  
 Reclining  
   cf Meals . . . . . 2013<sup>b</sup> (Eager)  
   cf Triclinium . . . . . 3011<sup>a</sup> (N. Isaacs)  
 Reconcile, Reconcilia-  
   tion . . . . . 2536<sup>a</sup> (M'Caig)  
   cf Atonement, Day of . . . . . 324<sup>b</sup> (Möller)  
   Biblical teaching . . . . . 2536<sup>b</sup>  
   cf Mediation, Medi-  
   ator . . . . . 2018<sup>a</sup> (Edwards)  
   cf Propitiation . . . . . 2467<sup>a</sup> (Carver)  
   cf Sacrifice . . . . . 2655<sup>a</sup> (Williams)  
   Terms . . . . . 2536<sup>a</sup>  
   cf Wrath . . . . . 3113<sup>a</sup> (W. Evans)  
 Record . . . . . 2538<sup>a</sup>  
 Recorder . . . . . 2538<sup>a</sup>  
 Recover . . . . . 2538<sup>a</sup> (W. L. Walker)  
 Recruiting System, Ro-  
   man . . . . . 258<sup>a</sup> (Allen)

- Red  
 of Colors . . . . . 674<sup>b</sup> (Patch)
- Red Dragon  
 of Revelation of John 2582<sup>b</sup> (Orr)
- Red Heifer . . . . . 1367<sup>b</sup> (Easton)
- Red Horse  
 of Revelation of John 2582<sup>b</sup> (Orr)
- Red Sea . . . . . 2538<sup>b</sup> (Wright)  
 of Egypt . . . . . 911<sup>b</sup> (Petrie)  
 Name . . . . . 2538<sup>b</sup>  
 OT references . . . . . 2539<sup>a</sup>  
 Passage of Israel . . . . . 2539<sup>b</sup>  
 Peculiarities . . . . . 2538<sup>b</sup>  
 of Ships and Boats . . . . . 2774<sup>a</sup> (Nicol)
- Redeemer, Redemption. 2541<sup>a</sup> (McConnell)  
 of Job, Book of . . . . . 1683<sup>b</sup> (Genung)  
 Life in individual . . . . . 2541<sup>a</sup>  
 of Mediation, Media-  
 tor . . . . . 2018<sup>a</sup> (Edwards)  
 Moral implications . . . . . 2542<sup>b</sup>  
 Moralizing of the idea 2541<sup>a</sup>  
 of Paul, Theology of . . . . . 2291<sup>b</sup> (Easton)  
 of Ransom . . . . . 2530<sup>a</sup> (M'Caig)  
 of Sacrifice, NT . . . . . 2653<sup>a</sup> (Williams)  
 of Sin . . . . . 2801<sup>a</sup> (McConnell)  
 Social process . . . . . 2542<sup>a</sup>  
 Son of God, the . . . . . 2543<sup>a</sup>
- Redness of Eyes  
 of Drunkenness . . . . . 880<sup>b</sup> (Edwards)
- Redound . . . . . 2544<sup>a</sup>
- Reed . . . . . 2544<sup>a</sup> (Masterman)  
 of Flag . . . . . 1117<sup>b</sup>  
 of Meadow . . . . . 2013<sup>a</sup> (Day)  
 of Papyrus . . . . . 2238<sup>b</sup> (Goodspeed)  
 of Pool . . . . . 2419<sup>b</sup> (Day)  
 of Rush . . . . . 2627<sup>b</sup> (Masterman)  
 of Tools . . . . . 2999<sup>a</sup> (Easton)
- Reed-grass  
 of Flag . . . . . 1117<sup>b</sup>  
 of Reed . . . . . 2544<sup>a</sup> (Masterman)
- Reed, Measuring . . . . . 2545<sup>a</sup> (Orr)  
 of Cubit . . . . . 765<sup>a</sup> (Porter)  
 of Weights and Meas-  
 ures . . . . . 3079<sup>a</sup> (Porter)
- Reelaiah (Raamiah) . . . . . 2545<sup>a</sup>; 2520<sup>a</sup>
- Reelias, Reelius (Apoc). 2545<sup>a</sup>
- Reesaias  
 of Resaias . . . . . 2561<sup>a</sup>
- Refiner, Refining . . . . . 2545<sup>a</sup> (Patch)  
 of Founder . . . . . 1141<sup>b</sup>  
 of Lead . . . . . 1861<sup>a</sup> (Patch)  
 of Metallurgy . . . . . 2044<sup>a</sup> (Patch)
- Reform . . . . . 2545<sup>b</sup>
- Reformation . . . . . 2545<sup>b</sup>; 1019<sup>a</sup> (Alexander)
- Reformation Creeds . . . . . 743<sup>b</sup> (Alexander)
- Reformation, Principles  
 of . . . . . 338<sup>a</sup> (Rees)
- Refresh, Refreshing . . . . . 2545<sup>b</sup> (W. L. Walker)
- Refuge . . . . . 2545<sup>b</sup>
- Refuge, Cities of . . . . . 2545<sup>b</sup> (Ewing)  
 of Bezer . . . . . 459<sup>b</sup>  
 of Goel . . . . . 1272<sup>b</sup> (Breslich)
- Refuge, Cities of—*continued*  
 of Golan . . . . . 1273<sup>b</sup> (Ewing)  
 of Hebron . . . . . 1365<sup>a</sup> (Masterman)  
 of Homicide . . . . . 1418<sup>a</sup> (Levertoff)  
 of Kedesh . . . . . 1790<sup>b</sup> (Ewing)  
 of Ramoth-gilead . . . . . 2529<sup>a</sup> (Ewing)  
 of Shechem . . . . . 2755<sup>a</sup> (Ewing)
- Refuse . . . . . 2546<sup>a</sup>
- Refute . . . . . 2546<sup>a</sup> (Edwards)
- Regem . . . . . 2546<sup>b</sup>
- Regem-melech . . . . . 2546<sup>b</sup>  
 of Sharezer . . . . . 2750<sup>a</sup> (Eiselen)
- Regeneration . . . . . 2546<sup>b</sup> (Nuelsen)  
 Apostolic teaching . . . . . 2548<sup>a</sup>  
 of Conversion . . . . . 706<sup>b</sup> (Nuelsen)  
 of Eschatology of the  
 NT . . . . . 979<sup>b</sup> (Vos)  
 of Johannine Theology 1703<sup>b</sup> (Law)  
 Later development . . . . . 2549<sup>b</sup>  
 of Man, New . . . . . 1975<sup>a</sup> (Webb)  
 OT doctrine . . . . . 2547<sup>a</sup>  
 Present significance . . . . . 2549<sup>b</sup>  
 of Seed . . . . . 2712<sup>b</sup> (Easton)  
 Teaching of Jesus . . . . . 2547<sup>b</sup>  
 Term explained . . . . . 2546<sup>b</sup>
- Regeneration, Baptismal 397<sup>a</sup> (Orr; Bishop; Dau)
- Region . . . . . 2550<sup>b</sup>  
 of Galatia . . . . . 1154<sup>a</sup> (Ramsay)
- Register  
 of Genealogy . . . . . 1183<sup>b</sup> (Crannell)  
 of Quirinius . . . . . 645<sup>a</sup> (Armstrong)
- Rehabiah . . . . . 2550<sup>b</sup>
- Rehearse . . . . . 2550<sup>b</sup>
- Rehob . . . . . 2550<sup>b</sup> (Christie)
- Rehoboam . . . . . 2551<sup>a</sup> (Mosiman)  
 Division of kingdom . . . . . 2551<sup>a</sup>  
 of Israel, History of the  
 People . . . . . 1521<sup>a</sup> (Orelli)  
 of Jeroboam I . . . . . 1593<sup>b</sup> (Mosiman)  
 of Roboam . . . . . 2596<sup>a</sup>  
 of Shishak . . . . . 2778<sup>a</sup> (Nicol)  
 Shishak's invasion . . . . . 2552<sup>a</sup>
- Rehoboth . . . . . 2552<sup>a</sup> (Masterman)  
 of Negeb . . . . . 2130<sup>a</sup> (Masterman)  
 of Sitnah . . . . . 2813<sup>a</sup>
- Rehoboth-ir . . . . . 2552<sup>b</sup> (Pinches)  
 of Nineveh . . . . . 2147<sup>b</sup> (Pinches)
- Rehoboth by the River . . . . . 2552<sup>b</sup> (Ewing)
- Rehum . . . . . 2552<sup>b</sup> (Stearns)  
 of Harim . . . . . 1339<sup>a</sup> (Stearns)  
 of Nehum . . . . . 2132<sup>a</sup>  
 of Roimus (Apoc) . . . . . 2597<sup>a</sup>  
 of Shimshai . . . . . 2771<sup>a</sup> (Wolf)
- Rei . . . . . 2553<sup>a</sup> (Wolf)
- Reign . . . . . 2553<sup>a</sup> (Baur)  
 of King . . . . . 1799<sup>a</sup> (Press)
- Reins . . . . . 2553<sup>b</sup> (Luering)  
 of Kidneys . . . . . 1797<sup>b</sup> (Easton)
- Rekem . . . . . 2553<sup>b</sup> (Wolf)  
 of Rakem . . . . . 2527<sup>b</sup>
- Relationships, Family . . . . . 2554<sup>a</sup> (N. and E. D,  
 Isaacs)

- Relationships, Family—*continued*  
 Brothers and sisters . . . 2555<sup>a</sup>  
 Father-in-law, etc. . . . 2556<sup>a</sup>  
 cf Hospitality . . . . . 1432<sup>a</sup> (Easton)  
 Husband and wife . . . 2555<sup>a</sup>  
 Other domestic ties . . . 2556<sup>a</sup>  
 Parents and children . . . 2554<sup>a</sup>  
 cf Queen Mother . . . . 2513<sup>b</sup> (Baur)  
 cf Raguel . . . . . 2525<sup>a</sup> (N. Isaacs)  
 cf Sister . . . . . 2813<sup>a</sup> (Pollard)  
 cf Slavery . . . . . 2815<sup>a</sup> (Raffety)  
 cf Son, Sons . . . . . 2826<sup>a</sup> (Bettridge)  
 cf Spouse . . . . . 2846<sup>b</sup>  
 Uncles, etc. . . . . 2555<sup>a</sup>  
 Release . . . . . 2556<sup>b</sup>  
 cf Jubilee Year . . . . . 1756<sup>a</sup> (Baur)  
 Religion . . . . . 2556<sup>b</sup> (Easton)  
 cf Babylonia and Assyria, Religion of . . . 368<sup>b</sup> (Rogers)  
 cf Superstition . . . . . 2871<sup>a</sup> (Doolan)  
 Theories of origin and growth . . . . . 692<sup>a</sup> (Tisdall)  
 Universality of . . . . . 692<sup>a</sup> (Tisdall)  
 Religion, Comparative . . . 691<sup>b</sup> (Tisdall)  
 Religion of Israel . . . . . 1513<sup>b</sup> (Orelli)  
 Religion, Science of . . . . 691<sup>b</sup> (Tisdall)  
 Remainder . . . . . 2557<sup>a</sup>  
 Remaliah . . . . . 2557<sup>a</sup>  
 Remember, Remembrance . . . . . 2557<sup>a</sup> (W. L. Walker)  
 Remeth . . . . . 2557<sup>a</sup>  
 cf Jarmuth . . . . . 1570<sup>a</sup> (Masterman)  
 cf Ramoth (place) . . . . . 2529<sup>a</sup>  
 Remission of Sins . . . . . 2557<sup>b</sup> (Jacobs)  
 cf Absolution . . . . . 24<sup>a</sup> (Jacobs)  
 cf Forgiveness . . . . . 1132<sup>b</sup> (Morro)  
 cf Sacrifice, NT . . . . . 2653<sup>b</sup> (Williams)  
 Remmon . . . . . 2557<sup>b</sup>  
 cf Rimmon (place) . . . . . 2593<sup>b</sup> (Masterman)  
 Remmon-methoar . . . . . 2557<sup>b</sup>  
 cf Rimmon (place) . . . . . 2593<sup>b</sup> (Masterman)  
 Remnant . . . . . 2557<sup>b</sup> (W. L. Walker)  
 cf Rest . . . . . 2561<sup>b</sup> (W. L. Walker)  
 Removing Landmarks  
 cf Landmark . . . . . 1826<sup>b</sup>  
 Remphan  
 cf Rephan . . . . . 2560<sup>a</sup>  
 Rend Asunder . . . . . 316<sup>b</sup> (S. F. Hunter)  
 Rending of Garments  
 cf Burial . . . . . 529<sup>a</sup> (Eager)  
 cf Dress . . . . . 875<sup>b</sup> (Eager)  
 Renew . . . . . 2557<sup>b</sup> (Gerberding)  
 Repair . . . . . 2558<sup>a</sup>  
 Repentance . . . . . 2558<sup>a</sup> (DeMent)  
 NT terms . . . . . 2558<sup>b</sup>  
 OT terms . . . . . 2558<sup>a</sup>  
 Psychological elements . . . 2559<sup>a</sup>  
 cf Sin . . . . . 2801<sup>b</sup> (McConnell)  
 Repetitions . . . . . 2559<sup>b</sup> (Easton)  
 cf Magic, Magician . . . . 1964<sup>b</sup> (T. W. Davies)  
 cf Prayer . . . . . 2430<sup>a</sup> (Lambert)
- Rephael (Raphael) . . . . . 2559<sup>b</sup>  
 Rephah . . . . . 2559<sup>b</sup>  
 Rephaiah . . . . . 2559<sup>b</sup>  
 cf Rapha, Raphah . . . . . 2532<sup>b</sup> (Wolf)  
 Rephaim . . . . . 2559<sup>b</sup> (Porter)  
 cf Og . . . . . 2180<sup>b</sup> (Orr)  
 cf Rapha, Raphah . . . . . 2532<sup>b</sup> (Wolf)  
 cf Sons of God (OT) . . . . 2835<sup>a</sup> (Crichton)  
 cf Titans . . . . . 2987<sup>a</sup>  
 cf Zamzummim . . . . . 3132<sup>a</sup>  
 Rephaim, Vale of . . . . . 2560<sup>a</sup> (Ewing)  
 Rephan . . . . . 2560<sup>a</sup>  
 cf Astrology . . . . . 295<sup>b</sup> (Maunder)  
 cf Chiun . . . . . 612<sup>a</sup> (Margolis)  
 Rephidim . . . . . 2560<sup>a</sup> (Ewing)  
 cf Massah and Meribah . . . . . 2007<sup>a</sup> (Ewing)  
 Reprobate . . . . . 2560<sup>a</sup> (Vos)  
 Reproof, Reprove . . . . . 2560<sup>b</sup> (Easton)  
 Reptile . . . . . 2561<sup>a</sup>  
 cf Leviathan . . . . . 1868<sup>b</sup> (Day)  
 cf Lizard . . . . . 1906<sup>a</sup> (Day)  
 cf Serpent . . . . . 2736<sup>a</sup> (Day)  
 cf Tortoise . . . . . 2999<sup>b</sup> (Day)  
 Reputation . . . . . 2561<sup>a</sup>  
 cf Kenosis . . . . . 1792<sup>a</sup> (Easton)  
 Require . . . . . 2561<sup>a</sup>  
 Rereward  
 cf Rearward . . . . . 2534<sup>b</sup>  
 Resaias (Reelaiah) . . . . . 2561<sup>a</sup>; 2545<sup>a</sup>  
 Resen . . . . . 2561<sup>a</sup> (Pinches)  
 cf Calah . . . . . 539<sup>b</sup> (Pinches)  
 cf Nineveh . . . . . 2149<sup>a</sup> (Pinches)  
 Reservoir . . . . . 2561<sup>a</sup>  
 cf Cistern . . . . . 657<sup>b</sup> (A. C. Dickie)  
 cf Ditch . . . . . 859<sup>b</sup> (Clippinger)  
 cf Pool . . . . . 2419<sup>b</sup> (Day)  
 Resh . . . . . 2561<sup>a</sup>  
 cf Alphabet . . . . . 103<sup>b</sup> (Richardson)  
 Resheph . . . . . 2561<sup>b</sup>  
 Residue  
 cf Remnant . . . . . 2557<sup>b</sup> (W. L. Walker)  
 Respect of Persons . . . . . 2561<sup>b</sup> (Easton)  
 cf Accept . . . . . 27<sup>b</sup> (Pratt)  
 Rest . . . . . 2561<sup>b</sup> (W. L. Walker)  
 cf Remnant . . . . . 2557<sup>b</sup> (W. L. Walker)  
 cf Sabbath . . . . . 2629<sup>b</sup> (Sampey)  
 Restitution, Restoration  
 cf Punishments . . . . . 2504<sup>b</sup> (Hirsch)  
 Restoration . . . . . 2561<sup>b</sup> (Miller)  
 cf Punishment, Everlasting . . . . . 2501<sup>b</sup> (Orr)  
 Resurrection . . . . . 2562<sup>a</sup> (Easton); 614<sup>b</sup> (Bevan)  
 Apostolic teaching . . . . . 2564<sup>a</sup>  
 cf Body . . . . . 491<sup>b</sup> (Hirsch; Marais; Pratt)  
 cf Eschatology, NT . . . . . 979<sup>b</sup> (Vos)  
 cf Eschatology, OT . . . . . 972<sup>a</sup> (Orr)  
 cf Flesh . . . . . 1118<sup>b</sup> (Luering)  
 cf Heart . . . . . 1350<sup>b</sup> (Marais)  
 cf Immortality . . . . . 1461<sup>a</sup> (Orr)

Resurrection—*continued*

- Israel and immortality 2562<sup>b</sup>  
 of Jesus Christ . . . . . 1664<sup>b</sup> (Orr)  
 of Job, Book of . . . . . 1679<sup>b</sup> (Genung)  
 of Johannine Theology 1705<sup>b</sup> (Law)  
 of Last Judgment . . . . . 1777<sup>b</sup> (Easton)  
 of Lazarus . . . . . 1860<sup>a</sup> (Trever)  
 of Maccabees, Books  
   of . . . . . 1949<sup>b</sup> (T. W. Davies)  
   of ideas . . . . . 2563<sup>a</sup>  
 of Parousia . . . . . 2249<sup>a</sup> (Easton)  
 of Psychology . . . . . 2494<sup>b</sup> (Marais)  
 of Salvation . . . . . 2670<sup>a</sup> (Easton)  
 of Sheol . . . . . 2761<sup>a</sup> (Orr)  
 of Soul . . . . . 2837<sup>a</sup> (Marais)  
 of Spirit . . . . . 2841<sup>b</sup> (Marais)  
 Teaching of Christ . . . . . 2563<sup>b</sup>  
 of Witchcraft . . . . . 3097<sup>a</sup> (T. W. Davies)  
 of Zoroastrianism . . . . . 3157<sup>a</sup> (Easton)
- Resurrection, Gospel of  
   the  
   of Apocryphal Gospels. 195<sup>a</sup> (Hutchison)
- Resurrection of Jesus  
   Christ, The . . . . . 2565<sup>b</sup> (Thomas)  
   Effect on disciples . . . . . 2567<sup>a</sup>  
   Empty grave, the . . . . . 2566<sup>a</sup>  
   Gospel record . . . . . 2568<sup>a</sup>  
   Paul's witness . . . . . 2567<sup>b</sup>  
   Primitive church . . . . . 2567<sup>b</sup>  
   Proofs . . . . . 2565<sup>b</sup>  
   Theology of . . . . . 2569<sup>b</sup>
- Retain . . . . . 2569<sup>b</sup>
- Retaliation  
   of Law in the NT . . . . . 1844<sup>a</sup> (M'Caig)  
   of Punishments . . . . . 2504<sup>b</sup> (Hirsch)  
   of Retribution . . . . . 2570<sup>a</sup> (M'Caig)
- Retention of Sins . . . . . 2569<sup>b</sup> (Jacobs)
- Retribution . . . . . 2570<sup>a</sup> (M'Caig)  
   Biblical terms . . . . . 2571<sup>a</sup>  
   of Immortality . . . . . 1461<sup>a</sup> (Orr)  
   of Judgment . . . . . 1777<sup>a</sup> (Jacobs)  
   Moral sense . . . . . 2571<sup>b</sup>  
   Nature of . . . . . 2570<sup>b</sup>  
   of Punishment, Ever-  
     lasting . . . . . 2502<sup>a</sup> (Orr)  
   of Sacrifice, NT . . . . . 2655<sup>a</sup> (Williams)  
   of Sheol . . . . . 2761<sup>a</sup> (Orr)  
   Wrath and grace . . . . . 2570<sup>a</sup>  
     of Wrath . . . . . 3113<sup>a</sup> (W. Evans)
- Reu . . . . . 2572<sup>a</sup>
- Reuben . . . . . 2572<sup>a</sup> (Ewing)  
   Jacob's eldest son . . . . . 2572<sup>a</sup>  
   of Names, Proper . . . . . 2116<sup>b</sup> (Davis)  
   of Numbers, Book of . . . . . 2163<sup>a</sup> (Whitelaw)  
   Tribal history . . . . . 2572<sup>b</sup>
- Reubenites . . . . . 2573<sup>b</sup>
- Reuel . . . . . 2573<sup>b</sup> (Wolf)  
   of Hobab . . . . . 1402<sup>b</sup> (Cotton)  
   of Jethro . . . . . 1674<sup>a</sup> (Crichton)  
   of Raguel . . . . . 2525<sup>a</sup> (N. Isaacs)
- Reumah . . . . . 2573<sup>b</sup>
- Revelation . . . . . 2573<sup>b</sup> (Warfield)  
   of Accommodation . . . . . 32<sup>b</sup> (Sweet)  
   Biblical terms . . . . . 2580<sup>b</sup>  
   Christ as . . . . . 2580<sup>b</sup>  
   General and special . . . . . 2574<sup>b</sup>  
   Inspiration . . . . . 2580<sup>a</sup>  
     of Inspiration . . . . . 1473<sup>a</sup> (Warfield)  
   of John, the Apostle . . . . . 1706<sup>b</sup> (Iverach)  
   Modes of . . . . . 2577<sup>a</sup>  
   Process of . . . . . 2576<sup>a</sup>  
   Prophecy . . . . . 2578<sup>a</sup>  
     of Prophecy . . . . . 2459<sup>b</sup> (Orelli)  
   Scriptures . . . . . 2582<sup>a</sup>  
   of See . . . . . 2712<sup>b</sup> (M. O. Evans)  
   Supernatural character 2573<sup>b</sup>
- Revelation (Doctrine of)  
   Through spirit . . . . . 1667<sup>a</sup> (Orr)
- Revelation of John . . . . . 2582<sup>b</sup> (Orr)  
   Analysis of . . . . . 2585<sup>a</sup>  
   Antichrist . . . . . 155<sup>a</sup> (J. E. H. Thomson)  
   of Apocalyptic Lit-  
     erature . . . . . 161<sup>b</sup> (J. E. H. Thomson)  
   Canonicity and author-  
     ity . . . . . 2583<sup>a</sup>  
   Date and unity . . . . . 2584<sup>a</sup>  
   of Horse, Black . . . . . 1423<sup>b</sup>  
   of Horse, Red . . . . . 1423<sup>b</sup>  
   of Horse, White . . . . . 1424<sup>a</sup>  
   Interpretation . . . . . 2586<sup>a</sup>  
   of Jerusalem, New . . . . . 1621<sup>b</sup> (Vos)  
   of John, Gospel of . . . . . 1720<sup>a</sup> (Iverach)  
   of Man of Sin . . . . . 1976<sup>b</sup> (Orr)  
   of Patmos . . . . . 2263<sup>b</sup> (Harry)  
   Theology of . . . . . 2587<sup>a</sup>  
   Title and character . . . . . 2582<sup>b</sup>
- Revellings . . . . . 2587<sup>a</sup> (Gerberding)
- Revenge, Revenger . . . . . 2587<sup>a</sup> (Breslich)  
   of Avenge, Avenger . . . . . 340<sup>a</sup> (Breslich)  
   of Blood . . . . . 488<sup>b</sup> (Clippinger)  
   of Goel . . . . . 1272<sup>b</sup> (Breslich)
- Revenue . . . . . 2587<sup>a</sup>
- Reverence . . . . . 2587<sup>b</sup> (Forrester)
- Revile  
   of Crimes . . . . . 745<sup>b</sup> (Hirsch)  
   of Punishments . . . . . 2504<sup>b</sup> (Hirsch)
- Revised Version . . . . . 469<sup>b</sup> (Orr)
- Revive, Reviving . . . . . 2587<sup>b</sup> (W. L. Walker)
- Reward . . . . . 2587<sup>b</sup>
- Rezeph . . . . . 2588<sup>a</sup> (Pinches)
- Rezia  
   of Rizia . . . . . 2595<sup>a</sup>
- Rezin . . . . . 2588<sup>a</sup> (Nicol)  
   Rezin, Sons of . . . . . 2588<sup>b</sup> (Nicol)  
   Rezon . . . . . 2588<sup>b</sup> (Nicol)  
   Rhegium . . . . . 2588<sup>b</sup> (Allen)
- Rhesa . . . . . 2588<sup>b</sup>
- Rhinoceros . . . . . 2589<sup>a</sup>  
   of Unicorn . . . . . 3037<sup>b</sup>
- Rhoda . . . . . 2589<sup>a</sup> (S. F. Hunter)
- Rhodes . . . . . 2589<sup>a</sup> (Harry)  
   History . . . . . 2598<sup>b</sup>



- Rhodes—*continued*  
 Location . . . . . 2589<sup>a</sup>  
 cf Rodanim . . . . . 2597<sup>a</sup>  
 Rhodocus (Apoc) . . . . . 2590<sup>a</sup> (Luering)  
 Rib . . . . . 2590<sup>a</sup> (Luering)  
 Ribai . . . . . 2590<sup>a</sup>  
 Ribband . . . . . 2590<sup>a</sup>  
 cf Color . . . . . 674<sup>b</sup> (Patch)  
 cf Cord . . . . . 709<sup>b</sup> (Eager)  
 Riblah . . . . . 2590<sup>a</sup> (Christie)  
 Riches . . . . . 2590<sup>b</sup> (Forrester)  
 cf Mammon . . . . . 1972<sup>b</sup> (Miller)  
 cf Treasure . . . . . 3007<sup>b</sup> (Raffety)  
 cf Wealth . . . . . 3076<sup>a</sup> (W. Evans)  
 Rid, Riddance . . . . . 2590<sup>b</sup>  
 Riddle  
 cf Games . . . . . 1170<sup>b</sup> (Smith)  
 Rie . . . . . 2591<sup>a</sup>  
 cf Spelt . . . . . 2840<sup>a</sup>  
 Right . . . . . 2591<sup>a</sup> (W. L. Walker)  
 cf Truth . . . . . 3025<sup>a</sup> (Carver)  
 Righteousness . . . . . 2591<sup>a</sup> (McConnell); 1027<sup>a</sup>  
 (Stalker)  
 Character of God . . . . . 2592<sup>a</sup>  
 Double aspect . . . . . 2591<sup>a</sup>  
 cf Faithful, Faithful-  
 ness . . . . . 1088<sup>b</sup> (Hodge)  
 cf Justice . . . . . 1781<sup>b</sup> (Rall)  
 cf Philosophy . . . . . 2384<sup>b</sup> (Rees)  
 cf Sermon on the  
 Mount . . . . . 2734<sup>b</sup> (Miller)  
 Social custom . . . . . 2591<sup>b</sup>  
 Rig-veda  
 cf Persian Religion  
 (Ancient) . . . . . 2331<sup>b</sup> (Tisdall)  
 Rim  
 cf Ring . . . . . 2594<sup>a</sup> (Crannell)  
 Rimmon (god) . . . . . 2594<sup>a</sup> (N. Isaacs)  
 cf Gods . . . . . 1271<sup>a</sup> (Reeve)  
 cf Hadadrimmon . . . . . 1314<sup>a</sup> (Ewing)  
 cf Tabrimmon . . . . . 2902<sup>a</sup>  
 Rimmon (person) . . . . . 2594<sup>a</sup> (N. Isaacs)  
 Rimmon (place) . . . . . 2593<sup>b</sup> (Masterman)  
 cf Dimnah . . . . . 849<sup>a</sup>  
 cf En-rimmon . . . . . 953<sup>b</sup> (Masterman)  
 cf Remmon-methoar . . . . . 2557<sup>b</sup>  
 Rimmon-nirari  
 Western campaigns of 570<sup>b</sup> (Nicol)  
 Rimmon-perez . . . . . 2594<sup>a</sup>  
 cf Wanderings of Is-  
 rael . . . . . 3064<sup>a</sup> (Conder)  
 Rimmon, Rock of  
 cf Rimmon (place) . . . . . 2593<sup>b</sup> (Masterman)  
 Rimmonah, Rimmono  
 cf Rimmon (place) . . . . . 2593<sup>b</sup> (Masterman)  
 Ring . . . . . 2594<sup>a</sup> (Crannell)  
 cf Earring . . . . . 887<sup>a</sup> (Eager)  
 cf Seal . . . . . 2708<sup>b</sup> (Edwards)  
 Ringleader . . . . . 2594<sup>b</sup>  
 Ringstreaked . . . . . 2594<sup>b</sup>  
 Rinnah . . . . . 2594<sup>b</sup>  
 Riot . . . . . 2594<sup>b</sup> (Easton)  
 Riphath . . . . . 2594<sup>b</sup>  
 cf Diphath . . . . . 851<sup>a</sup>  
 Rising . . . . . 2594<sup>b</sup>  
 cf Leprosy . . . . . 1867<sup>a</sup> (Macalister)  
 Rissah . . . . . 2594<sup>b</sup>  
 cf Wanderings of Is-  
 rael . . . . . 3064<sup>a</sup> (Conder)  
 Rites . . . . . 693<sup>b</sup> (Tisdall)  
 Rithmah . . . . . 2595<sup>a</sup>  
 cf Wanderings of Is-  
 rael . . . . . 3064<sup>a</sup> (Conder)  
 River . . . . . 2595<sup>a</sup> (Day)  
 cf Brook . . . . . 523<sup>b</sup> (Day)  
 cf Stream . . . . . 2866<sup>b</sup> (Day)  
 cf Valley . . . . . 3045<sup>a</sup> (Day)  
 cf Watercourse . . . . . 3074<sup>b</sup> (Day)  
 River of Egypt  
 cf Brook of Egypt . . . . . 523<sup>b</sup> (Kyle)  
 cf Nile . . . . . 2145<sup>a</sup> (Kyle)  
 River, the (Great)  
 cf Euphrates . . . . . 1038<sup>b</sup> (Wright)  
 Rivers of Eden  
 cf Eden . . . . . 897<sup>b</sup> (Wright)  
 Rizia . . . . . 2595<sup>a</sup>  
 Rizpah . . . . . 2595<sup>a</sup> (Wallace)  
 cf Mephibosheth . . . . . 2033<sup>b</sup> (Wallace)  
 cf Merab . . . . . 2034<sup>a</sup> (Wallace)  
 Road (Inroad) . . . . . 2595<sup>b</sup>  
 cf War, Warfare . . . . . 3069<sup>b</sup> (Nicol)  
 Road (Way)  
 cf Roman Empire and  
 Christianity . . . . . 2598<sup>a</sup> (Angus)  
 cf Way . . . . . 3075<sup>b</sup> (Morro)  
 Roast  
 cf Food . . . . . 1121<sup>b</sup> (Eager)  
 Robber, Robbery . . . . . 2595<sup>b</sup> (Easton); 747<sup>b</sup>  
 (Hirsch)  
 cf Grasp . . . . . 1293<sup>a</sup> (Miller)  
 cf Thief . . . . . 2972<sup>a</sup> (Easton)  
 Robbers of Temples . . . . . 2595<sup>b</sup>  
 cf Lysimachus (Apoc) . . . . . 1944<sup>a</sup> (Hutchison)  
 Robe  
 cf Dress . . . . . 875<sup>b</sup> (Eager)  
 cf Priests and Levites . . . . . 2452<sup>a</sup> (Wiener)  
 Robinson's Arch  
 cf Jerusalem . . . . . 1613<sup>a</sup> (Masterman)  
 Roboam (Rehoboam) . . . . . 2596<sup>a</sup>  
 Rock . . . . . 2596<sup>a</sup> (Day)  
 cf Crag . . . . . 737<sup>a</sup> (Day)  
 cf Flint . . . . . 1119<sup>b</sup> (Day)  
 Jesus' reference to  
 Peter and the . . . . . 1648<sup>a</sup> (Orr)  
 cf Keys, Power of . . . . . 1794<sup>a</sup> (Carver)  
 cf Lime . . . . . 1893<sup>b</sup> (Day)  
 cf Sand . . . . . 2688<sup>b</sup> (Day)  
 cf Spiritual Drink . . . . . 2843<sup>a</sup>  
 cf Stone, Stones . . . . . 2856<sup>a</sup> (Day)  
 Rock of Ages . . . . . 71<sup>b</sup>  
 cf Isaiah . . . . . 1497<sup>b</sup> (Robinson)  
 Rock-badger . . . . . 2596<sup>b</sup>  
 cf Coney . . . . . 698<sup>b</sup> (Day)

- Rod . . . . . 2596<sup>b</sup> (Orr)  
 Of Aaron . . . . . 2<sup>a</sup> (Mack)  
 Of almond . . . . . 100<sup>b</sup> (Masterman)  
 of Armor, Arms . . . . . 251<sup>a</sup> (Nicol)  
 of Staves . . . . . 2850<sup>a</sup> (Caldecott)
- Rodanim . . . . . 2597<sup>a</sup>  
 of Dodanim . . . . . 867<sup>b</sup>  
 of Rhodes . . . . . 2589<sup>a</sup> (Harry)
- Roe, Roebuck . . . . . 2597<sup>a</sup> (Day)  
 of Deer . . . . . 817<sup>a</sup> (Day)  
 of Gazelle . . . . . 1179<sup>a</sup> (Day)
- Rogelim . . . . . 2597<sup>a</sup>
- Rohgah . . . . . 2597<sup>a</sup>
- Roimus (Apoc) . . . . . 2597<sup>a</sup>  
 of Nehum . . . . . 2132<sup>a</sup>  
 of Rehum . . . . . 2552<sup>b</sup> (Stearns)
- Roll (Scroll) . . . . . 2597<sup>a</sup> (Richardson)  
 of Tablet . . . . . 2900<sup>a</sup> (Richardson)  
 of Volume . . . . . 3058<sup>a</sup>
- Roller . . . . . 2597<sup>b</sup>
- Rolling Thing . . . . . 2597<sup>b</sup>  
 of Chaff . . . . . 588<sup>b</sup> (Patch)  
 of Dust . . . . . 883<sup>a</sup> (Edwards)  
 of Stubble . . . . . 2867<sup>b</sup>
- Romanti-ezer . . . . . 2597<sup>b</sup>  
 of Joshbekashah . . . . . 1743<sup>a</sup>
- Roman, Romans  
 of Citizenship . . . . . 661<sup>a</sup> (Trever)  
 of Rome . . . . . 2618<sup>a</sup> (Allen)
- Roman Army . . . . . 257<sup>a</sup> (Allen)
- Roman Citizenship  
 of Paul, the Apostle . . . . . 2273<sup>b</sup> (A. T. Robertson)
- Roman Empire and  
 Christianity . . . . . 2598<sup>a</sup> (Angus)  
 Attitude toward religion . . . . . 2602<sup>b</sup>  
 of Dispersion . . . . . 855<sup>a</sup> (Nicol)  
 Historical outline . . . . . 2598<sup>a</sup>  
 of Language of the NT 1826<sup>b</sup> (A. T. Robertson)  
 of Latin . . . . . 1840<sup>b</sup> (A. T. Robertson)  
 of Nero . . . . . 2138<sup>a</sup> (Angus)  
 Peace . . . . . 2600<sup>a</sup>  
 of Persecution . . . . . 2323<sup>b</sup> (Rutherford)  
 Preparation for Christianity . . . . . 2600<sup>a</sup>  
 Protection . . . . . 2601<sup>a</sup>  
 Relations between . . . . . 2605<sup>b</sup>  
 of Roman Law . . . . . 2611<sup>b</sup> (Allen)  
 of Rome . . . . . 2618<sup>a</sup> (Allen)  
 of Stoics . . . . . 2854<sup>b</sup> (Rees)  
 Victory of Christianity 2610<sup>b</sup>
- Roman Law . . . . . 2611<sup>b</sup> (Allen)  
 of Citizenship . . . . . 661<sup>a</sup> (Trever)  
 Criminal law . . . . . 2612<sup>b</sup>  
 Private law . . . . . 2612<sup>a</sup>  
 of Roman Empire and  
 Christianity . . . . . 2602<sup>a</sup> (Angus)  
 of Rome . . . . . 2618<sup>a</sup> (Allen)
- Roman Religion  
 of Roman Empire and  
 Christianity . . . . . 2602<sup>b</sup> (Angus)  
 of Rome . . . . . 2618<sup>a</sup> (Allen)
- Romans in Asia Minor . . 281<sup>a</sup> (White); 275<sup>a</sup> (Cald-  
 der); 483<sup>a</sup> (White); 272<sup>b</sup>  
 (Banks)
- Romans, Epistle to the . . 2614<sup>a</sup> (Dunelm)
- Characteristics and  
 teachings . . . . . 2616<sup>b</sup>  
 Date . . . . . 2615<sup>a</sup>  
 Genuineness and integ-  
 rity . . . . . 2614<sup>a</sup>  
 of Hospitality . . . . . 1432<sup>a</sup> (Easton)  
 of Justification . . . . . 1782<sup>b</sup> (Faulkner)  
 Law in . . . . . 1848<sup>a</sup> (M'Caig)  
 Place and destination . . 2615<sup>a</sup>  
 of Propitiation . . . . . 2467<sup>a</sup> (Carver)  
 Relation to Galatians . . 1158<sup>b</sup> (G. G. Findlay)  
 of Sacrifice, NT . . . . . 2655<sup>b</sup> (Williams)
- Rome . . . . . 2618<sup>a</sup> (Allen)  
 of Apocalyptic Liter-  
 ature . . . . . 161<sup>b</sup> (J. E. H. Thomson)  
 of Devout . . . . . 840<sup>a</sup> (M. O. Evans)  
 of Greece, Religion in . . 1297<sup>a</sup> (Fairbanks)  
 Imperial government . . 2620<sup>a</sup>  
 of Italy . . . . . 1542<sup>b</sup> (Allen)  
 of Libertines . . . . . 1881<sup>a</sup> (S. F. Hunter)  
 of Macedonia . . . . . 1957<sup>b</sup> (Tod)  
 Persecution . . . . . 2623<sup>a</sup>  
 of Persecution . . . . . 2325<sup>b</sup> (Rutherford)  
 of Procurator . . . . . 2457<sup>b</sup> (Allen)  
 of Proselytes . . . . . 2467<sup>b</sup> (Levertoff)  
 of Relation to Illyri-  
 cum . . . . . 1449<sup>b</sup> (Tod)
- Republican constitu-  
 tion . . . . . 2618<sup>b</sup>
- of Roman Empire and  
 Christianity . . . . . 2598<sup>a</sup> (Angus)  
 of Roman Law . . . . . 2611<sup>b</sup> (Allen)  
 Roman religion . . . . . 2620<sup>b</sup>  
 Rome and the Chris-  
 tians . . . . . 2622<sup>a</sup>  
 Rome and the Jews . . . 2621<sup>b</sup>  
 of Tax . . . . . 2920<sup>a</sup> (Sweet)  
 of Treaty . . . . . 3008<sup>b</sup> (Nicol)
- Roof  
 of House . . . . . 1434<sup>b</sup> (A. C. Dickie)
- Roof-chamber  
 of House . . . . . 1434<sup>b</sup> (A. C. Dickie)
- Room  
 of House . . . . . 1434<sup>b</sup> (A. C. Dickie)
- Root . . . . . 2623<sup>a</sup>
- Root of David . . . . . 797<sup>b</sup>
- Root of Jesse . . . . . 2623<sup>b</sup>  
 of David, Root of . . . . 797<sup>b</sup>  
 of Jesse . . . . . 1623<sup>a</sup> (Roberts)
- Rope . . . . . 2623<sup>b</sup> (Easton)  
 of Cord . . . . . 709<sup>b</sup> (Eager)  
 of Line . . . . . 1894<sup>a</sup> (Orr)  
 of Ships and Boats . . . 2774<sup>a</sup> (Nicol)
- Rose . . . . . 2623<sup>b</sup> (Masterman)
- Rosh (person) . . . . . 2623<sup>b</sup>
- Rosh (place) . . . . . 2623<sup>b</sup> (Pinches)  
 of Telassar . . . . . 2925<sup>a</sup> (Pinches)
- Rot, Rottenness . . . . . 2624<sup>a</sup>
- Rote . . . . . 2624<sup>a</sup>

- Rower, Rowing  
 cf Ships and Boats. . . . . 2774<sup>a</sup> (Nicol)
- Royal. . . . . 2624<sup>a</sup> (Baur)
- Royal City  
 cf Royal. . . . . 2624<sup>a</sup> (Baur)
- Royal Shekel. . . . . 2758<sup>b</sup>
- Ruby  
 cf Stones, Precious. . . . . 2856<sup>a</sup> (Fletcher)
- Rudder, Rudder-bands. . . . . 2624<sup>b</sup>  
 cf Ships and Boats. . . . . 2774<sup>a</sup> (Nicol)
- Ruddy. . . . . 2624<sup>b</sup>
- Rude. . . . . 2624<sup>b</sup>
- Rudiments. . . . . 2624<sup>b</sup> (Rutherford)  
 cf Elements. . . . . 927<sup>b</sup>  
 cf Principles. . . . . 2455<sup>a</sup>
- Rue. . . . . 2625<sup>b</sup>
- Rufus. . . . . 2625<sup>b</sup> (S. F. Hunter)
- Rug. . . . . 2625<sup>b</sup>
- Ruhamah. . . . . 2625<sup>b</sup>  
 cf Lo-ammi. . . . . 1907<sup>a</sup> (Lees)
- Ruin. . . . . 2625<sup>b</sup> (W. L. Walker)
- Ruler. . . . . 2625<sup>b</sup> (Baur)
- Ruler of the Feast. . . . . 2627<sup>a</sup> (T. Lewis)
- Ruler of the Synagogue  
 cf Ruler. . . . . 2626<sup>b</sup> (Baur)
- Rulers of the City  
 cf Ruler. . . . . 2626<sup>a</sup> (Baur)
- Rumah. . . . . 2627<sup>a</sup> (Ewing)
- Rump. . . . . 2627<sup>a</sup>  
 cf Tail. . . . . 2903<sup>a</sup> (Luering)
- Runagate. . . . . 2627<sup>a</sup>
- Runner  
 cf Forerunner. . . . . 1131<sup>a</sup> (W. Evans)  
 cf Games. . . . . 1168<sup>b</sup> (Smith)
- Rush. . . . . 2627<sup>a</sup> (Masterman)  
 cf Reed. . . . . 2544<sup>a</sup> (Masterman)
- Rust. . . . . 2627<sup>b</sup> (Patch)  
 cf Scum. . . . . 2706<sup>a</sup>
- Ruth. . . . . 2627<sup>b</sup> (Geden); 450<sup>a</sup>  
 (Masterman)  
 cf Boaz. . . . . 491<sup>a</sup> (Roberts)  
 cf Ruth, Book of. . . . . 2628<sup>b</sup> (Geden)
- Ruth, Book of. . . . . 2628<sup>b</sup> (Geden)  
 Authorship and date. . . . . 2628<sup>b</sup>  
 cf Palestine. . . . . 2214<sup>b</sup> (Conder)  
 cf Ruth. . . . . 2627<sup>b</sup> (Geden)
- Rye  
 cf Spelt. . . . . 2840<sup>a</sup>
- Sabachthani  
 cf Eli, Eli, Lama Sabachthani. . . . . 939<sup>a</sup> (Clippinger)
- Sabacó (Sabakon)  
 cf So. . . . . 2820<sup>a</sup> (Nicol)
- Sabaeans. . . . . 2629<sup>a</sup> (Pinches)  
 cf Seba. . . . . 2710<sup>b</sup> (Pinches)  
 cf Sheba. . . . . 2752<sup>b</sup> (Weir)  
 cf Table of Nations. . . . . 2898<sup>b</sup> (Pinches)
- Sabanneus (Zabad). . . . . 2629<sup>b</sup>
- Sabannus. . . . . 2629<sup>b</sup>
- Sabaoth  
 cf God, Names of. . . . . 1264<sup>b</sup> (Mack)  
 cf Lord of Hosts. . . . . 1919<sup>a</sup>
- Sabat  
 cf Saphat. . . . . 2690<sup>b</sup>
- Sabateus (Shabbethai). . . . . 2629<sup>b</sup>
- Sabathus (Zabad). . . . . 2629<sup>b</sup>
- Sabatus  
 cf Sabathus. . . . . 2629<sup>b</sup>
- Sabban  
 cf Sabannus. . . . . 2629<sup>b</sup>
- Sabbateus (Shabbethai). . . . . 2629<sup>b</sup>
- Sabbath. . . . . 2629<sup>b</sup> (Sampey)  
 cf Ethics of Jesus. . . . . 1026<sup>a</sup> (Stalker)  
 History of. . . . . 2631<sup>a</sup>  
 Jesus and the. . . . . 2631<sup>b</sup>  
 cf Lord's Day. . . . . 1920<sup>a</sup> (Easton)  
 cf Meals. . . . . 2015<sup>a</sup> (Eager)  
 cf Number. . . . . 2160<sup>a</sup> (Smith)  
 Origin, Biblical account. . . . . 2630<sup>a</sup>  
 Origin, critical views. . . . . 2630<sup>b</sup>  
 In OT and Maccabean times. . . . . 2631<sup>a</sup>  
 Paul's teaching regarding the. . . . . 2631<sup>b</sup>  
 cf Rest. . . . . 2561<sup>b</sup> (W. L. Walker)
- Seventh-day Adventist position. . . . . 2632<sup>a</sup> (Prescott)
- cf Ten Commandments, The. . . . . 2944<sup>b</sup> (Sampey)
- Sabbath-breaking  
 cf Crimes. . . . . 745<sup>b</sup> (Hirsch)  
 cf Punishments. . . . . 2504<sup>b</sup> (Hirsch)
- Sabbath, Court of the  
 cf Covered Way. . . . . 733<sup>a</sup> (Hirsch)
- Sabbath, Day before the 798<sup>b</sup> (Hirsch)
- Sabbath Day's Journey. . . . . 2634<sup>a</sup> (Porter)  
 cf Weights and Measures. . . . . 3079<sup>a</sup> (Porter)
- Sabbath, Morrow after the. . . . . 2083<sup>a</sup> (Hirsch)
- Sabbath, Second after the First. . . . . 2634<sup>b</sup> (Baur)
- Sabbatheus  
 cf Sabbateus. . . . . 2629<sup>b</sup>
- Sabbaths of Years. . . . . 2634<sup>b</sup>  
 cf Astronomy. . . . . 300<sup>b</sup> (Maunder)  
 cf Jubilee Year. . . . . 1756<sup>a</sup> (Baur)
- Sabbatical Year. . . . . 2634<sup>b</sup> (Baur)  
 cf Astronomy. . . . . 300<sup>b</sup> (Maunder)  
 Central idea. . . . . 2635<sup>b</sup>  
 cf Jubilee Year. . . . . 1756<sup>a</sup> (Baur)  
 Mosaic legislation. . . . . 2635<sup>a</sup>  
 Observance. . . . . 2635<sup>a</sup>  
 Primary intention. . . . . 2635<sup>a</sup>  
 cf Sabbath. . . . . 2629<sup>b</sup> (Sampey)
- Sabbeus (Shemaiah). . . . . 2636<sup>a</sup>
- Sabi (Shobai). . . . . 2636<sup>a</sup>  
 cf Sabie. . . . . 2636<sup>a</sup>
- Sabians  
 In Arabia. . . . . 219<sup>b</sup> (Weir)
- Sabias (Hashabiah). . . . . 2636<sup>a</sup>
- Sabie. . . . . 2636<sup>a</sup>
- Sabta, Sabtah. . . . . 2636<sup>a</sup> (Fulton)

- Sabteca, Sabtechah . . . . .2636<sup>a</sup> (Ewing)  
 Sacar . . . . .2636<sup>a</sup>  
 Sackbut  
   of Music . . . . .2094<sup>b</sup> (Millar)  
 Sackcloth  
   of Burial . . . . .529<sup>a</sup> (Eager)  
 Sacraments . . . . .2636<sup>a</sup> (Lambert)  
   of Baptism . . . . .385<sup>b</sup> (A. T. Robertson;  
     T. M. Lindsay; Dau)  
   Efficacy . . . . .2637<sup>b</sup>  
   Instituted by Christ . . . . .2637<sup>a</sup>  
   of Jesus Christ (Lord's  
     Supper) . . . . .1658<sup>b</sup> (Orr)  
   of Johannine Theology 1704<sup>b</sup> (Law)  
   of Lord's Supper . . . . .1924<sup>b</sup> (Dosker)  
   Nature and number . . . . .2636<sup>b</sup>  
   Term, the . . . . .2636<sup>b</sup>  
 Sacrifice, Human . . . . .2658<sup>a</sup> (McGlothlin)  
   Biblical instances . . . . .2658<sup>a</sup>  
   Heathen usage . . . . .2658<sup>a</sup>  
   of Jephthah . . . . .1587<sup>a</sup> (Schenk)  
   of Sacrifice (OT) . . . . .2638<sup>a</sup> (Reeve)  
   Use by Hebrews . . . . .2658<sup>a</sup>  
 Sacrifice (NT) . . . . .2651<sup>a</sup> (Williams)  
   Appeal of Christ's  
     death . . . . .2657<sup>a</sup>  
   Attitude of Jesus and  
     NT . . . . .2652<sup>a</sup>  
   Blood offerings vs.  
     ethical views . . . . .2651<sup>b</sup>  
   Cancellation of guilt  
     by sacrifice of Christ 2654<sup>a</sup>  
   Christ's sacrifice needs  
     completion . . . . .2657<sup>a</sup>  
   Christian life as sacri-  
     fice . . . . .2656<sup>b</sup>  
   How Christ's sacrifice  
     procures salvation . . . . .2654<sup>a</sup>  
   Human conditions of  
     application . . . . .2656<sup>a</sup>  
   Idea in NT . . . . .2652<sup>b</sup>  
   Jesus' acceptance of  
     the doctrine . . . . .2652<sup>b</sup>  
   Jesus' teaching . . . . .2652<sup>a</sup>  
   Jesus' teaching re-  
     garding method of  
     salvation . . . . .2654<sup>a</sup>  
   Justification by sacri-  
     fice of Christ . . . . .2654<sup>a</sup>  
   Lord's Supper as a  
     sacrifice . . . . .2657<sup>b</sup>  
   of Mediation, Mediator 2018<sup>a</sup> (Edwards)  
   Nature of Christian  
     sacrifice . . . . .2657<sup>a</sup>  
   Paul and the Epistle to  
     the Hebrews . . . . .2652<sup>a</sup>  
   Paul's teaching regard-  
     ing method of sal-  
     vation . . . . .2654<sup>b</sup>  
   Paul's use of terms . . . . .2654<sup>b</sup>  
   Rationale of Christ's  
     sacrifice . . . . .2656<sup>a</sup>  
 Sacrifice (NT)—*continued*  
   Reconciliation by the  
     sacrifice of Christ . . . . .2653<sup>b</sup>  
     of Reconciliation . . . . .2536<sup>a</sup> (M'Caig)  
   Redemption by the  
     sacrifice of Christ . . . . .2653<sup>a</sup>  
   Relation of Christ's  
     sacrifice to salvation 2653<sup>a</sup>  
   Remission by sacrifice  
     of Christ . . . . .2653<sup>b</sup>  
   Requirements for ap-  
     propriation . . . . .2656<sup>b</sup>  
   of Retribution . . . . .2570<sup>a</sup> (M'Caig)  
   of Romans, Epistle to  
     the . . . . .2614<sup>a</sup> (Dunelm)  
   of Salvation . . . . .2666<sup>a</sup> (Easton)  
   Sanctification by sacri-  
     fice of Christ . . . . .2654<sup>a</sup>  
   Summaries of the doc-  
     trine . . . . .2657<sup>b</sup>  
   Terms employed . . . . .2651<sup>b</sup>  
 Sacrifice (OT) . . . . .2638<sup>a</sup> (Reeve)  
   of Abel . . . . .5<sup>a</sup> (M. O. Evans)  
   of Altar . . . . .106<sup>b</sup> (Wiener; Caldecott)  
   of In ancient Greece . . . . .1302<sup>b</sup> (Fairbanks)  
   Classification of . . . . .2641<sup>a</sup>  
   of Hands, Imposition  
     of . . . . .1335<sup>a</sup> (Orr)  
   of Heifer, Red . . . . .1367<sup>b</sup> (Easton)  
   of Hospitality . . . . .1432<sup>a</sup> (Easton)  
   Idea and efficacy of . . . . .2649<sup>a</sup>  
     Food, adoration, de-  
       votion . . . . .2649<sup>a</sup>  
     Purification and con-  
       secration . . . . .2649<sup>b</sup>  
     Sacramental view . . . . .2649<sup>b</sup>  
     Symbol of prayer . . . . .2650<sup>a</sup>  
     Typology of sacri-  
       fice . . . . .2650<sup>b</sup>  
     Vicarious expiation . . . . .2650<sup>a</sup>  
   of Kidneys . . . . .1797<sup>b</sup> (Easton)  
   of Law in OT . . . . .1856<sup>b</sup> (Rule)  
 Mosaic sacrifices . . . . .2642<sup>b</sup>  
   Aaron and his sons . . . . .2643<sup>a</sup>  
   Burnt offering . . . . .2643<sup>a</sup>  
   Common altars . . . . .2642<sup>b</sup>  
   Covenant sacrifice . . . . .2642<sup>b</sup>  
   Drink offering . . . . .2645<sup>b</sup>  
   Guilt offering . . . . .2645<sup>a</sup>  
   Heave and wave  
     offerings . . . . .2645<sup>b</sup>  
   Meal offering . . . . .2643<sup>b</sup>  
   Peace offering . . . . .2644<sup>a</sup>  
   Sin offering . . . . .2644<sup>b</sup>  
 Origin and nature of . . . . .2639<sup>a</sup>  
   Theories of natural  
     origin . . . . .2639<sup>b</sup>  
   Theory of Divine  
     revelation . . . . .2639<sup>b</sup>  
   Theory of homage . . . . .2640<sup>a</sup>  
   Theory of peculiar  
     offerings . . . . .2640<sup>a</sup>

- Sacrifice (OT)—*continued*
- Origin and nature of—*continued*
    - Theory of religious instincts. . . . . 2640<sup>b</sup>
    - Theory of sacrificial meal. . . . . 2639<sup>b</sup>
  - Pre-Mosaic Age. . . . . 2641<sup>a</sup>
    - Egypt and Babylonia. . . . . 2641<sup>a</sup>
    - Patriarchal examples. . . . . 2642<sup>a</sup>
    - Primitive instances. . . . . 2641<sup>b</sup>
  - of Priests and Levites. . . . . 2452<sup>a</sup> (Wiener)
  - Prophets and sacrifice. . . . . 2647<sup>b</sup>
    - Amos and Hosea. . . . . 2647<sup>b</sup>
    - Ezekiel. . . . . 2648<sup>a</sup>
    - Jeremiah. . . . . 2648<sup>a</sup>
    - Micah and Isaiah. . . . . 2648<sup>a</sup>
  - Sacrifice in the history. . . . . 2646<sup>a</sup>
    - David and Solomon. . . . . 2646<sup>b</sup>
    - Early days. . . . . 2646<sup>a</sup>
    - Exilic and post-exilic ages. . . . . 2647<sup>a</sup>
    - Human sacrifices. . . . . 2647<sup>b</sup>
    - Northern kingdom. . . . . 2646<sup>b</sup>
    - Samuel and Saul. . . . . 2646<sup>a</sup>
    - Southern kingdom. . . . . 2647<sup>a</sup>
  - of Sacrifice, Human. . . . . 2658<sup>a</sup> (McGlothlin)
  - Sacrifice in the "Writings" . . . . . 2648<sup>b</sup>
  - of Shoulder. . . . . 2780<sup>b</sup> (Luring)
  - Terms and definitions. . . . . 2638<sup>b</sup>
  - of Thigh. . . . . 2972<sup>b</sup> (Easton)
  - of Totemism. . . . . 3000<sup>a</sup> (M. O. Evans)
  - of Trespass. . . . . 3010<sup>a</sup> (Dungan)
  - of Wine. . . . . 3088<sup>a</sup> (Easton)
  - Sacrilege. . . . . 2658<sup>b</sup>
  - Sadamias
    - of Salemas. . . . . 2663<sup>a</sup>
  - Sadas
    - of Astad. . . . . 295<sup>a</sup>
  - Saddeus
    - of Loddeus. . . . . 1909<sup>b</sup>
  - Saddle (noun). . . . . 2658<sup>b</sup>
  - Saddle (verb). . . . . 2658<sup>b</sup>
  - Sadducees. . . . . 2658<sup>b</sup> (J. E. H. Thomson); 458<sup>a</sup> (Dosker)
    - Acceptance of Pentateuch alone. . . . . 2660<sup>a</sup>
    - Attitude toward apostles. . . . . 2660<sup>a</sup>
    - Attitude toward Jesus. . . . . 2659<sup>b</sup>
    - Character of. . . . . 2660<sup>b</sup>
    - Disbelief in traditions. . . . . 2660<sup>a</sup>
    - Doctrines of. . . . . 2660<sup>a</sup>
    - Fall of the party. . . . . 2660<sup>a</sup>
    - Jesus and the. . . . . 2661<sup>a</sup>
    - of Jesus Christ. . . . . 1656<sup>b</sup> (Orr)
    - of Josephus Flavius. . . . . 1742<sup>a</sup> (Wenley)
    - Literature of. . . . . 2660<sup>b</sup>
    - of Maccabees, Books
      - of. . . . . 1949<sup>a</sup> (T. W. Davies)
  - Sadducees—*continued*
    - Meaning of name. . . . . 2659<sup>a</sup>
    - of Pharisees. . . . . 2361<sup>a</sup> (J. E. H. Thomson)
    - Relation to temple. . . . . 2660<sup>b</sup>
    - Relations with Hellenism. . . . . 2659<sup>b</sup>
    - Rise of the party. . . . . 2659<sup>b</sup>
    - Sources of knowledge
      - of. . . . . 2659<sup>a</sup>
    - Talmudic testimony regarding. . . . . 2660<sup>b</sup>
    - Testimony of Josephus regarding. . . . . 2659<sup>a</sup>
    - Treatment by Jewish rulers. . . . . 2659<sup>b</sup>
  - Sadduk. . . . . 2661<sup>a</sup>
    - of Zadok. . . . . 3129<sup>b</sup> (Whitelaw)
  - Sadoc. . . . . 2661<sup>a</sup>
    - of Zadok. . . . . 3129<sup>b</sup> (Whitelaw)
  - Safed
    - of Naphtali. . . . . 2119<sup>b</sup> (Ewing)
  - Saffron. . . . . 2661<sup>a</sup> (Masterman)
  - Sail, Sailor. . . . . 2661<sup>a</sup>
    - of Ships and Boats. . . . . 2774<sup>a</sup> (Nicol)
  - Saints. . . . . 2661<sup>a</sup> (Estes)
    - of Separate. . . . . 2721<sup>b</sup>
  - Sala, Salah. . . . . 2662<sup>a</sup>
    - of Shelah. . . . . 2758<sup>b</sup>
  - Salamiel. . . . . 2662<sup>a</sup>
    - of Shelumiel. . . . . 2759<sup>a</sup> (Wolf)
  - Salamis. . . . . 2662<sup>a</sup> (Tod)
    - Early history. . . . . 2662<sup>a</sup>
    - Later history. . . . . 2662<sup>b</sup>
    - Site. . . . . 2662<sup>a</sup>
    - Visit of Paul and Barnabas. . . . . 2662<sup>a</sup>
  - Salasadai. . . . . 2662<sup>b</sup>
  - Salathiel. . . . . 2662<sup>b</sup>
    - of Phaltiel. . . . . 2358<sup>b</sup>
    - of Shealtiel. . . . . 2752<sup>a</sup>
  - Sale. . . . . 2662<sup>b</sup>
  - Salcah, Salcah, Salchah. . . . . 2662<sup>b</sup> (Ewing)
  - Salem (person). . . . . 2663<sup>a</sup>
    - of Shallum. . . . . 2747<sup>a</sup> (Umbach)
  - Salem (place). . . . . 2663<sup>a</sup> (Pinches)
    - of Jerusalem, History. . . . . 1595<sup>b</sup> (Masterman)
    - of King's Vale. . . . . 1808<sup>a</sup> (Masterman)
  - Salemas (Sadamias). . . . . 2663<sup>a</sup>
    - of Shallum. . . . . 2747<sup>a</sup> (Umbach)
  - Salim. . . . . 2663<sup>a</sup> (Ewing)
    - of Aenon. . . . . 65<sup>b</sup> (Ewing)
  - Salimoth. . . . . 2663<sup>b</sup>
    - of Shelomith. . . . . 2759<sup>a</sup> (Wolf)
  - Sallai. . . . . 2663<sup>b</sup>
  - Sallu
    - of Sallai. . . . . 2663<sup>b</sup>
  - Sallumus. . . . . 2663<sup>b</sup>
    - of Salum. . . . . 2665<sup>a</sup>
    - of Shallum. . . . . 2747<sup>a</sup> (Umbach)
  - Salma
    - of Salmon. . . . . 2663<sup>b</sup> (S. F. Hunter)

Salmai . . . . . 2663<sup>b</sup>  
   cf Shalmal . . . . . 2747<sup>b</sup>  
   cf Subai . . . . . 2868<sup>a</sup>  
 Salmanasar . . . . . 2663<sup>b</sup>  
   cf Shalmaneser . . . . . 2747<sup>b</sup> (Nicol)  
 Salmon, Salma . . . . . 2663<sup>b</sup> (S. F. Hunter)  
   cf Zalmon . . . . . 3131<sup>b</sup> (Ewing)  
 Salmons . . . . . 2663<sup>b</sup>  
   cf Phoenix . . . . . 2391<sup>a</sup> (Calder)  
 Saloas . . . . . 2664<sup>a</sup>  
   cf Elasa . . . . . 923<sup>a</sup>  
   cf Talsas . . . . . 2907<sup>b</sup>  
 Salom . . . . . 2664<sup>a</sup>  
   cf Salu . . . . . 2664<sup>b</sup>  
   cf Shallum . . . . . 2747<sup>a</sup> (Umbach)  
 Salome . . . . . 2664<sup>a</sup> (Orr)  
   cf Zebedee . . . . . 3134<sup>a</sup>  
 Salt . . . . . 2664<sup>a</sup> (Patch)  
   cf Covenant of Salt . . . . . 729<sup>b</sup> (Pollard)  
   cf Dead Sea . . . . . 801<sup>a</sup> (Wright)  
   cf Food . . . . . 1121<sup>b</sup> (Eager)  
 Salt, City of . . . . . 2664<sup>b</sup>  
   cf Moladah . . . . . 2073<sup>b</sup> (Masterman)  
 Salt, Covenant of . . . . . 729<sup>b</sup> (Pollard)  
 Salt, Pillar of  
   cf Lot . . . . . 1929<sup>b</sup> (Boyd)  
   cf Salt . . . . . 2664<sup>a</sup> (Patch)  
   cf Siddim, Vale of . . . . . 2784<sup>a</sup> (Wright)  
   cf Slime . . . . . 2817<sup>b</sup> (Day)  
 Salt Sea  
   cf Dead Sea . . . . . 801<sup>a</sup> (Wright)  
 Salt, Valley of . . . . . 2664<sup>b</sup> (Masterman)  
   cf Sela . . . . . 2713<sup>b</sup> (Ewing)  
 Salt-wort . . . . . 2664<sup>b</sup> (Masterman)  
   cf Juniper . . . . . 1781<sup>a</sup> (Masterman)  
 Salu . . . . . 2664<sup>b</sup>  
   cf Salom . . . . . 2664<sup>a</sup>  
 Salum . . . . . 2665<sup>a</sup>  
   cf Sallumus . . . . . 2663<sup>b</sup>  
   cf Shallum . . . . . 2747<sup>a</sup> (Umbach)  
 Salutation . . . . . 2665<sup>a</sup> (Pollard)  
   cf Knee . . . . . 1815<sup>a</sup> (Easton)  
 Salvation . . . . . 2665<sup>a</sup> (Easton)  
   cf Atonement . . . . . 321<sup>a</sup> (Carver)  
   cf Heredity . . . . . 1376<sup>a</sup> (Easton)  
   cf Hope . . . . . 1419<sup>b</sup> (Easton)  
   Intermediate literature 2666<sup>b</sup>  
     General references . . . . . 2666<sup>b</sup>  
     Law, views of the . . . . . 2667<sup>a</sup>  
   cf Johannine Theology 1695<sup>b</sup> (Law)  
   cf Justification . . . . . 1782<sup>b</sup> (Faulkner)  
   cf Mark, Gospel of . . . . . 1994<sup>b</sup> (Farmer)  
   cf Mediation, Medi-  
     ator . . . . . 2018<sup>a</sup> (Edwards)  
   In OT . . . . . 2665<sup>a</sup>  
     General teaching . . . . . 2665<sup>a</sup>  
     Moral law . . . . . 2666<sup>a</sup>  
     Nation and indi-  
       vidual . . . . . 2665<sup>b</sup>  
     Ritual law . . . . . 2666<sup>b</sup>  
     Sacrifices . . . . . 2666<sup>a</sup>  
   cf Paul, Theology of . . . . . 2290<sup>b</sup> (Easton)

Salvation—*continued*

  cf Person of Christ . . . . . 2338<sup>a</sup> (Warfield)  
   Rest of NT . . . . . 2670<sup>a</sup>  
     Hebrews, Ep. to . . . . . 2670<sup>b</sup>  
     St. John . . . . . 2760<sup>a</sup>  
     Summaries . . . . . 2670<sup>b</sup>  
   cf Resurrection . . . . . 2562<sup>a</sup> (Easton)  
   cf Sanctification . . . . . 2681<sup>b</sup> (Rall)  
   cf Saviour . . . . . 2700<sup>a</sup> (Easton)  
   cf Spiritual Gifts . . . . . 2843<sup>a</sup> (Lambert)  
   Teaching of Jesus . . . . . 2667<sup>a</sup>  
     Individualism . . . . . 2667<sup>b</sup>  
     John the Baptist . . . . . 2667<sup>a</sup>  
     Kingdom of God . . . . . 2667<sup>b</sup>  
     Moral progress . . . . . 2667<sup>b</sup>  
     Person of Christ . . . . . 2668<sup>a</sup>  
     Present and future . . . . . 2667<sup>b</sup>  
   Teaching of Paul . . . . . 2668<sup>b</sup>  
     Atonement . . . . . 2669<sup>b</sup>  
     Forgiveness . . . . . 2669<sup>a</sup>  
     General views . . . . . 2668<sup>b</sup>  
     Holy Spirit . . . . . 2669<sup>a</sup>  
     Moral progress . . . . . 2668<sup>b</sup>  
     Mystical union . . . . . 2669<sup>a</sup>  
     Terms used . . . . . 2665<sup>a</sup>  
     cf Zoroastrianism . . . . . 3157<sup>a</sup> (Easton)  
 Samael  
   cf Salamiel . . . . . 2662<sup>a</sup>  
 Samaias . . . . . 2671<sup>a</sup> (Angus)  
   cf Shemaiah . . . . . 2759<sup>b</sup> (Wolf)  
 Samaria, City of . . . . . 2671<sup>a</sup> (Ewing)  
   Captured by Sargon . . . . . 571<sup>a</sup> (Nicol)  
   Christian events . . . . . 2672<sup>b</sup>  
   Depopulation and re-  
     population of . . . . . 571<sup>b</sup> (Nicol)  
   Excavations . . . . . 2671<sup>b</sup>  
   Herod's buildings . . . . . 2672<sup>a</sup>  
   History . . . . . 2671<sup>b</sup>  
   Location . . . . . 2671<sup>b</sup>  
   cf Mingled People . . . . . 2056<sup>b</sup> (Easton)  
   cf Omri . . . . . 2192<sup>b</sup> (Mosiman)  
   Origin and name . . . . . 2671<sup>a</sup>  
   cf Palestine, Recent Ex-  
     ploration . . . . . 2230<sup>b</sup> (Cobern)  
   Sieges . . . . . 2671<sup>b</sup>  
 Samaria, Country of . . . . . 2672<sup>b</sup> (Ewing)  
   Boundaries . . . . . 2672<sup>b</sup>  
   Invasion and fall . . . . . 2673<sup>b</sup>  
   Later history . . . . . 2673<sup>a</sup>  
   cf Samaritans . . . . . 2673<sup>b</sup> (Ewing)  
   Scenery . . . . . 2673<sup>b</sup>  
 Samaria, Woman of  
   cf Jesus Christ . . . . . 1638<sup>a</sup> (Orr)  
 Samaritan Pentateuch,  
   The . . . . . 2312<sup>b</sup> (J. E. H. Thomson)  
 Samaritans . . . . . 2673<sup>b</sup> (Ewing)  
   cf Gerizim, Mount . . . . . 1218<sup>a</sup> (Ewing)  
   Later history and  
     present status . . . . . 2674<sup>a</sup>  
   Origin of the race . . . . . 2673<sup>b</sup>  
   cf Pentateuch, The Sa-  
     maritan . . . . . 2312<sup>b</sup> (J. E. H. Thomson)

Samaritans—*continued*

- Relations with Jews.. 2674<sup>a</sup>  
 of Samaria, Country of 2672<sup>b</sup> (Ewing)  
 Samatus..... 2674<sup>a</sup>  
 Samech..... 2674<sup>a</sup>  
 of Alphabet..... 103<sup>b</sup> (Richardson)  
 Sameius  
 cf Sameus..... 2674<sup>a</sup>  
 Samellius..... 2674<sup>a</sup>  
 of Shimshai..... 2771<sup>a</sup> (Wolf)  
 Sameus..... 2674<sup>a</sup>  
 cf Shemaiah..... 2759<sup>b</sup> (Wolf)  
 Samgar-nebo..... 2674<sup>b</sup> (Wolf)  
 cf Rab-mag..... 2522<sup>a</sup> (Clippinger)  
 cf Rab-saris..... 2522<sup>b</sup> (Clippinger)  
 Sami  
 cf Sabi..... 2636<sup>a</sup>  
 Samis  
 cf Someis..... 2826<sup>a</sup>  
 Samlah..... 2674<sup>b</sup>  
 Sammus..... 2674<sup>b</sup>  
 cf Shema..... 2759<sup>b</sup> (Wolf)  
 Samos..... 2674<sup>b</sup> (Kinsella)  
 cf Chios..... 611<sup>b</sup> (Harry)  
 cf Cos..... 723<sup>a</sup> (Harry)  
 cf Ephesus..... 961<sup>a</sup> (Banks)  
 cf Miletus..... 2051<sup>b</sup> (Banks)  
 cf Samothrace..... 2675<sup>a</sup> (Kinsella)  
 Samothrace..... 2675<sup>a</sup> (Kinsella)  
 cf Neapolis..... 2126<sup>a</sup> (Tod)  
 cf Philippi..... 2369<sup>a</sup> (Tod)  
 cf Samos..... 2674<sup>b</sup> (Kinsella)  
 Sampsames..... 2675<sup>a</sup>  
 Samson..... 2675<sup>a</sup> (Robinson); 781<sup>b</sup>  
 (Ewing); 820<sup>b</sup> (Beecher)  
 cf Abdon..... 4<sup>a</sup> (Beecher)  
 Adventures in Philistia 2676<sup>a</sup>  
 Historicity of the  
 stories..... 2676<sup>b</sup>  
 cf Manoah..... 1983<sup>b</sup> (Schenk)  
 Marriage..... 2675<sup>b</sup>  
 Name and character.. 2675<sup>a</sup>  
 cf Palestine..... 2214<sup>a</sup> (Conder)  
 Religious value of the  
 stories..... 2676<sup>b</sup>  
 Story of his life..... 2675<sup>b</sup>  
 Samson, History of  
 cf Judges, Book of... 1772<sup>a</sup> (Geden)  
 Samuel..... 2677<sup>a</sup> (Geden)  
 Anointing of David... 792<sup>a</sup> (Weir)  
 Character and in-  
 fluence..... 2678<sup>a</sup>  
 cf King..... 1800<sup>b</sup> (Press)  
 cf Libraries..... 1884<sup>b</sup> (Richardson)  
 Meaning of name... 2677<sup>a</sup>  
 cf Names, Proper... 2116<sup>a</sup> (Davis)  
 Public service..... 2677<sup>b</sup>  
 Rejection of Saul... 2678<sup>a</sup>  
 Relations with David.. 2678<sup>a</sup>  
 cf Samuel, Books of... 2678<sup>b</sup> (Geden)  
 cf Saul..... 2698<sup>b</sup> (Weir)  
 cf Shemuel..... 2761<sup>a</sup>

Samuel—*continued*

- cf Shiloh..... 2769<sup>a</sup> (Ewing)  
 Sources..... 2677<sup>a</sup>  
 Two narratives of  
 Saul's elevation... 2677<sup>b</sup>  
 Youth at Shiloh.... 2677<sup>a</sup>  
 Samuel, Books of..... 2678<sup>b</sup> (Geden)  
 Analysis, life of Sam-  
 uel..... 2679<sup>a</sup>  
 Analysis, reign of  
 David..... 2679<sup>b</sup>  
 Contents..... 2679<sup>a</sup>  
 Date of sources.... 2680<sup>b</sup>  
 Ethical and religious  
 teaching..... 2680<sup>b</sup>  
 Greek versions..... 2680<sup>b</sup>  
 cf Jesse..... 1623<sup>a</sup> (Roberts)  
 cf Palestine..... 2214<sup>b</sup> (Conder)  
 Period of history... 2679<sup>a</sup>  
 Position in canon... 2678<sup>b</sup>  
 cf Samuel..... 2677<sup>a</sup> (Geden)  
 cf Saul..... 2698<sup>a</sup> (Weir)  
 Sources of history... 2680<sup>a</sup>  
 Two main narratives. 2680<sup>a</sup>  
 Sanaas..... 2681<sup>a</sup>  
 cf Senaah..... 2719<sup>b</sup> (Ewing)  
 Sanabassar, Sanabas-  
 sarus..... 2681<sup>a</sup> (Angus)  
 cf Shenazzar..... 2761<sup>a</sup>  
 cf Sheshbazzar..... 2766<sup>a</sup> (R. D. Wilson)  
 cf Zerubbabel..... 3147<sup>b</sup> (R. D. Wilson)  
 Sanasib..... 2681<sup>a</sup>  
 Sanballat..... 2681<sup>a</sup> (R. D. Wilson)  
 Sanctification..... 2681<sup>b</sup> (Rall)  
 Change from formal to  
 ethical idea..... 2683<sup>a</sup>  
 Criticisms and answers 2686<sup>a</sup>  
 Doctrine stated..... 2685<sup>b</sup>  
 Element in Christian  
 life..... 2684<sup>a</sup>  
 Ethical sense..... 2683<sup>a</sup>  
 Etymology..... 2681<sup>b</sup>  
 Fellowship with God. 2684<sup>a</sup>  
 Formal sense in NT... 2682<sup>b</sup>  
 Formal sense in OT... 2682<sup>a</sup>  
 As God's gift..... 2683<sup>b</sup>  
 cf Holiness..... 1403<sup>b</sup> (Lambert)  
 cf Holy Spirit..... 1406<sup>a</sup> (Mullins)  
 Instantaneous and en-  
 tire?..... 2684<sup>b</sup>  
 cf Justice..... 1781<sup>b</sup> (Rall)  
 Man's task..... 2685<sup>a</sup>  
 cf Pauline Theology.. 2290<sup>b</sup> (Easton)  
 Paul's teaching on... 2683<sup>a</sup>  
 Relation to God per-  
 sonal..... 2683<sup>b</sup>  
 cf Sacrifice, NT..... 2654<sup>a</sup> (Williams)  
 cf Salvation..... 2665<sup>a</sup> (Easton)  
 cf Self-righteousness.. 2715<sup>b</sup> (Carver)  
 cf Sin..... 2801<sup>b</sup> (McConnell)  
 Time and method.... 2683<sup>b</sup>

- Sanctification, Wesleyan  
 Doctrine..... 2685<sup>b</sup> (Steele)  
 Hymnology..... 2686<sup>a</sup>  
 Wesley's personal testimony..... 2686<sup>b</sup>
- Sanctity, Legislation of  
 cf Astronomy..... 300<sup>b</sup> (Maunder)
- Sanctuary..... 2686<sup>b</sup> (Wiener)  
 cf Altar..... 106<sup>b</sup> (Wiener; Caldecott)  
 Critical views..... 2686<sup>b</sup>  
 Difficulties of critical views..... 2687<sup>a</sup>  
 Explanation attempted..... 2688<sup>a</sup>  
 cf High Place..... 1390<sup>a</sup> (Easton)  
 cf Pentateuch..... 2298<sup>a</sup> (Wiener)  
 cf Priests and Levites. 2447<sup>a</sup>; 2450<sup>a</sup> (Wiener)  
 cf Seveneh..... 2744<sup>a</sup>  
 cf Tabernacle..... 2887<sup>b</sup> (Caldecott; Orr)  
 cf Temple..... 2930<sup>a</sup> (Caldecott; Orr)  
 cf Worship..... 3111<sup>a</sup> (Crannell)
- Sand..... 2688<sup>b</sup> (Day)  
 cf Rock..... 2596<sup>a</sup> (Day)  
 cf Shore..... 2779<sup>b</sup> (Day)
- Sandal  
 cf Dress..... 875<sup>b</sup> (Eager)  
 cf Shoe..... 2779<sup>a</sup> (Easton)
- Sand Flies..... 2688<sup>b</sup>  
 cf Flea..... 1118<sup>b</sup> (Day)  
 cf Gnat..... 1240<sup>a</sup> (Day)  
 cf Insects..... 1473<sup>a</sup> (Day)  
 cf Lice..... 1886<sup>b</sup> (Day)
- Sand, Glowing  
 cf Mirage..... 2066<sup>a</sup> (Joy)
- Sand-lizard..... 2688<sup>b</sup>  
 cf Lizard..... 1906<sup>a</sup> (Day)  
 cf Snail..... 2819<sup>a</sup> (Day)
- Sanhedrin..... 2688<sup>b</sup> (Levertoff)  
 Constitution..... 2689<sup>b</sup>  
 cf Jesus Christ (Powers of Sanhedrin)..... 1660<sup>a</sup> (Orr)  
 cf Jesus Christ's Arrest. 1671<sup>b</sup> (Maclaren)  
 Jurisdiction..... 2689<sup>b</sup>  
 cf Law, Judicial..... 1858<sup>a</sup> (Hirsch)  
 Literature..... 2690<sup>a</sup>  
 Name..... 2688<sup>b</sup>  
 Origin and history..... 2689<sup>a</sup>  
 Place and time of meeting..... 2690<sup>a</sup>  
 Procedure..... 2690<sup>a</sup>  
 cf Senate..... 2719<sup>b</sup> (Heidel)  
 cf Talmud..... 2904<sup>b</sup> (Strack)
- Sansannah..... 2690<sup>a</sup>
- Saph (Sippai)..... 2690<sup>b</sup>
- Saphat..... 2690<sup>b</sup>  
 cf Shephatiah..... 2762<sup>a</sup> (Orr)
- Saphatias..... 2690<sup>b</sup>  
 cf Shephatiah..... 2762<sup>a</sup> (Orr)
- Sapheth  
 cf Saphuthi..... 2690<sup>b</sup>
- Saphir  
 cf Shaphir..... 2750<sup>a</sup> (Masterman)
- Saphuthi..... 2690<sup>b</sup>  
 cf Shephatiah..... 2762<sup>a</sup> (Orr)
- Sapphira..... 2690<sup>b</sup>  
 cf Ananias..... 129<sup>a</sup> (Edwards)
- Sapphire  
 cf Stones, Precious... 2856<sup>a</sup> (Fletcher)
- Saqqareh  
 cf Memphis..... 2030<sup>b</sup> (Petrie)
- Sarabias..... 2690<sup>b</sup>  
 cf Asebebias..... 266<sup>b</sup>  
 cf Sherebiah..... 2764<sup>b</sup> (Wolf)
- Sarah (Apoc)..... 2691<sup>b</sup> (Boyd)  
 cf Tobit, Book of..... 2990<sup>b</sup> (T. W. Davies)
- Sarah, Sarai..... 2690<sup>b</sup> (Boyd)  
 cf Abraham..... 18<sup>a</sup> (Boyd)  
 Birth of Isaac..... 2691<sup>a</sup>  
 Burial at Hebron..... 2691<sup>b</sup>  
 Character of..... 2691<sup>b</sup>  
 Forms of the name... 2690<sup>b</sup>  
 Mythical view..... 2691<sup>b</sup>  
 Relation to Abraham. 2691<sup>a</sup>
- Saraia..... 2691<sup>b</sup>  
 cf Azariaia..... 342<sup>a</sup>  
 cf Seraiah..... 2732<sup>a</sup> (Wolf)
- Saramel  
 cf Asaramel..... 263<sup>a</sup> (Wolf)
- Saraph..... 2692<sup>a</sup>
- Sarchedonus..... 2692<sup>a</sup>  
 cf Esar-haddon..... 971<sup>a</sup> (Clay)
- Sardeus  
 cf Zardeus..... 3132<sup>b</sup>
- Sardin(e), Sardius  
 cf Stones, Precious... 2856<sup>a</sup> (Fletcher)
- Sardis..... 2692<sup>a</sup> (Banks)  
 Biblical references... 2692<sup>a</sup>  
 Excavations at..... 2692<sup>a</sup>  
 History..... 2692<sup>a</sup>
- Sardite  
 cf Sered..... 2732<sup>b</sup>
- Sardius  
 cf Stones, Precious... 2856<sup>a</sup> (Fletcher)
- Sardonix  
 cf Stones, Precious... 2856<sup>a</sup> (Fletcher)
- Sarepta..... 2692<sup>b</sup>  
 cf Zarephath..... 3132<sup>b</sup> (Ewing)
- Sargon..... 2693<sup>a</sup> (Clay)  
 Capture of Samaria by 57<sup>a</sup> (Nicol)
- Sarid..... 2692<sup>b</sup>
- Saron..... 2693<sup>a</sup>  
 cf Sharon..... 2750<sup>b</sup> (Ewing)
- Sarothie..... 2693<sup>b</sup>
- Sarsechim..... 2693<sup>b</sup>
- Saruch..... 2693<sup>b</sup>  
 cf Serug..... 2738<sup>b</sup>
- Satan..... 2693<sup>b</sup> (Sweet)  
 Character..... 2693<sup>b</sup>  
 Divine unity..... 2696<sup>a</sup>  
 Foreign influence... 2696<sup>a</sup>  
 History of..... 2694<sup>b</sup>  
 Idea in OT..... 2695<sup>b</sup>  
 cf Job, Book of..... 1680<sup>b</sup>; 1681<sup>b</sup> (Genung)  
 cf Joshua (son of Jehozadak)..... 1748<sup>a</sup> (Roberts)



Satan—*continued*

- Limitations of . . . . . 2696<sup>a</sup>
- Mythological origin? . . . . . 2696<sup>a</sup>
- Names of . . . . . 2693<sup>b</sup>
- No systematic teaching . . . . . 2695<sup>a</sup>
- cf Persian Religion
  - (Ancient) . . . . . 2331<sup>b</sup> (Tisdall)
- Personality of . . . . . 2695<sup>a</sup>
- cf Principality . . . . . 2454<sup>b</sup> (Heidel)
- Relation to God . . . . . 2695<sup>b</sup>
- Scriptural statements . . . . . 2693<sup>b</sup>
- cf Temptation of
  - Christ . . . . . 2943<sup>a</sup> (Anderson)
- Works of . . . . . 2694<sup>a</sup>
- cf Zoroastrianism . . . . . 3157<sup>a</sup> (Easton)
- Satan, Depths of . . . . . 2696<sup>b</sup> (Forrester)
- Satan, Synagogue of . . . . . 2696<sup>b</sup> (Williams)
- Satchel
  - cf Bag . . . . . 377<sup>a</sup> (Eager)
- Sathrabuzanes . . . . . 2696<sup>b</sup>
- cf Shethar-bozenai . . . . . 2766<sup>b</sup> (Wolf)
- Satisfaction . . . . . 2697<sup>a</sup> (Downer)
- Satrap . . . . . 2697<sup>a</sup>
- Saturn or Moloch Worship . . . . . 298<sup>a</sup>
- Satyr . . . . . 2697<sup>a</sup> (Day)
  - cf Goat . . . . . 1248<sup>b</sup> (Day)
  - cf Jackal . . . . . 1548<sup>a</sup> (Day)
  - cf Zoology . . . . . 3155<sup>a</sup> (Day)
- Saul . . . . . 2697<sup>b</sup> (Weir); 255<sup>b</sup>
  - (Nicol)
  - Attitude of Chronicles toward . . . . . 2699<sup>b</sup>
  - Character . . . . . 2699<sup>b</sup>
  - David in the service
    - of . . . . . 791<sup>b</sup> (Weir)
    - cf David . . . . . 790<sup>b</sup> (Weir)
  - Duplicate accounts . . . . . 2698<sup>b</sup>
  - Genealogy . . . . . 2697<sup>b</sup>
  - cf Gibeah . . . . . 1225<sup>a</sup> (Ewing)
  - Home . . . . . 2697<sup>b</sup>
  - cf Ish-bosheth . . . . . 1508<sup>b</sup> (Breslich)
  - cf Jabesh-gilead . . . . . 1546<sup>b</sup> (Ewing)
  - cf Jonathan . . . . . 1730<sup>b</sup> (Weir)
  - cf Judah, Kingdom of . . . . . 1759<sup>a</sup> (Weir)
  - Last battle and death . . . . . 2699<sup>a</sup>
  - cf Mad, Madness . . . . . 1961<sup>a</sup> (Macalister)
  - Meaning of name . . . . . 2697<sup>b</sup>
  - cf Palestine . . . . . 2215<sup>a</sup> (Conder)
  - Posterity of . . . . . 2699<sup>b</sup>
  - Reign and fall . . . . . 2698<sup>a</sup>
  - Relations with David . . . . . 2698<sup>b</sup>
  - Relations with Samuel . . . . . 2698<sup>b</sup>
  - Rescue of Jabesh-gilead . . . . . 2698<sup>b</sup>
  - cf Samuel . . . . . 2677<sup>a</sup> (Geden)
  - cf Samuel, Books of . . . . . 2678<sup>b</sup> (Geden)
  - Sources and narrative . . . . . 2698<sup>a</sup>
  - Struggles against Philistines . . . . . 2698<sup>a</sup>

Saul—*continued*

- Virtues of . . . . . 2700<sup>a</sup>
- Weaknesses of . . . . . 2699<sup>b</sup>
- Saul of Tarsus
  - cf Paul, the Apostle . . . . . 2264<sup>b</sup> (A. T. Robertson)
- Savaran
  - cf Avaran . . . . . 340<sup>a</sup>
- Save . . . . . 2700<sup>a</sup>
- Savias . . . . . 2700<sup>a</sup>
  - cf Uzzi . . . . . 3043<sup>a</sup> (Roberts)
- Saviour . . . . . 2700<sup>a</sup> (Easton)
  - cf Salvation . . . . . 2665<sup>a</sup> (Easton)
- Savor . . . . . 2700<sup>b</sup> (Edwards)
  - cf Odor . . . . . 2178<sup>b</sup>
  - cf Triumph . . . . . 3022<sup>b</sup> (A. W. Evans)
- Saw
  - cf Tools . . . . . 2998<sup>b</sup> (Easton)
- Sawing Asunder . . . . . 316<sup>b</sup> (S. F. Hunter)
  - cf Punishments . . . . . 2504<sup>b</sup> (Hirsch)
- Sayest . . . . . 2701<sup>a</sup>
- Sayings, Dark . . . . . 789<sup>a</sup> (Margolis)
- Sayings, Faithful . . . . . 1091<sup>a</sup> (Rutherford)
- Sayings of Jesus
  - cf Logia . . . . . 1910<sup>a</sup> (Smith)
- Sayings, Unwritten
  - cf Agrapha . . . . . 72<sup>a</sup> (Smith)
- Scab, Scabbed . . . . . 2701<sup>a</sup> (Macalister)
- Scabbard, Sheath
  - cf Armor, Arms . . . . . 251<sup>a</sup> (Nicol)
  - cf War . . . . . 3069<sup>b</sup> (Nicol)
- Scaffold . . . . . 2701<sup>a</sup>
- Scale
  - cf Balance . . . . . 379<sup>b</sup> (Eager)
  - cf Siege . . . . . 2786<sup>a</sup> (Nicol)
  - cf Weights and Measures . . . . . 3079<sup>a</sup> (Porter)
- Scales . . . . . 2701<sup>a</sup> (Luering)
  - cf Leviathan . . . . . 1868<sup>b</sup> (Day)
- Scall . . . . . 2701<sup>b</sup>
- Scape-goat
  - cf Azazel . . . . . 343<sup>a</sup> (Möller)
- Scarlet
  - cf Colors . . . . . 674<sup>b</sup> (Patch)
  - cf Dyeing . . . . . 883<sup>b</sup> (Patch)
- Scarlet (Worm) . . . . . 2701<sup>b</sup>
  - cf Colors . . . . . 674<sup>b</sup> (Patch)
  - cf Dyeing . . . . . 883<sup>b</sup> (Patch)
  - cf Worm . . . . . 3109<sup>a</sup> (Day)
- Scattered Abroad
  - cf Dispersion . . . . . 855<sup>a</sup> (Nicol)
- Scent . . . . . 2701<sup>b</sup> (Easton)
- Sceptre, Scepter . . . . . 2701<sup>b</sup> (N. Isaacs)
  - cf Staff . . . . . 2847<sup>b</sup>
  - cf Staves . . . . . 2850<sup>a</sup> (Caldecott)
- Sceva . . . . . 2702<sup>a</sup> (S. F. Hunter)
- Schism . . . . . 2702<sup>a</sup>
- Scholasticism . . . . . 1018<sup>b</sup> (Alexander)
- School
  - cf Tyrannus . . . . . 3030<sup>a</sup> (S. F. Hunter)
- Schoolmaster . . . . . 2702<sup>b</sup> (Easton)
  - cf Pauline Theology . . . . . 2292<sup>a</sup> (Easton)
  - cf Tutor . . . . . 3028<sup>a</sup>

- Schools of the Prophets  
 cf Education. . . . . 900<sup>b</sup> (Meyer)  
 cf Prophets. . . . . 2459<sup>b</sup> (Orelli)
- Science . . . . . 2702<sup>b</sup> (Rutherford)  
 cf Gnosticism. . . . . 1240<sup>a</sup> (Rutherford)
- Scimitar. . . . . 2703<sup>a</sup>
- Scoff, Scoffer. . . . . 2703<sup>a</sup>
- Scorn. . . . . 2703<sup>a</sup> (McPheeters)
- Scorpion. . . . . 2703<sup>b</sup> (Day)  
 cf Insects. . . . . 1473<sup>a</sup> (Day)
- Scorpions, Chastising with  
 cf Punishments. . . . . 2506<sup>a</sup> (Hirsch)  
 cf Scorpion. . . . . 2703<sup>b</sup> (Day)
- Scourge, Scourging. . . . . 2704<sup>a</sup> (Dosker)
- Scrabble. . . . . 2704<sup>a</sup>
- Screech Owl  
 cf Night-monster. . . . . 2143<sup>b</sup> (Sweet)
- Scribes. . . . . 2704<sup>b</sup> (Hirsch)  
 Formalism result of  
 scribal work. . . . . 2705<sup>b</sup>  
 Generally Pharisees. . . . . 2705<sup>a</sup>  
 Greatness of the law. . . . . 2705<sup>b</sup>  
 Honor accorded to. . . . . 2704<sup>b</sup>  
 cf Lawyer. . . . . 1859<sup>a</sup> (Hirsch)  
 Outgrowth of priestly  
 service. . . . . 2704<sup>b</sup>  
 Proverbs regarding. . . . . 2705<sup>a</sup>  
 Remuneration. . . . . 2705<sup>a</sup>  
 Writers and teachers of  
 the law. . . . . 2704<sup>b</sup>
- Scrip. . . . . 2705<sup>b</sup>  
 cf Bag. . . . . 377<sup>a</sup> (Eager)
- Scripture. . . . . 2706<sup>a</sup> (Orr)  
 cf Bible. . . . . 459<sup>b</sup> (Orr)
- Scriptures, Search the  
 cf Search the Scrip-  
 tures. . . . . 2710<sup>a</sup> (Harry)
- Scroll  
 cf Roll. . . . . 2597<sup>a</sup> (Richardson)
- Sculpture and Inscrip-  
 tions  
 At Carchemish. . . . . 577<sup>b</sup> (Pinches)
- Scum. . . . . 2706<sup>a</sup>  
 cf Rust. . . . . 2627<sup>b</sup> (Patch)
- Scurvy. . . . . 2706<sup>a</sup> (Macalister)
- Scythians. . . . . 2706<sup>a</sup> (Porter)  
 cf Jeremiah. . . . . 1589<sup>b</sup> (Orelli)  
 cf Parthians. . . . . 2251<sup>b</sup> (Porter)  
 cf Zephaniah, Book of 3145<sup>a</sup> (Eiselen)
- Scythopolis. . . . . 2706<sup>b</sup>  
 cf Beth-shean. . . . . 452<sup>b</sup> (Ewing)
- Sea. . . . . 2706<sup>b</sup> (Day)  
 cf Sea of Jazer. . . . . 2707<sup>b</sup>
- Sea, Adriatic  
 cf Adria. . . . . 62<sup>a</sup> (Allen)
- Sea of Arabah  
 cf Dead Sea. . . . . 801<sup>a</sup> (Wright)
- Sea, Brazen  
 cf Sea, The Molten. . . . . 2708<sup>a</sup> (Caldecott)
- Sea of Chinnereth  
 cf Galilee, Sea of. . . . . 1165<sup>a</sup> (Ewing)
- Sea, Dead; Eastern  
 cf Dead Sea. . . . . 801<sup>a</sup> (Wright)
- Sea, Former  
 cf Dead Sea. . . . . 801<sup>a</sup> (Wright)  
 cf Former. . . . . 1136<sup>a</sup> (W. L. Walker)
- Sea of Galilee. . . . . 1165<sup>a</sup> (Ewing)  
 cf Ships and Boats. . . . . 2776<sup>a</sup> (Nicol)
- Sea of Glass. . . . . 1234<sup>b</sup> (Orr)
- Sea, The Great. . . . . 2707<sup>b</sup> (Ewing)  
 cf Acco. . . . . 28<sup>a</sup> (Porter)  
 Israel and the sea. . . . . 2707<sup>b</sup>  
 cf Joppa. . . . . 1731<sup>b</sup> (Ewing)  
 cf Mediterranean Sea. . . . . 2026<sup>b</sup> (Heidel)  
 Names of. . . . . 2707<sup>b</sup>  
 In the NT. . . . . 2708<sup>a</sup>  
 cf Paul, the Apostle. . . . . 2264<sup>b</sup> (A. T. Robertson)
- Sea, Hinder; Utmost;  
 Uttermost; Western  
 cf Mediterranean Sea. . . . . 2026<sup>b</sup> (Heidel)
- Sea of Jazer. . . . . 2707<sup>b</sup>  
 cf Jazer. . . . . 1572<sup>a</sup> (Ewing)  
 cf Sea. . . . . 2707<sup>a</sup> (Day)
- Sea of Joppa  
 cf Mediterranean Sea. . . . . 2026<sup>b</sup> (Heidel)
- Sea of Lot  
 cf Dead Sea. . . . . 801<sup>a</sup> (Wright)  
 cf Lake. . . . . 1822<sup>a</sup> (Day)
- Sea, Mediterranean. . . . . 2026<sup>b</sup> (Heidel)
- Sea-mew. . . . . 2707<sup>a</sup> (Stratton-Porter)  
 cf Cuckoo. . . . . 765<sup>a</sup> (Stratton-Porter)
- Sea, The Molten, or  
 Brazen. . . . . 2708<sup>a</sup> (Caldecott)  
 cf Temple. . . . . 2930<sup>a</sup> (Caldecott; Orr)
- Sea-monster. . . . . 2707<sup>a</sup> (Day)  
 cf Dragon. . . . . 873<sup>a</sup> (Day)  
 cf Jackal. . . . . 1548<sup>a</sup> (Day)  
 cf Water-spout. . . . . 3075<sup>a</sup> (Day)  
 cf Whale. . . . . 3082<sup>a</sup> (Day)
- Sea of the Philistines  
 cf Mediterranean Sea. . . . . 2026<sup>b</sup> (Heidel)
- Sea of the Plain (Arabah)  
 cf Dead Sea. . . . . 801<sup>a</sup> (Wright)
- Sea, Red. . . . . 2538<sup>b</sup> (Wright)
- Sea, Salt  
 cf Dead Sea. . . . . 801<sup>a</sup> (Wright)
- Sea of Sodom (Sodomit-  
 ish)  
 cf Dead Sea. . . . . 801<sup>a</sup> (Wright)
- Sea of Tiberias  
 cf Galilee, Sea of. . . . . 1165<sup>a</sup> (Ewing)
- Sea, Western  
 cf Mediterranean Sea. . . . . 2026<sup>b</sup> (Heidel)
- Seah. . . . . 2708<sup>a</sup>  
 cf Weights and Meas-  
 ures. . . . . 3079<sup>a</sup> (Porter)
- Seal. . . . . 2708<sup>a</sup> (Edwards)  
 Among the Hebrews. . . . . 2708<sup>b</sup>  
 Baptism as. . . . . 2709<sup>b</sup>  
 Circumcision as. . . . . 2709<sup>b</sup>  
 Metaphorical use. . . . . 2709<sup>a</sup>  
 cf Mystery. . . . . 2104<sup>a</sup> (Edwards)

- Seal—*continued*  
 Prevalence in an-  
 tiquity . . . . . 2708<sup>a</sup>  
 cf Print . . . . . 2455<sup>a</sup> (Richardson)  
 cf Ring . . . . . 2594<sup>a</sup> (Crannell)  
 cf Sealed Fountain . . . . . 2709<sup>b</sup>  
 cf Text of the Old  
 Testament . . . . . 2957<sup>b</sup> (Weir)  
 Uses of sealing . . . . . 2709<sup>a</sup>  
 Sealed Fountain . . . . . 2709<sup>b</sup>  
 cf Jerusalem . . . . . 1611<sup>a</sup> (Masterman)  
 cf Seal . . . . . 2709<sup>a</sup> (Edwards)  
 Sealskin . . . . . 2709<sup>b</sup>  
 cf Badger . . . . . 376<sup>b</sup> (Day)  
 cf Porpoise . . . . . 2422<sup>a</sup>  
 cf Skin . . . . . 2813<sup>b</sup> (Luering)  
 Seam, Seamless . . . . . 2710<sup>a</sup>  
 Scar . . . . . 2710<sup>a</sup>  
 Search . . . . . 2710<sup>a</sup> (Gerberding)  
 cf Searchings . . . . . 2710<sup>a</sup> (N. Isaacs)  
 Search the Scriptures . . . . . 2710<sup>a</sup> (Harry)  
 Searchings . . . . . 2710<sup>a</sup> (N. Isaacs)  
 cf Search . . . . . 2710<sup>a</sup> (Gerberding)  
 Seasons . . . . . 2710<sup>b</sup> (Joy)  
 cf Astronomy . . . . . 304<sup>a</sup> (Maunder)  
 cf Cold . . . . . 673<sup>b</sup> (Joy)  
 cf Heat . . . . . 1352<sup>a</sup> (Joy)  
 cf Rain . . . . . 2525<sup>b</sup> (Joy)  
 cf Summer . . . . . 2870<sup>a</sup> (Porter)  
 Seat . . . . . 2710<sup>b</sup> (Cotton)  
 cf Stool . . . . . 2862<sup>b</sup> (Cotton)  
 Seats, Chief . . . . . 606<sup>b</sup> (J. M. Wilson)  
 Seba . . . . . 2710<sup>b</sup> (Pinches)  
 cf Sabaeans . . . . . 2629<sup>a</sup> (Pinches)  
 cf Sheba . . . . . 2752<sup>b</sup> (Weir)  
 Sebam . . . . . 2711<sup>a</sup> (Ewing)  
 Sebat  
 cf Shebat . . . . . 2753<sup>b</sup>  
 Secacah . . . . . 2711<sup>a</sup> (Masterman)  
 Sechenias . . . . . 2711<sup>a</sup>  
 cf Shecaniah . . . . . 2754<sup>b</sup> (Wolf)  
 Sechu  
 cf Secu . . . . . 2711<sup>b</sup> (Ewing)  
 Second Advent . . . . . 616<sup>a</sup> (Bevan)  
 Secondarily . . . . . 2711<sup>b</sup>  
 Second Coming  
 cf Eschatology of the  
 NT . . . . . 979<sup>b</sup> (Vos)  
 cf Parousia . . . . . 2249<sup>a</sup> (Easton)  
 Second Death  
 cf Death . . . . . 811<sup>a</sup> (Macalister; Ba-  
 vinck)  
 cf Eschatology of the  
 NT . . . . . 979<sup>b</sup> (Vos)  
 Second Sabbath . . . . . 2634<sup>b</sup> (Baur)  
 Secret . . . . . 2711<sup>b</sup>  
 Sect . . . . . 2711<sup>b</sup> (W. L. Walker)  
 cf Heresy . . . . . 1377<sup>a</sup> (Jacobs)  
 Secu . . . . . 2711<sup>b</sup> (Ewing)  
 Secundus . . . . . 2711<sup>b</sup>  
 Secure, Securely, Security 2711<sup>b</sup> (Dosker)  
 cf Surety . . . . . 2872<sup>a</sup> (Reeve)
- Sedekias (Sedecias) . . . . . 2712<sup>a</sup>  
 Zedechias . . . . . 3141<sup>a</sup>  
 Seditious . . . . . 2712<sup>a</sup>  
 Seduce, Seducer . . . . . 2712<sup>a</sup> (Edwards)  
 cf Crimes . . . . . 745<sup>b</sup> (Hirsch)  
 cf Punishments . . . . . 2504<sup>b</sup> (Hirsch)  
 Seduction . . . . . 748<sup>a</sup> (Hirsch)  
 See . . . . . 2712<sup>b</sup> (M. O. Evans)  
 cf Revelation . . . . . 2573<sup>b</sup> (Warfield)  
 Seed . . . . . 2712<sup>b</sup> (Easton)  
 cf Agriculture . . . . . 75<sup>b</sup> (Patch)  
 cf Clean . . . . . 667<sup>a</sup> (Crannell)  
 cf Regeneration . . . . . 2546<sup>b</sup> (Nuelsen)  
 Seer . . . . . 2713<sup>a</sup> (Orr)  
 cf Prophet, Prophecy . . . . . 2459<sup>b</sup> (Orelli)  
 Seethe . . . . . 2713<sup>a</sup>  
 Segub . . . . . 2713<sup>a</sup> (Wolf)  
 cf Gezer . . . . . 1222<sup>a</sup> (Masterman)  
 Seir . . . . . 2713<sup>a</sup> (Ewing)  
 cf Edom . . . . . 899<sup>a</sup> (Ewing)  
 Seirah . . . . . 2713<sup>a</sup>  
 Seirath  
 cf Seirah . . . . . 2713<sup>a</sup>  
 Sela . . . . . 2713<sup>b</sup> (Ewing)  
 Bozrah of Amos 1 12 . . . . . 2713<sup>b</sup>  
 Commercial impor-  
 tance . . . . . 2714<sup>b</sup>  
 Impressiveness of city  
 of Petra . . . . . 2714<sup>a</sup>  
 cf Joktheel . . . . . 1727<sup>b</sup>  
 Location . . . . . 2713<sup>b</sup>  
 Petra . . . . . 2713<sup>b</sup>  
 cf Stone, Stones . . . . . 2856<sup>a</sup> (Day)  
 Selah . . . . . 2714<sup>b</sup>  
 cf Music . . . . . 2094<sup>b</sup> (Millar)  
 cf Psalms, Book of . . . . . 2488<sup>b</sup> (Sampey)  
 Sela-hammahlekoth . . . . . 2714<sup>b</sup>  
 Seled . . . . . 2714<sup>b</sup>  
 Selemia  
 cf Selemias . . . . . 2714<sup>b</sup>  
 Selemias . . . . . 2714<sup>b</sup>  
 Seleucia . . . . . 2714<sup>b</sup> (Christie)  
 History of . . . . . 2715<sup>a</sup>  
 Port of Antioch . . . . . 2714<sup>b</sup>  
 Ruins of . . . . . 2715<sup>a</sup>  
 Seleucidæ  
 cf Seleucus . . . . . 2715<sup>a</sup> (Hutchison)  
 Seleucus . . . . . 2715<sup>a</sup> (Hutchison)  
 cf Heliodorus . . . . . 1370<sup>b</sup> (Hutchison)  
 Self-control . . . . . 2715<sup>b</sup>  
 Self-denial  
 cf Abstinence . . . . . 24<sup>b</sup> (Eager)  
 Self-righteousness . . . . . 2715<sup>b</sup> (Carver)  
 cf Sanctification . . . . . 2681<sup>b</sup> (Rall)  
 Self-surrender . . . . . 2715<sup>b</sup> (Pollard)  
 In Christ's teaching . . . . . 2716<sup>a</sup>  
 Examples in OT . . . . . 2716<sup>a</sup>  
 Ideal in law and  
 prophets . . . . . 2716<sup>a</sup>  
 Ideal in NT . . . . . 2716<sup>a</sup>  
 Self-will . . . . . 2716<sup>b</sup> (Dosker)

- Sell, Seller  
 of Lydia (country) . . . 1943<sup>a</sup> (Banks)  
 of Trade . . . . . 3002<sup>a</sup> (Easton)  
 Selvedge . . . . . 2716<sup>b</sup>  
 of Clasps . . . . . 665<sup>b</sup> (Caldecott)  
 Sem . . . . . 2717<sup>a</sup>  
 Semachiah . . . . . 2717<sup>a</sup>  
 of Ismachiah . . . . . 1511<sup>b</sup>  
 Semei . . . . . 2717<sup>a</sup>  
 of Shimei . . . . . 2770<sup>b</sup> (Mack)  
 Semeias . . . . . 2717<sup>a</sup>  
 of Shimei . . . . . 2770<sup>b</sup> (Mack)  
 Semein . . . . . 2717<sup>a</sup>  
 Semeis . . . . . 2717<sup>a</sup>  
 of Shimei . . . . . 2770<sup>a</sup> (Mack)  
 Semellius  
 of Samellius . . . . . 2674<sup>a</sup>  
 of Shimshai . . . . . 2771<sup>a</sup> (Wolf)  
 Semiramis . . . . . 350<sup>b</sup> (Pinches)  
 Semis  
 of Semeis . . . . . 2717<sup>a</sup>  
 Semites, Semitic Religion 2717<sup>a</sup> (Mack)  
 of Abraham . . . . . 18<sup>a</sup> (Boyd)  
 of Arphaxad . . . . . 259<sup>b</sup>  
 of Ashtoreth . . . . . 270<sup>b</sup> (Sayce)  
 of Assyria . . . . . 290<sup>b</sup> (Sayce)  
 of Baal . . . . . 345<sup>a</sup> (Sayce)  
 of Babylonia . . . . . 358<sup>b</sup> (Clay)  
 Biblical references . . . . . 2717<sup>a</sup>  
 of Chiun . . . . . 612<sup>a</sup> (Margolis)  
 of Eber . . . . . 890<sup>b</sup> (Grant)  
 Immanence of God . . . . . 2719<sup>a</sup>  
 of Israel, Religion of . . . . . 1530<sup>b</sup> (Orelli)  
 Mixed racially . . . . . 2718<sup>a</sup>  
 of Moloch (Molech) . . . . . 2074<sup>a</sup> (Nicol)  
 Moral character of  
 Deity . . . . . 2719<sup>b</sup>  
 Original home of . . . . . 2717<sup>b</sup>  
 Personality of Deity . . . . . 2719<sup>a</sup>  
 Semitic languages . . . . . 2718<sup>b</sup>  
 Semitic religion . . . . . 2718<sup>b</sup>  
 Sons of Shem . . . . . 2717<sup>b</sup>  
 Table of Gen 10 . . . . . 2718<sup>a</sup>  
 of Table of Nations . . . . . 2898<sup>b</sup> (Pinches)  
 Theism of Semites . . . . . 2719<sup>a</sup>  
 Senaah . . . . . 2719<sup>b</sup> (Ewing)  
 of Hassenuah . . . . . 1342<sup>b</sup>  
 of Sanaas . . . . . 2681<sup>a</sup>  
 Senate, Senator . . . . . 2719<sup>b</sup> (Heidel)  
 of Government . . . . . 1287<sup>a</sup> (Heidel)  
 of Sanhedrin . . . . . 2688<sup>b</sup> (Levertoff)  
 Seneca  
 of Nero . . . . . 2135<sup>a</sup> (Angus)  
 Seneh . . . . . 2720<sup>a</sup> (Ewing)  
 of Bozez . . . . . 512<sup>b</sup> (Ewing)  
 of Michmash . . . . . 2048<sup>a</sup> (Ewing)  
 Senir . . . . . 2720<sup>a</sup> (Ewing)  
 of Hermon . . . . . 1378<sup>a</sup> (Ewing)  
 of Shenir . . . . . 2761<sup>a</sup>  
 Sennacherib . . . . . 2720<sup>a</sup> (Clay); 367<sup>a</sup> (Clay)  
 Campaign against Judah . . . . . 2720<sup>b</sup>  
 Sennacherib—*continued*  
 Early campaigns . . . . . 2720<sup>a</sup>  
 Later years and death 2720<sup>b</sup>  
 Name and rise . . . . . 2720<sup>a</sup>  
 of Nineveh . . . . . 2149<sup>a</sup> (Pinches)  
 of Sharezer . . . . . 2750<sup>a</sup> (Eiselen)  
 Senses . . . . . 2720<sup>b</sup> (W. L. Walker)  
 Sensual . . . . . 2721<sup>a</sup> (Pratt)  
 of Psychology . . . . . 2494<sup>b</sup> (Marais)  
 Sent . . . . . 2721<sup>a</sup> (W. L. Walker)  
 of Siloam . . . . . 2791<sup>a</sup> (Masterman)  
 Sentence . . . . . 2721<sup>a</sup>  
 Senuah . . . . . 2721<sup>a</sup>  
 of Hassenuah . . . . . 1342<sup>b</sup>  
 Seorim . . . . . 2721<sup>a</sup>  
 Separate . . . . . 2721<sup>b</sup>  
 of Nazirite . . . . . 2124<sup>a</sup> (Christie)  
 of Saints . . . . . 2661<sup>a</sup> (Estes)  
 Separation . . . . . 2721<sup>b</sup>  
 of Heifer, Red . . . . . 1367<sup>b</sup> (Easton)  
 of Nazirite . . . . . 2124<sup>a</sup> (Christie)  
 of Uncleanness . . . . . 3035<sup>b</sup> (Williams)  
 Sephar . . . . . 2721<sup>b</sup> (Fulton)  
 Sepharad . . . . . 2721<sup>b</sup> (Orr)  
 Sepharvaim . . . . . 2721<sup>b</sup> (Pinches)  
 of Ivvah . . . . . 1544<sup>b</sup> (Pinches)  
 of Sepharvites . . . . . 2722<sup>a</sup>  
 Sepharvites . . . . . 2722<sup>a</sup>  
 of Sepharvaim . . . . . 2721<sup>b</sup> (Pinches)  
 Sepphoris . . . . . 2722<sup>a</sup>  
 Septuagint . . . . . 2722<sup>a</sup> (Thackeray); 461<sup>b</sup> (Orr); 457<sup>b</sup> (Dosker); 857<sup>b</sup> (Nicol)  
 Characteristics of the  
 LXX . . . . . 2729<sup>b</sup>  
 General features . . . . . 2731<sup>a</sup>  
 Grouping on internal  
 evidence . . . . . 2729<sup>b</sup>  
 Hexateuch, the . . . . . 2729<sup>b</sup>  
 Latest LXX translations . . . . . 2730<sup>b</sup>  
 "Latter" prophets . . . . . 2730<sup>a</sup>  
 "Writings," the . . . . . 2730<sup>b</sup>  
 Differences between  
 Greek and Hebrew  
 texts . . . . . 2731<sup>a</sup>  
 Sequence . . . . . 2731<sup>a</sup>  
 Subject-matter . . . . . 2731<sup>b</sup>  
 Evidence of prologue  
 to Sirach . . . . . 2724<sup>b</sup>  
 Importance . . . . . 2722<sup>a</sup>  
 Based on early text 2722<sup>b</sup>  
 Bible of the early  
 church . . . . . 2722<sup>b</sup>  
 of Jeremiah . . . . . 1591<sup>a</sup> (Orelli)  
 of Jeroboam I . . . . . 1593<sup>a</sup> (Mosiman)  
 of Manuscripts . . . . . 1984<sup>a</sup> (Richardson)  
 Name . . . . . 2722<sup>b</sup>  
 Number, titles and order of books . . . . . 2728<sup>b</sup>  
 Contents . . . . . 2728<sup>b</sup>

Septuagint—*continued*

- Number, titles and order of books—*continued*  
 Grouping and order  
 of books . . . . . 2729<sup>a</sup>  
 Titles . . . . . 2729<sup>a</sup>  
 of Papyrus . . . . . 2241<sup>a</sup> (Goodspeed)  
 of Pentateuch . . . . . 2302<sup>a</sup> (Wiener)  
 of Ptolemy . . . . . 2499<sup>b</sup> (Angus)  
 Reconstruction of text. 2727<sup>b</sup>  
 Ancient versions . . . 2727<sup>b</sup>  
 Coptic, Ethiopic and  
 Syriac . . . . . 2727<sup>b</sup>  
 Manuscripts . . . . . 2728<sup>a</sup>  
 Printed texts . . . . . 2728<sup>a</sup>  
 Reconstruction of  
 the original text . . 2728<sup>b</sup>  
 of Text and Manu-  
 scripts of the NT . . . 2950<sup>b</sup> (Sitterly)  
 of Text of the OT . . . 2960<sup>a</sup> (Weir)  
 Traditional origin . . . 2723<sup>a</sup>  
 Christian views . . . . 2723<sup>b</sup>  
 Evidence of Aristo-  
 bulus and Philo . . . 2723<sup>a</sup>  
 Letter of Aristeas . . . 2723<sup>a</sup>  
 Transmission of LXX  
 text . . . . . 2724<sup>b</sup>  
 Aquila . . . . . 2725<sup>b</sup>  
 Hesychius . . . . . 2727<sup>a</sup>  
 Lucian . . . . . 2727<sup>a</sup>  
 Official revision of  
 Hebrew . . . . . 2725<sup>a</sup>  
 Origen and the Hexa-  
 pla . . . . . 2726<sup>a</sup>  
 Symmachus . . . . . 2726<sup>a</sup>  
 Theodotion . . . . . 2725<sup>b</sup>  
 of Versions, Georgian . 3048<sup>a</sup> (Easton)  
 of Writing . . . . . 3121<sup>a</sup> (Richardson)  
 Sepulchre . . . . . 2732<sup>a</sup>  
 of Burial . . . . . 529<sup>a</sup> (Eager)  
 of Jerusalem . . . . . 1611<sup>b</sup> (Masterman)  
 Serah . . . . . 2732<sup>a</sup>  
 Seraiah . . . . . 2732<sup>a</sup> (Wolf)  
 of Azarias . . . . . 342<sup>a</sup>  
 of Saraias . . . . . 2691<sup>b</sup>  
 Seraphim . . . . . 2732<sup>a</sup> (Carver)  
 Serar . . . . . 2732<sup>b</sup>  
 of Sisera . . . . . 2812<sup>b</sup> (Schenk)  
 Sere . . . . . 2732<sup>b</sup>  
 Sergius Paulus . . . . . 2292<sup>b</sup> (Kerr)  
 Serjeants . . . . . 2732<sup>b</sup>  
 Sermon on the Mount,  
 The . . . . . 2732<sup>b</sup> (Miller)  
 Analysis . . . . . 2734<sup>a</sup>  
 of Beatitudes . . . . . 419<sup>a</sup> (Lambert)  
 of Ethics . . . . . 1013<sup>a</sup> (Alexander)  
 of Ethics of Jesus . . . 1026<sup>a</sup> (Stalker)  
 Heavens . . . . . 2733<sup>b</sup>  
 Historicity . . . . . 2733<sup>a</sup>  
 of Jesus Christ . . . . . 1642<sup>b</sup> (Orr)  
 Kingdom of God . . . . 2734<sup>a</sup>  
 of Kingdom of God. 1805<sup>a</sup> (Stalker)  
 Message, the . . . . . 2733<sup>b</sup>

- Sermon on the Mount, The—*continued*  
 Motive and conduct . . 2735<sup>a</sup>  
 New righteousness, the 2734<sup>b</sup>  
 Parallels . . . . . 2732<sup>a</sup>  
 Principles . . . . . 2735<sup>b</sup>  
 Scene . . . . . 2733<sup>b</sup>  
 of Sermon on the Plain,  
 The . . . . . 2736<sup>a</sup> (Miller)  
 Time and occasion . . . 2733<sup>a</sup>  
 Sermon on the Plain,  
 The . . . . . 2736<sup>a</sup> (Miller)  
 of Sermon on the  
 Mount, The . . . . . 2732<sup>b</sup> (Miller)  
 Seron . . . . . 2736<sup>a</sup>  
 Serpent . . . . . 2736<sup>a</sup> (Day)  
 of Adder . . . . . 55<sup>a</sup> (Day)  
 Biblical names . . . . . 2737<sup>a</sup>  
 of Bittern . . . . . 484<sup>a</sup> (Stratton-Porter)  
 Figurative use . . . . . 2738<sup>a</sup>  
 of Hedgehog . . . . . 1367<sup>a</sup>  
 of Jerusalem . . . . . 1610<sup>b</sup> (Masterman)  
 In the Orient . . . . . 2736<sup>a</sup>  
 of Owl . . . . . 2205<sup>b</sup> (Stratton-Porter)  
 In Palestine . . . . . 2736<sup>b</sup>  
 of Porcupine . . . . . 2421<sup>b</sup> (Day)  
 of Reptile . . . . . 2561<sup>a</sup>  
 of Viper . . . . . 3051<sup>b</sup>  
 Serpent, Brazen  
 of Nehushtan . . . . . 2132<sup>a</sup> (Longacre)  
 Serpent-charming . . . . 2738<sup>b</sup>  
 Serpent, Crooked . . . . 2738<sup>b</sup>  
 of Astronomy . . . . . 300<sup>b</sup> (Maunder)  
 Serpent, Fiery  
 of Nehushtan . . . . . 2132<sup>a</sup> (Longacre)  
 of Serpent . . . . . 2736<sup>a</sup> (Day)  
 Serpent Worship . . . . . 2738<sup>b</sup> (Orr)  
 of Nehushtan . . . . . 2132<sup>a</sup> (Longacre)  
 Serug . . . . . 2738<sup>b</sup>  
 of Saruch . . . . . 2693<sup>b</sup>  
 Servant . . . . . 2738<sup>b</sup> (McGlothlin)  
 of Manservant . . . . . 1983<sup>b</sup>  
 of Slave, Slavery . . . . 2815<sup>a</sup> (Raffety)  
 Servant of Jehovah (The  
 Lord) . . . . . 2739<sup>a</sup> (Hough)  
 Date of Servant sec-  
 tions . . . . . 2740<sup>a</sup>  
 Historical situation . . . 2739<sup>a</sup>  
 Ideas of Isaiah 40-66 . . 2739<sup>b</sup>  
 of Isaiah . . . . . 1495<sup>b</sup> (Robinson)  
 of Mediation, Medi-  
 ator . . . . . 2020<sup>b</sup> (Edwards)  
 of Messiah . . . . . 2041<sup>a</sup> (Crichton)  
 Messianic significance . 2742<sup>b</sup>  
 Not by Prophet Isaiah 2739<sup>a</sup>  
 Personality of Servant. 2741<sup>a</sup>  
 Place in OT . . . . . 2742<sup>a</sup>  
 Psychology of the  
 prophecy . . . . . 2742<sup>a</sup>  
 Servant passages . . . . 2740<sup>a</sup>  
 Unity of Second Isaiah 2739<sup>b</sup>  
 Servants, Solomon's . . . 2825<sup>b</sup> (Mack)

- Service . . . . . 2742<sup>b</sup> (Raffety)  
 of Servant . . . . . 2738<sup>b</sup> (McGlothlin)
- Serving-women  
 of Priests and Levites . 2446<sup>b</sup> (Wiener)
- Servitude  
 of Servant . . . . . 2738<sup>b</sup> (McGlothlin)  
 of Slave, Slavery . . . . . 2815<sup>a</sup> (Raffety)
- Sesis . . . . . 2743<sup>a</sup>  
 of Shashai . . . . . 2751<sup>a</sup>
- Sesthel . . . . . 2743<sup>a</sup>  
 of Bezalel . . . . . 459<sup>b</sup> (Farr)
- Set . . . . . 2743<sup>a</sup> (Dosker)
- Seth, Sheth . . . . . 2743<sup>b</sup> (S. F. Hunter); 139<sup>b</sup>
- Sethur . . . . . 2743<sup>b</sup>
- Setting . . . . . 2743<sup>b</sup>
- Settle (noun) . . . . . 2743<sup>b</sup>  
 of Temple . . . . . 2930<sup>a</sup> (Caldecott; Orr)
- Settle (verb) . . . . . 2743<sup>b</sup> (Dosker)
- Seven . . . . . 2743<sup>b</sup>  
 of Number . . . . . 2159<sup>b</sup> (Smith); 2160<sup>a</sup>  
 (Smith)
- Seven Churches  
 of Angels of Seven  
 Churches . . . . . 135<sup>b</sup> (Banks)
- Sevneh . . . . . 2744<sup>a</sup>  
 of Aramaic Language . 222<sup>a</sup> (J. E. H. Thomson)  
 of Egypt . . . . . 906<sup>a</sup> (Petrie)  
 of Papyrus . . . . . 2238<sup>b</sup> (Goodspeed)  
 of Sanctuary . . . . . 2686<sup>b</sup> (Wiener)
- Seven Princes  
 of Carshena . . . . . 580<sup>b</sup>  
 of Prince . . . . . 2453<sup>a</sup> (Baur)
- Seven Stars  
 of Astronomy . . . . . 300<sup>b</sup> (Maunder)
- Seventh Day  
 of Sabbath . . . . . 2629<sup>b</sup> (Sampey)
- Seventy . . . . . 2744<sup>a</sup>  
 of Number . . . . . 2157<sup>a</sup> (Smith)
- Seventy Disciples . . . . . 2744<sup>a</sup> (Carver)
- Seventy Weeks . . . . . 2744<sup>a</sup> (Orr)  
 of Daniel . . . . . 782<sup>b</sup> (R. D. Wilson)
- Seventy Years . . . . . 2744<sup>b</sup>  
 of Captivity . . . . . 569<sup>b</sup> (Nicol)
- Sever . . . . . 2744<sup>b</sup>
- Several, Severally . . . . . 2744<sup>b</sup>
- Shaalabbin . . . . . 2745<sup>a</sup>
- Shaalbim . . . . . 2745<sup>a</sup> (Ewing)
- Shaalbonite . . . . . 2745<sup>a</sup>
- Shaalim, Land of . . . . . 2745<sup>a</sup> (Ewing)
- Shaaph . . . . . 2745<sup>a</sup>
- Shaaraim . . . . . 2745<sup>a</sup> (Masterman)  
 of Shilhim . . . . . 2768<sup>b</sup>
- Shaashgaz . . . . . 2745<sup>b</sup>
- Shabbethai . . . . . 2745<sup>b</sup> (Wolf)  
 of Sabbateus . . . . . 2629<sup>b</sup>
- Shachia . . . . . 2745<sup>b</sup>
- Shaddai  
 of God, Names of . . . . . 1264<sup>b</sup> (Mack)
- Shade, Shadow, Shadow-  
 ing . . . . . 2745<sup>b</sup> (W. L. Walker)  
 of Shadow of Death . . . 2746<sup>a</sup> (W. L. Walker)
- Shadow of Death . . . . . 2746<sup>a</sup> (W. L. Walker)
- Shadrach . . . . . 2746<sup>a</sup> (R. D. Wilson)  
 of Abednego . . . . . 4<sup>b</sup> (R. D. Wilson)  
 of Hananiah . . . . . 1333<sup>b</sup> (Reeve)  
 of Meshach . . . . . 2038<sup>a</sup> (R. D. Wilson)  
 of Song of Three Chil-  
 dren . . . . . 2834<sup>a</sup> (T. W. Davies)
- Shady Trees . . . . . 2746<sup>b</sup>  
 of Lotus Trees . . . . . 1931<sup>b</sup> (Masterman)
- Shaft . . . . . 2746<sup>b</sup>  
 of Archery . . . . . 233<sup>b</sup> (Eager)  
 of Armor, Arms . . . . . 251<sup>a</sup> (Nicol)
- Shagee . . . . . 2746<sup>b</sup>
- Shaharaim . . . . . 2746<sup>b</sup>
- Shahazumah . . . . . 2746<sup>b</sup>
- Shalem . . . . . 2746<sup>b</sup> (Ewing)
- Shalim  
 of Shaalim, Land of . . . 2745<sup>a</sup> (Ewing)
- Shalishah, Land of . . . . . 2746<sup>b</sup> (Ewing)
- Shallecheth . . . . . 2747<sup>a</sup> (Masterman)
- Shallum (general) . . . . . 2747<sup>a</sup> (Umbach)  
 of Jehoahaz . . . . . 1575<sup>a</sup> (Genung)  
 of Jeroboam II . . . . . 1594<sup>a</sup> (Caldecott)  
 of Meshelemiah . . . . . 2038<sup>b</sup>  
 of Meshullam . . . . . 2038<sup>b</sup> (Lees)  
 of Salem (person) . . . . 2663<sup>a</sup>  
 of Salemas . . . . . 2663<sup>a</sup>  
 of Sallumus . . . . . 2663<sup>b</sup>  
 of Salom . . . . . 2664<sup>a</sup>  
 of Salum . . . . . 2665<sup>a</sup>  
 of Shillem, Shillemites 2768<sup>b</sup>
- Shallum (king) . . . . . 2747<sup>a</sup> (Caldecott)
- Shallun . . . . . 2747<sup>b</sup>
- Shalmai . . . . . 2747<sup>b</sup>  
 of Salmal . . . . . 2663<sup>b</sup>
- Shalman . . . . . 2747<sup>b</sup> (Eiselen)  
 of Beth-arbel . . . . . 443<sup>a</sup> (Ewing)
- Shalmaneser . . . . . 2747<sup>b</sup> (Nicol)  
 of Assyria . . . . . 290<sup>b</sup> (Sayce); 437<sup>a</sup> (Nicol)  
 of Jehu . . . . . 1586<sup>a</sup> (Caldecott)  
 of Syria . . . . . 2882<sup>b</sup> (Christie)  
 Western campaigns . . . . . 570<sup>a</sup>; 571<sup>a</sup> (Nicol)
- Shama . . . . . 2748<sup>a</sup>
- Shamai  
 of Salmal . . . . . 2663<sup>b</sup>
- Shamariah  
 of Shemariah . . . . . 2760<sup>b</sup> (Wolf)
- Shamash . . . . . 371<sup>a</sup> (Rogers)
- Shambles . . . . . 2748<sup>a</sup>
- Shame . . . . . 2748<sup>a</sup> (Stuart)
- Shamed (Shemed)  
 of Shemer . . . . . 2760<sup>b</sup> (Wolf)
- Shamefacedness  
 of Shamefastness . . . . . 2748<sup>b</sup>
- Shamefastness . . . . . 2748<sup>b</sup>
- Shamer  
 of Shemer . . . . . 2760<sup>b</sup> (Wolf)
- Shamgar . . . . . 2748<sup>b</sup> (E. D. Isaacs)
- Shamhuth  
 of Shammua, Sham-  
 muah . . . . . 2749<sup>b</sup>
- Shamir (person) . . . . . 2749<sup>a</sup>

- Shamir (places) . . . . . 2749<sup>a</sup> (Masterman)  
 Shamlai  
   cf Salmi . . . . . 2663<sup>b</sup>  
   cf Subai . . . . . 2868<sup>a</sup>  
 Shamma . . . . . 2749<sup>a</sup>  
 Shammah . . . . . 2749<sup>a</sup> (Wolf)  
   cf Harod, Well of . . . . . 1340<sup>b</sup> (Ewing)  
   cf Shimea . . . . . 2769<sup>b</sup>  
   cf Shimei . . . . . 2770<sup>a</sup> (Mack)  
 Shammai . . . . . 2749<sup>b</sup>  
 Shammoth  
   cf Shammah . . . . . 2749<sup>a</sup> (Wolf)  
 Shammua, Shammuah . . . . . 2749<sup>b</sup>  
   cf Shemaiah . . . . . 2759<sup>b</sup> (Wolf)  
   cf Shimea . . . . . 2769<sup>b</sup>  
 Shamsherai . . . . . 2749<sup>b</sup>  
 Shape . . . . . 2749<sup>b</sup> (Luring)  
 Shapham . . . . . 2749<sup>b</sup>  
 Shaphan . . . . . 2749<sup>b</sup> (Wolf)  
   cf Totemism . . . . . 3000<sup>a</sup> (M. O. Evans)  
 Shaphat . . . . . 2750<sup>a</sup>  
 Shapher  
   cf Shepher . . . . . 2763<sup>a</sup>  
 Shaphir . . . . . 2750<sup>a</sup> (Masterman)  
 Sharai . . . . . 2750<sup>a</sup>  
 Sharaim  
   cf Shaaraim . . . . . 2745<sup>a</sup> (Masterman)  
 Sharar  
   cf Sacar . . . . . 2636<sup>a</sup>  
 Share  
   cf Plow . . . . . 2409<sup>a</sup> (Patch)  
 Sharezer . . . . . 2750<sup>a</sup> (Eiselen)  
   cf Adrammelech . . . . . 61<sup>b</sup> (Beecher)  
   cf Regem-melech . . . . . 2546<sup>b</sup>  
   cf Sennacherib . . . . . 2720<sup>a</sup> (Clay)  
 Sharon . . . . . 2750<sup>b</sup> (Ewing)  
   cf Lasharon . . . . . 1840<sup>a</sup>  
   cf Saron . . . . . 2693<sup>a</sup>  
 Sharonite . . . . . 2751<sup>a</sup>  
   cf Sharon . . . . . 2750<sup>b</sup> (Ewing)  
   cf Shitrai . . . . . 2778<sup>b</sup>  
 Sharuhem . . . . . 2751<sup>a</sup>  
   cf Shaaraim . . . . . 2745<sup>a</sup> (Masterman)  
   cf Shilhim . . . . . 2768<sup>b</sup>  
 Shashai . . . . . 2751<sup>a</sup>  
   cf Sesis (Apoc) . . . . . 2743<sup>a</sup>  
 Shashak . . . . . 2751<sup>a</sup>  
 Shaul, Shaulites . . . . . 2751<sup>a</sup>  
 Shaveh-kiriathaim . . . . . 2751<sup>b</sup>  
 Shaveh, Vale of . . . . . 2751<sup>b</sup>  
   cf King's Vale . . . . . 1808<sup>a</sup> (Masterman)  
 Shaving . . . . . 2751<sup>b</sup> (Orr)  
 Shavsha . . . . . 2751<sup>b</sup> (Wolf)  
   cf Sheva . . . . . 2766<sup>b</sup>  
 Shawl . . . . . 2752<sup>a</sup>  
   cf Dress . . . . . 875<sup>b</sup> (Eager)  
 Sheaf, Sheaves . . . . . 2752<sup>a</sup> (Patch)  
   cf Agriculture . . . . . 75<sup>b</sup> (Patch)  
 Sheal . . . . . 2752<sup>a</sup>  
 Shealtiel . . . . . 2752<sup>a</sup>  
   cf Salathiel (Apoc) . . . . . 2662<sup>b</sup>
- Shear  
   cf Sheep . . . . . 2756<sup>b</sup> (Day)  
   cf Sheep Tending . . . . . 2758<sup>a</sup> (Patch)  
 Sheariah . . . . . 2752<sup>b</sup>  
 Shearing House . . . . . 2752<sup>b</sup>  
 Shear-jashub . . . . . 2752<sup>b</sup>  
   cf Immanuel . . . . . 1457<sup>b</sup> (A. W. Evans)  
   cf Jashub . . . . . 1571<sup>a</sup>  
   cf Jushab-hesed . . . . . 1781<sup>b</sup>  
   cf Maher-shalal-hash-  
     baz . . . . . 1967<sup>a</sup>  
 Sheath  
   cf Sword . . . . . 252<sup>b</sup> (Nicol)  
 Sheba (person and tribe) . . . . . 2752<sup>b</sup> (Weir)  
   Arabian tribe . . . . . 2752<sup>b</sup>  
   Civilization . . . . . 2753<sup>a</sup>  
   History . . . . . 2752<sup>b</sup>  
   Religion . . . . . 2753<sup>a</sup>  
   cf Sabacans . . . . . 2629<sup>a</sup> (Pinches)  
   cf Seba . . . . . 2710<sup>b</sup> (Pinches)  
   cf Uz . . . . . 3042<sup>b</sup> (Weir)  
 Sheba (place) . . . . . 2753<sup>a</sup> (Masterman)  
   cf Shema (place) . . . . . 2759<sup>b</sup> (Masterman)  
 Sheba, Queen of . . . . . 2514<sup>b</sup> (Roberts)  
 Shebah  
   cf Shibah . . . . . 2767<sup>b</sup>  
 Shebam  
   cf Sebam . . . . . 2711<sup>a</sup> (Ewing)  
 Shebaniah . . . . . 2753<sup>b</sup>  
   cf Shecaniah . . . . . 2754<sup>b</sup> (Wolf)  
 Shebarim . . . . . 2753<sup>b</sup>  
   cf Quarries . . . . . 2512<sup>b</sup> (Day)  
 Shebat . . . . . 2753<sup>b</sup>  
   cf Calendar . . . . . 541<sup>b</sup> (Porter)  
 Sheber . . . . . 2753<sup>b</sup>  
 Shebna . . . . . 2753<sup>b</sup> (Roberts)  
   cf Eliakim . . . . . 929<sup>a</sup> (S. F. Hunter)  
   Reference in Isaiah 22 . . . . . 2753<sup>b</sup>  
   Reference in 2 K 18 . . . . . 2754<sup>a</sup>  
   Relation of the two  
     references . . . . . 2754<sup>a</sup>  
   cf Zabud . . . . . 3128<sup>b</sup> (Roberts)  
 Shebuel . . . . . 2754<sup>b</sup>  
   cf Shubael . . . . . 2781<sup>a</sup>  
 Shecaniah, Shechaniah . . . . . 2754<sup>b</sup> (Wolf)  
   cf Sechenias (Apoc) . . . . . 2711<sup>a</sup>  
   cf Shebaniah . . . . . 2753<sup>b</sup>  
 Shechem . . . . . 2755<sup>a</sup> (Ewing)  
   Israelite history . . . . . 2755<sup>b</sup>  
   cf Jacob's Well . . . . . 1556<sup>a</sup> (Ewing)  
   Location and features . . . . . 2756<sup>a</sup>  
   Modern Shechem . . . . . 2756<sup>a</sup>  
   Patriarchal history . . . . . 2755<sup>a</sup>  
   cf Refuge, Cities of . . . . . 2545<sup>b</sup> (Ewing)  
   cf Sychar . . . . . 2876<sup>b</sup> (Ewing)  
 Shechemites . . . . . 2756<sup>b</sup>  
 Shed, Shedding . . . . . 2756<sup>b</sup> (Dosker)  
 Shedeur . . . . . 2756<sup>b</sup>  
 Sheep . . . . . 2756<sup>b</sup> (Day)  
   Care of . . . . . 2757<sup>a</sup>  
   cf Cattle . . . . . 583<sup>b</sup> (Day)  
   cf Ewe . . . . . 1049<sup>a</sup> (Day)

- Sheep—*continued*  
   Figurative references . . . 2757<sup>b</sup>  
   of Food . . . . . 1123<sup>b</sup> (Eager)  
   of Herdsman . . . . . 1375<sup>b</sup> (Patch)  
   of Lamb . . . . . 1822<sup>b</sup> (Day)  
   Names . . . . . 2756<sup>b</sup>  
   OT references . . . . . 2757<sup>a</sup>  
   of Ram (animal) . . . . . 2527<sup>b</sup>  
   Sheep of Palestine . . . . . 2756<sup>b</sup>  
   of Shepherd . . . . . 2763<sup>a</sup> (Patch)  
   Species . . . . . 2756<sup>b</sup>  
 Sheepcote, Sheepfold . . . . . 2757<sup>b</sup> (Patch)  
 Sheep Gate . . . . . 2758<sup>a</sup>  
   of Bethesda . . . . . 444<sup>b</sup> (Masterman)  
   of Jerusalem Gates . . . . . 1597<sup>b</sup> (Masterman)  
   of Sheep Market . . . . . 2758<sup>a</sup>  
 Sheep Market . . . . . 2758<sup>a</sup>  
   of Bethesda . . . . . 444<sup>b</sup> (Masterman)  
   of Sheep Gate . . . . . 2758<sup>a</sup>  
 Sheep-master . . . . . 2758<sup>a</sup>  
   of Sheep-shearing . . . . . 2758<sup>a</sup> (Patch)  
 Sheep-raising  
   of Agriculture . . . . . 78<sup>a</sup> (Patch)  
   of Herdsman . . . . . 1375<sup>b</sup> (Patch)  
 Sheep-shearing . . . . . 2758<sup>a</sup> (Patch)  
 Sheepskin  
   of Bottle . . . . . 509<sup>b</sup> (Eager)  
   of Dress . . . . . 875<sup>b</sup> (Eager)  
   of Rams' Skins . . . . . 2530<sup>a</sup>  
 Sheep Tending . . . . . 2758<sup>a</sup> (Patch)  
 Sheerah . . . . . 2758<sup>a</sup>  
 Sheet . . . . . 2758<sup>a</sup>  
 Shehariah . . . . . 2758<sup>a</sup>  
 Shekel . . . . . 2758<sup>a</sup> (Porter)  
   of Money . . . . . 2076<sup>a</sup> (Porter)  
   of Shekel of the Sanctu-  
   ary or Sacred Shekel . . . . . 2758<sup>b</sup>  
   of Stater . . . . . 2850<sup>a</sup>  
   of Weights and Meas-  
   ures . . . . . 3079<sup>a</sup> (Porter)  
 Shekel of the King's  
   Weight or Royal  
   Shekel . . . . . 2758<sup>b</sup>  
   of Weights and Meas-  
   ures . . . . . 3079<sup>a</sup> (Porter)  
 Shekel of the Sanctuary  
   or Sacred Shekel . . . . . 2758<sup>b</sup>  
   of Shekel . . . . . 2758<sup>a</sup> (Porter)  
 Shekinah . . . . . 2758<sup>b</sup>  
   of Glory . . . . . 1235<sup>b</sup> (Betteridge)  
 Shelah . . . . . 2758<sup>b</sup>  
   of Sala, Salah . . . . . 2662<sup>a</sup>  
   of Siloam . . . . . 2791<sup>a</sup> (Masterman)  
 Shelah, Pool of  
   of Jerusalem . . . . . 1601<sup>b</sup>; 1606<sup>b</sup> (Master-  
   man)  
 Shelanites  
   of Shelah . . . . . 2758<sup>b</sup>  
 Shelemiah . . . . . 2758<sup>b</sup> (Wolf)  
   of Meshelemiah . . . . . 2038<sup>b</sup>  
 Sheleph . . . . . 2759<sup>a</sup>  
 Shelesh . . . . . 2759<sup>a</sup>  
 Shelomi . . . . . 2759<sup>a</sup>  
 Shelomith . . . . . 2759<sup>a</sup> (Wolf)  
   of Salimoth (Apoc) . . . . . 2663<sup>b</sup>  
 Shelomoth . . . . . 2759<sup>a</sup>  
 Shelumiel . . . . . 2759<sup>a</sup> (Wolf)  
   of Salamiel (Apoc) . . . . . 2662<sup>a</sup>  
 Shem . . . . . 2759<sup>a</sup> (Pinches)  
   of Ham (person) . . . . . 1323<sup>b</sup> (Pinches)  
   of Ham (place) . . . . . 1324<sup>a</sup> (Ewing)  
   of Japheth . . . . . 1568<sup>b</sup> (Pinches)  
   of Table of Nations . . . . . 2898<sup>b</sup> (Pinches)  
 Shema (persons) . . . . . 2759<sup>b</sup> (Wolf)  
   of Sammu (Apoc) . . . . . 2674<sup>b</sup>  
   of Shimei . . . . . 2770<sup>a</sup> (Mack)  
 Shema (place) . . . . . 2759<sup>b</sup> (Masterman)  
   of Sheba . . . . . 2753<sup>a</sup> (Masterman)  
 Shemaah . . . . . 2759<sup>b</sup>  
 Shemaiah . . . . . 2759<sup>b</sup> (Wolf)  
   of Maasmas (Apoc) . . . . . 1946<sup>a</sup>  
   of Sabbeus (Apoc) . . . . . 2636<sup>a</sup>  
   of Samaias (Apoc) . . . . . 2671<sup>a</sup> (Angus)  
   of Sameus (Apoc) . . . . . 2674<sup>a</sup>  
   of Shammua, Sham-  
   muah . . . . . 2749<sup>b</sup>  
 Shemariah . . . . . 2760<sup>b</sup> (Wolf)  
 Shemeber . . . . . 2760<sup>b</sup>  
   of Shinab . . . . . 2771<sup>a</sup> (Wolf)  
 Shemed  
   of Shemer . . . . . 2760<sup>b</sup> (Wolf)  
 Shemer . . . . . 2760<sup>b</sup> (Wolf)  
   of Shomer . . . . . 2779<sup>b</sup>  
 Shemida, Shemidah, She-  
   midaites . . . . . 2760<sup>b</sup>  
 Sheminit  
   of Music . . . . . 2094<sup>b</sup> (Millar)  
   of Psalms, Book of . . . . . 2487<sup>a</sup> (Sampey)  
 Shemiramoth . . . . . 2761<sup>a</sup> (Wolf)  
 Shemites  
   of Semites . . . . . 2717<sup>a</sup> (Mack)  
 Shemuel . . . . . 2761<sup>a</sup>  
   of Samuel . . . . . 2677<sup>a</sup> (Geden)  
 Shen . . . . . 2761<sup>a</sup>  
 Shenazar  
   of Shenazzar . . . . . 2761<sup>a</sup>  
 Shenazzar . . . . . 2761<sup>a</sup>  
   of Sanabassar, Sana-  
   bassar . . . . . 2681<sup>a</sup> (Angus)  
 Shenir . . . . . 2761<sup>a</sup>  
   of Senir . . . . . 2720<sup>a</sup> (Ewing)  
 Sheol . . . . . 2761<sup>a</sup> (Orr)  
   Abode of the dead . . . . . 2761<sup>b</sup>  
   of Abraham's Bosom . . . . . 22<sup>b</sup> (Orr)  
   of Death . . . . . 811<sup>a</sup> (Macalister; Bavinck)  
   of Eschatology of the  
   OT . . . . . 972<sup>a</sup> (Orr)  
   of Hades . . . . . 1314<sup>b</sup> (Vos)  
   of Hell . . . . . 1371<sup>a</sup> (Orr)  
   of Immortal . . . . . 1458<sup>b</sup> (Orr)  
   Name . . . . . 2761<sup>a</sup>  
   Not out of God's rule . . . . . 2761<sup>b</sup>  
   Not state of uncon-  
   sciousness . . . . . 2761<sup>b</sup>



- Sheol—*continued*  
 Post-canonical development . . . . . 2762<sup>a</sup>  
 Relation to future life . 2761<sup>b</sup>  
 cf Resurrection . . . . . 2562<sup>a</sup> (Easton)  
 cf Retribution . . . . . 2570<sup>a</sup> (M'Caig)
- Shepham . . . . . 2762<sup>a</sup>
- Shephatiah . . . . . 2762<sup>a</sup> (Orr)  
 cf Saphat (Apoc) . . . . . 2690<sup>b</sup>  
 cf Saphatias (Apoc) . . . . . 2690<sup>b</sup>  
 cf Saphuthi (Apoc) . . . . . 2690<sup>b</sup>
- Shephelah . . . . . 2762<sup>a</sup> (Ewing)  
 Districts and features . 2762<sup>b</sup>  
 Five valleys . . . . . 2762<sup>b</sup>  
 cf Judah, Territory of . 1763<sup>a</sup> (Masterman)  
 cf Lowland . . . . . 1934<sup>b</sup> (Day)  
 Meaning and references . . . . . 2762<sup>a</sup>  
 cf Vale . . . . . 3045<sup>a</sup> (Day)
- Shepher . . . . . 2763<sup>a</sup>  
 cf Wanderings of Israel . 3064<sup>a</sup> (Conder)
- Shepherd . . . . . 2763<sup>a</sup> (Patch)  
 Biblical references . . . . . 2763<sup>a</sup>  
 Duties of . . . . . 2763<sup>b</sup>  
 Equipment of . . . . . 2764<sup>a</sup>  
 Figurative references . 2764<sup>a</sup>  
 Jesus as . . . . . 2764<sup>a</sup>  
 cf Sheep . . . . . 2756<sup>b</sup> (Day)  
 cf Staff . . . . . 2847<sup>b</sup>
- Shephi, Shepho . . . . . 2764<sup>a</sup>
- Shephupham, Shephuphan . . . . . 2764<sup>a</sup>  
 cf Muppim . . . . . 2094<sup>a</sup>  
 cf Shuppim . . . . . 2782<sup>a</sup>
- Sherah . . . . .  
 cf Sheerah . . . . . 2758<sup>a</sup>
- Sherd . . . . .  
 cf Potsherd . . . . . 2423<sup>b</sup>
- Sherebiah . . . . . 2764<sup>b</sup> (Wolf)  
 cf Asebebias (Apoc) . . . . . 266<sup>b</sup>  
 cf Sarabias (Apoc) . . . . . 2690<sup>b</sup>
- Sheresh . . . . . 2764<sup>b</sup>
- Sherezer . . . . .  
 cf Sharezer . . . . . 2750<sup>a</sup> (Eiselen)
- Sherghat, or Asshur or Assur . . . . . 2764<sup>b</sup> (Banks)  
 cf Assyria . . . . . 290<sup>b</sup> (Sayce)  
 Excavations at . . . . . 2765<sup>a</sup>  
 First capital of Assyria . 2764<sup>b</sup>  
 Monoliths of . . . . . 2765<sup>a</sup>  
 Mounds of Assur . . . . . 2764<sup>b</sup>  
 Temple of Assur . . . . . 2765<sup>a</sup>  
 Tombs of kings . . . . . 2765<sup>b</sup>
- Sheriff . . . . . 2765<sup>b</sup>
- Sheshach . . . . . 2765<sup>b</sup> (Wolf)  
 cf Jeremiah . . . . . 1587<sup>b</sup> (Roberts)
- Sheshai . . . . . 2766<sup>a</sup>
- Sheshan . . . . . 2766<sup>a</sup>
- Sheshbazzar . . . . . 2766<sup>a</sup> (R. D. Wilson)  
 cf Sanabassar, Sanabassar (Apoc) . . . . . 2681<sup>a</sup> (Angus)
- Sheth . . . . .  
 cf Seth . . . . . 2743<sup>b</sup> (S. F. Hunter)
- Shethar . . . . . 2766<sup>a</sup>
- Shethar-bozenai, Shetharboznai . . . . . 2766<sup>b</sup> (Wolf)  
 cf Sathrabuzanes . . . . . 2696<sup>b</sup>
- Sheva . . . . . 2766<sup>b</sup>  
 cf Shavsha . . . . . 2751<sup>b</sup> (Wolf)
- Shew, Show . . . . . 2766<sup>b</sup> (Easton)
- Shewbread . . . . . 2767<sup>a</sup> (Caldecott)  
 Frankincense with . . . . . 2767<sup>b</sup>  
 On journeys . . . . . 2767<sup>a</sup>  
 Meaning of term . . . . . 2767<sup>a</sup>  
 Priestly regulations . . . . . 2767<sup>a</sup>  
 cf Shewbread, Table of . 2767<sup>b</sup> (Caldecott)  
 Significance . . . . . 2767<sup>a</sup>
- Shewbread, Table of . . . . . 2767<sup>b</sup> (Caldecott)  
 cf Shewbread . . . . . 2767<sup>a</sup> (Caldecott)  
 cf Tabernacle . . . . . 2891<sup>a</sup> (Caldecott; Orr)  
 cf Table . . . . . 2898<sup>a</sup> (Easton)  
 cf Temple . . . . . 2933<sup>b</sup> (Caldecott; Orr)
- Shibah . . . . . 2767<sup>b</sup>  
 cf Beer-sheba . . . . . 424<sup>b</sup> (Masterman)  
 cf Sheba (place) . . . . . 2753<sup>a</sup> (Masterman)
- Shibboleth . . . . . 2767<sup>b</sup>
- Shibmah (Sibmah)  
 cf Sebam . . . . . 2711<sup>a</sup> (Ewing)
- Shieron . . . . .  
 cf Shikkeron . . . . . 2768<sup>a</sup>
- Shield . . . . .  
 cf Armor, Arms . . . . . 252<sup>b</sup> (Nicol)
- Shiggaion . . . . . 2767<sup>b</sup>  
 cf Psalms, Book of . . . . . 2487<sup>a</sup> (Sampey)
- Shihon . . . . .  
 cf Shion . . . . . 2774<sup>a</sup>
- Shihor . . . . . 2768<sup>a</sup> (Kyle)  
 cf Gihon . . . . . 1228<sup>b</sup> (Masterman)  
 cf Nile . . . . . 2145<sup>a</sup> (Kyle)
- Shihor-libnath . . . . . 2768<sup>a</sup> (Ewing)
- Shikkeron . . . . . 2768<sup>a</sup>
- Shilhi . . . . . 2768<sup>b</sup>
- Shilhim . . . . . 2768<sup>b</sup>  
 cf Shaaraim . . . . . 2745<sup>a</sup> (Masterman)
- Shillem, Shillemites . . . . . 2768<sup>b</sup>  
 cf Shallum . . . . . 2747<sup>a</sup> (Umbach)
- Shiloah . . . . .  
 cf Jerusalem . . . . . 1601<sup>b</sup>; 1609<sup>b</sup> (Masterman)  
 cf Siloam . . . . . 2791<sup>a</sup> (Masterman)
- Shiloh (person) . . . . . 2768<sup>b</sup> (Orr)  
 cf Prophecy . . . . . 2459<sup>b</sup> (Orelli)
- Shiloh (place) . . . . . 2768<sup>b</sup> (Ewing)  
 Early references . . . . . 2769<sup>b</sup>  
 cf Jerusalem . . . . . 1609<sup>a</sup> (Masterman)  
 Sanctuary in Ephraim . 2769<sup>a</sup>  
 Site and ruins . . . . . 2769<sup>a</sup>  
 cf Tabernacle . . . . . 2891<sup>b</sup> (Caldecott; Orr)
- Shilonite . . . . . 2769<sup>b</sup>
- Shilshah . . . . . 2769<sup>b</sup>
- Shimea . . . . . 2769<sup>b</sup>  
 cf Shammah . . . . . 2749<sup>a</sup> (Wolf)  
 cf Shammua . . . . . 2749<sup>b</sup>
- Shimeah . . . . . 2769<sup>b</sup>

- Shimeam  
 of Shimeah . . . . . 2769<sup>b</sup>  
 Shimeath . . . . . 2769<sup>b</sup> (Wolf)  
 of Shomer . . . . . 2779<sup>b</sup>  
 Shimeathites . . . . . 2769<sup>b</sup> (Wolf)  
 Shimei . . . . . 2770<sup>a</sup> (Mack)  
 of Semei . . . . . 2717<sup>a</sup>  
 of Semeias . . . . . 2717<sup>a</sup>  
 of Semeis (Apoc) . . . . . 2717<sup>a</sup>  
 of Shammah . . . . . 2749<sup>a</sup> (Wolf)  
 of Shema (person) . . . . . 2759<sup>b</sup> (Wolf)  
 of Someis (Apoc) . . . . . 2826<sup>a</sup>  
 Shimeon . . . . . 2770<sup>b</sup>  
 Shimhi  
 of Shimei . . . . . 2770<sup>a</sup> (Mack)  
 Shimi, Shimites  
 of Shimei . . . . . 2770<sup>a</sup> (Mack)  
 Shimma  
 of Shammah . . . . . 2749<sup>a</sup> (Wolf)  
 Shimon . . . . . 2770<sup>b</sup>  
 Shimrath . . . . . 2770<sup>b</sup>  
 Shimri . . . . . 2770<sup>b</sup> (Umbach)  
 Shimrith . . . . . 2771<sup>a</sup>  
 of Shomer . . . . . 2779<sup>b</sup>  
 Shimron (person) . . . . . 2771<sup>a</sup>  
 Shimron (place) . . . . . 2771<sup>a</sup> (Ewing)  
 Shimron-meron . . . . . 2771<sup>a</sup> (Ewing)  
 Shimshai . . . . . 2771<sup>a</sup> (Wolf)  
 of Rehum . . . . . 2552<sup>b</sup> (Stearns)  
 of Samellius (Apoc) . . . . . 2674<sup>a</sup>  
 Shin, Sin . . . . . 2771<sup>a</sup>  
 of Alphabet . . . . . 103<sup>b</sup> (Richardson)  
 Shinab . . . . . 2771<sup>a</sup> (Wolf)  
 of Admah . . . . . 56<sup>b</sup> (Wright)  
 of Shemeber . . . . . 2760<sup>b</sup>  
 Shinar . . . . . 2771<sup>b</sup> (Pinches)  
 of Babel . . . . . 350<sup>a</sup> (Pinches)  
 of Babel, Tower of . . . . . 355<sup>b</sup> (Pinches)  
 of Calneh . . . . . 546<sup>a</sup> (Pinches)  
 Comparison with Semitic . . . . . 2772<sup>a</sup>  
 Condition and climate . . . . . 2773<sup>a</sup>  
 Districts of . . . . . 2772<sup>b</sup>  
 of Eden . . . . . 897<sup>b</sup> (Wright)  
 Form of word . . . . . 2771<sup>b</sup>  
 Form of writing . . . . . 2773<sup>b</sup>  
 of Jonah . . . . . 1727<sup>b</sup> (Sampey)  
 of Jonah, Book of . . . . . 1728<sup>a</sup> (Sampey)  
 Land of Babylonia . . . . . 2771<sup>b</sup>  
 Primitive tongue of . . . . . 2772<sup>a</sup>  
 Priority of Sumerians . . . . . 2772<sup>b</sup>  
 Sculptures . . . . . 2772<sup>a</sup>  
 Sumerian equivalents . . . . . 2771<sup>b</sup>  
 Syriac Sen'ar . . . . . 2772<sup>a</sup>  
 of Ur of the Chaldees . . . . . 3039<sup>a</sup> (Clay)  
 Shine . . . . . 2773<sup>b</sup> (Dosker)  
 Shion . . . . . 2774<sup>a</sup>  
 Shiphi . . . . . 2774<sup>a</sup>  
 Shiphmite  
 of Shepham . . . . . 2762<sup>a</sup>  
 of Siphmoth . . . . . 2806<sup>a</sup>  
 Shiphrah . . . . . 2774<sup>a</sup>  
 of Zipporah . . . . . 3152<sup>b</sup> (Kyle)
- Shiptan . . . . . 2774<sup>a</sup>  
 Shipmaster  
 of Phoenix . . . . . 2391<sup>a</sup> (Calder)  
 of Ships and Boats . . . . . 2774<sup>a</sup> (Nicol)  
 Shipmen  
 of Ships and Boats . . . . . 2774<sup>a</sup> (Nicol)  
 Ships and Boats . . . . . 2774<sup>a</sup> (Nicol)  
 In the Acts . . . . . 2776<sup>b</sup>  
 In Assyria and Babylonia . . . . . 2775<sup>b</sup>  
 In Corinthians and other Books . . . . . 2777<sup>b</sup>  
 In Egypt . . . . . 2775<sup>b</sup>  
 Equipment of . . . . . 2777<sup>a</sup>  
 Figurative use . . . . . 2777<sup>b</sup>  
 of Gallant . . . . . 1167<sup>a</sup>  
 General references . . . . . 2776<sup>a</sup>  
 In the Gospels . . . . . 2776<sup>a</sup>  
 of Harbour . . . . . 1337<sup>b</sup>  
 Hebrews, among the . . . . . 2774<sup>b</sup>  
 Hebrews and the sea . . . . . 2774<sup>b</sup>  
 Measures in storm . . . . . 2777<sup>a</sup>  
 In NT . . . . . 2776<sup>a</sup>  
 In OT and Apoc . . . . . 2774<sup>b</sup>  
 Paul's voyages . . . . . 2776<sup>b</sup>  
 of Pharaoh-necoh . . . . . 2360<sup>a</sup> (Nicol)  
 In Phoenicia . . . . . 2775<sup>b</sup>  
 of Plank . . . . . 2407<sup>b</sup>  
 of Red Sea . . . . . 2539<sup>a</sup> (Wright)  
 of Rope . . . . . 2623<sup>b</sup> (Easton)  
 of Sign . . . . . 2789<sup>a</sup> (Stuart)  
 of Trade . . . . . 3003<sup>a</sup> (Easton)  
 of Traffic . . . . . 3004<sup>b</sup> (Raffety)  
 Words used for . . . . . 2774<sup>a</sup>  
 Shisha . . . . . 2777<sup>b</sup>  
 of Shavsha . . . . . 2751<sup>b</sup> (Wolf)  
 Shishak . . . . . 2777<sup>b</sup> (Nicol)  
 Inscription at Karnak . . . . . 2778<sup>a</sup>  
 Invasion of Palestine . . . . . 2778<sup>a</sup>  
 of Jerusalem . . . . . 1615<sup>a</sup> (Masterman)  
 of Lubim . . . . . 1934<sup>b</sup>  
 of Rehoboam . . . . . 2552<sup>a</sup> (Mosiman)  
 Relations with Jeroboam . . . . . 2777<sup>b</sup>  
 Rise to power . . . . . 2777<sup>b</sup>  
 Shitrai . . . . . 2778<sup>b</sup>  
 of Sharonite . . . . . 2751<sup>a</sup>  
 Shittah Tree . . . . . 2778<sup>b</sup> (Masterman)  
 of Shittim Wood . . . . . 508<sup>b</sup> (Masterman)  
 Shittim . . . . . 2778<sup>b</sup> (Ewing)  
 Shiza . . . . . 2778<sup>b</sup>  
 Shoa . . . . . 2778<sup>b</sup>  
 Shobab . . . . . 2779<sup>a</sup>  
 Shobach . . . . . 2779<sup>a</sup>  
 Shobai . . . . . 2779<sup>a</sup>  
 Shobal . . . . . 2779<sup>a</sup>  
 Shobek . . . . . 2779<sup>a</sup>  
 Shobi . . . . . 2779<sup>a</sup>  
 Shochoh . . . . . 2779<sup>a</sup>  
 of Socoh . . . . . 2821<sup>a</sup> (Masterman)  
 Shoe, Shoe-latchet . . . . . 2779<sup>a</sup> (Easton)  
 Shoham . . . . . 2779<sup>b</sup>

Shomer . . . . . 2779<sup>b</sup>  
 cf Shemer . . . . . 2760<sup>b</sup> (Wolf)  
 cf Shimeath . . . . . 2769<sup>b</sup> (Wolf)  
 cf Shimrith . . . . . 2771<sup>a</sup>  
 Shophach  
 cf Shobach . . . . . 2779<sup>a</sup>  
 Shophan  
 cf Atroth-shophan . . . . . 328<sup>a</sup>  
 Shore . . . . . 2779<sup>b</sup> (Day)  
 cf Coast . . . . . 672<sup>a</sup> (Day)  
 cf Haven . . . . . 1344<sup>b</sup> (Day)  
 cf Sand . . . . . 2688<sup>b</sup> (Day)  
 Shorten . . . . . 2780<sup>a</sup>  
 Shoshannim Eduth  
 cf Psalms, Book of . . . . . 2487<sup>a</sup> (Sampey)  
 cf Song . . . . . 2830<sup>b</sup> (Millar)  
 Shoulder . . . . . 2780<sup>a</sup> (Luering)  
 cf Sacrifice, NT . . . . . 2651<sup>a</sup> (Williams)  
 cf Sacrifice, OT . . . . . 2638<sup>a</sup> (Reeve)  
 Shoulder-blade . . . . . 2780<sup>b</sup>  
 Shoulder-piece . . . . . 2780<sup>b</sup> (Luering)  
 Shovel . . . . . 2780<sup>b</sup> (Patch)  
 Show  
 cf Shew . . . . . 2766<sup>b</sup> (Easton)  
 Showbread  
 cf Shewbread . . . . . 2767<sup>a</sup> (Caldecott)  
 Showbread, Table of  
 cf Shewbread, Table of 2767<sup>b</sup> (Caldecott)  
 Shower . . . . . 2781<sup>a</sup> (Day)  
 Shrine . . . . . 2781<sup>a</sup>  
 Shroud . . . . . 2781<sup>a</sup>  
 cf Burial . . . . . 529<sup>a</sup> (Eager)  
 Shrub . . . . . 2781<sup>a</sup>  
 cf Bush . . . . . 532<sup>a</sup> (Masterman)  
 Shua, Shuah . . . . . 2781<sup>a</sup>  
 cf Bath-shua . . . . . 416<sup>b</sup>  
 cf Bildad . . . . . 473<sup>b</sup> (Gnung)  
 cf Shuhah . . . . . 2781<sup>a</sup>  
 cf Shuhite . . . . . 2781<sup>b</sup>  
 Shual . . . . . 2781<sup>a</sup>  
 Shual, Land of . . . . . 2781<sup>a</sup> (Ewing)  
 Shubael . . . . . 2781<sup>a</sup>  
 cf Shebuel . . . . . 2754<sup>b</sup>  
 Shuhah . . . . . 2781<sup>a</sup>  
 cf Shua, Shuah . . . . . 2781<sup>a</sup>  
 Shuham . . . . . 2781<sup>b</sup>  
 Shuhite . . . . . 2781<sup>b</sup>  
 cf Bildad . . . . . 473<sup>b</sup> (Gnung)  
 cf Shua, Shuah . . . . . 2781<sup>a</sup>  
 Shulammit . . . . . 2781<sup>b</sup>  
 cf Shunammite . . . . . 2781<sup>b</sup> (Ewing)  
 Shumathites . . . . . 2781<sup>b</sup>  
 Shunammite . . . . . 2781<sup>b</sup> (Ewing)  
 Shunem . . . . . 2781<sup>b</sup> (Ewing)  
 Shuni, Shunites . . . . . 2782<sup>a</sup>  
 Shupham, Shuphamites  
 cf Shephupham . . . . . 2764<sup>a</sup>  
 Shuppim . . . . . 2782<sup>a</sup>  
 cf Muppim . . . . . 2094<sup>a</sup>  
 cf Shephupham . . . . . 2764<sup>a</sup>  
 Shur . . . . . 2782<sup>a</sup> (Conder)  
 cf Migdol . . . . . 2051<sup>a</sup> (Conder)

Shur—*continued*

cf Wanderings of Israel . . . . . 3064<sup>a</sup> (Conder)  
 Shuruppak . . . . . 365<sup>a</sup> (Clay)  
 Shushan . . . . . 2782<sup>a</sup> (Pinches)  
 Citadel, the . . . . . 2782<sup>b</sup>  
 Description of Assur-  
 bani-apli . . . . . 2782<sup>b</sup>  
 cf Elam, Elamites . . . . . 917<sup>a</sup> (Pinches)  
 Meaning of name . . . . . 2782<sup>a</sup>  
 Monuments discovered 2782<sup>b</sup>  
 Ruins of . . . . . 2782<sup>a</sup>  
 Shushanchites . . . . . 2783<sup>a</sup>  
 Shushan Eduth  
 cf Psalms, Book of . . . . . 2487<sup>a</sup> (Sampey)  
 cf Song . . . . . 2830<sup>b</sup> (Millar)  
 Shuthalhites  
 cf Shuthelah . . . . . 2783<sup>a</sup>  
 Shuthelah, Shuthelahites 2783<sup>a</sup>  
 cf Genealogy . . . . . 1183<sup>b</sup> (Crannell)  
 Shuttle  
 cf Weaving . . . . . 3077<sup>a</sup> (Patch)  
 Sia, Siaha . . . . . 2783<sup>a</sup>  
 cf Sua (Apoc) . . . . . 2868<sup>a</sup>  
 Sibbecai, Sibbechai . . . . . 2783<sup>a</sup>  
 Sibboleth  
 cf Shibboleth . . . . . 2767<sup>b</sup>  
 Sibmah  
 cf Sebam . . . . . 2711<sup>a</sup> (Ewing)  
 Sibram . . . . . 2783<sup>a</sup>  
 Sibylline Oracles . . . . . 178<sup>a</sup> (J. E. H. Thomson)  
 cf Apocalyptic Literature . . . . . 161<sup>b</sup> (J. E. H. Thomson)  
 cf Messiah . . . . . 2042<sup>a</sup> (Crichton)  
 Sicarii  
 cf Assassins . . . . . 288<sup>a</sup> (S. F. Hunter)  
 Siche . . . . . 2783<sup>a</sup>  
 cf Shechem . . . . . 2755<sup>a</sup> (Ewing)  
 Sick, Sickness . . . . . 2783<sup>a</sup> (Macalister)  
 Causes of . . . . . 2783<sup>b</sup>  
 cf Disease . . . . . 854<sup>a</sup> (Macalister)  
 Forms of . . . . . 2783<sup>b</sup>  
 Jesus and the . . . . . 2783<sup>b</sup>  
 Terms used . . . . . 2783<sup>a</sup>  
 Visiting the . . . . . 2783<sup>b</sup>  
 Sickle . . . . . 2784<sup>a</sup> (Patch)  
 cf Reaping . . . . . 2534<sup>a</sup> (Patch)  
 cf Wine . . . . . 3086<sup>a</sup> (Easton)  
 Sicyon . . . . . 2784<sup>a</sup> (S. F. Hunter)  
 Siddim, Vale of . . . . . 2784<sup>a</sup>; 809<sup>b</sup> (Wright)  
 cf Arabah . . . . . 211<sup>b</sup> (Wright)  
 cf Dead Sea . . . . . 801<sup>a</sup> (Wright)  
 Geological changes . . . . . 2784<sup>b</sup>  
 Location . . . . . 2784<sup>a</sup>  
 cf Slime, Slime Pits . . . . . 2817<sup>b</sup> (Day)  
 Traditions regarding . . . . . 2784<sup>b</sup>  
 cf Zeboim . . . . . 3134<sup>a</sup>  
 Side . . . . . 2785<sup>a</sup> (Banks)  
 cf Pamphylia . . . . . 2236<sup>b</sup> (Banks)  
 Sides . . . . . 2785<sup>a</sup>  
 Sidon (person) . . . . . 2785<sup>a</sup>

- Sidon (place).....2785<sup>a</sup> (Porter)  
 Disasters to.....2785<sup>b</sup>  
 Harbors of.....2785<sup>a</sup>  
 History of.....2785<sup>b</sup>  
 Kings of.....2785<sup>b</sup>  
 Location.....2785<sup>a</sup>  
 In NT.....2786<sup>a</sup>  
 of Phoenicia.....2386<sup>a</sup> (Porter)  
 of Tyre.....3031<sup>a</sup> (Porter)  
 of Zarephath.....3132<sup>b</sup> (Ewing)  
 Sidonians.....2786<sup>a</sup>  
 Siege.....2786<sup>a</sup> (Nicol)  
 Assault, the.....2787<sup>b</sup>  
 Battering rams.....2787<sup>a</sup>  
 Defense against.....2787<sup>b</sup>  
 In early Hebrew history.....2786<sup>a</sup>  
 Figurative references.....2789<sup>a</sup>  
 In Hebrew monarchy.....2786<sup>b</sup>  
 Horrors of.....2788<sup>b</sup>  
 Laws regarding.....2786<sup>b</sup>  
 Mounds and approaches.....2787<sup>a</sup>  
 In NT.....2789<sup>a</sup>  
 Operations of.....2786<sup>b</sup>  
 In the prophets.....2786<sup>b</sup>  
 Raising the siege.....2788<sup>a</sup>  
 of Slave, Slavery.....2815<sup>b</sup> (Raffety)  
 Sieve, Sift  
 of Agriculture.....75<sup>b</sup> (Patch)  
 of Threshing.....2975<sup>b</sup> (Patch)  
 Siglos.....2789<sup>a</sup>  
 of Darcic.....788<sup>a</sup>  
 Sign.....2789<sup>a</sup> (Stuart)  
 of Dioscuri.....851<sup>a</sup> (Maunder)  
 of Immanuel.....1457<sup>b</sup> (A. W. Evans)  
 of Miracle.....2062<sup>b</sup> (Wace)  
 of Ships and Boats.....2777<sup>a</sup> (Nicol)  
 of Token.....2994<sup>a</sup> (Easton)  
 Signet  
 of Ring.....2594<sup>a</sup> (Crannell)  
 of Seal.....2708<sup>b</sup> (Edwards)  
 Signs of the Heavens  
 of Astronomy.....300<sup>b</sup> (Maunder)  
 Signs, Numerical  
 of Number.....2157<sup>a</sup> (Smith)  
 Sihon.....2790<sup>a</sup>  
 Sihor  
 of Shihor.....2768<sup>a</sup> (Kyle)  
 Sihor-libnath  
 of Shihor-libnath.....2768<sup>a</sup> (Ewing)  
 Silas.....2790<sup>a</sup> (Kerr)  
 Companion of Barnabas.....2790<sup>a</sup>  
 Journeys with Paul.....2790<sup>a</sup>  
 Movements of.....2790<sup>a</sup>  
 NT references to.....2790<sup>b</sup>  
 Silence.....2790<sup>b</sup>  
 Silk, Silkworm.....2790<sup>b</sup> (Day)  
 of Linen.....1894<sup>a</sup> (E. D. Isaacs)  
 of Weaving.....3077<sup>a</sup> (Patch)  
 Silla.....2791<sup>a</sup>  
 Siloam, Siloah, Shelah,  
 Shiloah.....2791<sup>a</sup> (Masterman)  
 Aqueduct.....2791<sup>b</sup>  
 of Gezer.....1224<sup>a</sup> (Masterman)  
 of Gihon.....1228<sup>b</sup> (Masterman)  
 Inscription.....2792<sup>b</sup>  
 of Jerusalem.....1606<sup>b</sup> (Masterman)  
 of Jerusalem Springs.....1597<sup>b</sup> (Masterman)  
 of Kidron, The Brook.....1798<sup>a</sup> (Masterman)  
 of King's Garden.....1808<sup>a</sup> (Masterman)  
 Modern Silwan.....2791<sup>b</sup>  
 Pool of.....2792<sup>a</sup>  
 Second pool.....2792<sup>b</sup>  
 of Sent.....2721<sup>a</sup> (W. L. Walker)  
 of Shelah.....2758<sup>b</sup>  
 Siloam Inscription  
 of Jerusalem.....1602<sup>a</sup> (Masterman)  
 Siloam, Tower in  
 of Jerusalem.....1602<sup>a</sup> (Masterman)  
 of Siloam.....2791<sup>a</sup> (Masterman)  
 Silvanus.....2792<sup>b</sup>  
 of Silas.....2790<sup>a</sup> (Kerr)  
 Silver.....2792<sup>b</sup> (Patch)  
 Silverling.....2793<sup>a</sup>  
 of Piece of Silver.....2395<sup>a</sup> (Porter)  
 Silversmith.....2793<sup>a</sup>  
 Simalcuc  
 of Imalcuc.....1456<sup>a</sup> (Hutchison)  
 Simeon (general).....2794<sup>a</sup> (S. F. Hunter)  
 Simeon (Niger).....2794<sup>b</sup>  
 of Symeon.....2877<sup>b</sup>  
 Simeon (patriarch and tribe).....2793<sup>a</sup> (Masterman)  
 Absorbed in Judah.....2793<sup>b</sup>  
 Fancied inscriptional references.....2794<sup>a</sup>  
 of Gedor.....1182<sup>a</sup> (Ewing)  
 of Leah.....1861<sup>b</sup> (Baur)  
 Meunim.....2793<sup>a</sup>  
 Mixed character of tribe.....2793<sup>b</sup>  
 Mt. Seir.....2794<sup>a</sup>  
 OT references.....2793<sup>b</sup>  
 Son of Jacob.....2793<sup>a</sup>  
 Territory of.....2794<sup>a</sup>  
 Simeonites  
 of Simeon (patriarch and tribe).....2793<sup>a</sup> (Masterman)  
 Similitude.....2794<sup>b</sup>  
 Simon (Apoc).....2794<sup>b</sup> (Angus)  
 of Maccabaens.....1946<sup>a</sup> (Hutchison)  
 of Thassi.....2965<sup>a</sup>  
 Simon the Canaanite, or Cananaean, or Zealot.....2797<sup>b</sup> (Kerr)  
 of James, Son of Alphaeus.....1561<sup>a</sup> (Kerr)  
 of Nathanael.....2121<sup>a</sup> (Kerr)  
 of Thaddaeus.....2964<sup>a</sup> (Kerr)  
 of Zealot, Zealots.....3133<sup>b</sup> (Heidel)  
 Simon (general).....2795<sup>a</sup> (S. F. Hunter)  
 of Brethren of the Lord 518<sup>b</sup> (Jacobs)  
 of Cyrenian.....773<sup>b</sup>

Simon (general)—*continued*

- cf Judas Iscariot. . . . . 1765<sup>b</sup> (Kerr)
- cf Nathanael. . . . . 2121<sup>a</sup> (Kerr)
- cf Peter (Simon). . . . . 2348<sup>b</sup> (Gray)
- cf Simeon (general). . . . . 2794<sup>a</sup> (S. F. Hunter)
- Simon the Maccabee. . . . . 285<sup>a</sup> (Dosker)
- cf Maccabaeus. . . . . 1946<sup>a</sup> (Hutchison)
- Simon Magus. . . . . 2795<sup>b</sup> (Rutherford)
- Contact with the apostles. . . . . 2795<sup>b</sup>
- Death of. . . . . 2797<sup>a</sup>
- Early Christian traditions. . . . . 2796<sup>a</sup>
- Followers of. . . . . 2797<sup>a</sup>
- cf Gnosticism. . . . . 1240<sup>a</sup> (Rutherford)
- cf Literature, Subapost. . . . . 1896<sup>b</sup> (Cowan)
- Magicians in NT. . . . . 2796<sup>a</sup>
- Mentioned as sorcerer. . . . . 2795<sup>b</sup>
- cf Peter, First Epistle of. . . . . 2351<sup>b</sup> (Moorehead)
- cf Peter, Second Epistle of. . . . . 2355<sup>a</sup> (Moorehead)
- cf Philip, the Evangelist. . . . . 2368<sup>b</sup> (S. F. Hunter)
- Sources of the stories. . . . . 2796<sup>b</sup>
- Story of Simon and Helena. . . . . 2796<sup>b</sup>
- Simon Peter. . . . . 2348<sup>b</sup> (Gray)
- Simon, the Tanner
  - cf Tanner. . . . . 2908<sup>b</sup> (Patch)
- Simple. . . . . 2798<sup>a</sup> (McPheeters)
- Simplicity. . . . . 2798<sup>a</sup> (W. L. Walker)
- Simri
  - cf Shimri. . . . . 2770<sup>b</sup> (Umbach)
- Sin. . . . . 2798<sup>b</sup> (McConnell)
  - cf Adam in the OT. . . . . 49<sup>b</sup> (Genung)
  - As disobedience. . . . . 2798<sup>b</sup>
  - Environment. . . . . 2800<sup>b</sup>
  - cf Ethics. . . . . 1013<sup>a</sup> (Alexander)
  - cf Ethics of Jesus. . . . . 1026<sup>a</sup> (Stalker)
  - Fall, story of. . . . . 2798<sup>b</sup>
  - Forgiveness. . . . . 2801<sup>b</sup>
  - Freedom of man. . . . . 2799<sup>a</sup>
  - cf Guilt. . . . . 1309<sup>a</sup> (Rall)
  - Hereditiy. . . . . 2800<sup>b</sup>
    - cf Hereditiy. . . . . 1376<sup>a</sup> (Easton)
  - Inner law, the. . . . . 2799<sup>b</sup>
    - cf Johannine Theology. . . . . 1701<sup>b</sup> (Law)
  - Life in Christ. . . . . 2801<sup>a</sup>
  - cf Paul, the Apostle. . . . . 2264<sup>b</sup> (A. T. Robertson)
  - cf Pauline Theology. . . . . 2289<sup>a</sup> (Easton)
  - Positive force, a. . . . . 2800<sup>a</sup>
  - Prophetic teachings. . . . . 2799<sup>b</sup>
  - Redemption. . . . . 2801<sup>a</sup>
    - cf Redemption. . . . . 2541<sup>a</sup> (McConnell)
  - Repentance. . . . . 2801<sup>b</sup>
  - cf Sanctification. . . . . 2683<sup>b</sup> (Rall)
  - cf Sinner. . . . . 2806<sup>a</sup> (M. O. Evans)
  - Teachings of Paul. . . . . 2799<sup>b</sup>
  - cf Tradition. . . . . 3004<sup>a</sup> (Williams)

Sin—*continued*

- Transgression against light. . . . . 2799<sup>a</sup>
- cf Truth. . . . . 3025<sup>a</sup> (Carver)
- cf Wickedness. . . . . 3083<sup>b</sup> (Dungan)
- Sin (deity). . . . . 371<sup>a</sup> (Rogers)
- Sin (place). . . . . 2802<sup>a</sup> (Kyle)
- Sin against the Holy Ghost (Spirit)
  - cf Blasphemy. . . . . 485<sup>b</sup> (Rees)
- Sin, Man of. . . . . 1975<sup>b</sup> (Orr)
- Sin Money
  - cf Sacrifice in the OT. . . . . 2638<sup>a</sup> (Reeve)
- Sin Offering
  - cf Sacrifice in the NT. . . . . 2651<sup>a</sup> (Williams)
  - cf Sacrifice in the OT. . . . . 2638<sup>a</sup> (Reeve)
- Sin, Shin. . . . . 2771<sup>a</sup>
- Sin, Wilderness of
  - cf Wanderings of Israel. . . . . 3064<sup>a</sup> (Conder)
- Sina. . . . . 2802<sup>a</sup>
  - cf Sinai. . . . . 2802<sup>b</sup> (Conder)
- Sinai. . . . . 2802<sup>b</sup> (Conder)
  - Jebel Musa. . . . . 2803<sup>a</sup>
  - Location of. . . . . 1516<sup>a</sup> (Orelli)
  - Modern views. . . . . 2804<sup>a</sup>
  - cf Moses. . . . . 2087<sup>a</sup> (Kyle)
  - Name. . . . . 2802<sup>b</sup>
  - OT references. . . . . 2802<sup>b</sup>
  - Patristic views. . . . . 2804<sup>a</sup>
  - Peaks of Jebel Musa. . . . . 2803<sup>b</sup>
  - Traditional site. . . . . 2802<sup>b</sup>
    - cf Wanderings of Israel. . . . . 3064<sup>a</sup> (Conder)
- Sincere, Sincerity. . . . . 2804<sup>b</sup> (W. L. Walker)
- Sinew. . . . . 2804<sup>b</sup> (Luering)
  - cf Hip. . . . . 1394<sup>b</sup>
- Singers, Singing. . . . . 2804<sup>b</sup> (Millar)
  - cf Music. . . . . 2094<sup>b</sup> (Millar)
  - cf Praise. . . . . 2429<sup>a</sup> (Lambert)
  - cf Priests and Levites. . . . . 2446<sup>b</sup> (Wiener)
  - cf Song. . . . . 2830<sup>b</sup> (Millar)
  - cf Temple. . . . . 2930<sup>a</sup> (Caldecott; Orr)
- Single Eye. . . . . 2805<sup>a</sup> (Easton)
- Singular. . . . . 2805<sup>a</sup>
- Simin, Land of. . . . . 2805<sup>b</sup> (Ewing)
- Sinites. . . . . 2805<sup>b</sup>
- Sinlessness. . . . . 2805<sup>b</sup> (Dunelm)
  - Christ sinless. . . . . 2805<sup>b</sup>
    - cf Flesh. . . . . 1118<sup>b</sup> (Luering)
    - cf Jesus Christ. . . . . 1630<sup>b</sup> (Orr)
    - Saints not sinless. . . . . 2806<sup>a</sup>
      - cf Spirit. . . . . 2841<sup>b</sup> (Marais)
- Sinner. . . . . 2806<sup>a</sup> (M. O. Evans)
  - cf Sin. . . . . 2798<sup>b</sup> (McConnell)
- Sion. . . . . 2806<sup>a</sup>
  - cf Hermon. . . . . 1378<sup>a</sup> (Ewing)
  - cf Zion. . . . . 3150<sup>b</sup> (Masterman)
- Siphmoth. . . . . 2806<sup>a</sup>
- Sippai
  - cf Saph. . . . . 2690<sup>b</sup>
- Sir. . . . . 2806<sup>a</sup>

- Sirach, The Alphabet of . 2812<sup>a</sup> (T. W. Davies)
- Sirach, Book of, or The  
Wisdom of Jesus, the  
Son of Sirach . . . . . 2806<sup>b</sup> (T. W. Davies)
- Author . . . . . 2809<sup>b</sup>
- Canonicity . . . . . 2807<sup>a</sup>
- Composed in Hebrew . 2811<sup>a</sup>
- Contents . . . . . 2807<sup>a</sup>
- Date . . . . . 2810<sup>a</sup>
- Eschatology of . . . . . 2808<sup>b</sup>
- Literary form . . . . . 2809<sup>a</sup>
- Maxims . . . . . 2809<sup>a</sup>
- Moral teachings of . . . 2808<sup>b</sup>
- Name . . . . . 2806<sup>b</sup>
- Original languages . . . 2811<sup>a</sup>
- Teachings of . . . . . 2807<sup>b</sup>
- Teachings on manners . 2809<sup>a</sup>
- Unity and integrity . . . 2809<sup>b</sup>
- Versions . . . . . 2811<sup>b</sup>
- View of religion . . . . . 2807<sup>b</sup>
- of Wisdom . . . . . 3089<sup>a</sup> (Easton)
- of Wisdom of Solomon . 3092<sup>a</sup> (T. W. Davies)
- Sirah, Well of . . . . . 2812<sup>b</sup>
- Sirion . . . . . 2812<sup>b</sup>
- of Hermon . . . . . 1378<sup>a</sup> (Ewing)
- Sisamai  
of Sismai . . . . . 2813<sup>a</sup>
- Sisera . . . . . 2812<sup>b</sup> (Schenk)
- of Deborah . . . . . 813<sup>b</sup> (Margolis)
- of Jael . . . . . 1557<sup>b</sup> (Schenk)
- of Palestine . . . . . 2213<sup>b</sup> (Conder)
- of Serar (Apoc) . . . . . 2732<sup>b</sup>
- Sisennes . . . . . 2813<sup>a</sup>
- of Tattenai . . . . . 2917<sup>b</sup> (Umbach)
- Sismai . . . . . 2813<sup>a</sup>
- Sister . . . . . 2813<sup>a</sup> (Pollard)
- of Relationships, Family . . . . . 2554<sup>a</sup> (N. and E. D. Isaacs)
- Sister's Son . . . . . 2813<sup>a</sup>
- of Relationships, Family . . . . . 2554<sup>a</sup> (N. and E. D. Isaacs)
- Sith . . . . . 2813<sup>a</sup>
- Sithri . . . . . 2813<sup>a</sup>
- Sitnah . . . . . 2813<sup>a</sup>
- of Rehoboth . . . . . 2552<sup>a</sup> (Masterman)
- Sitting . . . . . 2813<sup>b</sup> (M. O. Evans)
- Sivan . . . . . 2813<sup>b</sup>
- of Calendar . . . . . 541<sup>b</sup> (Porter)
- Sixty . . . . . 2813<sup>b</sup>
- of Number . . . . . 2157<sup>a</sup> (Smith)
- Skill, Skilful . . . . . 2813<sup>b</sup> (N. Isaacs)
- Skin . . . . . 2813<sup>b</sup> (Lueling)
- For clothing and shoes . 2814<sup>a</sup>
- Figurative use . . . . . 2814<sup>a</sup>
- Literal use . . . . . 2814<sup>a</sup>
- of Sealskin . . . . . 2709<sup>b</sup>
- Skirt . . . . . 2814<sup>b</sup>
- of Dress . . . . . 875<sup>b</sup> (Eager)
- of Train (noun) . . . . . 3005<sup>a</sup>
- Skull . . . . . 2814<sup>b</sup>
- of Golgotha . . . . . 1275<sup>a</sup> (Masterman)
- Sky . . . . . 2814<sup>b</sup> (Day)
- of Heavens . . . . . 1352<sup>b</sup> (Orr)
- Slander . . . . . 2814<sup>b</sup> (Edwards)
- of Crimes . . . . . 745<sup>b</sup> (Hirsch)
- of Tale . . . . . 2904<sup>a</sup> (T. Lewis)
- Slaughter of the Innocents . . . . . 1471<sup>a</sup> (Sweet)
- Slaughter, Valley of . . . 2815<sup>a</sup>
- of Hinnom, Valley of . . 1393<sup>b</sup> (Masterman)
- of Jerusalem . . . . . 1599<sup>a</sup> (Masterman)
- Slave, Slavery . . . . . 2815<sup>a</sup> (Raffety)
- Acquisition . . . . . 2815<sup>a</sup>
- of Egypt . . . . . 906<sup>a</sup> (Petrie)
- Freedom of slaves . . . . 2815<sup>b</sup>
- of Israel, History of the  
People . . . . . 1511<sup>b</sup> (Orelli)
- of Labor . . . . . 1819<sup>b</sup> (Orr)
- of Manservant . . . . . 1983<sup>b</sup>
- NT conception . . . . . 2817<sup>a</sup>
- of Pharaoh . . . . . 2359<sup>a</sup> (Kyle)
- of Relationships, Family . . . . . 2556<sup>b</sup> (N. and E. D. Isaacs)
- Rights of masters . . . . . 2816<sup>b</sup>
- Rights of slaves . . . . . 2816<sup>b</sup>
- of Servant . . . . . 2738<sup>b</sup> (McGlothlin)
- of Siege . . . . . 2786<sup>a</sup> (Nicol)
- Slavonic Versions . . . . 3048<sup>a</sup> (Easton)
- Slaying . . . . . 2817<sup>a</sup>
- of Punishments . . . . . 2504<sup>b</sup> (Hirsch)
- Sleep . . . . . 2817<sup>a</sup>
- of Dream, Dreamer . . . 874<sup>a</sup> (Clippinger)
- Sleep, Deep . . . . . 2817<sup>b</sup> (Easton)
- Sleeves  
of Dress . . . . . 875<sup>b</sup> (Eager)
- Sleight . . . . . 2817<sup>b</sup>
- Slime, Slime Pits . . . . . 2817<sup>b</sup> (Day)
- of Cities of the Plain . . 660<sup>a</sup> (Wright)
- of Pitch . . . . . 2401<sup>b</sup> (Easton)
- of Siddim, Vale of . . . . 2784<sup>a</sup> (Wright)
- Sling  
of Armor, Arms . . . . . 251<sup>a</sup> (Nicol)
- Slip . . . . . 2817<sup>b</sup>
- Slopes  
of Ashdoth-pisgah . . . . 268<sup>a</sup>
- Slow . . . . . 2818<sup>a</sup>
- Sluggard . . . . . 2818<sup>a</sup>
- Sluice . . . . . 2818<sup>a</sup>
- Smell . . . . . 2818<sup>a</sup> (Lueling)
- Smith  
of Crafts . . . . . 734<sup>a</sup> (Patch)
- of Tools . . . . . 2998<sup>b</sup> (Easton)
- of Tubal-cain . . . . . 3027<sup>b</sup> (Wolf)
- Smiting by the Sun  
of Sun, Smiting by . . . . 2870<sup>b</sup> (Macalister)
- Smoke . . . . . 2818<sup>b</sup>
- Smyrna . . . . . 2818<sup>b</sup> (Banks)
- Ancient . . . . . 2818<sup>b</sup>
- of Angels of the Seven  
Churches . . . . . 135<sup>b</sup> (Banks)

- Smyrna—*continued*  
 History . . . . . 2818<sup>b</sup>  
 Modern . . . . . 2819<sup>a</sup>  
 Snail . . . . . 2819<sup>a</sup> (Day)  
 of Lizard . . . . . 1906<sup>a</sup> (Day)  
 of Sand-lizard . . . . . 2688<sup>b</sup>  
 Snare . . . . . 2819<sup>a</sup> (Stratton-Porter)  
 of Fowler . . . . . 1143<sup>b</sup> (Stratton-Porter)  
 of Gin . . . . . 1231<sup>b</sup> (Stratton-Porter)  
 of Trap . . . . . 3007<sup>a</sup> (Stratton-Porter)  
 Sneeze . . . . . 2819<sup>b</sup>  
 of Neesing . . . . . 2130<sup>a</sup> (Easton)  
 Snow . . . . . 2819<sup>b</sup> (Joy)  
 Snuffers, Snuffdishes . . . . . 2820<sup>a</sup> (Caldecott)  
 of Tongs . . . . . 2994<sup>a</sup>  
 So . . . . . 2820<sup>a</sup> (Nicol)  
 Soap . . . . . 2820<sup>b</sup> (Patch)  
 of Wash . . . . . 3072<sup>b</sup> (Easton)  
 Sober, Sobriety, Soberness . . . . . 2820<sup>b</sup> (Jacobs)  
 of Temperance, Temperate . . . . . 2929<sup>b</sup> (Jacobs)  
 Socho . . . . . 2820<sup>b</sup>  
 of Socoh . . . . . 2821<sup>a</sup> (Masterman)  
 Socket . . . . . 2821<sup>a</sup> (Caldecott)  
 of Tenon . . . . . 2947<sup>a</sup> (Caldecott)  
 Socoh, Soco, Shochoh, Shoco, Shocho . . . . . 2821<sup>a</sup> (Masterman)  
 Socrates . . . . . 1017<sup>a</sup> (Alexander)  
 Sod, Sodden  
 of Seethe . . . . . 2713<sup>a</sup>  
 Soda  
 of Nitre . . . . . 2153<sup>a</sup> (Patch)  
 Sodering . . . . . 2821<sup>a</sup>  
 Sodi . . . . . 2821<sup>a</sup>  
 Sodom . . . . . 2821<sup>b</sup> (Wright)  
 of Arabah . . . . . 211<sup>b</sup> (Wright)  
 of Cities of the Plain . . . . . 660<sup>a</sup> (Wright)  
 of Dead Sea . . . . . 801<sup>a</sup> (Wright)  
 And Gomorrah  
 Geological theory of  
 destruction of . . . . . 230<sup>a</sup> (Kyle)  
 of Lot . . . . . 1930<sup>b</sup> (Boyd)  
 of Siddim, Vale of . . . . . 2784<sup>a</sup> (Wright)  
 Sodom, Vine of . . . . . 2821<sup>b</sup> (Masterman)  
 of Vine . . . . . 3050<sup>b</sup> (Masterman)  
 Sodomite . . . . . 2821<sup>b</sup> (Ewing)  
 of Dead Sea . . . . . 801<sup>a</sup> (Wright)  
 Sodomitish Sea  
 of Dead Sea . . . . . 801<sup>a</sup> (Wright)  
 Sodomy  
 of Crimes . . . . . 745<sup>b</sup> (Hirsch)  
 of Punishments . . . . . 2504<sup>b</sup> (Hirsch)  
 of Sodom . . . . . 2821<sup>b</sup> (Wright)  
 Sojourner . . . . . 2821<sup>b</sup>  
 of Stranger and Sojourner (in NT and OT) . . . . . 2865<sup>a</sup> (Wiener); 2866<sup>a</sup> (Easton)  
 Soldering  
 of Sodering . . . . . 2821<sup>a</sup>  
 Soldier  
 of Armor, Arms . . . . . 251<sup>a</sup> (Nicol)
- Solemn Assembly (Meeting)  
 of Congregation . . . . . 700<sup>b</sup> (Wiener)  
 of Feasts and Fasts . . . . . 1103<sup>a</sup> (E. D. Isaacs)  
 of Solemn, Solemnity . . . . . 2821<sup>b</sup> (Easton)  
 Solemn, Solemnity . . . . . 2821<sup>b</sup> (Easton)  
 of Feasts and Fasts . . . . . 1103<sup>a</sup> (E. D. Isaacs)  
 of Sound . . . . . 2838<sup>a</sup> (Easton)  
 Solomon . . . . . 2822<sup>a</sup> (Weir); 256<sup>a</sup> (Nicol)  
 Alliances of . . . . . 2823<sup>b</sup>  
 Building operations . . . . . 2824<sup>a</sup>  
 Buildings of . . . . . 1614<sup>b</sup> (Masterman)  
 Career of . . . . . 2824<sup>a</sup>  
 Character of . . . . . 2824<sup>a</sup>  
 And Chemosh worship 601<sup>b</sup> (Nicol)  
 Domestic troubles . . . . . 2823<sup>b</sup>  
 Early career . . . . . 2822<sup>b</sup>  
 of Jerusalem . . . . . 1595<sup>b</sup> (Masterman)  
 of Millo . . . . . 2055<sup>a</sup> (Masterman)  
 Name and meaning . . . . . 2822<sup>a</sup>  
 of Nethinim . . . . . 2139<sup>b</sup> (Lees)  
 Odes of . . . . . 174<sup>b</sup> (J. E. H. Thomson)  
 Officers of . . . . . 2825<sup>a</sup>  
 Policy of . . . . . 2823<sup>a</sup>  
 Reign of . . . . . 2823<sup>a</sup>  
 of Ships and Boats . . . . . 2774<sup>a</sup> (Nicol)  
 Sources . . . . . 2822<sup>b</sup>  
 of Temple . . . . . 2930<sup>a</sup> (Caldecott; Orr)  
 Temple and palace of . . . . . 234<sup>b</sup> (A. C. Dickie)  
 of Text of the OT . . . . . 2957<sup>b</sup> (Weir)  
 of Trade . . . . . 3003<sup>a</sup> (Easton)  
 Trade and commerce . . . . . 2824<sup>b</sup>  
 Vision of . . . . . 2823<sup>a</sup>  
 Wisdom and learning of . . . . . 2824<sup>b</sup>  
 Wives of . . . . . 2825<sup>a</sup>  
 Solomon, Odes of  
 of Apocalyptic Literature . . . . . 161<sup>b</sup> (J. E. H. Thomson)  
 of Johannine Theology 1696<sup>b</sup> (Law)  
 Solomon, Pools of . . . . . 2419<sup>b</sup> (Day)  
 Solomon, Psalms (Psalter)  
 of . . . . . 161<sup>b</sup> (J. E. H. Thomson)  
 Solomon, Song of  
 of Song of Songs . . . . . 2831<sup>a</sup> (Sampey)  
 Solomon, Wisdom of . . . . . 3092<sup>a</sup> (T. W. Davies)  
 Solomon's Porch . . . . . 2421<sup>b</sup> (Caldecott)  
 Solomon's Servants . . . . . 2825<sup>b</sup> (Mack)  
 Levites or not? . . . . . 2825<sup>b</sup>  
 of Nethinim . . . . . 2139<sup>b</sup> (Lees)  
 Number and duties . . . . . 2825<sup>b</sup>  
 Temple servants . . . . . 2825<sup>b</sup>  
 Solyma  
 of Jerusalem . . . . . 1596<sup>b</sup> (Masterman)  
 Someis (Apoc) . . . . . 2826<sup>a</sup>  
 of Shimei . . . . . 2770<sup>a</sup> (Mack)  
 Sometime . . . . . 2826<sup>a</sup>  
 Son, Sons . . . . . 2826<sup>a</sup> (Betteridge)  
 of Bar (prefix) . . . . . 401<sup>b</sup>  
 of Ben (prefix) . . . . . 433<sup>b</sup> (Breslich)  
 of Heredity . . . . . 1376<sup>a</sup> (Easton)  
 of Relationships, Family . . . . . 2554<sup>a</sup> (N. and E. D. Isaacs)

- Son of God, The. . . . . 2826<sup>b</sup> (Stalker)  
 Apostolic doctrine. . . . . 2828<sup>a</sup>  
 Applied to Christ. . . . . 2827<sup>a</sup>  
 In Fourth Gospel. . . . . 2828<sup>b</sup>  
 Messianic meaning. . . . . 2827<sup>a</sup>  
 In OT. . . . . 2826<sup>b</sup>  
 of Only Begotten. . . . . 2196<sup>a</sup> (Rees)  
 Particular texts. . . . . 2827<sup>b</sup>  
 Use by Jesus. . . . . 2827<sup>b</sup>  
 Use of title. . . . . 2826<sup>b</sup>
- Son-in-Law  
 cf Relationships, Family. . . . . 2554<sup>a</sup> (N. and E. D. Isaacs)
- Son of Man, The. . . . . 2828<sup>b</sup> (Stalker)  
 Aramaic meaning. . . . . 2830<sup>b</sup>  
 In Daniel. . . . . 2829<sup>b</sup>  
 Extra-canonical literature. . . . . 2830<sup>a</sup>  
 of Jesus Christ. . . . . 1637<sup>a</sup> (Orr)  
 Jesus' Messianic consciousness. . . . . 2830<sup>a</sup>  
 of Messiah. . . . . 2043<sup>a</sup> (Crichton)  
 Messianic idea. . . . . 2829<sup>b</sup>  
 Source of title. . . . . 2829<sup>a</sup>  
 Usage in OT. . . . . 2829<sup>a</sup>  
 Use and meaning in  
 NT. . . . . 2829<sup>a</sup>  
 Why Jesus used title. . . . . 2830<sup>a</sup>  
 of Zoroastrianism. . . . . 3157<sup>a</sup> (Easton)
- Song. . . . . 2830<sup>b</sup> (Millar)  
 of Hind of the Morning. . . . . 1393<sup>a</sup> (M. O. Evans)  
 of Hymn. . . . . 1445<sup>a</sup> (Millar)  
 cf Jonath Elem Rehookim. . . . . 1730<sup>a</sup>  
 of Singers, Singing. . . . . 2804<sup>b</sup> (Millar)  
 of Song of Songs. . . . . 2831<sup>a</sup> (Sampey)  
 of Spiritual Songs. . . . . 2845<sup>a</sup> (Pratt)
- Song of Songs. . . . . 2831<sup>a</sup> (Sampey)  
 Allegorical interpretation. . . . . 2832<sup>a</sup>  
 Authorship and date. . . . . 2831<sup>b</sup>  
 Canonicity. . . . . 2831<sup>a</sup>  
 Ewald's view. . . . . 2833<sup>a</sup>  
 Hints and suggestions. . . . . 2833<sup>b</sup>  
 History of interpretation. . . . . 2831<sup>b</sup>  
 Literal interpretation. . . . . 2832<sup>b</sup>  
 of Palestine. . . . . 2218<sup>b</sup> (Conder)  
 of Song. . . . . 2830<sup>b</sup> (Millar)  
 Text. . . . . 2831<sup>b</sup>  
 Typical interpretation. . . . . 2832<sup>b</sup>  
 Wedding songs. . . . . 2833<sup>a</sup>
- Song of the Three Children  
 . . . . . 2834<sup>a</sup> (T. W. Davies)  
 Author and date. . . . . 2834<sup>b</sup>  
 of Bel and the Dragon. . . . . 428<sup>a</sup> (T. W. Davies)  
 Canonicity and contents. . . . . 2834<sup>a</sup>  
 Name. . . . . 2834<sup>a</sup>  
 Original language. . . . . 2835<sup>a</sup>
- Song of the Three Children—*continued*  
 cf Shadrach. . . . . 2746<sup>a</sup> (R. D. Wilson)  
 of Son, Sons. . . . . 2826<sup>a</sup> (Bettridge)
- Songs of Degrees. . . . . 819<sup>b</sup> (Sampey)  
 cf Dial of Ahaz. . . . . 842<sup>b</sup> (Maunder)
- Sons of God (NT). . . . . 2835<sup>b</sup> (W. Evans)  
 Doctrine of. . . . . 2835<sup>b</sup>  
 Terms. . . . . 2835<sup>b</sup>
- Sons of God (OT). . . . . 2835<sup>a</sup> (Crichton)  
 Angels. . . . . 2835<sup>b</sup>  
 cf Antediluvians. . . . . 143<sup>a</sup> (Wright)  
 cf Children of God. . . . . 608<sup>a</sup> (Rees)  
 In Genesis 6 2-4. . . . . 2835<sup>a</sup>  
 cf Giants. . . . . 1224<sup>b</sup> (Orr)  
 cf Gods. . . . . 1270<sup>b</sup> (Reeve)  
 Job and Psalms. . . . . 2835<sup>a</sup>  
 cf Rephaim. . . . . 2835<sup>a</sup>; 2559<sup>b</sup> (Porter)  
 Term. . . . . 2835<sup>a</sup>
- Sons of Korah. . . . . 1817<sup>b</sup> (Beecher)
- Sons of Solomon's Servants  
 cf Priests and Levites. . . . . 2446<sup>b</sup> (Wiener)
- Soothsayers  
 cf Astrology. . . . . 295<sup>b</sup> (Maunder)  
 cf Divination. . . . . 860<sup>a</sup> (T. W. Davies)
- Soothsaying, Methods of. . . . . 296<sup>a</sup>
- Sop. . . . . 2836<sup>a</sup>  
 cf Morsel. . . . . 2083<sup>a</sup>
- Sopater. . . . . 2836<sup>a</sup>  
 cf Pyrrhus. . . . . 2511<sup>b</sup>  
 cf Sosipater. . . . . 2837<sup>a</sup> (S. F. Hunter)
- Sope  
 cf Soap. . . . . 2820<sup>b</sup> (Patch)
- Sophereth. . . . . 2836<sup>a</sup>
- Sophists. . . . . 1017<sup>a</sup> (Alexander)
- Sophonias (Apoc). . . . . 2836<sup>a</sup>
- Sorcerer, Sorcery. . . . . 2836<sup>a</sup>  
 cf Astrology. . . . . 295<sup>b</sup> (Maunder)  
 cf Divination. . . . . 860<sup>a</sup> (T. W. Davies)  
 cf Magic. . . . . 1963<sup>a</sup> (T. W. Davies)  
 cf Resurrection. . . . . 2562<sup>b</sup> (Easton)  
 cf Witchcraft. . . . . 3097<sup>a</sup> (T. W. Davies)  
 cf Zoroastrianism. . . . . 3157<sup>a</sup> (Easton)
- Sore. . . . . 2836<sup>a</sup> (Macalister)
- Sorek, Valley of. . . . . 2836<sup>b</sup> (Masterman)
- Sorrel. . . . . 2836<sup>b</sup>  
 cf Colors. . . . . 674<sup>b</sup> (Patch)
- Sorrow. . . . . 2836<sup>b</sup> (W. L. Walker)
- Sortilege. . . . . 331<sup>b</sup> (T. W. Davies)
- Sosipater. . . . . 2837<sup>a</sup> (S. F. Hunter)  
 cf Sopater. . . . . 2836<sup>a</sup>
- Sosthenes. . . . . 2837<sup>a</sup>
- Sostratus. . . . . 2837<sup>a</sup> (Angus)
- Sotai. . . . . 2837<sup>a</sup>
- Sottish. . . . . 2837<sup>a</sup>
- Soul. . . . . 2837<sup>a</sup> (Marais)  
 NT meanings. . . . . 2837<sup>b</sup>  
 OT meanings. . . . . 2837<sup>a</sup>  
 cf Psychology. . . . . 2496<sup>b</sup> (Marais)  
 cf Resurrection. . . . . 2565<sup>a</sup> (Easton)
- Soul and spirit. . . . . 2838<sup>a</sup>



Soul—*continued*

- cf Spirit . . . . . 2841<sup>b</sup> (Marais)  
 Survival of . . . . . 1461<sup>a</sup>  
 Sound . . . . . 2838<sup>a</sup> (Easton)  
 cf Bath Kol . . . . . 415<sup>b</sup> (Van Pelt)  
 cf Solemn, Solemnity . . . . . 2821<sup>b</sup> (Easton)  
 Soundings  
 cf Ships and Boats . . . . . 2774<sup>a</sup> (Nicol)  
 Sour . . . . . 2838<sup>a</sup>  
 South . . . . . 2838<sup>a</sup> (Day)  
 cf Natural Features . . . . . 2122<sup>a</sup> (Day)  
 South, Chambers of the . . . . . 2838<sup>b</sup>  
 cf Astronomy . . . . . 300<sup>b</sup> (Maunder)  
 South, Queen of the  
 cf Queen of Sheba . . . . . 2514<sup>b</sup> (Roberts)  
 South Ramoth  
 cf Ramoth . . . . . 2529<sup>a</sup>  
 Southeast  
 cf Northeast . . . . . 2155<sup>b</sup> (Day)  
 Sow  
 cf Swine . . . . . 2875<sup>b</sup> (Day)  
 Sower, Sowing  
 cf Agriculture . . . . . 75<sup>b</sup> (Patch)  
 Spain . . . . . 2838<sup>b</sup>  
 cf Paul, the Apostle . . . . . 2264<sup>b</sup> (A. T. Robertson)  
 cf Tarshish . . . . . 2914<sup>a</sup>  
 Span . . . . . 2838<sup>b</sup>  
 cf Weights and Measures . . . . . 3079<sup>a</sup> (Porter)  
 Spark  
 cf Leviathan . . . . . 1868<sup>b</sup> (Day)  
 Sparrow . . . . . 2838<sup>b</sup> (Stratton-Porter)  
 Biblical references . . . . . 2839<sup>a</sup>  
 Description . . . . . 2838<sup>b</sup>  
 cf Food . . . . . 1124<sup>a</sup> (Eager)  
 Sparta, Spartans . . . . . 2839<sup>b</sup> (Orr)  
 cf Arius . . . . . 242<sup>a</sup>  
 cf Asmoneans . . . . . 283<sup>a</sup> (Dosker)  
 cf Lacedaemonians . . . . . 1819<sup>b</sup> (Hutchison)  
 cf Maccabaeus . . . . . 1946<sup>a</sup> (Hutchison)  
 Speaking Evil . . . . . 748<sup>a</sup> (Hirsch)  
 cf Evil-speaking . . . . . 1043<sup>a</sup> (W. L. Walker)  
 cf Slander . . . . . 2814<sup>b</sup> (Edwards)  
 Spear, Spearmen  
 cf Armor, Arms . . . . . 252<sup>a</sup> (Nicol)  
 Specially . . . . . 2839<sup>b</sup> (Clippinger)  
 Speckled . . . . . 2839<sup>b</sup>  
 cf Colors . . . . . 674<sup>b</sup> (Patch)  
 cf Hyena . . . . . 1443<sup>b</sup> (Day)  
 Spectacle . . . . . 2839<sup>b</sup>  
 Speech . . . . . 2839<sup>b</sup> (W. L. Walker)  
 cf Logos . . . . . 1911<sup>b</sup> (Alexander)  
 cf Word . . . . . 3105<sup>a</sup> (W. L. Walker)  
 Spelt . . . . . 2840<sup>a</sup>; 1122<sup>a</sup> (Eager)  
 Spice, Spices . . . . . 2840<sup>a</sup> (Masterman)  
 cf Burial . . . . . 529<sup>a</sup> (Eager)  
 cf Myrrh . . . . . 2102<sup>b</sup> (Masterman)  
 cf Perfume . . . . . 2321<sup>b</sup> (Patch)  
 cf Tragacanth . . . . . 3005<sup>a</sup>  
 cf Wine . . . . . 3086<sup>a</sup> (Easton)  
 Spider . . . . . 2840<sup>b</sup> (Day)  
 cf Gecko . . . . . 1181<sup>a</sup>

Spider—*continued*

- cf Insects . . . . . 1473<sup>a</sup> (Day)  
 cf Lizard . . . . . 1906<sup>a</sup> (Day)  
 Spies  
 cf Joshua, Son of Nun . . . . . 1744<sup>a</sup> (Geden)  
 Spikenard . . . . . 2840<sup>b</sup> (Masterman)  
 Spindle  
 cf Spinning . . . . . 2841<sup>a</sup> (Patch)  
 Spinning . . . . . 2841<sup>a</sup> (Patch)  
 cf Distaff . . . . . 859<sup>b</sup>  
 Spirit . . . . . 2841<sup>b</sup> (Marais)  
 cf Conscience . . . . . 701<sup>b</sup> (Stalker)  
 cf Flesh . . . . . 1118<sup>b</sup> (Luering)  
 cf Ghost . . . . . 1224<sup>b</sup> (W. L. Walker)  
 cf Holy Spirit . . . . . 1406<sup>a</sup> (Mullins)  
 Human and divine . . . . . 2842<sup>a</sup>  
 OT applications . . . . . 2842<sup>a</sup>  
 Primary and primitive  
 senses . . . . . 2841<sup>b</sup>  
 cf Psychology . . . . . 2496<sup>b</sup>; 2497<sup>b</sup> (Marais)  
 cf Resurrection . . . . . 2565<sup>a</sup> (Easton)  
 Shades of meaning . . . . . 2841<sup>b</sup>  
 cf Sinlessness . . . . . 2805<sup>b</sup> (Dunelm)  
 cf Soul . . . . . 2837<sup>a</sup> (Marais)  
 cf Spiritual . . . . . 2842<sup>b</sup> (Pratt)  
 cf Substance . . . . . 2868<sup>a</sup> (W. L. Walker)  
 Spirit of Divination  
 cf Divination . . . . . 860<sup>a</sup> (T. W. Davies)  
 Spirit, Evil  
 cf Demon, Demoniac . . . . . 827<sup>b</sup> (Sweet)  
 cf Satan . . . . . 2693<sup>b</sup> (Sweet)  
 Spirit, Familiar . . . . . 1094<sup>a</sup> (Pollard)  
 cf Divination . . . . . 860<sup>a</sup> (T. W. Davies)  
 cf Python . . . . . 2511<sup>b</sup> (Easton)  
 Spirit of God  
 cf God . . . . . 1253<sup>b</sup> (Rees)  
 Spirit, Holy . . . . . 1406<sup>a</sup> (Mullins)  
 Spirit, Unclean (or Evil)  
 cf Demon, Demoniac . . . . . 827<sup>b</sup> (Sweet)  
 Spirits, Discernings of . . . . . 851<sup>b</sup> (Fortune)  
 cf Spiritual Gifts . . . . . 2843<sup>a</sup> (Lambert)  
 Spirits in Prison . . . . . 2456<sup>b</sup> (Orr)  
 cf Hades . . . . . 1315<sup>b</sup> (Vos)  
 Spiritual . . . . . 2842<sup>b</sup> (Pratt)  
 cf Man, Natural . . . . . 1974<sup>a</sup> (Webb)  
 cf Spirit . . . . . 2841<sup>b</sup> (Marais)  
 cf Spiritual Man . . . . . 2844<sup>b</sup>  
 cf Spirituality . . . . . 2845<sup>b</sup> (Pratt)  
 Spiritual Blessing . . . . . 2843<sup>a</sup>  
 Spiritual Body . . . . . 2843<sup>a</sup>  
 Spiritual Drink . . . . . 2843<sup>a</sup>  
 cf Rock . . . . . 2596<sup>a</sup> (Day)  
 cf Spiritual Rock . . . . . 2845<sup>a</sup> (Pratt)  
 Spiritual Gifts . . . . . 2843<sup>a</sup> (Lambert)  
 cf Apostle . . . . . 202<sup>b</sup> (Lambert)  
 Connected with ministry . . . . . 2843<sup>b</sup>  
 Connected with practical service . . . . . 2844<sup>a</sup>  
 cf Discernings of  
 Spirits . . . . . 851<sup>b</sup> (Fortune)  
 cf Healing, Gifts of . . . . . 1349<sup>b</sup> (Lambert)

- Spiritual Gifts—*continued*  
 cf Helps . . . . . 1374<sup>a</sup> (Dosker)  
 cf Literature, Sub-  
   apos . . . . . 1896<sup>b</sup> (Cowan)  
 cf Salvation . . . . . 2669<sup>a</sup> (Easton)  
 cf Teach, Teacher,  
   Teaching . . . . . 2921<sup>b</sup> (DeMent)  
 Term . . . . . 2843<sup>a</sup>  
 Tongues . . . . . 2844<sup>a</sup>  
 cf Tongues, Gift of . . . . . 2995<sup>b</sup> (Easton)  
 Spiritual House . . . . . 2844<sup>b</sup>  
 Spirituality . . . . . 2845<sup>b</sup> (Pratt)  
 cf Spiritual Man . . . . . 2844<sup>b</sup>  
 Spiritually . . . . . 2845<sup>b</sup>  
 cf Spiritual . . . . . 2842<sup>b</sup> (Pratt)  
 Spiritual Man . . . . . 2844<sup>b</sup>  
 cf Man, New . . . . . 1975<sup>a</sup> (Webb)  
 cf Spiritual . . . . . 2842<sup>b</sup> (Pratt)  
 cf Spirituality . . . . . 2845<sup>b</sup> (Pratt)  
 Spiritual Meat . . . . . 2844<sup>b</sup> (Pratt)  
 Spiritual Rock . . . . . 2845<sup>a</sup> (Pratt)  
 cf Spiritual Drink . . . . . 2843<sup>a</sup>  
 Spiritual Sacrifice . . . . . 2845<sup>a</sup> (Pratt)  
 Spiritual Songs . . . . . 2845<sup>a</sup> (Pratt)  
 cf Song . . . . . 2830<sup>b</sup> (Millar)  
 Spiritual Things . . . . . 2845<sup>b</sup> (Pratt)  
 Spit, Spittle . . . . . 2846<sup>a</sup> (T. Lewis)  
 cf Face . . . . . 1085<sup>b</sup> (Luering)  
 Spoil  
 cf Booty . . . . . 503<sup>b</sup> (W. L. Walker)  
 cf Prey . . . . . 2439<sup>a</sup> (W. L. Walker)  
 cf War . . . . . 3069<sup>b</sup> (Nicol)  
 Spoiler . . . . . 2846<sup>a</sup>  
 Spoke  
 cf Wheel . . . . . 3082<sup>b</sup> (Easton)  
 Sponge . . . . . 2846<sup>a</sup> (Day)  
 Spoon . . . . . 2846<sup>a</sup>  
 Sports  
 cf Games . . . . . 1168<sup>b</sup> (Smith)  
 Spot, Spotted . . . . . 2846<sup>b</sup> (Macalister)  
 cf Blemish . . . . . 486<sup>b</sup> (Luering)  
 cf Freckled . . . . . 1145<sup>a</sup>  
 cf Leopard . . . . . 1866<sup>b</sup> (Day)  
 cf Leprosy . . . . . 1867<sup>a</sup> (Macalister)  
 cf Tetter . . . . . 2950<sup>a</sup>  
 Spouse . . . . . 2846<sup>b</sup>  
 cf Espousal . . . . . 997<sup>b</sup>  
 cf Marriage . . . . . 1996<sup>b</sup> (Eager)  
 cf Relationships, Fam-  
   ily . . . . . 2554<sup>a</sup> (N. and E. D. Isaacs)  
 Spread, Spreading . . . . . 2846<sup>b</sup>  
 Spring  
 cf Fountain . . . . . 1141<sup>b</sup> (Day)  
 cf Water . . . . . 3074<sup>a</sup> (Joy)  
 cf Well . . . . . 3081<sup>a</sup> (Day)  
 Sprinkle, Sprinkling . . . . . 2846<sup>b</sup> (T. Lewis)  
 cf Heifer, Red . . . . . 1367<sup>b</sup> (Easton)  
 Purification . . . . . 2847<sup>a</sup>  
 Words used . . . . . 2846<sup>b</sup>  
 Spurious Acts, Epistles,  
 Gospels  
 cf Apocryphal Acts . . . . . 183<sup>b</sup> (A. F. Findlay)  
 Spurious Acts, Epistles, Gospels—*continued*  
 cf Apocryphal Epistles 194<sup>b</sup> (J. M. Wilson)  
 cf Apocryphal Gospels 195<sup>a</sup> (Hutchison)  
 Spy  
 cf Espy . . . . . 997<sup>b</sup>  
 Stachys . . . . . 2847<sup>b</sup>  
 Stack . . . . . 2847<sup>b</sup>  
 Stacte . . . . . 2847<sup>b</sup>  
 cf Myrrh . . . . . 2102<sup>b</sup> (Masterman)  
 cf Spice, Spices . . . . . 2840<sup>a</sup> (Masterman)  
 Staff . . . . . 2847<sup>b</sup>  
 cf Sceptre . . . . . 2701<sup>b</sup> (N. Isaacs)  
 cf Shepherd . . . . . 2763<sup>a</sup> (Patch)  
 Stair  
 cf House . . . . . 1434<sup>b</sup> (A. C. Dickie)  
 Stake . . . . . 2847<sup>b</sup>  
 cf Pin . . . . . 2399<sup>a</sup> (N. Isaacs)  
 Stalk . . . . . 2847<sup>b</sup>  
 Stall . . . . . 2847<sup>b</sup> (Patch)  
 Stammerer . . . . . 2848<sup>a</sup>  
 Standard-bearer  
 cf Banner . . . . . 384<sup>a</sup> (Eager)  
 cf War . . . . . 3069<sup>b</sup> (Nicol)  
 Standards  
 cf Astronomy . . . . . 300<sup>b</sup> (Maunder)  
 cf Banner . . . . . 384<sup>a</sup> (Eager)  
 cf War . . . . . 3069<sup>b</sup> (Nicol)  
 Standing  
 cf Attitudes . . . . . 329<sup>a</sup> (W. W. Davies)  
 Star, Stars  
 cf Astronomy . . . . . 300<sup>b</sup> (Maunder)  
 Star of Bethlehem  
 cf Star of the Magi . . . . . 2848<sup>a</sup> (Maunder)  
 Star in the East  
 cf Magi . . . . . 1962<sup>a</sup> (Tisdall)  
 cf Star of the Magi . . . . . 2848<sup>a</sup> (Maunder)  
 Stargazers  
 cf Astrology . . . . . 297<sup>b</sup> (Maunder)  
 Star of the Magi . . . . . 2848<sup>a</sup> (Maunder)  
 Balaam's prophecy . . . . . 2848<sup>b</sup>  
 Herod's inquiry . . . . . 2848<sup>a</sup>  
 Lesson of narrative . . . . . 2849<sup>b</sup>  
 Magi, the . . . . . 2848<sup>a</sup>  
 Not astrological lore . . . . . 2848<sup>b</sup>  
 Not a conjunction . . . . . 2849<sup>a</sup>  
 Not a constellation . . . . . 2849<sup>a</sup>  
 Two facts . . . . . 2848<sup>b</sup>  
 Well of Bethlehem . . . . . 2849<sup>a</sup>  
 Star of Wormwood  
 cf Wormwood, The Star 3110<sup>a</sup> (Orr)  
 Stars, Courses of  
 cf Astronomy . . . . . 300<sup>b</sup> (Maunder)  
 Stars, Falling; Morning;  
 Wandering  
 cf Astronomy . . . . . 300<sup>b</sup> (Maunder)  
 Stars, Seven  
 cf Astronomy . . . . . 300<sup>b</sup> (Maunder)  
 Stately . . . . . 2850<sup>a</sup>  
 Stater . . . . . 2850<sup>a</sup>  
 cf Money . . . . . 2076<sup>a</sup> (Porter)  
 cf Shekel . . . . . 2758<sup>a</sup> (Porter)

- Stature . . . . . 2850<sup>a</sup> (Easton)  
 of Cubit . . . . . 765<sup>a</sup> (Porter)
- Staves . . . . . 2850<sup>a</sup> (Caldecott)  
 of Altar . . . . . 106<sup>b</sup> (Wiener)  
 of Rod . . . . . 2596<sup>b</sup> (Orr)  
 of Sceptre . . . . . 2701<sup>b</sup> (N. Isaacs)  
 of Staff . . . . . 2847<sup>b</sup>
- Stay . . . . . 2850<sup>a</sup> (Easton)
- Stead, Steads . . . . . 2850<sup>b</sup>
- Stealing  
 of Crimes . . . . . 748<sup>a</sup> (Hirsch)  
 of Punishments . . . . . 2504<sup>b</sup> (Hirsch)  
 of Thief . . . . . 2972<sup>a</sup> (Easton)
- Stedfastness . . . . . 2850<sup>b</sup>
- Steel . . . . . 2850<sup>b</sup>  
 of Brass . . . . . 514<sup>a</sup> (Patch)
- Stephanas . . . . . 2950<sup>b</sup> (Press)
- Stephen . . . . . 2850<sup>b</sup> (Press)  
 Character and activity 2857<sup>a</sup>  
 Defense . . . . . 2852<sup>a</sup>  
 of Law in NT . . . . . 1847<sup>a</sup> (M'Caig)  
 Martyrdom . . . . . 2853<sup>a</sup>  
 Personal antecedents . 2851<sup>a</sup>  
 Speech of Stephen . . . 2852<sup>b</sup>  
 Teaching . . . . . 2851<sup>a</sup>  
 Trial in Jerusalem . . . 2851<sup>b</sup>
- Steward . . . . . 2853<sup>b</sup> (Reeve)  
 of Melzar . . . . . 2030<sup>a</sup> (R. D. Wilson)  
 NT usage . . . . . 2853<sup>b</sup>  
 OT usage . . . . . 2853<sup>a</sup>
- Stewpan  
 of Pan . . . . . 2237<sup>a</sup> (Betteridge)
- Stiff-necked . . . . . 2854<sup>a</sup> (A. W. Evans)
- Still . . . . . 2854<sup>a</sup> (Easton)
- Sting . . . . . 2854<sup>b</sup> (Jacobs)
- Stir, Stir Up . . . . . 2854<sup>b</sup>
- Stock . . . . . 2854<sup>b</sup>  
 of Punishments . . . . . 2504<sup>b</sup> (Hirsch)
- Stoicism . . . . . 1018<sup>b</sup> (Alexander)  
 of Maccabees, Books  
 of . . . . . 1955<sup>a</sup> (T. W. Davies)
- Stoics . . . . . 2854<sup>b</sup> (Rees)  
 of Brotherly Kindness 525<sup>b</sup> (Rees)  
 of Epicureans . . . . . 964<sup>a</sup> (Rees)  
 Ethical teaching . . . . 2855<sup>a</sup>  
 of Logos . . . . . 1912<sup>b</sup> (Alexander)  
 Metaphysics and religion . . . . . 2855<sup>a</sup>  
 Origin and propagation . . . . . 2854<sup>b</sup>  
 of Philosophy . . . . . 2383<sup>a</sup> (Rees)  
 Relation to Christianity . . . . . 2855<sup>b</sup>  
 of Roman Empire and Christianity . . . . . 2600<sup>b</sup> (Angus)  
 Sensationalist epistemology . . . . . 2855<sup>a</sup>
- Stoics and Epicureans . . 1018<sup>a</sup> (Alexander)
- Stomach . . . . . 2855<sup>b</sup>
- Stomacher . . . . . 2856<sup>a</sup>
- Stone, Stones . . . . . 2856<sup>a</sup> (Day)  
 of Flint . . . . . 1119<sup>b</sup> (Day)
- Stone, Stones—*continued*  
 of Punishments . . . . . 2504<sup>b</sup> (Hirsch)  
 of Rock . . . . . 2596<sup>a</sup> (Day)  
 of Sela . . . . . 2713<sup>b</sup> (Ewing)
- Stone-squarers . . . . . 2856<sup>a</sup>
- Stones, Precious . . . . . 2856<sup>a</sup> (Fletcher)  
 of Adamant . . . . . 54<sup>a</sup> (Day)  
 Change of meaning . . . . 2856<sup>b</sup>  
 Different stones . . . . . 2858<sup>b</sup>  
 Hebrew names . . . . . 2857<sup>a</sup>  
 of Hyacinth . . . . . 1443<sup>b</sup>  
 Inconsistencies . . . . . 2857<sup>b</sup>  
 Interpretation of Greek names . . . . . 2856<sup>b</sup>  
 of Jewel . . . . . 1675<sup>b</sup> (Orr)  
 List of stones . . . . . 2856<sup>b</sup>  
 of Metal . . . . . 2044<sup>a</sup> (Masterman)  
 Names . . . . . 2856<sup>a</sup>  
 of Ouches . . . . . 2204<sup>b</sup> (Caldecott)  
 of Tarshish . . . . . 2914<sup>a</sup>  
 Various texts . . . . . 2858<sup>b</sup>
- Stoning  
 of Punishments . . . . . 2504<sup>b</sup> (Hirsch)
- Stool . . . . . 2862<sup>b</sup> (Cotton)  
 of Birth-stool . . . . . 478<sup>b</sup>  
 of Seat . . . . . 2710<sup>b</sup> (Cotton)
- Storax  
 of Poplar . . . . . 2421<sup>b</sup> (Masterman)  
 of Stacte . . . . . 2847<sup>b</sup>  
 of Tragacanth . . . . . 3005<sup>a</sup>
- Store-cities . . . . . 2863<sup>a</sup>  
 of Pithom . . . . . 2401<sup>b</sup> (Conder)  
 of Raamses . . . . . 2520<sup>a</sup> (Conder)
- Storehouses . . . . . 2863<sup>a</sup>  
 of Agriculture . . . . . 77<sup>b</sup> (Patch)
- Stories . . . . . 2863<sup>a</sup>  
 of Temple . . . . . 2930<sup>a</sup> (Caldecott; Orr)
- Stork . . . . . 2862<sup>a</sup> (Stratton-Porter)
- Storms  
 On Sea of Galilee . . . . 1166<sup>a</sup> (Ewing)
- Story  
 of Commentary . . . . . 687<sup>a</sup> (M. O. Evans)
- Story Telling  
 of Games . . . . . 1168<sup>b</sup> (Smith)
- Story Writer . . . . . 2863<sup>b</sup>
- Stout, Stoutness . . . . . 2863<sup>b</sup>
- Straight, Straightway . . . 2864<sup>a</sup> (Easton)
- Straight Street  
 of Damascus . . . . . 778<sup>a</sup> (C. H. Thomson)
- Strain . . . . . 2864<sup>a</sup>
- Strait, Straiten, Straitly . 2864<sup>a</sup> (M. O. Evans)
- Strakes (Strake) . . . . . 2864<sup>a</sup>  
 of Strike . . . . . 2867<sup>a</sup> (Easton)
- Strange Fire . . . . . 2864<sup>b</sup> (Dosker)
- Strange Gods . . . . . 1272<sup>a</sup> (Betteridge)
- Strange Wife . . . . . 2864<sup>b</sup>  
 of Stranger and Sojourner (in OT) . . . . . 2865<sup>a</sup> (Wiener)
- Strange Woman . . . . . 2865<sup>a</sup>  
 of Strange Wife . . . . . 2864<sup>b</sup>

- Stranger and Sojourner  
 (in OT) . . . . . 2865<sup>a</sup> (Wiener)  
 cf Cherethites . . . . . 603<sup>a</sup> (Ewing)  
 cf Commerce . . . . . 687<sup>b</sup> (Pollard)  
 cf Foreigner . . . . . 1128<sup>a</sup>  
 Foreigners, the . . . . . 2865<sup>b</sup>  
 cf Gentiles . . . . . 1215<sup>a</sup> (Porter)  
 Gēr, the . . . . . 2865<sup>a</sup>  
 Legal provisions . . . . . 2865<sup>a</sup>  
 cf Marriage . . . . . 1996<sup>b</sup> (Eager)  
 cf Pelethites . . . . . 2297<sup>a</sup>  
 cf Priests and Levites . 2452<sup>a</sup> (Wiener)  
 cf Proselyte . . . . . 2469<sup>a</sup> (Levertoff)  
 cf Relationships, Family . . . . . 2556<sup>b</sup> (N. and E. D. Isaacs)
- Stranger and Sojourner  
 (in Apoc and NT) . . . 2866<sup>a</sup> (Easton)
- Strangled . . . . . 2866<sup>a</sup> (Pollard)
- Strangling  
 cf Punishments . . . . . 2504<sup>b</sup> (Hirsch)
- Straw, Stubble . . . . . 2866<sup>b</sup> (Patch)
- Strawed . . . . . 2866<sup>b</sup>
- Stream . . . . . 2866<sup>b</sup> (Day)  
 cf Brook . . . . . 523<sup>b</sup> (Day)  
 cf Canals . . . . . 552<sup>a</sup> (Kyle)  
 cf Channel . . . . . 594<sup>a</sup> (Day)  
 cf River . . . . . 2595<sup>a</sup> (Day)  
 cf Vale . . . . . 3045<sup>a</sup> (Day)  
 cf Watercourse . . . . . 3074<sup>b</sup> (Day)
- Street  
 cf City . . . . . 662<sup>a</sup> (A. C. Dickie)
- Strength of Israel . . . . 2867<sup>a</sup>
- Strife, Waters of  
 cf Massah and Meribah . . . . . 2007<sup>a</sup> (Ewing)
- Strike, Striker, Stroke . . 2867<sup>a</sup> (Easton)  
 cf Sure, Surely . . . . . 2871<sup>b</sup> (Easton)  
 cf Surety . . . . . 2872<sup>a</sup> (Reeve)
- Stringed Instruments  
 cf Music . . . . . 2094<sup>b</sup> (Millar)
- Stripes  
 cf Punishments . . . . . 2504<sup>b</sup> (Hirsch)
- Strive  
 cf Games . . . . . 1168<sup>b</sup> (Smith)
- Stronghold  
 cf Fortification . . . . . 1136<sup>b</sup> (Nicol)
- Stubble . . . . . 2867<sup>b</sup>  
 cf Agriculture . . . . . 77<sup>a</sup> (Patch)  
 cf Rolling Thing . . . . . 2597<sup>b</sup>
- Studs . . . . . 2867<sup>b</sup>
- Stuff . . . . . 2867<sup>b</sup>
- Stumbling-block, Stumbling-stone . . . . . 2867<sup>b</sup> (Hovey)  
 cf Offence . . . . . 2179<sup>b</sup> (W. L. Walker)
- Sua . . . . . 2868<sup>a</sup>  
 cf Sia, Siaha . . . . . 2783<sup>a</sup>
- Suah . . . . . 2868<sup>a</sup>
- Subai . . . . . 2868<sup>a</sup>  
 cf Salmal . . . . . 2663<sup>b</sup>
- Sub-apostolic Literature . 1896<sup>b</sup> (Cowan)
- Subas . . . . . 2868<sup>a</sup>
- Suborn . . . . . 2868<sup>a</sup>
- Substance . . . . . 2868<sup>a</sup> (W. L. Walker)  
 cf Spirit . . . . . 2842<sup>a</sup> (Marais)
- Subtil, Subtle, Subtlety,  
 Subtly . . . . . 2868<sup>a</sup> (W. L. Walker)
- Suburbs  
 cf City . . . . . 662<sup>a</sup> (A. C. Dickie)
- Subvert . . . . . 2868<sup>b</sup> (W. L. Walker)
- Sucathites . . . . . 2868<sup>a</sup>
- Succeed, Success . . . . . 2868<sup>a</sup> (W. L. Walker)  
 cf Euodia . . . . . 1038<sup>a</sup> (Rutherford)
- Succor, Succorer . . . . . 2868<sup>b</sup> (W. L. Walker)
- Succoth . . . . . 2869<sup>a</sup> (Ewing)
- Succoth . . . . . 2869<sup>a</sup> (Conder)  
 cf Etham . . . . . 1012<sup>b</sup> (Conder)  
 cf Exodus . . . . . 1052<sup>a</sup> (Conder)  
 cf Pithom . . . . . 2401<sup>b</sup> (Conder)
- Succoth-benoth . . . . . 2869<sup>a</sup> (Pinches)  
 cf Gods . . . . . 1271<sup>a</sup> (Reeve)
- Suchathites  
 cf Sucathites . . . . . 2868<sup>b</sup>
- Sud  
 cf Sua . . . . . 2868<sup>a</sup>
- Sudias . . . . . 2869<sup>b</sup>  
 cf Hodevah . . . . . 1403<sup>a</sup>
- Suffering . . . . . 2869<sup>b</sup> (Luering)
- Suffocation  
 cf Punishments . . . . . 2504<sup>b</sup> (Hirsch)
- Suicide  
 cf Crimes . . . . . 748<sup>a</sup> (Hirsch)
- Sukkiim . . . . . 2870<sup>a</sup>
- Sulphur  
 cf Brimstone . . . . . 522<sup>b</sup> (Patch)
- Summer . . . . . 2870<sup>a</sup> (Porter)  
 cf Seasons . . . . . 2710<sup>b</sup> (Joy)
- Summer-house . . . . . 2870<sup>a</sup>  
 cf Winter-house . . . . . 3089<sup>a</sup>
- Sun  
 cf Astronomy . . . . . 301<sup>b</sup> (Maunder)
- Sun (figurative) . . . . . 2870<sup>a</sup> (Schenk)  
 cf Sun-worship . . . . . 2870<sup>b</sup> (Orr)
- Sun, Chariots of the  
 cf Horses of the Sun . . 1424<sup>a</sup>
- Sunday  
 cf Lord's Day . . . . . 1919<sup>a</sup> (Easton)
- Sun Gate  
 cf Gate, East . . . . . 1176<sup>b</sup> (Caldecott)
- Sun-god . . . . . 345<sup>a</sup> (Sayce)
- Sun, Horses of the . . . . . 1424<sup>a</sup>
- Sun-images  
 cf Images . . . . . 1452<sup>a</sup> (Cobern)
- Sunrising . . . . . 2870<sup>b</sup>
- Sun, Smiting by . . . . . 2870<sup>b</sup> (Macalister)  
 cf Moon . . . . . 2081<sup>a</sup> (Schenk)
- Sunstroke  
 cf Sun, Smiting by . . . 2870<sup>b</sup> (Macalister)
- Sun-worship . . . . . 2870<sup>b</sup> (Orr)  
 cf Beth-shemesh . . . . . 453<sup>a</sup> (Kyle)  
 cf Horses of the Sun . . 1424<sup>a</sup>  
 cf Sun (figurative) . . . 2870<sup>a</sup> (Schenk)
- Sup, Supper  
 cf Meals . . . . . 2013<sup>b</sup> (Eager)

- Superfluous, Superfluity . 2871<sup>a</sup> (T. Lewis)  
 Superscription . . . . . 2871<sup>a</sup> (Miller)  
   of Title . . . . . 2988<sup>b</sup>  
 Superstition, Superstitious . . . . . 2871<sup>a</sup> (Doolan)  
   of Religion . . . . . 2556<sup>b</sup> (Easton)  
 Suph . . . . . 2871<sup>a</sup> (Ewing)  
 Suphah . . . . . 2871<sup>b</sup> (Ewing)  
 Suppah  
   of Vaheb . . . . . 3044<sup>a</sup>  
 Supper  
   of Meals . . . . . 2013<sup>b</sup> (Eager)  
 Supper, Lord's . . . . . 1921<sup>b</sup> (Gummev)  
 Supply . . . . . 2871<sup>b</sup> (Easton)  
   of Add . . . . . 54<sup>b</sup> (M. O. Evans)  
   of Peter, Second Epistle  
     of . . . . . 2357<sup>a</sup> (Moorehead)  
 Sur . . . . . 2871<sup>b</sup>  
   of Jerusalem . . . . . 1595<sup>b</sup> (Masterman)  
 Sure, Surely . . . . . 2871<sup>b</sup> (Easton)  
   of Strike . . . . . 2867<sup>a</sup> (Easton)  
   of Surety . . . . . 2872<sup>a</sup> (Reeve)  
   of Undertake . . . . . 3037<sup>a</sup>  
 Surety . . . . . 2872<sup>a</sup> (Reeve)  
   of Debt, Debtor . . . . . 814<sup>a</sup> (W. Evans)  
   of Mortgage . . . . . 2083<sup>b</sup>  
   of Pledge . . . . . 2408<sup>b</sup> (Easton)  
   of Security . . . . . 2711<sup>b</sup> (Dosker)  
   of Strike . . . . . 2867<sup>a</sup> (Easton)  
   of Sure, Surely . . . . . 2871<sup>b</sup> (Easton)  
   of Undertake . . . . . 3037<sup>a</sup>  
 Surname . . . . . 2872<sup>b</sup> (T. Lewis)  
 Susa (Apoc)  
   of Shushan . . . . . 2782<sup>a</sup> (Pinches)  
 Susanchites  
   of Shushanchites . . . . . 2783<sup>a</sup>  
 Susanna, The History of 2872<sup>b</sup> (T. W. Davies)  
   of Bel and the Dragon . 427<sup>b</sup> (T. W. Davies)  
   Canonicity and position . . . . . 2872<sup>b</sup>  
   Contents . . . . . 2873<sup>a</sup>  
   of Daniel . . . . . 782<sup>b</sup> (R. D. Wilson)  
   Date . . . . . 2873<sup>b</sup>  
   Fact or fiction? . . . . . 2873<sup>a</sup>  
   of Holm Tree . . . . . 1405<sup>a</sup> (Masterman)  
   Name . . . . . 2872<sup>b</sup>  
   Original language . . . . . 2873<sup>b</sup>  
   of Text of the OT . . . . . 2957<sup>b</sup> (Wcir)  
   of Woman . . . . . 3102<sup>b</sup> (Pratt)  
 Susi . . . . . 2874<sup>a</sup>  
 Swaddle, Swaddling-band . . . . . 2874<sup>a</sup> (Easton)  
 Swallow . . . . . 2874<sup>a</sup> (Stratton-Porter)  
 Swan . . . . . 2874<sup>b</sup> (Stratton-Porter)  
 Swearing  
   of Crimes . . . . . 745<sup>b</sup> (Hirsch)  
   of Oath . . . . . 2172<sup>b</sup> (Levertoff)  
   of Punishments . . . . . 2504<sup>b</sup> (Hirsch)  
 Sweat . . . . . 2874<sup>b</sup> (Luering)  
 Sweet Cane  
   of Reed . . . . . 2544<sup>a</sup> (Masterman)  
 Sweet Incense  
   of Spices . . . . . 2840<sup>a</sup> (Masterman)  
 Swell . . . . . 2875<sup>a</sup> (Macalister)  
   of Swollen . . . . . 2876<sup>a</sup>  
 Swelling . . . . . 2875<sup>b</sup> (Easton)  
 Swift  
   of Swallow . . . . . 2874<sup>a</sup> (Stratton-Porter)  
 Swift Beasts . . . . . 2875<sup>b</sup>  
   of Camel . . . . . 547<sup>b</sup> (Day)  
   of Horse . . . . . 1423<sup>a</sup> (Day)  
 Swine . . . . . 2875<sup>b</sup> (Day)  
 Swollen . . . . . 2876<sup>a</sup>  
 Sword  
   of Armor, Arms . . . . . 252<sup>b</sup> (Nicol)  
 Sycamine Tree . . . . . 2876<sup>a</sup> (Masterman); 507<sup>b</sup>  
   (Masterman)  
   of Mulberry . . . . . 2093<sup>b</sup> (Masterman)  
 Sycamore  
   of Sycomore Tree . . . . . 2877<sup>a</sup> (Masterman)  
 Sychar . . . . . 2876<sup>b</sup> (Ewing)  
   of Jacob's Well . . . . . 1556<sup>b</sup> (Ewing)  
   of Shechem . . . . . 2755<sup>a</sup> (Ewing)  
 Sychem . . . . . 2877<sup>a</sup>  
 Sycomore Tree . . . . . 2877<sup>a</sup> (Masterman)  
   of Sycamine Tree . . . . . 2876<sup>a</sup> (Masterman)  
 Syene  
   of Seveneh . . . . . 2744<sup>a</sup>  
 Symeon . . . . . 2877<sup>b</sup>  
   of Peter (Simon) . . . . . 2348<sup>b</sup> (Gray)  
   of Simeon . . . . . 2794<sup>a</sup> (S. F. Hunter)  
 Symmachus  
   of Septuagint . . . . . 2726<sup>a</sup> (Thackeray)  
 Synagogue . . . . . 2877<sup>b</sup> (Levertoff); 238<sup>a</sup>  
   (A. C. Dickie)  
   Building . . . . . 2878<sup>b</sup>  
   of Chief Seats . . . . . 606<sup>b</sup> (J. M. Wilson)  
   of Education . . . . . 900<sup>b</sup> (Meyer)  
   Name . . . . . 2877<sup>b</sup>  
   Officials . . . . . 2878<sup>b</sup>  
   Origin . . . . . 2878<sup>a</sup>  
   Service . . . . . 2879<sup>a</sup>  
   Spread . . . . . 2878<sup>a</sup>  
 Synagogue, The Great . . . . . 2879<sup>b</sup> (Orr)  
   of Canon of the OT . . . . . 554<sup>a</sup> (Robinson)  
 Synagogue of Libertines  
   of Libertines . . . . . 1881<sup>a</sup> (S. F. Hunter)  
 Synagogue of Satan . . . . . 2696<sup>b</sup> (Williams)  
 Synoptic Gospels . . . . . 1281<sup>b</sup> (Iverach)  
 Syntyche . . . . . 2880<sup>a</sup> (Rutherford)  
   of Euodia . . . . . 1038<sup>a</sup> (Rutherford)  
   of Yokefellow . . . . . 3127<sup>a</sup> (Rutherford)  
 Synzygus . . . . . 2880<sup>a</sup>  
 Syracuse . . . . . 2880<sup>a</sup> (Allen)  
 Syria . . . . . 2880<sup>b</sup> (Christie)  
   History . . . . . 2881<sup>b</sup>  
   of Hittites . . . . . 1395<sup>b</sup> (Conder)  
   of Lebanon . . . . . 1862<sup>b</sup> (Wright)  
   Name and its origin . . . . . 2880<sup>b</sup>  
   of Natural Features . . . . . 2122<sup>a</sup> (Day)  
   Other designations . . . . . 2880<sup>b</sup>  
   of Palestine . . . . . 2208<sup>b</sup> (Conder)  
   of Phoenicia . . . . . 2386<sup>a</sup> (Porter)

Syria—*continued*

- Physical features . . . . . 2881<sup>a</sup>  
 cf Zobah . . . . . 3154<sup>b</sup> (Christie)
- Syriac . . . . . 2883<sup>a</sup>  
 cf Aramaic Language . 222<sup>a</sup> (J. E. H. Thomson)  
 cf Languages of the  
 OT . . . . . 1832<sup>a</sup> (Weir)
- Syriac Versions . . . . . 2883<sup>b</sup> (Nicol)  
 Analogy of Vulgate . . . 2883<sup>b</sup>  
 History of Peshito . . . 2885<sup>a</sup>  
 Old Syriac texts . . . . 2884<sup>a</sup>  
 Origin of Peshito . . . . 2884<sup>b</sup>  
 Other translations . . . 2885<sup>a</sup>  
 Peshito . . . . . 2883<sup>b</sup>  
 Syriac NT . . . . . 2884<sup>a</sup>  
 Syriac OT . . . . . 2883<sup>b</sup>
- Syria-maachah  
 cf Syria . . . . . 2880<sup>b</sup> (Christie)
- Syrian (AV Syriack) Language . . . . . 2885<sup>b</sup>
- Syrian Language  
 cf Syriac . . . . . 2883<sup>a</sup>
- Syrians . . . . . 2885<sup>b</sup> (Porter)  
 Division of Aram . . . . 2885<sup>b</sup>  
 Mixed race . . . . . 2886<sup>a</sup>  
 Nabathaeans and Palmyrenes . . . . . 2886<sup>a</sup>  
 Religion . . . . . 2886<sup>b</sup>  
 Semites . . . . . 2885<sup>b</sup>  
 Syria and Israel . . . . 2886<sup>a</sup>
- Syrophenician . . . . . 2886<sup>b</sup> (Ewing)
- Syrophenician Woman  
 cf Jesus Christ . . . . . 1648<sup>a</sup> (Orr)
- Syrtis . . . . . 2886<sup>b</sup>
- Syzygus  
 cf Synzygus . . . . . 2880<sup>a</sup>
- Taanach . . . . . 2887<sup>a</sup> (Ewing)  
 cf Palestine, Recent  
 Exploration . . . . . 2228<sup>a</sup> (Cobern)
- Taanath-shiloh . . . . . 2887<sup>a</sup> (Ewing)
- Tabaoth, Tabbaoth . . . . 2887<sup>a</sup>  
 cf Tabbath . . . . . 2887<sup>b</sup>
- Tabbath . . . . . 2887<sup>b</sup>
- Tabel . . . . . 2887<sup>b</sup> (Eiselen)  
 cf Tobiel . . . . . 2990<sup>b</sup>
- Tabellius . . . . . 2887<sup>b</sup>
- Taber . . . . . 2887<sup>b</sup>
- Taberah . . . . . 2887<sup>b</sup>
- Tabernacle A (structure and history) . . . . . 2887<sup>b</sup> (Caldecott; Orr)  
 cf Altar . . . . . 106<sup>b</sup> (Wiener)  
 cf Ark of Covenant . . . 242<sup>b</sup> (Lotz)  
 cf Candle . . . . . 552<sup>b</sup> (Eager)  
 cf Candlestick, Golden 553<sup>a</sup> (Orr)  
 cf Cherubim . . . . . 603<sup>b</sup> (Margolis)  
 cf Chronology of the  
 OT . . . . . 635<sup>a</sup> (Mack)  
 cf Court of Sanctuary . 725<sup>a</sup> (Caldecott)  
 Delocalization of worship . . . . . 2892<sup>a</sup>  
 Destruction of Shiloh . 2891<sup>b</sup>

Tabernacle A (structure and history)—*continued*

- Divisions . . . . . 2889<sup>b</sup>  
 Furniture of . . . . . 2890<sup>b</sup>; 1150<sup>a</sup> (Reeve)  
 cf Gate . . . . . 1175<sup>b</sup> (Easton)  
 cf Gate, East . . . . . 1176<sup>b</sup> (Caldecott)  
 History . . . . . 2891<sup>a</sup>  
 cf Holy of Holies . . . . 1405<sup>a</sup> (Caldecott)  
 cf Holy Place . . . . . 1405<sup>b</sup> (Caldecott)  
 cf Incense . . . . . 1466<sup>b</sup> (Orr)  
 Inclosure or court . . . . 2889<sup>a</sup>  
 Introductory . . . . . 2888<sup>a</sup>  
 cf Laver . . . . . 1843<sup>b</sup> (Caldecott)  
 cf Loop . . . . . 1919<sup>a</sup>  
 cf Mercy-seat . . . . . 2036<sup>a</sup> (Caldecott)  
 NT references . . . . . 2892<sup>b</sup>  
 cf Rams' Skins . . . . . 2530<sup>a</sup>  
 Removal from Sinai . . . 2891<sup>a</sup>  
 Restoration of the ark . 2892<sup>a</sup>  
 cf Sanctuary . . . . . 2686<sup>b</sup> (Wiener)  
 Settlement in Canaan . 2891<sup>b</sup>  
 cf Shewbread, Table of 2767<sup>b</sup> (Caldecott)  
 Sojourn at Kadesh . . . . 2891<sup>b</sup>  
 Stage in revelation . . . 2888<sup>b</sup>  
 Structure of the tabernacle . . . . . 2888<sup>b</sup>  
 Symbolism . . . . . 2892<sup>a</sup>  
 cf Tabernacle B . . . . . 2893<sup>a</sup> (Whitelaw)  
 Tent of Meeting . . . . . 2888<sup>a</sup>
- Tabernacle B (criticism) 2893<sup>a</sup> (Whitelaw)  
 Ability to construct  
 such a building in  
 the wilderness . . . . . 2895<sup>a</sup>  
 cf Chronology of the OT 635<sup>a</sup> (Mack)  
 Conservative and critical views . . . . . 2893<sup>a</sup>  
 cf Moses . . . . . 2087<sup>b</sup> (Kyle)  
 No tabernacle in pre-Solomonic times . . . . 2893<sup>b</sup>  
 Preëxilic prophets and the tabernacle cultus 2897<sup>a</sup>  
 Relation to temple . . . . 2893<sup>a</sup>  
 cf Shiloh (place) . . . . . 2768<sup>b</sup> (Ewing)  
 cf Tabernacle A . . . . . 2887<sup>b</sup> (Caldecott; Orr)
- Tabernacles at Shiloh,  
 Nob and Gibeon . . . . . 2893<sup>b</sup>  
 cf Tax, Taxing . . . . . 2918<sup>a</sup> (Sweet)  
 cf Temple . . . . . 2930<sup>b</sup> (Caldecott; Orr)  
 cf Tent . . . . . 2947<sup>b</sup> (Patch)  
 cf Twine . . . . . 3028<sup>a</sup>  
 Unhistorical character  
 of the narratives . . . . . 2895<sup>b</sup>  
 cf Veil . . . . . 3047<sup>a</sup> (Caldecott)  
 cf Witness . . . . . 3099<sup>a</sup> (Levertoff)  
 cf Worship . . . . . 3111<sup>a</sup> (Crannell)
- Tabernacle of Testimony  
 (Witness) . . . . . 2898<sup>a</sup>  
 cf Tabernacle A . . . . . 2892<sup>a</sup> (Caldecott; Orr)
- Tabernacles, Feast of  
 cf Feasts and Fasts . . . 1103<sup>a</sup> (E. D. Isaacs)  
 cf Wine . . . . . 3087<sup>a</sup> (Easton)
- Tabitha  
 cf Dorcas . . . . . 870<sup>a</sup> (S. F. Hunter)

- Table . . . . . 2898<sup>a</sup> (Easton)  
 of Meals . . . . . 2013<sup>b</sup> (Eager)  
 of Money-changers . . . . . 2080<sup>b</sup> (Pollard)  
 of Shewbread, Table of 2767<sup>b</sup> (Caldecott)  
 of Tablet . . . . . 2900<sup>a</sup> (Richardson)
- Table of Nations . . . . . 2898<sup>b</sup> (Pinches)  
 of Abraham . . . . . 18<sup>a</sup> (Boyd)  
 Date . . . . . 2900<sup>a</sup>  
 of Ham . . . . . 1323<sup>b</sup> (Pinches)  
 of Isles of the Gentiles 1511<sup>b</sup>  
 of Japheth . . . . . 1568<sup>b</sup> (Pinches)  
 of Jobab . . . . . 1688<sup>a</sup>  
 of Mizraim . . . . . 2069<sup>a</sup> (Kyle)  
 of Sabacans . . . . . 2629<sup>a</sup> (Pinches)  
 Scope . . . . . 2899<sup>a</sup>  
 of Semites, Semitic Religion . . . . . 2718<sup>a</sup> (Mack)  
 of Shem . . . . . 2759<sup>a</sup> (Pinches)  
 Sons of Ham . . . . . 2899<sup>a</sup>  
 Sons of Japheth . . . . . 2899<sup>a</sup>  
 Sons of Shem . . . . . 2899<sup>b</sup>  
 Table and its object, the . . . . . 2898<sup>b</sup>  
 Three races, the . . . . . 2899<sup>a</sup>  
 of Togarmah . . . . . 2993<sup>b</sup> (Pinches)  
 of Ur of the Chaldees 3039<sup>a</sup> (Clay)  
 Value of . . . . . 2900<sup>a</sup>
- Table of Shewbread . . . . . 2767<sup>b</sup> (Caldecott)  
 of Altar . . . . . 110<sup>a</sup> (Caldecott)
- Tablet . . . . . 2900<sup>a</sup> (Richardson)  
 Biblical references . . . . . 2900<sup>b</sup>  
 of Roll (Scroll) . . . . . 2597<sup>a</sup> (Richardson)  
 of Table . . . . . 2898<sup>a</sup> (Easton)  
 of Tell el-Amarna . . . . . 2925<sup>b</sup> (Kyle)  
 Term . . . . . 2900<sup>a</sup>  
 of Writing . . . . . 3121<sup>a</sup> (Richardson)
- Tabor . . . . . 2901<sup>a</sup> (Ewing)  
 of Gibeath . . . . . 1225<sup>b</sup> (Ewing)
- Tabor, Mount . . . . . 2901<sup>a</sup> (Ewing)  
 Appearance . . . . . 2901<sup>b</sup>  
 Events at . . . . . 2901<sup>a</sup>  
 Location . . . . . 2901<sup>a</sup>  
 Transfiguration . . . . . 2901<sup>b</sup>  
 of Transfiguration, Mount of . . . . . 3006<sup>a</sup> (Ewing)
- Tabor, Oak of . . . . . 2902<sup>a</sup> (Ewing)
- Tabret, Timbrel  
 of Music . . . . . 2094<sup>b</sup> (Millar)
- Tabrimmon . . . . . 2902<sup>a</sup>  
 of Ben-hadad . . . . . 435<sup>b</sup> (Nicol)  
 of Rimmon . . . . . 2594<sup>a</sup> (N. Isaacs)
- Taches  
 of Clasps . . . . . 665<sup>b</sup> (Caldecott)
- Tachmonite  
 of Tahchemonite . . . . . 2902<sup>b</sup>
- Tackling  
 of Ships and Boats . . . . . 2774<sup>a</sup> (Nicol)
- Tadmor . . . . . 2902<sup>a</sup> (Weir)  
 of Tamar (place) . . . . . 2907<sup>b</sup> (Ewing)
- Tahan, Tahanites . . . . . 2902<sup>a</sup>
- Tahapanes . . . . . 2902<sup>b</sup>
- Tahash . . . . . 2902<sup>b</sup>
- Tahath (person) . . . . . 2902<sup>b</sup>
- Tahath (place) . . . . . 2902<sup>b</sup>  
 of Wanderings of Israel . . . . . 3064<sup>a</sup> (Conder)
- Tahchemonite . . . . . 2902<sup>b</sup>  
 of Hachmonite . . . . . 1313<sup>b</sup> (Hovey)
- Tahpanhes . . . . . 2902<sup>b</sup> (Cobern)  
 Biblical references . . . . . 2902<sup>b</sup>  
 Excavations and discoveries . . . . . 2903<sup>a</sup>  
 Location . . . . . 2902<sup>b</sup>
- Tahpenes . . . . . 2903<sup>a</sup>  
 of Pharaoh . . . . . 2359<sup>a</sup> (Kyle)
- Tahrea . . . . . 2903<sup>a</sup>  
 of Tarea . . . . . 2910<sup>a</sup>
- Tahtim-hodshi  
 of Hittites . . . . . 1395<sup>b</sup> (Conder)  
 of Kadesh on Orontes 1789<sup>a</sup> (Christie)
- Tail . . . . . 2903<sup>a</sup> (Luering)  
 of Rump . . . . . 2627<sup>a</sup>
- Take . . . . . 2903<sup>b</sup> (Easton)
- Tale . . . . . 2904<sup>a</sup> (T. Lewis)  
 of Games . . . . . 1168<sup>b</sup> (Smith)  
 of Slander . . . . . 2814<sup>b</sup> (Edwards)
- Talent . . . . . 2904<sup>a</sup> (Porter)  
 of Money . . . . . 2076<sup>a</sup> (Porter)
- Talitha Cumi . . . . . 2904<sup>a</sup>
- Talmai . . . . . 2904<sup>a</sup>
- Talmon . . . . . 2904<sup>b</sup>  
 of Telem (person) . . . . . 2925<sup>b</sup>
- Talmud . . . . . 2904<sup>b</sup> (Strack); 685<sup>a</sup> (Oko)  
 Babylonian Talmud . . . . . 2906<sup>a</sup>  
 Contents and divisions 2905<sup>a</sup>  
 of Heifer, Red . . . . . 1367<sup>b</sup> (Easton)  
 Importance of . . . . . 2904<sup>b</sup>  
 Literature on . . . . . 2906<sup>b</sup>  
 Palestinian Talmud . . . . . 2906<sup>a</sup>  
 of Pharisees . . . . . 2364<sup>b</sup> (J. E. H. Thomson)  
 of Rabbi . . . . . 2522<sup>a</sup> (Pollard)  
 of Sanhedrin . . . . . 2688<sup>b</sup> (Levertoff)  
 Traditional law . . . . . 2905<sup>a</sup>  
 Verbal explanations . . . . . 2904<sup>b</sup>
- Talsas . . . . . 2907<sup>b</sup>  
 of Elasa . . . . . 923<sup>a</sup>  
 of Saloas . . . . . 2664<sup>a</sup>
- Tamah  
 of Temah . . . . . 2929<sup>a</sup>
- Tamar (person) . . . . . 2907<sup>b</sup> (Orr)  
 of Absalom . . . . . 23<sup>a</sup> (W. W. Davies)  
 of Amnon . . . . . 118<sup>a</sup>  
 of Judah . . . . . 1758<sup>a</sup> (Ewing)  
 of Maacah (person) . . . . . 1945<sup>a</sup> (Ewing)  
 of Tamar . . . . . 2964<sup>b</sup>
- Tamar (place) . . . . . 2907<sup>b</sup> (Ewing)  
 of Palm Tree . . . . . 2235<sup>a</sup> (Masterman)  
 of Tadmor . . . . . 2902<sup>a</sup> (Weir)
- Tamarisk . . . . . 2908<sup>a</sup> (Masterman); 507<sup>b</sup> (Masterman)
- Tammuz . . . . . 2903<sup>a</sup> (Porter); 372<sup>a</sup> (Rogers)  
 of Adonis . . . . . 58<sup>a</sup>  
 of Calendar . . . . . 541<sup>b</sup> (Porter)

- Tammuz—*continued*  
 of Gebal . . . . . 1180<sup>a</sup> (Porter)  
 of Phoenicia . . . . . 2387<sup>a</sup>; 2389<sup>b</sup> (Porter)
- Tanach  
 of Taanach . . . . . 2887<sup>a</sup> (Ewing)
- Tanhumeth . . . . . 2908<sup>a</sup>
- Tanis . . . . . 2908<sup>b</sup>  
 of Zoan . . . . . 3153<sup>a</sup> (Conder)
- Tanner . . . . . 2908<sup>b</sup> (Patch)  
 of Crafts . . . . . 734<sup>a</sup> (Patch)  
 of Dyeing . . . . . 883<sup>b</sup> (Patch)  
 Leather . . . . . 2909<sup>a</sup>  
 Method . . . . . 2908<sup>b</sup>  
 of Parchment . . . . . 2247<sup>b</sup> (Patch)  
 Simon, the . . . . . 2908<sup>b</sup>
- Tanning  
 of Wool . . . . . 3104<sup>b</sup> (Patch)
- Tapestry . . . . . 2909<sup>a</sup>  
 of Weaving . . . . . 3077<sup>a</sup> (Patch)
- Taphath . . . . . 2909<sup>a</sup>
- Taphon  
 of Tephon . . . . . 2948<sup>b</sup>
- Tappuah (person) . . . . . 2909<sup>b</sup>
- Tappuah (place) . . . . . 2909<sup>a</sup> (Ewing)
- Tarah  
 of Terah . . . . . 2948<sup>b</sup> (Easton)
- Taralah . . . . . 2909<sup>b</sup>
- Tarea . . . . . 2910<sup>a</sup>  
 of Tahrea . . . . . 2903<sup>a</sup>
- Tares . . . . . 2910<sup>a</sup>
- Target  
 of Mark (noun) . . . . . 1985<sup>b</sup> (Pratt)
- Targum . . . . . 2910<sup>a</sup> (J. E. H. Thomson);  
 685<sup>a</sup> (Oko)  
 Date . . . . . 2911<sup>a</sup>  
 Jonathan, Targum of . . . . . 2912<sup>b</sup>  
 Language of . . . . . 2910<sup>b</sup>  
 of Logos . . . . . 1913<sup>a</sup> (Alexander)  
 Meaning of term . . . . . 2910<sup>b</sup>  
 Mode of giving . . . . . 2911<sup>a</sup>  
 Onkelos, Targum of . . . . . 2911<sup>b</sup>  
 Origin . . . . . 2910<sup>b</sup>  
 Other Targums . . . . . 2913<sup>a</sup>  
 Use of . . . . . 2913<sup>b</sup>
- Tarpelites . . . . . 2914<sup>a</sup>
- Tarshish . . . . . 2914<sup>a</sup>  
 of Stones, Precious . . . . . 2862<sup>a</sup> (Fletcher)
- Tarshish, Navy (Ships) of  
 of Jehoshaphat . . . . . 1583<sup>a</sup> (Mosiman)  
 of Ships and Boats . . . . . 2774<sup>a</sup> (Nicol)
- Tarsus . . . . . 2914<sup>b</sup> (Tod)  
 Constitution of . . . . . 2916<sup>a</sup>  
 Foundation legends . . . . . 2914<sup>b</sup>  
 Later history . . . . . 2917<sup>a</sup>  
 of Paul, the Apostle . . . . . 2273<sup>a</sup> (A. T. Robertson)  
 Paul's home . . . . . 2916<sup>b</sup>  
 Roman period . . . . . 2915<sup>b</sup>  
 Situation . . . . . 2914<sup>b</sup>  
 Under Greek sway . . . . . 2915<sup>b</sup>  
 Under oriental power . . . . . 2915<sup>a</sup>  
 University at . . . . . 2916<sup>a</sup>
- Tartak . . . . . 2917<sup>a</sup>  
 of Gods . . . . . 1271<sup>a</sup> (Reeve)
- Tartan . . . . . 2917<sup>a</sup> (Eiselen)  
 of Rabsaris . . . . . 2522<sup>b</sup> (Clippinger)  
 of Rabshakeh . . . . . 2522<sup>b</sup> (Clippinger)
- Taskmaster . . . . . 2917<sup>a</sup> (Hirsch)
- Tassel . . . . . 2917<sup>b</sup> (Caldecott)  
 of Fringes . . . . . 1146<sup>b</sup> (E. D. Isaacs)
- Taste . . . . . 2917<sup>b</sup> (Luering)
- Tattenai . . . . . 2917<sup>b</sup> (Umbach)  
 of Sisinnus . . . . . 2813<sup>a</sup>
- Tattler . . . . . 2917<sup>b</sup>
- Tav  
 of Tav . . . . . 2918<sup>a</sup>
- Taverns, Three . . . . . 2918<sup>a</sup> (Allen)
- Taw . . . . . 2918<sup>a</sup>  
 of Alphabet . . . . . 103<sup>b</sup> (Richardson)  
 of Forehead . . . . . 1127<sup>b</sup> (Luering)  
 of Mark (noun) . . . . . 1985<sup>b</sup> (Pratt)
- Tax, Taxing . . . . . 2918<sup>a</sup> (Sweet)  
 General considerations 2918<sup>a</sup>  
 In Israel . . . . . 2918<sup>b</sup>  
 Publicans . . . . . 2920<sup>b</sup>  
 of Tabernacle . . . . . 2887<sup>b</sup> (Caldecott; Orr)  
 of Tribute . . . . . 3010<sup>b</sup> (Hirsch)  
 Under Assyria and  
 Babylonia . . . . . 2919<sup>a</sup>  
 Under Egypt and  
 Syria . . . . . 2920<sup>a</sup>  
 Under foreign conquer-  
 ors . . . . . 2919<sup>a</sup>  
 Under judges . . . . . 2918<sup>b</sup>  
 Under kings . . . . . 2918<sup>b</sup>  
 Under Persia . . . . . 2919<sup>b</sup>  
 Under Rome . . . . . 2920<sup>a</sup>
- Teach, Teacher, Teach-  
 ing . . . . . 2921<sup>a</sup> (DeMent)  
 Apostolic work . . . . . 2923<sup>a</sup>  
 of Catechist . . . . . 582<sup>b</sup> (Gerberding)  
 Christ's work of teach-  
 ing . . . . . 2923<sup>a</sup>  
 of Didache . . . . . 387<sup>b</sup> (A. T. Robertson)  
 of Education . . . . . 900<sup>b</sup> (Meyer)  
 Extra-Biblical history 2922<sup>b</sup>  
 NT history . . . . . 2923<sup>a</sup>  
 NT terms . . . . . 2922<sup>a</sup>  
 OT history . . . . . 2922<sup>b</sup>  
 OT terms . . . . . 2921<sup>a</sup>  
 of Spiritual Gifts . . . . . 2843<sup>b</sup> (Lambert)  
 Terms for, in OT . . . . . 2921<sup>a</sup>
- Tear Bottle . . . . . 2923<sup>b</sup>
- Tears . . . . . 2923<sup>b</sup> (Macalister)  
 of Bottle . . . . . 509<sup>b</sup> (Eager)
- Teat . . . . . 2923<sup>b</sup>  
 of Pap . . . . . 2237<sup>b</sup>
- Tebah . . . . . 2924<sup>a</sup>
- Tebaliah . . . . . 2924<sup>a</sup>  
 of Tobijah . . . . . 2990<sup>b</sup>
- Tebeth . . . . . 2924<sup>a</sup>  
 of Calendar . . . . . 541<sup>b</sup> (Porter)
- Tehaphnehes  
 of Tahpanhes . . . . . 2902<sup>b</sup> (Cobern)



- Tehinnah . . . . . 2924<sup>a</sup>  
 Teil Tree . . . . . 2924<sup>a</sup>  
 of Terebinth . . . . . 2949<sup>a</sup> (Masterman)  
 Tekel  
   of Mene, Mene, Tekel,  
     Upharsin . . . . . 2032<sup>a</sup> (R. D. Wilson)  
 Tekoa . . . . . 2924<sup>a</sup> (Masterman)  
   Later history . . . . . 2924<sup>b</sup>  
   Scripture references . . . . . 2924<sup>a</sup>  
   Site . . . . . 2924<sup>b</sup>  
 Tel-abib . . . . . 2924<sup>b</sup> (Pinches)  
 Telah . . . . . 2925<sup>a</sup>  
 Telaim . . . . . 2925<sup>a</sup> (Masterman)  
 Telassar . . . . . 2925<sup>a</sup> (Pinches)  
   of Eden . . . . . 897<sup>b</sup> (Wright)  
   of Rosh . . . . . 2623<sup>b</sup> (Pinches)  
 Telem (person) . . . . . 2925<sup>b</sup>  
   of Talmon . . . . . 2904<sup>b</sup>  
   of Tolbanes . . . . . 2994<sup>a</sup>  
 Telem (place) . . . . . 2925<sup>a</sup>  
   of Telaim . . . . . 2925<sup>a</sup> (Masterman)  
 Tel-harsha . . . . . 2925<sup>a</sup>  
 Tell  
   of Tale . . . . . 2904<sup>a</sup> (T. Lewis)  
 Tell el-Amarna Tablets . . . . . 2925<sup>b</sup> (Kyle)  
   of Archaeology and  
     Criticism . . . . . 226<sup>a</sup> (Kyle)  
   Canaanite civilization . . . . . 2927<sup>a</sup>  
   Cuneiform writing . . . . . 2926<sup>a</sup>  
   Diplomatic correspond-  
     ence . . . . . 2927<sup>b</sup>  
   Discovery . . . . . 2925<sup>b</sup>  
   Egyptian rule, but  
     Babylonian lan-  
     guage . . . . . 2927<sup>b</sup>  
   Geographical value . . . . . 2926<sup>b</sup>  
   of Heberites . . . . . 1354<sup>b</sup>  
   of Hebrew . . . . . 1355<sup>a</sup> (Orr)  
   Historical value . . . . . 2926<sup>b</sup>  
   of Jerusalem . . . . . 1613<sup>b</sup> (Masterman)  
   of Libraries . . . . . 1882<sup>a</sup> (Richardson)  
   of Melchizedek . . . . . 2028<sup>b</sup> (Roberts)  
   of Moses . . . . . 2083<sup>b</sup> (Kyle)  
   Name . . . . . 2925<sup>b</sup>  
   of Palestine, Recent  
     Exploration . . . . . 2223<sup>a</sup> (Cobern)  
   Philological value . . . . . 2926<sup>b</sup>  
   Physical character . . . . . 2926<sup>a</sup>  
   Problem of the Habiri . . . . . 2927<sup>b</sup>  
   Proper names . . . . . 2926<sup>a</sup>  
   of Sidon . . . . . 2785<sup>a</sup> (Porter)  
   Verification of Biblical  
     statements . . . . . 2926<sup>b</sup>  
 Tell el-Hesy (Lachish)  
   of Palestine, Recent  
     Exploration . . . . . 2225<sup>b</sup> (Cobern)  
 Tel-melah . . . . . 2928<sup>b</sup>  
   of Tel-harsha . . . . . 2925<sup>a</sup>  
 Tema . . . . . 2928<sup>b</sup> (Ewing)  
 Temah  
   of Thomei . . . . . 2973<sup>b</sup>  
 Teman . . . . . 2929<sup>a</sup> (Ewing)  
 Temeni . . . . . 2929<sup>a</sup>  
 Temper . . . . . 2929<sup>a</sup> (T. Lewis)  
 Temperance, Temperate . . . . . 2929<sup>b</sup> (Jacobs)  
   of Abstinence . . . . . 24<sup>b</sup> (Eager)  
   of Drink, Strong . . . . . 879<sup>b</sup> (Edwards)  
   of Sobriety . . . . . 2820<sup>b</sup> (Jacobs)  
 Tempest . . . . . 2929<sup>b</sup> (Joy)  
 Temple A (structure and  
   history) . . . . . 2930<sup>a</sup> (Caldecott; Orr)  
   of Adytum . . . . . 65<sup>a</sup>  
   of Altar . . . . . 106<sup>b</sup> (Wiener)  
   of Altar of Burnt Offer-  
     ing . . . . . 110<sup>b</sup> (Caldecott)  
   of Architecture . . . . . 234<sup>a</sup> (A. C. Dickie)  
   of Asmoneans . . . . . 283<sup>a</sup> (Dosker)  
   of Boaz . . . . . 491<sup>a</sup> (Roberts); 1547<sup>b</sup>  
     (Caldecott)  
   of Candlestick, Golden . . . . . 553<sup>a</sup> (Orr)  
   of Cherubim . . . . . 603<sup>b</sup> (Margolis)  
   of Court of the Sanc-  
     tuary . . . . . 725<sup>a</sup> (Caldecott)  
   of Cubit . . . . . 765<sup>a</sup> (Porter)  
   of Furniture . . . . . 1150<sup>a</sup> (Reeve)  
   of Gate . . . . . 1175<sup>b</sup> (Easton)  
   of Gate, The Beautiful . . . . . 1176<sup>b</sup> (Caldecott)  
   of Holy of Holies . . . . . 1405<sup>a</sup> (Caldecott)  
   of Holy Place . . . . . 1405<sup>b</sup> (Caldecott)  
   of House . . . . . 1434<sup>b</sup> (A. C. Dickie)  
   of Incense . . . . . 1466<sup>b</sup> (Orr)  
   of Jachin and Boaz . . . . . 1547<sup>b</sup> (Caldecott)  
   of Jerusalem . . . . . 1618<sup>b</sup> (Masterman)  
   of Jesus Christ . . . . . 1637<sup>b</sup> (Orr)  
   of Knop . . . . . 1815<sup>b</sup>  
   of Laver . . . . . 1843<sup>b</sup> (Caldecott)  
   of Ledge . . . . . 1864<sup>b</sup>  
   of Lily-work . . . . . 1893<sup>b</sup>  
   of Maccabees, Books of . . . . . 1952<sup>a</sup> (T. W. Davies)  
   Of Onias . . . . . 237<sup>a</sup> (A. C. Dickie)  
   of Palace . . . . . 2208<sup>a</sup> (Orr)  
   of Partition, Middle  
     Wall of . . . . . 2253<sup>a</sup> (Rutherford)  
   of Porch . . . . . 2421<sup>b</sup>  
   of Porch, Solomon's . . . . . 2421<sup>b</sup> (Caldecott)  
   of Reed, Measuring . . . . . 2545<sup>a</sup> (Orr)  
   of Sanctuary . . . . . 2686<sup>b</sup> (Wiener)  
   of Sea, The Molten, or  
     Brazen . . . . . 2708<sup>a</sup> (Caldecott)  
   of Settle (noun) . . . . . 2743<sup>b</sup>  
   of Shewbread, Table of . . . . . 2767<sup>b</sup> (Caldecott)  
   of Shiloh (place) . . . . . 2768<sup>b</sup> (Ewing)  
   Of Siah . . . . . 238<sup>a</sup>  
   of Singers, Singing . . . . . 2804<sup>b</sup> (Millar)  
   of Solomon . . . . . 2824<sup>a</sup> (Weir)  
   Of Solomon . . . . . 234<sup>b</sup> (A. C. Dickie)  
   of Stories . . . . . 2863<sup>a</sup>  
   of Tabernacle B (criti-  
     cism) . . . . . 2893<sup>a</sup> (Whitelaw)  
   of Treasure, Treasurer,  
     Treasury . . . . . 3007<sup>b</sup> (Raffety)  
   of Treasury (of Tem-  
     ple) . . . . . 3008<sup>a</sup> (Caldecott)  
   of Upper Chamber . . . . . 3039<sup>a</sup> (Orr)

- Temple A (structure and history)—*continued*  
 cf Veil . . . . . 3047<sup>a</sup> (Caldecott)  
 cf Worship . . . . . 3111<sup>a</sup> (Crannell)  
 cf Zacharias . . . . . 3129<sup>b</sup> (Easton)
- Temple B (in criticism) . 2940<sup>a</sup> (Whitelaw)  
 Central sanctuary . . . 2942<sup>b</sup>  
 Challenge of criticism. 2940<sup>a</sup>  
 Errors in Chronicles. . 2941<sup>a</sup>  
 Errors as to David. . . 2941<sup>a</sup>  
 Omissions and contra-  
 dictions . . . . . 2941<sup>a</sup>  
 Plan of the temple. . . 2941<sup>b</sup>  
 Quantity of material. . 2941<sup>b</sup>  
 Service of . . . . . 2942<sup>a</sup>  
 Versions different. . . 2940<sup>b</sup>
- Temple (Ezekiel's) . . . . 2934<sup>b</sup> (Caldecott; Orr)  
 Buildings and adjuncts 2935<sup>b</sup>  
 Courts . . . . . 2935<sup>a</sup>  
 Relation to history of  
 the temple. . . . . 2934<sup>b</sup>
- Temple (Herod's) . . . . . 2937<sup>a</sup> (Caldecott; Orr)  
 Apostolic church. . . . 2939<sup>b</sup>  
 Beginning of work . . . 2937<sup>a</sup>  
 cf Gate, The Beautiful. 1176<sup>b</sup> (Caldecott)  
 Grandeur of . . . . . 2937<sup>a</sup>  
 cf Holy of Holies. . . . 1405<sup>a</sup> (Caldecott)  
 Inner sanctuary . . . . 2937<sup>b</sup>  
 Jesus in the. . . . . 2939<sup>a</sup>  
 NT references to . . . . 2939<sup>a</sup>  
 Passion Week . . . . . 2939<sup>b</sup>  
 Temple area . . . . . 2937<sup>a</sup>  
 Temple building, the. . 2938<sup>b</sup>  
 Temple in Christian  
 thought . . . . . 2939<sup>b</sup>  
 cf Treasury (of Tem-  
 ple) . . . . . 3008<sup>a</sup> (Caldecott)
- Temple (Solomon's) . . . . 2930<sup>b</sup> (Caldecott; Orr)  
 Building, the. . . . . 2931<sup>a</sup>  
 Courts . . . . . 2932<sup>b</sup>  
 David's plan . . . . . 2930<sup>b</sup>  
 Furniture of court . . . 2933<sup>b</sup>  
 Furniture of sanctuary 2933<sup>b</sup>  
 History of . . . . . 2934<sup>a</sup>  
 Phoenician help . . . . 2931<sup>a</sup>  
 Plans and character. . 2930<sup>b</sup>  
 Porch and pillars . . . 2932<sup>a</sup>  
 Royal buildings . . . . 2933<sup>a</sup>  
 Side chambers. . . . . 2932<sup>a</sup>  
 Site . . . . . 2930<sup>b</sup>
- Temple (Zerubbabel's) . . 2936<sup>a</sup> (Caldecott; Orr)  
 Building and furniture 2936<sup>b</sup>  
 Decree of Cyrus . . . . 2936<sup>a</sup>  
 Founding and comple-  
 tion . . . . . 2936<sup>a</sup>  
 Later fortunes . . . . . 2936<sup>b</sup>
- Temple Keepers (Serv-  
 ants) . . . . . 2942<sup>b</sup> (Easton)  
 cf Nethinim . . . . . 2139<sup>b</sup> (Lees)
- Temples . . . . . 2942<sup>b</sup>  
 Temples, Robbers of . . 2942<sup>b</sup> (Jacobs)
- Tempt, Temptation . . . . 2942<sup>b</sup> (Stuart)  
 cf Buddha . . . . . 1635<sup>b</sup> (Orr)
- Tempt, Temptation—*continued*  
 cf Prove . . . . . 2469<sup>b</sup> (W. L. Walker)  
 cf Temptation of  
 Christ . . . . . 2943<sup>a</sup> (Anderson)
- Temptation of Christ . . . 2943<sup>a</sup> (Anderson); 1806<sup>b</sup>  
 (Stalker)
- Character of the narra-  
 tive . . . . . 2944<sup>a</sup>  
 First temptation . . . . 2943<sup>b</sup>  
 cf Gethsemane . . . . . 1221<sup>b</sup> (Masterman)  
 How he tempted if sin-  
 less? . . . . . 2944<sup>b</sup>  
 cf Jesus Christ . . . . . 1635<sup>a</sup> (Orr)  
 cf Points . . . . . 2415<sup>a</sup> (M. O. Evans)  
 cf Satan . . . . . 2694<sup>b</sup> (Sweet)  
 Second temptation . . . 2943<sup>b</sup>  
 Significance . . . . . 2943<sup>a</sup>  
 cf Tempt, Temptation. 2942<sup>b</sup> (Stuart)  
 Third temptation . . . . 2944<sup>a</sup>  
 Time, place and  
 sources . . . . . 2943<sup>a</sup>
- Ten  
 cf Number . . . . . 2157<sup>a</sup> (Smith)
- Ten Commandments,  
 The . . . . . 2944<sup>b</sup> (Sampey)  
 Exegetical notes . . . . 2946<sup>a</sup>  
 cf Family . . . . . 1094<sup>b</sup> (Caverno)  
 Groups . . . . . 2945<sup>b</sup>  
 How numbered? . . . . 2945<sup>a</sup>  
 An Israelite code . . . 2944<sup>b</sup>  
 Jesus and the Deca-  
 logue . . . . . 2946<sup>b</sup>  
 Original form . . . . . 2945<sup>b</sup>  
 Promulgation . . . . . 2945<sup>a</sup>  
 cf Sabbath . . . . . 2629<sup>b</sup> (Sampey)
- Ten Strings  
 cf Music . . . . . 2094<sup>b</sup> (Millar)
- Ten Tribes in Captivity. 571<sup>b</sup> (Nicol)
- Tender . . . . . 2947<sup>a</sup> (Easton)  
 cf Blindness . . . . . 487<sup>b</sup> (Macalister)
- Tenon . . . . . 2947<sup>a</sup> (Caldecott)  
 cf Socket . . . . . 2821<sup>a</sup> (Caldecott)  
 cf Tabernacle . . . . . 2890<sup>a</sup> (Caldecott; Orr)
- Tent . . . . . 2947<sup>b</sup> (Patch)  
 Arab customs . . . . . 2947<sup>b</sup>  
 Biblical references . . 2947<sup>b</sup>  
 Figurative use . . . . . 2948<sup>a</sup>  
 cf Goat's Hair . . . . . 1249<sup>b</sup> (Patch)  
 cf Weaving . . . . . 3077<sup>a</sup> (Patch)
- Tenth  
 cf Tithe . . . . . 2987<sup>b</sup> (Levertoff)
- Tenth Deal . . . . . 2948<sup>a</sup>
- Tent-maker . . . . . 2948<sup>a</sup>  
 cf Crafts . . . . . 734<sup>a</sup> (Patch)
- Tephon . . . . . 2948<sup>b</sup>
- Terah (person) . . . . . 2948<sup>b</sup> (Easton)
- Terah (place) . . . . . 2949<sup>a</sup>  
 cf Wanderings of Israel 3064<sup>a</sup> (Conder)
- Teraphim  
 cf Astrology . . . . . 295<sup>b</sup> (Maunder)  
 cf Divination . . . . . 860<sup>a</sup> (T. W. Davies)  
 cf Gods . . . . . 1270<sup>b</sup> (Reeve)

Teraphim—*continued*

- cf Idolatry . . . . . 1447<sup>b</sup> (Cobern)  
 cf Image . . . . . 1450<sup>a</sup> (Edwards)  
 cf Images . . . . . 1452<sup>a</sup> (Cobern)  
 cf Jacob . . . . . 1551<sup>a</sup> (Boyd)
- Terebinth . . . . . 2949<sup>a</sup> (Masterman); 508<sup>a</sup>  
 (Masterman)  
 of Oak . . . . . 2171<sup>a</sup> (Masterman)
- Teresh . . . . . 2949<sup>a</sup>
- Terrace . . . . . 2949<sup>a</sup>
- Terrible, Terror . . . . . 2949<sup>b</sup> (M. O. Evans)
- Tertius . . . . . 2949<sup>b</sup> (S. F. Hunter)
- Tertullus . . . . . 2949<sup>b</sup> (Kerr)  
 cf Felix Antonius . . . . . 1105<sup>b</sup> (Kerr)
- Testament . . . . . 2950<sup>a</sup>  
 Of Abraham . . . . . 177<sup>a</sup>  
 Of Adam . . . . . 177<sup>a</sup>  
 of Covenant in the  
 NT . . . . . 729<sup>b</sup> (Estes); 175<sup>a</sup> (J. E.  
 H. Thomson)  
 Of Job . . . . . 177<sup>a</sup>  
 Of the twelve patri-  
 archs . . . . . 175<sup>a</sup>
- Testament of Isaac  
 cf Apocalyptic Litera-  
 ture . . . . . 161<sup>b</sup> (J. E. H. Thomson)
- Testament, New, Canon  
 of the . . . . . 563<sup>a</sup> (Riggs)
- Testament, New, Text  
 and Manuscripts . . . . . 2950<sup>b</sup> (Sitterly)
- Testament, Old, Canon of  
 the . . . . . 554<sup>a</sup> (Robinson)  
 cf Text of the OT . . . . . 2957<sup>b</sup> (Weir)
- Testaments, Between the 455<sup>a</sup> (Dosker)
- Testaments of the Twelve  
 Patriarchs  
 cf Apocalyptic Litera-  
 ture . . . . . 161<sup>b</sup> (J. E. H. Thomson)
- Testimony, Ark of the  
 cf Ark of the Cove-  
 nant . . . . . 242<sup>b</sup> (Lotz)
- Teta  
 cf Ateta . . . . . 317<sup>b</sup>
- Teth . . . . . 2950<sup>a</sup>  
 cf Alphabet . . . . . 103<sup>b</sup> (Richardson)
- Tetrarch . . . . . 2950<sup>a</sup> (Dosker)
- Tetter . . . . . 2950<sup>a</sup>  
 cf Freckled . . . . . 1145<sup>a</sup>  
 cf Leprosy . . . . . 1867<sup>a</sup> (Macalister)  
 cf Spot, Spotted . . . . . 2846<sup>b</sup> (Macalister)
- Text and Manuscripts of  
 the NT . . . . . 2950<sup>b</sup> (Sitterly)  
 Autograph copies . . . . . 2950<sup>b</sup>  
 Evidence abundant . . . . . 2950<sup>b</sup>  
 Four groups of texts . . . . . 2956<sup>b</sup>  
 Greek copies or manu-  
 scripts . . . . . 2952<sup>a</sup>  
 History of textual criti-  
 cism . . . . . 2956<sup>b</sup>  
 Lectionaries and serv-  
 ice books . . . . . 2954<sup>b</sup>

Text and Manuscripts of the NT—*continued*

- List of manuscripts . . . . . 2952<sup>a</sup>  
 cf Manuscripts . . . . . 1984<sup>a</sup> (Richardson)
- Methods of criticism . . . . . 2955<sup>b</sup>
- Necessity for criticism  
 of evidence . . . . . 2955<sup>a</sup>
- Papyrus fragments . . . . . 2952<sup>a</sup>
- Patristic quotations . . . . . 2954<sup>a</sup>
- Periods of textual  
 criticism . . . . . 2957<sup>a</sup>  
 cf Print . . . . . 2455<sup>a</sup> (Richardson)
- cf Septuagint . . . . . 2727<sup>b</sup> (Thackeray)
- Sources of evidence . . . . . 2950<sup>b</sup>
- Types of error . . . . . 2955<sup>a</sup>
- Vernacular versions . . . . . 2954<sup>a</sup>
- Text of the OT . . . . . 2957<sup>b</sup> (Weir)  
 cf Alphabet . . . . . 103<sup>b</sup> (Richardson)
- Alteration of docu-  
 ments . . . . . 2961<sup>a</sup>  
 Change in the law . . . . . 2959<sup>a</sup>  
 Change of script . . . . . 2959<sup>a</sup>  
 Chapter and verses . . . . . 2963<sup>b</sup>  
 Date of vowel points . . . . . 2962<sup>b</sup>  
 Division into books . . . . . 2962<sup>b</sup>  
 Divisions into verses . . . . . 2962<sup>a</sup>  
 Earliest form of writ-  
 ing . . . . . 2958<sup>a</sup>  
 Early printed texts . . . . . 2963<sup>b</sup>  
 Euphemisms . . . . . 2961<sup>a</sup>  
 External circumstances  
 of preservation . . . . . 2959<sup>b</sup>  
 History of the text . . . . . 2961<sup>b</sup>  
 Inscriptions . . . . . 2958<sup>b</sup>  
 Internal conditions of  
 preservation . . . . . 2959<sup>b</sup>  
 Inversion and abbrevi-  
 ation . . . . . 2960<sup>b</sup>  
 Jehovah and Baal . . . . . 2961<sup>a</sup>  
 cf Languages of the  
 Old Testament . . . . . 1833<sup>a</sup> (Weir)
- Letters and punctua-  
 tion marks . . . . . 2960<sup>a</sup>  
 of Manasses, Prayer of 1980<sup>a</sup> (T. W. Davies)
- Manuscripts and print-  
 ed texts . . . . . 2963<sup>b</sup>  
 Masorah, the . . . . . 2963<sup>a</sup>  
 New or Aramaean al-  
 phabet . . . . . 2958<sup>b</sup>  
 Old Hebrew alphabet . . . . . 2958<sup>b</sup>  
 Palestinian consonants,  
 vowels and accents . . . . . 2963<sup>b</sup>  
 Palestinian vowel  
 points . . . . . 2962<sup>b</sup>  
 Preservation of the  
 text . . . . . 2959<sup>b</sup>  
 Scribal alteration . . . . . 2961<sup>b</sup>  
 Scribal errors . . . . . 2961<sup>b</sup>  
 cf Seal . . . . . 2708<sup>a</sup> (Edwards)
- Sections in law, proph-  
 ets, etc . . . . . 2962<sup>a</sup>  
 Septuagint version . . . . . 2960<sup>a</sup>

- Text of the OT—*continued*  
 Text in the first cen-  
 tury AD . . . . . 2960<sup>a</sup>  
 Two Hebrew scripts . . . 2958<sup>b</sup>  
 Types of error in text . 2961<sup>b</sup>  
 Vocalization of the  
 text . . . . . 2962<sup>b</sup>  
 of Writing . . . . . 3114<sup>a</sup> (Richardson)
- Thaddaeus . . . . . 2964<sup>a</sup> (Kerr)  
 of Apocryphal Acts . . . 183<sup>b</sup> (A. F. Findlay)  
 of Judas . . . . . 1765<sup>a</sup> (S. F. Hunter)  
 of Judas, Not Iscariot . 1767<sup>a</sup>  
 of Judas of James . . . 1767<sup>b</sup> (Kerr)  
 of Lebbaeus . . . . . 1864<sup>a</sup>  
 of Simon the Cana-  
 naean . . . . . 2797<sup>b</sup> (Kerr)  
 of Thomas . . . . . 2973<sup>a</sup> (Kerr)
- Thahash  
 of Tahash . . . . . 2902<sup>b</sup>
- Thamah  
 of Temah . . . . . 2929<sup>a</sup>
- Thamar . . . . . 2964<sup>b</sup>  
 of Tamar (person) . . . 2907<sup>b</sup> (Orr)
- Thammuz  
 of Tammuz . . . . . 2908<sup>a</sup> (Porter)
- Thamnatha  
 of Timnah . . . . . 2983<sup>a</sup> (Masterman)
- Thank, Thanks, Thanks-  
 giving . . . . . 2964<sup>b</sup> (Easton)  
 of Grace . . . . . 1290<sup>a</sup> (Easton)
- Thank Offering  
 of Sacrifice in the OT . 2638<sup>a</sup> (Reeve)
- Thara . . . . . 2965<sup>a</sup>  
 of Terah (person) . . . 2948<sup>b</sup> (Easton)
- Tharra . . . . . 2965<sup>a</sup>
- Tharshish  
 of Tarshish . . . . . 2914<sup>a</sup>
- Thassi . . . . . 2965<sup>a</sup>  
 of Simon . . . . . 2794<sup>b</sup> (Angus)
- That Day  
 of Day of the Lord . . . 799<sup>a</sup> (Dosker)
- Theatre  
 of Games . . . . . 1168<sup>b</sup> (Smith)
- Thebes  
 of No-amon . . . . . 2153<sup>b</sup> (Kyle)
- Thebez . . . . . 2965<sup>a</sup> (Ewing)
- Thecoe  
 of Tekoa . . . . . 2924<sup>a</sup> (Masterman)
- Thee-ward . . . . . 2965<sup>a</sup>  
 of Ward . . . . . 3072<sup>a</sup> (Easton)
- Theft  
 of Crimes . . . . . 748<sup>a</sup> (Hirsch)  
 of Punishments . . . . . 2504<sup>b</sup> (Hirsch)  
 of Thief . . . . . 2972<sup>a</sup> (Easton)
- Thelasar  
 of Telassar . . . . . 2925<sup>a</sup> (Pinches)
- Thelersas . . . . . 2965<sup>b</sup>  
 of Tel-harsha . . . . . 2925<sup>a</sup>
- Theocanus . . . . . 2965<sup>b</sup>  
 of Thocanus . . . . . 2973<sup>a</sup>  
 of Tikvah . . . . . 2981<sup>b</sup>
- Theocracy . . . . . 2965<sup>b</sup> (McPheeters)  
 OT idea . . . . . 2965<sup>b</sup>  
 OT passages . . . . . 2965<sup>b</sup>  
 Origin of term . . . . . 2965<sup>b</sup>
- Theodotion  
 of Language of the NT . 1826<sup>b</sup> (A. T. Robertson)  
 of Septuagint . . . . . 2725<sup>b</sup> (Thackeray)
- Theodotus . . . . . 2966<sup>a</sup>
- Theology  
 of Biblical Theology . . 469<sup>b</sup> (J. Lindsay)  
 of Johannine Theology . 1695<sup>b</sup> (Law)  
 of Pauline Theology . . 2289<sup>a</sup> (Easton)
- Theophilus . . . . . 2966<sup>a</sup> (Kerr)
- Theras . . . . . 2966<sup>a</sup>
- Thermeleth . . . . . 2966<sup>a</sup>  
 of Tel-melah . . . . . 2928<sup>b</sup>
- Thessalonians, The First  
 Epistle of Paul to the . 2966<sup>a</sup> (R. H. Walker)  
 Analysis . . . . . 2967<sup>b</sup>  
 Conditions in the  
 church . . . . . 2967<sup>a</sup>  
 Doctrinal features . . . 2967<sup>b</sup>  
 Founding of the  
 church . . . . . 2966<sup>b</sup>  
 Importance . . . . . 2966<sup>a</sup>  
 Luke's narrative re-  
 garding the church . 2966<sup>b</sup>  
 Paul's characteristics  
 as revealed . . . . . 2967<sup>b</sup>
- Thessalonians, The Sec-  
 ond Epistle of Paul to  
 the . . . . . 2968<sup>a</sup> (R. H. Walker)  
 Against Pauline author-  
 ship . . . . . 2968<sup>a</sup>  
 Arguments for Pauline  
 authorship . . . . . 2968<sup>b</sup>  
 Authenticity . . . . . 2968<sup>a</sup>  
 Exhortation to indus-  
 try . . . . . 2970<sup>a</sup>  
 Importance of study-  
 ing 1 Thess and 2  
 Thess together . . . . . 2968<sup>a</sup>  
 Man of sin, the . . . . . 2969<sup>a</sup>  
 of Man of Sin . . . . . 1976<sup>b</sup> (Orr)  
 Theories regarding  
 man of sin . . . . . 2969<sup>a</sup>
- Thessalonica . . . . . 2970<sup>a</sup> (Tod)  
 History . . . . . 2970<sup>b</sup>  
 Later history of the  
 church in . . . . . 2971<sup>b</sup>  
 Paul's visit . . . . . 2970<sup>b</sup>  
 Position and name . . . 2970<sup>a</sup>  
 Thessalonian church . 2971<sup>a</sup>
- Theudas . . . . . 2972<sup>a</sup> (Kerr)  
 of Gamaliel . . . . . 1168<sup>a</sup> (Kerr)
- Thick Trees . . . . . 2972<sup>a</sup>  
 of Myrtle . . . . . 2103<sup>b</sup> (Masterman)
- Thicket . . . . . 2972<sup>a</sup>  
 of Forest . . . . . 1132<sup>a</sup> (Masterman)
- Thief . . . . . 2972<sup>a</sup> (Easton)  
 of Assassins . . . . . 288<sup>a</sup> (S. F. Hunter)  
 of Barabbas . . . . . 402<sup>a</sup> (Rees)

- Thief—*continued*  
 cf Crimes. . . . . 745<sup>b</sup> (Hirsch)  
 cf Robber, Robbery. . . . . 2595<sup>b</sup> (Easton)  
 Thigh . . . . . 2972<sup>b</sup> (Easton)  
 cf Hip . . . . . 1394<sup>b</sup>  
 cf Jealousy . . . . . 1572<sup>b</sup> (Forrester)  
 cf Knee . . . . . 1815<sup>a</sup> (Easton)  
 cf Leg . . . . . 1865<sup>a</sup> (Luering)  
 cf Loins . . . . . 1917<sup>a</sup> (Luering)  
 cf Sacrifice in NT. . . . . 2651<sup>a</sup> (Williams)  
 cf Sacrifice in OT. . . . . 2638<sup>a</sup> (Reeve)  
 Thimnathah . . . . . 2972<sup>b</sup>  
 cf Timnah . . . . . 2983<sup>a</sup> (Masterman)  
 Think . . . . . 2972<sup>b</sup> (Jacobs)  
 cf Thought . . . . . 2975<sup>a</sup>  
 Third . . . . . 2973<sup>a</sup>  
 cf Calendar . . . . . 541<sup>b</sup> (Porter)  
 cf Day . . . . . 797<sup>b</sup> (Gerberding)  
 cf Time . . . . . 2981<sup>b</sup> (Porter)  
 Third Day  
 cf Lord's Day . . . . . 1919<sup>a</sup> (Easton)  
 Thirst . . . . . 2973<sup>a</sup> (Orr)  
 Thirteen, Thirty  
 cf Number . . . . . 2157<sup>a</sup> (Smith)  
 Thisbe . . . . . 2973<sup>a</sup>  
 Thistles  
 cf Thorns, Thistles. . . . . 2974<sup>a</sup> (Masterman)  
 Thocanus . . . . . 2973<sup>a</sup>  
 cf Tikvah. . . . . 2981<sup>b</sup>  
 Thomas . . . . . 2973<sup>a</sup> (Kerr)  
 cf Apocryphal Gospels. 195<sup>a</sup> (Hutchison)  
 In apocryphal literature . . . . . 2973<sup>b</sup>  
 Character . . . . . 2973<sup>b</sup>  
 In NT . . . . . 2973<sup>a</sup>  
 cf Thaddaeus . . . . . 2964<sup>a</sup> (Kerr)  
 Thomas, Gospel of  
 cf Apocryphal Gospels. 195<sup>a</sup> (Hutchison)  
 Thomei . . . . . 2973<sup>b</sup>  
 cf Temah. . . . . 2929<sup>a</sup>  
 Thorn in the Flesh. . . . . 2974<sup>a</sup> (Macalister)  
 cf Thorns, Thistles. . . . . 2974<sup>a</sup> (Masterman)  
 Thorns, Thistles. . . . . 2974<sup>a</sup> (Masterman)  
 In Biblical history . . . . . 2975<sup>a</sup>  
 Biblical references . . . . . 2974<sup>a</sup>  
 cf Botany . . . . . 505<sup>a</sup> (Masterman)  
 cf Hook . . . . . 1419<sup>a</sup> (Easton)  
 Names for . . . . . 2974<sup>a</sup>  
 cf Nettles . . . . . 2140<sup>a</sup> (Masterman)  
 Plentifulness in Palestine . . . . . 2975<sup>a</sup>  
 Thought . . . . . 2975<sup>a</sup>  
 cf Think . . . . . 2972<sup>b</sup> (Jacobs)  
 Thousand  
 cf Number . . . . . 2157<sup>a</sup> (Smith)  
 Thracia, Thracian. . . . . 2975<sup>b</sup>  
 cf Tiras . . . . . 2986<sup>a</sup> (Wolf)  
 Thrasaeus . . . . . 2975<sup>b</sup>  
 cf Apollonius . . . . . 200<sup>b</sup> (Hutchison)  
 Three  
 cf Number . . . . . 2157<sup>a</sup> (Smith)
- Three Children, Song of  
 the . . . . . 2834<sup>a</sup> (T. W. Davies)  
 Threescore  
 cf Number . . . . . 2157<sup>a</sup> (Smith)  
 Threshing . . . . . 2975<sup>b</sup> (Patch)  
 cf Agriculture . . . . . 75<sup>b</sup> (Patch)  
 Threshing-floor. . . . . 2975<sup>b</sup> (Patch)  
 Threshold  
 cf House . . . . . 1434<sup>b</sup> (A. C. Dickie)  
 Throne . . . . . 2976<sup>a</sup> (Baur)  
 Biblical references . . . . . 2976<sup>b</sup>  
 cf King, Kingdom . . . . . 1799<sup>a</sup> (Press)  
 Majesty of . . . . . 2976<sup>a</sup>  
 Symbol of Divine power . . . . . 2977<sup>a</sup>  
 Thrum . . . . . 2977<sup>a</sup>  
 Thummim  
 cf Integrity . . . . . 1484<sup>a</sup> (W. L. Walker)  
 cf Urim and Thummim . . . . . 3040<sup>b</sup> (N. Isaacs)  
 Thunder . . . . . 2977<sup>a</sup> (Joy)  
 cf Lightning . . . . . 1892<sup>b</sup> (Joy)  
 Thyatira . . . . . 2977<sup>b</sup> (Banks)  
 History and products. . . . . 2977<sup>b</sup>  
 Location . . . . . 2977<sup>b</sup>  
 Present town. . . . . 2977<sup>b</sup>  
 Thyne Wood . . . . . 2978<sup>a</sup>  
 Tiberias . . . . . 2978<sup>a</sup> (Ewing)  
 History of . . . . . 2978<sup>b</sup>  
 Location . . . . . 2978<sup>a</sup>  
 Modern city . . . . . 2979<sup>a</sup>  
 Tiberias, Sea of  
 cf Galilee, Sea of . . . . . 1165<sup>a</sup> (Ewing)  
 Tiberius . . . . . 2979<sup>a</sup> (Angus)  
 Administration . . . . . 2979<sup>b</sup>  
 Character . . . . . 2979<sup>b</sup>  
 Early life and relations  
 to Augustus . . . . . 2979<sup>a</sup>  
 Jews, the, and . . . . . 2980<sup>a</sup>  
 Name and parentage . . . . . 2979<sup>a</sup>  
 NT and . . . . . 2979<sup>b</sup>  
 Reign . . . . . 2979<sup>b</sup>  
 Tibhath . . . . . 2980<sup>a</sup> (Christie)  
 Tibni . . . . . 2980<sup>a</sup>  
 Tiboam  
 cf Jerusalem . . . . . 1608<sup>a</sup> (Masterman)  
 Tidal . . . . . 2980<sup>a</sup> (Pinches)  
 cf Amraphel . . . . . 126<sup>a</sup> (Pinches); 366<sup>a</sup> (Clay)  
 cf Arioch . . . . . 241<sup>a</sup> (Pinches)  
 cf Chedorlaomer. . . . . 599<sup>a</sup> (Pinches)  
 cf Eri-aku . . . . . 969<sup>b</sup> (Pinches)  
 cf Hammurabi . . . . . 1326<sup>a</sup> (Pinches)  
 Name and its forms. . . . . 2980<sup>b</sup>  
 Suggestions . . . . . 2980<sup>b</sup>  
 Tudhula mentioned. . . . . 2980<sup>b</sup>  
 Tidings, Glad . . . . . 1233<sup>a</sup> (W. L. Walker)  
 Tigellihus  
 cf Nero . . . . . 2136<sup>a</sup> (Angus)  
 Tiglath-pileser . . . . . 2980<sup>b</sup> (Nicol); 294<sup>a</sup>  
 (Sayce)  
 History of . . . . . 2981<sup>a</sup>  
 Name and references. . . . . 2980<sup>b</sup>

- Tiglath-pileser—*continued*  
 cf Pul. . . . . 2501<sup>b</sup>  
 cf Syria. . . . . 2883<sup>a</sup> (Christie)  
 Western campaigns of 570<sup>b</sup> (Nicol)
- Tigris. . . . . 2981<sup>a</sup> (Wright)  
 cf Eden. . . . . 897<sup>b</sup> (Wright)
- Tikvah, Tikvath. . . . . 2981<sup>b</sup>  
 cf Theocanus. . . . . 2965<sup>b</sup>  
 cf Thocanus. . . . . 2973<sup>a</sup>
- Tile, Tiling. . . . . 2981<sup>b</sup>  
 cf Ezekiel. . . . . 1071<sup>a</sup> (Möller)  
 cf House. . . . . 1434<sup>b</sup> (A. C. Dickie)
- Tilgath-pilneser  
 cf Tiglath-pileser. . . . . 2980<sup>b</sup> (Nicol)
- Tillage  
 cf Agriculture. . . . . 75<sup>b</sup> (Patch)
- Tilon. . . . . 2981<sup>b</sup>
- Timæus. . . . . 2981<sup>b</sup>  
 cf Bartimæus. . . . . 406<sup>b</sup> (Rees)
- Timbrel  
 cf Music. . . . . 2094<sup>b</sup> (Millar)
- Time. . . . . 2981<sup>b</sup> (Porter)  
 cf Astronomy. . . . . 300<sup>b</sup> (Maunder)  
 cf Calendar. . . . . 541<sup>b</sup> (Porter)  
 cf Coins. . . . . 673<sup>a</sup> (Porter)  
 cf Day. . . . . 797<sup>b</sup> (Gerberding)  
 cf Era. . . . . 968<sup>b</sup> (Porter)  
 Hebrew divisions. . . . . 2982<sup>b</sup>  
 cf Hour. . . . . 1434<sup>a</sup> (Porter)  
 cf Midnight. . . . . 2050<sup>a</sup> (Porter)  
 cf Money. . . . . 2076<sup>a</sup> (Porter)  
 cf Month. . . . . 2081<sup>a</sup> (Porter)  
 cf Night-watch. . . . . 2145<sup>a</sup>  
 No era. . . . . 2982<sup>b</sup>  
 cf Noon, Noonday. . . . . 2155<sup>a</sup>  
 cf Third. . . . . 2973<sup>a</sup>  
 cf Watch. . . . . 3074<sup>a</sup> (Porter)  
 cf Week. . . . . 3078<sup>b</sup>  
 Week and month. . . . . 2982<sup>a</sup>  
 cf Year. . . . . 3126<sup>a</sup>  
 Year and seasons. . . . . 2982<sup>a</sup>
- Time, Last. . . . . 1840<sup>a</sup> (Vos)
- Time, Times and a Half. 2982<sup>b</sup>  
 cf Astronomy. . . . . 300<sup>b</sup> (Maunder)
- Times, Observer of  
 cf Divination. . . . . 860<sup>a</sup> (T. W. Davies)  
 cf Magic. . . . . 1963<sup>a</sup> (T. W. Davies)
- Timna. . . . . 2983<sup>a</sup>
- Timnah. . . . . 2983<sup>a</sup> (Masterman)
- Timnath  
 cf Timnah. . . . . 2983<sup>a</sup> (Masterman)
- Timnath-heres. . . . . 2983<sup>a</sup> (Ewing)
- Timnath-serah. . . . . 2983<sup>a</sup> (Ewing)  
 cf Gaash. . . . . 1150<sup>a</sup>
- Timnite. . . . . 2983<sup>b</sup>
- Timon. . . . . 2983<sup>b</sup>
- Timotheus. . . . . 2983<sup>b</sup> (Angus)
- Timothy. . . . . 2983<sup>b</sup> (Rutherford)  
 Birth and conversion. . . . . 2984<sup>a</sup>  
 Circumcision and ordination. . . . . 2984<sup>a</sup>  
 Father and mother. . . . . 2984<sup>a</sup>
- Timothy—*continued*  
 cf Lois. . . . . 1917<sup>b</sup> (Rutherford)  
 NT references to. . . . . 2984<sup>b</sup>  
 Relations to Ephesus. . . . . 2985<sup>a</sup>  
 Relations with Paul. . . . . 2984<sup>a</sup>  
 Rome, at. . . . . 2985<sup>b</sup>  
 cf Titus. . . . . 2988<sup>b</sup> (Rutherford)
- Timothy, Epistles to  
 cf Pastoral Epistles. . . . . 2258<sup>b</sup> (Rutherford)
- Tin. . . . . 2985<sup>b</sup>  
 cf Alloy. . . . . 99<sup>b</sup>
- Tiphshah. . . . . 2985<sup>b</sup> (Ewing)
- Tiras. . . . . 2986<sup>a</sup> (Wolf)  
 cf Thracia, Thracian. . . . . 2975<sup>b</sup>
- Tirathites. . . . . 2986<sup>a</sup> (Wolf)
- Tire, Headtire. . . . . 2986<sup>a</sup>  
 cf Dress. . . . . 875<sup>b</sup> (Eager)
- Tires, Round. . . . . 2986<sup>a</sup>  
 cf Astronomy. . . . . 300<sup>b</sup> (Maunder)  
 cf Crescents. . . . . 744<sup>b</sup>
- Tirhakah. . . . . 2986<sup>a</sup> (Pinches)  
 Chronology. . . . . 2986<sup>b</sup>  
 Name and dynasty. . . . . 2986<sup>a</sup>  
 Relations with Assyria. . . . . 2986<sup>b</sup>
- Tirhana. . . . . 2986<sup>b</sup>
- Tiria. . . . . 2986<sup>b</sup>
- Tirshatha. . . . . 2986<sup>b</sup> (R. D. Wilson)  
 cf Governor. . . . . 1289<sup>b</sup> (Heidel)  
 cf Zerubbabel. . . . . 3147<sup>b</sup> (R. D. Wilson)
- Tirzah. . . . . 2987<sup>a</sup> (Ewing)
- Tishbite. . . . . 2987<sup>a</sup>  
 cf Elijah. . . . . 930<sup>b</sup> (Farr)
- Tishri, Tisri. . . . . 2987<sup>a</sup>  
 cf Calendar. . . . . 541<sup>b</sup> (Porter)
- Titans. . . . . 2987<sup>a</sup>  
 cf Rephaim. . . . . 2559<sup>b</sup> (Porter)
- Tithe. . . . . 2987<sup>b</sup> (Levertoff)  
 cf First-fruits. . . . . 1114<sup>a</sup> (Levertoff)  
 OT references. . . . . 2987<sup>b</sup>  
 cf Priests and Levites. . . . . 2446<sup>b</sup> (Wiener)  
 Relation of priests to. . . . . 2987<sup>b</sup>  
 Variations in laws. . . . . 2988<sup>a</sup>
- Titius Justus  
 cf Justus. . . . . 1788<sup>b</sup> (S. F. Hunter)  
 cf Titus or Titius Justus. . . . . 2989<sup>b</sup> (Rutherford)
- Title. . . . . 2988<sup>b</sup>  
 cf Superscription. . . . . 2871<sup>a</sup> (Miller)
- Tittle. . . . . 2988<sup>b</sup>  
 cf Jot. . . . . 1753<sup>b</sup> (Easton)  
 cf Yodh. . . . . 3126<sup>a</sup>
- Titus. . . . . 2988<sup>b</sup> (Rutherford)  
 Character. . . . . 2989<sup>b</sup>  
 Circumcised. . . . . 2988<sup>b</sup>  
 Journeys. . . . . 2989<sup>a</sup>  
 Relations with Paul. . . . . 2988<sup>b</sup>  
 cf Timothy. . . . . 2984<sup>a</sup> (Rutherford)
- Titus, Epistle to  
 cf Pastoral Epistles. . . . . 2258<sup>b</sup> (Rutherford)
- Titus, or Titius Justus. . . . . 2989<sup>b</sup> (Rutherford)  
 cf Justus. . . . . 1788<sup>b</sup> (S. F. Hunter)  
 cf Proselyte. . . . . 2467<sup>b</sup> (Levertoff)

- Titus Manius . . . . . 1982<sup>a</sup> (Angus)  
 Tizite . . . . . 2990<sup>a</sup>  
 Toah  
   cf Nahath . . . . . 2109<sup>b</sup>  
 Tob, The Land of . . . . . 2990<sup>a</sup> (Ewing)  
   cf Tubias . . . . . 3027<sup>b</sup>  
 Tob-adonijah . . . . . 2990<sup>a</sup>  
 Tobiah . . . . . 2990<sup>a</sup> (R. D. Wilson)  
 Tobias . . . . . 2990<sup>b</sup>  
   cf Hyrcanus . . . . . 1445<sup>b</sup>  
   cf Tobit, Book of . . . . . 2990<sup>b</sup> (T. W. Davies)  
 Tobie  
   cf Tubias . . . . . 3027<sup>b</sup>  
 Tobiel . . . . . 2990<sup>b</sup>  
   cf Tabeel . . . . . 2887<sup>b</sup> (Eiselen)  
 Tobijah . . . . . 2990<sup>b</sup>  
   cf Tebaliah . . . . . 2924<sup>a</sup>  
 Tobit, Book of . . . . . 2990<sup>b</sup> (T. W. Davies)  
   cf Apocrypha . . . . . 178<sup>b</sup> (T. W. Davies)  
   Contents . . . . . 2990<sup>b</sup>  
   Date . . . . . 2992<sup>a</sup>  
   Fact or fiction? . . . . . 2991<sup>a</sup>  
   Name and canonicity . . . . . 2990<sup>b</sup>  
   Original language . . . . . 2993<sup>a</sup>  
   Place of composition . . . . . 2992<sup>b</sup>  
   Relation to Esther . . . . . 2992<sup>a</sup>  
   cf Sarah . . . . . 2691<sup>b</sup> (Boyd)  
   Sources . . . . . 2991<sup>b</sup>  
   cf Tobias . . . . . 2990<sup>b</sup>  
   Versions . . . . . 2992<sup>b</sup>  
 Tochen . . . . . 2993<sup>b</sup>  
 Togarmah . . . . . 2993<sup>b</sup> (Pinches)  
   cf Armenia . . . . . 246<sup>b</sup> (Tisdall)  
   cf Table of Nations . . . . . 2898<sup>b</sup> (Pinches)  
   cf Trade . . . . . 3003<sup>a</sup> (Easton)  
 Tohu  
   cf Nahath . . . . . 2109<sup>b</sup>  
 Toi  
   cf Tou . . . . . 3000<sup>b</sup>  
 Token . . . . . 2994<sup>a</sup> (Easton)  
   cf Sign . . . . . 2789<sup>a</sup> (Stuart)  
 Tokhath  
   cf Tikvah . . . . . 2981<sup>b</sup>  
 Tola . . . . . 2994<sup>a</sup> (E. D. Isaacs)  
 Tolad  
   cf Eltolad . . . . . 939<sup>b</sup>  
 Tolaites  
   cf Tola . . . . . 2994<sup>a</sup> (E. D. Isaacs)  
 Tolbanes . . . . . 2994<sup>a</sup>  
   cf Telem (person) . . . . . 2925<sup>b</sup>  
 Toll . . . . . 2994<sup>a</sup> (Pollard)  
 Tomb  
   cf Burial . . . . . 530<sup>b</sup> (Eager)  
   cf Seal . . . . . 2709<sup>a</sup> (Edwards)  
 Tomorrow  
   cf Morrow . . . . . 2083<sup>a</sup> (Porter)  
 Tongs . . . . . 2994<sup>a</sup>  
   cf Snuffers, Snuffdishes 2820<sup>a</sup> (Caldecott)  
   cf Tools . . . . . 2999<sup>a</sup> (Easton)  
 Tongue . . . . . 2994<sup>b</sup> (Easton)  
   cf Mouth . . . . . 2093<sup>a</sup> (Luering)
- Tongue—*continued*  
   cf Tongues, Confusion  
     of . . . . . 2994<sup>b</sup> (Easton)  
 Tongues, Confusion of . . . . . 2994<sup>b</sup> (Easton)  
   cf Babel, Tower of . . . . . 355<sup>b</sup> (Pinches)  
   Context . . . . . 2995<sup>a</sup>  
   Historicity . . . . . 2995<sup>a</sup>  
   Narrative, the . . . . . 2994<sup>b</sup>  
   Religious value . . . . . 2995<sup>b</sup>  
   Sources . . . . . 2995<sup>b</sup>  
   cf Tongue . . . . . 2994<sup>b</sup> (Easton)  
 Tongues of Fire . . . . . 2997<sup>a</sup> (Moorehead)  
   Distinctions . . . . . 2998<sup>a</sup>  
   Pentecost scene . . . . . 2997<sup>b</sup>  
   Qualities imparted by  
     the Spirit . . . . . 2998<sup>a</sup>  
   Sinai and Pentecost  
     compared . . . . . 2997<sup>b</sup>  
   cf Tongues, Gift of . . . . . 2995<sup>b</sup> (Easton)  
 Tongues, Gift of . . . . . 2995<sup>b</sup> (Easton)  
   Account in Acts 2 . . . . . 2996<sup>b</sup>  
   Description in 1 Cor  
     14 . . . . . 2996<sup>a</sup>  
   Ecstasy, state of . . . . . 2996<sup>a</sup>  
   Foreign languages  
     barred out . . . . . 2996<sup>a</sup>  
   cf Holy Spirit . . . . . 1406<sup>a</sup> (Mullins)  
   cf Mystery . . . . . 2104<sup>a</sup> (Edwards)  
   Religious emotionalism 2997<sup>a</sup>  
   cf Spiritual Gifts . . . . . 2843<sup>a</sup> (Lambert)  
   cf Tongues of Fire . . . . . 2997<sup>a</sup> (Moorehead)  
   cf Worship . . . . . 3112<sup>a</sup> (Crannell)  
 Tongues, Interpretation of  
   cf Spiritual Gifts . . . . . 2843<sup>a</sup> (Lambert)  
   cf Tongues, Gift of . . . . . 2995<sup>b</sup> (Easton)  
 Tools . . . . . 2998<sup>b</sup> (Easton)  
   cf Agriculture . . . . . 75<sup>b</sup> (Patch)  
   cf Ax, Ax-head . . . . . 341<sup>a</sup> (Patch)  
   cf Awl . . . . . 341<sup>a</sup>  
   cf Carpenter . . . . . 580<sup>a</sup>  
   cf Compasses . . . . . 694<sup>b</sup> (W. L. Walker)  
   cf Crafts . . . . . 734<sup>a</sup> (Patch)  
   Cutting tools . . . . . 2998<sup>b</sup>  
   cf File . . . . . 1110<sup>a</sup>  
   Hammer . . . . . 2998<sup>b</sup>  
     cf Hammer . . . . . 1325<sup>b</sup> (Patch)  
   cf Hatchet . . . . . 1343<sup>b</sup>  
   cf Knife . . . . . 1815<sup>b</sup> (Pollard)  
   cf Line . . . . . 1894<sup>a</sup> (Orr)  
   cf Mattock . . . . . 2012<sup>b</sup>  
   Other tools . . . . . 2999<sup>a</sup>  
   cf Pencil . . . . . 2298<sup>a</sup>  
   cf Potter . . . . . 2423<sup>b</sup> (Patch)  
   cf Reed . . . . . 2544<sup>a</sup> (Masterman)  
   cf Tongs . . . . . 2994<sup>a</sup>  
 Toparchy . . . . . 2999<sup>a</sup>  
 Topaz  
   cf Stones, Precious . . . . . 2862<sup>b</sup> (Fletcher)  
 Tophel . . . . . 2999<sup>a</sup> (Ewing)  
 Topheth . . . . . 2999<sup>b</sup> (Masterman)  
   cf Hinnom, Valley of . . . . . 1393<sup>b</sup> (Masterman)  
   cf Kidron, The Brook . . . . . 1798<sup>a</sup> (Masterman)

- Topheth—*continued*  
 cf Pile . . . . . 2398<sup>b</sup>
- Torah  
 cf Law in the OT . . . . . 1852<sup>a</sup> (Rule)  
 cf Revelation . . . . . 2573<sup>b</sup> (Warfield)
- Torch . . . . . 2999<sup>b</sup>  
 cf Lamp . . . . . 1825<sup>a</sup> (Porter)  
 cf Lantern . . . . . 1836<sup>b</sup>
- Tormah . . . . . 2999<sup>b</sup>  
 cf Privy . . . . . 2457<sup>a</sup>
- Torment, Place of . . . . . 2999<sup>b</sup>  
 cf Hell . . . . . 1371<sup>a</sup> (Orr)
- Tormentor . . . . . 2999<sup>b</sup> (Easton)
- Tortoise . . . . . 2999<sup>b</sup> (Day)  
 cf Lizard . . . . . 1906<sup>a</sup> (Day)  
 cf Reptile . . . . . 2561<sup>a</sup>
- Torture  
 cf Siege . . . . . 2788<sup>b</sup> (Nicol)
- Totemism . . . . . 3000<sup>a</sup> (M. O. Evans)  
 Animal names . . . . . 3000<sup>a</sup>  
 Criticism . . . . . 3000<sup>a</sup>  
 cf Defilement . . . . . 818<sup>a</sup> (Crannell)  
 cf Images . . . . . 1453<sup>a</sup> (Cobern)  
 In Israel . . . . . 3000<sup>a</sup>  
 cf Israel, Religion of . . . . . 1532<sup>a</sup> (Orelli)  
 cf Sacrifice (NT) . . . . . 2651<sup>a</sup> (Williams)  
 cf Sacrifice (OT) . . . . . 2638<sup>a</sup> (Reeve)  
 cf Shaphan . . . . . 2749<sup>b</sup> (Wolf)  
 cf Wolf . . . . . 3099<sup>b</sup> (Day)  
 cf Zimran . . . . . 3149<sup>b</sup> (Roberts)
- Tou . . . . . 3000<sup>b</sup>
- Tow . . . . . 3000<sup>b</sup>
- Tower  
 cf City . . . . . 662<sup>a</sup> (A. C. Dickie)  
 cf Fortification . . . . . 1137<sup>b</sup> (Nicol)  
 cf Watch-tower . . . . . 3074<sup>a</sup>
- Tower of Babel  
 cf Astronomy . . . . . 300<sup>b</sup> (Maunder)  
 cf Babel, Tower of . . . . . 355<sup>b</sup> (Pinches)  
 cf Tongues, Confusion  
 of . . . . . 2994<sup>b</sup> (Easton)
- Tower of David  
 cf Jerusalem . . . . . 1595<sup>b</sup> (Masterman)
- Tower of Edar (The  
 Flock)  
 cf Eder . . . . . 899<sup>a</sup> (Masterman)
- Tower of the Furnaces . . . . . 1149<sup>b</sup>
- Tower of Hananeel  
 cf Hananel, Tower of . . . . . 1333<sup>a</sup> (Masterman)
- Tower of Ivory . . . . . 3000<sup>b</sup> (Christie)
- Tower of Lebanon . . . . . 3000<sup>b</sup> (Christie)  
 cf Lebanon . . . . . 1862<sup>b</sup> (Wright)
- Tower of Meah  
 cf Hammeah, Tower of . . . . . 1325<sup>b</sup> (Masterman)
- Tower of Penuel  
 cf Peniel . . . . . 2298<sup>a</sup> (Ewing)
- Tower of Shechem . . . . . 3000<sup>b</sup>
- Tower of Siloam  
 cf Siloam . . . . . 2791<sup>a</sup> (Masterman)
- Tower of Syene  
 cf Seveh . . . . . 2744<sup>a</sup>
- Town . . . . . 3001<sup>a</sup> (Christie)  
 cf City . . . . . 662<sup>a</sup> (A. C. Dickie)  
 cf Havvoth-jair . . . . . 1345<sup>a</sup> (Ewing)  
 cf Village . . . . . 3049<sup>b</sup> (Christie)
- Town Clerk . . . . . 3001<sup>a</sup> (Dosker)  
 cf Ephesus . . . . . 961<sup>a</sup> (Banks)
- Trachonitis . . . . . 3001<sup>a</sup> (Ewing)  
 cf Argob . . . . . 240<sup>b</sup> (Ewing)  
 Description . . . . . 3001<sup>b</sup>  
 Location . . . . . 3001<sup>a</sup>  
 Present condition . . . . . 3001<sup>b</sup>
- Trade . . . . . 3002<sup>a</sup> (Easton)  
 cf Alexandria . . . . . 93<sup>a</sup> (Cobern)  
 cf Antioch . . . . . 157<sup>b</sup> (C. H. Thomson)  
 cf Chapman . . . . . 594<sup>b</sup>  
 Early history of . . . . . 3002<sup>b</sup>  
 cf Ethics . . . . . 1013<sup>a</sup> (Alexander)  
 Exilic and later . . . . . 3003<sup>b</sup>  
 cf Exile . . . . . 1052<sup>a</sup>  
 Maritime trade . . . . . 3003<sup>a</sup>  
 Position of Palestine . . . . . 3002<sup>b</sup>  
 Preëxilic . . . . . 3003<sup>b</sup>  
 Products of Palestine . . . . . 3002<sup>b</sup>  
 cf Ships and Boats . . . . . 2774<sup>a</sup> (Nicol)  
 Solomon . . . . . 3003<sup>a</sup>  
 Terms for . . . . . 3002<sup>a</sup>  
 cf Togarmah . . . . . 2993<sup>b</sup> (Pinches)  
 cf Traffic . . . . . 3004<sup>b</sup> (Raffety)  
 cf Wine . . . . . 3088<sup>a</sup> (Easton)
- Trades  
 cf Crafts . . . . . 734<sup>a</sup> (Patch)
- Tradition . . . . . 3004<sup>a</sup> (Williams)  
 cf Heredity . . . . . 1376<sup>a</sup> (Easton)  
 In Jewish theology . . . . . 3004<sup>a</sup>  
 In Pauline writings . . . . . 3004<sup>b</sup>  
 cf Sin . . . . . 2798<sup>b</sup> (McConnell)  
 cf Uncleanness . . . . . 3036<sup>b</sup> (Williams)
- Traffic, Trafficker . . . . . 3004<sup>b</sup> (Raffety)  
 cf Canaan . . . . . 549<sup>a</sup> (Sayce)  
 cf Market . . . . . 1995<sup>b</sup> (Raffety)  
 cf Merchandise . . . . . 2035<sup>a</sup> (Raffety)  
 cf Ships and Boats . . . . . 2774<sup>a</sup> (Nicol)  
 cf Trade . . . . . 3002<sup>a</sup> (Easton)
- Tragacanth . . . . . 3005<sup>a</sup>  
 cf Spice . . . . . 2840<sup>a</sup> (Masterman)  
 cf Stacte . . . . . 2847<sup>b</sup>
- Train (noun) . . . . . 3005<sup>a</sup>  
 cf Skirt . . . . . 2814<sup>b</sup>
- Train, Trained . . . . . 3005<sup>a</sup>
- Trance . . . . . 3005<sup>a</sup> (Macalister)
- Transfiguration . . . . . 3005<sup>b</sup> (Stuart)  
 cf Jesus Christ . . . . . 1649<sup>a</sup> (Orr)  
 cf Naphtali . . . . . 2118<sup>b</sup> (Ewing)  
 Narrative of . . . . . 3005<sup>b</sup>  
 Significance of . . . . . 3005<sup>b</sup>
- Transfiguration, Mount  
 of . . . . . 3006<sup>a</sup> (Ewing)  
 cf Caesarea . . . . . 536<sup>b</sup> (Ewing)  
 Jebel Jermuk . . . . . 3006<sup>b</sup>  
 Mt. Hermon . . . . . 3006<sup>a</sup>  
 Not Olivet or Tabor . . . . . 3006<sup>a</sup>  
 cf Tabor, Mount of . . . . . 2901<sup>a</sup> (Ewing)



- Transform . . . . . 3006<sup>b</sup>  
 Transgression . . . . . 3006<sup>b</sup> (Dungan)  
 Translation . . . . . 3007<sup>a</sup> (McPheeters)  
 Trap . . . . . 3007<sup>a</sup> (Stratton-Porter)  
   cf Gin . . . . . 1231<sup>b</sup> (Stratton-Porter)  
   cf Snare . . . . . 2819<sup>a</sup> (Stratton-Porter)  
 Travail . . . . . 3007<sup>a</sup> (Macalister)  
   cf Birth . . . . . 477<sup>b</sup> (Eager)  
   cf Labor . . . . . 1819<sup>b</sup> (Orr)  
 Traveller . . . . . 3007<sup>b</sup>  
   cf Wayfaring Man . . . . . 3076<sup>a</sup>  
 Travels in Palestine  
   cf Palestine, Recent  
     Exploration . . . . . 2223<sup>b</sup> (Cobern)  
 Traverner, Richard . . . . . 948<sup>b</sup> (Hutchison)  
 Tread  
   cf Wine, Wine Press . . . . . 3086<sup>a</sup> (Easton)  
 Treason . . . . . 3007<sup>b</sup>  
 Treasure, Treasurer,  
   Treasury . . . . . 3007<sup>b</sup> (Raffety)  
   cf Corban . . . . . 709<sup>b</sup> (Baur)  
   Hidden riches . . . . . 3007<sup>b</sup>  
   NT references . . . . . 3008<sup>a</sup>  
   OT references . . . . . 3007<sup>b</sup>  
   cf Riches . . . . . 2590<sup>b</sup> (Forrester)  
   Storehouse . . . . . 3007<sup>b</sup>  
   cf Temple . . . . . 2938<sup>a</sup> (Caldecott; Orr)  
 Treasury (of Temple) . . . . . 3008<sup>b</sup> (Caldecott)  
   Later temples . . . . . 3008<sup>b</sup>  
   Origin of . . . . . 3008<sup>a</sup>  
   In Solomonian temple . . . . . 3008<sup>b</sup>  
   cf Temple . . . . . 2938<sup>a</sup> (Caldecott; Orr)  
 Treaty . . . . . 3008<sup>b</sup> (Nicol)  
   cf Rome . . . . . 2618<sup>a</sup> (Allen)  
   cf War . . . . . 3069<sup>b</sup> (Nicol)  
 Tree  
   cf Botany . . . . . 505<sup>a</sup> (Masterman)  
   cf Food . . . . . 1122<sup>b</sup> (Eager)  
   cf Siege . . . . . 2786<sup>b</sup> (Nicol)  
 Tree of Life . . . . . 3009<sup>a</sup> (Reeve)  
   In apocryphal writings . . . . . 3009<sup>b</sup>  
   In Eden . . . . . 3009<sup>a</sup>  
   Interpretation of Eden  
     story . . . . . 3009<sup>a</sup>  
   cf Life . . . . . 1888<sup>a</sup> (Reeve)  
   Poetic simile . . . . . 3009<sup>b</sup>  
   In Revelation of John . . . . . 3009<sup>b</sup>  
 Trees, Goodly . . . . . 1278<sup>b</sup> (Masterman)  
 Trees, Shady  
   cf Lotus Trees . . . . . 1931<sup>b</sup> (Masterman)  
 Trees, Thick . . . . . 2972<sup>a</sup>  
 Trench  
   cf Siege . . . . . 2786<sup>a</sup> (Nicol)  
 Trespass . . . . . 3010<sup>a</sup> (Dungan)  
 Trespass Offering  
   cf Sacrifice in the OT . . . . . 2638<sup>a</sup> (Reeve)  
 Trial  
   cf Courts, Judicial . . . . . 725<sup>b</sup> (Hirsch)  
   cf Sanhedrin . . . . . 2688<sup>b</sup> (Levertoff)  
 Trial of Jesus  
   cf Jesus, Arrest and  
     Trial of . . . . . 1668<sup>b</sup> (Maclaren)
- Tribe . . . . . 3010<sup>a</sup> (Easton)  
   cf Palestine . . . . . 2212<sup>b</sup> (Conder)  
 Tribulation . . . . . 3010<sup>b</sup> (Pollard)  
 Tribute . . . . . 3010<sup>b</sup> (Hirsch)  
   cf Tax, Taxing . . . . . 2918<sup>a</sup> (Sweet)  
 Tribute Money . . . . . 3011<sup>a</sup>  
 Triclinium . . . . . 3011<sup>a</sup> (N. Isaacs)  
   cf Feasts and Fasts . . . . . 1103<sup>a</sup> (E. D. Isaacs)  
 Trim . . . . . 3011<sup>a</sup>  
 Trine (Triune) Immer-  
   sion . . . . . 3011<sup>b</sup> (Kurtz)  
   cf Baptism . . . . . 385<sup>b</sup> (A. T. Robertson; T.  
     M. Lindsay; Dau)  
 Church fathers, the . . . . . 3012<sup>a</sup>  
 Doctrinal argument . . . . . 3011<sup>b</sup>  
 Greek church usage . . . . . 3012<sup>a</sup>  
 Historical practice . . . . . 3011<sup>b</sup>  
 Jesus and early Chris-  
   tians . . . . . 3011<sup>b</sup>  
 Linguistic basis . . . . . 3011<sup>b</sup>  
 cf Literature, Sub-apos. 1899<sup>a</sup> (Cowan)  
 Trinity . . . . . 3012<sup>a</sup> (Warfield)  
   cf Baptism . . . . . 385<sup>b</sup> (A. T. Robertson; T.  
     M. Lindsay; Dau)  
 Baptismal formula . . . . . 3017<sup>a</sup>  
 Baptismal formula,  
   criticism of . . . . . 3018<sup>a</sup>  
 Christian conscious-  
   ness . . . . . 3021<sup>a</sup>  
   cf Father, God the . . . . . 1100<sup>b</sup> (Orr)  
 Foundation of the doc-  
   trine . . . . . 3021<sup>b</sup>  
   cf God . . . . . 1250<sup>a</sup> (Rees)  
   Hints of, in OT . . . . . 3014<sup>b</sup>  
   Implications of the  
     "Son" and "Spirit" . . . . . 3020<sup>a</sup>  
   Implied in NT . . . . . 3015<sup>b</sup>  
   In Johannine dis-  
     courses . . . . . 3016<sup>b</sup>  
   Manifested in Son and  
     Spirit . . . . . 3015<sup>a</sup>  
   No rational proof of . . . . . 3013<sup>a</sup>  
   Not mentioned in OT . . . . . 3014<sup>a</sup>  
   In other NT writings . . . . . 3019<sup>b</sup>  
   In Pauline writings . . . . . 3018<sup>b</sup>  
     cf Pauline Theology 2290<sup>b</sup> (Easton)  
   Presupposed in NT . . . . . 3014<sup>b</sup>  
   A revealed doctrine . . . . . 3012<sup>b</sup>  
   Question of subordi-  
     nation . . . . . 3020<sup>b</sup>  
   Supported by reason . . . . . 3013<sup>b</sup>  
   In teaching of Jesus . . . . . 3016<sup>a</sup>  
   Term, the . . . . . 3012<sup>a</sup>  
   Triads of gods . . . . . 3012<sup>b</sup>  
   Variations in nomen-  
     clature . . . . . 3019<sup>b</sup>  
   Various arguments for 3013<sup>a</sup>  
 Tripolis (Apoc) . . . . . 3022<sup>b</sup> (Ewing)  
 Triumph . . . . . 3022<sup>b</sup> (A. W. Evans)  
   cf Josephus Flavius . . . . . 1742<sup>a</sup> (Wenley)  
   cf Savor . . . . . 2700<sup>b</sup> (Edwards)  
 Troas . . . . . 3023<sup>a</sup> (Banks)

- Troglodytes  
 of Palestine, Recent  
 Exploration.....2232<sup>a</sup> (Cobern)  
 Trogyllium.....3023<sup>a</sup> (Banks)  
 Troop  
 of Army.....254<sup>b</sup> (Nicol)  
 Trophimus.....3023<sup>b</sup> (Rutherford)  
 Cause of Paul's arrest.3023<sup>b</sup>  
 Description of.....3024<sup>a</sup>  
 An Ephesian.....3023<sup>b</sup>  
 At Miletus.....3023<sup>b</sup>  
 Trough  
 of Bread.....514<sup>b</sup> (Eager)  
 Trow.....3024<sup>a</sup>  
 Troy, Archaeological Evi-  
 dence of.....280<sup>a</sup> (White)  
 Trucebreaker.....3024<sup>a</sup>  
 Trump, Trumpet  
 of Music.....2094<sup>b</sup> (Millar)  
 Trumpets, Feast of.....3024<sup>a</sup> (Easton)  
 Description.....3024<sup>a</sup>  
 Later history.....3024<sup>b</sup>  
 Origin.....3024<sup>b</sup>  
 Ritual.....3024<sup>b</sup>  
 Significance.....3024<sup>b</sup>  
 Trust, Breach of.....3025<sup>a</sup>  
 Truth.....3025<sup>a</sup> (Carver)  
 Aspects of.....3025<sup>b</sup>  
 of Authority (in Reli-  
 gion).....333<sup>a</sup> (Rees)  
 of Ethics.....1013<sup>a</sup> (Alexander)  
 of Faithfulness.....1088<sup>b</sup> (Hodge)  
 In God.....3026<sup>a</sup>  
 In man.....3026<sup>b</sup>  
 of Philosophy.....2383<sup>a</sup> (Rees)  
 In religion.....3026<sup>b</sup>  
 of Right.....2591<sup>a</sup> (W. L. Walker)  
 of Sin.....2798<sup>b</sup> (McConnell)  
 Special features.....3026<sup>a</sup>  
 Standards of.....3025<sup>b</sup>  
 Terms.....3025<sup>a</sup>  
 Tryphaena.....3027<sup>a</sup> (S. F. Hunter)  
 Trypho  
 of Literature, Sub-apos 1904<sup>a</sup> (Cowan)  
 Tryphon.....3027<sup>a</sup> (Angus)  
 of Antiochus VI.....159<sup>b</sup> (Harry)  
 of Demetrius.....826<sup>a</sup> (Kinsella)  
 of Maccabaeus, Maccabees.....1947<sup>a</sup> (Hutchison)  
 Tryphosa.....3027<sup>a</sup>  
 of Tryphaena.....3027<sup>a</sup> (S. F. Hunter)  
 Tsadhe  
 of Qadhe.....536<sup>a</sup>  
 Tubal.....3027<sup>b</sup> (Wolf)  
 Tubal-cain.....3027<sup>b</sup> (Wolf)  
 Tubias.....3027<sup>b</sup>  
 of Tob, The Land of.....2990<sup>a</sup> (Ewing)  
 Tubieni.....3027<sup>b</sup>  
 Tumor.....3027<sup>b</sup>  
 of Emerods.....940<sup>b</sup> (Macalister)  
 Turanian Armenians.....247<sup>b</sup>  
 Turban  
 of Dress.....875<sup>b</sup> (Eager)  
 Turpentine Tree  
 of Terebinth.....2949<sup>a</sup> (Masterman)  
 Turtle-dove  
 of Dove.....872<sup>a</sup> (Stratton-Porter)  
 Tutor.....3028<sup>a</sup>  
 of Schoolmaster.....2702<sup>b</sup> (Easton)  
 Twelve  
 of Apostles.....202<sup>b</sup> (Lambert)  
 of Number.....2157<sup>a</sup> (Smith)  
 Twelve Apostles, Gospels  
 of the.....198<sup>a</sup> (Hutchison)  
 Twelve Patriarchs, Testa-  
 ments of the  
 of Apocalyptic Litera-  
 ture.....161<sup>b</sup> (J. E. H. Thomson)  
 Twelve Stars  
 of Astronomy.....300<sup>b</sup> (Maunder)  
 Twenty  
 of Number.....2157<sup>a</sup> (Smith)  
 Twilight.....3028<sup>a</sup> (Joy)  
 Twin Brothers  
 of Dioscuri.....851<sup>a</sup> (Maunder)  
 Twine.....3028<sup>a</sup>  
 of Linen.....1894<sup>a</sup> (E. D. Isaacs)  
 Two  
 of Number.....2157<sup>a</sup> (Smith)  
 Tychicus.....3028<sup>a</sup> (Rutherford)  
 Character and career.3028<sup>b</sup>  
 of Laodiceans, Epistle  
 to the.....1836<sup>b</sup> (Rutherford)  
 NT references.....3028<sup>a</sup>  
 Paul's relations with.3028<sup>b</sup>  
 Type.....3029<sup>a</sup> (Moorehead)  
 Classification of types.3029<sup>b</sup>  
 Definition.....3029<sup>a</sup>  
 Distinctive features of  
 types.....3029<sup>b</sup>  
 In OT.....3029<sup>b</sup>  
 Tyrannus.....3030<sup>a</sup> (S. F. Hunter)  
 Tyre.....3030<sup>b</sup> (Porter)  
 History.....3031<sup>a</sup>  
 of Phoenicia.....2391<sup>a</sup> (Porter)  
 Physical features.....3030<sup>b</sup>  
 of Ships and Boats.....2775<sup>b</sup> (Nicol)  
 of Sidon.....2785<sup>a</sup> (Porter)  
 of Siege.....2787<sup>a</sup> (Nicol)  
 Subjection to Sidon,  
 Egypt, etc.....3031<sup>a</sup>  
 Tyre, Ladder of.....3032<sup>b</sup> (Christie)  
 Tyropoeon, The  
 of Jerusalem.....1599<sup>b</sup> (Masterman)  
 Tyrus  
 of Tyre.....3030<sup>b</sup> (Porter)  
 Tzaddi  
 of Qadhe.....536<sup>a</sup>  
 Ucal.....3032<sup>a</sup> (Roberts)  
 of Ithiel.....1543<sup>b</sup> (Genung)  
 Uel.....3032<sup>a</sup>  
 Uknaz.....3032<sup>a</sup>  
 of Kenaz.....1791<sup>b</sup>  
 Ulai.....3032<sup>a</sup> (Pinches)

- Ulam . . . . . 3033<sup>a</sup>  
 Ulla . . . . . 3033<sup>a</sup>  
 Umma . . . . . 365<sup>a</sup> (Clay)  
 Ummah . . . . . 3033<sup>a</sup>  
 Umpire  
   of Daysman . . . . . 799<sup>a</sup> (A. W. Evans)  
 Unbelief . . . . . 3033<sup>a</sup> (Dunelm)  
 Unbeliever . . . . . 3033<sup>a</sup>  
 Uncertain, Uncertainty . . . . . 3033<sup>a</sup>  
 Unchangeable, Unchange-  
   ableness . . . . . 3033<sup>a</sup> (Hodge)  
   of Faithful, Faithful-  
   ness . . . . . 1088<sup>b</sup> (Hodge)  
   God as . . . . . 3033<sup>b</sup>  
   of Immutability . . . . . 1461<sup>b</sup>  
   Knowledge and free  
   will . . . . . 3034<sup>b</sup>  
   In natural theology . . . . . 3033<sup>b</sup>  
   Not immobility . . . . . 3034<sup>a</sup>  
   Relations to men . . . . . 3035<sup>a</sup>  
   Relation to world . . . . . 3034<sup>b</sup>  
   In Scripture . . . . . 3033<sup>b</sup>  
 Unchastity  
   of Crimes . . . . . 748<sup>a</sup> (Hirsch)  
   of Lewdness . . . . . 1880<sup>b</sup> (Raffety)  
   of Marriage . . . . . 1996<sup>b</sup> (Eager)  
   of Punishments . . . . . 2504<sup>b</sup> (Hirsch)  
 Uncircumcised . . . . . 3035<sup>b</sup> (Easton)  
   of Circumcision . . . . . 656<sup>b</sup> (T. Lewis)  
 Uncle . . . . . 3035<sup>b</sup>  
   of Relationships, Fam-  
   ily . . . . . 2554<sup>a</sup> (N. and E. D.  
   Isaacs)  
 Unclean  
   of Seed . . . . . 2712<sup>b</sup> (Easton)  
 Unclean Foods  
   of Abomination . . . . . 16<sup>a</sup> (Eager)  
 Uncleaness . . . . . 3035<sup>b</sup> (Williams)  
   of Crimes . . . . . 745<sup>b</sup> (Hirsch)  
   of Filth, Filthiness,  
   Filthy . . . . . 1110<sup>b</sup> (W. L. Walker)  
   of Food . . . . . 1121<sup>b</sup> (Eager)  
   Israel's laws . . . . . 3036<sup>a</sup>  
   of Leper . . . . . 1867<sup>a</sup> (Macalister)  
   In NT . . . . . 3036<sup>b</sup>  
   NT terms . . . . . 3036<sup>a</sup>  
   OT teaching . . . . . 3036<sup>a</sup>  
   OT terms . . . . . 3035<sup>b</sup>  
   of Punishments . . . . . 2504<sup>b</sup> (Hirsch)  
   of Separation . . . . . 2721<sup>b</sup>  
   of Tradition . . . . . 3004<sup>a</sup> (Williams)  
   of Unwashed . . . . . 3038<sup>b</sup> (Williams)  
 Unclean Spirit  
   of Demon, Demonic . . . . . 827<sup>b</sup> (Sweet)  
 Unclothed  
   of Clothed Upon . . . . . 670<sup>a</sup> (Clippinger)  
 Unction . . . . . 3037<sup>a</sup>  
 Undeified . . . . . 3037<sup>a</sup>  
 Undergirding  
   of Ships and Boats . . . . . 2774<sup>a</sup> (Nicol)  
 Underneath . . . . . 3037<sup>a</sup>  
 Undersetter . . . . . 3037<sup>a</sup>  
 Undertake . . . . . 3037<sup>a</sup>  
   of Sure . . . . . 2871<sup>b</sup> (Easton)  
   of Surety . . . . . 2872<sup>a</sup> (Reeve)  
 Unequal . . . . . 3037<sup>b</sup>  
   of Yoke . . . . . 3126<sup>b</sup> (Easton)  
 Unfeigned . . . . . 3037<sup>b</sup>  
 Ungodly . . . . . 3037<sup>b</sup> (W. Evans)  
 Unicorn . . . . . 3037<sup>b</sup>  
   of Rhinoceros . . . . . 2589<sup>a</sup>  
 Union with Christ  
   of Faith . . . . . 1087<sup>b</sup> (Dunelm)  
 Unity . . . . . 3037<sup>b</sup>  
 University  
   of Tarsus . . . . . 2916<sup>a</sup> (Tod)  
 Unknown God . . . . . 3037<sup>b</sup> (Easton)  
   of Athens . . . . . 319<sup>b</sup> (Harry)  
 Unlearned . . . . . 3038<sup>a</sup>  
 Unleavened  
   of Leaven . . . . . 1862<sup>a</sup> (Eager)  
   of Passover . . . . . 2256<sup>a</sup> (N. Isaacs)  
   of Sacrifice in the OT . . . . . 2638<sup>a</sup> (Reeve)  
 Unnatural Vice  
   of Crimes . . . . . 748<sup>a</sup> (Hirsch)  
   of Punishments . . . . . 2504<sup>b</sup> (Hirsch)  
 Unni . . . . . 3038<sup>a</sup>  
 Unno . . . . . 3038<sup>a</sup>  
 Unpardonable Sin  
   of Blasphemy . . . . . 485<sup>b</sup> (Rees)  
 Unquenchable Fire . . . . . 3038<sup>a</sup> (Orr)  
   of Punishment, Ever-  
   lasting . . . . . 2501<sup>b</sup> (Orr)  
 Untempered . . . . . 3038<sup>b</sup> (Patch)  
   of Whitewash . . . . . 3038<sup>b</sup>  
 Untoward . . . . . 3038<sup>b</sup>  
 Unwalled  
   of Village . . . . . 3049<sup>b</sup> (Christie)  
 Unwashed . . . . . 3038<sup>b</sup> (Williams)  
   of Purity . . . . . 2506<sup>b</sup> (W. L. Walker);  
   2507<sup>b</sup> (Caverno)  
   of Uncleaness . . . . . 3035<sup>b</sup> (Williams)  
 Unworthy . . . . . 3038<sup>b</sup>  
 Unwritten Sayings  
   of Agrapha . . . . . 72<sup>a</sup> (Smith)  
 Upharsin . . . . . 3038<sup>b</sup>  
   of Mene, Mene, Tekel,  
   Upharsin . . . . . 2032<sup>a</sup> (R. D. Wilson)  
 Uphaz . . . . . 3038<sup>b</sup> (Weir)  
 Upper Chamber, Upper  
   Room . . . . . 3039<sup>a</sup> (Orr)  
   of House . . . . . 1434<sup>b</sup> (A. C. Dickie)  
 Upper Garment  
   of Fisher's Coat . . . . . 1116<sup>a</sup>  
 Ur of the Chaldees . . . . . 3039<sup>a</sup> (Clay)  
   Identifications . . . . . 3039<sup>a</sup>  
   Search for . . . . . 3039<sup>a</sup>  
   of Shinar . . . . . 2773<sup>a</sup> (Pinches)  
   of Table of Nations . . . . . 2899<sup>b</sup> (Pinches)  
   Various views . . . . . 3039<sup>b</sup>  
 Ur (person) . . . . . 3039<sup>a</sup>  
 Urbane  
   of Urbanus . . . . . 3039<sup>b</sup>  
 Urbanus . . . . . 3039<sup>b</sup>  
 Uri . . . . . 3039<sup>b</sup>

- Uriah, Urijah . . . . . 3039<sup>b</sup> (Easton)  
   of Ahikam . . . . . 84<sup>a</sup> (Beecher)  
   of Altar . . . . . 106<sup>b</sup> (Wiener)  
   of Bathsheba . . . . . 416<sup>a</sup> (Breslich)  
   of Marmoth (Mere-  
   moth) . . . . . 1996<sup>a</sup>  
 Urias . . . . . 3040<sup>a</sup>  
   of Uriah, Urijah . . . . . 3039<sup>b</sup> (Easton)  
 Urias . . . . . 3040<sup>a</sup>  
 Uriel (archangel) . . . . . 3040<sup>a</sup> (Angus)  
 Uriel (person) . . . . . 3040<sup>a</sup>  
 Urijah  
   of Uriah, Urijah . . . . . 3039<sup>b</sup> (Easton)  
 Urim and Thummim . . . . . 3040<sup>b</sup> (N. Isaacs)  
   Critical view . . . . . 3041<sup>a</sup>  
   Definition . . . . . 3040<sup>b</sup>  
   Etymology . . . . . 3041<sup>b</sup>  
   of Integrity . . . . . 1484<sup>a</sup> (W. L. Walker)  
   of Priests and Levites. 2452<sup>a</sup> (Wiener)  
   Traditional view . . . . . 3041<sup>a</sup>  
   Use in OT . . . . . 3040<sup>b</sup>  
 Urumma . . . . . 365<sup>b</sup> (Clay)  
 Use  
   of Abuse . . . . . 26<sup>b</sup>  
 Usury . . . . . 3041<sup>b</sup> (Pollard)  
   of Interest . . . . . 1488<sup>b</sup> (Reeve)  
 Uta . . . . . 3042<sup>a</sup>  
 Uthai . . . . . 3042<sup>a</sup>  
 Uthi . . . . . 3042<sup>b</sup>  
 Utilitarianism . . . . . 1019<sup>a</sup> (Alexander)  
 Utmost, Uttermost Sea  
   of Mediterranean Sea. 2026<sup>b</sup> (Heidel)  
 Uttermost . . . . . 3042<sup>a</sup>  
 Uz (person) . . . . . 3042<sup>a</sup> (Reeve)  
 Uz (place) . . . . . 3042<sup>b</sup> (Weir)  
   of Jerusalem . . . . . 1595<sup>b</sup> (Masterman)  
   of Sheba . . . . . 2752<sup>b</sup> (Weir)  
 Uzai . . . . . 3042<sup>b</sup>  
 Uzal . . . . . 3042<sup>b</sup> (Fulton)  
 Uzza, Uzzah . . . . . 3043<sup>a</sup> (Roberts)  
 Uzzen-sheerah . . . . . 3043<sup>a</sup>  
 Uzzi . . . . . 3043<sup>a</sup> (Roberts)  
 Uzzia . . . . . 3043<sup>b</sup>  
 Uzziah (Azariah) . . . . . 3043<sup>b</sup> (Caldecott)  
   Accession and reign . . . . . 3043<sup>b</sup>  
   Chronology of . . . . . 3044<sup>a</sup>  
   Leprosy of . . . . . 3043<sup>b</sup>  
   Name, the . . . . . 3043<sup>b</sup>  
   of Ozias . . . . . 2206<sup>b</sup>  
   of Pekahiah . . . . . 2296<sup>a</sup> (Caldecott)  
 Uzziel . . . . . 3044<sup>b</sup> (Roberts)  
   of Azarel . . . . . 342<sup>a</sup>  
   of Jahaziel . . . . . 1558<sup>b</sup> (Roberts)  
   of Oziel . . . . . 2206<sup>b</sup>  
  
 Vagabond . . . . . 3044<sup>a</sup>  
 Vaheb . . . . . 3044<sup>a</sup>  
   of Suphah . . . . . 2871<sup>b</sup> (Ewing)  
 Vail  
   of Veil . . . . . 3047<sup>a</sup> (Caldecott)  
 Vain . . . . . 3044<sup>a</sup>  
   of Vanity . . . . . 3045<sup>b</sup> (W. L. Walker)  
  
 Vainglory . . . . . 3044<sup>b</sup> (W. L. Walker)  
   of Vanity . . . . . 3045<sup>b</sup> (W. L. Walker)  
 Vaizatha, Vajezatha . . . . . 3044<sup>b</sup>  
 Vale of Siddim  
   of Admah . . . . . 56<sup>b</sup> (Wright)  
 Vale, Valley . . . . . 3045<sup>a</sup> (Day)  
   of Brook . . . . . 523<sup>b</sup> (Day)  
   of Champaign . . . . . 592<sup>b</sup> (Day)  
   of Jerusalem . . . . . 1599<sup>a</sup> (Masterman)  
   of Lowland . . . . . 1934<sup>b</sup> (Day)  
   of River . . . . . 2595<sup>a</sup> (Day)  
   of Shephelah . . . . . 2762<sup>a</sup> (Ewing)  
   of Stream . . . . . 2866<sup>b</sup> (Day)  
 Valiant, Valiantly . . . . . 3045<sup>b</sup> (W. L. Walker)  
 Valley  
   of River . . . . . 2595<sup>a</sup> (Day)  
   of Vale, Valley . . . . . 3045<sup>a</sup> (Day)  
 Valley of Decision . . . . . 3045<sup>b</sup>  
   of Jehoshaphat, Valley  
   of . . . . . 1583<sup>a</sup> (Masterman)  
 Valley Gate . . . . . 3045<sup>b</sup> (Masterman)  
   of Jerusalem Gates . . . . . 1595<sup>b</sup> (Masterman)  
 Valley of Giants  
   of Rephaim, Vale of . . . . . 2560<sup>a</sup> (Ewing)  
 Valley of Hinnom . . . . . 1393<sup>b</sup> (Masterman)  
   of Topheth . . . . . 2999<sup>b</sup> (Masterman)  
 Valley of Jehoshaphat . . . . . 1583<sup>a</sup> (Masterman)  
 Valley, Jordan . . . . . 1735<sup>a</sup> (Wright)  
 Valley of Keziz  
   of Emek-keziz . . . . . 940<sup>b</sup>  
 Valley of Slaughter . . . . . 2815<sup>a</sup>  
   of Hinnom, Valley of . . . . . 1393<sup>b</sup> (Masterman)  
   of Topheth . . . . . 2999<sup>b</sup> (Masterman)  
 Valley of Sorek . . . . . 2836<sup>b</sup> (Masterman)  
   of Vine . . . . . 3049<sup>b</sup> (Masterman)  
 Valley of Vision . . . . . 3045<sup>b</sup>  
 Vampire . . . . . 3045<sup>b</sup>  
   of Horseleach . . . . . 1424<sup>a</sup> (Day)  
 Vaniah . . . . . 3045<sup>b</sup>  
 Vanity, Vanities . . . . . 3045<sup>b</sup> (W. L. Walker)  
   of Vainglory . . . . . 3044<sup>b</sup> (W. L. Walker)  
 Vapor . . . . . 3046<sup>a</sup> (Day)  
   of Mist . . . . . 2067<sup>a</sup> (Joy)  
 Vashni . . . . . 3046<sup>a</sup>  
 Vashti . . . . . 3046<sup>b</sup> (Urquhart)  
 Vat (fat vessel) . . . . . 1100<sup>a</sup>  
 Vault . . . . . 3046<sup>b</sup>  
   of Divination . . . . . 860<sup>a</sup> (T. W. Davies)  
   of Witchcraft . . . . . 3097<sup>a</sup> (T. W. Davies)  
 Vault of the Earth  
   of Astronomy . . . . . 300<sup>b</sup> (Maunder)  
 Vav  
   of Waw . . . . . 3075<sup>b</sup>  
 Vedan . . . . . 3046<sup>b</sup> (Fulton)  
 Vegetable Foods . . . . . 1121<sup>b</sup> (Eager)  
 Vegetables  
   of Meals . . . . . 2014<sup>a</sup> (Eager)  
 Vehement, Vehemently . . . . . 3046<sup>b</sup> (W. L. Walker)  
 Veil . . . . . 3047<sup>a</sup> (Easton)  
   of Dress . . . . . 875<sup>b</sup> (Eager)  
   of Marriage . . . . . 1996<sup>b</sup> (Eager)  
   of Muffler . . . . . 2093<sup>b</sup>

- Veil (Vail) . . . . . 3047<sup>a</sup>  
 cf Tabernacle . . . . . 2887<sup>b</sup> (Caldecott; Orr)  
 cf Temple . . . . . 2930<sup>a</sup> (Caldecott; Orr)
- Vein . . . . . 3047<sup>b</sup>
- Vengeance  
 cf Avenge . . . . . 340<sup>a</sup> (Breslich)  
 cf Goel . . . . . 1272<sup>b</sup> (Breslich)  
 cf Retribution . . . . . 2570<sup>a</sup> (M'Caig)  
 cf Revenge . . . . . 2587<sup>a</sup> (Breslich)
- Venison . . . . . 3047<sup>b</sup>
- Verdigris  
 cf Scum . . . . . 2706<sup>a</sup>
- Verily, Verity . . . . . 3047<sup>b</sup> (W. L. Walker)
- Vermilion  
 cf Colors . . . . . 674<sup>b</sup> (Patch)
- Version, The Old Latin . . . 1841<sup>a</sup> (Nicol)
- Versions  
 cf American Revised  
 Version . . . . . 116<sup>a</sup> (Easton)  
 cf Arabic Versions . . . . . 221<sup>a</sup> (Weir)  
 cf Armenian Versions . . . 249<sup>b</sup> (Tisdall)  
 cf Coptic Versions . . . . . 708<sup>b</sup> (Tisdall)  
 cf English Versions . . . . . 945<sup>b</sup> (Hutchison)  
 cf Ethiopic Versions . . . 1036<sup>a</sup> (Weir)  
 cf Latin Version, The  
 Old . . . . . 1841<sup>a</sup> (Nicol)  
 cf Manuscripts . . . . . 1984<sup>a</sup> (Richardson)  
 cf Septuagint . . . . . 2722<sup>a</sup> (Thackeray)  
 cf Syriac Versions . . . . . 2883<sup>b</sup> (Nicol)  
 cf Targum . . . . . 2910<sup>a</sup> (J. E. H. Thomson)  
 cf Text and MSS of the  
 NT . . . . . 2950<sup>b</sup> (Sitterly)  
 cf Text of the OT . . . . . 2957<sup>b</sup> (Weir)  
 cf Vulgate . . . . . 3058<sup>b</sup> (Angus)
- Versions, Georgian,  
 Gothic, Slavonic . . . . . 3048<sup>a</sup> (Easton)  
 cf Armenian Versions . . . 249<sup>b</sup> (Tisdall)  
 cf Septuagint . . . . . 2722<sup>a</sup> (Thackeray)
- Very . . . . . 3048<sup>b</sup> (W. L. Walker)
- Vessel . . . . . 3049<sup>a</sup> (Easton)  
 cf Potter . . . . . 2423<sup>b</sup> (Patch)
- Vestments  
 cf Dress . . . . . 875<sup>b</sup> (Eager)
- Vestry . . . . . 3049<sup>a</sup>
- Vex, Vexation . . . . . 3049<sup>a</sup> (W. L. Walker)
- Vial . . . . . 3049<sup>a</sup>
- Vicarious Expiation  
 cf Sacrifice, OT . . . . . 2650<sup>a</sup> (Reeve)
- Vice, Unnatural . . . . . 748<sup>a</sup> (Hirsch)
- Victuals  
 cf Food . . . . . 1121<sup>b</sup> (Eager)
- Vile, Villany . . . . . 3049<sup>a</sup> (W. Evans)
- Village . . . . . 3049<sup>b</sup> (Christie)  
 cf City . . . . . 662<sup>a</sup> (A. C. Dickie)  
 cf Havvoth-jair . . . . . 1345<sup>a</sup> (Ewing)  
 cf Hazar-addar . . . . . 1346<sup>b</sup> (Ewing)  
 cf Hazor . . . . . 1347<sup>b</sup> (Ewing)  
 cf Town . . . . . 3001<sup>a</sup> (Christie)
- Villany  
 cf Vile . . . . . 3049<sup>a</sup> (W. Evans)
- Vine . . . . . 3049<sup>b</sup> (Masterman)  
 cf Agriculture . . . . . 78<sup>a</sup> (Patch)  
 cf Eshcol (place) . . . . . 997<sup>a</sup> (Masterman)
- Vine—*continued*  
 cf Grapes, Wild . . . . . 1293<sup>a</sup>  
 Hebrew words . . . . . 3050<sup>a</sup>  
 cf Press . . . . . 2438<sup>b</sup>  
 cf Sodom, Vine of . . . . . 2821<sup>b</sup> (Masterman)  
 cf Sorek, Valley of . . . . . 2836<sup>b</sup> (Masterman)
- Vinegar . . . . . 3051<sup>a</sup> (Easton)  
 cf Nitre . . . . . 2153<sup>a</sup> (Patch)
- Vineyard  
 cf Vine . . . . . 3049<sup>b</sup> (Masterman)
- Vineyards, Meadow of  
 the  
 cf Abel-cheramim . . . . . 5<sup>b</sup>  
 cf Meadow . . . . . 2013<sup>a</sup> (Day)
- Vintage  
 cf Vine . . . . . 3049<sup>b</sup> (Masterman)
- Viol . . . . . 3051<sup>a</sup>  
 cf Music . . . . . 2094<sup>b</sup> (Millar)
- Violence, Violent . . . . . 3051<sup>a</sup> (Easton)
- Viper . . . . . 3051<sup>b</sup>  
 cf Serpent . . . . . 2736<sup>a</sup> (Day)
- Virgin, Virginitv . . . . . 3051<sup>b</sup> (Easton)  
 cf Immanuel . . . . . 1457<sup>b</sup> (A. W. Evans)  
 cf Maid, Maiden . . . . . 1967<sup>b</sup> (Pollard)  
 cf Virgin-birth of Jesus  
 Christ . . . . . 3052<sup>a</sup> (Sweet)
- Virgin-birth of Jesus  
 Christ . . . . . 3052<sup>a</sup> (Sweet)  
 Apostles' Creed . . . . . 3057<sup>a</sup>  
 Critical question . . . . . 3053<sup>b</sup>  
 Discrepancies, Biblical . . 3054<sup>a</sup>  
 Doctrinal question . . . . . 3055<sup>a</sup>  
 cf Genealogy of Jesus  
 Christ, The . . . . . 1196<sup>a</sup> (Sweet)  
 Historical question . . . . . 3052<sup>b</sup>  
 cf Immaculate Concep-  
 tion . . . . . 1456<sup>b</sup> (Sweet)  
 cf Immanuel . . . . . 1457<sup>b</sup> (A. W. Evans)  
 cf Innocents, Massacre  
 of the . . . . . 1471<sup>a</sup> (Sweet)  
 cf Jesus Christ . . . . . 1630<sup>b</sup>; 1633<sup>b</sup> (Orr)  
 cf Luke, Gospel of . . . . . 1938<sup>b</sup> (A. T. Robertson)  
 cf Mary, Mother of  
 Christ . . . . . 2001<sup>b</sup> (Sweet)  
 Objections . . . . . 3056<sup>b</sup>; 1633<sup>b</sup> (Orr)  
 cf Quotations, NT . . . . . 2518<sup>b</sup> (Sweet)  
 Sources of documents . . . . 3054<sup>b</sup>  
 Textual question . . . . . 3052<sup>a</sup>  
 cf Virgin . . . . . 3051<sup>b</sup> (Easton)
- Virgins, Foolish  
 cf Marriage . . . . . 1998<sup>b</sup> (Eager)
- Virgin's Fountain  
 cf Jerusalem . . . . . 1597<sup>b</sup> (Masterman)
- Virtue . . . . . 3057<sup>a</sup> (Edwards)
- Vision . . . . . 3057<sup>b</sup> (Stuart)
- Vision, Valley of . . . . . 3045<sup>b</sup>
- Visitation . . . . . 3058<sup>a</sup> (Edwards)  
 cf Punishments . . . . . 2505<sup>b</sup> (Hirsch)
- Vocation  
 cf Calling . . . . . 545<sup>b</sup> (Trever)
- Voice  
 cf Bath Kol . . . . . 415<sup>b</sup> (Van Pelt)

- Void . . . . . 3058<sup>a</sup>  
   cf Open Place . . . . . 2196<sup>b</sup> (Easton)  
 Volition . . . . . 3085<sup>a</sup> (W. L. Walker)  
 Volume . . . . . 3058<sup>a</sup>  
   cf Roll . . . . . 2597<sup>a</sup> (Richardson)  
 Voluntary . . . . . 3058<sup>a</sup>  
 Vophsi . . . . . 3058<sup>a</sup>  
 Vow . . . . . 3058<sup>a</sup> (Levertoff)  
   cf Jephthah . . . . . 1587<sup>a</sup> (Schenk)  
   cf Nazirite . . . . . 2124<sup>a</sup> (Christie)  
   cf Oath . . . . . 2172<sup>b</sup> (Levertoff)  
 Voyage and Shipwreck  
   of St. Paul  
   cf Paul, the Apostle . . 2264<sup>b</sup> (A. T. Robertson)  
   cf Phoenix . . . . . 2391<sup>a</sup> (Calder)  
 Vulgate . . . . . 3058<sup>b</sup> (Angus); 462<sup>a</sup> (Orr)  
   Jerome's work . . . . . 3060<sup>a</sup>  
   Later history . . . . . 3061<sup>a</sup>  
   cf Latin . . . . . 1840<sup>b</sup> (A. T. Robertson)  
   cf Latin Version, The  
     Old . . . . . 1841<sup>a</sup> (Nicol)  
     Name and history . . . 3058<sup>b</sup>  
     Origin . . . . . 3059<sup>b</sup>  
     cf Septuagint . . . . . 2727<sup>b</sup> (Thackeray)  
 Vulture . . . . . 3062<sup>b</sup> (Stratton-Porter)
- Wafer  
   cf Bread . . . . . 514<sup>b</sup> (Eager)  
 Wages . . . . . 3063<sup>a</sup> (Raffety)  
 Wagon, Waggon  
   cf Cart . . . . . 581<sup>a</sup> (Patch)  
 Wail, Wailing  
   cf Burial . . . . . 529<sup>a</sup> (Eager)  
 Wait . . . . . 3063<sup>b</sup> (A. W. Evans)  
 Walk . . . . . 3064<sup>a</sup> (Miller)  
 Wall  
   cf Architecture . . . . . 234<sup>a</sup> (A. C. Dickie)  
   cf City . . . . . 662<sup>a</sup> (A. C. Dickie)  
   cf Fortification . . . . . 1137<sup>b</sup> (Nicol)  
   cf House . . . . . 1434<sup>b</sup> (A. C. Dickie)  
   cf Jerusalem . . . . . 1602<sup>b</sup> (Masterman)  
   cf Village . . . . . 3049<sup>b</sup> (Christie)  
 Wallet  
   cf Scrip . . . . . 2705<sup>b</sup>  
 Wandering Stars  
   cf Astronomy . . . . . 300<sup>b</sup> (Maunder)  
 Wanderings of Israel . . 3064<sup>a</sup> (Conder)  
   Arabah . . . . . 3065<sup>a</sup>  
   cf Alush . . . . . 112<sup>b</sup>  
   Difficulties . . . . . 3065<sup>b</sup>  
   Exodus . . . . . 3066<sup>b</sup>; 3069<sup>b</sup>  
   Final journey . . . . . 3068<sup>b</sup>  
   First journey . . . . . 3066<sup>a</sup>  
   cf Haradah . . . . . 1337<sup>a</sup>  
   cf Hashmonah . . . . . 1342<sup>a</sup>  
   cf Hazeroth . . . . . 1347<sup>b</sup>  
   cf Hittites . . . . . 1395<sup>b</sup> (Conder)  
   cf Hor-haggidgad . . . . 1421<sup>b</sup>  
   cf Kadesh-barnea . . . . 1788<sup>b</sup> (S. F. Hunter)  
   cf Kehelathah . . . . . 1791<sup>a</sup>  
   cf Libnah . . . . . 1881<sup>b</sup> (Masterman)  
   cf Makheloth . . . . . 1969<sup>a</sup>
- Wanderings of Israel—*continued*  
   cf Marah . . . . . 1984<sup>b</sup>  
   cf Moseroth . . . . . 2083<sup>b</sup>  
   cf Moses . . . . . 2088<sup>a</sup> (Kyle)  
   cf Numbers, Book of . . . 2163<sup>a</sup> (Whitelaw)  
   cf Oboth . . . . . 2177<sup>b</sup>  
   cf Punon . . . . . 2506<sup>a</sup>  
   Regions included . . . . . 3064<sup>b</sup>  
   cf Rimmon-perez . . . . . 2594<sup>a</sup>  
   cf Rissah . . . . . 2594<sup>b</sup>  
   cf Rithmah . . . . . 2595<sup>a</sup>  
   cf Shepher . . . . . 2763<sup>a</sup>  
   cf Shur . . . . . 2782<sup>a</sup> (Conder)  
   Sinai and Kadesh . . . . . 3067<sup>a</sup>  
     cf Sinai . . . . . 2802<sup>b</sup> (Conder)  
   cf Terah . . . . . 2949<sup>a</sup>  
   Thirty-eight years . . . . 3068<sup>a</sup>  
 War, Warfare . . . . . 3069<sup>b</sup> (Nicol)  
   cf Army . . . . . 254<sup>b</sup> (Nicol)  
   cf Fortification . . . . . 1137<sup>b</sup> (Nicol)  
   cf Fray . . . . . 1145<sup>a</sup>  
   NT references . . . . . 3071<sup>b</sup>  
   Operations of . . . . . 3070<sup>a</sup>  
   cf Praetorian Guard . . . 2427<sup>b</sup> (Rutherford)  
   cf Rearward . . . . . 2534<sup>b</sup>  
   Treaties of peace . . . . . 3071<sup>b</sup>  
     cf Treaty . . . . . 3008<sup>b</sup> (Nicol)  
   Ward . . . . . 3072<sup>a</sup> (Easton)  
   cf Watch . . . . . 3074<sup>a</sup> (Porter)  
   Wares . . . . . 3072<sup>a</sup> (Raffety)  
   cf Fairs . . . . . 1087<sup>b</sup>  
   cf Merchandise . . . . . 2035<sup>a</sup> (Raffety)  
 Warfare  
   cf War, Warfare . . . . . 3069<sup>b</sup> (Nicol)  
 War, Man of . . . . . 3072<sup>a</sup>  
   cf God, Names of . . . . . 1264<sup>b</sup> (Mack)  
   cf Lord of Hosts . . . . . 1919<sup>a</sup>  
 Warning Stone  
   cf Partition, Middle  
     Wall of . . . . . 2253<sup>b</sup> (Rutherford)  
 Warp . . . . . 3072<sup>a</sup>  
   cf Weaving . . . . . 3077<sup>a</sup> (Patch)  
 Wars of Jehovah, Book of  
   the  
   cf Bible, The . . . . . 459<sup>b</sup> (Orr)  
 Wash, Washing . . . . . 3072<sup>b</sup> (Easton)  
   cf Soap . . . . . 2820<sup>b</sup> (Patch)  
 Washing of Feet . . . . . 3072<sup>b</sup> (Anderson)  
   According to belief of  
   Church of the Brethren  
   . . . . . 3073<sup>a</sup> (Kurtz)  
   cf Lord's Supper  
   (Dunkers) . . . . . 1928<sup>b</sup> (Kurtz)  
 Washpot . . . . . 3073<sup>b</sup>  
 Wasp  
   cf Hornet . . . . . 1422<sup>b</sup> (Day)  
 Watch . . . . . 3074<sup>a</sup> (Porter)  
   cf Midnight . . . . . 2050<sup>a</sup> (Porter)  
   cf Morning-watch . . . . . 2083<sup>a</sup>  
   cf Night-watch . . . . . 2145<sup>a</sup>  
   cf Ward . . . . . 3072<sup>a</sup> (Easton)  
 Watcher . . . . . 3074<sup>a</sup> (Christie)

- Watchman . . . . . 3074<sup>a</sup> (Christie)  
 cf Gardener . . . . . 1175<sup>a</sup>  
 Watch-tower . . . . . 3074<sup>a</sup>  
 cf Fortification . . . . . 1137<sup>b</sup> (Nicol)  
 cf Mizpah, Mizpeh . . . . . 2068<sup>a</sup> (Ewing)  
 Water . . . . . 3074<sup>a</sup> (Joy)  
 cf Cistern . . . . . 657<sup>b</sup> (A. C. Dickie)  
 cf Fountain . . . . . 1141<sup>b</sup> (Day)  
 cf Pit . . . . . 2401<sup>b</sup> (T. Lewis)  
 cf Pool . . . . . 2419<sup>b</sup> (Day)  
 cf Well . . . . . 3081<sup>a</sup> (Day)  
 Water of Bitterness  
 cf Adultery . . . . . 63<sup>a</sup> (Margolis)  
 cf Heifer, Red . . . . . 1367<sup>b</sup> (Easton)  
 Water of Jealousy  
 cf Adultery . . . . . 63<sup>a</sup> (Margolis)  
 Water of Separation  
 cf Defilement . . . . . 818<sup>a</sup> (Crannell)  
 cf Separation . . . . . 2721<sup>b</sup>  
 cf Uncleanness . . . . . 3035<sup>b</sup> (Williams)  
 Water of Uncleanness  
 cf Defilement . . . . . 818<sup>a</sup> (Crannell)  
 cf Separation . . . . . 2721<sup>b</sup>  
 cf Uncleanness . . . . . 3035<sup>b</sup> (Williams)  
 Watercourse . . . . . 3074<sup>b</sup> (Day)  
 cf Brook . . . . . 523<sup>b</sup> (Day)  
 cf River . . . . . 2595<sup>a</sup> (Day)  
 cf Stream . . . . . 2866<sup>b</sup> (Day)  
 cf Waterfall . . . . . 3074<sup>b</sup>  
 Waterfall . . . . . 3074<sup>b</sup>  
 cf Watercourse . . . . . 3074<sup>b</sup> (Day)  
 cf Waterspout . . . . . 3075<sup>a</sup> (Day)  
 Waterpot . . . . . 3075<sup>a</sup>  
 Waters . . . . . 3075<sup>a</sup> (Day)  
 Waters of Merom . . . . . 2037<sup>a</sup> (Wright)  
 Waters of Strife  
 cf Massah and Meri-  
   bah . . . . . 2007<sup>a</sup> (Ewing)  
 Waterspout . . . . . 3075<sup>a</sup> (Day)  
 cf Dragon . . . . . 873<sup>a</sup> (Day)  
 cf Sea-monster . . . . . 2707<sup>a</sup> (Day)  
 cf Waterfall . . . . . 3074<sup>b</sup>  
 Wave Offering  
 cf Sacrifice in the OT. . . . . 2638<sup>a</sup> (Reeve)  
 Waw . . . . . 3075<sup>b</sup>  
 cf Alphabet . . . . . 103<sup>b</sup> (Richardson)  
 Wax . . . . . 3075<sup>b</sup>  
 cf Writing . . . . . 3114<sup>a</sup> (Richardson)  
 Way . . . . . 3075<sup>b</sup> (Morro)  
 cf Path, Pathway . . . . . 2263<sup>a</sup> (Edwards)  
 Way, Covered . . . . . 733<sup>a</sup> (Hirsch)  
 Way, Little . . . . . 3076<sup>a</sup>  
 Wayfaring Man . . . . . 3076<sup>a</sup>  
 Waymark . . . . . 3076<sup>a</sup>  
 Wealth, Wealthy . . . . . 3076<sup>a</sup> (W. Evans)  
 cf Riches . . . . . 2590<sup>b</sup> (Forrester)  
 Wean . . . . . 3076<sup>b</sup> (Easton)  
 Weapons  
 cf Armor, Arms . . . . . 251<sup>a</sup> (Nicol)  
 Weasel . . . . . 3076<sup>b</sup> (Day)  
 cf Lizard . . . . . 1906<sup>a</sup> (Day)  
 cf Mole . . . . . 2074<sup>a</sup> (Day)  
 Weather . . . . . 3077<sup>a</sup> (Joy)  
 Weaving . . . . . 3077<sup>a</sup> (Patch)  
 cf Agriculture . . . . . 78<sup>a</sup> (Patch)  
 cf Camel's Hair . . . . . 548<sup>a</sup> (Patch)  
 cf Goatskins . . . . . 1249<sup>b</sup>  
 cf Hair . . . . . 1320<sup>a</sup> (Luering)  
 cf Silk, Silkworm . . . . . 2790<sup>b</sup> (Day)  
 cf Tent . . . . . 2947<sup>b</sup> (Patch)  
 cf Warp . . . . . 3072<sup>a</sup>  
 Web  
 cf Spider . . . . . 2840<sup>b</sup> (Day)  
 cf Weaving . . . . . 3077<sup>a</sup> (Patch)  
 Wedding  
 cf Marriage . . . . . 1996<sup>b</sup> (Eager)  
 Wedge of Gold . . . . . 3078<sup>b</sup> (Porter)  
 cf Money . . . . . 2076<sup>a</sup> (Porter)  
 cf Pound . . . . . 2426<sup>b</sup> (Porter)  
 Weeds . . . . . 3078<sup>b</sup>  
 cf Cockle . . . . . 672<sup>b</sup> (Masterman)  
 cf Flag . . . . . 1117<sup>b</sup>  
 cf Red Sea . . . . . 2538<sup>b</sup> (Wright)  
 Week . . . . . 3078<sup>b</sup>  
 cf Astrology . . . . . 295<sup>b</sup> (Maunder)  
 cf Astronomy . . . . . 300<sup>b</sup> (Maunder)  
 cf Time . . . . . 2981<sup>b</sup> (Porter)  
 Weeks, Feast of  
 cf Pentecost . . . . . 2318<sup>a</sup> (Dosker)  
 Weeks, Seventy . . . . . 2744<sup>a</sup> (Orr)  
 Weeping  
 cf Burial . . . . . 529<sup>a</sup> (Eager)  
 Weight . . . . . 3079<sup>a</sup> (Porter)  
 cf Weights and Meas-  
   ures . . . . . 3079<sup>a</sup> (Porter)  
 Weights and Measures . . . . . 3079<sup>a</sup> (Porter)  
 cf Fathom . . . . . 1101<sup>b</sup>  
 cf Finger (measure) . . . . . 1111<sup>b</sup>  
 cf Firkin . . . . . 1113<sup>a</sup>  
 cf Handbreadth . . . . . 1334<sup>b</sup>  
 cf Hin . . . . . 1393<sup>a</sup>  
 cf Homer . . . . . 1418<sup>a</sup>  
 cf Kab . . . . . 1788<sup>a</sup>  
 cf Lethech . . . . . 1868<sup>b</sup>  
 cf Line . . . . . 1894<sup>a</sup> (Orr)  
 Linear measures . . . . . 3079<sup>b</sup>  
 cf Log . . . . . 1910<sup>a</sup>  
 cf Manch (Mina) . . . . . 1981<sup>a</sup> (Porter)  
 Measures of capacity . . . . . 3080<sup>b</sup>  
 cf Measuring Line . . . . . 2016<sup>a</sup> (Porter)  
 cf Mile . . . . . 2051<sup>b</sup>  
 cf Money . . . . . 2076<sup>a</sup> (Porter)  
 cf Omer . . . . . 2188<sup>b</sup>  
 cf Pound . . . . . 2426<sup>b</sup> (Porter)  
 cf Reed, Measuring . . . . . 2545<sup>a</sup> (Orr)  
 cf Sabbath Day's Jour-  
   ney . . . . . 2634<sup>a</sup> (Porter)  
 cf Seah . . . . . 2708<sup>a</sup>  
 cf Shekel . . . . . 2758<sup>a</sup> (Porter)  
 cf Shekel of the King's  
   Weight, or Royal  
   Shekel . . . . . 2758<sup>b</sup>  
 Weights . . . . . 3080<sup>a</sup>

- Well . . . . . 3081<sup>a</sup> (Day); 658<sup>b</sup>  
 (A. C. Dickie)  
 cf Cistern . . . . . 657<sup>b</sup> (A. C. Dickie)  
 cf Fountain . . . . . 1141<sup>b</sup> (Day)  
 cf Pit . . . . . 2401<sup>b</sup> (T. Lewis)  
 cf Pool . . . . . 2419<sup>b</sup> (Day)  
 cf Water . . . . . 3074<sup>a</sup> (Joy)  
 cf Wellspring . . . . . 3082<sup>a</sup>
- Well of Harod . . . . . 1340<sup>b</sup> (Ewing)  
 cf Gilboa, Mount . . . . . 1229<sup>b</sup> (Ewing)
- Well, Jacob's . . . . . 1556<sup>b</sup> (Ewing)
- Wellspring . . . . . 3082<sup>a</sup>  
 cf Well . . . . . 3081<sup>a</sup> (Day)
- Wen . . . . . 3082<sup>a</sup>
- Wench . . . . . 3082<sup>a</sup>
- Wesley, John  
 Doctrine of sanctifica-  
 tion . . . . . 2685<sup>b</sup> (Steele)
- West . . . . . 3082<sup>a</sup> (Day)
- Whale . . . . . 3082<sup>a</sup> (Day)  
 cf Dragon . . . . . 873<sup>a</sup> (Day)  
 cf Fish . . . . . 1114<sup>b</sup> (Day)  
 cf Jackal . . . . . 1548<sup>a</sup> (Day)  
 cf Sea-monster . . . . . 2707<sup>a</sup> (Day)
- Wheat . . . . . 3082<sup>b</sup> (Masterman)  
 cf Corn . . . . . 720<sup>b</sup> (Masterman)  
 cf Food . . . . . 1122<sup>a</sup> (Eager)
- Wheel . . . . . 3082<sup>b</sup> (Easton)  
 cf Agriculture . . . . . 75<sup>b</sup> (Patch)  
 cf Course . . . . . 724<sup>b</sup> (Heidel)  
 cf Potter . . . . . 2423<sup>b</sup> (Patch)
- Whelp . . . . . 3083<sup>a</sup> (Day)  
 cf Dragon . . . . . 873<sup>a</sup> (Day)  
 cf Lion . . . . . 1895<sup>a</sup> (Day)
- Whirlwind . . . . . 3083<sup>a</sup> (Joy)  
 cf Wind . . . . . 3085<sup>b</sup> (Joy)
- White  
 cf Colors . . . . . 674<sup>b</sup> (Patch)
- White Horse . . . . . 1424<sup>a</sup>
- Whitewash . . . . . 3083<sup>b</sup>  
 cf Mortar . . . . . 2083<sup>a</sup> (Orr)  
 cf Untempered . . . . . 3038<sup>b</sup> (Patch)
- Whole, Wholesome . . . . . 3083<sup>b</sup> (Easton)
- Whore, Whoredom  
 cf Crimes . . . . . 745<sup>b</sup> (Hirsch)  
 cf Harlot . . . . . 1339<sup>b</sup> (Eager)  
 cf Punishments . . . . . 2504<sup>b</sup> (Hirsch)
- Wickedness . . . . . 3083<sup>b</sup> (Dungan)  
 cf Sin . . . . . 2798<sup>b</sup> (McConnell)
- Widow . . . . . 3084<sup>a</sup> (Eager)  
 cf Literature, Sub-  
 apos . . . . . 1896<sup>b</sup> (Cowan)  
 cf Woman . . . . . 3103<sup>b</sup> (Pratt)
- Wife  
 cf Family . . . . . 1094<sup>b</sup> (Caverno)  
 cf Marriage . . . . . 1996<sup>b</sup> (Eager)  
 cf Relationships, Fam-  
 ily . . . . . 2554<sup>a</sup> (N. and E. D. Isaacs)
- Wife, Brother's  
 cf Marriage . . . . . 1996<sup>b</sup> (Eager)  
 cf Relationships, Fam-  
 ily . . . . . 2554<sup>a</sup> (N. and E. D. Isaacs)
- Wild Beast . . . . . 3084<sup>a</sup> (Day)  
 cf Jackal . . . . . 1548<sup>a</sup> (Day)
- Wild-ox . . . . . 3084<sup>b</sup> (Day)  
 cf Antelope . . . . . 143<sup>b</sup> (Day)  
 cf Cattle . . . . . 583<sup>b</sup> (Day)
- Wilderness  
 cf Desert . . . . . 831<sup>b</sup> (Day)  
 cf Judaea . . . . . 1757<sup>a</sup> (Masterman)  
 cf Negeb . . . . . 2130<sup>a</sup> (Masterman)  
 cf Wanderings of Is-  
 rael . . . . . 3064<sup>a</sup> (Conder)
- Wilderness of Paran . . . . . 2247<sup>a</sup> (Ewing)
- Will  
 cf Providence . . . . . 2482<sup>a</sup> (Tillett)  
 cf Testament . . . . . 2950<sup>a</sup>
- Will, Volition . . . . . 3085<sup>a</sup> (W. L. Walker)
- Will-worship . . . . . 3085<sup>b</sup>
- Willow . . . . . 507<sup>b</sup> (Masterman)
- Willow Tree . . . . . 3085<sup>b</sup>
- Willows . . . . . 3085<sup>b</sup> (Masterman)
- Willows, Brook of the . . . . . 3085<sup>b</sup>  
 cf Brook . . . . . 523<sup>b</sup> (Day)  
 cf Zered . . . . . 3147<sup>a</sup> (Ewing)
- Wimple . . . . . 3085<sup>b</sup>  
 cf Dress . . . . . 875<sup>b</sup> (Eager)
- Wind . . . . . 3085<sup>b</sup> (Joy)  
 cf Whirlwind . . . . . 3083<sup>a</sup> (Joy)
- Window  
 cf House . . . . . 1434<sup>b</sup> (A. C. Dickie)
- Windows of Heaven  
 cf Astronomy . . . . . 300<sup>b</sup> (Maunder)
- Wine, Wine Press . . . . . 3086<sup>a</sup> (Easton)  
 cf Blood . . . . . 488<sup>b</sup> (Clippinger)  
 cf Crafts . . . . . 734<sup>a</sup> (Patch)  
 cf Drink, Strong . . . . . 879<sup>b</sup> (Edwards)  
 cf Drunkenness . . . . . 880<sup>b</sup> (Edwards)  
 cf Feasts and Fasts . . . . . 1103<sup>a</sup> (E. D. Isaacs)  
 cf Flagon . . . . . 1117<sup>b</sup> (Hovey)  
 cf Food . . . . . 1121<sup>b</sup> (Eager)  
 cf Gath . . . . . 1177<sup>a</sup> (Porter)  
 cf Honey . . . . . 1418<sup>b</sup> (Patch)  
 cf Liquor . . . . . 1896<sup>a</sup>  
 cf Lord's Supper . . . . . 1925<sup>a</sup> (Dosker)  
 cf Press . . . . . 2438<sup>b</sup>  
 cf Sacrifice (OT) . . . . . 2638<sup>a</sup> (Reeve)  
 cf Sickle . . . . . 2784<sup>a</sup> (Patch)  
 cf Spice, Spices . . . . . 2840<sup>a</sup> (Masterman)  
 cf Trade . . . . . 3002<sup>a</sup> (Easton)  
 Use of wine . . . . . 3087<sup>b</sup>  
 cf Vine . . . . . 3049<sup>b</sup> (Masterman)  
 Wine-making . . . . . 3086<sup>b</sup>  
 cf Wine-skins . . . . . 3088<sup>a</sup> (Christie)
- Winebibber . . . . . 3088<sup>a</sup>
- Winefat, Winevat  
 cf Crafts . . . . . 736<sup>b</sup> (Patch)  
 cf Vine . . . . . 3049<sup>b</sup> (Masterman)  
 cf Wine . . . . . 3086<sup>a</sup> (Easton)
- Wine Press . . . . . 3086<sup>a</sup> (Easton)  
 cf Agriculture . . . . . 78<sup>a</sup> (Patch)  
 cf Crafts . . . . . 736<sup>b</sup> (Patch)  
 cf Oil . . . . . 2181<sup>b</sup> (Patch)



- Wine Press—*continued*  
 Terms used . . . . . 3086<sup>a</sup>  
 cf Vine . . . . . 3049<sup>b</sup> (Masterman)  
 cf Wine . . . . . 3086<sup>a</sup> (Easton)  
 Wine-skins . . . . . 3088<sup>a</sup> (Christie)  
 cf Wine . . . . . 3086<sup>a</sup> (Easton)  
 Winevat  
 cf Crafts . . . . . 736<sup>b</sup> (Patch)  
 cf Vine . . . . . 3049<sup>b</sup> (Masterman)  
 cf Wine . . . . . 3086<sup>a</sup> (Easton)  
 Wings . . . . . 3088<sup>b</sup> (Stratton-Porter)  
 Wink . . . . . 3088<sup>b</sup> (A. W. Evans)  
 Winnowing  
 cf Agriculture . . . . . 77<sup>b</sup> (Patch)  
 cf Fan . . . . . 1097<sup>b</sup> (Patch)  
 cf Threshing . . . . . 2975<sup>b</sup> (Patch)  
 Winter . . . . . 3089<sup>a</sup>  
 cf Seasons . . . . . 2710<sup>b</sup> (Joy)  
 Winter-house . . . . . 3089<sup>a</sup>  
 cf Summer-house . . . . . 2870<sup>a</sup>  
 Wisdom . . . . . 3089<sup>a</sup> (Easton)  
 cf Egypt . . . . . 906<sup>a</sup> (Petrie)  
 cf Fool, Folly . . . . . 1124<sup>a</sup> (W. L. Walker)  
 History . . . . . 3089<sup>b</sup>  
 Ideals . . . . . 3090<sup>b</sup>  
 cf Light . . . . . 1890<sup>b</sup> (Pratt)  
 cf Logos . . . . . 1911<sup>b</sup> (Alexander)  
 cf Mediation, Mediator 2021<sup>a</sup> (Edwards)  
 NT ideas . . . . . 3091<sup>a</sup>  
 cf Philo Judaeus . . . . . 2380<sup>a</sup> (Wenley)  
 cf Philosophy . . . . . 2384<sup>b</sup> (Rees)  
 cf Proverbs, Book of . . . . . 2472<sup>b</sup> (Genung)  
 cf Prudence . . . . . 2486<sup>b</sup> (W. L. Walker)  
 cf Wisdom of Solomon . . . . . 3092<sup>a</sup> (T. W. Davies)  
 Wisdom of God . . . . . 3092<sup>a</sup>  
 Wisdom of Jesus  
 cf Sirach, Book of . . . . . 2806<sup>b</sup> (T. W. Davies)  
 Wisdom Literature  
 cf Poetry, Hebrew . . . . . 2413<sup>b</sup> (T. W. Davies)  
 cf Sirach, Book of . . . . . 2806<sup>b</sup> (T. W. Davies)  
 cf Wisdom . . . . . 3089<sup>a</sup> (Easton)  
 Wisdom of Solomon,  
 The . . . . . 3092<sup>a</sup> (T. W. Davies)  
 Aim and author . . . . . 3095<sup>a</sup>  
 Canonicity and con-  
 tents . . . . . 3092<sup>b</sup>  
 Date . . . . . 3095<sup>b</sup>  
 Language and versions 3096<sup>a</sup>  
 cf Logos . . . . . 1911<sup>b</sup> (Alexander)  
 Name . . . . . 3092<sup>b</sup>  
 cf Sirach, Book of . . . . . 2806<sup>b</sup> (T. W. Davies)  
 Teaching . . . . . 3093<sup>b</sup>  
 Unity and integrity . . . . . 3093<sup>b</sup>  
 cf Wisdom . . . . . 3089<sup>a</sup> (Easton)  
 Wise Man  
 cf Wisdom . . . . . 3089<sup>a</sup> (Easton)  
 Wise-Men . . . . . 3096<sup>b</sup> (Easton)  
 cf Astrology . . . . . 295<sup>b</sup> (Maunder)  
 cf Divination . . . . . 860<sup>a</sup> (T. W. Davies)  
 cf Magi, The . . . . . 1962<sup>a</sup> (Tisdall)  
 Wish . . . . . 3096<sup>b</sup> (A. W. Evans)  
 Wist, Witty, Wot . . . . . 3096<sup>b</sup> (Easton)  
 Witch, Witchcraft . . . . . 3097<sup>a</sup> (T. W. Davies)  
 Biblical usage . . . . . 3097<sup>a</sup>  
 cf Divination . . . . . 860<sup>a</sup> (T. W. Davies)  
 cf Endor, Witch of . . . . . 944<sup>a</sup> (Orr)  
 cf Familiar . . . . . 1094<sup>a</sup> (Pollard)  
 Magic . . . . . 3097<sup>b</sup>  
 cf Magic . . . . . 1963<sup>a</sup> (T. W. Davies)  
 Spread and persecu-  
 tion . . . . . 3098<sup>b</sup>  
 cf Vault . . . . . 3046<sup>b</sup>  
 Witchcraft  
 cf Witch, Witchcraft . . . . . 3097<sup>a</sup> (T. W. Davies)  
 Withered . . . . . 3098<sup>b</sup> (A. W. Evans)  
 Withes, Withs, Green . . . . . 3098<sup>b</sup> (Masterman)  
 Witness . . . . . 3099<sup>a</sup> (Levertoff)  
 Witness of the Spirit . . . . . 3099<sup>a</sup> (Dunelm)  
 Witnessing, False . . . . . 748<sup>a</sup> (Hirsch)  
 Witty  
 cf Wist, Witty, Wot . . . . . 3096<sup>b</sup> (Easton)  
 Wizard  
 cf Astrology . . . . . 295<sup>b</sup> (Maunder)  
 cf Divination . . . . . 860<sup>a</sup> (T. W. Davies)  
 cf Familiar . . . . . 1094<sup>a</sup> (Pollard)  
 cf Magic . . . . . 1963<sup>a</sup> (T. W. Davies)  
 cf Witch, Witchcraft . . . . . 3097<sup>a</sup> (T. W. Davies)  
 Wolf . . . . . 3099<sup>b</sup> (Day)  
 cf Island . . . . . 1511<sup>a</sup> (Day)  
 cf Jackal . . . . . 1548<sup>a</sup> (Day)  
 cf Totemism . . . . . 3000<sup>a</sup> (M. O. Evans)  
 Woman . . . . . 3100<sup>a</sup> (Pratt)  
 cf Adam in OT . . . . . 49<sup>b</sup> (Genung)  
 cf Anthropology . . . . . 144<sup>b</sup> (Marais)  
 Creative plan . . . . . 3100<sup>a</sup>  
 cf Deaconess . . . . . 800<sup>a</sup> (Heidel)  
 Later times . . . . . 3103<sup>b</sup>  
 cf Male . . . . . 1971<sup>b</sup> (Luering)  
 cf Marriage . . . . . 1996<sup>b</sup> (Eager)  
 NT ideas . . . . . 3102<sup>b</sup>  
 OT ideas . . . . . 3100<sup>b</sup>  
 cf Polygamy . . . . . 2416<sup>a</sup> (Caverno)  
 cf Susanna, History of . . . . . 2872<sup>b</sup> (T. W. Davies)  
 cf Widow . . . . . 3084<sup>a</sup> (Eager)  
 Wonder, Wonderful . . . . . 3104<sup>b</sup> (W. L. Walker)  
 Wood  
 cf Botany . . . . . 505<sup>a</sup> (Masterman)  
 cf Forest . . . . . 1132<sup>a</sup> (Masterman)  
 Wood of Ephraim  
 cf Ephraim, Forest of . . . . . 963<sup>b</sup>  
 Woof . . . . . 3104<sup>b</sup>  
 cf Warp . . . . . 3072<sup>a</sup>  
 Wool . . . . . 3104<sup>b</sup> (Patch)  
 cf Fuller . . . . . 1148<sup>a</sup> (Patch)  
 cf Tanner . . . . . 2908<sup>b</sup> (Patch)  
 Word . . . . . 3105<sup>a</sup> (W. L. Walker)  
 cf Logos . . . . . 1911<sup>b</sup> (Alexander)  
 cf Person of Christ . . . . . 2338<sup>a</sup> (Warfield)  
 cf Speech . . . . . 2839<sup>b</sup> (W. L. Walker)  
 Work, Works . . . . . 3105<sup>b</sup> (W. L. Walker)  
 cf Justification . . . . . 1782<sup>b</sup> (Faulkner)  
 cf Labor . . . . . 1819<sup>b</sup> (Orr)  
 Worker . . . . . 3105<sup>b</sup> (W. L. Walker)

- Workfellow . . . . . 3105<sup>b</sup> (W. L. Walker)  
 Workman . . . . . 3105<sup>b</sup> (W. L. Walker)  
 World (Cosmological) . . . 3106<sup>a</sup> (Orr)  
   cf Anthropology . . . . . 144<sup>b</sup> (Marais)  
   cf Babylonia and Assyria, Religion of . . . 368<sup>b</sup> (Rogers)  
   Cosmogony of Gen 1 . . . 3107<sup>a</sup>  
   cf Creation . . . . . 738<sup>a</sup> (J. Lindsay)  
   cf Evolution . . . . . 1043<sup>b</sup> (Zenos)  
   Hebrew ideas . . . . . 3106<sup>a</sup>  
 World, End of the  
   cf Eschatology of NT. 979<sup>b</sup> (Vos)  
   cf Heavens, New . . . . . 1353<sup>a</sup> (Vos)  
 World (general) . . . . . 3108<sup>b</sup> (Dunelm)  
   cf Heavenly . . . . . 1352<sup>b</sup> (Orr)  
   cf Johannine Theology 1704<sup>a</sup> (Law)  
 Worm, Scarlet-worm . . . 3109<sup>a</sup> (Day)  
   cf Colors . . . . . 674<sup>b</sup> (Patch)  
   cf Moth . . . . . 2091<sup>b</sup> (Day)  
 Wormwood . . . . . 3109<sup>b</sup> (Masterman)  
 Wormwood, The Star . . . 3110<sup>a</sup> (Orr)  
   cf Astronomy . . . . . 300<sup>b</sup> (Maunder)  
 Worship . . . . . 3110<sup>a</sup> (Crannell)  
   cf Altar . . . . . 106<sup>b</sup> (Wiener)  
   cf In Ancient Greece. 1301<sup>a</sup> (Fairbanks)  
   Christian worship . . . . 3111<sup>a</sup>  
   cf High Place . . . . . 1390<sup>a</sup> (Easton)  
   OT worship . . . . . 3110<sup>b</sup>  
   cf Passover . . . . . 2256<sup>a</sup> (N. Isaacs)  
   cf Praise . . . . . 2429<sup>a</sup> (Lambert)  
   cf Sanctuary . . . . . 2686<sup>b</sup> (Wiener)  
   cf Tabernacle . . . . . 2887<sup>b</sup> (Caldecott; Orr)  
   cf Temple . . . . . 2930<sup>a</sup> (Caldecott; Orr)  
   Terms . . . . . 3110<sup>a</sup>  
   cf Tongues, Gift of . . . 2995<sup>b</sup> (Easton)  
 Worship, Image  
   cf Images . . . . . 1452<sup>a</sup> (Cobern)  
 Worshipper  
   cf Worship . . . . . 3110<sup>a</sup> (Crannell)  
 Worthies . . . . . 3113<sup>a</sup>  
 Wot  
   cf Wist, Witty, Wot. 3096<sup>b</sup> (Easton)  
 Wrath (Anger) . . . . . 3113<sup>a</sup> (W. Evans)  
   cf Fury . . . . . 1150<sup>b</sup>  
   cf Law in NT . . . . . 1844<sup>a</sup> (M'Caig)  
   cf Reconcile, Reconciliation . . . 2536<sup>a</sup> (M'Caig)  
   cf Retribution . . . . . 2570<sup>a</sup> (M'Caig)  
 Wrest . . . . . 3113<sup>b</sup> (Gerberding)  
 Wrestling  
   cf Games . . . . . 1168<sup>b</sup> (Smith)  
   cf Jacob . . . . . 1549<sup>a</sup> (Boyd)  
   cf Naphtali . . . . . 2118<sup>b</sup> (Ewing)  
 Wrinkle . . . . . 3114<sup>a</sup>  
 Writing . . . . . 3114<sup>a</sup> (Richardson); 103<sup>b</sup>  
   (Richardson)  
   cf Alphabet . . . . . 106<sup>a</sup> (Richardson)  
   cf Book . . . . . 495<sup>b</sup> (Richardson)  
   Definition . . . . . 3114<sup>a</sup>  
   Forms . . . . . 3122<sup>a</sup>  
   History of . . . . . 3124<sup>a</sup>  
   cf Ink . . . . . 1469<sup>a</sup> (Richardson)  
   cf Ink-horn . . . . . 1469<sup>b</sup> (Richardson)  
 Writing—*continued*  
   Instruments . . . . . 3119<sup>a</sup>  
   cf Josiah . . . . . 1753<sup>a</sup> (Genung)  
   cf Libraries . . . . . 1882<sup>a</sup> (Richardson)  
   cf Manuscripts . . . . . 1984<sup>a</sup> (Richardson)  
   Materials . . . . . 3119<sup>b</sup>  
   Methods . . . . . 3118<sup>b</sup>  
   cf Money . . . . . 2076<sup>a</sup> (Porter)  
   cf Nineveh, Library  
     of . . . . . 2151<sup>b</sup> (Sayce)  
   cf Ostraca . . . . . 2202<sup>b</sup> (Goodspeed)  
   cf Palestine . . . . . 2216<sup>b</sup> (Conder)  
   cf Papyrus . . . . . 2242<sup>b</sup> (Goodspeed)  
   cf Parchments . . . . . 2248<sup>a</sup> (Rutherford)  
   cf Pen . . . . . 2297<sup>b</sup> (Patch)  
   cf Pentateuch, Samaritan . . . . . 2313<sup>b</sup> (J. E. H. Thomson)  
   Picture writing . . . . . 3117<sup>a</sup>  
   cf Printing . . . . . 2455<sup>a</sup> (Richardson)  
   cf Roll . . . . . 2597<sup>a</sup> (Richardson)  
   cf Septuagint . . . . . 2722<sup>a</sup> (Thackeray)  
   cf Shinar . . . . . 2773<sup>b</sup> (Pinches)  
   Symbols . . . . . 3115<sup>a</sup>  
   cf Tablet . . . . . 2900<sup>a</sup> (Richardson)  
   cf Text of the OT . . . . 2957<sup>b</sup> (Weir)  
   cf Wax . . . . . 3075<sup>b</sup>  
   Writers . . . . . 3123<sup>a</sup>  
 Wycliffe, John . . . . . 946<sup>b</sup> (Hutchison)  
 Xanthicus . . . . . 3126<sup>a</sup>  
   cf Calendar . . . . . 541<sup>b</sup> (Porter)  
   cf Time . . . . . 2981<sup>b</sup> (Porter)  
   cf Year . . . . . 3126<sup>a</sup>  
 Xerxes . . . . . 3126<sup>a</sup> (Easton)  
   cf Ahasuerus . . . . . 80<sup>b</sup> (R. D. Wilson)  
   cf Persians . . . . . 2336<sup>b</sup> (Tisdall)  
 Yarn  
   cf Linen . . . . . 1894<sup>a</sup> (E. D. Isaacs)  
   cf Spinning . . . . . 2841<sup>a</sup> (Patch)  
   cf Weaving . . . . . 3077<sup>a</sup> (Patch)  
 Yea . . . . . 3126<sup>a</sup> (Hirsch)  
 Year . . . . . 3126<sup>a</sup>  
   cf Astronomy . . . . . 300<sup>b</sup> (Maunder)  
   cf Time . . . . . 2982<sup>a</sup> (Porter)  
 Years, Seventy . . . . . 2744<sup>b</sup>  
 Yellow  
   cf Colors . . . . . 674<sup>b</sup> (Patch)  
 Yodh . . . . . 3126<sup>a</sup>  
   cf Alphabet . . . . . 103<sup>b</sup> (Richardson)  
   cf Jod . . . . . 1688<sup>a</sup>  
   cf Tittle . . . . . 2988<sup>b</sup>  
 Yoke . . . . . 3126<sup>b</sup> (Easton)  
   cf Unequal . . . . . 3037<sup>b</sup>  
   cf Yoke-fellow . . . . . 3127<sup>a</sup> (Rutherford)  
 Yoke-fellow . . . . . 3127<sup>a</sup> (Rutherford)  
   cf Syntyche . . . . . 2880<sup>a</sup> (Rutherford)  
   cf Synzygus . . . . . 2880<sup>a</sup>  
   cf Yoke . . . . . 3126<sup>b</sup> (Easton)  
 Young Men . . . . . 3127<sup>b</sup> (W. L. Walker)  
 Young Women . . . . . 3127<sup>b</sup> (W. L. Walker)

- Zaanaim  
 cf Zaanannim . . . . . 3128<sup>a</sup> (Ewing)
- Zaanan . . . . . 3128<sup>a</sup>
- Zaanannim, Plain or Oak  
 of . . . . . 3128<sup>a</sup> (Ewing)
- Zaavan . . . . . 3128<sup>a</sup>
- Zabad . . . . . 3128<sup>a</sup> (Roberts)  
 cf Nathan . . . . . 2121<sup>a</sup> (Roberts)  
 cf Sabanneus (Apoc) . . . . . 2629<sup>b</sup>  
 cf Sabathus (Apoc) . . . . . 2629<sup>b</sup>
- Zabadaeans . . . . . 3128<sup>b</sup> (Easton)
- Zabadaias  
 cf Zabadeas . . . . . 3128<sup>b</sup>
- Zabadeas . . . . . 3128<sup>b</sup>
- Zabbai . . . . . 3128<sup>b</sup>
- Zabbud . . . . . 3128<sup>b</sup>  
 cf Zaccur . . . . . 3129<sup>a</sup> (Roberts)
- Zabdeus . . . . . 3128<sup>b</sup>  
 cf Zebadiah . . . . . 3133<sup>b</sup> (Roberts)
- Zabdi . . . . . 3128<sup>b</sup> (Roberts)  
 cf Zichri . . . . . 3149<sup>a</sup> (Roberts)  
 cf Zimri . . . . . 3149<sup>b</sup> (Roberts)
- Zabdiel . . . . . 3128<sup>b</sup>  
 cf Zebadiah . . . . . 3133<sup>b</sup> (Roberts)
- Zabud . . . . . 3128<sup>b</sup> (Roberts)  
 cf Priests and Levites. 2446<sup>b</sup> (Wiener)  
 cf Shebna . . . . . 2753<sup>b</sup> (Roberts)  
 cf Zaccur . . . . . 3129<sup>a</sup> (Roberts)
- Zabulon . . . . . 3129<sup>a</sup>
- Zaceai  
 cf Zabbai . . . . . 3128<sup>b</sup>
- Zacchaeus . . . . . 3129<sup>a</sup> (Kerr)
- Zacchur  
 cf Zaccur . . . . . 3129<sup>a</sup> (Roberts)
- Zaccur . . . . . 3129<sup>a</sup> (Roberts)  
 cf Zabbud . . . . . 3128<sup>b</sup>  
 cf Zabud . . . . . 3128<sup>b</sup> (Roberts)  
 cf Zechariah (general) 3135<sup>b</sup> (Easton)
- Zachariah . . . . . 3129<sup>a</sup>  
 cf Berechiah . . . . . 439<sup>b</sup>  
 cf Jerusalem Tombs. 1611<sup>b</sup> (Masterman)  
 cf Zechariah (general) 3135<sup>b</sup> (Easton)
- Zacharias . . . . . 3129<sup>b</sup> (Angus); 3129<sup>b</sup> (Easton)  
 cf Abijah . . . . . 10<sup>a</sup> (Beecher)  
 cf Temple . . . . . 2930<sup>a</sup> (Caldecott; Orr)  
 cf Zaraias . . . . . 3132<sup>a</sup>
- Zachary . . . . . 3129<sup>b</sup>
- Zacher  
 cf Zecher . . . . . 3140<sup>b</sup>
- Zadok . . . . . 3129<sup>b</sup> (Whitelaw); 8<sup>a</sup> (Beecher)  
 Chronicles . . . . . 3130<sup>a</sup>  
 Critical views . . . . . 3131<sup>a</sup>  
 cf Ithamar . . . . . 1543<sup>a</sup> (Whitelaw)  
 cf Priests and Levites. 2446<sup>b</sup> (Wiener)  
 cf Sadduk . . . . . 2661<sup>a</sup>  
 In Samuel and Kings. 3130<sup>a</sup>
- Zaham . . . . . 3131<sup>b</sup>
- Zain  
 cf Zayin . . . . . 3133<sup>a</sup>
- Zair . . . . . 3131<sup>b</sup>
- Zalaph . . . . . 3131<sup>b</sup>
- Zalmon . . . . . 3131<sup>b</sup> (Ewing)  
 cf Ilai . . . . . 1449<sup>a</sup>  
 cf Salmon, Salma . . . . . 2663<sup>b</sup> (S. F. Hunter)
- Zalmonah . . . . . 3131<sup>b</sup>  
 cf Wanderings of Is-  
 rael . . . . . 3064<sup>a</sup> (Conder)
- Zalmunna  
 cf Zebah and Zalmunna 3133<sup>b</sup> (Roberts)
- Zambis (Zambri) . . . . . 3131<sup>b</sup>
- Zambri . . . . . 3131<sup>b</sup>
- Zamoth . . . . . 3131<sup>b</sup>  
 cf Zathui . . . . . 3133<sup>a</sup>
- Zamzummim . . . . . 3132<sup>a</sup>  
 cf Rephaim . . . . . 2559<sup>b</sup> (Porter)
- Zanoah . . . . . 3132<sup>a</sup> (Ewing)
- Zaphenath-paneah . . . . . 3132<sup>a</sup>  
 cf Joseph . . . . . 1736<sup>b</sup> (S. F. Hunter)
- Zaphnath-paaneah  
 cf Zaphenath-paneah. 3132<sup>a</sup>
- Zaphon . . . . . 3132<sup>a</sup> (Ewing)
- Zara . . . . . 3132<sup>a</sup>  
 cf Zerah (the Ethi-  
 opian) . . . . . 3146<sup>b</sup> (Cobern)
- Zaraces  
 cf Zarakes . . . . . 3132<sup>b</sup>
- Zarah  
 cf Zerah (general) . . . . . 3146<sup>b</sup> (Roberts)
- Zaraias . . . . . 3132<sup>a</sup>  
 cf Zacharias . . . . . 3129<sup>b</sup> (Angus)
- Zarakes . . . . . 3132<sup>b</sup>
- Zardeus (Sardeus) . . . . . 3132<sup>b</sup>
- Zareah . . . . . 3132<sup>b</sup>  
 cf Zorah . . . . . 3157<sup>a</sup> (Masterman)
- Zareathites  
 cf Zorathites . . . . . 3157<sup>a</sup>
- Zared . . . . . 3132<sup>b</sup>  
 cf Zered . . . . . 3147<sup>a</sup> (Ewing)
- Zarephath . . . . . 3132<sup>b</sup> (Ewing)  
 cf Misrephoth-maim. 2067<sup>a</sup> (Porter)  
 cf Sarepta . . . . . 2692<sup>b</sup>  
 cf Sidon . . . . . 2785<sup>a</sup> (Porter)
- Zaretan . . . . . 3132<sup>b</sup>  
 cf Zarethan . . . . . 3133<sup>a</sup> (Wright)
- Zarethan . . . . . 3133<sup>a</sup> (Wright)
- Zareth-shahar  
 cf Zereth-shahar. . . . . 3147<sup>b</sup>
- Zarhites  
 cf Zerah (general) . . . . . 3146<sup>b</sup> (Roberts)  
 cf Zerabites . . . . . 3147<sup>a</sup>
- Zartanah . . . . . 3133<sup>a</sup>
- Zarthan . . . . . 3133<sup>a</sup>  
 cf Zarethan . . . . . 3133<sup>a</sup> (Wright)
- Zathoes . . . . . 3133<sup>a</sup>  
 cf Zattu . . . . . 3133<sup>a</sup> (Roberts)
- Zathui . . . . . 3133<sup>a</sup>
- Zatthu . . . . . 3133<sup>a</sup>  
 cf Zattu . . . . . 3133<sup>a</sup> (Roberts)
- Zattu . . . . . 3133<sup>a</sup> (Roberts)
- Zavan  
 cf Zaavan . . . . . 3128<sup>a</sup>

- Zayin . . . . . 3133<sup>a</sup>  
 cf Alphabet . . . . . 103<sup>b</sup> (Richardson)
- Zaza . . . . . 3133<sup>a</sup>
- Zealot, Zealots . . . . . 3133<sup>b</sup> (Heidel)  
 cf Assassins . . . . . 288<sup>a</sup> (S. F. Hunter)  
 cf Josephus Flavius . . . 1742<sup>a</sup> (Wenley)  
 cf Simon, the Zealot . . 2797<sup>b</sup> (Kerr)
- Zebadiah . . . . . 3133<sup>b</sup> (Roberts)  
 cf Zabdeus . . . . . 3128<sup>b</sup>  
 cf Zabdi . . . . . 3128<sup>b</sup> (Roberts)  
 cf Zabdiel . . . . . 3128<sup>b</sup>
- Zebah and Zalmunna . . . 3133<sup>b</sup> (Roberts)
- Zebaim  
 cf Pochereth-hazze-  
 baim . . . . . 2410<sup>a</sup>
- Zebedee . . . . . 3134<sup>a</sup>  
 cf James, Son of Zebe-  
 dee . . . . . 1560<sup>a</sup> (Kerr)  
 cf Salome . . . . . 2664<sup>a</sup> (Orr)  
 cf Zabdi . . . . . 3128<sup>b</sup> (Roberts)
- Zebidah . . . . . 3134<sup>a</sup> (Roberts)
- Zebina . . . . . 3134<sup>a</sup>
- Zeboim . . . . . 3134<sup>a</sup>  
 cf Siddim, Vale of . . . 2784<sup>a</sup> (Wright)
- Zeboim . . . . . 3134<sup>a</sup> (Masterman)  
 cf Hadid . . . . . 1315<sup>b</sup>  
 cf Neballat . . . . . 2126<sup>b</sup>
- Zebudah  
 cf Zebidah . . . . . 3134<sup>a</sup> (Roberts)
- Zebul . . . . . 3134<sup>b</sup> (Roberts)
- Zebulonites  
 cf Zebulunites . . . . . 3135<sup>b</sup>
- Zebulun . . . . . 3135<sup>a</sup> (Ewing)  
 cf Numbers, Book of . . 2163<sup>a</sup> (Whitelaw)
- Zebulunites . . . . . 3135<sup>b</sup>
- Zechariah, Book of . . . . 3136<sup>b</sup> (Robinson)  
 Contents and analysis . . 3137<sup>a</sup>  
 Critical questions . . . . 3137<sup>b</sup>  
 Prophet Zechariah . . . . 3136<sup>b</sup>  
 Question of unity . . . . 3139<sup>b</sup>  
 cf Zechariah (general) . 3135<sup>b</sup> (Easton)
- Zechariah (general) . . . . 3135<sup>b</sup> (Easton)  
 cf Jahaziel . . . . . 1558<sup>b</sup> (Roberts)  
 cf Joshua (son of Jeho-  
 adak) . . . . . 1748<sup>a</sup> (Roberts)  
 Tomb of . . . . . 236<sup>b</sup>  
 cf Zaccur . . . . . 3129<sup>a</sup> (Roberts)  
 cf Zachariah . . . . . 3129<sup>a</sup>  
 cf Zechariah (king) . . 3136<sup>a</sup> (Caldecott)  
 cf Zechariah, Book of . . 3136<sup>b</sup> (Robinson)  
 cf Zecher . . . . . 3140<sup>b</sup>  
 cf Zichri . . . . . 3149<sup>a</sup> (Roberts)
- Zechariah (king) . . . . . 3136<sup>a</sup> (Caldecott)  
 cf Chronology of OT . . 635<sup>a</sup> (Mack)
- Zechariah, Son of Bar-  
 achiah  
 cf Jehoash . . . . . 1576<sup>a</sup> (Caldecott)
- Zecher . . . . . 3140<sup>b</sup>  
 cf Zechariah (general) . 3135<sup>b</sup> (Easton)
- Zechrias . . . . . 3140<sup>b</sup>
- Zedad . . . . . 3140<sup>b</sup> (Christie)
- Zedechias . . . . . 3141<sup>a</sup>
- Zedekiah (general) . . . . 3141<sup>a</sup> (Lees)
- Zedekiah (king) . . . . . 3141<sup>a</sup> (Genung)  
 Downfall of Judah . . . 3142<sup>b</sup>  
 cf Jehoiachin . . . . . 1577<sup>a</sup> (Genung)  
 cf Jeremiah . . . . . 1588<sup>b</sup> (Orelli)  
 cf Pharaoh Hophra . . . 2359<sup>b</sup> (Nicol)  
 Rebellion and siege of  
 Jerusalem . . . . . 573<sup>b</sup> (Nicol)  
 Reign of . . . . . 3141<sup>b</sup>  
 Sources . . . . . 3141<sup>a</sup>
- Zeeb  
 cf Oreb and Zeeb . . . . 2201<sup>a</sup> (Roberts)
- Zela, Zelah . . . . . 3142<sup>b</sup>
- Zelek . . . . . 3143<sup>a</sup>
- Zelophehad . . . . . 3143<sup>a</sup> (Roberts)
- Zelotes  
 cf Simon, the Zealot . . 2797<sup>b</sup> (Kerr)  
 cf Zealot, Zealots . . . 3133<sup>b</sup> (Heidel)
- Zelzah . . . . . 3143<sup>a</sup> (Ewing)
- Zemaraim . . . . . 3143<sup>a</sup> (Ewing)
- Zemarite . . . . . 3143<sup>a</sup> (Ewing)
- Zemira (Zemirah) . . . . 3143<sup>b</sup>
- Zemirah . . . . . 3143<sup>b</sup>
- Zenan  
 cf Zaanan . . . . . 3128<sup>a</sup>
- Zenas . . . . . 3143<sup>b</sup> (Rutherford)
- Zend-avesta  
 cf Persian Religion . . . 2331<sup>b</sup> (Tisdall)  
 cf Zoroastrianism . . . . 3157<sup>a</sup> (Easton)
- Zephaniah (general) . . . . 3144<sup>a</sup> (N. Isaacs)  
 cf Zephaniah, Book of 3144<sup>a</sup> (Eiselen)
- Zephaniah, Apocalypse  
 of . . . . . 3144<sup>a</sup>
- Zephaniah, Book of . . . . 3144<sup>a</sup> (Eiselen)  
 Author . . . . . 3144<sup>a</sup>  
 Contents and integrity . . 3145<sup>b</sup>  
 Date . . . . . 3144<sup>b</sup>  
 cf Eschatology of OT . . 972<sup>a</sup> (Orr)  
 cf Scythians . . . . . 2706<sup>a</sup> (Porter)  
 Teaching . . . . . 3146<sup>a</sup>  
 cf Zephaniah (general) . 3144<sup>a</sup> (N. Isaacs)
- Zephath  
 cf Hormah . . . . . 1422<sup>a</sup> (Ewing)
- Zephathah, Valley of . . . 3146<sup>a</sup>
- Zephi, Zepho . . . . . 3146<sup>a</sup> (Roberts)
- Zephon  
 cf Ziphion . . . . . 3152<sup>b</sup>
- Zephonites . . . . . 3146<sup>b</sup>
- Zer . . . . . 3146<sup>b</sup>
- Zerah (general) . . . . . 3146<sup>b</sup> (Roberts)  
 cf Zohar . . . . . 3154<sup>b</sup>
- Zerah (The Ethiopian) . . 3146<sup>b</sup> (Cobern)  
 cf Zara . . . . . 3132<sup>a</sup>
- Zerahiah . . . . . 3147<sup>a</sup>
- Zerahites . . . . . 3147<sup>a</sup>
- Zered . . . . . 3147<sup>a</sup> (Ewing)  
 cf Willows, The Brook  
 of the . . . . . 3085<sup>b</sup>
- Zeredah, Zeredath, Zere-  
 datha, Zererah, Zere-  
 rath  
 cf Zarethana . . . . . 3133<sup>a</sup> (Wright)

- Zeresh . . . . . 3147<sup>a</sup>  
 Zereth . . . . . 3147<sup>b</sup>  
 Zereth-shahar . . . . . 3147<sup>b</sup>  
 Zeri . . . . . 3147<sup>b</sup>  
   cf Izri . . . . . 1545<sup>b</sup>  
 Zeror . . . . . 3147<sup>b</sup>  
   cf Zur . . . . . 3159<sup>a</sup>  
 Zeruah . . . . . 3147<sup>b</sup>  
 Zerubbabel . . . . . 3147<sup>b</sup> (R. D. Wilson)  
   cf Joshua (son of Jehoz-  
   adak) . . . . . 1748<sup>a</sup> (Roberts)  
   cf Sanabassar, Sana-  
   bassarus . . . . . 2681<sup>a</sup> (Angus)  
   cf Temple . . . . . 2936<sup>a</sup> (Caldecott; Orr)  
   cf Tirshatha . . . . . 2986<sup>b</sup> (R. D. Wilson)  
 Zeruah . . . . . 3148<sup>a</sup> (Roberts)  
   cf Abigail . . . . . 9<sup>b</sup> (Mack)  
 Zetham . . . . . 3148<sup>a</sup>  
 Zethan . . . . . 3148<sup>a</sup>  
 Zethar . . . . . 3148<sup>a</sup>  
 Zeus . . . . . 3148<sup>a</sup> (Angus)  
   cf Jupiter . . . . . 1781<sup>a</sup> (Easton)  
 Zia . . . . . 3148<sup>b</sup>  
 Ziba . . . . . 3148<sup>b</sup> (Roberts)  
 Zibeon . . . . . 3148<sup>b</sup>  
 Zibia . . . . . 3148<sup>b</sup>  
 Zibiah . . . . . 3148<sup>b</sup>  
 Zichri . . . . . 3149<sup>a</sup> (Roberts)  
   cf Zabdi . . . . . 3128<sup>b</sup> (Roberts)  
   cf Zechariah (general) 3135<sup>b</sup> (Easton)  
 Ziddim . . . . . 3149<sup>a</sup>  
 Zid-kijah  
   cf Zedekiah (general) 3141<sup>a</sup> (Lees)  
 Zidon, Zidonians  
   cf Sidon, Sidonians . . . 2785<sup>a</sup> (Porter)  
 Zif  
   cf Ziv . . . . . 3153<sup>a</sup>  
 Ziha . . . . . 3149<sup>a</sup>  
 Ziklag . . . . . 3149<sup>a</sup> (Masterman)  
   cf Negeb . . . . . 2130<sup>a</sup> (Masterman)  
 Zillah . . . . . 3149<sup>a</sup>  
 Zillethai . . . . . 3149<sup>b</sup>  
 Zilpah . . . . . 3149<sup>b</sup>  
 Zilthai  
   cf Zillethai . . . . . 3149<sup>b</sup>  
 Zimma . . . . . 3149<sup>b</sup>  
 Zimran . . . . . 3149<sup>b</sup> (Roberts)  
   cf Totemism . . . . . 3000<sup>a</sup> (M. O. Evans)  
   cf Zimri (general) . . . 3149<sup>b</sup> (Roberts)  
 Zimri (general) . . . . . 3149<sup>b</sup> (Roberts)  
   cf Baal-peor . . . . . 346<sup>b</sup> (Sayce)  
   cf Balaam . . . . . 378<sup>b</sup> (Baur)  
   cf Peor . . . . . 2319<sup>b</sup> (Ewing)  
   cf Zabdi . . . . . 3128<sup>b</sup> (Roberts)  
   cf Zimran . . . . . 3149<sup>b</sup> (Roberts)  
 Zimri (king) . . . . . 3150<sup>a</sup> (Mosiman)  
 Zin . . . . . 3150<sup>a</sup> (Ewing)  
 Zina  
   cf Zizah . . . . . 3153<sup>a</sup>  
 Zion . . . . . 3150<sup>b</sup> (Masterman)  
   cf Gezer . . . . . 1224<sup>a</sup> (Masterman)  
   cf Gihon . . . . . 1228<sup>b</sup> (Masterman)  
 Zion—*continued*  
   Jebusite city . . . . . 3150<sup>b</sup>  
   cf Jerusalem . . . . . 1601<sup>b</sup> (Masterman)  
   cf Ophel . . . . . 2196<sup>b</sup> (Masterman)  
   Prophetic references . . 3151<sup>b</sup>  
   cf Sion . . . . . 2806<sup>a</sup>  
 Zior . . . . . 3152<sup>b</sup>  
 Ziph (person) . . . . . 3152<sup>b</sup>  
 Ziph (place) . . . . . 3152<sup>b</sup> (Masterman)  
 Ziphah . . . . . 3152<sup>b</sup>  
 Ziphims  
   cf Ziph (place) . . . . . 3152<sup>b</sup> (Masterman)  
 Ziphion . . . . . 3152<sup>b</sup>  
   cf Zaphon . . . . . 3132<sup>a</sup> (Ewing)  
   cf Zephonites . . . . . 3146<sup>b</sup>  
 Ziphites  
   cf Ziph (place) . . . . . 3152<sup>b</sup> (Masterman)  
 Ziphron  
   cf Sibraim . . . . . 2783<sup>a</sup>  
 Zippor . . . . . 3152<sup>b</sup>  
 Zipporah . . . . . 3152<sup>b</sup> (Kyle)  
   cf Shiphrah . . . . . 2774<sup>a</sup>  
 Zithri  
   cf Sithri . . . . . 2813<sup>a</sup>  
 Ziv . . . . . 3153<sup>a</sup>  
   cf Calendar . . . . . 541<sup>b</sup> (Porter)  
 Ziz, Ascent of . . . . . 3153<sup>a</sup>  
 Ziza . . . . . 3153<sup>a</sup>  
 Zizah . . . . . 3153<sup>a</sup>  
 Zizath  
   cf Ziza . . . . . 3153<sup>a</sup>  
 Zoan . . . . . 3153<sup>a</sup> (Conder)  
   cf Goshen . . . . . 1280<sup>a</sup> (Conder)  
   cf Hittites . . . . . 1395<sup>b</sup> (Conder)  
   Location . . . . . 3153<sup>a</sup>  
   Monumental data . . . . 3153<sup>b</sup>  
   cf Pithom . . . . . 2401<sup>b</sup> (Conder)  
   cf Raamses . . . . . 2520<sup>a</sup> (Conder)  
 Zoar . . . . . 3154<sup>a</sup> (Wright)  
   cf Dead Sea . . . . . 801<sup>a</sup> (Wright)  
 Zobah . . . . . 3154<sup>b</sup> (Christie)  
   cf Syria . . . . . 2880<sup>b</sup> (Christie)  
 Zobebah . . . . . 3154<sup>b</sup>  
 Zodiac, Signs of . . . . . 312<sup>b</sup>  
 Zodiacal Tablet  
   cf Palestine, Recent  
   Exploration . . . . . 2233<sup>b</sup> (Cobern)  
 Zohar . . . . . 3154<sup>b</sup>  
   cf Zerah (general) . . . 3146<sup>b</sup> (Roberts)  
 Zohelath, Stone of . . . . 3155<sup>a</sup> (Masterman)  
 Zoheth . . . . . 3155<sup>a</sup>  
   cf Benzoheth . . . . . 439<sup>a</sup>  
 Zoölogy . . . . . 3155<sup>a</sup> (Day)  
   cf Gazelle . . . . . 1179<sup>a</sup> (Day)  
   cf Goat . . . . . 1248<sup>b</sup> (Day)  
   cf Jackal . . . . . 1548<sup>a</sup> (Day)  
   cf Pygarg . . . . . 2511<sup>a</sup> (Day)  
 Zophah . . . . . 3156<sup>b</sup>  
 Zophai . . . . . 3156<sup>b</sup>  
   cf Zuph . . . . . 3158<sup>b</sup> (Roberts)  
 Zophar . . . . . 3156<sup>b</sup> (Genung)  
   cf Bildad . . . . . 473<sup>b</sup> (Genung)

- Zophim, Field of . . . . . 3157<sup>a</sup>  
 Zorah . . . . . 3157<sup>a</sup> (Masterman)  
 Zorathites . . . . . 3157<sup>a</sup>  
 Zoreah . . . . . 3157<sup>a</sup>  
   cf Zorah . . . . . 3157<sup>a</sup> (Masterman)  
 Zorites . . . . . 3157<sup>a</sup>  
   cf Manahath . . . . . 1976<sup>b</sup> (Ewing)  
   cf Zorathites . . . . . 3157<sup>a</sup>  
 Zoroaster  
   cf Persian Language  
     and Literature . . . . . 2330<sup>b</sup> (Tisdall)  
 Zoroastrianism . . . . . 3157<sup>a</sup> (Easton)  
   cf Antichrist . . . . . 154<sup>a</sup> (J. E. H. Thomson)  
   cf Astrology . . . . . 295<sup>b</sup> (Maunder)  
   cf Branch . . . . . 513<sup>b</sup> (Masterman)  
   cf Exorcism . . . . . 1067<sup>b</sup> (Sweet)  
   cf God . . . . . 1250<sup>a</sup> (Rees)  
   History . . . . . 3157<sup>b</sup>  
   cf Magi, The . . . . . 1962<sup>a</sup> (Tisdall)  
   cf Messiah . . . . . 2039<sup>a</sup> (Crichton)  
   cf Parousia . . . . . 2249<sup>a</sup> (Easton)  
   cf Persian Religion  
     (Ancient) . . . . . 2334<sup>b</sup> (Tisdall)
- Zoroastrianism—*continued*  
   cf Rab-mag . . . . . 2522<sup>a</sup> (Clippinger)  
   Relation to Israel . . . . . 3157<sup>b</sup>  
   cf Resurrection . . . . . 2565<sup>a</sup> (Easton)  
   cf Salvation . . . . . 2665<sup>a</sup> (Easton)  
   cf Satan . . . . . 2696<sup>a</sup> (Sweet)  
   cf Son of Man . . . . . 2828<sup>b</sup> (Stalker)  
   Special features . . . . . 3158<sup>a</sup>  
 Zorobabel . . . . . 3158<sup>b</sup>  
 Zorzelleus . . . . . 3158<sup>b</sup>  
   cf Barzillai . . . . . 410<sup>b</sup> (Rees)  
 Zuar . . . . . 3158<sup>b</sup>  
 Zuph . . . . . 3158<sup>b</sup> (Roberts)  
   cf Zophai . . . . . 3156<sup>b</sup>  
 Zur . . . . . 3159<sup>a</sup>  
   cf Zeror . . . . . 3147<sup>b</sup>  
 Zuriel . . . . . 3159<sup>a</sup> (Roberts)  
 Zurishaddai . . . . . 3159<sup>b</sup>  
   cf God, Names of . . . . . 1264<sup>b</sup> (Mack)  
   cf Zuriel . . . . . 3159<sup>a</sup> (Roberts)  
 Zuzim . . . . . 3159<sup>b</sup>  
 Zwingli  
   cf Lord's Supper . . . . . 1926<sup>a</sup> (Dosker)

# INDEX OF SCRIPTURE TEXTS

NOTE.—The following illustrates the method of arranging this Index: 315 (3)=reference will be found on page 315 near box heading 3. 145<sup>b</sup>=right-hand column. 148=left-hand column. 1095<sup>a</sup>=the reference is found twice on page 1095.

<p style="text-align: center;">GEN 1</p> <p>1—146 (III); 1046; 1915                  2—3074                  3—1411                  6—315 (3)                  9—316 (7)                  14—302; 3108                  16—299<sup>b</sup>                  21—150 (5)                  26—49; 51 (3); 1046 (2); 1270 (1);                      1407; 1450 (b); 3014 (5)                  27—1095 (2); 1406 (b); 1460                  28—145                  31—2633 (3)</p> <p style="text-align: center;">GEN 2</p> <p>2—2632 (1)                  4—146 (b)                  7—49; 973 (2)<sup>a</sup>; 989<sup>a</sup>; 2495 (2)                  8—147(3)                  9—51 (5); 420; 3009                  14—152                  16—51 (4); 1463 (1); 2575 (1)                  17—51 (5); 811 (1); 1460; 2498                      (10)                  18—51 (3); 1040; 2416                  21—3100                  23—1095                  25—1040<sup>b</sup>; 2111</p> <p style="text-align: center;">GEN 3</p> <p>1—492 (5); 828; 2696 (4);                      2798 (4)                  3—51 (5)                  5—3089 (2)                  6—51 (5); 3101 (7)                  7—2111<sup>b</sup>                  8—603<sup>b</sup>; 703; 1128; 2574; 2575                      (2)                  14—309 (3)                  15—52 (6); 477 (2); 620<sup>b</sup>; 1281;                      1353 (4); 1367                  16—1040 (1); 1463; 3100                  18—1095                  19—515; 811 (1)                  22—51 (5); 52 (6); 3009 (1);                      3014 (5)                  24—308<sup>b</sup></p> <p style="text-align: center;">GEN 4</p> <p>1—477 (2)                  3—3110<sup>b</sup>                  4—1460 (3); 2640 (1); 2642 (4)</p>	<p style="text-align: center;">GEN 4—continued</p> <p>7—5                  8—539                  9—1887 (4)                  10—489 (2); 703                  12—1042 (2)                  13—2570 (4)                  15—657 (2); 2393; 3124                  19—1095 (4)                  23—1823<sup>b</sup>                  24—2504<sup>b</sup></p> <p style="text-align: center;">GEN 5</p> <p>2—52 (6); 146 (b)                  24—975 (1); 1460 (II)<sup>a</sup>                  29—1824</p> <p style="text-align: center;">GEN 6</p> <p>1—608 (1)                  2—145; 2835                  4—143<sup>b</sup>; 2133<sup>b</sup>                  5—2798 (2)                  6—2558; 3034 (1)                  7—1467 (4)                  8—1460 (3)                  9—2799 (5)                  11—722<sup>b</sup>; 2800 (8)                  12—1042 (2)                  17—973 (2)</p> <p style="text-align: center;">GEN 8</p> <p>20—1484 (1); 2019; 2444 (2);                      2642 (4)                  21—1534 (6); 2575 (2); 2700<sup>b</sup></p> <p style="text-align: center;">GEN 9</p> <p>1—2575 (2)                  6—146 (3)                  12—3124 (3)                  13—309; 2527; 2789<sup>b</sup>                  22—2112                  23—877<sup>b</sup>                  26—435                  27—1376 (2)</p> <p style="text-align: center;">GEN 10</p> <p>5—2899 (2)                  9—1440 (1)                  10—312 (11); 359 (3); 574 (16);                      590 (12)                  11—2148 (5)                  19—2304 (4)                  21—1513 (2)                  22—918; 2305 (2)</p>	<p style="text-align: center;">GEN 11</p> <p>1—2995<sup>a</sup>                  3—521; 2817<sup>b</sup>                  5—1128; 1467 (4); 1533<sup>b</sup>                  6—1129<sup>b</sup>                  7—3014 (5)                  10—140                  31—910 (2); 1929<sup>b</sup></p> <p style="text-align: center;">GEN 12</p> <p>1—973 (1)                  3—458 (4); 1022 (b); 1212 (2);                      1460 (3); 2517<sup>b</sup>; 2574                  6—2303                  7—2019; 2642 (6)</p> <p style="text-align: center;">GEN 13</p> <p>2—2076 (1)                  4—2642 (6)                  8—1930<sup>b</sup>                  10—807 (1)                  15—2519<sup>b</sup></p> <p style="text-align: center;">GEN 14</p> <p>1—119; 126; 327 (7); 365; 550                      (3); 919                  3—809                  6—2232 (a)                  15—2168 (4)                  18—1267 (3); 3088 (2)                  22—2028</p> <p style="text-align: center;">GEN 15</p> <p>4—2642 (6)                  5—306                  6—2517                  9—727 (2); 732 (6)                  13—911 (6); 1128<sup>b</sup>; 1515                  15—2725 (1)                  16—764                  17—1533 (b)</p> <p style="text-align: center;">GEN 16</p> <p>1—1331 (1)                  3—2300 (3); 2302 (3)                  5—504                  6—2690<sup>b</sup>                  7—2021                  12—1510 (5)                  13—1267 (5)</p> <p style="text-align: center;">GEN 17</p> <p>4—2574                  6—1800 (3)                  8—2519<sup>b</sup></p>
---	--	---

GEN 17—*continued*

10—489; 1534 (b)  
17—2117<sup>b</sup>  
18—1509<sup>b</sup>  
25—2302<sup>b</sup>

## GEN 18

1—1022 (b); 1432 (2)  
4—414<sup>b</sup>; 1125  
5—1351 (2)  
6—516 (6)  
12—2117<sup>b</sup>  
14—2189 (4)  
18—458 (4); 2574  
19—583  
21—1467 (4)  
22—2019  
25—972 (1); 1534; 2592 (3)  
27—269  
32—972 (b)

## GEN 19

2—414<sup>b</sup>  
8—1432 (4); 2556<sup>b</sup>  
28—3046

## GEN 20

3—861 (i)  
7—2461<sup>b</sup>  
16—488 (b)

## GEN 21

8—1316 (3)  
9—1168 (b); 1509 (3)  
10—478; 2690<sup>b</sup>  
14—2300 (3); 2302 (3)  
19—510<sup>b</sup>  
21—1376 (2)  
23—1011 (2); 3034

## GEN 22

2—2642 (6)  
12—1113  
14—1583  
18—620 (VI); 2574

## GEN 23

1—2304  
8—533 (2)  
16—2081

## GEN 24

26—3110 (2)  
31—1819  
40—20  
53—1331<sup>b</sup>  
60—487 (3)  
67—2691<sup>b</sup>

## GEN 25

8—974 (4)  
19—2554 (1)  
23—1114  
26—2302<sup>b</sup>  
30—144<sup>b</sup>  
31—2453 (3)

GEN 25—*continued*

32—1550 (b)  
34—1866<sup>b</sup>

## GEN 26

25—2642 (8)  
34—2300 (3)  
35—2556<sup>b</sup>

## GEN 27

4—487  
12—971<sup>b</sup>  
13—2912  
27—435  
41—2302<sup>b</sup>  
46—2300 (3)

## GEN 28

10—1637  
13—1553 (3)  
16—1531 (b)  
18—1454 (5); 2642 (9); 3124 (3)  
20—2430<sup>b</sup>  
21—2302 (2)

## GEN 29

17—487  
31—1933 (b)

## GEN 30

1—1331 (1)  
6—2523 (2)  
20—1861 (b)  
37—100 (b)

## GEN 31

7—1550<sup>b</sup>  
19—1532 (b); 1551  
46—107<sup>b</sup>  
53—1442

## GEN 32

9—1442  
13—2918<sup>b</sup>  
24—1551  
30—1316 (2)

## GEN 33

10—2918<sup>b</sup>

## GEN 34

1—1551 (b)  
3—1868<sup>b</sup>  
25—2793 (1)

## GEN 35

2—1532<sup>b</sup>; 2523 (2)  
5—1551 (b)  
22—2416<sup>b</sup>  
28—2302<sup>b</sup>

## GEN 36

31—2303

## GEN 37

2—1738<sup>b</sup>  
3—878 (3)  
9—310 (6)  
27—2301  
28—2416<sup>b</sup>

## GEN 38

15—2211 (4)  
18—498 (b); 735 (3); 2708 (1)  
21—2682 (1)  
24—2305 (3)

## GEN 39

20—1739

## GEN 40

16—413  
17—516 (5)

## GEN 41

14—403 (2)  
25—1739 (4)  
41—2708 (2)  
43—911  
45—913 (23); 3132  
50—2444 (3)  
54—824 (11)

## GEN 42

21—2504<sup>b</sup>  
22—2571 (1)  
23—2210 (1)  
37—2305 (3)

## GEN 43

11—100 (4); 2918<sup>b</sup>  
21—535  
34—880 (b)

## GEN 44

3—331 (2)  
20—438 (1)

## GEN 45

13—1236

## GEN 46

4—529 (4)  
34—1739 (3)

## GEN 47

4.27—911 (5,9)  
11—1054; 2520<sup>s</sup>  
18—1738

## GEN 48

5—2556<sup>b</sup>  
8—598 (2)  
13—1334

## GEN 49

1—1552  
3—1376 (2); 2453 (3); 2572 (1)  
4—310  
6—1236<sup>b</sup>  
10—620 (VI); 1858<sup>b</sup>; 2768<sup>b</sup>  
12—2052  
18—1553 (3)

## GEN 50

2—530; 974 (4)  
3—911 (5)  
5—976 (1)



GEN 50—*continued*

17—1133 (2)  
20—2484 (6)  
26—911 (6)

## Ex 1

1—1055  
8—3154  
11—520; 1064; 2086; 2539<sup>b</sup>  
15—2166<sup>b</sup>  
16—2862<sup>b</sup>

## Ex 2

3—242; 736 (13); 2084 (2);  
2817<sup>b</sup>  
5—1053 (3); 2360<sup>b</sup>  
10—2084 (2)<sup>2</sup>  
15—2085

## Ex 3

2—532<sup>2</sup>  
5—404 (2); 1125 (b)  
8—76  
10—2085 (5)  
13—1088 (1); 1266 (5); 3034  
14—1254<sup>b</sup>; 1535  
18—2643  
19—1128<sup>b</sup>; 1129<sup>b</sup>

## Ex 4

4—2449<sup>b</sup>  
6—1867  
10—1067 (2)  
11—2093  
19—2085<sup>b</sup>  
22—609 (5); 1515 (b); 2403<sup>b</sup>;  
2826 (2)  
24—2912  
25—490; 657

## Ex 5

3—2643  
6—1883 (9)  
21—2700<sup>b</sup>; 2818

## Ex 6

3—1535; 2300 (2)  
7—2039<sup>b</sup>  
12—1067 (2)  
30—657 (4)

## Ex 7

4—1128<sup>b</sup>  
11—942 (1)  
16—2643  
19—524 (3); 2311 (6)

## Ex 8

9—1239 (3)  
15—1338  
18—942 (1)  
19—1111<sup>b</sup>  
22—2477 (1)  
24—1120

## Ex 9

1—2405 (5)  
3—2094<sup>b</sup>  
16—2406<sup>b</sup>  
27—2559

## Ex 10

7—2406 (1); 2819<sup>b</sup>  
8—2643  
23—1891  
24—2405 (9)

## Ex 11

1—1128<sup>b</sup>  
2—1257  
3—1067 (2)

## Ex 12

2—541  
6—1103 (2)  
7—1929 (2)  
21—2022<sup>b</sup>; 2257<sup>b</sup>  
34—877<sup>b</sup>  
36—2086  
37—1056; 1065 (5); 2539<sup>b</sup>  
41—1055  
43—1853 (b)  
48—656<sup>b</sup>

## Ex 13

2—1114; 2453 (4); 2682 (1)  
6—2257 (7)  
7—2167  
9—127<sup>b</sup>; 2393 (3)  
14—2532 (b)  
19—976 (1); 2591<sup>b</sup>

## Ex 14

2—913<sup>b</sup>; 2050; 2086<sup>b</sup>; 2396 (1)  
19—395  
21—2539 (4); 2540<sup>2</sup>

## Ex 15

4—2086<sup>b</sup>  
8—2540; 2841 (1)  
11—1535<sup>b</sup>; 2682 (1)  
18—1800 (1)  
27—2087 (5)

## Ex 16

1—2087 (5)  
12—2015 (3)  
13—2301 (4)  
14—1147<sup>b</sup>  
22—2632<sup>b</sup>  
27—2634

## Ex 17

2—2943  
7—2301<sup>b</sup>; 2303 (4)  
8—1066 (1)  
11—912  
14—2169

## Ex 18

11—1535  
12—108; 1674 (3); 2643 (11)

Ex 18—*continued*

21—1287<sup>b</sup>; 1675 (5)  
26—208

## Ex 19

4—885<sup>b</sup>; 1858; 2643 (1)  
5—1922 (3); 2682 (1)  
6—1800 (1); 2439  
8—2019 (3)  
15—1003 (7)  
16—2997 (2)

## Ex 20

1—26; 1020 (a); 1332 (1); 2090<sup>b</sup>  
2—2065  
3—202  
4—1535 (4)  
5—1376; 1858  
6—1933 (2); 2946 (4)  
8—2632<sup>b</sup>  
10—2469 (4)  
12—1095 (5); 2944 (1)  
13—2667 (5)  
17—733<sup>b</sup>  
20—110  
22—2201  
24—109; 839 (7); 1539; 2643 (2);  
2644 (7); 2897<sup>b</sup>  
25—110 (1)

## Ex 21

2—1331 (1); 2635 (2)  
6—341; 1270 (2); 2301 (5)  
7—863  
8—2555<sup>b</sup>  
12—2305 (3)  
15—1331 (1)  
20—764  
22—1418  
25—2455<sup>b</sup>

## Ex 22

7.10—1332 (1)  
18—1964  
20—1858  
26—2409; 2917<sup>b</sup>  
27—421<sup>b</sup>; 877 (b)

## Ex 23

10—74 (1)  
11—2090<sup>b</sup>; 2635  
14—542; 1255 (ii)  
16—3024 (2)  
19—2052<sup>b</sup>  
29—2147<sup>b</sup>  
32—764; 3008<sup>b</sup>

## Ex 24

3—1858; 2653 (2); 2655 (1)  
4—108; 463 (1b); 2643 (1)  
6—2846<sup>b</sup>  
7—556; 731 (3)  
8—2022; 2025; 2668<sup>b</sup>  
17—2802<sup>b</sup>

Ex 25	Ex 34	LEV 11— <i>continued</i>
5—2814	5—1237	35—2530
8—883 <sup>b</sup> ; 1079	8—3110 (2)	44—1404
9—234 (1); 2264 <sup>b</sup>	9—2129	LEV 13
22—1852 (2); 2303	12—3008 <sup>b</sup>	10—2515 <sup>b</sup>
33—100 (b)	17—244	13—1867 (3)
Ex 27	18—2257 <sup>b</sup>	45—1896
9—234 (2)	22—3024 (2)	47—2449
20—2181 <sup>b</sup> ; 2182	26—2052	LEV 14
Ex 28	29—3005 <sup>b</sup>	14—886 (1)
1—2440 (1); 2444 (3)	Ex 35	33—2449
3—2841 (1)	25—736' (16); 2841	34—1868 (2)
4—962	35—3077 <sup>b</sup>	LEV 15
12—2439; 2445 (2)	Ex 38	11—14
20—3041 (3)	8—2894	18—1003
29—2020	Ex 39	LEV 16
30—2019 (4)	2—962	1—327
31—2442 (3)	Ex 40	2—671 (9); 1079
36—2900 <sup>b</sup>	26—111(1)	4—326 <sup>b</sup>
40—495 (b)	34—1079	12—112 (2)
Ex 29	LEV 1	21—828
1—2643 (3)	2—1857	29—327
2—515 <sup>2</sup>	3—2644 (5)	33—326 <sup>b</sup>
9—495 (b)	14—476	LEV 17
18—2818	LEV 2	3—758
20—2441	4—516 (3)	7—828
44—2682 (1)	14—2247 <sup>b</sup>	10—1857
45—1079	LEV 3	LEV 18
Ex 30	11—1857	19—2111 <sup>b</sup>
6—245	LEV 4	21—2074 (2)
9—112	1—2645 (c)	LEV 19
11—322 (1); 2080 <sup>b</sup>	3—2439 (2)	2—1404 <sup>2</sup>
12—2022; 2531	LEV 5	15—488 (b)
16—2918 (2)	1—2666 (5)	17—1351 (2)
35—736 (14)	17—1309	18—1022 (b); 1029; 2133 <sup>2</sup>
Ex 31	LEV 6	19—2712 <sup>b</sup>
18—1111 <sup>b</sup>	1—2666 (5)	23—657 (4)
Ex 32	LEV 7	26—2466 (1)
1—2643 (4)	12—1857	27—1320 (2)
2—127 (1)	38—1870 (2)	28—657; 1127 (b); 2455 <sup>b</sup>
5—544 (5)	LEV 8	31—944
7—722 <sup>b</sup>	8—2019 (b)	LEV 20
9—2129; 2854	9—2900 <sup>b</sup>	2—2074; 2390
12—2019 <sup>b</sup>	10—343 (2)	6—2466 (1)
14—2727 (11)	23—886 (1)	10—1096 (8); 2508 (1)
26—2449 <sup>b</sup>	26—516	22—2592 (3)
29—1333	LEV 9	27—690 (2)
30—2019 <sup>b</sup>	22—2440 (4)	LEV 21
32—2310 <sup>b</sup>	LEV 10	5—380 <sup>b2</sup> ; 1320 (4)
Ex 33	1—10; 2682 <sup>b</sup>	18—2156
1—2665 <sup>b</sup>	4—529	LEV 22
3—2129 <sup>b</sup>	9—881; 2864 <sup>b</sup>	10—2556 (4)
4—2202	LEV 11	LEV 23
7—2303; 2449 (III)	4—2864	5—1103
11—2462	5—1339	8—2257
18—1237	13—885 <sup>b</sup>	10.23—1103
20—1316 <sup>b</sup> ; 2723 (3)		14—2247 <sup>b</sup>

LEV 23—continued

15—2257 (7)  
34—1854  
40—2236 (3)

LEV 24

11—3017<sup>b</sup>  
14—2853 (6)  
16—1858  
19—2504<sup>b</sup>

LEV 25

1—1870  
2—2635<sup>b</sup>  
6—74 (1)  
8—542  
9—305 (4)  
12—74 (2)  
15—1756 (2)  
18—1757  
23—1468<sup>b</sup>  
25—2427 (4)  
26—2541  
32—757<sup>b</sup>  
34—75 (7)  
39—2301 (5)  
47—1272  
48—2555 (3)  
51—2022

LEV 26

1—1454 (b)  
4—505 (3); 2526 (3)  
5—3051  
11—2837<sup>b</sup>  
16—78; 487  
22—2147<sup>b</sup>  
23—2545<sup>b</sup>  
31—2818  
34—2635 (4)  
38—2164 (ii)  
41—1079  
42—75 (6)  
46—2023; 1870

LEV 27

14—2682 (1)  
16—75 (4)  
17—1756 (2)  
31—2530<sup>b</sup>  
34—1870

NU 1

18—2295  
20—610<sup>b</sup>

NU 3

11—1113<sup>b</sup>  
12—2682 (1)  
40—2531<sup>2</sup>  
43—2167<sup>b</sup>  
51—2022; 2541

NU 4

8—2814  
19—2019 (4)

NU 5

11—1572; 2169<sup>b</sup>; 2591<sup>b</sup>  
14—2842

NU 6

1—1320 (3); 2124<sup>b</sup>  
3—881  
18—2645  
22—2440 (4)  
23—1913 (2)

NU 8

5—390<sup>b</sup>  
7—2169<sup>b</sup>  
19—2020

NU 9

1—2166 (1)

NU 10

3—2168  
10—1103 (1)  
14—2168 (3)  
35—245; 2190 (5)

NU 11

1—3034 (1)  
5—1514 (3); 2311 (6)  
10—3113 (1)  
25—2842

NU 12

1—769; 2556; 3152<sup>b</sup>  
3—2090  
6—2462; 2577 (1); 2578 (3);  
2581<sup>b</sup>  
8—1237

NU 13

22—2169<sup>b</sup>  
23—1123  
28—662 (2)  
29—120  
33—84; 143 (3)

NU 14

18—1021 (a)  
20—322  
29—323  
42—243 (b)  
45—2302<sup>b</sup>

NU 15

30—1292 (3); 2651; 2666 (5)  
32—2169  
37—2917<sup>b</sup>

NU 16

3—2019 (4)  
10—839  
22—2497 (4)

NU 17

2—244 (4)  
10—3116

NU 18

2—1868 (b)  
3—2307<sup>b</sup>; 2448 (1)

NU 18—continued

6—2020  
19—2556<sup>b</sup>  
21—757  
30—76 (b)

NU 19

3—2169<sup>b</sup>  
8—390<sup>b</sup>  
11—2169<sup>b</sup>  
14—1533

NU 20

1—2166; 2303 (4)  
5—2169  
11—2843  
12—2682<sup>b</sup>  
22—1421 (3)  
28—2300 (b)

NU 21

8—1455 (6)  
9—2789<sup>b</sup>  
14—2169  
17—2830<sup>b</sup>  
27—120; 2470  
29—1255

NU 22

5—293 (b)  
34—2559 (2)

NU 23

5—378 (2)  
10—975; 1623  
13—2168 (2)  
19—2337<sup>b</sup>; 3034 (3)  
22—3085  
23—2466 (2)

NU 24

2—310 (8); 378 (2); 2460 (2)  
5—103  
7—311 (9); 2169  
8—3085  
17—308; 629 (3); 2702; 2848 (5)  
21—2138<sup>b</sup>

NU 25

1—2778 (1)

NU 27

8—526; 2554 (1)  
14—2682<sup>b</sup>  
16—2495 (4); 2497 (4)  
17—2763<sup>b</sup>

NU 28

19—2257 (7)

NU 29

7—322 (3)

NU 31

16—1770  
49—2168 (4)

NU 32

10—322 (b)

<p>N<sup>U</sup> 33</p> <p>2—2164 (2) 7—2050 38—2; 2300 (3); 2302<sup>b</sup> 55—2974</p>	<p>D<sup>T</sup> 11—<i>continued</i></p> <p>14—505 (3) 16—202 20—2900<sup>b</sup></p>	<p>D<sup>T</sup> 20</p> <p>1—256 (6) 10—764 16—35; 1536; 2306 (8)</p>
<p>N<sup>U</sup> 35</p> <p>5—2634<sup>b</sup> 19—764; 2555 (3) 31—2697 32—2546 (3) 33—322 (b)</p>	<p>D<sup>T</sup> 12</p> <p>3—2212 5—1265 6—2897<sup>b</sup> 8—2167 (3) 10—838; 839<sup>b</sup> 23—2837<sup>b</sup> 30—764</p>	<p>D<sup>T</sup> 21</p> <p>1—2651 9—2645 (IV) 12—418 (6) 15—478 (b) 17—2453 22—1662 (1) 23—2567 (4)</p>
<p>D<sup>T</sup> 1</p> <p>28—234 (b); 550 (2); 662 (2)</p>	<p>D<sup>T</sup> 13</p> <p>1—875 17—3034 (1)</p>	<p>D<sup>T</sup> 22</p> <p>6—2138<sup>b</sup> 9—2712<sup>b</sup> 12—2917<sup>b</sup> 19—864 (4) 22—2508 (1) 23—1998</p>
<p>D<sup>T</sup> 4</p> <p>7—2574 19—2081<sup>b</sup>; 2514 30—2558<sup>b</sup> 32—2065; 2311 (5)</p>	<p>D<sup>T</sup> 14</p> <p>1—380<sup>b</sup> 2—2294<sup>b</sup> 12—885<sup>b</sup> 21—2052 22—757 28—2427 (4)</p>	<p>D<sup>T</sup> 23</p> <p>15—1856 18—271 (b); 2682 (1) 19—1257; 2133</p>
<p>D<sup>T</sup> 5</p> <p>1—1020 (a); 2168 (2) 15—2944 (I) 16—747 18—1095<sup>b</sup> 24—1237 (4)</p>	<p>D<sup>T</sup> 15</p> <p>1—2635 (2) 4—2420 11—101 (b) 12—2427 (4); 2666 (4) 15—2541 17—341</p>	<p>D<sup>T</sup> 24</p> <p>1—864 (b); 2592 (3) 12—2409 13—421<sup>b</sup> 14—1022 16—36; 838; 2665 (2) 20—2181<sup>b</sup>; 2185 (2)<sup>2</sup></p>
<p>D<sup>T</sup> 6</p> <p>4—741; 1088; 1933 5—1029 6—2303 7—2104 (2) 8—127<sup>b</sup> 9—2900<sup>b</sup> 14—202 16—2301<sup>b</sup> 25—2591<sup>b</sup></p>	<p>D<sup>T</sup> 16</p> <p>1—542 8—2257 (7) 18—726 19—488 (b) 21—108 (b); 2643 (2) 22—2234; 1454<sup>b</sup></p>	<p>D<sup>T</sup> 25</p> <p>2—1856 4—1022; 1367<sup>b</sup>; 2102 5—526 9—1125 (b); 2779<sup>b</sup></p>
<p>D<sup>T</sup> 7</p> <p>2—1536; 3008<sup>b</sup> 3—1129<sup>b</sup> 6—613 (4); 1922 (3) 24—2112 25—2942<sup>b</sup></p>	<p>D<sup>T</sup> 17</p> <p>2—1858 3—2514<sup>b</sup> 7—2853 (6) 8—208 14—1800 (3); 2306 16—1423 (3)</p>	<p>D<sup>T</sup> 26</p> <p>12—2427 (4)</p> <p>D<sup>T</sup> 27</p> <p>5—839<sup>b</sup>; 2896 (4) 11—890</p>
<p>D<sup>T</sup> 8</p> <p>3—2943<sup>b</sup> 4—1125 (b) 9—2044<sup>b</sup></p>	<p>D<sup>T</sup> 18</p> <p>6—2449<sup>b</sup>; 2450 8—2264 9—296; 942; 944 10—1963 (b); 2466 (1); 3098 11—2761<sup>b</sup> 15—617 (III); 2022; 2040<sup>b</sup>; 2462 (3); 2517<sup>b</sup>; 2578 (3); 2921 (8) 18—2093; 2578 21—2461</p>	<p>D<sup>T</sup> 28</p> <p>1—973 (1); 2665 13—2903<sup>b</sup> 22—486<sup>b</sup> 27—301 (d) 28—1961 (1) 35—1104 37—2470 (3) 49—885<sup>b</sup> 58—3017<sup>b</sup> 59—1376</p>
<p>D<sup>T</sup> 9</p> <p>2—84 (b) 6—2854 10—1111<sup>b</sup></p>	<p>D<sup>T</sup> 19</p> <p>1—2546 (3) 6—2555 (3) 14—2212 15—1670 (1)</p>	<p>D<sup>T</sup> 29</p> <p>2—2168 (2) 5—837 23—522<sup>bc</sup> 27—3113 (1) 29—2104 (2); 2312</p>
<p>D<sup>T</sup> 10</p> <p>6—2300 (b) 12—1933 (2) 16—657<sup>b</sup></p> <p>D<sup>T</sup> 11</p> <p>8—973 (1) 10—1126; 1493 11—2525<sup>b</sup></p>		

DT 30	JOSH 9	JGS 8
6—657 (3)	4—510 <sup>b</sup>	2—1234 <sup>b</sup>
11—2666 (4)	23—1226	14—463 (c)
DT 31	JOSH 10	22—1517 <sup>b</sup>
9—463; 555 <sup>b</sup> ; 836 (6)	12—448 (3)	23—2965 <sup>b</sup>
10—2635 (3)	24—1126; 2129	24—1777; 2918 <sup>b</sup>
19—2093	33—2232 (d)	25—877 <sup>b</sup>
22—840	JOSH 11	27—675; 1456 <sup>2</sup>
24—1854 (4)	1—1750 (b)	JGS 9
26—1886 (14)	21—2229 (2)	7—29 (III); 1085; 1754
DT 32	JOSH 13	8—2184 <sup>b</sup> ; 2243 (1)
2—505	3—2768	9—1534 (6)
4—1266 (b)	5—3000 <sup>b</sup>	13—3088 (2)
6—608 (2); 3089 (2)	JOSH 15	37—2033
7—2310 (3)	44—2227	53—2052
11—885 <sup>b</sup>	JOSH 16	JGS 10
13—2184 <sup>b</sup>	10—1223 <sup>b</sup> ; 2232 (d)	1—884 <sup>b</sup> ; 1775
14—1796 <sup>b</sup>	JOSH 17	JGS 11
15—1623; 3035 (5)	14—506 (b)	24—1255 (a)
22—978; 2761 <sup>b</sup>	JOSH 18	30—1256
34—2709	7—2450	34—1777
DT 33	10—1884 (11)	39—1587
2—2998	JOSH 20	JGS 14
3—1125 <sup>b</sup>	3—2555	6—2842
12—2780 <sup>b</sup>	JOSH 22	18—240 <sup>b</sup> ; 1367 <sup>b</sup>
16—532 <sup>2</sup>	9—108 <sup>b</sup>	JGS 15
19—735	29—838	3—212
21—1859	JOSH 24	8—1394 <sup>b</sup>
27—975; 1011 (2); 1460 (3); 3037	14—1514 <sup>b</sup>	15—600; 2168 (4)
DT 34	26—2089 (1); 2920 (2)	JGS 16
7—911 (7)	JGS 1	4—2676
10—2462; 2577 (2); 2578 (3)	1—3040 <sup>b</sup>	21—2456 (6)
JOSH 2	JGS 2	31—1518
1—2525	2—3008 <sup>b</sup>	JGS 17
16—2212 <sup>b</sup>	7—1427	6—1776
JOSH 3	JGS 4	7—2449 <sup>b</sup>
15—1745 (2); 2212 (2)	8—3100 <sup>b</sup>	13—2450
JOSH 4	18—1557 <sup>b</sup> ; 2556 <sup>b</sup>	JGS 18
3—1745 (b)	JGS 5	19—2093
JOSH 5	2—1055	27—2044 <sup>b</sup>
2—656 <sup>b</sup>	14—3116	JGS 19
3—657 <sup>b</sup>	15—2710	16—1432 (4)
11—2247 <sup>b</sup>	17—687 (2)	19—3088 (2)
15—404 (3); 1125 <sup>b</sup>	19—2229 (2)	JGS 20
JOSH 6	23—2037 <sup>b</sup>	16—1169 (2)
1—2786 <sup>b</sup>	24—1558; 2556 <sup>b</sup>	26—1099 <sup>b</sup>
16—2525	30—735 (5); 884	RUTH 1
26—722 (1); 1389; 2713	JGS 6	1—2214 (3)
JOSH 7	4—1055	RUTH 2
5—3075	11—1227	14—2247 <sup>b</sup>
20—2559 (2)	34—2842	17—2214 (3)
21—687 (1); 2076; 2234	36—332	RUTH 3
26—2665 <sup>b</sup>	JGS 7	3—877 <sup>b</sup>
JOSH 8	1—2082	7—2214 (3)
30—890; 1858	2—1227 (5)	13—1272 <sup>b</sup>
	13—405; 2576	
	22—2168 (4)	

RUTH 4	1 S 12	1 S 23
4—2541	11—4	1—296 (1)
6—2556	1 S 14	3—690 (2)
7—2779	4—512 <sup>b</sup>	7—593; 3097 <sup>b</sup>
11—2524	8—332	9—2466 (1); 2819 <sup>b</sup>
1 S 1	14—38	9—2466 (1); 2819 <sup>b</sup>
3—2893 <sup>b</sup>	18—85; 2894	15—2761 <sup>b</sup>
20—478; 2677	41—331 (3); 518; 3041 (4)	1 S 29
24—2450 <sup>b</sup>	1 S 15	4—2536
1 S 2	3—2698 (5)	1 S 30
1—2093; 3100 <sup>b</sup>	11—3034 (1)	6—2489
18—8; 1455	22—1538 (2); 2175	1 S 31
19—2450 <sup>b</sup>	24—2559 (2)	10—2377 (2)
25—2019 (1)	27—670	11—530 (3)
27—2450 <sup>b</sup> ; 2451; 3131	29—2337 <sup>b</sup> ; 2558; 3034 (3)	2 S 1
1 S 3	30—2700 (3)	18—512
1—2462 (3)	33—763	19—2700 (4)
19—2461 (6)	1 S 16	23—885 <sup>b</sup>
1 S 4	1—2462 (5)	2 S 2
1—2891 (4)	5—838	14—1169 (2)
3—245 <sup>b</sup>	6—2020	2 S 3
8—1255 (a)	14—66 (2); 2680	35—1099
20—2050	20—3088	2 S 4
1 S 5	1 S 17	9—2535 <sup>b</sup>
2—2377	7—2234	2 S 5
6—2403	17—2247 <sup>b</sup>	2—2921 (9)
1 S 6	25—289 (2)	6—1614 (4); 1823 <sup>b</sup>
1—2231 (3)	31—2680	8—1609 (3)
8—377 (6)	49—1169 (2)	20—3075
9—593; 1336; 2189 (5)	1 S 18	2 S 6
21—12	5—2093	7—3113
1 S 7	20—2555 <sup>b</sup>	14—8; 1170
5—2019 <sup>b</sup>	21—2819 <sup>b</sup>	20—2048
6—4	1 S 19	23—2034
17—838	18—2462 (4)	2 S 7
1 S 8	1 S 20	1—2120
6—2462; 2698 (5)	6—1442	3—2460 (4)
7—256 <sup>b</sup>	27—541	5—2020 (5)
10—2918 (3)	1 S 21	7—2940
11—1800 (3)	1—2894	11—2040 (1)
15—289 (2); 2093	5—1003 (7)	12—1458 (4); 1537 (5); 2464 (2)
1 S 9	13—1961 (1)	14—2042 <sup>b</sup> ; 2827
4—2215 (2)	14—418 (4)	2 S 8
6—2462 (3)	1 S 23	11—2941 <sup>b</sup>
9—2019 (3); 2713; 2921 (7)	10—1129 <sup>b</sup>	17—3131 (5)
11—1391	19—1334	2 S 9
1 S 10	28—2699 (11)	7—2898 <sup>b</sup>
6—2579	1 S 24	11—2556 <sup>b</sup>
10—2841 (1)	3—1125 <sup>b</sup>	2 S 10
11—2700	13—2470 (2)	4—418; 2751 <sup>b</sup>
12—2470 (2)	1 S 25	2 S 11
25—1884 (12); 2551 (1)	13—2757 (4)	2—3039 <sup>b</sup>
27—2918 <sup>b</sup> ; 2919	18—510 <sup>b</sup> ; 2247 <sup>b</sup>	15—2521
1 S 11	41—1125 <sup>b</sup> ; 3072 <sup>b</sup>	2 S 12
6—2699 <sup>b</sup>	1 S 26	1—2243 <sup>b</sup>
14—2557 <sup>b</sup>	20—1118 <sup>b</sup> ; 2254	8—504 <sup>b</sup> ; 1129 <sup>b</sup>

2 S 12—*continued*  
 13—2799 (6)  
 15—2783<sup>b</sup>  
 16—1099<sup>b</sup>  
 27—2521<sup>a</sup>  
 28—2112  
 30—2074 (2)  
 31—118; 763

2 S 13  
 18—878 (3)  
 21—2555 (3)  
 28—3088

2 S 14  
 3—2093  
 11—2555 (3)  
 26—1320<sup>a</sup>

2 S 15  
 7—57 (1)  
 30—403<sup>b</sup>

2 S 16  
 6—1111  
 23—2198<sup>b</sup>

2 S 17  
 8—417<sup>b</sup>  
 17—954  
 25—2109  
 27—118  
 28—2247<sup>b</sup>

2 S 18  
 21—768

2 S 19  
 24—2034

2 S 21  
 1—1226  
 8—1376; 2556  
 19—1276

2 S 22  
 16—594

2 S 23  
 4—671 (9); 2464 (2)

2 S 24  
 1—3158 (4)  
 2—2919  
 17—1021 (*a*)  
 24—2641 (6)  
 25—109 (5)

1 K 1  
 9—954; 3155  
 50—109 (4)

1 K 2  
 19—2514  
 27—2450<sup>b</sup>

1 K 3  
 4—2823 (1); 2894<sup>b</sup>

1 K 4  
 4—3130 (6)  
 21—2918<sup>b</sup>  
 23—1124  
 25—3051  
 29—2470<sup>b</sup>; 3089 (2)

1 K 5  
 6—687 (2)

1 K 6  
 1—1775<sup>b</sup>  
 15—2930 (3)

1 K 7  
 9—527

1 K 8  
 4—2893 (1); 2894 (3)  
 21—244<sup>b</sup>  
 27—310 (8); 2190<sup>b2</sup>  
 63—2449

1 K 9  
 7—2470 (3)  
 11—3003 (2)<sup>a</sup>  
 16—551 (5)

1 K 10  
 1—1170 (7)  
 15—687 (2)  
 18—3000<sup>b</sup>  
 22—2197<sup>b</sup>  
 25—2918<sup>b</sup>  
 27—2793

1 K 11  
 5—1255 (*i*)  
 15—912 (13)  
 23—436  
 41—1885

1 K 12  
 10—1111  
 14—2551<sup>b</sup>  
 16—1593 (3)  
 21—2462 (5)  
 25—124  
 26—1255 (*ii*)  
 28—109 (9)  
 30—1594 (6)

1 K 13  
 2—744  
 4—3098<sup>b</sup>  
 11—2183<sup>b</sup>

1 K 14  
 3—516 (5)  
 7—2462 (5)  
 25—912 (15); 2359

1 K 15  
 2—10  
 3—3102

1 K 16  
 1—2462 (5)  
 25—2193 (4)

1 K 16—*continued*  
 31—1675  
 34—12; 1389; 2075; 2713

1 K 17  
 1—2461  
 21—976

1 K 18  
 19—2898<sup>b</sup>  
 21—1255 (*i*); 1583 (7)  
 26—1964 (6)  
 28—1857; 2462 (4)  
 40—763  
 44—670; 3085 (2)

1 K 19  
 11—1538 (7)  
 16—934 (1)  
 21—1183

1 K 20  
 31—1343  
 34—570 (1); 687 (3); 857 (16);  
 2192 (3)  
 37—2462 (4)

1 K 21  
 29—2461<sup>b</sup>

1 K 22  
 20—66 (2)  
 29—80  
 34—2106  
 48—687 (2)

2 K 1  
 2—346 (5); 348  
 8—736; 877 (4)  
 9—579

2 K 2  
 9—935 (3)  
 11—975 (1); 1460 (II)  
 12—596 (7)

2 K 3  
 11—412 (3)  
 13—1580  
 15—2460 (2) 2579

2 K 4  
 8—1182  
 19—2879<sup>b</sup>  
 23—2462 (5); 2910 (2)  
 34—976

2 K 5  
 7—1867 (1)  
 17—108<sup>b</sup>  
 18—1255 (*i*); 2594  
 20—1182<sup>b</sup>

2 K 6  
 12—2461  
 25—287 (4)

2 K 7  
 2—315 (4)

2 K 8	2 K 20— <i>continued</i>	1 Ch 13
11—267	12—367	3—85; 2894 <sup>b</sup>
16—932 (7)	18—2030	5—2768
2 K 9	20—1609 (4); 2225 (3)	8—1112
11—1961 (1)	2 K 21	10—3043
22—1964	3—2081 <sup>b</sup>	1 Ch 14
27—2229 (2)	6—345 <sup>b</sup> ; 1963 <sup>b</sup>	7—1255 ( <i>ii</i> )
2 K 10	7—1455 (4)	1 Ch 17
15—2535 (2)	2 K 22	1—2120
18—1585 (8)	8—464 ( <i>g</i> ); 556; 838 (9); 1853;	21—2541
20—2682 (1)	1883	1 Ch 19
22—601	13—839	4—2751 <sup>b</sup>
2 K 11	2 K 23	1 Ch 21
4—2379 <sup>b</sup>	2—464 ( <i>g</i> ); 1753 (3)	1—3158
12—2416 <sup>b</sup>	4—1258 (4); 2040 (1); 2081 <sup>b</sup>	16—308 <sup>b</sup>
2 K 13	5—298 (3); 299	1 Ch 23
5—570 (2); 1346 (2); 1577	7—1336	27—1885
14—332; 596; 1576 (2)	8—2234	1 Ch 24
19—2666 (3)	10—2638 <sup>b</sup>	14—2918 <sup>b</sup>
2 K 14	11—1454 <sup>b</sup>	1 Ch 26
9—1085; 2243 (1)	15—2184 (3)	24—143 (1)
10—1239	2 K 24	1 Ch 27
11—115; 2231 (3)	13—1687	24—1885
22—115 (6)	15—2514	28—2182
25—122 <sup>b</sup>	20—573 (10)	1 Ch 28
2 K 16	2 K 25	3—2940 <sup>b</sup>
3—345 <sup>b</sup> ; 2638	7—764	11—234 (1); 2264 <sup>b</sup>
6—2588	12—574 (14)	19—2895 <sup>b</sup>
8—841 (3)	16—3079	1 Ch 29
2 K 17	27—1577 <sup>b</sup>	18—1292
3—2747 <sup>b</sup>	1 Ch 2	20—3111
4—912 (17); 1428 ( <i>b</i> )	16—2109; 3148	22—3130 (6)
6—2693	18—1185 (6)	24—2453
9—2234	1 Ch 4	29—1884
16—298 (3); 2514 <sup>b</sup>	21—736	2 Ch 1
26—1428; 2869 (3)	23—2233	3—2894 (3)
27—1255 ( <i>a</i> )	1 Ch 5	7—2823 (5)
30—299 (5); 2869 (1)	5—2893 (1)	16—687 (2)
31—2638 <sup>b</sup>	26—570 (2)	2 Ch 2
37—679	1 Ch 7	6—2190 (3)
2 K 18	5—2295	2 Ch 3
4—839 (7); 1386 (2); 1455 (6);	21—1055	1—2930 (4); 3152 (5)
2132; 2234; 2738 <sup>b</sup>	29—504	2 Ch 5
9—2747 <sup>b</sup>	1 Ch 8	3—2894 (3)
17—2522 <sup>b</sup>	33—346	2 Ch 6
26—361 (8)	1 Ch 9	7—2941
2 K 19	11—2443	2 Ch 9
8—2523	22—2921 (7)	4—841 (3)
9—912 (17)	39—346	2 Ch 10
13—231 (17); 2722 (2)	1 Ch 11	10—1111
28—2155 <sup>b</sup>	6—1609 (3)	2 Ch 11
29—3051	17—3074	11—663 <sup>b</sup> ; 2182; 3088
2 K 20	1 Ch 12	
7—1109 (6)	8—1169 (2)	
8—1388	18—2460 (2)	
9—2981 <sup>b</sup>	32—1542 (4)	
11—841		



2 Ch 12	EZR 3	NEH 10— <i>continued</i>
2—912 (15)	13—966	32—2918 <sup>b</sup>
3—913 <sup>b</sup>	EZR 4	34—1104
2 Ch 13	7—260 <sup>b</sup> ; 361 (8)	38—1857 <sup>b</sup>
5—2556 <sup>b</sup>	10—2151	NEH 12
2 Ch 14	13—2919 (2)	22—2131 (5)
9—912 (16)	14—729 <sup>b</sup> ; 1123; 2556 <sup>b</sup>	NEH 13
2 Ch 16	EZR 5	3—2057 (2)
7—2921 (7)	17—1886 <sup>b</sup>	5—2182
8—912 (16)	EZR 6	15—535 <sup>b</sup>
9—1128 <sup>b</sup>	15—575 (19)	22—2682 (1)
12—262; 2666 (3)	EZR 7	26—1096 (9)
14—529 <sup>b</sup> ; 530; 744	10—903 (5)	28—556 (2)
2 Ch 18	27—2430 <sup>b</sup>	EST 1
3—2047	EZR 8	5—1008 (8)
2 Ch 19	23—2430 <sup>b</sup>	10—3088 (2)
10—2921 (6)	EZR 9	EST 2
2 Ch 20	1—575 (20)	20—2556 <sup>b</sup>
24—2168 (4)	11—1376 (2)	EST 3
36—687 (2)	EZR 10	10—2709 (3)
2 Ch 21	6—1099 <sup>b</sup>	EST 5
18—511	19—728	1—1009
19—884 <sup>b</sup>	NEH 1	EST 7
2 Ch 24	9—2558 <sup>b</sup>	8—1086
7—318 (4)	NEH 2	9—1337
20—2460 (2); 3129 <sup>b</sup>	4—2430	EST 9
2 Ch 28	6—2131 <sup>b</sup>	24—1957 (1)
3—2453 (4)	13—1598 <sup>b</sup>	JOB 1
2 Ch 29	NEH 3	1—1679 <sup>b</sup> ; 1681
24—2536	5—2129 <sup>b</sup>	4—384 <sup>b</sup>
25—2096; 2462 (5)	NEH 4	5—1680 (1); 2642 (7)
2 Ch 32	1—856 (10)	6—2694 (4); 2695 (2)
28—2182	4—2430 <sup>b</sup>	JOB 2
30—1609 (4); 2225 (3)	NEH 5	1—2826 <sup>b</sup>
31—1386 (4); 841 (2)	7—2666 (4)	3—1685 <sup>b</sup>
2 Ch 33	8—2541	4—2814
6—1963 <sup>b</sup>	17—2898 <sup>b</sup>	11—1682
11—1978 (1); 1979 (4)	18—495	JOB 3
2 Ch 34	NEH 6	5—485
8—1752	7—2433 (5)	8—310 (5)
14—1883 <sup>b</sup>	NEH 7	9—308 (7)
2 Ch 36	61—2712 <sup>b</sup>	23—1682 (4)
13—2854	64—2295	24—3075
21—75 (7)	NEH 8	JOB 4
EZR 1	1—327; 2104	3—1682 (1)
1—368	8—556; 1834 (11); 2911 (4)	7—934
EZR 2	NEH 9	9—2841 (1)
3—610 <sup>b</sup>	6—2478	14—495 <sup>b</sup>
36—1076 (8)	7—613 (4); 2477 (1)	21—2948
59—2712 <sup>b</sup>	29—2780 <sup>b</sup>	JOB 5
62—2295	30—2579	1—1682 <sup>b</sup>
65—2805	NEH 10	27—934
69—535	28—576	JOB 6
	31—2635 (4)	5—514 <sup>b</sup>
		6—1682 (2); 2204

<b>JOB 6—continued</b>	<b>JOB 19—continued</b>	<b>JOB 32</b>
16—2819 <sup>b</sup>	23—1683 <sup>b</sup> ; 1885 <sup>b</sup>	3—930 <sup>b</sup>
25—2560 <sup>b</sup>	24—2297 <sup>b</sup> ; 2900	19—1684 (1); 3087 (4)
30—2348	25—67 (III); 976 (3); 1260 <sup>b</sup> ; 1460 (3); 2499 (12); 2563	<b>JOB 33</b>
<b>JOB 7</b>	27—1685 (2)	4—2495 (2); 2497 (7); 2838 (3)
17—1682 <sup>b</sup> ; 2056	<b>JOB 20</b>	14—1684 (1)
19—2846	5—67	24—1460 (3); 2531 <sup>b</sup>
21—1782	29—3157	<b>JOB 34</b>
<b>JOB 9</b>	<b>JOB 21</b>	13—2479
6—315 (2)	5—1684 (2)	37—1686
7—301 ( <i>d</i> )	17—553	<b>JOB 36</b>
9—311 (10); 313 <sup>2</sup>	<b>JOB 22</b>	16—523
24—488 <sup>b</sup>	6—2409	27—315 (5)
25—966 (4)	12—307	<b>JOB 37</b>
32—1683 (4)	23—1683 <sup>b</sup>	5—696
33—799 <sup>b</sup> ; 2018 (1); 2019 (1)	<b>JOB 23</b>	9—313 (1); 3083
<b>JOB 10</b>	3—1260 <sup>b</sup>	16—315 (6)
8—2497	10—67 (2); 1684 (3)	17—3086 (3)
<b>JOB 11</b>	<b>JOB 24</b>	<b>JOB 38</b>
7—1816; 3033 <sup>b</sup>	2—1687	2—1685 (2)
8—307; 692 (4)	3.9—2409	7—308 <sup>2</sup>
9—2016	10—2752	9—2874
16—3075	<b>JOB 26</b>	12—302 <sup>b</sup>
<b>JOB 12</b>	6—2761 <sup>b</sup>	14—2708 (1)
6—2712	7—3152	22—314 <sup>b</sup>
9—2479	12—2144 (4)	31—311 (10); 312 <sup>3</sup>
12—269	13—309 (1)	32—299 <sup>2</sup> ; 313 <sup>2</sup>
17—1687	<b>JOB 27</b>	33—301 <sup>b</sup>
25—881 (IV)	3—2497 (4)	<b>JOB 39</b>
<b>JOB 13</b>	8—1684 (3)	8—2530
3—1683 (1)	<b>JOB 28</b>	26—3088 <sup>b</sup>
23—1782	1—2044	27—885 <sup>b</sup>
27—2455 <sup>b</sup>	7—1091 <sup>b</sup>	<b>JOB 40</b>
28—1868	12—408 (4)	2—1685 (2)
<b>JOB 14</b>	22—3	3—926
7—1683 (3)	23—1913 (4)	4—2093
13—2563	26—1130	10—2202
14—976 (3)	28—1686 (3)	16—1917 <sup>b</sup>
16—377 (4)	<b>JOB 29</b>	21—2544 (2)
17—2709	2—1888 (11)	24—2155 <sup>b</sup>
<b>JOB 15</b>	3—553	<b>JOB 41</b>
4—1683 <sup>b</sup>	7—2474 (3)	2—1115; 2155 <sup>b</sup>
12—3088 <sup>b</sup>	9.10—2093	5—476; 1168
19—1687	12—2494	18—2130
27—1086	17—1572	24—2052
33—1122 (4); 2185 (2)	<b>JOB 30</b>	<b>JOB 42</b>
<b>JOB 16</b>	4—1781	1—1685
4—1683 <sup>b</sup>	19—269	5—2559
10—2093	25—2837 <sup>b</sup>	6—2558
12—1169 (2)	<b>JOB 31</b>	7—934; 1685 <sup>b</sup> ; 2642 (7)
15—2093	1—25 (5)	8—2019 (2)
<b>JOB 18</b>	13—2494	10—1687; 1693 ( <i>a</i> )
6—553	20—1917 <sup>b</sup>	<b>Ps 2</b>
13—2814	26—314; 1891; 2081	1—2518
15—522 <sup>b</sup>	35—2780	7—2042 <sup>b</sup> ; 2464; 2826
<b>JOB 19</b>	40—930	8—282 <sup>b</sup>
9—1236 <sup>b</sup>		9—2426 <sup>b</sup>
20—2814		

Ps 4	Ps 24	Ps 42
5—2649 (2)	2—316 (7)	2—2837
6—1460 (3)	3—1404 (2); 2508	4—3110 (2)
Ps 6	4—2494	9—3035 (5)
5—2494 (8)	8—1267 (4)	Ps 44
Ps 7	10—1129 (3)	14—2470 (3)
3—2493	Ps 25	17—2493
12—2558 <sup>b</sup>	7—2019 (1)	23—1259 (3)
Ps 8	14—728 (1); 2104 (2)	Ps 45
1—1265	16—3020 <sup>b</sup>	1—2297 <sup>b</sup>
3—1111 <sup>b</sup>	22—2541	Ps 49
4—2829	Ps 26	3—2476 (3)
Ps 9	6—219	7—2531; 2555 (3)
17—975; 1251	Ps 28	8—2837 (2)
Ps 10	1—1266 (6)	14—976 (2); 2502
11—2192 (6)	4—3084	15—2563
Ps 11	Ps 30	Ps 50
1—476 <sup>b</sup>	3—2337 <sup>b</sup>	5—2649 (2)
6—522 <sup>b</sup> ; 2819 <sup>b</sup>	9—2494 (8)	11—476 <sup>b</sup>
Ps 13	Ps 31	13—1857 <sup>2</sup>
1—1086	1—1089 <sup>b</sup>	23—2430 (3)
Ps 14	Ps 32	Ps 51
1—319; 1251	1—1464 (3)	3—2559 <sup>2</sup> ; 2591 <sup>b</sup>
Ps 15	2—1462	5—2798 (3)
1—1404	5—2019 (1)	6—2192
2—3026 <sup>b</sup>	Ps 33	7—667 <sup>b</sup>
Ps 16	6—1474; 2021; 3014 (5)	10—2550
2—1460 (3)	15—2495 (4)	16—2649 (2)
7—1797 <sup>b</sup>	18—1782	17—2559 <sup>b</sup> ; 2842 (3); 2845
8—976 (2); 2518	Ps 34	Ps 53
9—1906	8—2917 <sup>b</sup>	1—1251
10—615; 1888 <sup>b</sup> ; 2337 <sup>b</sup>	11—1102 <sup>b</sup>	Ps 56
11—975 (2); 2563	24—1089 <sup>b</sup>	5—3114
Ps 17	Ps 35	8—510 <sup>b</sup> ; 2923 <sup>b</sup>
1—2493	11—2493	Ps 57
15—976 (2); 2499 (12); 2563	13—1099 <sup>b</sup>	8—2430 (3)
Ps 18	17—1918; 3020 <sup>b</sup>	Ps 58
2—1537; 3035(5)	20—2515 <sup>b</sup>	4—886 (2)
5—2819 <sup>b</sup>	21—2093	Ps 59
20—2493	Ps 36	5—431 <sup>b</sup>
28—553; 952 (2)	5—1089 <sup>b</sup>	Ps 65
31—1258 <sup>b</sup>	6—3034 (3)	4—613 <sup>b</sup>
34—416 <sup>b</sup>	9—1891 (c)	5—2189 (6)
Ps 19	Ps 37	Ps 66
1—2574 (2); 3124 (1)	23—2482 (3); 2483 <sup>b</sup>	10—2793
4—1894	35—977 <sup>b</sup>	Ps 68
12—2192 (6)	37—975	11—2433 (5)
13—2493 <sup>b</sup>	Ps 38	13—871 <sup>b</sup> ; 3088 <sup>b</sup>
Ps 22	7—1917 <sup>b</sup>	Ps 69
1—2433 (3)	13—882	11—2470 (3)
15—2093	Ps 39	22—2898 <sup>b</sup>
21—3020 <sup>b</sup>	2—882	Ps 71
27—322 (3); 1022 <sup>b</sup>	13—2494	3—3035 (5)
Ps 23	Ps 40	Ps 72
2—2763 <sup>b</sup> ; 3075	6—2019 (1); 886 (1) <sup>2</sup>	2—2494
5—1321 (7)		4—2020 (5)

Ps 72—*continued*

5—302<sup>b</sup>  
6—2526 (5)  
18—2189 (6)

## Ps 73

3—67 (1)  
11—2571 (10)  
18—977<sup>b</sup>; 2502  
21—1797  
24—976 (2); 2499 (12); 2563  
25—1537

## Ps 75

5—2129

## Ps 76

2—2663

## Ps 78

18—2943  
60—2769; 2891 (4)

## Ps 79

3—3075  
6—3113 (1)  
12—504<sup>b</sup>

## Ps 80

1—310 (8); 2440 (3)  
17—2829

## Ps 81

3—303<sup>b</sup>  
6—413 (1)  
12—298 (2)  
13—2167 (*e*)

## Ps 83

14—506

## Ps 84

3—2839

## Ps 85

4—2558<sup>b</sup>

## Ps 87

7—3098<sup>b</sup>

## Ps 89

19—3057<sup>b</sup>

## Ps 90

1—1467 (3)  
2—1012 (10)

## Ps 91

3—2819<sup>b</sup>  
6—2348<sup>b2</sup>  
11—133 (1)

## Ps 94

3—2571 (10)  
7—2192 (6)

## Ps 96

13—977<sup>b</sup>

## Ps 97

7—1270 (1)  
10—1933 (2); 3113 (4)

## Ps 98

8—665<sup>b</sup>  
9—977<sup>b</sup>

## Ps 99

3—2492

## Ps 101

7—2855<sup>b</sup>

## Ps 102

4—3098<sup>b</sup>  
6—2206; 2297<sup>b</sup>  
7—2839  
8—1961 (1)  
26—3034 (4)

## Ps 103

1—2430 (3)  
5—885<sup>b</sup>  
8—2019 (1)  
12—1134 (6)

## Ps 104

15—1351 (2); 3088<sup>b</sup>  
19—303<sup>b</sup>  
23—1891  
29—2497 (4); 2562 (2)

## Ps 105

11—2264  
22—2719<sup>b</sup>  
33—1123

## Ps 106

40—3034

## Ps 107

9—2837<sup>b</sup>  
16—514  
20—2021  
37—3051

## Ps 110

1—265 (IX); 1478 (7); 2129;  
2518  
3—2202  
4—2028<sup>b</sup>

## Ps 113

1.9—1323

## Ps 115

1—1323  
17—2494 (8)

## Ps 116

1—1029 (*a*)  
15—2434<sup>b</sup>

## Ps 118

14—2189 (6)  
22—722 (2)

## Ps 119

30—3026  
45—1881<sup>b</sup>  
67—2484 (5)  
83—3088<sup>b</sup>  
96—517; 523

Ps 119—*continued*

100—131  
130—1891 (*a*)  
133—2493

## Ps 121

6—302 (5)

## Ps 122

3—691

## Ps 124

7—1143<sup>b</sup>; 2819<sup>b</sup>

## Ps 125

2—1598 (1)

## Ps 126

4—2838<sup>b</sup>

## Ps 127

5—2515<sup>b</sup>

## Ps 129

3—38; 2409<sup>b</sup>; 2704  
6—1293<sup>b</sup>

## Ps 131

2—3076<sup>b</sup>

## Ps 133

2—2441

## Ps 136

6—316 (7)  
15—1516; 2086<sup>b</sup>

## Ps 137

2—3085<sup>b</sup>  
3—2095<sup>b</sup>  
5—2492 (4)  
6—2093<sup>b</sup>  
8—763

## Ps 139

5—2190 (6)  
8—2761<sup>b</sup>  
9—304; 3088<sup>b</sup>  
13—1797<sup>b</sup>  
21—2494 (7)  
23—2192 (6); 2493<sup>b</sup>

## Ps 140

5—2819<sup>b</sup>

## Ps 141

9—2819<sup>b</sup>

## Ps 142

7—2456 (7)

## Ps 143

11—1089<sup>b</sup>

## Ps 145

3—3033<sup>b</sup>  
18—2574

## Ps 147

4—307  
5—3033<sup>b</sup>  
10—1865  
19—2574

<b>Ps 148</b>	<b>PROV 15</b>	<b>PROV 29</b>
8—3046	4—3009 <sup>b</sup> 19—2975	2—334 (1) 18—3057 <sup>b</sup>
<b>PROV 1</b>	<b>PROV 16</b>	<b>PROV 30</b>
6—2471 7—426 <sup>b</sup> 9—127 <sup>b</sup> 20—3091	4—2478 (4) 32—2842 33—593	4—1260 <sup>b</sup> 7—78 17—885 <sup>b</sup> ; 2533 <sup>b</sup>
<b>PROV 2</b>	<b>PROV 17</b>	<b>PROV 31</b>
7—2478 <sup>b</sup>	8—127 <sup>b</sup> 11—3006 <sup>b</sup> 12—417 <sup>b</sup>	1—3090 (3)
<b>PROV 3</b>	<b>PROV 18</b>	<b>ECCL 1</b>
3—3009 (2); 3114 <sup>b</sup> 6—2478 <sup>b</sup> ; 2482 (3) 21—2478 (4)	1—2474 7—2819 <sup>b</sup> 20—2093	2—895 (2) 7—315 (6) 9—2546 (1) 17—1961 (1)
<b>PROV 4</b>	<b>PROV 19</b>	<b>ECCL 2</b>
23—2496 (6)	15—2817 <sup>b</sup> 21—3034 (3)	1—895 (2) 6—1493
<b>PROV 5</b>	<b>PROV 20</b>	<b>ECCL 3</b>
15—3075	14—3090 <sup>b</sup> 27—2495 (2)	1—895 (2); 2478 <sup>b</sup> 11—421
<b>PROV 6</b>	<b>PROV 21</b>	<b>ECCL 5</b>
1—2872 13—1111; 1125 <sup>b</sup> 21—127 <sup>b</sup>	13—886 (2) 20—2182	1—1125 <sup>b</sup> 18—895 <sup>b</sup>
<b>PROV 7</b>	<b>PROV 22</b>	<b>ECCL 7</b>
3—3114 14—2666 <sup>b</sup> 20—303 <sup>b</sup> 23—2819 <sup>b</sup>	6—903 (4) 19—2476 (3) 23—1486 (8) 28—2212	6—508 <sup>b</sup> ; 2975 17—3090 <sup>b</sup>
<b>PROV 8</b>	<b>PROV 23</b>	<b>ECCL 8</b>
5—2798 14—2474 (3) 22—2021; 2472 <sup>b</sup> ; 3091 (7)	10—2212 23—3025 (1); 3026 <sup>b</sup> 29—881 31—1918	4—2833 (3) 12—812 <sup>b</sup>
<b>PROV 9</b>	<b>PROV 24</b>	<b>ECCL 9</b>
10—2472 <sup>b</sup> 17—3075	18—3090 <sup>b</sup> 20—553 31—2975	2—593 <sup>b</sup> ; 3090 (5) 7—3088 (2)
<b>PROV 10</b>	<b>PROV 25</b>	<b>ECCL 10</b>
2—2474 (2)	3—307; 2710 <sup>b</sup> 4—2545 6—3091 (5) 13—2210 (7) 21—2526 (5); 3086 (4) 28—2842	19—3088 (2)
<b>PROV 11</b>	<b>PROV 26</b>	<b>ECCL 11</b>
4—101 <sup>b</sup> 20—3034 25—1881 31—2474 (2)	1—2820 2—2839; 2874 <sup>b</sup> 7—1865 13—2471 18—1961 (1) 23—2545 <sup>b</sup>	4—670 (6) 9—978
<b>PROV 12</b>	<b>PROV 27</b>	<b>CANT 1</b>
2—2478 4—495 <sup>b</sup> 19—3026 <sup>b</sup> 21—2482 (3) 22—3034 (1)	22—514 <sup>b</sup>	7—2837 <sup>b</sup> 14—432 <sup>b</sup> ; 807 (2)
<b>PROV 13</b>	<b>PROV 28</b>	<b>CANT 2</b>
12—3009 14—2819 <sup>b</sup> 15—1337	9—886 (2)	1—1893 <sup>b</sup> ; 2750 <sup>b</sup> 4—384 <sup>b</sup> 7—2508 (4) 11—2526 (4)
<b>PROV 14</b>		<b>CANT 3</b>
10—1489 14—376 <sup>b</sup> 15—2798 30—495 <sup>b</sup> ; 813		2—2508 <sup>b</sup> 6—2427 <sup>b</sup>
		<b>CANT 4</b>
		1—1249 <sup>b</sup> 5—1179; 1893 <sup>b</sup> 11—2052 12—2709

CANT 5	ISA 6— <i>continued</i>	ISA 15
1—381 <sup>b</sup>	8—2019 (3); 3014 (5)	2—418 (5)
3—878	9—2517 (2)	7—3085 <sup>b</sup>
CANT 7	10—886 (2)	ISA 16
5—579; 1320 (5)	13—977	2—259
CANT 8	ISA 7	14—1395
6—2708 (1); 2709	4—2461; 2588	ISA 17
8—2555 (3)	6—81 (4)	6—2185 (2)
ISA 1	9—2465	10—3035
6—1676 <sup>b</sup>	10—2040; 2789 <sup>b</sup>	13—2975 (21)
10—2581 (2)	14—478; 1458 (2); 2464 (3);	ISA 18
11—1020; 1538 (2); 2559 <sup>b</sup> ; 2648 <sup>b</sup> ;	2518 <sup>2</sup> ; 2725 (3); 3051 <sup>b</sup> ; 3053 <sup>b</sup>	2—736 (13); 3122
2652 <sup>b</sup> ; 2683 (1)	18—1121; 1423	4—214 <sup>b</sup>
13—341	20—1321 (8); 2751 <sup>b</sup>	ISA 19
16—1042 (1)	ISA 8	1—1454 (4)
18—1292 (3); 2465; 2547	1—1885 <sup>b</sup> ; 2297 <sup>b</sup>	6—524
19—2175 <sup>b</sup>	5—2791 (2)	7—736
22—2793; 3087 <sup>b</sup>	8—2040	9—3077 <sup>b</sup>
23—488 <sup>b</sup>	13—2682 <sup>b</sup>	10—1117
25—2545 <sup>b</sup>	16—2463	14—881 (IV)
ISA 2	19—296 <sup>b</sup> ; 612; 690; 2102; 2466	18—302 (2); 912 (20); 1491;
1—2459 <sup>b</sup>	(1); 2562 (3)	2926 <sup>b</sup>
2—977 <sup>2</sup> ; 2046	ISA 9	25—609 (5)
3—1690 <sup>b</sup> ; 2581 (2)	6—31; 1458 (4); 2040; 2453 <sup>b</sup> ;	ISA 20
4—2409 <sup>b</sup>	2465 (8); 2780	1—2693
6—687 (3)	10—521 <sup>b</sup>	2—403 <sup>b</sup> ; 2112
10—1236	12—1294 <sup>b</sup>	ISA 21
18—1454 (4)	ISA 10	3—2207
22—2155 <sup>b</sup> ; 2189	3—1236	6—1311 (I)
ISA 3	5—292 <sup>b</sup> ; 1257 (5)	ISA 22
2—1964	10—1454 (4)	13—2666 <sup>b</sup>
6—1518 (4)	14—612	15—2891 (1)
10—2502	17—1891 (3); 2975 (21)	18—1168 <sup>b</sup>
11—812	20—2592	22—1793; 2780
15—2052	ISA 11	23—1236 <sup>b</sup>
16—127 (1)	1—1623 (4); 2020 (5); 2123	ISA 23
24—2455 <sup>b</sup>	2—2040	3—2768
ISA 5	4—2093	18—3003 (4)
1—78; 1085; 2243 (2)	5—877 (4); 1917 <sup>b</sup>	ISA 24
2—3087 (2)	9—2665	18—315 (4)
8—2592 (3)	10—384 (2); 1238	ISA 25
10—38	11—1458 <sup>b</sup>	6—976 (4); 3087 (4)
11—881	14—2465 (8)	7—3047
12—880 <sup>b</sup>	ISA 13	ISA 26
14—1236	8—2207	4—3034 (3); 3035 (5)
16—1258 (3); 2682 <sup>b</sup>	10—312 <sup>2</sup>	19—976 (4); 986 (1); 1888 <sup>b</sup> ;
20—3084	20—2948	2499 (4); 2563; 2665 <sup>b</sup>
22—3087 <sup>b</sup>	21—828	ISA 27
23—488 <sup>b</sup>	ISA 14	1—309 (2); 311 (9)
25—3113 (1)	4—2470 (3)	ISA 28
26—384 (2)	5—2702	1—881
ISA 6	9—2761 <sup>b</sup>	2—3075
1—61 (4); 2648 <sup>b</sup>	12—299 (5)	4—1109 (4)
3—1129	13—701	9—3076
4—1466 <sup>b</sup>	14—671 (9)	14—1387 <sup>b</sup>
5—1404	15—975	
6—2684 <sup>b</sup>	23—484 <sup>b</sup>	
	30—2557 <sup>b</sup>	

ISA 28— <i>continued</i>	ISA 38	ISA 47
16—2519 <sup>b</sup>	8—841; 2981 <sup>b</sup>	2—1865
23—2409; 2476 (3)	12—2948; 2977	8—1929 <sup>b</sup>
24—1341; 2243 (2)	14—2872	9.11—1964 (4)
29—2474 (3)	17—1134 (6)	13—303 (3); 332 (6)
ISA 29	21—1109 (6); 1122 <sup>b</sup>	ISA 48
4—612; 690	22—494	4—514; 2129 <sup>b</sup> ; 2804 <sup>b</sup>
8—1440	ISA 39	10—2545
10—2817 <sup>b</sup>	1—367	21—1932 (2)
11—2709 <sup>b</sup>	ISA 40	ISA 49
15—2192 (6)	1—678	1—322 (3); 1258
16—2426 <sup>b</sup>	5—1238	2—2020 (6)
23—2682 <sup>b</sup>	11—504 <sup>b</sup> ; 1258 (6); 2764	4—617
ISA 30	13—2056	6—2235
1—2666 (3)	22—315 (3)	10—2247
8—1885 <sup>b</sup>	27—1781 <sup>b</sup>	ISA 50
10—2921 (7)	28—1011 (2); 2189 (4); 3033 <sup>b</sup>	3—485
14—2425 <sup>b</sup> ; 2426 <sup>b</sup>	ISA 41	4—2020 (6); 2578 (4); 2740 <sup>b</sup>
15—1386 (3); 2465	4—3034	6—418 (6)
24—2469 <sup>b</sup>	7—737	11—978 (3)
27—3017 <sup>b</sup>	8—2020 (6); 2740 (6)	ISA 51
28—1572	10—1089 <sup>b</sup>	16—1353 (6)
33—522 <sup>b</sup>	22—1129	17—881 (IV)
ISA 31	25—2424 <sup>b</sup>	20—144
1—1257 (5)	ISA 42	ISA 52
3—2189 (3)	1—613 (5); 1258 (4); 2518;	11—323; 2507 <sup>b</sup>
7—1454 (4)	2579	12—2479 <sup>b</sup>
ISA 32	4—977 (2)	13—67 (4); 2041
1—1387	6—1089 <sup>b</sup> ; 2020 (6); 2592	15—2547
2—3075	8—1238 (7); 1258 (4)	ISA 53
11—2924	9—1129	3—37 <sup>b</sup>
ISA 33	22—2819 <sup>b</sup>	4—67 (4)
13—2479	25—3113 (1)	5—617; 1021; 1464
14—2864 <sup>b</sup>	ISA 43	6—72
17—1387 <sup>b</sup>	2—2479 <sup>b</sup> ; 3075	7—882; 1662 (c); 2023; 2025
21—523; 524 (3)	9—1129	8—1577 <sup>b</sup>
ISA 34	10—2020 (6)	10—2639; 2651 (11)
4—308 (8)	ISA 44	11—1306
7—3084 <sup>b</sup>	1—2020 (6)	12—1663
11—484 <sup>b</sup> ; 2145 (5); 2297 <sup>b</sup>	6—3034	ISA 54
13—828	8—1258 (4); 1266 (6)	14—2479 <sup>b</sup>
14—369; 2144	24—1507 <sup>b</sup>	ISA 55
15—2736 <sup>b</sup> ; 2737 (3)	25—300 (3)	1—510 <sup>b</sup> ; 2052; 3088 (2)
ISA 35	ISA 45	11—2021
7—2066; 2247 <sup>b</sup>	5—2484 (2)	12—665 <sup>b</sup>
8—2479 <sup>b</sup>	7—66 (I); 1042 <sup>b</sup> ; 2485; 2695	ISA 56
ISA 36	(2); 3158 (8)	1—2632 <sup>b</sup>
3—289 (1)	9—2426 <sup>b</sup>	3—2468
16—527 (4)	13—1089 <sup>b</sup>	10—882
ISA 37	15—739	11—2763 <sup>b</sup>
16—310 (8)	21—1782; 2065	ISA 57
22—2461	22—613 (5)	2—975
27—1293 <sup>b</sup>	23—1258 (4)	4—2093
29—2155 <sup>b</sup>	ISA 46	8—2156
30—3051	1—299 (5); 418	15—1012 <sup>b</sup> ; 2547 <sup>b</sup>
38—2750	4—2479 <sup>b</sup>	19—546 <sup>b</sup>
	11—477; 3034 (3)	

ISA 58	JER 3	JER 13
3—24	3—1128	11—877 (4)
8—1238 (7)	8—376 <sup>b</sup>	13—881 (IV)
9—1111	14—2558 <sup>b</sup>	18—2514
ISA 59	16—327 <sup>b</sup>	21—2207
3—2348	JER 4	23—2547
4—3026	1—2465	25—2016
19—3017 <sup>b</sup>	3—1307 (5)	JER 14
20—2519 <sup>b</sup>	11—1597 <sup>b</sup>	4—2409 <sup>b</sup>
ISA 60	21—384 (2)	7—376 <sup>b</sup>
1—1892 (4)	22—3089 (2)	14—2579
5—2542 <sup>b</sup>	25—477	19—2019 (3)
7—1236	JER 5	JER 15
8—2395 <sup>b</sup>	5—3127	1—2019 (4)
21—2547 (1)	16—2515 <sup>b</sup>	JER 16
ISA 61	17—1123	11—1589 (b)
1—618; 2020 <sup>2</sup> ; 2433 (5); 2456	24—505 (3)	16—1115
(7); 2518; 3014 (5)	26—1143 <sup>b</sup>	19—1258 (3)
3—1321 (7)	JER 6	JER 17
8—2648 <sup>b</sup>	1—2924 (1)	1—1885 <sup>b</sup> ; 2297 <sup>b2</sup> ; 2900 <sup>b</sup> ; 3114 <sup>b</sup> ;
ISA 62	10—657 <sup>b</sup>	3119 <sup>2</sup>
4—2508 (4)	14—1349	6—2247 <sup>b</sup>
11—1932 (2)	20—2559 <sup>b</sup>	10—2710 <sup>b</sup>
ISA 63	28—514	11—2254
1—1089 <sup>b</sup> ; 2592; 3087 (2)	29—2545 <sup>b</sup>	18—2632 <sup>b</sup>
9—1932 (2); 3014 (5)	JER 7	23—2854
10—2842 <sup>b</sup>	12—2769; 2891 (4); 2894	26—2649
ISA 64	16—1589	JER 18
6—2524 <sup>b</sup>	18—2514 <sup>b</sup>	2—89; 2424 <sup>b</sup> ; 2426 <sup>b</sup> ; 2461 <sup>b</sup>
8—2426 <sup>b</sup>	21—2643 (1); 2648 (b); 2897 (5)	5—2484 (2)
ISA 65	22—1538; 2666 <sup>b</sup>	14—1863
1—609 (5)	28—3026 <sup>b</sup>	22—2819 <sup>b</sup>
4—861 (ii)	31—1113 <sup>b2</sup> ; 1256 (e); 2666 <sup>b</sup>	JER 19
5—2155 <sup>b</sup> ; 2666 <sup>b</sup>	JER 8	2—89
11—299 (4); 593; 1152	6—2558	5—1113 <sup>b</sup> ; 2075 (4)
16—115 <sup>b</sup>	7—2863 <sup>b</sup> ; 2874 <sup>b</sup>	11—2426 <sup>b</sup>
17—977 (2); 1354 (9)	8—1082 (2); 1590; 3089 (2)	JER 20
21—3051	11—1349	2—2456 (5)
ISA 66	JER 9	7—2460
1—2190 (3)	3—3026 <sup>b</sup>	9—2433 (3)
7—2207	17—530	JER 22
18—322 (3)	25—657 (3)	13—1022
22—977 (2)	26—418; 657 (4)	23—2207
24—723; 978	JER 10	30—1577 (3)
JER 1	1—1590 (b)	JER 23
5—2495 (b)	2—300 (b); 303 (b)	2—2921 (9)
9—2093	13—315 (6)	5—2020 (5); 2040 <sup>b</sup>
11—308 <sup>b</sup>	17—2788 <sup>b</sup>	6—2465
18—2897 <sup>b</sup>	20—2948	9—881 (IV); 2047 <sup>b</sup>
JER 2	24—2113 (1)	13—2672 <sup>b</sup>
2—997 <sup>b</sup>	JER 11	16—2459; 2579
13—659 (3)	6—2433 (5)	23—2192 (6)
18—2768	13—1256	24—2190 <sup>b</sup>
22—2820 <sup>b</sup>	15—2897 <sup>b</sup>	25—2460 (3)
28—1256 (iii)	20—1589	29—706
32—2201 <sup>b</sup>	JER 12	33—528
33—3011	2—1797 <sup>b</sup>	
	9—1444	



JER 24	JER 36	LAM 3— <i>continued</i>
1—573; 1577 (3) 2—1109 (4) 7—2547 <sup>b</sup> 9—2470 (3)	1—2463 (6) 2—2248 23—2900 <sup>b</sup> ; 3122 <sup>a</sup> 30—3147 <sup>b</sup>	27—3127 29—2093
JER 25	JER 37	LAM 4
5—2559 (3) 10—553; 2052 <sup>b</sup> 12—1590 (6) 15—1074 25—922 (17)	5—573 (11) 15—2456 (5)	EZK 1
JER 26	JER 38	2—1071 <sup>b</sup> 3—2460 (2); 2578 (4); 2579
6—2769 10—2933 18—2409 <sup>b</sup>	21—2578 (4)	EZK 2
JER 28	JER 39	10—376 (3); 3122 <sup>b</sup>
16—2461	3—1962 (1); 2522	EZK 3
JER 29	JER 41	14—2460 (2); 2579
1—1577 (3) 5—1071 (b)	5—1510 (b)	24—1072
JER 30	JER 43	26—2578 <sup>b</sup>
2—2463 (6) 9—2040 <sup>b</sup> 13—2026	7—912 (18)	EZK 4
JER 31	8—2359 (3)	1—2900 <sup>b</sup> ; 3120
5—3051 9—609 (5) 15—2517 25—2837 <sup>b</sup> 29—977 (b); 1824 <sup>b</sup> ; 2470 (2); 2665 (2) 31—468 (2); 925 (III); 2022; 2517; 2666 (4) 32—729 33—2547 34—2665 <sup>b</sup> 35—301 (b) 37—307 (b) 38—2666 (6)	9—2903	9—417 <sup>b</sup>
JER 32	JER 44	12—882 <sup>b</sup>
2—2456 (5) 14—1886 (14); 2228 <sup>b</sup> ; 2900 <sup>b</sup> 35—2453 (4) 38—2547 <sup>b</sup> 39—468 (2)	1—2050; 2239 <sup>b</sup> 6—3113 (1) 15—913 (22) 17—2081 (b); 2514 <sup>b</sup> 30—912 (19); 2903	14—16
JER 33	JER 46	EZK 5
11—2649 15—2020 (5) 16—2465 18—2041 22—306 (6) 25—301 (b)	11—2026 14—2050 <sup>b</sup> 20—1367 <sup>b</sup>	2—1074
JER 35	JER 47	EZK 7
6—881; 2535 (2) 16—2554 (1)	5—381	12—75 <sup>b</sup>
	JER 48	22—2711 <sup>b</sup>
	11—2818; 3087 (4) 28—2395 <sup>b</sup>	EZK 8
	JER 49	3.11—1455 (4) 12—592; 1452; 2192 14—2908 16—2514 <sup>b</sup> 17—2156
	24—2207 31—2947 <sup>b</sup> 32—1320 (2) 35—922 (17)	16—2514 <sup>b</sup>
	JER 51	17—2156
	20—575 (18) 59—573 (10)	EZK 9
	JER 52	3—2455
	4—2787 (2) 21—1111 31—1577 <sup>b</sup>	9—2192
	LAM 1	EZK 11
	8—2112	5—2460 (2)
	LAM 2	EZK 12
	11—1236 (3); 1906 12—3088 (2) 14—1824 <sup>b</sup> ; 2578 (4)	8.11—2461
	LAM 3	22—2470 (2)
	15—484; 3110 25—2180	EZK 13
		1—2047 <sup>b</sup>
		2—1080; 2459 (1)
		3—2578 (4); 2579
		10—3038 <sup>b</sup>
		18—1793
		EZK 14
		1—2878 (2)
		6—2558 <sup>b</sup>
		14—1679 <sup>b</sup> ; 1687 (3); 2563; 2665
		(2)
		EZK 16
		4—2874
		10—377; 2201 <sup>b</sup>
		12—1127 <sup>b</sup>
		31—1395
		44—2470
		61—1080

## EzK 17

1—2471<sup>b</sup>  
2—2243 (1)  
17—2787 (2)  
18—728  
22—1079  
23—1080

## EzK 18

2—977<sup>b</sup>; 1081; 2470 (2); 2665  
(2)  
7—2409

## EzK 19

1—573 (7)

## EzK 20

1—2878 (2)  
26—2453 (4); 2666<sup>b</sup>  
41—2682<sup>b</sup>  
49—1072

## EzK 21

10—2236<sup>b</sup>  
21—296<sup>b2</sup>; 331 (1); 2466 (1)  
26—1080  
27—2040<sup>b</sup>; 2768<sup>b</sup>

## EzK 22

18—514; 2044; 2545<sup>b</sup>  
26—2451  
28—3038<sup>b</sup>

## EzK 23

1—1292  
3—517<sup>b</sup>; 2923  
4—2181  
12—675  
25—886 (1); 2155<sup>b</sup>  
33—881 (IV)  
41—2015 (III)

## EzK 24

2—2461  
11—2627<sup>b</sup>  
15—1071<sup>b</sup>  
17—1125<sup>b</sup>  
25—1072

## EzK 25

16—2378 (III)

## EzK 26

5—1115

## EzK 27

7—884  
12—2044<sup>b</sup>  
13—535  
17—2237  
22—2520

## EzK 28

13—603 (3)  
25—2682<sup>b</sup>  
26—3051

## EzK 29

19—2903

## EzK 30

3—671 (8)  
17—913 (23)

## EzK 31

4—316 (7)  
17—2630 (1)

## EzK 33

1—2921 (8)  
11—1042; 2559<sup>b</sup>  
15—2409  
20—2665 (2)  
22—2093; 2579  
32—1072

## EzK 34

6—2763<sup>b</sup>  
23—2040<sup>b</sup>  
26—1080

## EzK 36

13—2164 (*ii*)  
23—1081; 2682<sup>b</sup>  
25—390 (3); 2547 (1); 2548<sup>b</sup>  
31—2666 (4)

## EzK 37

1—976 (4); 2579  
15—1074<sup>b</sup>  
24—2040

## EzK 38

11—1140  
16—2682<sup>b</sup>  
17—1080<sup>b</sup>  
22—522

## EzK 39

4—1080<sup>b</sup>  
21—1238  
27—2682<sup>b</sup>

## EzK 40

1—2579  
2—1078 (*d*)  
3—2545  
38—2649

## EzK 42

16—2545

## EzK 43

1—1078  
2—1237 (6)

## EzK 44

4—1075  
6—2451  
9—656<sup>b</sup>; 1077 (*d*)  
15—2875  
20—403 (5)  
21—881

## EzK 45

18—327  
19—2650 (4)  
21—2257<sup>b</sup>  
22—1080

## EzK 46

17—75<sup>b</sup>

## EzK 47

1—1078 (*d*)  
9—1115  
12—2026

## EzK 48

12—1076 (2)

## DNL 1

1—785 (5)  
3—2030  
4—2702<sup>b</sup>; 3096<sup>b</sup>  
8—881  
11—2030  
21—786

## DNL 2

1—2576  
3—875  
10—296  
35—514  
41—2426<sup>b</sup>  
44—977; 1026 (1); 1805

## DNL 3

21—878 (4)

## DNL 4

3—1012 (10)  
23—223  
27—1042  
30—2128 (5)  
35—2189 (5); 2479<sup>b</sup>; 2483 (4)

## DNL 5

1—368 (40)  
10—155<sup>b</sup>  
11—433<sup>b</sup>  
25—2032

## DNL 6

10—2430<sup>b</sup>  
28—786

## DNL 7

2—786 (2)  
3—2829<sup>b</sup>  
7—154<sup>b</sup>  
10—301 (1)  
13—162<sup>b</sup>; 977; 1630; 2041 (*b*);  
2346  
14—1026 (1); 1805 (3)  
25—306

## DNL 8

1—786  
5—91 (1); 92 (*b*)  
7—93 (7)

**DNL 8—continued**  
 8—456 (2)  
 9—154<sup>b</sup>  
 13—306; 982<sup>b</sup>  
 15—2581<sup>b</sup>  
 17—2829<sup>b</sup>  
 21—456 (3)  
 25—2453<sup>b</sup>

**DNL 9**  
 1—81  
 2—460 (1); 556; 1882 (1)  
 24—2709<sup>b</sup>  
 25—2039  
 27—982<sup>b</sup>

**DNL 10**  
 1—786  
 2—1099 (b)  
 10—2235  
 15—882  
 16—2207  
 20—456 (2)  
 21—2453<sup>b</sup>

**DNL 11**  
 28—456 (4)  
 31—376; 982<sup>b</sup>

**DNL 12**  
 1—723; 787; 976 (5); 978 (3);  
 2499 (12); 2502; 2563; 2665<sup>b</sup>  
 4—2709<sup>b</sup>  
 6—306 (7)  
 11—982<sup>b</sup>

**Hos 1**  
 5—512

**Hos 2**  
 1—2464  
 3—2112  
 6—1428  
 8—1256  
 12—1123  
 14—99<sup>b</sup>  
 15—37

**Hos 3**  
 1—2527<sup>a</sup>  
 4—1456  
 5—2040

**Hos 4**  
 1—1426; 1427<sup>b</sup>; 3026<sup>b</sup>  
 12—269 (4); 331 (1); 2842  
 14—1391 (3); 2666<sup>b</sup>

**Hos 5**  
 10—3075

**Hos 6**  
 1—122<sup>b</sup>; 2465  
 2—976 (4)  
 3—215; 505 (3)  
 4—545

**Hos 6—continued**  
 6—1020 (c); 1538 (2); 2559<sup>b</sup>;  
 2648<sup>b</sup>; 2652<sup>b</sup>; 2683 (1);  
 2845

**Hos 7**  
 1—2672<sup>b</sup>

**Hos 8**  
 5—1448  
 12—1430; 1538 (2)

**Hos 9**  
 1. 9—722  
 7—2579  
 10—1109 (4)

**Hos 10**  
 5—542; 1448  
 11—669<sup>b</sup>; 2102<sup>b</sup>; 2409<sup>b</sup>  
 12—102<sup>b</sup>; 1307 (5)  
 14—2748

**Hos 11**  
 1—2683 (1)  
 2—545  
 4—1572  
 12—1090

**Hos 12**  
 1—2183  
 2—1554 (4)  
 6—2558<sup>b</sup>  
 11—545  
 12—102<sup>b</sup>

**Hos 13**  
 2—542<sup>b</sup>; 545<sup>a</sup>  
 8—417<sup>b</sup>; 584 (2)  
 14—976 (4)

**Hos 14**  
 2—546<sup>b</sup>; 3112  
 3—1428  
 4—376<sup>b</sup>; 2547<sup>b</sup>; 3034 (1)

**JOEL 1**  
 2—1688 (2)  
 7—1123  
 8—3051<sup>b</sup>  
 13—1099<sup>b</sup>  
 14—2682 (1)

**JOEL 2**  
 2—671 (8)  
 13—2202; 2648<sup>b</sup>; 3034 (1)  
 17—1693 (d); 2020  
 20—1690 (3)  
 28—2517 (3); 2548<sup>b</sup>; 2579  
 30—309  
 32—324 (4)

**JOEL 3**  
 1—1693  
 6—1305  
 10—2409<sup>b</sup>  
 14—1694 (f)  
 18—2052; 2778 (2)

**AM 1**  
 1—2461  
 2—764  
 5—2702  
 11—123<sup>b</sup>

**AM 2**  
 7—1448  
 8—880<sup>b</sup>; 2409  
 12—881

**AM 3**  
 2—613 (5); 977; 2665 (2); 3113  
 (1)  
 6—66 (1); 2695 (2)  
 7—124 (5); 1130  
 8—2460; 2719 (2)  
 10—545  
 12—121 (4)  
 13—123<sup>b</sup>  
 15—79 (7)

**AM 4**  
 4—124<sup>b</sup>  
 6—505 (3)  
 11—123<sup>b</sup>

**AM 5**  
 6—123<sup>b</sup>  
 8—311 (10); 313 (2)  
 15—2666 (4)  
 16—530  
 18—977; 2465  
 21—124; 1391 (3); 1594 (3);  
 2652<sup>b</sup>; 2666<sup>b</sup>; 2684 (5)  
 24—3075  
 25—298 (1)<sup>a</sup>; 1020 (c); 2897 (5)  
 26—372 (10)

**AM 6**  
 1—123  
 6—880<sup>b</sup>  
 7—384<sup>b</sup>  
 12—2409<sup>b</sup>  
 13—122 (3)

**AM 7**  
 1—2093  
 2—2019 (3)  
 3—3034  
 12—124 (5)  
 13—542<sup>b</sup>; 1537 (6)  
 14—125; 2460 (4); 2877  
 15—125  
 16—123<sup>b</sup>

**AM 8**  
 5—124  
 10—418<sup>b</sup>

**AM 9**  
 2—2189 (5)  
 6—315 (6)  
 9—977  
 11—122<sup>b</sup>; 2040; 2464 (3)  
 12—2112  
 13—2409  
 14—3051

OB	NAH 3	ZECH 6
1—2878 (4)	1—292 <sup>b</sup>	1—3034 (3); 3137 <sup>b</sup>
10—2174 (3)	5—2112	9—1748
	8—295; 2110	11—2041
		13—1748; 2443
JON 1	HAB 1	ZECH 7
2—2433 (5)	1—2578 (4)	11—2780 <sup>b</sup>
17—3082 <sup>b</sup>	13—1782	12—556; 2579
JON 3	HAB 2	ZECH 8
3—540 (4)	1—2578 (4)	6—2189 (4)
8—2558 <sup>b</sup>	4—1313; 2465; 2519 <sup>b</sup>	8—1089 <sup>b</sup>
10—2558	14—1238; 2665 <sup>b</sup>	23—1258 (3)
	18—1577	ZECH 9
MIC 1	HAB 3	9—2040 <sup>b</sup> ; 2348; 2464 (3)
1—2578 (4)		10—233 (3); 416 <sup>b</sup>
16—885	5—494 <sup>b</sup>	13—1305; 2465 (8); 3138 <sup>b</sup>
MIC 3	11—449 (10)	17—2763; 3088
3—614	16—495 <sup>b</sup>	ZECH 10
5—2093; 2466 <sup>b</sup>	17—1108 <sup>b</sup>	4—233 (3)
8—2579	ZEPH 1	11—2702
11—488 <sup>b</sup>	2—1753 (3)	ZECH 11
12—2046	8—3144	12—1766 (4)
	12—1752 <sup>b</sup>	ZECH 12
MIC 4	15—671 (8)	1—2495 (4)
1—2046 <sup>b</sup>	ZEPH 2	3—1169 (2)
2—2581 (2)	5—2378 (III)	4—1961 (1)
3—2409 <sup>b</sup>	11—3146 (2)	ZECH 13
4—1109; 3051	14—485	6—2462 (4)
5—1255 (a)	ZEPH 3	7—2519
8—2197	13—977	9—2545
13—514	14—3146	ZECH 14
MIC 5	HAG 1	5—121 (6)
1—2464 (3)	1—1078 (c)	16—609 (5); 977 <sup>b</sup>
2—2040	HAG 2	20—2666 (6)
3—1458 (4)	5—3014 (5)	MAL 1
11—2046 <sup>b</sup>	6—629; 833; 1318 (4)	7—2416
	7—832 <sup>b</sup>	9—2020
MIC 6	10—1318	MAL 3
5—2778 (1)	23—2040	1—833; 1631
6—2019 (1); 2638; 2652 <sup>b</sup> ; 2684 (5)	ZECH 1	2—2547 <sup>b</sup> ; 2820 <sup>b</sup>
7—2046 <sup>b</sup>	1—3137 (3)	5—1022; 1395; 1964
8—1257; 2648 <sup>b</sup> ; 2666 (4); 2799 (7)	6—2461 <sup>b</sup>	6—3034
9—1089 <sup>b</sup> ; 2476 (3)	ZECH 3	10—315 (4)
15—2181 <sup>b</sup>	1—1748 (1); 2695 (2)	16—1694 <sup>b</sup>
16—2193 (4)	8—1078 (c); 2040; 2041	MAL 4
	9—327	2—304
MIC 7	10—1109 (2); 3051	6—2562
1—1109 (4)	ZECH 4	Mt 1
4—2975	6—2842 <sup>b</sup>	16—3052
6—2556	14—2443	18—3016; 3055 (1)
11—2046	ZECH 5	19—1632 (3); 1998
16—2093	1—3137 (3)	20—1410 <sup>b</sup>
18—1292 (3)	9—3088 <sup>b</sup>	21—618 <sup>b</sup> ; 1134 (10); 1265
NAH 1		22—2479 (2); 2518 <sup>b</sup>
8—2151		
15—2111		
NAH 2		
5—2787 <sup>b</sup>		
6—2151		
11—292 <sup>b</sup>		

Mt 1— <i>continued</i>	Mt 5— <i>continued</i>	Mt 8— <i>continued</i>
23—2518 24—1741 25—519; 2003	24—2536 <sup>b</sup> ; 2652 (1); 2656 27—2946 <sup>b</sup> 28—1340; 2509 29—2030; 2735 (3)	22—812 <sup>b</sup> 23—448 (6) 27—2064 (6) 32—1166
Mt 2	32—865 <sup>b</sup> ; 1329; 1999 <sup>b</sup> 34—2172 <sup>b</sup> ; 2173 (4) 36—1321 (7) 37—2009 <sup>b</sup> ; 3126 (2) 38—1643 <sup>b</sup> ; 2504 <sup>b</sup> 39—600 40—877 (3) 41—2970 43—1029 <sup>b</sup> ; 1278; 1845 ( <i>f</i> ); 2133; 2683 <sup>2</sup> 45—2668 46—2920 <sup>b</sup> 48—1261 (1) <sup>2</sup> ; 1262; 1782; 2321 (3)	Mt 9
1—2848 2—1633 (3) 5—2479; 2518 6—2453 7—1134 (10); 1633 <sup>b</sup> 11—618 <sup>b</sup> 16—1741 ( <i>c</i> ); 1962 (2) 17—1291 (5); 2517 19—1381 <sup>b</sup> 23—2123	Mt 6	2—423 (2); 1135 6—336 ( <i>c</i> ); 2236 8—1796 (2) 10—1641 11—2009 <sup>b</sup> 13—1096 (11); 2652 (1) 14—26; 1104 16—1148 (1) 17—509 <sup>b</sup> ; 2814 20—128; 1374 23—513 (6); 2668 (7) 29—1067 32—882 <sup>b</sup> 35—1646 (4)
Mt 3	1—101 <sup>b</sup> ; 1782; 2429; 2735; 3111 <sup>b</sup> 5—2668 (7) 7—1964 (6); 2559 <sup>b</sup> 9—1261; 1262 <sup>b</sup> ; 1490; 1920 <sup>b</sup> ; 2190 10—628; 1630 11—777 12—2668 13—138 16—26 17—2063 19—2627 22—2667 (5); 2805 24—1972 <sup>b</sup> 27—2850 32—609 (2) 33—26; 1278; 2482 (3) <sup>2</sup> ; 2541 <sup>b</sup> ; 2801 (11)	Mt 10
2—2558 <sup>b</sup> ; 2657 3—2479 <sup>b</sup> 4—736 (17); 876 (2); 877 (4); 1909 (5) 6—388 7—396 <sup>b</sup> ; 1635; 2571 (6) 8—2558 <sup>b</sup> 9—2665 (2); 2666 (1) 11—387; 394 (3); 399 <sup>b2</sup> ; 401 (4); 618 <sup>b</sup> ; 2548 <sup>b</sup> 12—990 <sup>b</sup> ; 2502 <sup>b</sup> 14—1635; 1710 <sup>b</sup> 15—1846 <sup>b</sup> ; 2176 16—396 <sup>b</sup> ; 1410 <sup>b</sup> ; 3016 17—609 (2); 2827 (5); 3055 <sup>b</sup> 35—2683	Mt 7	5—2667 (4) 6—2320 <sup>b</sup> 11—1004 (1) 12—1096 (10) 13—397 14—1125 <sup>b</sup> ; 1433 (5) 17—197 (4) 22—2112 <sup>b</sup> 23—983 <sup>b</sup> ; 1646 <sup>b</sup> ; 1792 (1) 25—423 28—986 <sup>b</sup> ; 992 (6); 2497 (3); 2501 <sup>b</sup> 29—1131; 2839 <sup>b</sup> 30—1320 (3); 2189 (5) 32—336 <sup>b</sup> ; 2021 <sup>b</sup> 35—520 <sup>b</sup> ; 1933 37—1785 (1) 38—761 <sup>b</sup> 39—1889 (1) 41—2058; 2113 42—1029 <sup>b</sup> ; 1433 (5)
Mt 4	1—2735 ( <i>c</i> ) 6—1928 ( <i>d</i> ); 2652 (1) 7—1815; 2431 11—609 (2); 1261 (1); 1264; 2338; 2347 12—1029 <sup>b</sup> ; 1845 <sup>b</sup> 14—2668 (7) 22—989 23—990; 1130; 2503 24—527 (5) 26—804 29—336 (2); 618; 2021 <sup>b</sup>	Mt 11
1—50 (3); 154 (3); 1635; 1806 (4); 2122 <sup>b</sup> 3—2827 (5); 2943 (5) 4—1476; 1635; 1757; 2346 5—2944 7.10—1635 (3) 13—1639 (2) 17—1263; 1639 (3); 2434 18—1117 23—1640 <sup>b</sup> ; 1805; 2063	Mt 8	1—1646 <sup>b</sup> 3—2042 <sup>b</sup> 4—2063; 2064 9—2434 (6) 11—1644; 1711 (2); 2667 (3) 12—3051 <sup>b</sup> 16—1168 <sup>b</sup> 19—881; 2009; 2668 (8); 2920 <sup>b</sup> ; 3088 <sup>b</sup> ; 3091 (5) 20—2504 21—2427 <sup>b</sup> 22—2502 23—1315 (6) 25—348 <sup>b</sup> ; 2105; 2431; 2479 <sup>b</sup> 27—609; 618; 1261; 1889 (7); 2021 <sup>b</sup> ; 2827 (7); 3016 (10) 28—336 <sup>b</sup> ; 458 (2); 2022; 2347 29—1439 ( <i>c</i> ); 2922 (II); 3127
Mt 5		
1—2734 3—426; 2559 <sup>b</sup> ; 2734 (2); 2842 6—1291 (5); 1440 8—2547 9—2293 <sup>b</sup> 11—419 <sup>b</sup> 13—2664 <sup>b</sup> ; 2700 <sup>b</sup> 17—72 (3); 336 (2); 1096 (11); 1260 <sup>b</sup> ; 1844 <sup>b</sup> ; 1880 <sup>b</sup> ; 2519 18—1857 <sup>b</sup> ; 3125 <sup>b</sup> 19—1475 <sup>b</sup> ; 1845 20—102 ( <i>a</i> ) 21—782; 2800 22—853; 2523; 3038 23—1133; 1928 ( <i>d</i> ); 2652 (1)		

<p style="text-align: center;"><b>Mt 12</b></p> <p>1—1845 (2) 6—3111 (4) 8—14 (2) 10—3098<sup>b</sup> 18—2742 (7) 22—882<sup>b</sup> 23—114 24—154<sup>b</sup>; 423; 1068 28—1067; 1134 (9); 1263; 3016<sup>b</sup> 31—486; 1412 32—2502<sup>b</sup> 33—1703; 2652 (1) 34—2347 38—1644; 2565 (1) 40—1115 (2) 41—1728; 2502 42—2067; 2515 43—828 46—518<sup>b</sup>; 1741 (c); 2002</p> <p style="text-align: center;"><b>Mt 13</b></p> <p>3—420<sup>b</sup> 11—1805<sup>b</sup>; 2021<sup>b</sup>; 2105; 2244 14—2517 (2) 18—2244<sup>b</sup> 19—2694 22—612<sup>b</sup> 24—2053; 2479<sup>b</sup> 30—1976 (3) 31—2101<sup>b</sup> 33—1862<sup>b</sup>; 2243 (1) 35—1479<sup>b</sup> 37—154<sup>b</sup> 39—980 40—616 (1); 3038 41—989<sup>b</sup> 47—1115<sup>b</sup> 54—2021 55—519; 1632</p> <p style="text-align: center;"><b>Mt 14</b></p> <p>2—2042<sup>b</sup> 5—1646 (1) 6—1169 (5) 13—452<sup>b</sup> 15—515 20—1144; 2015 23—2431<sup>b</sup> 24—2207 36—128 51—1660 (3)</p> <p style="text-align: center;"><b>Mt 15</b></p> <p>1—1846 (a) 2—412<sup>b</sup>; 1628 (3); 2363; 3004<sup>b</sup> 11—1847 (4) 14—2726 (8) 16—2429 19—1023 20—3038<sup>b</sup> 23—2102<sup>b</sup> 24—2320<sup>b</sup></p>	<p style="text-align: center;"><b>Mt 15—continued</b></p> <p>26—2667 (4) 36—2431<sup>b</sup> 37—1144 40—2006</p> <p style="text-align: center;"><b>Mt 16</b></p> <p>2—3077 4—1728 5—2363 (4) 6—1862<sup>b</sup> 13—323; 1628<sup>b</sup>; 2830 (2) 14—2042<sup>b</sup> 16—609 (2); 741 (2); 1262<sup>b</sup>; 2042<sup>b</sup>; 2827 (5) 17—624 (2); 1067<sup>b</sup>; 1119 (5) 18—482; 651; 652<sup>2</sup>; 1315 (7); 1648 (5); 2350; 2667 (4) 19—474<sup>b</sup>; 1050; 1133 (5); 1793<sup>b</sup>; 1794; 1795 (4); 1796 (4) 21—2565 (1) 22—1649; 2043 24—619; 761<sup>b</sup>; 881<sup>b</sup>; 1785 (1) 25—1889 (1); 2541<sup>b</sup> 27—609 (2); 2571 (9) 28—1262 (5)</p> <p style="text-align: center;"><b>Mt 17</b></p> <p>2—1891<sup>b</sup> 4—2898 5—609 (2) 9—619; 2565 (1) 11—2562 19—1349 (2) 20—2102; 2189 (4) 21—26; 2432 23—2043 24—2176; 2918<sup>b</sup> 27—1649<sup>b</sup>; 1846<sup>b</sup>; 2080<sup>b</sup></p> <p style="text-align: center;"><b>Mt 18</b></p> <p>2—2668 (6) 3—399<sup>2</sup>; 1785<sup>b</sup> 4—1439 (c) 6—397; 2052<sup>b</sup>; 2129 8—990<sup>b</sup>; 1889 (1); 2668 10—610 11—619; 2320<sup>b</sup> 12—78 15—1050; 1133 17—651; 654<sup>b</sup>; 2667 (4); 2920<sup>b</sup> 18—474<sup>b</sup>; 653; 1796; 2350 19—75 20—336<sup>b</sup> 21—1133; 2244 (5) 26—61 34—1133 (3) 35—1133 (5); 2668</p> <p style="text-align: center;"><b>Mt 19</b></p> <p>1—1096 (10) 3—865; 1340; 1845 4—468 (3); 2416 (1)</p>	<p style="text-align: center;"><b>Mt 19—continued</b></p> <p>5—1037<sup>b</sup> 6—1095 8—764 9—865<sup>b2</sup>; 1999 (4) 13—2432 14—393<sup>b</sup> 16—1846<sup>b</sup> 28—990; 1354 (8); 2503; 2546 (1); 2562 29—1889 (1); 2112<sup>b</sup></p> <p style="text-align: center;"><b>Mt 20</b></p> <p>1—1654<sup>b</sup>; 1782 3—534 (2) 15—2805 18—619 19—2565 (1) 20—1486 (11) 22—394 (3) 25—335 (3); 1028 26—482 (1); 1294<sup>b</sup> 28—1135 (12); 1785 (1); 2022; 2043; 2531; 2653<sup>2</sup>; 2837<sup>b</sup> 29—406<sup>b</sup></p> <p style="text-align: center;"><b>Mt 21</b></p> <p>9—2042 12—383<sup>b</sup>; 1846<sup>b</sup> 18—1109 (4) 19—1655 (4) 22—2431 23—336<sup>b</sup> 25—394 29—2558<sup>b</sup> 31—1340 33—2346 34—2251 (4) 42—619 43—1262 (5) 45—1656</p> <p style="text-align: center;"><b>Mt 22</b></p> <p>4—385<sup>4</sup> 5—1998<sup>b</sup> 11—2548 12—882 14—2010 (2) 16—1380; 1383<sup>b</sup> 17—1847; 2920 (4) 23—2563<sup>2</sup>; 2659 25—2661 29—468<sup>b</sup>; 1476 (5) 30—494 31—972 (1) 32—975 35—1846 (c); 2133 37—835<sup>b</sup>; 1029 (3); 2056 (3) 39—1933<sup>b</sup> 40—2946<sup>b</sup> 42—2042<sup>b</sup> 44—2346 45—1656 (2)</p>
--	---	--

**Mt 23**  
 1—1845  
 2—336 (2)  
 3—2667 (4)  
 4—458 (2); 474<sup>b</sup>  
 7—2665  
 8—2350  
 12—1439 (c)  
 13—1028  
 15—206<sup>b</sup>; 1656; 2468  
 17—2682 (2)  
 22—2172<sup>b</sup>  
 23—136; 1088; 2364; 2591 (1);  
 2799 (7)  
 24—2129<sup>b</sup>; 2864  
 27—2222 (7)  
 33—2219 (1)  
 34—2058<sup>b</sup>  
 35—3129<sup>b</sup>  
 38—983  
 39—619

**Mt 24**  
 3—980  
 4—982<sup>b</sup>  
 5—619  
 6—2968<sup>b</sup>  
 8—981 (2)  
 18—877 (3)  
 24—942; 1887 (5); 2129<sup>b</sup>  
 27—986 (4)  
 28—886  
 29—833; 983; 1792 (1)  
 30—263 (1); 616 (1); 2829<sup>b</sup>  
 32—1109<sup>b</sup>  
 36—1792<sup>b</sup>; 2345<sup>b</sup>; 3016 (10)  
 41—516 (6); 736 (8); 2052  
 48—1042  
 49—880; 881 (3)

**Mt 25**  
 27—383<sup>b</sup>; 2080<sup>b</sup>  
 31—616 (1); 2021<sup>b</sup>; 2346; 2502<sup>b</sup>;  
 2829 (3)  
 41—743; 2502; 2503; 3038  
 46—1889; 2571 (8); 2668

**Mt 26**  
 2—619  
 5—2661 (2)  
 6—2795  
 8—2320  
 11—2421  
 12—2346<sup>b</sup>  
 17—1658 (1)  
 20—385 (2)  
 23—516; 2015; 2258 (10)  
 24—2043  
 26—2022  
 27—766<sup>b</sup>; 1928  
 28—323; 489 (3); 731<sup>a</sup>; 1135 (12);  
 1785 (1); 2652<sup>b</sup>; 2653 (2);  
 2654 (3)

**Mt 26—continued**  
 29—1925 (2); 1927 (a); 2637<sup>b</sup>  
 30—1323; 2430  
 36—2432 (2)  
 38—2497  
 39—2479<sup>b</sup>  
 47—726 (4)  
 53—1766<sup>b</sup>  
 54—1476<sup>b</sup>  
 57—1660 (4)  
 59—1670 (6)  
 61—1637<sup>b</sup>  
 62—1671 (8)  
 63—609 (2); 1845 (d); 2042<sup>b</sup>;  
 2173 (4); 2346  
 64—263 (1); 983<sup>b</sup>; 2251 (III);  
 2829<sup>b</sup>  
 65—2827<sup>b</sup>  
 66—1310  
 67—1169; 2660<sup>b</sup>; 2742 (7)  
 69—1661  
 70—2172<sup>b</sup>  
 71—2123  
 72—1887 (4)

**Mt 27**  
 2—2458  
 3—2558<sup>b</sup>; 2559 (2)  
 4—1661 (c); 2559 (2)  
 6—89  
 7—2425  
 9—1766 (4)  
 17—2885 (3)  
 19—1662 (2)  
 27—1173<sup>b</sup>  
 35—1169 (3)  
 38—2972  
 39—529  
 42—2365; 2943<sup>b</sup>  
 46—891<sup>b</sup>; 2347 (1); 2432 (3)  
 48—1446<sup>b</sup>  
 50—489; 2445  
 51—2892 (1)  
 52—1664  
 54—609 (1); 2827 (4)  
 62—2437  
 63—1664; 2565 (1)  
 66—531 (3); 2709 (3)

**Mt 28**  
 10—2188  
 14—2458  
 16—2368<sup>b</sup>  
 18—336<sup>b</sup>; 394<sup>b</sup>; 395; 396<sup>b</sup>; 616;  
 1666 (2); 2021<sup>b</sup>; 2829 (9)  
 19—388; 391 (4); 392<sup>b</sup>; 653;  
 742; 1100<sup>b</sup>; 1899; 2053;  
 2346<sup>b</sup>; 2637 (3); 2842; 2922  
 (II); 3011 (2); 3017<sup>b</sup>; 3020<sup>a</sup>;  
 3021 (22)  
 20—266

**Mk 1**  
 1—1281  
 4—1134 (7); 2558<sup>b</sup>  
 7—1125<sup>b</sup>  
 8—387; 394 (3); 619 (4); 2548<sup>b</sup>  
 10—390; 1410<sup>b</sup>; 3016  
 11—609 (2)  
 12—1635; 2943  
 15—1420 (2); 2558<sup>b</sup>; 2559<sup>a</sup>;  
 2657<sup>a</sup>; 2667 (2)  
 16—1117; 1639 (3)  
 21—3111<sup>b</sup>  
 22—336 (2)  
 24—828<sup>b</sup>; 2123  
 27—2021  
 34—2668 (8)  
 45—1640<sup>b</sup>

**Mk 2**  
 3—2236<sup>b</sup>  
 4—423 (2); 2222 (7)  
 5—1640<sup>b</sup>; 2668<sup>a</sup>  
 8—2346  
 10—336 (c); 2021<sup>b</sup>; 2022  
 17—2783<sup>b</sup>  
 18—2668<sup>b</sup>  
 19—1641  
 21—26; 1148 (1)  
 22—509<sup>b</sup>; 2814; 3087 (4)  
 23—3073 (3)  
 26—8; 85  
 27—1004; 1029 (a); 1642 (a)  
 28—2631 (3); 2829; 2946<sup>b</sup>

**Mk 3**  
 1—3098<sup>b</sup>  
 4—1642<sup>b</sup>; 1858  
 5—2571 (6); 3113 (4)  
 6—1284 (3); 1380; 1383<sup>b</sup>  
 13—1710  
 14—2058; 2199<sup>b</sup>  
 17—1707  
 21—1412; 2002  
 22—423; 2694 (3)  
 28—486; 1412  
 29—782; 2502<sup>b</sup>  
 30—1133  
 31—518<sup>b</sup>; 2002  
 34—1645

**Mk 4**  
 11—2105  
 12—2244; 2471 (3)  
 17—2324 (4)  
 26—1806 (6); 2479<sup>b</sup>  
 32—2101<sup>b</sup>

**Mk 5**  
 9—1645 (2); 2004  
 12—2564 (4)  
 15—2820<sup>b</sup>  
 21—1284  
 30—1646 (3)

<i>Мк 5—continued</i>	<i>Мк 10—continued</i>	<i>Мк 14—continued</i>
38—531 (6)	25—2129 <sup>b</sup>	22—2022; 2432 (2); 2668 <sup>b</sup>
41—2904	32—2022	23—1928
<b>Мк 6</b>	33—619	24—731 (2); 2025; 2652 (1);
5—1486 <sup>b</sup>	34—2565	2653 (2); 2655 (1)
6—1646 (4)	35—1654 <sup>b</sup>	27—2519
8—377; 517; 1433 (5)	38—394 (3)	36—59
9—2431 (1)	42—335 (3)	43—726 (4)
13—2783 <sup>b</sup>	45—1135 (12); 2022; 2530 (1);	51—2178 <sup>b</sup>
18—526	2653 <sup>a</sup> ; 2830 (3)	58—2565 (1)
21—478	46—406 <sup>b</sup>	61—2346
22—1169 <sup>b</sup>	<b>Мк 11</b>	62—2043; 2290 (1)
<b>Мк 7</b>	1—2021 <sup>b</sup>	66—983
1—2363; 3073 (3)	12—1109 (5)	67—2123
2—3038	14—1655 (4)	72—2349
3—412 <sup>b</sup> ; 2507 <sup>b</sup> ; 3004 <sup>b</sup>	15—137 <sup>b</sup>	<b>Мк 15</b>
4—390; 394 <sup>a</sup>	21—767 <sup>b</sup>	14—1661 <sup>b</sup>
6—2851 <sup>b</sup>	28—336 <sup>b</sup>	16—1173 <sup>b</sup>
7—389	30—394 (3)	17—1404 <sup>b</sup>
10—2582 (3)	<b>Мк 12</b>	22—2886 <sup>b</sup>
18—1847 (4)	6—336 <sup>b</sup>	23—3087 <sup>b</sup>
19—819	8—2022	26—2021 <sup>b</sup>
20—1647	12—1656 (a)	27—2972
22—2805	13—1380; 1383 <sup>b</sup>	29—78 (5)
26—2886 <sup>b</sup>	14—1847; 2920 (4)	34—2347; 2432 (3)
32—882 <sup>b</sup>	18—2563 (III)	36—1446 <sup>b</sup>
33—2846	20—2661 (2)	37—489
34—2432	24—1476 (5)	38—2892
<b>Мк 8</b>	25—986; 2565	39—609 (1)
15—1383 <sup>b</sup> ; 1648 (4)	28—2133	42—2437
22—488; 1070 <sup>b</sup> ; 1645 <sup>b</sup>	29—1933 (2)	44—762
23—1648 <sup>b</sup>	30—2056	<b>Мк 16</b>
27—2021	31—1846 (c)	9—184; 396; 751 (c)
29—619 (4); 2827 (5)	36—754 <sup>b</sup> ; 1475	11—2567 <sup>b</sup>
31—1284 <sup>b</sup> ; 2022; 2346; 2565 (1)	38—2665	15—391 (4); 394 <sup>b</sup> ; 2053; 2637
34—2657	40—2705	16—395
38—990; 2043	41—383 <sup>b</sup> ; 605 (5)	17—2996 <sup>b</sup>
<b>Мк 9</b>	44—1657	18—2415
1—1262 (5)	<b>Мк 13</b>	19—263 (2); 615
5—2898	2—2851 <sup>b</sup>	<b>Лк 1</b>
7—609 (2)	3—76 (1)	1—753 <sup>b</sup>
9—2565 (1); 3055 <sup>b</sup>	5—983	2—1936 (2)
12—2022; 2562	6—877 (3); 983 <sup>b</sup>	3—3053 (2)
17—882 <sup>b</sup>	7—2250 <sup>b</sup>	5—2445 (1)
29—829 <sup>b</sup>	8—981 (2); 1307 (5)	10—112; 1434
31—619 (4)	22—986; 1887 (5)	14—477 (1)
33—1649 <sup>b</sup>	26—2043	15—393 <sup>b</sup>
35—2667 (4)	28—1109 <sup>b</sup>	17—155 <sup>b</sup>
38—1707	30—982; 1262 (5); 2251 (4)	31—694 (4); 2335 (17)
41—1433 (5)	32—486; 989; 1792; 2345 <sup>b</sup> ;	32—1198 (2)
42—881 <sup>b</sup> ; 2052; 2129	2828 (8); 3016 (10)	35—1410 <sup>b</sup> ; 1630 <sup>b</sup> ; 2827 (4);
43—722 <sup>b</sup> ; 2502	39—2693 (2)	3016
50—966 <sup>b</sup> ; 2664 <sup>b</sup>	<b>Мк 14</b>	39—3054 (2)
<b>Мк 10</b>	3—2795	46—2497
2—1999 (5)	4—2320	48—3102 (1)
5—1477	7—2421	53—517 (2)
15—2291	8—2022; 2346 <sup>b</sup>	68—2042
17—1654 <sup>b</sup>	12—1658 (1)	77—1134 (10)
21—2668	16—2021 <sup>b</sup>	79—324
		80—1709



<p style="text-align: center;">Lk 2</p> <p>1—332<sup>a</sup>; 2600 (1)  2—45; 1632<sup>b</sup>; 1741  7—519; 1433; 2003  8—1470 (5); 2222 (7)  21—1846  24—1633 (2)  25—1005; 1631; 1806 (1); 2042  27—1114  35—1632 (3)  40—1634  46—726 (3); 1859  49—2346  51—2003<sup>b</sup>  52—1290<sup>b</sup>; 1291 (3)</p> <p style="text-align: center;">Lk 3</p> <p>1—2458  2—137  3—2558<sup>b</sup>  7—2571 (6)  11—877 (3)  12—2789<sup>b</sup>; 2920<sup>b</sup>  15—2042<sup>b</sup>  16—394 (3); 401 (4); 1125<sup>b</sup>;  2548<sup>b</sup>; 2684<sup>b</sup>  21—2479<sup>b</sup>; 3016  22—609 (2); 1410<sup>b</sup>  27—3147 (2)  38—141<sup>b</sup>; 146<sup>b</sup>; 609 (1); 2826 (2)</p> <p style="text-align: center;">Lk 4</p> <p>1—154<sup>b</sup>; 1411<sup>b</sup>; 1635 (1)  3—2943 (5)  4—1476; 1635 (3); 2346<sup>b</sup>  5—2944  6—2696 (3)  8—1635<sup>b</sup>  12—1635 (3)  16—323; 1639 (2)  18—2439  26—3132<sup>b</sup>  32—336 (2)  34—2123  35—1067<sup>b</sup>; 1640  38—2063  41—828</p> <p style="text-align: center;">Lk 5</p> <p>1—1639 (3)  2—1117  18—423 (2); 2236<sup>b</sup>  24—336  27—1641  36—26 (6)  37—509<sup>b</sup>; 2814  38—881  39—3087 (5)</p> <p style="text-align: center;">Lk 6</p> <p>6—3098<sup>b</sup>  11—1961 (2)  20—419<sup>b</sup>; 2427 (3); 2736</p>	<p style="text-align: center;">Lk 6—continued</p> <p>22—1050  26—2429  27—525 (2); 3091 (5)  29—600; 877<sup>b</sup>  37—1132<sup>b</sup></p> <p style="text-align: center;">Lk 7</p> <p>5—2229<sup>b</sup>; 2622  25—2525<sup>b</sup>  29—2920<sup>b</sup>  30—396<sup>b</sup>  32—1168<sup>b</sup>  34—2009; 2346<sup>b</sup>; 2920<sup>b</sup>; 3088  (2); 3091 (5)  36—1135; 1644 (d)  37—2004<sup>a</sup>; 2806  44—414<sup>b</sup>; 1125<sup>b</sup>; 3072<sup>b</sup>  46—1004  47—2668 (7)  50—2667; 3102<sup>b</sup></p> <p style="text-align: center;">Lk 8</p> <p>2—2006 (V)  10—2105; 2244  16—423 (3)  19—518<sup>b</sup>; 1741 (c)  28—828  35—2820<sup>b</sup></p> <p style="text-align: center;">Lk 9</p> <p>1—1067<sup>b</sup>  20—2827 (5)  21—1648 (5)  22—2565 (1)  24—1889 (1); 2320<sup>b</sup>  33—2898  34—2222  35—609 (2)  45—618  49.54—1707  55—2842  58—1645<sup>b</sup>  62—1645<sup>b</sup>; 2409<sup>b</sup></p> <p style="text-align: center;">Lk 10</p> <p>4—2665  7—1030; 1395  10—2133  15—1315 (6)  18—2667 (3); 2695  21—348<sup>b</sup>; 1412; 2668 (7); 3091  (5)  22—2592 (4)  27—2056 (4)  29—2667  38—2005<sup>a</sup>; 2006  42—2015</p> <p style="text-align: center;">Lk 11</p> <p>1—2479<sup>b</sup>  2—1920<sup>b</sup>; 2431 (1)  7—423 (3)  8—1462</p>	<p style="text-align: center;">Lk 11—continued</p> <p>13—1028; 2347  15—423  20—1111<sup>b</sup>; 2668; 3016<sup>b</sup>  21—2532; 2667 (3)  26—2004  29—1309<sup>b</sup>; 1728; 2347  31—2515  34—2805  38—389; 390 (2)  41—101<sup>b</sup>  43—2665  49—2058; 3092  51—3129<sup>b</sup></p> <p style="text-align: center;">Lk 12</p> <p>6—2839<sup>b</sup>  7—1320 (3); 2189 (5)  8—336<sup>b</sup>  10—486; 1412  16—1861  25—2850  31—26 (2)  32—1262; 1420 (2); 2668 (6)  35—2968 (2)  36—1815  42—1795 (5); 2854  45—881  47—33 (1); 1309<sup>b</sup>; 2504 (4)  50—394 (3); 2176 (3)  55—3086 (3)</p> <p style="text-align: center;">Lk 13</p> <p>1—2397; 2559<sup>b</sup>  2—813  6—1109 (5)  7—1108 (1)  15—1981<sup>b</sup>  16—2694 (3)  19—2101<sup>b</sup>  23—2503<sup>b</sup>  29—1262 (5)  32—1673 (7)</p> <p style="text-align: center;">Lk 14</p> <p>7—1652 (c)  8—3091 (5)  11—1028<sup>b</sup>; 1440  13—385 (2)  15—2015 (4)  16—2479  26—1343<sup>b</sup>; 1933 (2)  28—234 (1)  34—2700</p> <p style="text-align: center;">Lk 15</p> <p>4—2320<sup>b</sup>; 2542 (5)  11—2244 (5)  13—707 (2); 2264  16—507<sup>b</sup>  18—609 (2)  19—610  20—1291 (5); 2668 (7)</p>
--	--	---



## JN 2—continued

10—881  
 11—1705 (2)  
 15—1846  
 19—615; 1660; 1916; 2343<sup>b</sup>;  
 2565 (1); 2351<sup>b</sup>  
 23—2112<sup>b</sup>  
 24—1792 (1)

## JN 3

1—397<sup>b</sup>; 1637 (3); 2141<sup>b</sup>  
 3—395; 396<sup>b</sup>; 609 (2); 1030  
 (4)<sup>2</sup>; 1703<sup>b</sup>; 2547 (2); 2801  
 (11)  
 5—396 (4); 1413; 1701; 1711  
 (2)  
 6—399 (4)  
 7—398 (2); 2550  
 12—887<sup>b</sup>  
 13—2340<sup>b</sup>; 2344  
 14—2562  
 16—147<sup>b</sup>; 323<sup>b</sup>; 1030 (2); 1261<sup>b</sup>;  
 1262; 1638; 1698 (2); 1932<sup>b2</sup>;  
 2025; 2196; 2542 (5); 2559<sup>b</sup>;  
 2592<sup>b</sup>; 2828 (11); 3020<sup>b</sup>  
 17—1037<sup>b</sup>; 1705 (4)  
 19—1699; 1701 (1)  
 26—1710  
 29—1641  
 30—800  
 33—2709<sup>b</sup>  
 34—618; 1701  
 35—1261  
 36—812; 1135<sup>b</sup>; 1702 (1); 2502<sup>b</sup>;  
 2504 (3); 2571 (6)

## JN 4

3—1638  
 6—1699 (3)  
 9—158  
 14—510<sup>b</sup>; 2025  
 19—2058<sup>b</sup>  
 20—2851<sup>b</sup>  
 21—613 (3); 1404<sup>b</sup>; 2719 (1)  
 22—124<sup>b</sup>; 2574  
 23—1263 (6)  
 24—1697 (1); 1823 (3); 2946<sup>b</sup>  
 25—621<sup>b</sup>; 2039<sup>b</sup>; 2042<sup>b</sup>  
 34—2176 (2)  
 48—2789<sup>b</sup>

## JN 5

1—2507 (1)  
 2—423 (2); 1610 (9)  
 6—1713 (2)  
 14—1134 (10); 1641<sup>b</sup>  
 17—1261 (1); 1395<sup>b</sup>; 2481  
 18—968; 1261<sup>b</sup>; 1475<sup>b</sup>; 2345;  
 2829<sup>b</sup>; 3020<sup>b</sup>  
 19—336<sup>b</sup>; 1642; 2176  
 20—609 (2); 610 (5)  
 22—987 (3); 990; 2828 (11)  
 24—1889<sup>b</sup>; 2801 (11)

## JN 5—continued

26—1030 (3); 1697 (2); 1703 (3)  
 27—336<sup>b</sup>; 799  
 28—616; 976 (5); 1444<sup>b</sup>; 2251  
 (2); 2564  
 29—53 (2); 990  
 35—1892 (3)  
 36—609 (2)  
 39—1476<sup>b</sup>; 2710  
 40—1699; 2549 (IV); 3085<sup>b</sup>  
 41—1238 (2)  
 44—2429

## JN 6

4—1261<sup>b</sup>  
 6—2368<sup>b</sup>  
 14—2042<sup>b</sup>  
 26—1922 (2); 1927 (1)  
 27—2709<sup>b</sup>  
 33.53—323  
 35—517; 1030 (3); 1440  
 37—926 (V)  
 39—980; 2564  
 40—616  
 44—1704  
 45—1704 (2); 2517 (1)  
 47—619<sup>b</sup>  
 48—2025  
 51—1413; 1923 (4)  
 53—489 (3); 1889 (3); 1925 (4)  
 60—1726<sup>b</sup>  
 62—2344  
 63—1704<sup>b</sup>; 2495 (2)  
 64—1642<sup>b</sup>  
 66—1630; 2922  
 68—624 (2)  
 71—1765<sup>b</sup>

## JN 7

3—519<sup>b</sup>; 1666 (f); 1726<sup>b</sup>  
 17—227 (9); 2670<sup>b</sup>; 3025<sup>b</sup>; 3027  
 19—1846 (d)  
 23—1475<sup>b</sup>  
 27—2042<sup>b</sup>  
 35—1295  
 37—1413; 2025; 2142  
 38—1650<sup>b</sup>; 2670<sup>b</sup>  
 39—264<sup>b</sup>; 2549  
 46—336 (2)  
 49—1846<sup>b</sup>; 3091  
 53—2203 (4)

## JN 8

1—1650 (c); 2509  
 3—2004  
 11—1037<sup>b</sup>; 1134 (10); 1340  
 12—2025; 2670<sup>b</sup>  
 15—990  
 19—2345  
 23—2344<sup>b</sup>  
 24—812; 2570<sup>b</sup>  
 29—609 (2)

## JN 8—continued

32—2550 (6); 2694 (3); 3026<sup>2</sup>;  
 3027  
 33—2541 (2)  
 34—1881<sup>b</sup>  
 36—2686 (2)  
 42—1262; 2345  
 44—492 (5); 610  
 46—2344  
 53—609 (3)  
 58—2344 (VI); 3016 (11)

## JN 9

2—67 (5); 2484 (5)  
 3—813; 1705 (2)  
 6—2846  
 22—1050  
 25—624 (2)  
 39—1705 (4)  
 41—2670<sup>b</sup>

## JN 10

3—2764  
 4—2757  
 7—869  
 9—1651 (e)  
 10—323; 2541 (2); 2592 (4);  
 2801 (11); 2802; 2828 (11)  
 11—2497 (7)  
 12—78; 2763<sup>b</sup>  
 15—2837<sup>b</sup>  
 17—323; 609 (2); 615 (3); 1923  
 (4); 2176 (3); 2445; 3055<sup>b</sup>  
 18—336<sup>b</sup>; 2025  
 22—1726<sup>b</sup>  
 26—1704  
 28—2328<sup>b</sup>; 2502<sup>b</sup>  
 29—926 (V)  
 30—1261<sup>b</sup>; 1264; 2345<sup>2</sup>; 3016  
 (11)  
 33—2827<sup>b</sup>  
 34—1475; 1844<sup>b</sup>; 2582 (3)  
 36—609 (2); 2682  
 37—2065

## JN 11

1—2000<sup>b</sup>  
 2—2004<sup>b</sup>  
 5—2006  
 20—2005<sup>b</sup>  
 25—619 (5); 812<sup>b</sup>; 987; 2499  
 (12); 2564  
 27—2042<sup>b</sup>  
 34—2006  
 41—2432  
 44—878<sup>b</sup>; 2566  
 47—619 (5); 1860 (3)  
 52—1702; 2562

## JN 12

1—2004<sup>b</sup>  
 2—2015 (4)  
 3—2426<sup>b</sup>

JN 12—continued	JN 16	JN 19—continued
7—2005 <sup>b</sup>	2—1050	38—1664 (2)
8—2421	5—3017	39—2142 (3); 2426 <sup>b</sup>
13—2236 (3)	7—264 <sup>b</sup> ; 615 (5); 1414; 2245 (6)	JN 20
16—618	8—708; 2560 <sup>b</sup>	6—2566
20—1295; 1657 (e)	11—492 (5)	14—493 <sup>b</sup>
23—2025	12—618 <sup>2</sup> ; 1785; 2105	17—263 (2); 615; 1664 (1); 2827 (6); 2828 (11)
24—619 (5)	13—400	19—2633
31—323 <sup>b</sup> ; 2670 (1)	14—1264 <sup>b</sup>	21—1796 (2); 2199 <sup>b</sup>
32—1638; 2562; 2592 <sup>b</sup>	15—618	22—1412
34—2043 <sup>b</sup> ; 2830 (2)	24—1030	23—2350; 2569 <sup>b</sup>
41—2742 (7)	27—1932 <sup>b</sup>	24—614 (2)
42—1050	28—2345	25—2455 <sup>b</sup>
43—2429	29—2105	28—741 (2); 2344
45—2345	JN 17	31—466; 867 (2); 1286 <sup>b</sup> ; 1792 <sup>2</sup> ; 1889 (2); 2342 <sup>b</sup> ; 2343 <sup>b</sup>
46—2670 <sup>b</sup>	1—2432 (1)	JN 21
48—1705 (4)	2—323; 1890 (3)	3—1117
49—2176	3—1889 (2); 2849 (9); 3014 (6)	15—1823; 1932
JN 13	4—615 <sup>b</sup>	18—2349 <sup>b</sup>
1—3072 <sup>b</sup> ; 3073 (2)	5—609 (2); 2344 <sup>b</sup>	19—2352 (2)
2—2694 <sup>b</sup>	8—2345	22—616; 1666 <sup>b</sup>
4—1125 <sup>b</sup>	11—1263 <sup>b</sup>	25—1631
5—412 (4)	12—1766 <sup>b</sup> ; 2320 <sup>b</sup>	Acts 1
7—2485 (7)	15—1005 (4)	3—2063
14—526; 619 (5); 1929; 2670 (1)	17—2654 (6); 2683 (3)	5—394 (3); 401 (1); 2548 <sup>b</sup>
30—1658 <sup>b</sup>	19—1702; 1923 (4); 2431; 2682 (2); 2685 (1); 3026 <sup>2</sup>	6—754 (3)
34—1933 <sup>b</sup> ; 2946 <sup>b</sup>	20—1030	7—1792 <sup>b</sup>
38—2670 <sup>b</sup>	21—1264	8—966 (2); 1804 <sup>b</sup> ; 2053
JN 14	22—2344	9—263 <sup>b</sup> ; 615
1—2480	23—1703 (3) <sup>2</sup> ; 1704; 1932 <sup>b</sup>	11—494; 616; 1668 (7); 2054 <sup>b</sup>
2—615 <sup>2</sup>	26—609 (2)	12—2634
3—1706	JN 18	14—520 <sup>b</sup> ; 2002 (5); 2003 (IV)
6—323 (2); 609 (2); 987; 1261 <sup>b</sup> ; 2025; 2550 (6); 3026	1—2432	15—2112; 2668 (8); 2744
8—2368 <sup>b</sup>	3—1669	16—1479
9—323; 609 (2); 1261 <sup>b</sup> ; 2345	12.24—137 <sup>b</sup>	20—482
10—1703 <sup>b</sup> ; 2828 (11)	13—1670 (3)	25—2058
16—336 <sup>b</sup> ; 401; 1264 (8); 1413 <sup>b</sup> ; 1701; 2245 (6); 2549; 3017	19—137 <sup>b</sup> ; 1660 <sup>b</sup> ; 1670 (5)	Acts 2
18—486; 983 <sup>b</sup>	22—1845	3—2684 <sup>b</sup>
19—1011; 1700 (5)	28—1215 <sup>b</sup>	4—1415 <sup>b</sup> ; 2997 <sup>b</sup>
20—1030 (3)	29—1672 (3)	9—922 (18)
21—1261 <sup>b</sup> ; 1263	31—726; 1661 (c)	10—2622
26—618	36—655; 1803 <sup>b</sup>	14—2996 (4)
28—2345	37—1704; 1705 (4); 1803; 3026 <sup>2</sup>	16—1695
30—2670 (1); 2695	38—3025 (1)	17—401; 987; 2517 (3)
JN 15	JN 19	20—2518
1—1697; 1703 <sup>2</sup> ; 2670 <sup>b</sup>	5—1662 (3); 2344	23—2191 (5)
2—2484 (5)	7—1661 <sup>b</sup> ; 2345	24—2518 <sup>b</sup>
3—2542 (4); 2549	10—1672 (2)	27—1315 (3); 2837 <sup>b</sup>
5—1068 (4)	14—1658 (1); 1928 (4); 2437 <sup>2</sup>	28—1131
9—609 (2)	19—2123	32—615 (3); 1664 (f)
10—609 (3); 1030; 1263; 1703 <sup>b</sup>	23—878 (4)	33—265 (IX); 266 (5)
12—2946 <sup>b</sup>	25—106 <sup>b</sup> ; 519 <sup>b</sup> ; 520; 1561 (2); 2001 (4); 2002 (4)	36—619 (6); 1803; 2043 <sup>b</sup> ; 2653 (3)
13—619 (5); 1923 (4)	28—1663 (e)	38—395; 398 (2); 1786; 2350; 2558; 2559 (3); 2637 (3); 2657
16—2199 <sup>b</sup>	29—1446 <sup>b</sup>	39—388; 396 (4)
22—1701 (1)	30—2837 <sup>b</sup>	
25—2582 (3)	31—1865; 1928 (5)	
26—618; 1413 <sup>b2</sup> ; 3017	34—489; 762; 1246; 1663 (f)	

<p style="text-align: center;">Acts 2—<i>continued</i></p> <p>41—626 (4); 2567 (4); 2637 42—1283 (2); 1850; 1925 (3); 1927; 2637<sup>b</sup>; 2789<sup>b</sup> 46—69 (1); 1919 (4); 3111</p> <p style="text-align: center;">Acts 3</p> <p>2—1176<sup>b</sup> 13—2022 (2); 2043<sup>b</sup> 18—2519; 2653 (3) 19—983; 986 (2); 1786; 2546 (1); 2558<sup>b</sup>; 2657 20—616 (1); 2547 21—694; 991; 1696<sup>b</sup>; 2503; 2562 22—2022<sup>b</sup> 26—2517<sup>b</sup></p> <p style="text-align: center;">Acts 4</p> <p>1—2660 (6) 2—986<sup>b</sup> 3—726 (4) 6—90 (2) 10—2064 (3); 2653 (3) 11—619 (6) 13—1448<sup>b</sup>; 3038 18—2112<sup>b</sup> 19—2433 25—1479<sup>b</sup> 27—2022; 2043<sup>b</sup> 28—1130 (4) 34—691 36—405<sup>b</sup> 37—691</p> <p style="text-align: center;">Acts 5</p> <p>3—2842<sup>b</sup> 4—691 6—529<sup>b2</sup> 9—75<sup>b</sup> 10—529 11—651 (2) 17—726 (4) 21—2719<sup>b</sup> 30—2653 (3) 31—2558<sup>b</sup> 36—2972 37—45 (b); 2920 (4)</p> <p style="text-align: center;">Acts 6</p> <p>1—70; 479; 482 (2) 3—2057<sup>b</sup>; 2851<sup>2</sup> 5—1243 (5); 2142<sup>b</sup>; 2368<sup>b</sup> 9—94 (3) 13—1660<sup>b</sup> 15—2852 (5); 3005<sup>b</sup></p> <p style="text-align: center;">Acts 7</p> <p>2—2852; 2853 (6) 4—18 (II) 6—911 (6) 22—463 (1b); 2084<sup>b</sup>; 2702<sup>b</sup>; 3096<sup>b</sup></p>	<p style="text-align: center;">Acts 7—<i>continued</i></p> <p>37—2022<sup>b</sup> 38—1847 (1) 48—310 (8) 51—2854 53—2023 55—615<sup>b</sup> 58—2271 (2); 2278<sup>b</sup></p> <p style="text-align: center;">Acts 8</p> <p>1—2368<sup>b</sup> 2—529<sup>b</sup> 7—2844 9—3097 (1) 12—482 (2) 17—401<sup>b</sup> 27—768<sup>b</sup>; 1032 (3) 30—2022 (2) 32—619 (6); 882 35—2043<sup>b</sup> 37—742 38—390</p> <p style="text-align: center;">Acts 9</p> <p>1—2278; 2362<sup>b</sup> 4—1797 5—2279 7—882 8—2279<sup>b</sup> 11—2916 (8) 18—1070; 2701<sup>b</sup> 20—2287<sup>b</sup>; 2828 (10) 30—2275; 2280<sup>a</sup> 35—2558 (3) 37—529<sup>b</sup> 43—736 (17); 2908<sup>b</sup></p> <p style="text-align: center;">Acts 10</p> <p>1—2622 6—736 (17); 2908<sup>b</sup> 11—401 15—520; 819; 1879<sup>b</sup> 25—61 (5) 28—1215<sup>b</sup> 34—2350 36—2043<sup>b</sup> 38—1411; 2022 43—619 (6); 1786 46—2996<sup>b</sup></p> <p style="text-align: center;">Acts 11</p> <p>1—2060; 2281 (4) 3—1215<sup>b</sup> 15—2996<sup>b</sup> 16—394 (3); 2548 18—401 19—206 (1); 2368<sup>b</sup> 20—486<sup>b</sup>; 1796 (3) 26—621 (1) 27—479<sup>b</sup>; 622 (3) 30—2437</p>	<p style="text-align: center;">Acts 12</p> <p>4—2513 12—1986<sup>b</sup>; 2006 (VI) 17—2349<sup>b</sup></p> <p style="text-align: center;">Acts 13</p> <p>1—45; 479 5—2662 (3); 1986<sup>b</sup> 6—404<sup>b</sup> 7—45; 2620 (1) 9—2278 13—1987 14—2633 24—2558<sup>b</sup> 32—2518 35—1478<sup>b</sup> 38—619 (6) 43—2348; 2468 (3) 44—2350<sup>b</sup> 50—45 51—1125<sup>b</sup></p> <p style="text-align: center;">Acts 14</p> <p>2—65 6—45; 2576 9—2278 11—1944 (2) 12—2277 13—45 14—2058 15—1260 (3); 2256 17—2574 20—831 (3) 21—2922 (II) 23—2437 (2)</p> <p style="text-align: center;">Acts 15</p> <p>1—482 (2); 2282 (6) 2—204; 2437 (2) 4—480 (3) 7—721<sup>b</sup> 9—2370 (3) 10—2625 (2); 2943 11—2350 13—1561<sup>b</sup> 20—1796 (3); 2469 (4) 21—2468 (2) 28—1920 (5); 2631 (4) 29—2142<sup>b</sup> 35—2278<sup>b</sup> 39—1987; 2662 (3) 41—2280 (3)</p> <p style="text-align: center;">Acts 16</p> <p>1—831 (3) 3—657<sup>b</sup> 4—480 (3) 6—2283<sup>b</sup> 12—2371 13—2633; 2878 (1) 14—1943<sup>b</sup>; 2977<sup>b</sup>; 3127 (2) 15—396 (4) 16—296 (1); 689 (1); 2511<sup>b</sup></p>
--	--	---

## Acts 16—continued

17—2370

20—45

22—661<sup>b</sup>

35—45; 1672 (2)

## Acts 17

3—619 (6)

4—2966<sup>b</sup>5—1880<sup>b</sup>

6—45

7—2606

9—2712

16—2275 (4)

17—320

18—348<sup>b</sup>; 964; 1272<sup>2</sup>; 2855 (5)

22—2871

23—1260 (3); 3037<sup>b</sup>

25—3112

26—147<sup>b</sup>; 1093<sup>b</sup>27—1012<sup>b</sup>; 2191<sup>b</sup>; 257428—59 (3); 146<sup>b</sup>; 309; 609 (1);692<sup>b</sup>; 1262; 1451; 2190 (3);

2480; 2836

29—1252 (3); 1269

30—2043<sup>b</sup>; 2549 (2); 2559<sup>b</sup>;

2799 (6)

31—1783; 2340<sup>b</sup>

## Acts 18

2—1626 (b)

3—2967

4—2633

j—667<sup>b</sup>

8—396 (4)

12—45; 2596; 2620

14—207 (4)

18—2285 (9); 2386

25—394 (3)

## Acts 19

1—1710 (3)

3—389<sup>b</sup>4—2558<sup>b</sup>

5—742

6—401<sup>b</sup>; 2996<sup>b</sup>

8—2348

10—2977<sup>b</sup>

11—2844

12—876<sup>b</sup>

13—1068

19—300 (3)

21—1155; 2615 (2)

29—1173 (4)

31—45; 282

33—90 (3)

35—308<sup>b</sup>; 300137—2942<sup>b</sup>

39—651

## Acts 20

2—1450 (4)

7—1919 (3); 2633

## Acts 20—continued

15—2051<sup>b</sup>16—3111<sup>b</sup>17—480 (3); 653<sup>b</sup>; 958 (3); 1837(2); 2967; 3023<sup>b</sup>

19—2943

21—1783 (3); 2558; 2657

24—1281

29—1445 (6)

30—2259 (1)

32—2682<sup>b</sup>35—1910<sup>b</sup>; 2844<sup>b</sup>37—2129<sup>b</sup>

## Acts 21

8—480 (4)

9—2058<sup>b</sup>13—2657<sup>b</sup>20—207; 1847<sup>b</sup>21—2125<sup>b</sup>

23—2278

25—2469 (4)

26—2652 (1)

28—3023 (2)

29—2253<sup>b</sup>

39—661 (2); 2916 (8)

## Acts 22

3—1859<sup>b</sup>; 2916 (8)6—1891<sup>b</sup>10—2279<sup>b</sup>16—393; 395; 2684<sup>b</sup>

20—2851 (2)

21—2291 (2); 2480

23—883

24—1672 (2)

25—2704

28—661<sup>b</sup>; 2273 (2)

## Acts 23

1—129 (3); 661 (3)

5—1070; 2974

6—973 (2); 2278

8—163 (4); 2363 (3); 2659; 2660

11—208

24—2458

25—967 (6)

27—2614

35—2428 (1)

## Acts 24

1—2458

2—2477

5—622 (2); 2123

6—2253<sup>b</sup>; 3023 (2)10—1105<sup>b</sup>15—99<sup>b</sup>; 976 (5)25—881 (3); 2929<sup>b</sup>

27—2374 (V)

## Acts 25

10—1672 (2)

11—2138; 2614

14—2606

## Acts 26

5—2557; 2864

9—707 (2)

10—2271 (2); 2278<sup>b</sup>

11—1961 (2)

13—2279

14—1248<sup>b</sup>; 1796; 2278 (7)18—398; 2682<sup>b</sup>; 2695

20—2558 (3)

25—2820<sup>b</sup>28—100<sup>b</sup>; 2348

30—2458

## Acts 27

9—327

11—745 (5)

14—1039<sup>b</sup>; 3086 (5)17—2886<sup>b</sup>

## Acts 28

2—403

4—2277<sup>b</sup>7—45<sup>b</sup>; 25018—884<sup>b</sup>

10—1350 (3)

13—2510<sup>b</sup>

15—2622 (1)

16—258<sup>b</sup>30—1284<sup>b</sup>

31—537 (4)

## Rom 1

1—2058

3—742; 2023<sup>b</sup>; 2340<sup>b</sup>

4—53 (3); 623 (2); 1664 (f);

2043<sup>b</sup>; 2569 (8); 2656 (2)5—2175<sup>b</sup>; 2657; 2669<sup>b</sup>

7—2292 (1)

10—319

13—206<sup>b</sup>; 982<sup>b</sup>

14—815

15—1040

16—1281

17—2519<sup>b</sup>18—1042; 1135<sup>b</sup>; 1260 (3); 2023;2570 (3); 2571 (6); 2655<sup>b</sup>;2656; 3026<sup>b</sup>20—1015 (1); 1269<sup>2</sup>; 2191<sup>b</sup>; 2430

(3); 2574; 2575

21—2429

23—1239 (3)

25—302<sup>b</sup>28—2560<sup>b</sup>

## Rom 2

3—2571 (6)

4—2559<sup>b</sup>; 2657

5—2502; 2570 (2)

7—1461

9—2837<sup>b</sup>

13—1782; 1848 (2)

15—708; 1093<sup>b</sup>

16—990; 2287 (VI)

Rom 2— <i>continued</i>	Rom 6— <i>continued</i>	Rom 9
19—2468 <sup>b</sup> 22—2942 <sup>b</sup> 28—2696 <sup>b</sup> 29—2429	3—2684 <sup>b</sup> 4—387; 390; 394; 615; 652 <sup>2</sup> ; 742 <sup>b</sup> ; 2668; 2685 (8) 5—2564 6—493 (3); 1975 (3); 2024; 2685 (1) 7—1849 (9) 11—398 (1); 1070 12—492 (2) 13—2658 (4) 14—2509 17—205 (a) 19—1003 (7) 23—493	3—130 4—59 (1); 610 (5); 2556 <sup>b</sup> 5—2023 <sup>b</sup> ; 2090 (1); 2340 <sup>b</sup> ; 2617 (3); 3018 <sup>b</sup> 7—2519 <sup>b</sup> 10—2535 11—925 <sup>b3</sup> ; 1130; 1549 <sup>b</sup> 14—2435 <sup>b</sup> 18—927; 1338 <sup>b</sup> 20—926 <sup>2</sup> ; 2426 <sup>b</sup> 22—2571 (6) 30—2669 <sup>b</sup> 32—458 (4)
Rom 3		
1—2668 (1) 2—1478 (8) 3—1090 (2) 8—2291 (5); 2485 (7) 9—322 (3) 10—1782 <sup>b</sup> 19—708; 926; 1847 (3); 2582 (3) 20—1784 (5); 2559 21—1464 (3); 1880; 2287 <sup>b</sup> ; 2288 22—1783 (3) 24—323; 1291 (3); 1292 (7); 2024; 2653; 2655 (2) 25—620; 1133; 1135 <sup>b</sup> ; 2023 <sup>b</sup> ; 2177; 2467; 2656; 2669 (6); 2892 (3) 26—692 <sup>b</sup> ; 1782 <sup>b</sup>	Rom 7	Rom 10
Rom 4	Rom 7	Rom 10
4—1291 (3) 5—1465; 1784; 2669 <sup>b</sup> 6—419 (1) 7—2654 <sup>b</sup> 8—1462 <sup>b</sup> 11—399; 2709 <sup>b</sup> 13—2574 14—2339 <sup>b</sup> 15—1848 (6); 2571 (6) 25—1783 <sup>b</sup> ; 2569 (8)	1—1849; 2291 (3) 4—2669 <sup>2</sup> 7—493 (3); 2278 (7); 2289 (2) 13—1783 22—1975 (2) 23—398 (1); 2454 <sup>b</sup> ; 2541 <sup>2</sup> 24—493 <sup>2</sup> ; 2670 (8) 25—2056 (2); 2292 (6)	3—1465 <sup>b</sup> 4—1851; 2291 (1) 6—1914 (1) 9—742 13—2669 <sup>b</sup> 17—399 18—982 <sup>b</sup>
Rom 5	Rom 8	Rom 11
1—2467 (2); 2669 (6) 3—2670 (8) 4—1068 <sup>b</sup> 5—525 (2); 1783 <sup>b</sup> ; 1933 (1); 2845 (2) 5.8—1262 6—2669 <sup>b</sup> 8—2655 <sup>b</sup> ; 2656 9—2536 <sup>b</sup> ; 2571 (6); 2668 (1) 10—1135 (12); 2023 <sup>b</sup> ; 2654 (2) 11—321 <sup>b</sup> ; 2537 (d) 12—322 <sup>b</sup> ; 973 (3); 1093; 2498(9) <sup>2</sup> 13—1310 14—3029 (3) 17—1463 <sup>b</sup> 18—991; 1464 <sup>b</sup> ; 1465; 2657; 2800 (9) 19—2176 (3) 20—1048; 1291 (3); 1848 (6); 2292 21—2340	1—599; 1849; 1974 (3); 1975 (1); 2715 <sup>b</sup> ; 2800 2—615; 1416 <sup>b</sup> ; 2495 (2); 2541 <sup>b</sup> ; 2550 3—1119 <sup>b</sup> ; 1783; 1880; 2040 <sup>b</sup> ; 2291 (5); 2548 (3) 7—2023 <sup>b</sup> ; 2721 9—925 (III); 2542 (4); 2544; 2669 <sup>2</sup> ; 2684 <sup>4</sup> 10—987 (3); 1461 (2); 2550 11—620; 987 (3); 2564 12—59 13—2669 (3); 2670 (8) 14—608; 610 15—2556 <sup>b</sup> ; 2683 (2); 2842 <sup>2</sup> 16—2274; 2842 <sup>b</sup> ; 3035; 3099 17—609 (2); 2654 (7) 19—988; 2801 (11) 21—60; 495 (2); 1881 <sup>b</sup> ; 2548 <sup>b</sup> 22—981 (2); 2542 (3) 23—973 (3); 1416 24—2668 (1) 26—1374; 1487 <sup>b</sup> ; 2617 <sup>b</sup> 28—2480 <sup>b</sup> ; 2482 (3) 29—625; 927; 1130; 1131; 1451; 2435 (4) 30—2799 (5) 31—2329; 2592 <sup>b</sup> 32—2655 <sup>b</sup> ; 2801 (12) 33—1784 (5) 34—264; 615 <sup>b</sup> ; 1783 <sup>b</sup> ; 2024 35—2543 <sup>b</sup> 37—701 38—2454 <sup>b</sup> 39—1263; 2686 (2)	Rom 11
Rom 6	Rom 14	Rom 12
1—2292 (2); 2617 (5); 2670 (8); 3011 (II) 2—2291 (5); 2669 (4)	Rom 14	2—1130 4—925; 2581 5—1291 (3) 8—2842 9—2864; 2898 <sup>b</sup> 17—2185 (5); 3091 <sup>b</sup> 24—1293 25—458 <sup>b</sup> ; 983; 1090 <sup>b</sup> ; 2105 <sup>b</sup> 26—2519 <sup>b</sup> ; 2668 (1) 28—2537 (c) 29—545 <sup>b</sup> 30—3033 32—2562; 2657 33—926 36—740 (4); 2480 <sup>b</sup> Rom 12 1—2446 (3); 2498 (10); 2657 <sup>b</sup> ; 2845 2—1098 <sup>b</sup> ; 2801 (11); 3006; 3109 5—652 (2); 2292 (1) 6—2059; 2843 <sup>b</sup> 8—479; 2060; 2844 <sup>b</sup> 13—1433 (7); 2427 (4) 19—3113 (2) 20—1024 <sup>b</sup> Rom 13 1—1850; 2138 3—2429 8—814; 1849 (13); 1933 <sup>b</sup> ; 2291 (1) 10—2668 (2) Rom 14 5—1920 (5) 8—2683 (2)

ROM 14—*continued*

10—616 (2)  
12—33  
13—881<sup>b</sup>  
15—1933<sup>b</sup>  
20—819  
23—1309<sup>b</sup>

## ROM 15

4—1481 (14)  
8—1090 (2)  
10—1478<sup>b2</sup>  
16—2657 (3); 2683  
18—2844  
19—982<sup>b</sup>; 1449<sup>2</sup>  
23—206 (2)  
24—2260  
26—2427 (4)  
28—2709<sup>b</sup>

## ROM 16

1—1433 (7); 2614 (2); 3103 (6)  
2—2060; 2662  
6—2001 (5)  
7—132 (a); 2058  
8—432  
10—538 (7)  
11—2120  
13—90 (1); 2625<sup>b</sup>  
18—492 (1)  
19—2798  
20—2129; 2695  
22—1070  
23—1433 (6); 2854  
25—2105

## 1 COR 1

2—652 (4); 2593; 2682 (2);  
2683<sup>2</sup>; 2685 (1)  
3—2043<sup>b</sup>  
8—2292 (1)  
12—201  
13—389  
14—397 (5)  
16—396 (4)  
17—2339<sup>b</sup>  
18—761<sup>b</sup>; 2427<sup>b</sup>  
22—2789<sup>b</sup>  
23—626 (4)  
30—618; 1465; 2024

## 1 COR 2

1—2105; 2967<sup>b</sup>  
5—1444 (5)  
6—3091<sup>b</sup>  
10—3020<sup>b</sup>  
12—2686; 2845 (1)  
13—461; 2580<sup>b</sup>  
14—1816; 2721; 2845<sup>b</sup>  
15—1957 (1)  
16—2056; 2684<sup>b2</sup>

## 1 COR 3

1—1119; 1975 (1); 2105; 2682<sup>b</sup>;  
2842<sup>b</sup>  
2—2052  
4—201  
13—799; 2669  
14—2658  
15—990  
17—2670 (8)  
21—691

## 1 COR 4

5—2429; 2572 (11); 2669  
6—1110  
8—1173 (4)  
9—1179<sup>b</sup>  
12—1133 (2)  
13—2180<sup>b</sup>  
15—399; 2702<sup>b</sup>  
17—1023

## 1 COR 5

1—1051  
5—654 (4); 2670 (8)  
7—798<sup>b</sup>; 889; 1823; 1923 (4);  
2024; 2653; 2685 (8)  
9—195  
10—1005 (4)

## 1 COR 6

1—2353 (1)  
7—818; 877<sup>b</sup>  
9—2250 (4)  
11—395; 2548<sup>b</sup>; 2684<sup>b</sup>  
13—2564<sup>b</sup>; 2565  
16—1478<sup>b</sup>  
17—2550  
19—2669 (3); 2892 (1)  
20—2024; 2532

## 1 COR 7

7—2278<sup>b</sup>  
8—1038 (4)  
9—2929<sup>b</sup>  
10—1999 (5); 2290 (1)  
11—2536<sup>b</sup>  
12—2682<sup>b</sup>  
14—393<sup>b</sup>  
15—866 (2); 1999<sup>b</sup>  
23—2024; 2532  
26—981 (2)  
35—2819

## 1 COR 8

1—1242 (2)  
3—1130  
4—3014 (6)  
5—2023; 2326 (18)  
6—1914 (1); 2024; 3019  
8—881<sup>b</sup>  
9—2867  
11—2329  
13—716

## 1 COR 9

1—203 (4); 2279  
2—2709<sup>b</sup>  
5—519; 520<sup>b</sup>; 2278<sup>b</sup>; 2349<sup>b</sup>  
9—2102<sup>b</sup>  
10—2409<sup>b</sup>  
15—2339<sup>b</sup>  
16—2433 (3)  
24—1172 (e); 1173  
26—88; 1172<sup>b</sup>  
27—492 (2); 1172 (g); 2329;  
2560<sup>b</sup>; 2669

## 1 COR 10

1—395 (3); 2637  
2—394 (3)  
4—2843; 2845  
5—2292 (2)  
11—980  
12—2669<sup>2</sup>  
13—1090<sup>b</sup>; 2943  
14—1448  
16—487<sup>b</sup>; 688 (1); 1659; 1927<sup>b</sup>  
17—1728 (d)  
20—690 (3); 2292 (2)  
21—2898<sup>b</sup>

## 1 COR 11

2—3004 (2); 3047  
5—1348 (6)  
7—146 (4); 989; 1451 (2);  
1914 (1)  
8.9—53 (4)  
10—134 (6)  
15—733  
20—70 (5)  
21—880<sup>b</sup>  
23—70; 618; 2789<sup>b</sup>  
24—1659; 1929; 2022; 2637 (2)  
25—731 (2); 2653 (2)  
26—2658  
27—1310; 1922 (3)  
28—1929  
29—1927 (c); 2292 (2)  
30—992 (6); 2670 (8)

## 1 COR 12

3—130; 624 (2); 2684 (5)  
4—3019 (16)  
10—2844<sup>3</sup>; 2996  
12—2030; 2542 (3)  
13—389; 401; 492 (2); 2548<sup>b</sup>  
18—2497  
24—2929  
27—652  
28—2843

## 1 COR 13

1—2996<sup>b</sup>  
2—467 (c); 1242 (2)  
3—744  
4—1439<sup>b</sup>  
11—2997 (5)  
13—1420 (4)



1 COR 14

1—2059  
 2—2996 (1)  
 5—1415<sup>b</sup>  
 9—88<sup>b</sup>  
 11—402<sup>b</sup>  
 18—2997 (5)  
 21—2582 (3)  
 23—1448<sup>b</sup>  
 24—3112  
 26—2059  
 29—2843<sup>b</sup>  
 37—1483<sup>2</sup>; 1975 (1); 2580 (6)  
 40—655 (5); 816

1 COR 15

1—2569 (8)  
 3—323<sup>b</sup>; 623; 742; 1664 (*f*);  
 2291 (4); 2568; 2569 (8)  
 5—928 (11)  
 6—2668 (8)  
 7—520<sup>b</sup>  
 13—399  
 15—2054  
 17—2367<sup>b</sup>  
 21—811<sup>b</sup>; 973 (3); 1463; 2340<sup>b</sup>;  
 2503  
 22—53 (2); 991; 1093; 2023<sup>b</sup>;  
 2498 (9); 2562; 2684  
 23—987; 1315; 2249 (1); 2565  
 24—1805; 2023<sup>b</sup>; 2053<sup>b</sup>; 2504 (5)  
 27—2546 (1)  
 29—392 (2); 397 (6); 2292 (2)  
 31—2686  
 32—189 (3); 1172 (3)  
 35—615; 988<sup>b</sup>; 2089 (6)  
 37—1461 (3)  
 40—587<sup>b</sup>  
 41—307 (3)  
 44—492 (4); 493<sup>b</sup>; 1451; 2338  
 45—50; 53 (3); 1914 (1); 2495  
 (2); 2497<sup>b</sup>  
 46—1975 (1); 2121<sup>b</sup>  
 47—989<sup>b</sup>; 1015; 2340<sup>b</sup>  
 49—988  
 50—1119 (5); 1804<sup>b</sup>; 2105<sup>b</sup>;  
 2250 (4); 2564  
 52—257  
 54—2582 (3)

1 COR 16

1—2633  
 2—1919 (3)  
 8—3111  
 12—201  
 22—1051

2 COR 1

1—2685 (1)  
 4—1481; 2245 (2)  
 8—2969  
 10—2670 (8); 2694<sup>b</sup>

2 COR 1—*continued*

20—1090<sup>b</sup>  
 22—1416<sup>b</sup>; 2709<sup>b2</sup>  
 23—2173 (4)

2 COR 2

5—1051  
 6—2670 (8)  
 11—2694<sup>b</sup>  
 14—257; 2818; 3022<sup>b</sup>  
 15—2700<sup>b</sup>

2 COR 3

3—3114<sup>b</sup>  
 5—398 (1); 733 (9)  
 9—1465  
 15—1285 (VII)  
 17—1264 (8); 2669 (4); 2684<sup>b2</sup>  
 18—988; 1451; 2288; 2851 (4)

2 COR 4

2—2105  
 4—1451<sup>2</sup>; 2023; 2694<sup>b</sup>; 3109  
 6—399; 1451 (2); 2279 (3)  
 7—719; 853 (6); 988; 2202<sup>b</sup>;  
 2426<sup>b</sup>; 2497 (3)  
 10—2564  
 16—145 (b); 1974 (2); 1975 (2)  
 17—988

2 COR 5

1—146 (5); 719; 988<sup>2</sup>; 989  
 (VII); 2497 (3); 2564 (4)  
 2—670; 992 (6)  
 3—2563 (5)  
 6—1315  
 8—1461  
 10—990<sup>b</sup>; 2502<sup>2</sup>; 2669  
 11—2348; 2949<sup>b</sup>  
 14—1933 (1); 2657<sup>2</sup>  
 16—2279; 2287<sup>b</sup>; 2289 (3)  
 17—398 (1); 742; 2548 (3);  
 2550<sup>2</sup>; 2633; 2669 (4)  
 18—321<sup>b</sup>; 620 (2); 1135 (12);  
 2023<sup>b</sup>; 2467; 2537 (2)  
 19—323<sup>b</sup>; 1135<sup>b</sup>; 2655<sup>b</sup>  
 20—115; 2434 (9)  
 21—72 (2); 1464; 1465; 1630<sup>b</sup>;  
 2040<sup>b</sup>; 2654 (5); 2656

2 COR 6

2—1478<sup>b</sup>; 2502<sup>b</sup>  
 10—2427 (3)  
 11—2093  
 16—2892 (1)

2 COR 7

1—323; 2685<sup>2</sup>  
 8—2558<sup>b</sup>  
 9—2559<sup>2</sup>  
 10—1133 (4)  
 14—388

2 COR 8

2—2373 (4)  
 5—2657 (3)  
 9—2043<sup>b</sup>; 2340 (2); 2427  
 16—3023<sup>b</sup>  
 18—406; 1936<sup>2</sup>; 2394; 2429

2 COR 9

3—2339<sup>b</sup>  
 9—2427 (3)

2 COR 10

3—257  
 4—2789  
 9—2267<sup>b</sup>; 2277<sup>b</sup>

2 COR 11

3—492 (5); 3101 (7)  
 8—2373 (4)  
 14—2184  
 15—2694<sup>b</sup>  
 24—661<sup>b</sup>  
 25—2777 (3)  
 26—2401 (2)  
 32—218

2 COR 12

4—2281 (4)  
 6—734  
 7—1070; 2670 (8); 2694 (3);  
 2974  
 8—2432 (2)  
 9—1292 (7)  
 11—2350  
 16—1309

2 COR 13

2—2267<sup>b</sup>  
 4—2842  
 5—2560<sup>b</sup>  
 11—1023 (1)  
 14—435<sup>b</sup>; 742; 1417; 2023<sup>b</sup>;  
 3019; 3020

GAL 1

10—2348; 2429  
 11—2281 (4)  
 12—1999 (5)  
 15—1457<sup>b</sup>; 1481<sup>b</sup>  
 19—519  
 20—2173 (4)  
 21—2275

GAL 2

4—495 (2)  
 5—3026  
 6—1461; 2966<sup>b</sup>  
 7—2058  
 10—2427 (4)  
 11—2278<sup>b</sup>; 2350  
 12—207 (3)  
 20—323<sup>b</sup>; 2024; 2291 (5); 2548<sup>b</sup>;  
 2550 (6); 2656 (2); 2669 (4);  
 2683 (2); 2684<sup>b</sup>; 2685 (1)

**GAL 3**  
 1—3097<sup>b</sup>  
 2—1850  
 6—1465<sup>b</sup>  
 7—399  
 8—1089  
 11—1313 (2)  
 13—761 (4); 2024; 2289 (3);  
 2532<sup>2</sup>; 2541; 2654; 2655<sup>b</sup>;  
 2656  
 14—2657; 2669 (3)  
 15—729<sup>b</sup>; 1464; 1927 (2)  
 16—1478<sup>b2</sup>; 2363 (6); 2519<sup>b</sup>;  
 2712<sup>b</sup>;  
 19—616<sup>b</sup>; 1782<sup>b</sup>; 2023  
 21—1783 (1)  
 23—59 (1)  
 24—865; 1020 (1); 2702<sup>b</sup>  
 26—2836  
 27—389; 398 (2); 2670 (8)  
 28—1106<sup>b</sup>; 2817 (6)

**GAL 4**  
 2—1850; 2854  
 3—495 (2); 1783; 2625 (2)  
 4—492 (4); 610 (5); 626; 1149;  
 1464; 1627; 2023<sup>b</sup>; 2340<sup>b</sup>  
 5—59 (1); 2024; 2274; 2532;  
 2556; 2654  
 6—609 (2); 2550 (4); 2669 (4);  
 2683 (2)  
 9—426  
 10—1920 (5)  
 12—2974  
 14—2277  
 17—65<sup>b</sup>  
 19—2684<sup>b</sup>  
 21—21; 98; 1317 (6); 1510 (6);  
 2292 (6)  
 22—1490 (3); 2691<sup>b</sup>  
 24—2277  
 25—1317 (6)  
 29—1509 (3)

**GAL 5**  
 1—58 (II); 495 (2)  
 3—2469 (4)  
 5—990<sup>b</sup>  
 6—467 (c); 1567; 1784; 2631  
 (4); 2657  
 7—3026  
 11—2867<sup>b</sup>  
 13—627 (2)  
 16—401; 2669 (3); 2685<sup>2</sup>  
 17—1119<sup>b</sup>  
 19—1042; 1416<sup>b</sup>  
 20—1377  
 21—881; 2250 (4); 2669  
 22—1918; 1933 (1); 2261<sup>b</sup>; 2291  
 (1); 2357 (1); 2509 (6);  
 2684<sup>b</sup>  
 24—761<sup>b</sup>; 2668 (2)

**GAL 6**  
 1—1975 (1); 2670 (8); 2801 (13);  
 2842  
 6—2292 (1)  
 7—67 (5); 2502; 2570  
 8—692<sup>b</sup>; 722<sup>b</sup>; 987 (3)  
 11—2974  
 14—761<sup>b</sup>; 2024  
 15—398 (1); 742<sup>b</sup>; 2548 (3)  
 16—925<sup>b</sup>  
 17—2455<sup>b</sup>

**EPH 1**  
 1—1837<sup>b</sup>  
 3—1130<sup>2</sup>  
 4—613 (2); 2435 (4)  
 5—2556<sup>b</sup>  
 7—2024; 2531<sup>b</sup>; 2541; 2634;  
 2654  
 8—467 (1)  
 9—2562  
 10—957; 991; 1094; 2503; 2504;  
 2654 (2).  
 13—2709<sup>2</sup>  
 14—401<sup>b</sup>; 2550 (4)  
 18—3025<sup>b</sup>  
 19—615; 1023<sup>b</sup>  
 20—264; 615<sup>b2</sup>  
 22—2030  
 23—1140

**EPH 2**  
 1—801 (7); 812; 2548 (3)  
 2—88<sup>b</sup>; 2497 (7)  
 3—399 (4); 1975 (1); 2056; 2571  
 (6); 2668 (2); 2798 (3)  
 5—398 (1)  
 6—264; 615; 1933; 2564  
 8—926  
 11—957<sup>b</sup>; 1838 (3)  
 12—2574  
 13—2654 (2)  
 14—3023<sup>b</sup>  
 15—953  
 16—761<sup>b</sup>; 2023; 2538 (3)  
 19—1804<sup>b</sup>; 2273 (2)  
 20—482 (1)

**EPH 3**  
 1—956 (2)  
 3—101; 2105  
 5—467 (1)  
 10—2454<sup>b</sup>; 2455  
 11—692 (3); 2435<sup>b</sup>  
 13—1238 (2)  
 14—1101  
 15—2548<sup>b</sup>  
 16—1975 (2)  
 18—517  
 19—1914 (1)  
 20—2189 (6)  
 21—1199<sup>b</sup>; 1892 (4)

**EPH 4**  
 1—956 (2); 2683  
 4—1914 (1)  
 5—394  
 6—1262; 2288  
 8—264; 265 (IX); 1478<sup>b</sup>  
 9—2340<sup>b</sup>  
 13—610<sup>b</sup>; 1023; 1149  
 15—2030; 2684<sup>b</sup>; 3026<sup>b</sup>  
 16—492 (3)  
 17—2548<sup>b</sup>; 2668 (2)  
 18—2056; 3025<sup>b</sup>  
 21—3025<sup>b</sup>  
 22—399; 1975 (3)  
 23—2842  
 24—146 (5)  
 26—3113 (4)  
 29—533  
 30—2709<sup>b2</sup>; 2842<sup>b</sup>  
 32—1024<sup>b</sup>

**EPH 5**  
 1—609 (3); 3099<sup>b</sup>  
 2—2024; 2291<sup>2</sup>; 2685 (8); 2700<sup>b</sup>;  
 2818  
 3—2662  
 4—1624  
 5—2250  
 6—2023<sup>b</sup>; 2571 (6)  
 14—1478<sup>b</sup>  
 18—401; 881  
 19—2845  
 22—2509 (6)  
 23—2030  
 25—651 (3)  
 26—394 (4); 395<sup>2</sup>; 398 (2); 399;  
 652 (4); 2684<sup>b</sup>  
 27—3114  
 32—2105; 2636<sup>b</sup>

**EPH 6**  
 4—397<sup>b</sup>; 2280 (3)  
 5—2817 (6)  
 6—1070<sup>b</sup>  
 12—492 (4); 1173 (i); 1352<sup>b</sup>;  
 2842<sup>b</sup>  
 15—2437  
 16—2789  
 18—2328  
 19—2093; 2105

**PHIL 1**  
 7.12—2374  
 12—2484 (6)  
 13—2259<sup>b</sup>; 2374<sup>b</sup>; 2427<sup>b</sup>; 2429;  
 2622<sup>b</sup>  
 21—1461  
 23—992 (6); 1315  
 27—661 (3); 2372<sup>b</sup>; 2497  
 28—2320  
 29—2657 (2)

- PHIL 2**  
 2—2497 (7)  
 5—336<sup>b</sup>; 2338 (1); 2374 (4);  
 2658 (4); 2683 (3); 2684<sup>b</sup>;  
 3056 (3)  
 6—264 (3); 420; 615<sup>b</sup>; 1293;  
 2023<sup>b</sup>; 2176 (2); 2457<sup>b</sup>;  
 3035  
 7—1632<sup>b</sup>; 1667; 1792<sup>2</sup>  
 9—468 (2); 2504 (5)  
 12—2685 (8)  
 13—398  
 19—2260<sup>b</sup>  
 20—2374  
 22—2985 (21)  
 24—2366 (1)
- PHIL 3**  
 1—657 (3); 696<sup>b</sup>; 2370<sup>b</sup>  
 5—1850<sup>b</sup>; 2276 (5); 2469  
 6—2291  
 9—987; 1465  
 10—2024; 2564; 2654 (6); 2657<sup>b</sup>  
 12—988; 2290 (4); 2669; 2686 (2)  
 13—1461<sup>b</sup>  
 14—545<sup>b</sup>; 1172 (f); 2457<sup>b</sup>  
 18—761<sup>b</sup>  
 20—264 (3); 615; 661 (3); 988<sup>b</sup>;  
 989<sup>b</sup>; 2273 (2); 2372<sup>b</sup>  
 21—493<sup>b</sup>; 973 (3); 1317 (6);  
 1451; 1796; 2338; 2564
- PHIL 4**  
 3—3103 (4); 3127 (1)  
 4—2374  
 8—2429<sup>b</sup>  
 12—3; 2275 (4)  
 13—2669 (4)  
 15—2373 (4)  
 18—2658 (4); 2700<sup>b</sup>; 2818; 2845  
 22—537
- COL 1**  
 6—982<sup>b</sup>  
 7—955  
 9—2056<sup>b</sup>  
 11—1918<sup>b</sup>  
 13—2250 (4); 2532<sup>b</sup>  
 14—2024  
 15—1113<sup>b</sup>; 1450 (2); 1451 (3);  
 1914<sup>b</sup>; 2023<sup>b</sup>; 2288; 3020<sup>b</sup>  
 16—2455; 2481  
 18—426<sup>b</sup>; 2290 (1)  
 19—1149; 2341  
 20—323; 761<sup>b</sup>; 991; 2538 (4);  
 2562  
 21—1135 (12); 2023<sup>b</sup>  
 24—67 (5); 2657 (3)  
 25—467 (1)  
 26—2105<sup>2</sup>; 2550 (5)  
 27—1247 (8); 1461 (2)
- COL 2**  
 1—1119 (8)  
 2—2105  
 3—1914 (1)  
 5—257  
 6—2685 (8)  
 8—207 (5); 2383; 2625; 3004 (3)  
 9—1264 (8); 1269<sup>b</sup>; 1451 (4); 2341  
 10—1149 (3)  
 11—396; 677<sup>b</sup>; 1633 (2); 2292 (2)  
 12—387; 390; 391<sup>b</sup>; 2670 (8)  
 15—2289 (1); 3022<sup>b</sup>  
 16—1920 (5); 2631 (4)  
 18—1440; 2056; 2557  
 19—2273 (2)  
 20—2288  
 21—197 (2); 1242 (1)
- COL 3**  
 1—398<sup>b</sup>; 2683  
 3—988<sup>b</sup>; 2024; 2550  
 5—1448; 2030; 2256; 2668 (2)  
 6—2023<sup>b</sup>; 2571 (6)  
 9—1887 (2); 1975 (3); 2669  
 10—146 (5); 1451; 2548<sup>b</sup>  
 11—402<sup>b</sup>  
 12—1404 (4)  
 15—1173  
 16—2845  
 22—1070<sup>b</sup>
- COL 4**  
 10—1939 (4)  
 16—195; 958 (4); 1837 (3); 2267<sup>b</sup>
- 1 THESS 1**  
 1—2567  
 2—3019 (16)  
 3—990<sup>b</sup>  
 4—2292 (1)  
 9—707 (2); 2054<sup>b</sup>; 2558 (3)  
 10—264 (4); 2571 (6)
- 1 THESS 2**  
 2—2370  
 4—2434 (2)  
 6—2429  
 8—2841 (1)  
 13—2669<sup>b</sup>  
 15—2567 (5)  
 16—2571 (6)  
 17—2967  
 18—1571<sup>b</sup>; 2694 (3)  
 19—2249  
 20—1238 (2)
- 1 THESS 3**  
 3—981 (2)  
 9—2969  
 11—2567 (5)  
 12—2685  
 13—986; 2684 (7)
- 1 THESS 4**  
 1—2669  
 3—2684 (5); 2685 (8); 2967<sup>b</sup>  
 4—3049  
 6—2571 (7)  
 8—2669 (3)  
 13—380<sup>b</sup>; 987; 992  
 14—283; 2567 (5)  
 15—2457  
 16—981 (1); 986; 1315; 2564 (4);  
 2565; 2777 (3)  
 17—989; 2054
- 1 THESS 5**  
 2—986 (4)  
 3—981 (2)  
 6—2820<sup>b</sup>  
 9—2571 (6)  
 10—2683  
 12—2060  
 14—2685  
 20—2059; 2843<sup>b</sup>  
 23—2496 (5); 2562 (2); 2683 (3);  
 2684 (7)  
 27—2267<sup>b</sup>
- 2 THESS 1**  
 5—986 (2)  
 6—2571 (7)  
 7—2581  
 10—616 (1)  
 11—990<sup>b</sup>
- 2 THESS 2**  
 1—2054 (2)  
 2—957  
 3—154 (2); 1957<sup>b</sup>; 2320<sup>b</sup>  
 4—982<sup>b</sup>  
 6—984<sup>2</sup>; 2969 (1)  
 7—2105<sup>b</sup>  
 9—986; 2694<sup>b</sup>  
 10—3026<sup>b</sup>  
 13—742; 3019 (16)  
 15—3004 (2)
- 2 THESS 3**  
 3—1090<sup>b</sup>  
 6—3004 (2)  
 10—2670 (8)  
 12—2970  
 14—1051; 2267<sup>b</sup>  
 17—967
- 1 TIM 1**  
 4—943 (2); 1085; 1242 (3)  
 8—1851  
 9—1859; 2262  
 12—2261<sup>b</sup>  
 13—2799 (6)  
 15—1090<sup>b</sup>; 1091  
 18—480  
 19—90 (4)  
 20—1051; 2670 (8)

1 TIM 2	2 TIM 3	HE 2— <i>continued</i>
1—1484	1—980	14—492 (5); 2532 (a); 2694 (3)
2—1294 <sup>2</sup>	2—1243	15—2654 (4); 2854 <sup>b</sup>
4—2549 (2); 2559 <sup>b</sup> ; 2562	5—1270	16—2670 (2)
5—616; 2023; 2532; 3014 (6)	6—2261	17—1091; 2439 (2); 2445; 2467;
6—2024; 2654	8—2560 <sup>b</sup>	2536; 2654; 2656 (3)
9—2202; 2820 <sup>b</sup>	12—2327 (21)	HE 3
12—3103 (4)	15—300; 468 <sup>b</sup>	1—2024
13—53 (4)	16—1474 (1); 1482 (17)	2—1091
14—492 (5); 3101 (7)	2 TIM 4	7—1478 <sup>b</sup>
15—607 <sup>b</sup> ; 3100 <sup>b</sup>	1—1804 <sup>b</sup> ; 2250 (4)	9—2943
1 TIM 3	2—2434 (9)	HE 4
2—654 <sup>b</sup> ; 881 (3); 1433 (7);	3—886 (2)	2—398 (3); 2929
2820 <sup>b2</sup>	4—1085	6—3033
4—1293 <sup>b</sup>	8—1173; 2268 <sup>b</sup>	12—2496 <sup>b</sup>
6—2157	11—2985 (19)	13—1467 (2)
9—2105	13—669 <sup>b</sup> ; 1886 (14); 2247 <sup>b</sup>	14—264 (IV); 2043 <sup>b</sup> ; 2446
15—2260 <sup>b</sup> ; 3026	14—91 (6)	15—265 <sup>b</sup> ; 2024; 2415; 2670 (2);
16—264 (5); 982 <sup>b</sup> ; 2105; 2261 <sup>b</sup> ;	16—2325 <sup>b</sup>	2943
2341; 2430; 2636 (1)	17—982 <sup>b</sup>	HE 5
1 TIM 4	20—3023 <sup>b</sup>	1—265 <sup>b</sup> ; 2024; 2439 (1); 2440
2—2710	21—2501; 2710 <sup>b</sup>	(3)
3—197; 520; 1242 (1)	TIT 1	2—2653 (3)
7—1085; 1172	2—1090 <sup>b</sup>	4—2445
10—2562	5—655; 2437 (2)	7—72 (1); 2342 (3); 2432 (2)
14—480	7—881 (3)	8—2025; 2176 (2); 2670 (2)
1 TIM 5	8—1433 (7)	9—333; 2175 <sup>b</sup>
10—1125 <sup>b</sup> ; 1433 (7); 3073	14—1085	12—2052; 2625 (2); 2843 <sup>b</sup>
17—654 <sup>b</sup>	15—2056 (2)	13—1069
18—1483 (18); 2102 <sup>b</sup>	16—2560 <sup>b</sup>	14—2720
19—480 (6)	TIT 2	HE 6
23—3088 (2)	2—881; 2820 <sup>b</sup>	1—266 (7); 398; 742
1 TIM 6	7—1294	2—385 (1); 389; 2200
7—2258 <sup>b</sup>	11—2562; 2669	4—486; 2244; 2329
9—2819 <sup>b</sup>	13—2341	6—319 <sup>b</sup>
10—1182 <sup>b</sup>	TIT 3	8—2560 <sup>b</sup>
12—742	5—394 (4); 395 <sup>a</sup> ; 398 (2); 925	12—1549 <sup>b</sup>
15—2423	(III)	13—2173 (4)
16—692 <sup>b</sup> ; 1891	8—1090 <sup>b</sup>	18—266 (7); 1462
18—2427	10—1051; 1377 <sup>a</sup>	19—326 <sup>b</sup> ; 2777 (3)
20—830; 1240; 1242 (3); 2702 <sup>b</sup>	HE 1	20—264; 333; 1131 <sup>b</sup>
2 TIM 1	1—335 (III); 467 (1); 618;	HE 7
6—480	1047; 2019 (3); 2024	3—230 (12); 2440; 2928 <sup>b</sup>
9—1130	2—692 (4)	4—2445 (2)
10—34 (2); 1461; 2341	3—264; 615 <sup>b</sup> ; 1451 <sup>a</sup> ; 1914 (2);	5—2987 <sup>b</sup>
13—742	2337 <sup>b</sup> ; 2654 (7)	9—2444 (4)
14—830	5—3055 (1)	14—2028 <sup>b</sup>
2 TIM 2	6—1633; 2196	16—943 (1); 2341 <sup>b</sup> ; 2446
3—257	7—1478 <sup>b</sup>	21—2558 <sup>b</sup>
5—1172	8—2341 (1)	22—2872
7—2056 <sup>b</sup>	10—3034 (2)	24—265 (4)
11—742; 2261 <sup>b</sup>	HE 2	25—322 (2); 2025; 2670 (2)
13—1090 <sup>b</sup> ; 1698 (4)	2—324; 1851 (2); 2023	26—1630 <sup>b</sup>
17—91 (5); 1173 <sup>b</sup>	4—2064 (4); 2844	27—2445
18—1444 (3)	5—980	HE 8
19—2112 <sup>b</sup> ; 2485 <sup>b</sup> ; 2709 <sup>b</sup>	9—264 (IV); 2341 <sup>b</sup> ; 2657	1—265 <sup>b</sup>
20—2202 <sup>b</sup> ; 2426 <sup>b</sup>	10—333; 2024	2—2025
		3—2024; 2440

<p>HE 8—<i>continued</i></p>	<p>HE 12—<i>continued</i></p>	<p>JAS 5</p>
<p>6—616<sup>b</sup>; 732 (7); 2549<sup>b</sup>; 2654 7—2653 (3) 8—2517<sup>b</sup></p>	<p>6—1932 (2) 8—413<sup>b</sup> 9—2841 (2)</p>	<p>3—980; 2627<sup>b</sup> 7—2480 (5) 8—616 (1); 2054</p>
<p>HE 9</p>	<p>14—2685 (1)</p>	<p>11—1687 (3); 2402</p>
<p>5—2467 (1) 8—2892 (1) 9—396; 3029 (1)</p>	<p>18—485; 2997 (2) 22—980 23—654; 2563 (5); 2837<sup>b</sup></p>	<p>12—1851 (5) 14—480 (3) 15—2783<sup>b</sup> 17—933; 2256</p>
<p>10—394; 2545<sup>b</sup> 11—731 (4); 980; 1405 (4); 2670 (2)</p>	<p>24—323; 616<sup>b</sup>; 2025 26—833 27—1353 (7)</p>	<p>1 PET 1</p>
<p>12—264; 265<sup>b</sup>; 2531<sup>b</sup>; 2654 (1.6); 2656 (3)</p>	<p>28—468 (2); 991 (IX)</p>	<p>2—323<sup>b</sup>; 620<sup>b</sup>; 1130 (4); 2023; 2683; 2847; 3019<sup>b</sup></p>
<p>14—2176 (3); 2445; 2670 (2) 15—616<sup>b</sup>; 729<sup>b</sup>; 732 (5); 2274</p>	<p>HE 13</p>	<p>3—925 (III); 1460 (III) 5—980; 1840 6—2943</p>
<p>16—2950 22—2025 23—2538 (4); 3029</p>	<p>2—1433 (7) 4—520 9—1360<sup>b</sup></p>	<p>7—2351 (4) 8—2329 9—395</p>
<p>24—322 (2); 326; 396; 1110; 1488 26—2177 27—989<sup>b</sup>; 2503</p>	<p>12—2025 15—546<sup>b</sup> 16—2845 23—2985<sup>b</sup></p>	<p>11—2342 (III); 2457; 2480 (5) 12—1482<sup>b</sup>; 2350 (5) 17—3113<sup>b</sup></p>
<p>28—616 (1); 1464</p>	<p>JAS 1</p>	<p>18—1823; 2024; 2434<sup>b</sup>; 2531<sup>b</sup>; 2541; 2653 (3)</p>
<p>HE 10</p>	<p>1—2022<sup>b</sup> 2—2943<sup>2</sup></p>	<p>19—2654 20—1130 (4) 22—3026</p>
<p>1—31 (<i>d</i>); 266 (7); 326<sup>b</sup>; 980; 1135<sup>b</sup>; 1851; 2653 (3); 3029 (1)</p>	<p>5—2480 (5) 11—3086 (5) 13—1042 14—1094</p>	<p>23—397<sup>b</sup>; 399; 2549; 2550; 2712<sup>b</sup></p>
<p>2—2654 (6) 3—1134 (8) 5—492 (2)</p>	<p>17—302 (6); 303 18—399<sup>2</sup>; 2022<sup>b</sup>; 2548<sup>b</sup>; 2550 (6); 3026</p>	<p>1 PET 2</p>
<p>7—2025 12—615<sup>b</sup> 13—266 (7) 14—1928</p>	<p>21—2837<sup>b</sup>; 2871 25—1851 (5); 1881<sup>b</sup> 27—2427 (4); 2557</p>	<p>2—2052; 2549 4—1795<sup>b</sup> 5—2023; 2445; 2446 (3); 2845 8—1130<sup>b</sup></p>
<p>19—290; 2656 (3); 2892 (1) 22—393; 395; 2684<sup>b</sup> 23—1090<sup>b</sup></p>	<p>JAS 2</p>	<p>9—652 (4); 1404 (4); 2354 (5) 11—1037; 2350 14—2429</p>
<p>26—2244; 2329; 3026 29—1291; 2571 (8); 2682<sup>b</sup>; 3113<sup>b</sup> 32—1449 39—2320<sup>b</sup>; 2837<sup>b</sup></p>	<p>1—1786; 2022<sup>b</sup>; 2342 (III) 2—2594<sup>b</sup>; 3111<sup>b</sup> 3—1126</p>	<p>19—2353 (2) 20—2658 (4) 21—323; 625; 1852 (6); 2023 22—1630<sup>b</sup>; 2656 (4) 24—1464</p>
<p>HE 11</p>	<p>5—991 (IX); 2421; 2480 (5) 8—1851<sup>b</sup>; 2133 10—1310 14—1088; 1785 (4); 2427 (4)</p>	<p>1 PET 3</p>
<p>1—1088 (4) 3—318<sup>b</sup>; 738; 1214; 2640 (1) 4—5 5—3007</p>	<p>19—2291 20—2523 22—1567 23—2517 26—2497 (3)</p>	<p>4—2202 6—2691<sup>b</sup> 12—2325<sup>b</sup>; 2480 (5) 15—2682<sup>b</sup> 16—2670 (3) 17—2657 (2)</p>
<p>6—319<sup>b</sup>; 2430 9—1555 11—1090<sup>b</sup>; 2691<sup>b</sup> 13—975 (2) 21—1552 24—2360</p>	<p>JAS 3</p>	<p>18—323<sup>b</sup>; 2023; 2177; 2342; 2354 (6); 2456<sup>b</sup>; 2653 (3); 2656 (4); 2658 (4) 19—200; 992 (5); 2503 (3); 2563 (5) 21—393; 394; 395; 398 (2); 2548<sup>b</sup> 22—615<sup>b</sup></p>
<p>27—2084 (4) 31—2525 32—2675 (2); 2677 37—170<sup>b</sup>; 1250</p>	<p>2—533 6—2122; 3083 9—146 (3) 14—3026 15—887 (4) 18—2293</p>	<p>1 PET 4</p>
<p>HE 12</p>	<p>JAS 4</p>	<p>3—207 (4); 1448 6—992 (5)<sup>2</sup>; 2457</p>
<p>1—992 (3); 1172 (<i>e</i>) 2—333; 615<sup>b</sup>; 1111<sup>b</sup></p>	<p>3—116<sup>b</sup> 7—2695 11—533; 1851<sup>b</sup></p>	

1 PET 4—*continued*

9—1433 (7)  
10—2843  
11—2199 (3)  
12—2623  
13—2351 (4); 2581  
19—1090<sup>b</sup>

## 1 PET 5

1—1718<sup>b</sup>; 2437 (2)  
4—1173  
5—2353<sup>b</sup>  
9—525 (2)  
13—2350 (5)

## 2 PET 1

1—2342  
2—2357 (1)  
4—692 (3)  
6—881 (3)  
10—1130  
11—991 (IX); 2250 (4)  
13—2356 (6)  
16—1085; 2357; 3005<sup>b</sup>  
19—308; 1474 (2); 2582 (3)  
20—2579; 2580 (6)  
21—1479

## 2 PET 2

1—1377  
2—3026  
4—2457; 2694 (4)  
5—2433 (4)  
10—1003 (7)  
12—1243  
15—379 (4)  
16—1961<sup>b</sup>  
18—99<sup>b</sup>; 101  
20—2357 (1)

## 2 PET 3

1—2350 (5)  
2—185  
3—1668 (7)  
5—2357<sup>b</sup>  
6—1354 (9)  
10—2624 (1)  
12—986; 2054  
13—1353 (5)  
14—2846<sup>b</sup>  
16—460 (2); 3114  
18—2357 (1)

## 1 JN 1

1—1667 (5); 1914<sup>b</sup>  
2—1702<sup>b</sup>; 1705 (2)  
3—1703<sup>b</sup>  
5—1243 (5); 1697 (3); 1891 (3)  
6—2684 (7)  
7—323<sup>b</sup>; 1704<sup>b</sup>; 1929; 2025;  
2654 (6)

1 JN 1—*continued*

8—1698; 1701 (1); 1713 (3);  
2686 (2); 2712<sup>b</sup>  
9—1090<sup>b</sup>  
20—2056 (3)

## 1 JN 2

1—2245<sup>a</sup>; 2246 (7); 2654 (2)  
2—323<sup>b</sup>; 324; 1488; 1702; 2025;  
2467; 2656 (4); 2657  
4—1713 (1); 3025<sup>b</sup>  
5—1263<sup>b</sup>  
9—1698  
13—2342<sup>b</sup>; 2695  
15—1933 (2)  
17—1706; 1717 (4)  
18—983 (3); 1705 (4); 1840  
19—1704<sup>b</sup>  
20—401; 1700<sup>b</sup>; 1701; 1704<sup>b</sup>  
21—1712<sup>b</sup>  
22—155 (3); 1699 (4)  
27—1703 (6); 3026<sup>a</sup>  
28—616

## 1 JN 3

1—1263  
2—609 (3); 1451; 1703<sup>b</sup>; 1706  
4—1701 (1); 1852 (6); 2798 (1)  
5—323<sup>b</sup>; 1630; 2025; 2344  
6—1698 (4)  
7—1243<sup>b</sup>; 1782  
8—1713 (3)  
9—1703 (4); 2684<sup>b</sup>; 2686;  
2712<sup>b</sup>; 2806 (2)  
10—609 (3); 610; 1933<sup>b</sup>; 2549  
16—1698; 1702<sup>b</sup>  
17—2421; 2427 (4)

## 1 JN 4

1—2694<sup>b</sup>; 2843<sup>b</sup>  
2—624 (2); 1700; 2342<sup>b</sup>; 2343  
(2)  
3—155 (3)  
6—1243 (4); 1714  
7—1713<sup>b</sup>; 1933 (1)  
8—51; 1698 (2); 1932  
9—1263; 1698<sup>b</sup>; 1700 (5); 1705  
(2); 2196; 3020<sup>b</sup>  
10—323<sup>b</sup>; 1702; 2025; 2467;  
2656 (4)  
13—1701  
18—2686  
19—1263<sup>b</sup>

## 1 JN 5

1—398; 1704<sup>b</sup>; 2806 (2)  
3—609 (2); 1933 (2)  
4—2695  
5—1700  
6—489<sup>b</sup>; 1663 (f); 1699 (4)  
10—3099<sup>b</sup>  
13—1714 (III); 2549<sup>b</sup>  
16—486

1 JN 5—*continued*

17—1701 (1)  
20—1700<sup>b</sup>; 2342<sup>b</sup>

## 2 JN

6—1933 (2)  
7—155 (3); 2342<sup>b</sup>  
10—1051  
12—736 (13)

## JUDE

1—519  
4—1291 (3); 2023; 2342 (III)  
5—2480 (5)  
6—2694 (4)  
7—990<sup>b</sup>; 2571 (7)  
12—69; 670 (2)  
14—457 (1); 616 (1)  
19—2721  
20—3019<sup>b</sup>  
23—1868; 2846<sup>b</sup>

## REV 1

1—2582 (2)  
3—2582 (2); 2586 (1)  
4—2587; 3019<sup>b</sup>; 3034  
5—323<sup>b</sup>; 1091; 2177; 2653 (6);  
2654; 2684<sup>b</sup>  
6—482 (b)  
7—616  
10—1919 (2); 2633  
12—312  
13—620<sup>b</sup>  
18—2025  
20—308; 553; 2105; 2636 (1)

## REV 2

1—967<sup>b</sup>  
2—983; 2058<sup>b</sup>  
5—553; 2586 (2)  
6—1243<sup>b</sup>  
7—2246 (4); 3009<sup>b</sup>  
8—2587  
9—2427; 2696<sup>b</sup>  
10—2325 (13); 2326 (15)  
13—2892 (1)  
15—983<sup>b</sup>; 2143  
18—2828 (10)  
20—1676 (b); 2977<sup>b</sup>  
24—1243 (b)  
27—2426<sup>b</sup>

## REV 3

4—2112  
7—1795 (b); 2366; 3026  
8—2325 (13)  
9—2696<sup>b</sup>  
14—426<sup>b</sup>; 677 (b); 2025<sup>b</sup>  
17—2427<sup>b</sup>  
20—869  
21—2025

<p style="text-align: center;">REV 4</p> <p>6—604 (7) 7—1074</p> <p style="text-align: center;">REV 5</p> <p>1—376 (2); 2709 (3); 3122<sup>b</sup> 6—620<sup>b</sup>; 2053 9—323; 2025; 2531<sup>b</sup>; 2845 12—2587 17—2171<sup>b</sup></p> <p style="text-align: center;">REV 6</p> <p>9—1315<sup>2</sup>; 2563 10—2571 (7); 3026 11—2564 (4) 13—308 (8) 16—2025<sup>b</sup>; 2571 (6)</p> <p style="text-align: center;">REV 7</p> <p>2—2709<sup>b</sup> 3—172 (b); 1128 4—2455<sup>b</sup> 9—1173; 1315; 2236 (3); 2542 (3); 2593 10—2025 14—2654 (6); 2684<sup>b</sup> 17—510<sup>b</sup></p> <p style="text-align: center;">REV 8</p> <p>10—308<sup>b</sup> 11—3110</p> <p style="text-align: center;">REV 9</p> <p>1—201<sup>b</sup> 4—2455<sup>b</sup>; 2709<sup>b</sup> 11—3; 201<sup>2</sup> 17—522<sup>b</sup></p> <p style="text-align: center;">REV 10</p> <p>4—2709<sup>b</sup></p>	<p style="text-align: center;">REV 11</p> <p>1—982<sup>b</sup>; 2345 8—2821<sup>b</sup>; 2842<sup>b</sup>; 2846 15—991 (IX); 1805; 2250 (4) 18—2571 (6)</p> <p style="text-align: center;">REV 12</p> <p>1—2081<sup>b</sup> 3—155 (4) 6—2003 (b) 7—2583 (1); 2696 (4) 9—492 (5); 2694<sup>b</sup>; 2695 10—2250 (4) 12—976 (5) 13—207</p> <p style="text-align: center;">REV 13</p> <p>1—155 (4) 3—984 (b)<sup>2</sup>; 2586<sup>b</sup> 8—2025<sup>b</sup>; 2519; 2543<sup>b</sup> 14—2586 (3) 16—3124 (3) 18—985; 2138; 2584<sup>b</sup></p> <p style="text-align: center;">REV 14</p> <p>1—3124 (3) 3—2845 4—1003 (7) 10—2571 (6) 11—990<sup>b</sup></p> <p style="text-align: center;">REV 15</p> <p>2—1315; 2091<sup>b</sup> 3—2430; 2845; 3026</p> <p style="text-align: center;">REV 16</p> <p>19—2571 (6)</p> <p style="text-align: center;">REV 17</p> <p>5—358; 2105; 3114<sup>b</sup>; 3124 (3) 7—2636 (1) 8—984 (b)<sup>2</sup>; 2320<sup>b</sup></p>	<p style="text-align: center;">REV 17—continued</p> <p>9—985 11—2586<sup>b</sup> 12—1799 (b) 14—613 (2); 2025 18—2553<sup>b</sup></p> <p style="text-align: center;">REV 18</p> <p>21—2052<sup>b</sup></p> <p style="text-align: center;">REV 19</p> <p>9—3026 10—618; 2044 11—1091 13—1914<sup>b</sup>; 1916 15—2571 (6) 16—2025 20—2694<sup>b</sup></p> <p style="text-align: center;">REV 20</p> <p>1—987 3—2709 (3) 4—2563 5—2565<sup>2</sup> 8—1965<sup>b</sup> 10—990<sup>b</sup>; 2695 12—2502<sup>b</sup> 13—1315 (4)</p> <p style="text-align: center;">REV 21</p> <p>1—2546 (1) 2—1622 8—1887 (2)</p> <p style="text-align: center;">REV 22</p> <p>2—2026; 3009<sup>b</sup>; 3010 7—2586 (1) 8—61; 2583 (2) 11—2502 13—2587 16—308 18—2582 (2)</p>
---	---	--

## INDEX OF HEBREW AND ARAMAIC WORDS

א	אביר	אבשי
אב 2 <sup>b</sup> ; 6 <sup>b</sup> ; 474 <sup>b</sup> ; 1100 <sup>a</sup> ; 2264 <sup>a</sup> ; 2554 <sup>a</sup>	אביר 1423 <sup>b</sup>	אבשילום see אבישיר
אב see אוב	אבירם 12 <sup>b</sup> ; 18 <sup>a</sup> ; 1532 <sup>a</sup>	אבשילום see אבישילום
אבקה 3 <sup>a</sup>	אבירשג 12 <sup>b</sup>	אגא 71 <sup>b</sup>
אבד 834 <sup>a</sup> ; 1086 <sup>a</sup>	אבירשוע 13 <sup>a</sup>	אגג 69 <sup>a</sup>
אבדון 2 <sup>b</sup> ; 201 <sup>b</sup> ; 834 <sup>a</sup>	אבירשור 13 <sup>b</sup>	אגג 69 <sup>a</sup> ; 1957 <sup>a</sup>
אבדן 201 <sup>b</sup>	אבירשי } 13 <sup>a</sup> ; 1623 <sup>a</sup>	אגקה 528 <sup>a</sup> ; 887 <sup>b</sup> ; 3127 <sup>a</sup>
אבה 3085 <sup>a</sup>	אבשילום } 18 <sup>a</sup> ; 23 <sup>b</sup>	אגוז 1123 <sup>a</sup> ; 2170 <sup>b</sup> ; 2218 <sup>b</sup>
אבס 745 <sup>b</sup> ; 2847 <sup>b</sup>	אבשילום } 18 <sup>a</sup> ; 23 <sup>b</sup>	אגור 78 <sup>a</sup>
אבסיה 2030 <sup>a</sup>	אבקה 7 <sup>b</sup>	אגורה 2076 <sup>b</sup>
אבי 6 <sup>b</sup>	אבל 1105 <sup>a</sup>	אגלים 905 <sup>b</sup>
אביאל 9 <sup>a</sup> ; 55 <sup>b</sup>	אבל 5 <sup>b</sup> ; 2407 <sup>a</sup>	אגם 658 <sup>a</sup> ; 2419 <sup>b</sup> ; 2420 <sup>a</sup> ; 2527 <sup>a</sup> ; 2544 <sup>a</sup>
אביאסיה 7 <sup>b</sup>	אבל 3047 <sup>b</sup>	אגמון 541 <sup>a</sup> ; 1419 <sup>a</sup> ; 2527 <sup>a</sup>
אביב 9 <sup>a</sup> ; 541 <sup>b</sup>	אבל ביה } 5 <sup>b</sup>	אגן 1250 <sup>a</sup> ; 1251 <sup>a</sup>
אביגיל } 9 <sup>b</sup>	אבל מכה } 5 <sup>b</sup>	אגה 382 <sup>a</sup>
אביגיל } 9 <sup>b</sup>	אבל השטים 6 <sup>a</sup>	אגטל 595 <sup>a</sup> ; 2408 <sup>a</sup>
אבידן 9 <sup>a</sup> ; 1338 <sup>a</sup>	אבל כרמים 5 <sup>b</sup> ; 2013 <sup>a</sup> ; 2407 <sup>a</sup>	אד 2067 <sup>a</sup> ; 3046 <sup>a</sup>
אבידע 9 <sup>a</sup>	אבל מחולה 6 <sup>a</sup>	אדבאל 54 <sup>b</sup>
אביה } 10 <sup>a</sup>	אבל מים 6 <sup>a</sup>	אדד 1447 <sup>b</sup>
אביה } 10 <sup>a</sup>	אבל מצרים 6 <sup>a</sup>	אדו 1447 <sup>b</sup>
אביהוא 10 <sup>a</sup>	אבן 494 <sup>a</sup> ; 591 <sup>a</sup> ; 722 <sup>a</sup> ; 1893 <sup>b</sup> ; 1984 <sup>b</sup> ; 2007 <sup>a</sup> ; 2758 <sup>b</sup> ; 2856 <sup>a</sup> ; 2999 <sup>a</sup> ; 3079 <sup>a</sup> ; 3155 <sup>a</sup>	אדום see אדם
אביהוד 10 <sup>a</sup>	אבן } 478 <sup>b</sup> ; 2050 <sup>a</sup> ; 2862 <sup>b</sup>	אדון 1264 <sup>b</sup> ; 1266 <sup>a</sup> ; 1919 <sup>a</sup> ; 2007 <sup>b</sup> ; 2389 <sup>b</sup> ; 2908 <sup>a</sup>
אביהול } 10 <sup>a</sup>	אבן } 3082 <sup>b</sup>	אדורים 60 <sup>a</sup>
אביהול } 10 <sup>a</sup>	אבקה 3 <sup>a</sup>	אדיר 1050 <sup>a</sup> ; 1167 <sup>a</sup> ; 1278 <sup>b</sup> ; 2154 <sup>a</sup> ; 2775 <sup>b</sup> ; 3113 <sup>a</sup>
אביון 890 <sup>b</sup> ; 2130 <sup>a</sup> ; 2420 <sup>a, b</sup>	אבנה 3 <sup>a</sup>	אדלףא 48 <sup>b</sup>
אבינה 566 <sup>b</sup>	אבן הקור 591 <sup>a</sup> ; 890 <sup>b</sup>	אדם 2524 <sup>b</sup> ; 2861 <sup>a</sup>
אביהול see אביהול	אבגר } 14 <sup>b</sup> ; 18 <sup>a</sup>	אדם 48 <sup>b</sup> ; 49 <sup>b</sup> ; 54 <sup>a</sup> ; 140 <sup>b</sup> ; 144 <sup>b</sup> ; 145 <sup>a</sup> ; 287 <sup>b</sup> ; 488 <sup>b</sup> ; 819 <sup>b</sup> ; 2015 <sup>a</sup> ; 2337 <sup>a</sup> ; 2404 <sup>a</sup> ; 2835 <sup>b</sup> ; 2861 <sup>a</sup> ; 3109 <sup>b</sup>
אביטוב 13 <sup>b</sup>	אבס 745 <sup>b</sup> ; 2847 <sup>b</sup>	אדם 675 <sup>b</sup> ; 1254 <sup>b</sup> ; 2524 <sup>b</sup>
אביטל 13 <sup>b</sup>	אבעבקה 485 <sup>b</sup> ; 2405 <sup>a</sup>	אדם } 49 <sup>b</sup> ; 89 <sup>a</sup>
אבים 10 <sup>b</sup>	אבץ 890 <sup>b</sup>	אדום } 2856 <sup>b</sup> ; 2857 <sup>a</sup> ; 2861 <sup>a, b</sup>
אבימאל 11 <sup>a</sup>	אבץ 1446 <sup>b</sup>	אדמה 56 <sup>b</sup>
אבימלך 11 <sup>b</sup>	אבקה 2427 <sup>b</sup>	אדמה 49 <sup>b</sup> ; 54 <sup>a</sup> ; 144 <sup>b</sup> ; 667 <sup>a</sup> ; 724 <sup>a</sup> ; 887 <sup>a</sup> ; 1307 <sup>a</sup> ; 1442 <sup>b</sup> ; 1826 <sup>b</sup> ; 2000 <sup>a</sup>
אביקרב 12 <sup>a</sup> ; 434 <sup>b</sup>	אבר 1267 <sup>a</sup> ; 2400 <sup>a</sup>	
אבינעם 12 <sup>b</sup>	אברה 2400 <sup>a</sup>	
אביר see אבגר	אברהם 18 <sup>a</sup>	
אביסה 7 <sup>b</sup>	אברף 22 <sup>b</sup> ; 1739 <sup>b</sup>	
אביעזר 9 <sup>a</sup> ; 1574 <sup>a</sup>	אברם 18 <sup>a</sup>	
אביעלבוך 7 <sup>b</sup>		
אביר 1254 <sup>b</sup> ; 1265 <sup>a</sup> ; 1267 <sup>a</sup> ; 2189 <sup>a</sup>		



אָדמוּנִי	see אָדמוּנִי	אָזבִיל	2177 <sup>b</sup>	אָזוב	1445 <sup>b</sup>
אָדמוּנִי	54 <sup>b</sup> ; 2133 <sup>a</sup>	אָזבִל	2595 <sup>a</sup> ; 2867 <sup>a</sup> ; 3032 <sup>a</sup> ; 3074 <sup>b</sup>	אָזור	877 <sup>b</sup>
אָדמוּנִי	64 <sup>a</sup>	אָזִד	514 <sup>a</sup> ; 1112 <sup>b</sup>	אָזקְרָה	2030 <sup>b</sup>
אָדמוּנִי	} 2524 <sup>b</sup>	אָזָה	733 <sup>b</sup> ; 1548 <sup>a</sup> ; 1941 <sup>b</sup> ; 1942 <sup>a</sup>	אָזל	343 <sup>a</sup> ; 1152 <sup>b</sup> ; 1248 <sup>a</sup>
אָדמוּנִי		אָזִי	3042 <sup>b</sup>	אָזל	1081 <sup>b</sup>
אָדמוּנִי	56 <sup>b</sup>	אָזִל	2045 <sup>a</sup> ; 3042 <sup>b</sup>	אָזָן	65 <sup>a</sup> ; 886 <sup>a</sup>
אָדמוּנִי	2821 <sup>a</sup>	אָזִל	1041 <sup>b</sup>	אָזִן שְׁאָרָה	3043 <sup>a</sup>
אָדמוּנִי	see אָדמוּנִי	אָזִב	see אָזִב	אָזִנֹת תְּבוּר	345 <sup>a</sup>
אָדמוּנִי	54 <sup>b</sup>	אָזִב	see אָזִב	אָזִנִי	2206 <sup>b</sup>
אָדמוּנִי	57 <sup>a</sup> ; 430 <sup>b</sup> ; 598 <sup>a</sup> ; 1252 <sup>a</sup> ; 1254 <sup>b</sup> ; 1264 <sup>b</sup> ; 1266 <sup>a</sup> ; 1780 <sup>a</sup> ; 1919 <sup>a</sup>	אָזִל	1124 <sup>a, b</sup>	אָזִנְיָה	342 <sup>a</sup>
אָדמוּנִי	57 <sup>a</sup>	אָזִל מְרֻדָּה	1043 <sup>a</sup>	אָזִר	2868 <sup>b</sup>
אָדמוּנִי	57 <sup>a</sup>	אָזִל	1265 <sup>b</sup>	אָזִרֹשׁ	246 <sup>b</sup>
אָדמוּנִי	57 <sup>a</sup>	אָזִל	3032 <sup>a</sup>	אָזִרְחָה	417 <sup>a</sup> ; 1418 <sup>a</sup> ; 1826 <sup>b</sup> ; 2467 <sup>b</sup>
אָדמוּנִי	57 <sup>a</sup>	אָזִל	1438 <sup>b</sup> ; 2421 <sup>a</sup> ; 2935 <sup>b</sup> ; 3033 <sup>a</sup>	אָזִרְיָה	1085 <sup>a</sup>
אָדמוּנִי	58 <sup>a</sup>	אָזִל	1124 <sup>b</sup>	אָזִי	6 <sup>b</sup> ; 78 <sup>b</sup> ; 525 <sup>a, b</sup> ; 526 <sup>a</sup> ; 1351 <sup>b</sup> ; 1436 <sup>b</sup> ; 1799 <sup>a</sup> ; 2554 <sup>b</sup>
אָדמוּנִי	58 <sup>a</sup>	אָזִל	2188 <sup>b</sup>	אָזִי	739 <sup>a</sup> ; 868 <sup>b</sup> ; 1548 <sup>a, b</sup> ; 2697 <sup>a</sup> ; 3084 <sup>b</sup>
אָדמוּנִי	58 <sup>a</sup>	אָזִל	1279 <sup>a</sup> ; 2193 <sup>a</sup> ; 2194 <sup>a</sup> ; 2453 <sup>a</sup>	אָזִיב	} 78 <sup>b</sup> ; 80 <sup>a</sup>
אָדמוּנִי	1418 <sup>b</sup> ; 2315 <sup>b</sup>	אָזִל	340 <sup>a</sup> ; 473 <sup>a</sup> ; 1469 <sup>a</sup> ; 2156 <sup>b</sup> ; 2193 <sup>a</sup> ; 3045 <sup>b</sup>	אָזִיבִן	
אָדמוּנִי	54 <sup>b</sup> ; 541 <sup>b</sup> ; 2975 <sup>b</sup>	אָזִל	2196 <sup>a</sup>	אָזִיבִן	1113 <sup>a</sup>
אָדמוּנִי	55 <sup>a</sup>	אָזִל	2194 <sup>a</sup>	אָזִיבִן	1117 <sup>b</sup> ; 2013 <sup>a</sup> ; 2089 <sup>b</sup> ; 2544 <sup>a</sup>
אָדמוּנִי	2975 <sup>b</sup>	אָזִל	3038 <sup>b</sup>	אָזִיבִן	916 <sup>a</sup>
אָדמוּנִי	788 <sup>a</sup> ; 2077 <sup>a</sup>	אָזִל	2197 <sup>a</sup>	אָזִיבִן	87 <sup>a</sup>
אָדמוּנִי	61 <sup>b</sup>	אָזִל	2194 <sup>a</sup>	אָזִיבִן	87 <sup>a</sup>
אָדמוּנִי	900 <sup>b</sup>	אָזִל	3038 <sup>b</sup>	אָזִיבִן	87 <sup>a</sup>
אָדמוּנִי	1235 <sup>b</sup> ; 1984 <sup>a</sup> ; 2814 <sup>a</sup>	אָזִל	2197 <sup>a</sup>	אָזִיבִן	376 <sup>a</sup> ; 1375 <sup>b</sup>
אָדמוּנִי	432 <sup>b</sup> ; 1146 <sup>a</sup> ; 1931 <sup>b</sup> ; 1934 <sup>a</sup>	אָזִל	see אָזִל	אָזִיבִן	2554 <sup>b</sup> ; 2813 <sup>a</sup>
אָדמוּנִי	1934 <sup>a</sup>	אָזִל	254 <sup>b</sup> ; 587 <sup>b</sup> ; 2863 <sup>a</sup> ; 3007 <sup>b</sup> ; 3008 <sup>a</sup>	אָזִיבִן	1335 <sup>a</sup> ; 2422 <sup>b</sup>
אָדמוּנִי	1934 <sup>a</sup>	אָזִל	301 <sup>b</sup> ; 517 <sup>b</sup> ; 829 <sup>b</sup> ; 952 <sup>b</sup> ; 1120 <sup>a</sup> ; 1890 <sup>b</sup> ; 1892 <sup>a</sup>	אָזִיבִן	81 <sup>a</sup>
אָדמוּנִי	1931 <sup>b</sup>	אָזִל	18 <sup>b</sup> ; 589 <sup>a</sup> ; 3039 <sup>a</sup>	אָזִיבִן	87 <sup>b</sup>
אָדמוּנִי	2181 <sup>a</sup>	אָזִל	1375 <sup>a</sup>	אָזִיבִן	82 <sup>b</sup>
אָדמוּנִי	78 <sup>a</sup>	אָזִל	3039 <sup>b</sup>	אָזִיבִן	87 <sup>a</sup>
אָדמוּנִי	81 <sup>a</sup>	אָזִל	3040 <sup>a</sup>	אָזִיבִן	87 <sup>a</sup>
אָדמוּנִי	916 <sup>a</sup>	אָזִל	3039 <sup>b</sup>	אָזִיבִן	83 <sup>b</sup>
אָדמוּנִי	2947 <sup>b</sup>	אָזִל	3039 <sup>b</sup>	אָזִיבִן	86 <sup>a</sup> ; 916 <sup>a</sup>
אָדמוּנִי	701 <sup>a</sup> ; 1417 <sup>b</sup> ; 2181 <sup>a</sup> ; 2887 <sup>b</sup> ; 2888 <sup>b</sup> ; 2947 <sup>b</sup>	אָזִל	1113 <sup>a</sup> ; 3040 <sup>b</sup>	אָזִיבִן	83 <sup>b</sup>
אָדמוּנִי	2181 <sup>a</sup>	אָזִל	see אָזִל	אָזִיבִן	see תִּירָה
אָדמוּנִי	2181 <sup>a</sup>	אָזִל	1985 <sup>b</sup> ; 2063 <sup>a</sup> ; 2393 <sup>a</sup> ; 2789 <sup>a</sup> ; 2994 <sup>a</sup> ; 3070 <sup>b</sup> ; 3104 <sup>b</sup>	אָזִיבִן	83 <sup>b</sup>
אָדמוּנִי	2181 <sup>a</sup>	אָזִל	1395 <sup>b</sup>	אָזִיבִן	83 <sup>b</sup>
אָדמוּנִי	102 <sup>b</sup>	אָזִל	1070 <sup>b</sup>	אָזִיבִן	85 <sup>b</sup>
אָדמוּנִי	1 <sup>a</sup> ; 2 <sup>a</sup>	אָזִל		אָזִיבִן	83 <sup>b</sup>
אָדמוּנִי	3032 <sup>a</sup>	אָזִל		אָזִיבִן	86 <sup>b</sup>
אָדמוּנִי	509 <sup>b</sup> ; 690 <sup>a</sup> ; 862 <sup>a</sup> ; 944 <sup>a</sup> ; 1094 <sup>b</sup> ; 2177 <sup>b</sup> ; 2466 <sup>a</sup> ; 2814 <sup>a</sup> ; 3097 <sup>a</sup>	אָזִל		אָזִיבִן	

אַהֲלֹד 84<sup>b</sup>  
 אַהֲיֹמֹת 85<sup>b</sup>  
 אַהֲיֹמֹקָא 85<sup>a</sup>  
 אַהֲיֹמֶן } 84<sup>b</sup>  
 אַהֲיֹמֶן }  
 אַהֲיֹמֶשֶׁן 84<sup>b</sup>  
 אַהֲיֹנָב 85<sup>b</sup>  
 אַהֲיֹלֵעִם 85<sup>b</sup>; 611<sup>a</sup>  
 אַהֲיֹסְמָא 86<sup>a</sup>  
 אַהֲיֹזֶר 83<sup>b</sup>  
 אַהֲיֹקֶס 84<sup>a</sup>  
 אַהֲיֹרִם 86<sup>a</sup>  
 אַהֲיֹרְמִי 86<sup>a</sup>  
 אַהֲיֹרַע 86<sup>a</sup>  
 אַהֲיֹשֶׁתַר 86<sup>a</sup>  
 אַהֲיֹשֶׁר 86<sup>a</sup>  
 אַהֲיֹתְפֶל 86<sup>a</sup>  
 אַהֲלָב 87<sup>a</sup>  
 אַהֲלִי 87<sup>a</sup>  
 אַהֲלָמָה 2856<sup>b</sup>  
 אַהֲמָתָא 36<sup>b</sup>  
 אַתְסָפִי 80<sup>a</sup>  
 אַתַר 818<sup>a</sup>; 820<sup>a</sup>; 1375<sup>b</sup>;  
 2557<sup>b</sup>  
 אַתַר 376<sup>a</sup>; 1121<sup>b</sup>  
 אַתַר 83<sup>b</sup>; 86<sup>a</sup>; 2865<sup>a</sup>  
 אַתְרוֹן } 2026<sup>b</sup>  
 אַתְרוֹן }  
 אַתְרַה 80<sup>b</sup>; 86<sup>a</sup>  
 אַתְרַחַל 80<sup>b</sup>  
 אַתְרִית 943<sup>a</sup>  
 אַתְשֶׁנְרַפֶן 2697<sup>a</sup>  
 אַתְשֶׁנְרוֹשׁ } 80<sup>b</sup>; 260<sup>a</sup>; 3126<sup>a</sup>  
 אַתְשֶׁרֶשׁ }  
 אַתְשֶׁרַי 1311<sup>a</sup>  
 אַתְשֶׁרְנָן 547<sup>b</sup>; 548<sup>a</sup>; 1423<sup>b</sup>;  
 2093<sup>b</sup>  
 אַטָד 317<sup>a</sup>; 2974<sup>a</sup>  
 אַטִין 1111<sup>a</sup>  
 אַטַר 317<sup>b</sup>  
 אַטַר 1865<sup>a</sup>  
 אַי 1511<sup>a, b</sup>; 1548<sup>a, b</sup>;  
 3084<sup>a, b</sup>; 3099<sup>b</sup>  
 אַיָב } 944<sup>b</sup>  
 אַיָב }  
 אַיָבָה 952<sup>b</sup>  
 אַיַד 540<sup>b</sup>  
 אַיָה 88<sup>a</sup>; 477<sup>b</sup>; 1091<sup>b</sup>;  
 1548<sup>a</sup>; 1814<sup>a</sup>

אַיָב 1679<sup>b</sup>  
 אַיָבָל 1675<sup>b</sup>  
 אַיָד }  
 אַיָדָה } 1438<sup>b</sup>  
 אַיָדָה }  
 אַיָדָבָד 1446<sup>b</sup>  
 אַיָדָה 1824<sup>a</sup>  
 אַיָדָה }  
 אַיָדָה } see אַיָד  
 אַיָדָה }  
 אַיָל 226<sup>a</sup>; 817<sup>a, b</sup>; 1265<sup>b</sup>;  
 1435<sup>b</sup>; 2171<sup>a</sup>;  
 2527<sup>b</sup>  
 אַיָל } 817<sup>a, b</sup>; 2527<sup>b</sup>; 2597<sup>a</sup>;  
 אַיָל } 3066<sup>a</sup>; 3155<sup>b</sup>;  
 אַיָל } 3156<sup>a</sup>  
 אַיָלָה 817<sup>a</sup>  
 אַיָלוֹן }  
 אַיָלוֹן } 939<sup>a</sup>; 2949<sup>a</sup>  
 אַיָלוֹן }  
 אַיָלוֹן } 88<sup>a</sup>  
 אַיָלוֹת } 923<sup>a, b</sup>  
 אַיָלוֹת }  
 אַיָלָם } 2935<sup>b</sup>  
 אַיָלָם }  
 אַיָלָמָה } 933<sup>b</sup>  
 אַיָלָם }  
 אַיָלָמָה } 2247<sup>a</sup>  
 אַיָלָמָה }  
 אַיָלוֹן } see אַיָלוֹן  
 אַיָלוֹן }  
 אַיָלוֹת } 817<sup>a</sup>; 1393<sup>a</sup>; 2488<sup>a</sup>;  
 אַיָלוֹת } 2830<sup>b</sup>  
 אַיָם } see אַיָמִים  
 אַיָם } 2949<sup>b</sup>  
 אַיָם }  
 אַיָמָה } 1102<sup>b</sup>; 1423<sup>a</sup>; 2949<sup>b</sup>  
 אַיָמָה }  
 אַיָמִים 940<sup>b</sup>  
 אַיָן 1467<sup>a</sup>; 1821<sup>a</sup>  
 אַיָעָזַר 1574<sup>a</sup>  
 אַיָקָה } 3080<sup>a</sup>  
 אַיָקָה }  
 אַיָש 145<sup>a</sup>; 593<sup>a</sup>; 819<sup>b</sup>;  
 1095<sup>a</sup>; 1106<sup>a</sup>;  
 1279<sup>a</sup>; 1432<sup>b</sup>;  
 1442<sup>a</sup>; 1508<sup>b</sup>;  
 1541<sup>b</sup>; 1971<sup>b</sup>;  
 2337<sup>a</sup>; 2411<sup>a</sup>;  
 2555<sup>a</sup>; 2835<sup>b</sup>;  
 3072<sup>a</sup>; 3100<sup>a</sup>  
 אַיֶשׁ-בֶּשֶׁת 1508<sup>b</sup>  
 אַיֶשׁהֶרֶד 1508<sup>b</sup>; 1511<sup>a</sup>  
 אַיֶשׁוֹן 209<sup>b</sup>; 1070<sup>a</sup>  
 אַיֶשׁ-טֹב 1511<sup>a</sup>

אַיֶשִׁי see יֶשִׁיָה  
 אַיֶתִי 1543<sup>b</sup>  
 אַיֶתִיָאֵל 1543<sup>a, b</sup>  
 אַיֶתְמָר 1543<sup>a</sup>  
 אַיֶתָן } 1012<sup>b</sup>; 1337<sup>b</sup>  
 אַיֶתָן }  
 אַיֶתָנִים 541<sup>b</sup>; 1012<sup>b</sup>  
 אַיֶד } 588<sup>b</sup>; 1438<sup>b</sup>; 2872<sup>a</sup>  
 אַיֶד }  
 אַיֶזִיב 37<sup>b</sup>  
 אַיֶזֶר 763<sup>b</sup>  
 אַיֶישׁ 36<sup>a</sup>  
 אַיֶל 704<sup>b</sup>; 1145<sup>a</sup>  
 אַיֶל 2013<sup>b</sup>  
 אַיֶל } 1543<sup>b</sup>; 3032<sup>a</sup>  
 אַיֶל }  
 אַיֶלָה 1147<sup>b</sup>  
 אַיֶר 1442<sup>b</sup>  
 אַיֶשָׁה 37<sup>a</sup>  
 אַל 1129<sup>b</sup>; 1250<sup>a</sup>; 1251<sup>a</sup>;  
 1254<sup>a</sup>; 1264<sup>b</sup>;  
 1265<sup>b</sup>; 1267<sup>a</sup>;  
 1278<sup>b</sup>; 1294<sup>a</sup>;  
 1493<sup>b</sup>; 1530<sup>b</sup>;  
 1532<sup>a</sup>; 1549<sup>a</sup>;  
 1553<sup>b</sup>; 1555<sup>b</sup>;  
 1879<sup>a</sup>; 2171<sup>a</sup>;  
 2188<sup>b</sup>; 2189<sup>a</sup>;  
 2389<sup>b</sup>; 2949<sup>a</sup>;  
 3034<sup>a</sup>  
 אַל 1126<sup>b</sup>; 2411<sup>a</sup>  
 אַל } 927<sup>b</sup>; 1264<sup>b</sup>; 1267<sup>a</sup>  
 אַל }  
 אַל } 923<sup>b</sup>  
 אַל } see אַל  
 אַל } 96<sup>b</sup>; 2097<sup>b</sup>  
 אַל } 923<sup>b</sup>  
 אַל } 923<sup>b</sup>  
 אַלָה 56<sup>a</sup>; 767<sup>a</sup>; 1265<sup>b</sup>;  
 2172<sup>b</sup>  
 אַלָה 916<sup>b</sup>; 2171<sup>a</sup>; 2407<sup>a</sup>;  
 2949<sup>a</sup>  
 אַלָה 1265<sup>b</sup>  
 אַלָה 2171<sup>a</sup>; 2949<sup>a</sup>  
 אַלָה 1879<sup>a</sup>; 2475<sup>b</sup>  
 אַלָה } see אַלָה  
 אַלָה } 133<sup>b</sup>; 600<sup>b</sup>; 1129<sup>b</sup>;  
 אַלָה } 1202<sup>b</sup>; 1250<sup>a</sup>;  
 אַלָה } 1251<sup>a</sup>; 1254<sup>a</sup>;  
 אַלָה } 1260<sup>a</sup>; 1264<sup>a, b</sup>;  
 אַלָה } 1265<sup>a, b</sup>; 1268<sup>a</sup>;  
 אַלָה } 1270<sup>b</sup>; 1294<sup>a</sup>;  
 אַלָה } 1438<sup>a</sup>; 1454<sup>a</sup>;  
 אַלָה } 1533<sup>a</sup>; 1779<sup>b</sup>;  
 אַלָה } 2835<sup>b</sup>; 2961<sup>a</sup>

אָלוֹהַּ } 1254 <sup>a</sup> ; 1264 <sup>b</sup> ; 1265 <sup>b</sup> ;	אַלְיָשָׁמַע 937 <sup>b</sup>	אַמְרָה } 1087 <sup>b</sup> ; 1088 <sup>b</sup> ; 3025 <sup>a</sup> ;
אָלוֹהַּ } 1779 <sup>b</sup> ; 2012 <sup>b</sup>	אַלְיָשָׁע 934 <sup>b</sup> ; 1743 <sup>b</sup>	אַמְרָה } 3047 <sup>b</sup>
אַלְהַל 541 <sup>b</sup> ; 939 <sup>b</sup>	אַלְיָשָׁפַט 937 <sup>b</sup>	אַמוֹץ 120 <sup>b</sup> ; 125 <sup>b</sup>
אַלְזוֹן 99 <sup>b</sup> ; 939 <sup>a</sup> ; 2033 <sup>b</sup> ;	אַלְיָתָה see אַלְיָאָתָה	אַמִּי 116 <sup>b</sup>
2082 <sup>a</sup> ; 2171 <sup>a</sup> ;	אַלִּם 474 <sup>b</sup> ; 882 <sup>a</sup>	אַמְיָנוֹן see אַמְנוֹן
2172 <sup>b</sup> ; 2407 <sup>a, b</sup> ;	אַלִּם see אֵילִם	אַמֵּן 290 <sup>a</sup> ; 766 <sup>a</sup> ; 1088 <sup>b</sup> ;
2902 <sup>a</sup> ; 2949 <sup>a</sup> ;	אַלִּם see אֲלִמָּה	2170 <sup>a</sup> ; 2556 <sup>a</sup> ;
3128 <sup>a</sup>	אַלִּם 882 <sup>a</sup> ; 1461 <sup>b</sup>	2871 <sup>b</sup>
אַלְזוֹן 99 <sup>b</sup> ; 2171 <sup>a</sup> ; 2407 <sup>a</sup>	אַלְמִגִּים 96 <sup>b</sup> ; 2097 <sup>b</sup>	אַמֵּן 115 <sup>b</sup> ; 3047 <sup>b</sup>
אַלְזוֹן בְּכוֹרֵת 99 <sup>b</sup>	אַלְמָה } 2752 <sup>a</sup>	אַמֵּן 115 <sup>b</sup> ; 2556 <sup>a</sup>
אַלְהִים 882 <sup>a</sup> ; 1289 <sup>b</sup> ; 1308 <sup>b</sup> ;	אַלִּם } 2752 <sup>a</sup>	אַמְנָה 2398 <sup>b</sup>
2779 <sup>a</sup>	אַלְמוֹרֶד 100 <sup>a</sup>	אַמְנָה 3 <sup>a</sup>
אַלְדָּשׁ 112 <sup>b</sup>	אַלְמוֹרֶד 100 <sup>a</sup>	אַמְנָה see אַמְרָה
אַלְזָבָד 940 <sup>a</sup>	אַלְמִלְכָּה 97 <sup>b</sup>	אַמְנוֹן } 118 <sup>a</sup>
אַלְהָה 1110 <sup>b</sup>	אַלְמִנָּה 3084 <sup>a</sup>	אַמְיָנוֹן } 118 <sup>a</sup>
אַלְהִיָּהוּ 928 <sup>a</sup>	אַלֵּן see אֵלִין	אַמְנֵם 1823 <sup>a</sup> ; 2872 <sup>a</sup>
אַלְיָאָב 928 <sup>b</sup>	אַלְנִי see אֲלֹנִי	אַמִּץ 724 <sup>b</sup>
אַלְיָאֵל 929 <sup>a</sup>	אַלְנַעִם 939 <sup>a</sup>	אַמְצִי 128 <sup>a</sup>
אַלְיָאָתָה } 929 <sup>b</sup>	אַלְנָהוּן 939 <sup>a</sup>	אַמְצִיָּה } 114 <sup>a</sup>
אַלְיָתָה } 929 <sup>b</sup>	אַלְסָר 938 <sup>b</sup>	אַמְצִיָּה } 114 <sup>a</sup>
אַלְיָרָד 929 <sup>b</sup>	אַלְעָד 924 <sup>b</sup>	אַמֵּר 210 <sup>a</sup> ; 340 <sup>b</sup> ; 588 <sup>b</sup> ;
אַלְיָרָע 928 <sup>b</sup>	אַלְעָדָה 924 <sup>b</sup>	591 <sup>a</sup> ; 1484 <sup>a</sup> ;
אַלְיָה 2527 <sup>a</sup> ; 2756 <sup>b</sup> ; 2903 <sup>a</sup>	אַלְעִזִּי 939 <sup>b</sup>	2112 <sup>a</sup> ; 2459 <sup>a</sup> ;
אַלְיָה } 65 <sup>a</sup> ; 930 <sup>b</sup>	אַלְעִזָּר 924 <sup>b</sup>	2972 <sup>b</sup>
אַלְיָהוּ } 930 <sup>a</sup>	אַלְעֵלָא } 944 <sup>b</sup>	אַמֵּר 2459 <sup>a</sup>
אַלְיָהוּא } 930 <sup>a</sup>	אַלְעֵלָה } 944 <sup>b</sup>	אַמֵּר 1822 <sup>b</sup>
אַלְיָהוּעִינִי } 929 <sup>b</sup>	אַלְעִשָׂה 923 <sup>a</sup> ; 939 <sup>b</sup>	אַמֵּר 1458 <sup>b</sup>
אַלְיָהוּעִינִי } 929 <sup>b</sup>	אַלֵּם 583 <sup>b</sup> ; 734 <sup>a</sup> ; 882 <sup>a</sup> ;	אַמְרָה } 2839 <sup>b</sup>
אַלְיָהוּפָא 929 <sup>a</sup>	912 <sup>a</sup> ; 927 <sup>b</sup> ; 1056 <sup>a</sup> ;	אַמְרָה } 1466 <sup>a</sup>
אַלְיָהוּרָה 930 <sup>a</sup>	1799 <sup>a</sup> ; 2793 <sup>a</sup> ;	אַמְרִי 119 <sup>a</sup>
אַלְיָל 1258 <sup>a</sup> ; 1454 <sup>a</sup>	2975 <sup>b</sup>	אַמְרִיָּה } 113 <sup>b</sup>
אַלְיָמְלָךְ 923 <sup>b</sup>	אַלֵּם see אֲלִים	אַמְרִיָּה } 113 <sup>b</sup>
אַלְיָסָס 929 <sup>a</sup>	אַלְשַׁעַל 939 <sup>b</sup>	אַמְרַפֵּל 126 <sup>a</sup>
אַלְיָעִזָּר 929 <sup>b</sup>	אַלְיָצְפָן see אֲלִיָצְפָן	אַמְתָּה 1088 <sup>b</sup> ; 2414 <sup>a</sup> ; 3025 <sup>a</sup> ;
אַלְיָעִינִי 929 <sup>b</sup>	אַלְקָנָה 938 <sup>a</sup>	3047 <sup>b</sup>
אַלְיָעָם 929 <sup>a</sup>	אַלְקָשִׁי 938 <sup>a</sup>	אַמְתִּי 117 <sup>a</sup>
אַלְיָפָז 934 <sup>a</sup>	אַלְתָּהוּלָהּ 939 <sup>b</sup>	אַן see אֲוִן
אַלְיָפָל 923 <sup>b</sup>	אַלְתָּקָא } 939 <sup>b</sup>	אַפָּא } 1424 <sup>a</sup>
אַלְיָפָלָהּ 934 <sup>a</sup>	אַלְתָּקָה } 939 <sup>b</sup>	אַפָּה } 1424 <sup>a</sup>
אַלְיָצִיר 938 <sup>a</sup> ; 1743 <sup>b</sup>	אַלְתָּקָן 939 <sup>b</sup>	אַפָּה 495 <sup>a</sup> ; 1354 <sup>b</sup> ; 2512 <sup>b</sup>
אַלְיָצְפָן } 938 <sup>a</sup>	אַל תִּשְׁחַח 2488 <sup>a</sup> ; 2830 <sup>b</sup>	אַפָּה see אַפָּא
אַלְיָצְפָן } 938 <sup>a</sup>	אַם 663 <sup>b</sup> ; 778 <sup>a</sup> ; 2092 <sup>a</sup> ;	אַנָּה see אֲנָה
אַלְיָקָא 923 <sup>b</sup>	2554 <sup>b</sup>	אַנָּה see אֲנָה
אַלְיָקִים 89 <sup>b</sup> ; 929 <sup>a</sup> ; 1579 <sup>a</sup>	אַמָּה 1335 <sup>a</sup> ; 1967 <sup>b</sup>	אַנָּשׁ 145 <sup>a</sup> ; 953 <sup>a</sup> ; 1106 <sup>a</sup> ;
אַלְיָשָׁבַע 934 <sup>a</sup> ; 937 <sup>b</sup>	אַמָּה see אֲמָה	2083 <sup>a</sup> ; 2337 <sup>a</sup> ;
אַלְיָשָׁה 937 <sup>b</sup>	אַמָּה 117 <sup>a</sup> ; 765 <sup>a</sup> ; 2045 <sup>a</sup> ;	2411 <sup>a</sup> ; 3109 <sup>b</sup>
אַלְיָשָׁרַע 938 <sup>a</sup> ; 1743 <sup>b</sup>	3079 <sup>a</sup>	אַנְתָּה 1307 <sup>a</sup>
אַלְיָשִׁיב 929 <sup>a</sup>	אַמוֹן 118 <sup>b</sup> ; 2153 <sup>b</sup> ; 3091 <sup>b</sup>	אַנְתָּרַת 128 <sup>b</sup>
	אַמוֹן 115 <sup>b</sup> ; 1087 <sup>b</sup>	אַנִּי 2731 <sup>a</sup>
		אַנִּי 2774 <sup>a</sup> ; 2775 <sup>b</sup>

אַיִהָ } 2774 <sup>a</sup>	אַפֵּן see אֵיפֵּן	אַרְגַּ 417 <sup>a</sup> ; 3078 <sup>b</sup>
אוֹרֵיָהָ } 2774 <sup>a</sup>	אַפֶּס 136 <sup>a</sup> ; 943 <sup>a</sup> ; 1438 <sup>b</sup>	אַרְגַּב 1344 <sup>a</sup>
אַוִּיָּעִם 136 <sup>a</sup>	אַפֶּס דְּמִים 956 <sup>a</sup>	אַרְגָּוֶן 2509 <sup>b</sup>
אַנְכִּי 2731 <sup>a</sup>	אַפֶּע 2156 <sup>b</sup>	אַרְעֵז 377 <sup>b</sup> ; 673 <sup>a</sup>
אַנֶס 695 <sup>b</sup>	אַפְעָה 2737 <sup>b</sup> ; 2738 <sup>a</sup> ; 3051 <sup>b</sup>	אַרְעָמֶן 675 <sup>b</sup> ; 709 <sup>a</sup> ; 884 <sup>a</sup> ; 2509 <sup>b</sup>
אַנֶה 3113 <sup>a</sup>	אַפֶּק 2867 <sup>a</sup>	אַרְדִּי 238 <sup>b</sup>
אַנְפָּה 1384 <sup>a</sup>	אַפֶּק } 161 <sup>a</sup>	אַרְדִּוֶן 238 <sup>b</sup>
אַנֶס 1306 <sup>b</sup>	אַפִּיק } 161 <sup>a</sup>	אַרְדִּי 261 <sup>a</sup>
אַנְקָה 1106 <sup>b</sup> ; 1181 <sup>a</sup> ; 1906 <sup>a, b</sup> ; 1907 <sup>a</sup>	אַפְקָה 161 <sup>b</sup>	אַרְדִּי 259 <sup>a</sup>
אַנֶשׁ 145 <sup>a</sup> ; 2783 <sup>a, b</sup>	אַפְרִיוֶן 2208 <sup>a</sup>	אַרְדִּי } 2847 <sup>b</sup>
אַנֶשׁ } 2041 <sup>b</sup>	אַפְרִים 963 <sup>a, b</sup> ; 964 <sup>a</sup>	אַרְדִּי } 1350 <sup>a</sup>
אַנֶשׁ } 2041 <sup>b</sup>	אַפְרִי 161 <sup>a</sup>	אַרְדִּי } 261 <sup>a</sup>
אַנְסָא 261 <sup>b</sup>	אַפְרִסְכִּי } 161 <sup>a</sup>	אַרְדִּי } 1 <sup>a</sup> ; 242 <sup>a</sup> ; 605 <sup>a</sup> ; 1886 <sup>a</sup>
אַסֹן 2066 <sup>b</sup> ; 2423 <sup>a</sup>	אַפְרִסְכִּי } 161 <sup>a</sup>	אַרְדִּי } 225 <sup>b</sup>
אַסִיר 382 <sup>a</sup> ; 2456 <sup>a</sup>	אַפְרַת } 964 <sup>a</sup>	אַרְדִּי } 266 <sup>b</sup>
אַסִירָה } 1103 <sup>b</sup>	אַפְרָתָה } 964 <sup>a</sup>	אַרְדִּי } 221 <sup>b</sup> ; 3076 <sup>a</sup>
אַסִיה } 1103 <sup>b</sup>	אַפְרָתִי 963 <sup>b</sup>	אַרְדִּי } 576 <sup>b</sup> ; 1983 <sup>a</sup> ; 2263 <sup>a</sup> ; 2411 <sup>a</sup> ; 2530 <sup>a</sup> ; 3075 <sup>b</sup>
אַסִים 405 <sup>a</sup> ; 2863 <sup>a</sup>	אַפְרָם 2587 <sup>a</sup>	אַרְתָּה 576 <sup>b</sup> ; 3075 <sup>b</sup>
אַסְנַת 266 <sup>b</sup> ; 2089 <sup>b</sup>	אַפְרָן } 1070 <sup>b</sup>	אַרְתָּה } 848 <sup>b</sup>
אַסָה 1177 <sup>b</sup> ; 1199 <sup>a</sup> ; 1737 <sup>a</sup> ; 2116 <sup>a</sup> ; 2534 <sup>b</sup> ; 2538 <sup>b</sup>	אַפְרָן } 1070 <sup>b</sup>	אַרְיִי } 1895 <sup>a, b</sup> ; 3083 <sup>a</sup>
אַסָה 262 <sup>b</sup>	אַפְרָע 1111 <sup>a, b</sup> ; 3079 <sup>a</sup>	אַרְיָא } 241 <sup>a</sup> ; 1596 <sup>b</sup> ; 1895 <sup>a</sup>
אַסָה see אִסְיָה	אַצִיל 721 <sup>b</sup> ; 2154 <sup>a</sup>	אַרְיָא } 241 <sup>a</sup> ; 1596 <sup>b</sup> ; 1895 <sup>a</sup>
אַסְפָּה 288 <sup>b</sup> ; 316 <sup>b</sup> ; 2863 <sup>a</sup>	אַצִיל 250 <sup>b</sup> ; 606 <sup>b</sup>	אַרְיָא } 241 <sup>a</sup>
אַסְפָּסָה 2056 <sup>b</sup>	אַצִל 2864 <sup>a</sup>	אַרְיָא } 241 <sup>a</sup>
אַסְפָּתָא 286 <sup>b</sup>	אַצִל 1338 <sup>a</sup>	אַרְיָא } 241 <sup>a</sup>
אַסִר 267 <sup>b</sup> ; 474 <sup>b</sup> ; 1340 <sup>b</sup> ; 2200 <sup>b</sup>	אַצִל 344 <sup>b</sup>	אַרְיָא } 241 <sup>a</sup>
אַסִר } 3058 <sup>a</sup>	אַצִלָּהוּ 342 <sup>a</sup> ; 997 <sup>b</sup>	אַרְיָא } 241 <sup>a</sup>
אַסִר } 3058 <sup>a</sup>	אַצִם 2206 <sup>b</sup>	אַרְיָא } 241 <sup>a</sup>
אַסִר-תְּדוּן 971 <sup>a</sup>	אַצְעָה 512 <sup>b</sup> ; 513 <sup>a</sup> ; 589 <sup>a</sup>	אַרְיָא } 241 <sup>a</sup>
אַסְתֵּר 1006 <sup>a</sup>	אַצִר 3008 <sup>a, b</sup>	אַרְיָא } 241 <sup>a</sup>
אַה 135 <sup>b</sup> ; 1085 <sup>b</sup> ; 1126 <sup>b</sup> ; 1918 <sup>a</sup> ; 2155 <sup>b</sup> ; 2156 <sup>a</sup> ; 3113 <sup>a</sup> ; 3126 <sup>a</sup>	אַקְדָה 2859 <sup>b</sup> ; 2860 <sup>a</sup>	אַרְיָא } 241 <sup>a</sup>
אַפֵּד see אִפְרֵד	אַקֹ 592 <sup>b</sup> ; 1249 <sup>a</sup> ; 3155 <sup>b</sup> ; 3156 <sup>a</sup>	אַרְיָא } 241 <sup>a</sup>
אַפֵּד 962 <sup>b</sup>	אַקָא 211 <sup>b</sup>	אַרְיָא } 241 <sup>a</sup>
אַפָּה see אִפְפָּה	אַקָלִי 238 <sup>b</sup> ; 1895 <sup>a</sup>	אַרְיָא } 241 <sup>a</sup>
אַפֹד } 878 <sup>a</sup> ; 962 <sup>a</sup> ; 1455 <sup>b</sup>	אַקָב 115 <sup>b</sup>	אַרְיָא } 241 <sup>a</sup>
אַפֹד } 878 <sup>a</sup> ; 962 <sup>a</sup> ; 1455 <sup>b</sup>	אַקָב 211 <sup>b</sup>	אַרְיָא } 241 <sup>a</sup>
אַפִּים 161 <sup>b</sup>	אַקָב 829 <sup>b</sup> ; 3063 <sup>b</sup>	אַרְיָא } 241 <sup>a</sup>
אַפִּים 207 <sup>b</sup>	אַרְבָּאָל see בֵּית אֲרְבָּאָל	אַרְבָּ 818 <sup>a</sup> ; 2263 <sup>b</sup> ; 2459 <sup>a</sup> ; 3007 <sup>b</sup>
אַפִּיק 523 <sup>b</sup> ; 594 <sup>a</sup> ; 2595 <sup>a</sup> ; 2867 <sup>a</sup> ; 3074 <sup>b</sup>	אַרְבָּה 1907 <sup>b</sup> ; 1908 <sup>a, b</sup> ; 2405 <sup>a</sup>	אַרְבָּ 1126 <sup>b</sup> ; 1918 <sup>a</sup> ; 2263 <sup>b</sup>
אַפִּיר see אִפְרִיר	אַרְבָּה 315 <sup>b</sup> ; 1437 <sup>a</sup>	אַרְבָּ 969 <sup>a</sup> ; 2818 <sup>a</sup>
אַפֶל 2177 <sup>b</sup>	אַרְבֹּת 261 <sup>a</sup>	אַרְבָּה 1814 <sup>a</sup>
אַפֶלָּ 962 <sup>a</sup>	אַרְבִּי 226 <sup>a</sup>	אַרְבָּה see אִרְבָּה
	אַרְבַּע } 225 <sup>b</sup> ; 1142 <sup>a</sup>	אַרְבָּי 233 <sup>b</sup>
	אַרְבָּה } 225 <sup>b</sup> ; 1142 <sup>a</sup>	אַרְבִּי 238 <sup>b</sup>
	אַרְבַּעִים 1141 <sup>a</sup>	אַרְבָּם 222 <sup>a</sup> ; 2206 <sup>b</sup> ; 2885 <sup>b</sup>
	אַרְגַּ 940 <sup>a</sup> ; 1545 <sup>b</sup> ; 3077 <sup>a</sup>	אַרְמוֹן 1438 <sup>a</sup> ; 2208 <sup>a</sup>

אַרְמִי 222<sup>a</sup>; 224<sup>b</sup>  
 אַרְמִיָּה 251<sup>a</sup>  
 אַרְן 224<sup>b</sup>  
 אַרְן 224<sup>b</sup>; 266<sup>b</sup>; 2201<sup>a</sup>  
 אַרְן see אַרְוֹן  
 אַרְנַבְתָּ 1338<sup>b</sup>; 1339<sup>a</sup>  
 אַרְנַוִּן } 259<sup>a</sup>  
 אַרְנַוִּן }  
 אַרְנַוִּיָּה see אַרְנַוִּיָּה  
 אַרְנַוִּן 258<sup>b</sup>  
 אַרְנַוִּן 225<sup>b</sup>  
 אַרְפַּד 259<sup>b</sup>  
 אַרְפַּכְשַׁד 2717<sup>b</sup>  
 אַרְץ 315<sup>a</sup>; 316<sup>a</sup>; 586<sup>a</sup>;  
 724<sup>a</sup>; 887<sup>a</sup>; 1281<sup>a</sup>;  
 1307<sup>a</sup>; 1789<sup>a</sup>;  
 1826<sup>b</sup>; 2780<sup>a</sup>;  
 3075<sup>b</sup>; 3106<sup>a</sup>;  
 3108<sup>b</sup>  
 אַרְצָא 261<sup>b</sup>  
 אַרְר 3041<sup>b</sup>  
 אַרְרַט } 224<sup>b</sup>; 247<sup>a</sup>  
 אַרְרַט }  
 אַרְשׁ 454<sup>b</sup>; 997<sup>b</sup>  
 אַשׁ 1112<sup>a</sup>; 2864<sup>b</sup>  
 אַשְׁבַּל 267<sup>b</sup>  
 אַשְׁבֵּן 997<sup>a</sup>  
 אַשְׁבַּע 267<sup>b</sup>  
 אַשְׁבַּעַל 1508<sup>b</sup>  
 אַשְׁד 2867<sup>a</sup>  
 אַשְׁדָּה 2122<sup>b</sup>; 2762<sup>b</sup>; 2867<sup>a</sup>  
 אַשְׁדּוּד 267<sup>b</sup>  
 אַשְׁדּוֹת } 268<sup>a</sup>; 2400<sup>a, b</sup>  
 תַּפְסָּגָה }  
 אַשְׁה 1112<sup>a</sup>  
 אַשְׁה 2639<sup>a, b</sup>; 2643<sup>b</sup>  
 אַשְׁה 145<sup>a</sup>; 526<sup>a</sup>; 1040<sup>a</sup>;  
 1095<sup>a</sup>; 1106<sup>b</sup>;  
 1339<sup>b</sup>; 1426<sup>a</sup>;  
 2555<sup>a</sup>; 3100<sup>a</sup>  
 אַשְׁוּר } 272<sup>a</sup>; 290<sup>b</sup>; 1273<sup>a</sup>;  
 אַשְׁר } 1569<sup>b</sup>  
 אַשְׁוּרִי } 269<sup>b</sup>; 272<sup>a</sup>  
 אַשְׁוּרִי }  
 אַשְׁוּר 269<sup>b</sup>; 1311<sup>a</sup>  
 אַשְׁימָא 269<sup>b</sup>  
 אַשְׁיָרָה see אַשְׁרָה  
 אַשְׁיָשָׁה 1117<sup>b</sup>; 1426<sup>a</sup>; 2527<sup>a</sup>  
 אַשְׁכּוּל } 671<sup>a</sup>; 997<sup>a</sup>; 3050<sup>a</sup>  
 אַשְׁכּוּל }

אַשְׁכְּז 269<sup>b</sup>  
 אַשְׁכַּר 1228<sup>b</sup>  
 אַשְׁל 1307<sup>b</sup>; 2908<sup>a</sup>  
 אַשְׁש } 1102<sup>a</sup>; 1309<sup>b</sup>; 2170<sup>b</sup>  
 אַשְׁש }  
 אַשְׁש 745<sup>b</sup>; 1102<sup>a</sup>; 2020<sup>a</sup>;  
 2639<sup>a</sup>; 3010<sup>a</sup>  
 אַשְׁמָה 2179<sup>b</sup>  
 אַשְׁמוּרָה } 2083<sup>a</sup>; 2145<sup>a</sup>; 2982<sup>a</sup>;  
 אַשְׁמָרָה } 3074<sup>a</sup>  
 אַשְׁמָרַת }  
 אַשְׁנַב 2412<sup>a</sup>  
 אַשְׁנָה 270<sup>a</sup>  
 אַשְׁעַן 997<sup>a</sup>  
 אַשְׁש 862<sup>b</sup>; 3097<sup>b</sup>  
 אַשְׁפָּה 882<sup>b</sup>; 2515<sup>b</sup>  
 אַשְׁפַּז 270<sup>a</sup>  
 אַשְׁפַּר 1118<sup>b</sup>  
 אַשְׁקְלוֹן 269<sup>b</sup>  
 אַשְׁר } 268<sup>a, b</sup>; 1248<sup>a</sup>; 1308<sup>b</sup>  
 אַשְׁר }  
 אַשְׁר 409<sup>a</sup>; 1438<sup>b</sup>; 1439<sup>a</sup>  
 אַשְׁר see אַשְׁוּר  
 אַשְׁרָא 263<sup>a</sup>  
 אַשְׁרָאֵל 267<sup>a</sup>  
 אַשְׁרָה } 108<sup>b</sup>; 268<sup>b</sup>; 1307<sup>b</sup>;  
 אַשְׁרָה } 1386<sup>a</sup>; 1390<sup>b</sup>;  
 1452<sup>a</sup>; 1454<sup>b</sup>;  
 אַשְׁרָה } 1533<sup>b</sup>; 2212<sup>a</sup>;  
 2227<sup>a</sup>; 2234<sup>a</sup>;  
 2527<sup>b</sup>  
 אַשְׁרוּ 269<sup>a, b</sup>  
 אַשְׁרָאֵל 287<sup>a</sup>  
 אַשְׁתָּאֵל } 997<sup>a</sup>  
 אַשְׁתָּאֵל }  
 אַשְׁתָּדּוּר 2712<sup>a</sup>  
 אַשְׁתּוֹן 997<sup>b</sup>  
 אַשְׁתַּמַּע } 997<sup>a</sup>  
 אַשְׁתַּמוּעַ }  
 אַשְׁתַּמוּהָ }  
 אַת 1438<sup>b</sup>; 2725<sup>b</sup>; 2911<sup>a</sup>  
 אַתָּא see אַתָּה  
 אַתְבַּעַל 1012<sup>b</sup>  
 אַתָּה } 287<sup>a</sup>  
 אַתָּה }  
 אַתּוֹן 287<sup>a</sup>; 678<sup>b</sup>  
 אַתּוֹן 1149<sup>b</sup>  
 אַתּוּק } 1167<sup>a</sup>  
 אַתּוּק }

אַתִּי } 1543<sup>b</sup>  
 אַתִּי }  
 אַתָּם 1012<sup>b</sup>  
 אַתְמוּל } 1375<sup>b</sup>  
 אַתְמוּל }  
 אַתְמוּל }  
 אַתְנִי 1036<sup>b</sup>  
 אַתְנִן 1036<sup>b</sup>; 1395<sup>a</sup>  
 אַתְרִים 318<sup>b</sup>  
 ג  
 גָּאָר 424<sup>a</sup>; 658<sup>a</sup>; 2401<sup>b</sup>;  
 3081<sup>a</sup>  
 גָּאָר 658<sup>a</sup>  
 גָּאָרָא 424<sup>a</sup>  
 גָּאָר אֵלִים 424<sup>a</sup>  
 גָּאָרָה 424<sup>a</sup>  
 גָּאָרוֹת 424<sup>a</sup>  
 גָּאָרִי 424<sup>a</sup>  
 גָּאָר לְחֵי רָאִי 424<sup>a</sup>; 1316<sup>b</sup>; 1821<sup>b</sup>  
 גָּאָר שְׁבַע 424<sup>b</sup>  
 גָּאָרַת בְּנֵי־נַעֲמָן } 424<sup>b</sup>  
 גָּאָרַת בְּנֵי־נַעֲמָן }  
 גָּאָרַת בְּנֵי־נַעֲמָן }  
 גָּאָשׁ 6<sup>b</sup>; 672<sup>b</sup>  
 גָּאָשָׁה 672<sup>b</sup>; 1293<sup>a</sup>; 2155<sup>a</sup>  
 גָּאָשִׁים 1293<sup>a</sup>; 3050<sup>a</sup>  
 גָּהָה 210<sup>a</sup>; 1070<sup>a</sup>  
 גָּהִי 421<sup>a</sup>  
 גָּהַל 349<sup>a</sup>; 350<sup>a</sup>; 1590<sup>b</sup>;  
 2765<sup>b</sup>; 2771<sup>b</sup>;  
 2995<sup>a, b</sup>  
 גָּהַל 2179<sup>b</sup>  
 גָּהַל 670<sup>a</sup>; 935<sup>a</sup>; 1839<sup>a</sup>;  
 2524<sup>b</sup>  
 גָּהַל 473<sup>a</sup>  
 גָּהַל 473<sup>a</sup>  
 גָּהַל } 473<sup>a</sup>  
 גָּהַל }  
 גָּהַל 160<sup>b</sup>; 402<sup>a</sup>; 513<sup>b</sup>;  
 518<sup>a</sup>; 1894<sup>a</sup>;  
 2850<sup>a</sup>  
 גָּהַל 1105<sup>a</sup>  
 גָּהַל 423<sup>a</sup>  
 גָּהַל 423<sup>a</sup>  
 גָּהַל 99<sup>b</sup>; 2985<sup>b</sup>; 2999<sup>a</sup>  
 גָּהַל 316<sup>b</sup>; 2221<sup>b</sup>; 2744<sup>b</sup>  
 גָּהַל 417<sup>a</sup>; 2859<sup>a</sup>  
 גָּהַל 423<sup>a</sup>  
 גָּהַל 514<sup>b</sup>

בְּדָקָר	472 <sup>b</sup> ; 474 <sup>b</sup>	בֵּין	766 <sup>a</sup> ; 851 <sup>a</sup> ; 939 <sup>b</sup> ; 1105 <sup>a</sup> ; 1484 <sup>a</sup> ; 1964 <sup>b</sup> ; 1985 <sup>b</sup> ; 2199 <sup>a</sup> ; 2486 <sup>b</sup> ; 2813 <sup>b</sup> ; 2921 <sup>a</sup> ; 3089 <sup>a</sup>	בֵּית-צִוּר	454 <sup>a</sup>
בְּהִי	2309 <sup>a</sup>	בֵּין	518 <sup>b</sup> ; 2018 <sup>b</sup>	בֵּית-רְחֹב	451 <sup>b</sup>
בְּהַט	676 <sup>a</sup> ; 1984 <sup>b</sup> ; 2422 <sup>a</sup>	בִּינָה	2191 <sup>a</sup> ; 3089 <sup>a</sup>	בֵּית רֶפֶא	451 <sup>a</sup>
בְּהַל	3049 <sup>a</sup>	בִּינָה	905 <sup>b</sup>	בֵּית שְׁאֵן	452 <sup>b</sup>
בְּהַמָּה	418 <sup>b</sup> ; 583 <sup>b</sup>	בִּירָה	1137 <sup>a</sup> ; 2208 <sup>a</sup>	בֵּית שֶׁן	
בְּהַמּוֹת	427 <sup>a</sup>	בֵּית	416 <sup>b</sup> ; 442 <sup>a</sup> ; 1094 <sup>b</sup> ; 1185 <sup>b</sup> ; 1417 <sup>b</sup> ; 1418 <sup>a</sup> ; 1434 <sup>b</sup> ; 2554 <sup>a</sup> ; 2930 <sup>a</sup>	בֵּית שְׁמֶשׁ	452 <sup>b</sup>
בְּהֵן	494 <sup>a</sup>	בֵּית אֶן	443 <sup>a</sup>	בֵּית-תַּפְרִיחַ	452 <sup>b</sup>
בְּהַק	1145 <sup>a</sup> ; 1867 <sup>b</sup> ; 2950 <sup>a</sup>	בֵּית אֶל	442 <sup>a</sup> ; 443 <sup>b</sup> ; 444 <sup>b</sup>	בְּקָא	375 <sup>b</sup> ; 2093 <sup>b</sup>
בְּהַרְת	1145 <sup>a</sup> ; 1867 <sup>a</sup>	בֵּית אַרְבַּאֵל	443 <sup>a</sup>	בְּכוֹר	1113 <sup>b</sup> ; 2405 <sup>b</sup> ; 2452 <sup>b</sup> ; 2453 <sup>a</sup>
בְּוֹא	328 <sup>a</sup> ; 728 <sup>b</sup> ; 1107 <sup>b</sup> ; 1221 <sup>a</sup> ; 1248 <sup>a</sup> ; 1273 <sup>a</sup> ; 3075 <sup>b</sup> ; 3082 <sup>a</sup>	בֵּית בְּרָאִי	443 <sup>b</sup>	בְּכִיר	1103 <sup>b</sup> ; 1114 <sup>a, b</sup> ; 1343 <sup>a</sup> ; 2644 <sup>a</sup> ; 2905 <sup>b</sup>
בְּבִב	see בְּבָה , נָבַב	בֵּית בְּרָה	443 <sup>a</sup>	בְּכוּרָה	478 <sup>a</sup> ; 2452 <sup>b</sup>
בְּבִז	535 <sup>b</sup>	בֵּית גְּדָר	445 <sup>b</sup>	בְּלָרָה	
בְּבִזִי	535 <sup>b</sup>	בֵּית גְּמִיל	445 <sup>b</sup>	בְּבוּרָה	1109 <sup>b</sup> ; 1122 <sup>b</sup>
בְּבִי	416 <sup>b</sup>	בֵּית דְּבָלְתוּס	443 <sup>b</sup>	בְּבוּרַת	421 <sup>b</sup>
בְּבִל	528 <sup>a</sup> ; 541 <sup>b</sup>	בֵּית דְּהַגֹּן	443 <sup>b</sup>	בְּכִים	491 <sup>b</sup>
בְּבִס	see בְּמָה	בֵּית הָאָזֶל	445 <sup>b</sup>	בְּכַר	2452 <sup>b</sup>
בְּבִינָה	528 <sup>a</sup>	בֵּית הַגְּלָגֶל	445 <sup>b</sup>	בְּכָר	421 <sup>a</sup> ; 547 <sup>b</sup> ; 548 <sup>a</sup>
בְּבִינִי	see בְּנִי	בֵּית הַיְשִׁימוֹת	449 <sup>a</sup>	בְּכָרָה	547 <sup>b</sup> ; 548 <sup>a</sup>
בְּבִיץ	709 <sup>a</sup> ; 1111 <sup>a</sup> ; 1894 <sup>a</sup> ; 2790 <sup>b</sup> ; 2791 <sup>a</sup>	בֵּית הַיְקָרָס	445 <sup>b</sup>	בְּכָרָה	see בְּכוּרָה
בְּבִיצָץ	512 <sup>b</sup>	בֵּית הַלְקָמִי	450 <sup>b</sup>	בְּכָרוֹ	491 <sup>b</sup>
בְּבִקָּה	171 <sup>b</sup>	בֵּית הַמְּרָקָה	450 <sup>b</sup> ; 1098 <sup>a</sup>	בְּכָרִי	440 <sup>a</sup> ; 472 <sup>b</sup>
בְּבִר	658 <sup>a</sup> ; 2401 <sup>b</sup> ; 2506 <sup>b</sup> ; 2820 <sup>b</sup> ; 3081 <sup>a</sup>	בֵּית הַמְּרָקְבוֹת	450 <sup>b</sup>	בְּל	2411 <sup>a</sup>
בְּבוֹשׁ	700 <sup>b</sup> ; 820 <sup>a</sup> ; 2748 <sup>a</sup> ; 2835 <sup>a</sup>	בֵּית מְרָקְבוֹת	444 <sup>b</sup>	בְּל	427 <sup>a</sup>
בְּבִז	503 <sup>b</sup> ; 2439 <sup>a</sup>	בֵּית הָעֵמֶק	443 <sup>a</sup>	בְּלָאָדָן	379 <sup>b</sup>
בְּבִזָּה	578 <sup>b</sup> ; 2703 <sup>a</sup>	בֵּית הָהָרִים	443 <sup>a</sup> ; 446 <sup>a</sup>	בְּלָגָה	473 <sup>b</sup>
בְּבִזְיוֹתָהָ	485 <sup>a</sup>	בֵּית הָרֶן	446 <sup>a</sup>	בְּלָגִי	473 <sup>b</sup>
בְּבִזָּק	459 <sup>b</sup>	בֵּית הַשְּׁטָה	452 <sup>b</sup>	בְּלָד	473 <sup>b</sup>
בְּבַחֲרִי	3127 <sup>b</sup>	בֵּית-הַשְּׁמַשִּׁי	452 <sup>b</sup>	בְּלָה	379 <sup>b</sup> ; 704 <sup>b</sup>
בְּבַחֲרִי		see בְּחָרִים	בֵּית הַגְּלָה	446 <sup>a</sup>	בְּלָהָה
בְּבַחֲרִים	see בְּחָרִים	בֵּית הַחֹרֹן	446 <sup>a</sup>	בְּלָהָה	2949 <sup>b</sup>
בְּבַחֲרִים	1050 <sup>a</sup> ; 2469 <sup>b</sup>	בֵּית כַּר	443 <sup>b</sup>	בְּלָהָן	474 <sup>a</sup>
בְּבַחֲרִי	27 <sup>b</sup> ; 210 <sup>a</sup> ; 612 <sup>b</sup> ; 925 <sup>a, b</sup> ; 1050 <sup>b</sup> ; 3074 <sup>a</sup> ; 3127 <sup>b</sup>	בֵּית לָהֶם	449 <sup>a</sup>	בְּלוֹ	2919 <sup>b</sup>
בְּבַחֲרִי	see בְּחָרִי	בֵּית לְעַפְרָה	449 <sup>a</sup>	בְּלוֹא	769 <sup>a, b</sup>
בְּבַחֲרִים	378 <sup>a</sup> ; 440 <sup>a</sup>	בֵּית נְמָרָה	450 <sup>b</sup> ; 1866 <sup>b</sup>	בְּלוֹי	
בְּבַחֲרִים		290 <sup>a</sup> ; 578 <sup>b</sup> ; 700 <sup>a</sup> ; 2711 <sup>b</sup>	בֵּית עֲנוֹת	442 <sup>a</sup>	בְּלִטְשָׁאצֵּר
בְּבַחֲרִים	578 <sup>b</sup>	בֵּית עֲנָת	442 <sup>a</sup>	בְּלוֹ	411 <sup>a</sup>
בְּבַחֲרִים	2559 <sup>b</sup>	בֵּית עֲקָד	2752 <sup>b</sup>	בְּלוֹ	875 <sup>b</sup> ; 2469 <sup>b</sup>
בְּבַחֲרִים	432 <sup>b</sup> ; 441 <sup>b</sup> ; 492 <sup>a</sup> ; 2837 <sup>a</sup>	בֵּית עֲקָד	450 <sup>b</sup>	בְּלוֹעַל	431 <sup>a</sup> ; 3037 <sup>b</sup>
בְּבַחֲרִים	1123 <sup>a</sup> ; 2170 <sup>b</sup>	בֵּית עֲקָר	451 <sup>a</sup>	בְּלוֹעַל	349 <sup>a</sup> ; 357 <sup>b</sup> ; 486 <sup>b</sup> ; 700 <sup>b</sup> ; 1086 <sup>a</sup> ; 2469 <sup>b</sup> ; 2819 <sup>a</sup> ; 2929 <sup>a</sup> ; 2995 <sup>a, b</sup>
בְּבַחֲרִים	454 <sup>b</sup>	בֵּית עֲפָר	451 <sup>a</sup>	בְּלוֹעַל	2877 <sup>a</sup>
		בֵּית עֲפָצִי	450 <sup>b</sup>	בְּלוֹעַל	120 <sup>a</sup>
				בְּלוֹעַל	431 <sup>a</sup>
				בְּלוֹעַל	431 <sup>a</sup>
				בְּלוֹעַל	378 <sup>b</sup> ; 473 <sup>b</sup>

בָּלַק 379 <sup>b</sup>	בְּעוֹר 439 <sup>a</sup>	בָּצַע 733 <sup>b</sup> ; 1153 <sup>b</sup>
בְּלִשְׁאֲצֹר } 381 <sup>b</sup> ; 433 <sup>a</sup>	בְּעוֹ 491 <sup>a</sup> ; 1547 <sup>a</sup>	בָּצַע 1153 <sup>b</sup> ; 1935 <sup>a</sup>
בְּלִשְׁאֲצֹר }	בְּעוֹר 418 <sup>b</sup>	בָּצַק 2875 <sup>b</sup>
בְּלִשְׁן 474 <sup>b</sup>	בְּעַל 458 <sup>b</sup> ; 1997 <sup>a</sup>	בָּצַקְתָּ 512 <sup>b</sup>
בְּמֵה 1390 <sup>a, b</sup> ; 1517 <sup>a</sup> ; 1533 <sup>b</sup> ; 1539 <sup>a</sup> ; 1589 <sup>a</sup>	בְּעַל 171 <sup>b</sup> ; 288 <sup>b</sup> ; 345 <sup>a</sup> ; 346 <sup>b</sup> ; 347 <sup>b</sup> ; 348 <sup>b</sup> ; 569 <sup>a</sup> ; 741 <sup>a</sup> ; 883 <sup>b</sup> ; 1254 <sup>b</sup> ; 1427 <sup>a, b</sup> ; 1428 <sup>a</sup> ; 1533 <sup>a</sup> ; 1535 <sup>b</sup> ; 1595 <sup>a, b</sup> ; 1689 <sup>a</sup> ; 1997 <sup>a</sup> ; 2007 <sup>b</sup> ; 2337 <sup>a</sup> ; 2389 <sup>b</sup> ; 2555 <sup>a</sup>	בָּצַר 1106 <sup>b</sup>
בְּמֵה 381 <sup>b</sup>		בָּצַר 459 <sup>b</sup> ; 1274 <sup>a</sup>
בְּמֵהֶל 474 <sup>b</sup>		בָּצַרְהָ 2219 <sup>b</sup>
בְּמֹות 3049 <sup>b</sup>		בָּצַרְהָ 512 <sup>b</sup> ; 2219 <sup>b</sup>
בְּמֹות בְּעַל 381 <sup>b</sup>		בְּבִקַּק 378 <sup>a</sup> ; 509 <sup>b</sup> ; 764 <sup>a</sup> ; 2425 <sup>b</sup> ; 2814 <sup>a</sup>
בֵּן 71 <sup>a</sup> ; 383 <sup>a</sup> ; 401 <sup>b</sup> ; 433 <sup>b</sup> ; 474 <sup>b</sup> ; 528 <sup>b</sup> ; 606 <sup>b</sup> ; 678 <sup>a</sup> ; 2554 <sup>b</sup> ; 2759 <sup>b</sup> ; 2826 <sup>a</sup>	בְּעַל 593 <sup>b</sup>	בְּבִקְתָּהּ 378 <sup>a</sup>
בֵּן 434 <sup>a</sup>	בְּעַל בְּרִית 346 <sup>a</sup> ; 347 <sup>a</sup>	בְּבִקִּי 528 <sup>a</sup>
בֶּן-אָדָם 145 <sup>a</sup>	בְּעַל גֹּד 346 <sup>a</sup> ; 347 <sup>a</sup>	בְּבִקְיָה 528 <sup>a</sup>
בֶּן-אֲבִינֶדָב 434 <sup>a</sup>	בְּעֵלָה 347 <sup>a</sup> ; 2067 <sup>a</sup>	בְּבִקַּע 316 <sup>b</sup> ; 517 <sup>b</sup> ; 668 <sup>b</sup> ; 3045 <sup>a</sup>
בֶּן-אֲוִי 439 <sup>a</sup>	בְּעַל הַמּוֹן 346 <sup>b</sup>	בְּבִקַּע 427 <sup>a</sup> ; 873 <sup>a</sup> ; 2032 <sup>b</sup> ; 3081 <sup>a</sup>
בֶּן-נֶבֶר 435 <sup>b</sup>	בְּעַל זָבוּב 346 <sup>b</sup> ; 348 <sup>a</sup> ; 1120 <sup>b</sup>	בְּבִקְעָא 316 <sup>b</sup>
בֶּן-נֶקֶר 434 <sup>a</sup>	בְּעַל הַנֶּן 347 <sup>a</sup>	בְּבִקְעָה 592 <sup>b</sup> ; 593 <sup>a</sup> ; 673 <sup>a</sup> ; 734 <sup>a</sup> ; 2406 <sup>b</sup> ; 2407 <sup>a</sup> ; 3045 <sup>a</sup>
בְּנָה 145 <sup>b</sup> ; 527 <sup>a, b</sup> ; 1968 <sup>a</sup> ; 2894 <sup>b</sup>	בְּעַל תְּרֵמוֹן 346 <sup>b</sup> ; 347 <sup>b</sup>	בְּבִקַּק 941 <sup>b</sup>
בֶּן-הַדָּר 435 <sup>b</sup>	בְּעֵלִי 347 <sup>b</sup>	בְּבִקֵּר 1472 <sup>b</sup> ; 1799 <sup>a</sup> ; 2710 <sup>a</sup>
בְּנִי 474 <sup>b</sup>	בְּעֵלְרָדַע 423 <sup>b</sup>	בְּבִקֵּר 583 <sup>b</sup> ; 584 <sup>a</sup>
בֶּן-זֹחַת 439 <sup>a</sup>	בְּעֵלְרָה 417 <sup>a</sup>	בְּבִקֵּר 798 <sup>b</sup> ; 1375 <sup>b</sup> ; 2082 <sup>b</sup> ; 2083 <sup>a</sup>
בֶּן-חֹר 438 <sup>a</sup>	בְּעֵלִים 347 <sup>b</sup>	בְּבִקְתָּ 2704 <sup>a</sup>
בֶּן-חֹל 438 <sup>a</sup>	בְּעַל מְעוֹן 347 <sup>b</sup>	בְּבִקְשׁ 1472 <sup>b</sup>
בֶּן-חֶנֶן 438 <sup>a</sup>	בְּעַל מְעוֹר 346 <sup>b</sup>	בְּר 667 <sup>a</sup> ; 668 <sup>b</sup> ; 2041 <sup>b</sup>
בֶּן-חֶסֶד 438 <sup>a</sup>	בְּעַל מְרָצִים 347 <sup>b</sup>	בְּר 433 <sup>b</sup>
בְּנִי 382 <sup>b</sup> ; 383 <sup>a</sup>	בְּעַל צַפּוֹן 348 <sup>a</sup>	בְּר } 3082 <sup>b</sup>
בְּנִי } 528 <sup>b</sup> ; 2835 <sup>a</sup>	בְּעַל שְׁלֹשָׁה 347 <sup>b</sup>	בְּרָא 145 <sup>b</sup> ; 612 <sup>b</sup> ; 613 <sup>b</sup> ; 738 <sup>a, b</sup> ; 1046 <sup>a</sup> ; 1202 <sup>a</sup> ; 1968 <sup>a</sup>
בְּנִי-בְרַק 434 <sup>a</sup>	בְּעֵלָת 347 <sup>a</sup>	בְּרָאָדָן } 2036 <sup>b</sup>
בְּנִיה 527 <sup>a</sup>	בְּעֵלָת בְּאֵר 347 <sup>a</sup>	בְּרָאִי see בְּרָאִי
בְּנִיה } 434 <sup>a</sup>	בְּעַל תְּמָר 348 <sup>a</sup>	בְּרָאִיהָ 439 <sup>a</sup>
בְּנִיהוּ } 434 <sup>a</sup>	בְּעֵנָא 348 <sup>a</sup>	בְּרָבָר 1143 <sup>a</sup>
בְּנִי רַעְנָן 435 <sup>b</sup>	בְּעֵנָה 348 <sup>a</sup>	בְּרָד 1319 <sup>b</sup> ; 2405 <sup>a</sup>
בְּנִים 593 <sup>a</sup>	בְּעַר 526 <sup>b</sup>	בְּרָד 439 <sup>b</sup>
בְּנִימִין 438 <sup>a</sup>	בְּעַר 1125 <sup>a</sup>	בְּרָה 612 <sup>b</sup> ; 613 <sup>b</sup>
בְּנִינִי 438 <sup>a</sup>	בְּעָרָא 348 <sup>a</sup>	בְּרִיף 407 <sup>a</sup> ; 487 <sup>a</sup>
בְּבִקְעָא } 474 <sup>b</sup>	בְּעָשָׂא 348 <sup>b</sup>	בְּרוּשׁ 512 <sup>b</sup> ; 1111 <sup>b</sup>
בְּבִקְעָה }	בְּעָשָׂה 348 <sup>a</sup>	בְּרוּת 1111 <sup>b</sup>
בֶּן-עַמִּי 434 <sup>a</sup>	בְּץ 2000 <sup>a</sup>	בְּרוּתָהּ } 440 <sup>b</sup>
בְּסוּרְיָה 441 <sup>a</sup>	בְּצָה 2000 <sup>a</sup>	בְּרוּתִי }
בְּסִי 440 <sup>b</sup>	בְּצִי 459 <sup>b</sup>	בְּרוּת 478 <sup>b</sup>
בְּסָר 2838 <sup>a</sup> ; 3050 <sup>a</sup>	בְּצִיר 3050 <sup>a</sup>	
בְּעָה 494 <sup>b</sup>	בְּצַל 1122 <sup>a</sup> ; 2196 <sup>a</sup>	
בְּעִי 2358 <sup>a</sup>	בְּצַלָּל 459 <sup>b</sup>	
בְּעִילָה 458 <sup>b</sup> ; 1997 <sup>a</sup>	בְּצַלּוּת } 417 <sup>a</sup>	
	בְּצַלּוּת }	

**בְּרִזְל** 341<sup>b</sup>; 1348<sup>a</sup>; 1492<sup>a</sup>;  
 2181<sup>a</sup>; 3027<sup>b</sup>  
**בְּרִזְלִי** 410<sup>b</sup>  
**בְּרַח** 1086<sup>b</sup>; 1148<sup>a</sup>  
**בְּרַח** see **בְּרִיחַ**  
**בְּרִי** 439<sup>b</sup>  
**בְּרִי** 440<sup>a</sup>  
**בְּרִיחַ** 401<sup>b</sup>  
**בְּרִיחַ** } 1148<sup>a</sup>; 2154<sup>a</sup>  
**בְּרַחַת** }  
**בְּרִיחַ** 309<sup>a</sup>; 404<sup>a</sup>  
**בְּרִיחָה** 439<sup>b</sup>  
**בְּרִיחַ** 244<sup>b</sup>; 440<sup>a</sup>; 460<sup>b</sup>;  
 699<sup>a</sup>; 727<sup>a</sup>; 728<sup>a,b</sup>;  
 729<sup>b</sup>; 730<sup>a</sup>; 731<sup>a</sup>;  
 746<sup>a</sup>; 2556<sup>b</sup>;  
 3008<sup>b</sup>  
**בְּרִיחַ** 2820<sup>b</sup>  
**בְּרַחַ** 22<sup>b</sup>; 485<sup>b</sup>; 487<sup>a</sup>;  
 1815<sup>a</sup>  
**בְּרַחַ** 1815<sup>a</sup>  
**בְּרַחַ** 1815<sup>a</sup>  
**בְּרַכְאֵל** 402<sup>b</sup>  
**בְּרַכָּה** 439<sup>a</sup>; 487<sup>b</sup>; 658<sup>a</sup>;  
 1881<sup>a</sup>; 2419<sup>b</sup>  
**בְּרַכָּה** 658<sup>a</sup>; 1117<sup>a</sup>; 1610<sup>b</sup>;  
 1808<sup>a</sup>; 2419<sup>b</sup>;  
 2791<sup>a</sup>  
**בְּרַכְיָה** 439<sup>b</sup>  
**בְּרַעַ** 439<sup>a</sup>  
**בְּרַק** 1235<sup>a</sup>; 1892<sup>b</sup>; 2859<sup>a</sup>  
**בְּרַק** 402<sup>b</sup>  
**בְּרַקוֹס** 404<sup>a</sup>  
**בְּרַקוֹן** 2974<sup>a</sup>  
**בְּרַקַת** 2856<sup>b</sup>; 2857<sup>a</sup>  
**בְּרַר** 667<sup>b</sup>; 668<sup>a</sup>; 1143<sup>a</sup>;  
 1981<sup>b</sup>; 2506<sup>b</sup>  
**בְּרַשַׁע** 477<sup>b</sup>  
**בְּשׂוֹר** 441<sup>a</sup>  
**בְּשֵׁל** 494<sup>a</sup>; 2256<sup>b</sup>  
**בְּשֵׁלָם** 478<sup>b</sup>  
**בְּשֵׁם** 381<sup>b</sup>  
**בְּשֵׁם** 381<sup>b</sup>; 2178<sup>b</sup>; 2544<sup>b</sup>;  
 2818<sup>a</sup>; 2840<sup>a</sup>  
**בְּשִׁמַת** 411<sup>a</sup>  
**בְּשִׁן** 411<sup>a</sup>  
**בְּשִׂר** 2039<sup>a</sup>  
**בְּשִׂר** 287<sup>b</sup>; 1118<sup>b</sup>; 2433<sup>a</sup>;  
 2813<sup>b</sup>; 2814<sup>a</sup>;  
 2837<sup>a</sup>  
**בְּשִׂרָה** see **בְּשׂוֹרָה**

**בְּשִׂת** 346<sup>a</sup>; 612<sup>a</sup>; 700<sup>b</sup>;  
 1595<sup>a,b</sup>; 2748<sup>a</sup>;  
 2961<sup>a</sup>  
**בַּת** 210<sup>a</sup>; 663<sup>b</sup>; 2045<sup>a</sup>;  
 2554<sup>b</sup>; 3001<sup>a</sup>  
**בַּת** 414<sup>a</sup>; 1113<sup>a</sup>; 3080<sup>a</sup>  
**בַּת־אֵל** 452<sup>b</sup>; 454<sup>a</sup>  
**בַּת־וֵאל** 454<sup>a</sup>  
**בַּת־וֵאלָה** 1967<sup>b</sup>; 3051<sup>b</sup>  
**בַּת־וֵאלִים** 1967<sup>b</sup>  
**בַּת־יָהּ** 483<sup>a</sup>  
**בַּת־יָהּ** 444<sup>b</sup>; 1972<sup>b</sup>  
**בַּת־רַבִּים** 416<sup>a</sup>  
**בַּת־רוֹחַ** 483<sup>a</sup>  
**בַּת־שֵׁבַע** 416<sup>a</sup>  
**בַּת־שֵׁרַע** 416<sup>a,b</sup>  
**ג**  
**גָּאָה** 2875<sup>b</sup>  
**גָּאוֹאֵל** 1222<sup>a</sup>  
**גָּאוֹנָה** 1050<sup>a</sup>; 2875<sup>b</sup>  
**גָּאוֹן** 1050<sup>a</sup>; 2875<sup>b</sup>  
**גָּאֵל** 340<sup>b</sup>; 1272<sup>b</sup>; 1683<sup>b</sup>;  
 1810<sup>a</sup>; 2022<sup>a</sup>;  
 2416<sup>a</sup>; 2530<sup>a,b</sup>  
**גָּאֵל** 16<sup>a</sup>; 2506<sup>a</sup>; 2555<sup>a</sup>;  
 3036<sup>a</sup>  
**גָּאֵלָה** 1799<sup>a</sup>; 2079<sup>a</sup>; 2080<sup>a</sup>;  
 2530<sup>b</sup>  
**גַּב** 411<sup>a</sup>; 505<sup>a</sup>; 941<sup>a</sup>;  
 2594<sup>b</sup>  
**גַּב** 1390<sup>a</sup>  
**גַּב** 417<sup>a</sup>; 568<sup>a</sup>  
**גַּב** 1907<sup>b</sup>; 1908<sup>b</sup>  
**גַּב** } 829<sup>b</sup>; 1251<sup>a</sup>  
**גַּבִּי** }  
**גַּבְאֵ** 568<sup>a</sup>; 1985<sup>b</sup>; 2000<sup>a</sup>  
**גַּבְהַ** 1049<sup>b</sup>  
**גַּבְהַ** 1050<sup>a</sup>; 1369<sup>a</sup>  
**גַּבְהַ** } 1390<sup>a</sup>  
**גַּבְהַיָּה** }  
**גַּבְוֵל** 503<sup>a</sup>; 511<sup>a</sup>; 1826<sup>b</sup>;  
 1894<sup>a</sup>  
**גַּבְוֵלָה** } 503<sup>a</sup>; 511<sup>a</sup>; 672<sup>a</sup>;  
**גַּבְוֵלָה** } 1826<sup>b</sup>  
**גַּבְוֵר** 145<sup>a</sup>; 255<sup>b</sup>; 312<sup>b</sup>;  
 491<sup>a</sup>; 593<sup>a</sup>; 1224<sup>b</sup>;  
 1264<sup>b</sup>; 1267<sup>a</sup>;  
 1308<sup>a</sup>; 1570<sup>b</sup>;  
 1606<sup>b</sup>; 2189<sup>a</sup>;  
 3045<sup>b</sup>  
**גַּבְוֵרָה** } 2008<sup>a</sup>; 2063<sup>a</sup>  
**גַּבְוֵרָה** }

**גַּבִּי** 1150<sup>b</sup>  
**גַּבִּים** 1180<sup>b</sup>  
**גַּבְיָהּ** 1123<sup>b</sup>  
**גַּבְיַע** 511<sup>b</sup>; 2525<sup>b</sup>  
**גַּבְוֵרָה** 2052<sup>a</sup>; 2513<sup>b</sup>; 2514<sup>a</sup>;  
 2554<sup>b</sup>; 3102<sup>a</sup>  
**גַּבִּישׁ** 709<sup>a</sup>; 764<sup>b</sup>; 2860<sup>a</sup>;  
 2861<sup>b</sup>  
**גַּבֵּל** 511<sup>a</sup>  
**גַּבֵּל** 672<sup>a</sup>; 1180<sup>a</sup>  
**גַּבֵּל** 1180<sup>b</sup>  
**גַּבְוֵלָה** see **גַּבְוֵלָה**  
**גַּבְוֵלִי** 1180<sup>b</sup>  
**גַּבְוֵן** 760<sup>b</sup>  
**גַּבַעַ** 1150<sup>a</sup>; 1180<sup>a</sup>; 1392<sup>b</sup>;  
 1945<sup>b</sup>; 2013<sup>b</sup>  
**גַּבְעָא** 12<sup>a</sup>  
**גַּבְעָה** 1392<sup>a,b</sup>  
**גַּבְעָה** 724<sup>b</sup>; 1224<sup>b</sup>; 1225<sup>a</sup>;  
 2082<sup>a</sup>  
**גַּבְעוֹן** 1225<sup>b</sup>; 1392<sup>b</sup>  
**גַּבְעֵל** 494<sup>b</sup>; 1120<sup>b</sup>  
**גַּבְעַת** 1225<sup>b</sup>  
**גַּבְר** 1050<sup>a</sup>  
**גַּבְר** 145<sup>a</sup>  
**גַּבְר** 145<sup>a</sup>; 1180<sup>b</sup>  
**גַּבְר** 1224<sup>b</sup>  
**גַּבְרָה** see **גַּבְרָה**  
**גַּבְרִיאֵל** 1151<sup>a</sup>  
**גַּבְרַת** 1821<sup>b</sup>; 2067<sup>a</sup>  
**גַּבְרַתוֹן** 1224<sup>b</sup>  
**גַּבְרַת** 1437<sup>a</sup>  
**גַּבְרַת** 710<sup>a</sup>  
**גַּבְרַת** 1152<sup>a</sup>  
**גַּבְרַת** 1151<sup>a</sup>; 1152<sup>a</sup>  
**גַּבְרַת** 3007<sup>b</sup>  
**גַּבְרַתָּה** 1308<sup>a</sup>  
**גַּבְרַת** 769<sup>b</sup>  
**גַּבְרַת** see **גַּבְרַת**  
**גַּבְרַת** 383<sup>a</sup>  
**גַּבְרַת** see **גַּבְרַת**  
**גַּבְרַת** 382<sup>a</sup>  
**גַּבְרַת** } 254<sup>b</sup>; 1150<sup>b</sup>; 1152<sup>a</sup>  
**גַּבְרַתָּה** }  
**גַּבְרַת** } 724<sup>a</sup>; 1294<sup>a</sup>; 1389<sup>b</sup>;  
**גַּבְרַת** } 2026<sup>b</sup>; 2441<sup>b</sup>  
**גַּבְרַתָּה** } 849<sup>a</sup>  
**גַּבְרַתָּה** }  
**גַּבְרַת** see **גַּבְרַת**



גָּדַר 1248<sup>b</sup>; 1797<sup>b</sup>  
 גָּדַר 1153<sup>a</sup>  
 גָּדַר 1153<sup>a</sup>  
 גְּדִיאָל 1153<sup>a</sup>  
 גְּדִיָּה 383<sup>a</sup>  
 גְּדִיָּה 1249<sup>a</sup>  
 גְּדֹל 522<sup>b</sup>; 1050<sup>a</sup>; 1965<sup>a, b</sup>  
 גְּדֹל 1146<sup>b</sup>  
 גְּהַל 1226<sup>b</sup>; 2157<sup>a</sup>  
 גְּדֹל see גְּדוֹל  
 גְּדֹחַ see גְּדִיָּה  
 גְּדִלְיָה 1181<sup>a</sup>  
 גְּדִלְיָה 1226<sup>a</sup>  
 גְּדַע 316<sup>b</sup>; 769<sup>b</sup>  
 גְּדַעוֹן 1226<sup>b</sup>; 1228<sup>b</sup>  
 גְּדַעְנִי 1228<sup>a</sup>  
 גְּדַח 485<sup>b</sup>  
 גְּדַר 669<sup>b</sup>; 1106<sup>b</sup>; 2007<sup>a</sup>  
 גְּדַר 1181<sup>b</sup>  
 גְּדַר } 1182<sup>a</sup>  
 גְּדוֹר }  
 גְּדַר 1106<sup>b</sup>; 1366<sup>b</sup>; 1367<sup>a</sup>  
 גְּדִרָּה 2757<sup>b</sup>  
 גְּדִרָּה 1181<sup>b</sup>; 1366<sup>b</sup>; 1367<sup>a</sup>  
 גְּדִרּוֹת 1181<sup>b</sup>  
 גְּדִרִי 1181<sup>b</sup>  
 גְּדִרְיָם 1182<sup>a</sup>  
 גְּהַח 766<sup>b</sup>  
 גְּהַח 2026<sup>a</sup>  
 גְּיַב 1442<sup>b</sup>  
 גְּיַב 1250<sup>a</sup>; 1907<sup>b</sup>; 1908<sup>b</sup>  
 גְּיַג 1273<sup>a</sup>  
 גְּיַה 492<sup>a</sup>  
 גְּיַזֵּן 1290<sup>a</sup>  
 גְּיַר }  
 גְּיַר } 1215<sup>a</sup>; 1341<sup>a</sup>; 2319<sup>a</sup>  
 גְּיַרְיָה 492<sup>a</sup>; 722<sup>b</sup>  
 גְּיַרְיָם 1273<sup>a</sup>; 2980<sup>a, b</sup>  
 גְּיַרְיָה }  
 גְּיַרְיָה } 569<sup>b</sup>; 855<sup>a</sup>; 1052<sup>b</sup>  
 גְּיַרְיָה }  
 גְּיַרְיָה } 1273<sup>b</sup>  
 גְּיַרְיָה } 1310<sup>b</sup>  
 גְּיַרְיָה } 848<sup>b</sup>  
 גְּיַרְיָה } 492<sup>a</sup>; 722<sup>b</sup>  
 גְּיַרְיָה } 1310<sup>b</sup>; 1895<sup>a</sup>; 2467<sup>b</sup>;  
 גְּיַרְיָה } 3083<sup>a</sup>  
 גְּיַרְיָה } 1895<sup>a</sup>

גְּיַרְיָה 3083<sup>a</sup>  
 גְּיַרְיָה-בְּעַל 1310<sup>b</sup>  
 גְּיַרְיָה }  
 גְּיַרְיָה } 669<sup>b</sup>  
 גְּיַרְיָה } 2093<sup>a</sup>  
 גְּיַרְיָה } 3007<sup>b</sup>  
 גְּיַרְיָה } 769<sup>b</sup>; 2415<sup>b</sup>; 2751<sup>b</sup>  
 גְּיַרְיָה } 1179<sup>b</sup>  
 גְּיַרְיָה } 704<sup>b</sup>; 747<sup>b</sup>; 3051<sup>a</sup>  
 גְּיַרְיָה } 1473<sup>a</sup>; 1907<sup>b</sup>; 1908<sup>b</sup>;  
 גְּיַרְיָה } 2236<sup>a</sup>  
 גְּיַרְיָה } 1180<sup>a</sup>  
 גְּיַרְיָה } 862<sup>b</sup>  
 גְּיַרְיָה } 1179<sup>b</sup>; 1222<sup>a</sup>  
 גְּיַרְיָה } 2936<sup>a</sup>  
 גְּיַרְיָה }  
 גְּיַרְיָה } 1233<sup>a</sup>  
 גְּיַרְיָה }  
 גְּיַרְיָה } see גְּיַרְיָה  
 גְּיַרְיָה } 432<sup>a</sup>  
 גְּיַרְיָה } see גְּיַרְיָה  
 גְּיַרְיָה }  
 גְּיַרְיָה } 671<sup>b</sup>  
 גְּיַרְיָה }  
 גְּיַרְיָה } 1153<sup>b</sup>  
 גְּיַרְיָה } 1153<sup>b</sup>  
 גְּיַרְיָה } see גְּיַרְיָה  
 גְּיַרְיָה } 1153<sup>b</sup>; 1394<sup>a</sup>; 1909<sup>a</sup>;  
 גְּיַרְיָה } 3045<sup>a</sup>  
 גְּיַרְיָה } 2804<sup>b</sup>  
 גְּיַרְיָה } 1228<sup>b</sup>  
 גְּיַרְיָה } 1162<sup>a</sup>  
 גְּיַרְיָה }  
 גְּיַרְיָה } 1755<sup>a</sup>  
 גְּיַרְיָה }  
 גְּיַרְיָה } see גְּיַרְיָה  
 גְּיַרְיָה } 1232<sup>a</sup>  
 גְּיַרְיָה } 591<sup>a</sup>; 1893<sup>b</sup>; 2408<sup>a</sup>  
 גְּיַרְיָה } see גְּיַרְיָה  
 גְּיַרְיָה } 1219<sup>b</sup>  
 גְּיַרְיָה } 1350<sup>b</sup>; 3081<sup>b</sup>  
 גְּיַרְיָה } see גְּיַרְיָה  
 גְּיַרְיָה } 1320<sup>b</sup>  
 גְּיַרְיָה } 1229<sup>b</sup>  
 גְּיַרְיָה } 2597<sup>b</sup>; 3082<sup>b</sup>  
 גְּיַרְיָה } 1163<sup>a</sup>; 1231<sup>a</sup>; 3082<sup>b</sup>;  
 גְּיַרְיָה } see also גְּיַרְיָה  
 גְּיַרְיָה } 1275<sup>a</sup>; 1348<sup>a</sup>; 2415<sup>b</sup>;  
 גְּיַרְיָה } 2416<sup>a</sup>; 2814<sup>b</sup>  
 גְּיַרְיָה } 2813<sup>b</sup>; 2814<sup>a</sup>

גְּיַרְיָה } 65<sup>a</sup>; 459<sup>a</sup>; 852<sup>a</sup>;  
 גְּיַרְיָה } 1052<sup>a</sup>; 2196<sup>b</sup>;  
 גְּיַרְיָה } 2415<sup>b</sup>; 2581<sup>a, b</sup>  
 גְּיַרְיָה } 2581<sup>a</sup>  
 גְּיַרְיָה } see גְּיַרְיָה  
 גְּיַרְיָה } 1231<sup>b</sup>  
 גְּיַרְיָה } 511<sup>b</sup>  
 גְּיַרְיָה } 612<sup>a</sup>  
 גְּיַרְיָה } 569<sup>b</sup>  
 גְּיַרְיָה } 2751<sup>b</sup>  
 גְּיַרְיָה } 1234<sup>a</sup>; 2597<sup>a, b</sup>;  
 גְּיַרְיָה } 2900<sup>b</sup>  
 גְּיַרְיָה } 1121<sup>a</sup>; 1163<sup>a</sup>; 2594<sup>b</sup>  
 גְּיַרְיָה } 724<sup>a</sup>  
 גְּיַרְיָה } 1167<sup>b</sup>; 1183<sup>a</sup>; 2377<sup>a</sup>  
 גְּיַרְיָה } 1167<sup>a</sup>  
 גְּיַרְיָה } 1276<sup>b</sup>  
 גְּיַרְיָה } 688<sup>a</sup>; 2597<sup>a</sup>; 3081<sup>b</sup>  
 גְּיַרְיָה } 1154<sup>a</sup>  
 גְּיַרְיָה } 1229<sup>b</sup>  
 גְּיַרְיָה } 833<sup>b</sup>  
 גְּיַרְיָה } 897<sup>a</sup>; 1163<sup>a</sup>; 1229<sup>b</sup>;  
 גְּיַרְיָה } 1350<sup>b</sup>  
 גְּיַרְיָה } 1229<sup>b</sup>; 1231<sup>a</sup>; 2068<sup>b</sup>  
 גְּיַרְיָה } 1983<sup>a</sup>; 2475<sup>b</sup>; 3126<sup>a</sup>  
 גְּיַרְיָה } 242<sup>a</sup>; 2627<sup>a</sup>  
 גְּיַרְיָה } 765<sup>a</sup>  
 גְּיַרְיָה } 1173<sup>b</sup>  
 גְּיַרְיָה } 435<sup>a</sup>  
 גְּיַרְיָה } 445<sup>b</sup>; 1173<sup>b</sup>  
 גְּיַרְיָה } 817<sup>a</sup>  
 גְּיַרְיָה } 1231<sup>b</sup>  
 גְּיַרְיָה } 511<sup>a</sup>; 3076<sup>b</sup>  
 גְּיַרְיָה } 547<sup>b</sup>; 584<sup>a</sup>; 1339<sup>a</sup>  
 גְּיַרְיָה } 1183<sup>b</sup>  
 גְּיַרְיָה } 1168<sup>a</sup>  
 גְּיַרְיָה } 1276<sup>b</sup>  
 גְּיַרְיָה } 1183<sup>b</sup>  
 גְּיַרְיָה } 1174<sup>a</sup>; 1808<sup>a</sup>  
 גְּיַרְיָה } 748<sup>a</sup>; 2972<sup>a</sup>  
 גְּיַרְיָה } 2972<sup>a</sup>  
 גְּיַרְיָה } 748<sup>a</sup>  
 גְּיַרְיָה } 1215<sup>b</sup>

גְּנֵה } 1174<sup>a</sup>  
 גְּנֵה }  
 גְּנֵז 182<sup>b</sup>; 518<sup>a</sup>; 554<sup>b</sup>;  
 560<sup>b</sup>  
 גְּנֵז } 3007<sup>b</sup>  
 גְּנֵז }  
 גְּנֵזָה 3007<sup>b</sup>; 3008<sup>a, b</sup>  
 גְּנֵתוֹן } 1232<sup>a</sup>  
 גְּנֵתוֹי }  
 גְּנֵה 1248<sup>b</sup>  
 גְּעַל 6<sup>b</sup>; 818<sup>a</sup>; 2541<sup>a</sup>  
 גְּעַל 1150<sup>a</sup>  
 גְּעַר 2535<sup>a</sup>  
 גְּעִרָה 2535<sup>a</sup>  
 גְּעַשׂ 1150<sup>a</sup>  
 גְּעִתָּם 1175<sup>b</sup>  
 גְּה 1390<sup>a</sup>  
 גְּפֵן 2237<sup>b</sup>; 2821<sup>b</sup>; 3049<sup>b</sup>  
 גְּפֵר 1279<sup>b</sup>  
 גְּפִרִית 522<sup>b</sup>; 1279<sup>b</sup>  
 גְּר } 2467<sup>b</sup>; 2468<sup>a</sup>; 2556<sup>b</sup>;  
 גְּר } 2865<sup>a, b</sup>; 2866<sup>a</sup>  
 גְּר see גְּרֵר  
 גְּרָא 1217<sup>a</sup>  
 גְּרָב 2706<sup>a</sup>  
 גְּרָב 1175<sup>a</sup>  
 גְּרָרוֹה 2129<sup>a</sup>  
 גְּרָשִׁי 1232<sup>a</sup>  
 גְּרָה 605<sup>b</sup>; 1217<sup>b</sup>; 3081<sup>a</sup>  
 גְּרָה see גְּרֵר  
 גְּרִוֹן } 2093<sup>a</sup>; 2129<sup>a</sup>  
 גְּרִוֹן }  
 גְּרוֹת 1219<sup>b</sup>; 1470<sup>a</sup>  
 גְּרוֹזִים 1218<sup>a</sup>  
 גְּרוֹזִי see גְּרוֹרִי  
 גְּרוֹן 341<sup>a</sup>; 2998<sup>b</sup>  
 גְּרָם } 287<sup>b</sup>; 495<sup>b</sup>  
 גְּרָם }  
 גְּרָמִי 1175<sup>b</sup>  
 גְּרָן 606<sup>a</sup>; 722<sup>a</sup>; 2196<sup>b</sup>;  
 2975<sup>b</sup>  
 גְּרָן see גְּרָוֹן  
 גְּרָע 849<sup>a</sup>  
 גְּרָר 605<sup>b</sup>  
 גְּרָר 1217<sup>b</sup>  
 גְּרָשׁ 1219<sup>a</sup>  
 גְּרָשָׁה 1049<sup>b</sup>  
 גְּרָשָׁם 1219<sup>a</sup>

גְּרָשׁוֹן 1219<sup>a</sup>  
 גְּרָשׁוֹר 522<sup>a</sup>; 1219<sup>b</sup>  
 גְּרָשׁוֹרִי 269<sup>b</sup>; 1220<sup>a</sup>  
 גְּרָשָׁם 492<sup>a</sup>; 1175<sup>b</sup>; 1219<sup>b</sup>;  
 2525<sup>b</sup>; 2781<sup>a</sup>  
 גְּרָשְׁמִי 1175<sup>b</sup>; 1219<sup>b</sup>  
 גְּרָשָׁן 1280<sup>a</sup>; 1281<sup>a</sup>  
 גְּרָשָׁא 1232<sup>a</sup>  
 גְּרָת 1177<sup>a</sup>; 2045<sup>a</sup>; 3086<sup>b</sup>  
 גְּרָת הַחֶפֶר } 1178<sup>a</sup>; 1232<sup>a</sup>  
 גְּרָת הַחֶפֶר }  
 גְּרָתִי 1232<sup>a</sup>; 2095<sup>a</sup>  
 גְּרָתִים 1232<sup>a</sup>  
 גְּרָתִית 2488<sup>a</sup>  
 גְּרָר 1221<sup>b</sup>  
 גְּרָרְמוֹן 1178<sup>a</sup>; 1221<sup>b</sup>  
 גְּרָרְמוֹן } 1178<sup>a</sup>; 1232<sup>a</sup>  
 גְּרָרְמוֹן }  
 גְּרָרְמִי 1232<sup>a</sup>; 2095<sup>a</sup>  
 גְּרָרְמִים 1232<sup>a</sup>  
 גְּרָרְמִית 2488<sup>a</sup>  
 גְּרָרְמִי 1221<sup>b</sup>  
 גְּרָרְמוֹן 1178<sup>a</sup>; 1221<sup>b</sup>  
 דְּ  
 דְּאָבוֹן 2390<sup>b</sup>  
 דְּאָג 577<sup>b</sup>  
 דְּאָג } 867<sup>b</sup>  
 דְּאָג }  
 דְּאָגָה 577<sup>b</sup>; 1354<sup>a, b</sup>  
 דְּאָה 477<sup>b</sup>; 1121<sup>a</sup>; 3062<sup>b</sup>  
 דְּאָה see רְאָה  
 דָּב } 417<sup>b</sup>  
 דָּב }  
 דָּבָה 818<sup>a</sup>; 2814<sup>b</sup>  
 דְּבוֹרָה } 423<sup>a</sup>; 813<sup>b</sup>; 1423<sup>a</sup>  
 דְּבוֹרָה }  
 דְּבוֹן } 872<sup>b</sup>  
 דְּבוֹן }  
 דְּבוֹרִי } 604<sup>b</sup>; 813<sup>b</sup>; 1405<sup>a, b</sup>;  
 דְּבוֹרִי } 2198<sup>b</sup>; 2930<sup>b</sup>;  
 דְּבוֹרִי } 2931<sup>a, b</sup>; 2932<sup>a</sup>;  
 דְּבוֹרִי } 2933<sup>b</sup>; 2938<sup>b</sup>  
 דְּבִלָּה 843<sup>b</sup>  
 דְּבִלָּה 1109<sup>b</sup>; 1122<sup>b</sup>; 1426<sup>a</sup>  
 דְּבִלָּם 843<sup>b</sup>  
 דְּבִלָּתִים see בֵּית הַדְּבִלָּתִים  
 דְּבִק 668<sup>b</sup>; 1338<sup>a</sup>  
 דְּבִק 2821<sup>a</sup>  
 דְּבִק 1121<sup>b</sup>; 1338<sup>a</sup>  
 דְּבִר 174<sup>b</sup>; 1253<sup>a</sup>; 1983<sup>a</sup>;  
 2112<sup>a</sup>; 2198<sup>b</sup>;  
 2411<sup>a</sup>; 2459<sup>a</sup>;  
 2515<sup>a</sup>; 2550<sup>b</sup>  
 דְּבִר 65<sup>a</sup>; 423<sup>a</sup>; 496<sup>a</sup>; 533<sup>a</sup>;  
 577<sup>b</sup>; 679<sup>b</sup>; 730<sup>a</sup>;  
 789<sup>b</sup>; 817<sup>a</sup>; 883<sup>b</sup>;  
 905<sup>a</sup>; 1439<sup>a</sup>;  
 1982<sup>a</sup>; 2009<sup>a</sup>

2422<sup>b</sup>; 2459<sup>a</sup>;  
 2534<sup>b</sup>; 2581<sup>b</sup>;  
 2839<sup>b</sup>; 3105<sup>a</sup>  
 דְּבִר 2094<sup>b</sup>; 2348<sup>a</sup>; 2403<sup>a</sup>;  
 2405<sup>a</sup>  
 דְּבִר see דְּבִיר  
 דְּבִרָה 943<sup>a</sup>; 2200<sup>b</sup>  
 דְּבִרָה see דְּבוֹרָה  
 דְּבִרָה 2774<sup>b</sup>  
 דְּבִרִי 843<sup>b</sup>  
 דְּבִרִית 776<sup>a</sup>  
 דְּבִשׁ 1123<sup>a</sup>; 1418<sup>b</sup>; 2237<sup>b</sup>;  
 3050<sup>a</sup>  
 דְּבִשְׁת 528<sup>a</sup>; 776<sup>a</sup>  
 דְּבִי } 776<sup>b</sup>; 777<sup>a</sup>; 1114<sup>b</sup>;  
 דְּבִי } 1115<sup>a</sup>; 3082<sup>b</sup>  
 דְּבִיָּה 1114<sup>b</sup>; 1115<sup>a</sup>; 3082<sup>b</sup>  
 דְּבוֹן 776<sup>b</sup>; 2389<sup>b</sup>  
 דְּבוֹל 310<sup>b</sup>; 3070<sup>b</sup>  
 דְּבוֹן 720<sup>b</sup>; 722<sup>a</sup>  
 דְּבוֹר 2813<sup>b</sup>  
 דְּבוֹר 2923<sup>b</sup>  
 דְּבוֹרָה 1248<sup>a</sup>  
 דְּבוֹרִי } 816<sup>b</sup>  
 דְּבוֹרִי }  
 דְּבוֹרִים 816<sup>b</sup>  
 דְּבוֹרִים } 867<sup>b</sup>  
 דְּבוֹרִים }  
 דְּבוֹרָא 819<sup>b</sup>  
 דְּבוֹאג see הָאָג  
 דְּבוֹב 2399<sup>b</sup>  
 דְּבוֹב see דָּב  
 דְּבוֹג 1115<sup>b</sup>  
 דְּבוֹה 1116<sup>a</sup>; 1419<sup>a</sup>  
 דְּבוֹר } 432<sup>b</sup>; 1981<sup>a</sup>; 2555<sup>a</sup>;  
 דְּבוֹר } 3035<sup>b</sup>  
 דְּבוֹר 412<sup>b</sup>; 413<sup>a</sup>; 541<sup>a</sup>;  
 1793<sup>b</sup>; 2423<sup>a</sup>  
 דְּבוֹר } 790<sup>b</sup>  
 דְּבוֹר }  
 דְּבוֹרָה 332<sup>b</sup>; 2555<sup>a</sup>  
 דְּבוֹרוֹ 867<sup>b</sup>  
 דְּבוֹרָה 867<sup>b</sup>  
 דְּבוֹרִי 1981<sup>a</sup>  
 דְּבוֹרִי 867<sup>b</sup>  
 דְּבוֹרָה 1468<sup>a</sup>  
 דְּבוֹרָה 2783<sup>a, b</sup>  
 דְּבוֹרִית 2506<sup>b</sup>; 3072<sup>b</sup>  
 דְּבוֹרִי 1086<sup>b</sup>

דָּוִד see דָּוִד  
 דּוֹכִיפֶת 1419<sup>a</sup>; 1839<sup>b</sup>  
 דּוֹמָה 882<sup>a</sup>  
 דּוֹמֶשֶׁק see דּוֹמֶשֶׁק  
 דּוֹנָג 3075<sup>b</sup>  
 דּוֹר 381<sup>a</sup>  
 דּוֹר }  
 דּוֹר } 70<sup>b</sup>; 1199<sup>a</sup>  
 דּוֹר }  
 דּוֹר } 869<sup>b</sup>; 1326<sup>a</sup>  
 דּוֹרָא 883<sup>a</sup>  
 דּוֹש }  
 דּוֹש } 2511<sup>b</sup>; 2975<sup>b</sup>; 3156<sup>a</sup>  
 דּוֹש }  
 דּוֹש }  
 דּוֹתָה } 2204<sup>b</sup>  
 דּוֹחָה }  
 דּוֹחָה }  
 דּוֹחָה } 2055<sup>a</sup>  
 דּוֹ 1267<sup>a</sup>  
 דּוֹבּוֹן } 843<sup>b</sup>  
 דּוֹבּוֹן }  
 דּוֹבּוֹן } 1115<sup>b</sup>  
 דּוֹבּוֹן } 477<sup>b</sup>; 2697<sup>a</sup>; 2738<sup>a</sup>  
 דּוֹבּוֹן } 1469<sup>a</sup>  
 דּוֹבּוֹן } 866<sup>b</sup>  
 דּוֹבּוֹן } 1051<sup>b</sup>; 2408<sup>b</sup>  
 דּוֹבּוֹן }  
 דּוֹבּוֹן } 1965<sup>a</sup>  
 דּוֹבּוֹן } 849<sup>b</sup>  
 דּוֹבּוֹן } 849<sup>b</sup>  
 דּוֹבּוֹן } see רִיפֶת  
 דּוֹבּוֹן } 1136<sup>b</sup>; 2787<sup>a</sup>  
 דּוֹבּוֹן }  
 דּוֹבּוֹן }  
 דּוֹבּוֹן } 854<sup>b</sup>; 2511<sup>a</sup>; 3155<sup>b</sup>;  
 דּוֹבּוֹן } 3156<sup>a</sup>  
 דּוֹבּוֹן }  
 דּוֹבּוֹן }  
 דּוֹבּוֹן } 526<sup>b</sup>  
 דּוֹבּוֹן } 706<sup>a</sup>  
 דּוֹבּוֹן } 523<sup>a</sup>  
 דּוֹבּוֹן } 2527<sup>b</sup>  
 דּוֹבּוֹן } 2538<sup>a</sup>  
 דּוֹבּוֹן }  
 דּוֹבּוֹן } 2420<sup>a</sup>; 2427<sup>a</sup>  
 דּוֹבּוֹן } 1320<sup>b</sup>; 2399<sup>b</sup>; 2420<sup>a</sup>;  
 דּוֹבּוֹן } 2977<sup>a</sup>  
 דּוֹבּוֹן }  
 דּוֹבּוֹן } 526<sup>b</sup>  
 דּוֹבּוֹן }  
 דּוֹבּוֹן } 819<sup>b</sup>  
 דּוֹבּוֹן }

דּוֹלִיָּה 820<sup>b</sup>  
 דּוֹלִיָּה 513<sup>b</sup>  
 דּוֹלִיָּה 941<sup>b</sup>  
 דּוֹלִיָּה 849<sup>a</sup>  
 דּוֹלִיָּה 778<sup>a</sup>  
 דּוֹלִיָּה 1107<sup>a</sup>; 1468<sup>a</sup>  
 דּוֹלִיָּה 1107<sup>b</sup>; 1468<sup>a</sup>  
 דּוֹלִיָּה 869<sup>a</sup>; 1175<sup>b</sup>; 1435<sup>a</sup>;  
 דּוֹלִיָּה } 1861<sup>b</sup>; 3122<sup>b</sup>  
 דּוֹלִיָּה } 488<sup>b</sup>; 490<sup>a</sup>; 675<sup>b</sup>;  
 דּוֹלִיָּה } 730<sup>a</sup>; 1272<sup>b</sup>;  
 דּוֹלִיָּה } 2404<sup>a</sup>; 3050<sup>a</sup>  
 דּוֹלִיָּה 694<sup>b</sup>; 1098<sup>b</sup>; 2794<sup>b</sup>;  
 דּוֹלִיָּה } 2972<sup>b</sup>  
 דּוֹלִיָּה 145<sup>b</sup>; 146<sup>a</sup>; 1098<sup>b</sup>;  
 דּוֹלִיָּה } 1264<sup>a</sup>; 1450<sup>a</sup>;  
 דּוֹלִיָּה } 1983<sup>a</sup>  
 דּוֹלִיָּה 1094<sup>a</sup>; 1126<sup>b</sup>  
 דּוֹלִיָּה 2854<sup>b</sup>  
 דּוֹלִיָּה 882<sup>b</sup>  
 דּוֹלִיָּה 849<sup>a</sup>; 2593<sup>b</sup>  
 דּוֹלִיָּה 2923<sup>b</sup>  
 דּוֹלִיָּה 769<sup>a</sup>  
 דּוֹלִיָּה }  
 דּוֹלִיָּה } 778<sup>a</sup>; 929<sup>b</sup>  
 דּוֹלִיָּה }  
 דּוֹ 781<sup>a</sup>  
 דּוֹ see דּוֹבּוֹן  
 דּוֹ 787<sup>b</sup>  
 דּוֹ 849<sup>b</sup>  
 דּוֹ 787<sup>b</sup>  
 דּוֹ } 782<sup>b</sup>  
 דּוֹ }  
 דּוֹ 787<sup>b</sup>  
 דּוֹ 2198<sup>a</sup>  
 דּוֹ 834<sup>b</sup>  
 דּוֹ 1069<sup>a</sup>  
 דּוֹ 766<sup>a</sup>; 1815<sup>b</sup>; 2191<sup>a</sup>;  
 דּוֹ } 2581<sup>b</sup>; 2702<sup>b</sup>  
 דּוֹ 869<sup>b</sup>  
 דּוֹ 883<sup>b</sup>  
 דּוֹ 767<sup>b</sup>  
 דּוֹ 849<sup>a</sup>  
 דּוֹ 526<sup>b</sup>  
 דּוֹ 819<sup>b</sup>  
 דּוֹ 676<sup>a</sup>; 1984<sup>b</sup>  
 דּוֹ see דּוֹר  
 דּוֹ } 6<sup>b</sup>; 978<sup>a</sup>  
 דּוֹ }  
 דּוֹ 1248<sup>b</sup>

דּוֹ 788<sup>b</sup>  
 דּוֹ 2974<sup>a</sup>; 2975<sup>a</sup>  
 דּוֹ 2838<sup>a</sup>  
 דּוֹ 1881<sup>b</sup>; 2874<sup>a</sup>  
 דּוֹ 788<sup>a</sup>  
 דּוֹ 1248<sup>a</sup>; 2975<sup>b</sup>  
 דּוֹ 706<sup>a</sup>; 769<sup>b</sup>; 799<sup>b</sup>;  
 דּוֹ } 1421<sup>b</sup>; 1982<sup>a</sup>;  
 דּוֹ } 2200<sup>b</sup>; 2263<sup>a</sup>;  
 דּוֹ } 2411<sup>a</sup>; 3075<sup>b</sup>  
 דּוֹ 788<sup>a</sup>; 2077<sup>a</sup>  
 דּוֹ 246<sup>b</sup>  
 דּוֹ 788<sup>a</sup>  
 דּוֹ 789<sup>a</sup>  
 דּוֹ 578<sup>a</sup>; 687<sup>a</sup>; 1049<sup>b</sup>;  
 דּוֹ } 1472<sup>b</sup>; 2515<sup>a</sup>  
 דּוֹ 522<sup>b</sup>  
 דּוֹ 1293<sup>a</sup>; 1375<sup>a</sup>; 2947<sup>a</sup>  
 דּוֹ 27<sup>b</sup>  
 דּוֹ 1101<sup>b</sup>  
 דּוֹ 1983<sup>a</sup>  
 דּוֹ 1293<sup>a</sup>; 2947<sup>a</sup>  
 דּוֹ } 870<sup>b</sup>  
 דּוֹ }  
 דּוֹ }  
 דּוֹ 78<sup>b</sup>; 1311<sup>a</sup>  
 דּוֹ see דּוֹר  
 דּוֹ } 5<sup>a</sup>; 3045<sup>b</sup>  
 דּוֹ }  
 דּוֹ 894<sup>a</sup>  
 דּוֹ } 1367<sup>a</sup>  
 דּוֹ }  
 דּוֹ 1307<sup>a</sup>; 1456<sup>a</sup>; 2026<sup>a</sup>;  
 דּוֹ } 2102<sup>a</sup>  
 דּוֹ 2026<sup>a</sup>  
 דּוֹ 2026<sup>a</sup>  
 דּוֹ 1389<sup>b</sup>; 2026<sup>a</sup>; 2488<sup>a</sup>;  
 דּוֹ } 2822<sup>a</sup>  
 דּוֹ 1316<sup>a</sup>  
 דּוֹ } 1319<sup>a</sup>  
 דּוֹ }  
 דּוֹ 1314<sup>a</sup>  
 דּוֹ 1314<sup>a</sup>  
 דּוֹ 1314<sup>a</sup>  
 דּוֹ 1467<sup>a</sup>  
 דּוֹ } 1316<sup>a</sup>  
 דּוֹ }  
 דּוֹ 2103<sup>b</sup>  
 דּוֹ 1006<sup>a</sup>; 1314<sup>b</sup>

הָדָר 678<sup>b</sup>; 724<sup>a</sup>; 1086<sup>a</sup>  
הָדָר 1050<sup>a</sup>; 1235<sup>b</sup>; 1278<sup>b</sup>  
הַדְרָה 1235<sup>b</sup>  
הַדְרָם see הַדְרָם  
הַדְרָעָן 1314<sup>a</sup>  
הַנָּא } 1204<sup>a</sup>; 1535<sup>a</sup>  
הַנָּה }  
הוֹר 1235<sup>b</sup>; 1278<sup>b</sup>; 1402<sup>b</sup>;  
1418<sup>b</sup>  
הוֹרְנָה 1403<sup>a</sup>  
הוֹרְנָה 1403<sup>a</sup>  
הוֹרְנָה 1403<sup>a</sup>  
הוֹרְנָה 1403<sup>a</sup>  
הוֹרְנָה 1403<sup>a</sup>  
הַנָּה see הַנָּא  
הַנָּה 540<sup>b</sup>; 2122<sup>b</sup>; 2155<sup>a</sup>  
הוֹהֵם 1403<sup>a</sup>  
הוֹר 78<sup>b</sup>  
הוֹם 852<sup>a</sup>  
הוֹמָם 1417<sup>b</sup>  
הוֹן 2590<sup>b</sup>  
הוֹשִׁיעַ 1431<sup>a</sup>; 2759<sup>b</sup>  
הוֹשִׁיעַ 1424<sup>a</sup>; 1431<sup>a</sup>; 1743<sup>b</sup>;  
2202<sup>a</sup>  
הוֹשִׁיעָה 1431<sup>a</sup>  
הוֹתִיר 1434<sup>a</sup>  
הַיָּה 1087<sup>a</sup>; 1204<sup>b</sup>; 1254<sup>b</sup>;  
1267<sup>b</sup>; 1336<sup>a</sup>;  
1535<sup>a</sup>; 2515<sup>b</sup>  
הַיָּה 540<sup>b</sup>  
הַיָּבֵל 1405<sup>b</sup>; 1438<sup>a</sup>; 2208<sup>a</sup>;  
2930<sup>a,b</sup>; 2931<sup>a,b</sup>;  
2932<sup>b</sup>; 2933<sup>b</sup>;  
2935<sup>b</sup>; 2938<sup>b</sup>  
הַיָּלֵל 800<sup>a</sup>  
הַיָּמָן 1374<sup>b</sup>  
הַיָּן 1393<sup>a</sup>; 3080<sup>a</sup>  
הַיָּרָה 2767<sup>a</sup>  
הַל } 459<sup>a</sup>; 1141<sup>a</sup>; 1395<sup>b</sup>  
הַלְאָה }  
הַלִּיקָה 3075<sup>b</sup>  
הַלְף 522<sup>b</sup>; 706<sup>a</sup>; 1051<sup>b</sup>;  
1121<sup>b</sup>; 1141<sup>a</sup>;  
1248<sup>a</sup>; 1344<sup>a</sup>;  
2919<sup>b</sup>; 3076<sup>a</sup>  
הַלְף 3007<sup>b</sup>  
הַלְף 769<sup>a,b</sup>; 2994<sup>a</sup>  
הַלֵּל 491<sup>a</sup>; 587<sup>a</sup>; 680<sup>b</sup>;  
1105<sup>a</sup>; 1239<sup>a</sup>;  
1323<sup>a</sup>; 1445<sup>a</sup>;  
1941<sup>b</sup>; 1960<sup>b</sup>;  
2256<sup>b</sup>

הַלֵּל 1393<sup>a</sup>  
הַלֵּם 1370<sup>a</sup>  
הַלֵּם 1395<sup>b</sup>  
הַלְמִית 1325<sup>b</sup>  
הַם 1324<sup>a</sup>  
הַמְדָהּ see מְדָהּ  
הַמָּה 697<sup>b</sup>; 764<sup>b</sup>; 1306<sup>b</sup>  
הַמוֹן } 17<sup>b</sup>; 691<sup>b</sup>; 1325<sup>b</sup>;  
הַמֶּן } 2154<sup>b</sup>; 2590<sup>b</sup>  
הַמְלָכָה see מְלָכָה  
הַמוֹן גּוּג 1332<sup>b</sup>  
הַמוֹנָה 1332<sup>b</sup>  
הַמְרִיעַ see הַמְרִיעַ  
הַמְלָעַ see מְלָעַ  
הַמֶּן see הַמוֹן  
הַמֶּן 1324<sup>b</sup>  
הַמְרִיעַ } 589<sup>a</sup>  
הַמְרִיעַ }  
הַמָּה 1395<sup>b</sup>  
הַמְנָה 2556<sup>b</sup>  
הַמֶּם 1393<sup>a</sup>; 2628<sup>a</sup>  
הַמְעַ 1374<sup>b</sup>  
הַמְפָּ 594<sup>a</sup>; 706<sup>a</sup>; 1147<sup>a</sup>  
הַמְלָפּוּנִי see מְלָפּוּנִי  
הַמְקוֹץ see קוֹץ  
הַר 1066<sup>b</sup>; 1225<sup>a</sup>; 1376<sup>b</sup>;  
1392<sup>a,b</sup>  
הַר 1421<sup>a</sup>; 1810<sup>b</sup>; 3076<sup>a</sup>  
הַרָּא 1337<sup>a</sup>  
הַרְג 288<sup>a</sup>; 746<sup>a</sup>; 2094<sup>a</sup>  
הַרְה 5<sup>a</sup>; 696<sup>a</sup>  
הַרְסָה 2625<sup>b</sup>  
הַרְס 1421<sup>b</sup>  
הַרְן 1337<sup>a</sup>  
הַרְס 517<sup>a</sup>  
הַרְס 302<sup>a</sup>; 665<sup>a,b</sup>; 1491<sup>a</sup>;  
1492<sup>a</sup>  
הַרְר 1392<sup>b</sup>  
הַרְרִי } 1337<sup>a</sup>  
הַרְרִי }  
הַרְרִי }  
הַרְס 1342<sup>a</sup>  
הַרְסָה 1343<sup>b</sup>  
הַרְתֵּל 2072<sup>b</sup>  
הַרְתָּ 1456<sup>a</sup>  
  
הַ }  
הַן 3046<sup>b</sup>  
הַב 2871<sup>b</sup>; 3044<sup>a</sup>

רַי 2959<sup>a</sup>  
רַיָּהּ 3044<sup>b</sup>  
רַיָּהּ 3045<sup>b</sup>  
רַפְסִי 3058<sup>a</sup>  
רַשְׁטִי 2961<sup>b</sup>; 3046<sup>a</sup>  
רַשְׁטִי 3046<sup>b</sup>  
  
זָאב 1548<sup>b</sup>; 2201<sup>a</sup>; 3099<sup>b</sup>;  
3133<sup>b</sup>  
זָהָת 585<sup>a</sup>; 1375<sup>b</sup>; 1376<sup>a</sup>;  
1559<sup>a</sup>; 2745<sup>b</sup>  
זָבֵר 944<sup>a</sup>; 3135<sup>a</sup>  
זָבֵר 3128<sup>a</sup>  
זָבֵרִי 3128<sup>b</sup>; 3134<sup>a</sup>  
זָבֵרִיָּאל 3128<sup>a,b</sup>  
זָבֵרִיהַּ } 3128<sup>a</sup>; 3133<sup>b</sup>  
זָבֵרִיהַּ }  
זָבֵרֵב 423<sup>b</sup>; 1120<sup>b</sup>; 1473<sup>a</sup>  
זָבֵרֵב 3128<sup>b</sup>  
זָבֵרֵב 3128<sup>b</sup>  
זָבֵל } 423<sup>b</sup>; 3134<sup>b</sup>  
זָבֵל }  
זָבֵלֵוֹן } 1623<sup>a</sup>; 3135<sup>a</sup>  
זָבֵלֵוֹן }  
זָבֵלֵוֹן }  
זָבֵלֵנִי 3135<sup>a</sup>  
זָבַח 106<sup>b</sup>  
זָבַח 2639<sup>a</sup>; 2642<sup>b</sup>; 2643<sup>a</sup>;  
2644<sup>b</sup>; 3132<sup>b</sup>  
זָבִי 3128<sup>b</sup>  
זָבִיָּהּ 3134<sup>a</sup>  
זָבִיָּנָה 3134<sup>a</sup>  
זָבֵל 3135<sup>a</sup>  
זָבֵל see זָבֵל  
זָבֵלֵוֹן see זָבֵלֵוֹן  
זָבֵן 1153<sup>b</sup>  
זָג 1793<sup>b</sup>  
זָד 2438<sup>b</sup>  
זָה 1106<sup>a</sup>  
זָהָב 111<sup>b</sup>; 709<sup>a</sup>; 1087<sup>b</sup>;  
1274<sup>a</sup>; 2045<sup>a</sup>;  
3077<sup>a</sup>  
זָהָם 3131<sup>b</sup>  
זָהָר 2773<sup>b</sup>; 2921<sup>b</sup>  
זָר 2411<sup>a</sup>  
זָר see זָר  
זָרֵב 1542<sup>b</sup>; 2399<sup>b</sup>  
זָרֵב 1542<sup>b</sup>

זרד } 2438<sup>b</sup>  
 זרד  
 זרזים 3159<sup>b</sup>  
 זרחת 3155<sup>a</sup>  
 זריח 721<sup>b</sup>  
 זרן 2525<sup>a</sup>  
 זרר 2108<sup>b</sup>; 2865<sup>a</sup>; 2866<sup>b</sup>  
 זרא 3133<sup>a</sup>  
 זחל 2561<sup>a</sup>; 2737<sup>b</sup>; 2738<sup>a</sup>;  
 3109<sup>a</sup>  
 זחלה 3155<sup>a</sup>  
 זיר 541<sup>b</sup>; 724<sup>a</sup>; 3153<sup>a</sup>  
 זיז 17<sup>b</sup>; 3084<sup>a</sup>  
 זיזא 3084<sup>a</sup>; 3153<sup>a</sup>  
 זיזה 3153<sup>a</sup>  
 זיקא 3153<sup>a</sup>  
 זיע 3148<sup>b</sup>  
 זיה 3152<sup>b</sup>  
 זיפה 3152<sup>b</sup>  
 זיקה }  
 זק } 514<sup>a</sup>; 1112<sup>b</sup>  
 זק  
 זר 1122<sup>b</sup>; 2181<sup>b</sup>; 2184<sup>a</sup>;  
 2185<sup>b</sup>  
 זיהן 3148<sup>a</sup>  
 זכה 668<sup>a</sup>  
 זכר 1470<sup>b</sup>  
 זכוכית 709<sup>a</sup>; 764<sup>b</sup>; 1232<sup>a</sup>;  
 2860<sup>a</sup>; 2862<sup>b</sup>  
 זכור 1971<sup>b</sup>  
 זכור 3128<sup>b</sup>; 3129<sup>a</sup>  
 זכר 3128<sup>b</sup>; 3129<sup>a</sup>  
 זכר 522<sup>b</sup>; 1971<sup>b</sup>; 2557<sup>a</sup>;  
 3128<sup>a</sup>; 3134<sup>a</sup>  
 זכר 2030<sup>b</sup>; 2557<sup>a</sup>; 2701<sup>b</sup>;  
 זכר } 3140<sup>b</sup>  
 זכר  
 זכר 1106<sup>b</sup>; 1971<sup>b</sup>  
 זכרון 503<sup>b</sup>; 2030<sup>b</sup>; 2393<sup>a</sup>;  
 2538<sup>a</sup>  
 זכרי 3149<sup>a</sup>  
 זכריה } 3135<sup>a</sup>; 3136<sup>a</sup>  
 זכריה  
 זלל 1239<sup>b</sup>  
 זלעפה } 1423<sup>a</sup>  
 זלעפה  
 זלפה 3149<sup>b</sup>  
 זמה } 745<sup>b</sup>; 747<sup>a</sup>; 953<sup>a</sup>;  
 1880<sup>b</sup>; 3083<sup>b</sup>;  
 זמה } 3149<sup>b</sup>

זמורה }  
 זמרה } 513<sup>b</sup>; 2156<sup>a</sup>; 2818<sup>a</sup>  
 זמר }  
 זמזם 3132<sup>a</sup>  
 זמיר }  
 זמר } 3143<sup>a</sup>  
 זמרה }  
 זמירה }  
 זמם 896<sup>b</sup>; 1456<sup>a</sup>; 2972<sup>b</sup>  
 זמר 592<sup>b</sup>; 2429<sup>a</sup>  
 זמר 592<sup>b</sup>; 1249<sup>a</sup>; 3149<sup>b</sup>;  
 3155<sup>b</sup>; 3156<sup>a</sup>  
 זמר see זמיר  
 זמר see זמורה  
 זמרה 441<sup>b</sup>; 2029<sup>b</sup>  
 זמרה see זמיר  
 זמרה see זמורה  
 זמרי 3128<sup>b</sup>; 3149<sup>b</sup>; 3150<sup>a</sup>  
 זמרן 3149<sup>b</sup>  
 זנב 2903<sup>a</sup>  
 זנה 746<sup>b</sup>; 748<sup>b</sup>; 1339<sup>b</sup>;  
 1426<sup>a</sup>; 1470<sup>b</sup>;  
 2525<sup>b</sup>  
 זנית 3132<sup>a</sup>  
 זנין 1426<sup>a</sup>  
 זעה 2874<sup>b</sup>  
 זענן 3128<sup>a</sup>  
 זעה 1069<sup>a</sup>  
 זעם 819<sup>a</sup>  
 זעה 1145<sup>b</sup>  
 זעק 764<sup>b</sup>  
 זפה 242<sup>a</sup>; 2401<sup>b</sup>; 2817<sup>b</sup>  
 זק or זק see זיקה  
 זקן 71<sup>a</sup>; 130<sup>b</sup>; 131<sup>a</sup>;  
 418<sup>a</sup>; 923<sup>b</sup>; 1287<sup>a</sup>;  
 2183<sup>b</sup>; 2719<sup>b</sup>  
 זקן 71<sup>a</sup>  
 זקק 2044<sup>a</sup>; 2506<sup>b</sup>; 2545<sup>a</sup>  
 זר 762<sup>a, b</sup>  
 זרפבל 3147<sup>b</sup>  
 זרד 3132<sup>b</sup>; 3147<sup>a</sup>  
 זרה 1097<sup>b</sup>; 1456<sup>b</sup>; 2864<sup>b</sup>  
 זרוע }  
 זרע } 246<sup>b</sup>; 2780<sup>a, b</sup>  
 זרועה }  
 זרעה }  
 זרועה see זרוע  
 זרזר 868<sup>a</sup>  
 זרה 2773<sup>b</sup>

זרח 3146<sup>b</sup>  
 זרחי 3147<sup>a</sup>  
 זרחיה 3147<sup>a</sup>  
 זרם 1120<sup>a</sup>; 2781<sup>a</sup>; 2929<sup>b</sup>  
 זרמה 1542<sup>b</sup>  
 זרע 246<sup>b</sup>; 2501<sup>b</sup>  
 זרע 580<sup>a</sup>; 2712<sup>b</sup>; 2982<sup>b</sup>  
 זרע 2519<sup>b</sup>  
 זרע see זרוע  
 זרע } 1122<sup>a</sup>; 2501<sup>b</sup>  
 זרען }  
 זרעה see זרוע  
 זרק 2846<sup>b</sup>  
 זרר 762<sup>a</sup>; 2819<sup>b</sup>  
 זרש 3147<sup>a</sup>  
 זרה 2838<sup>b</sup>; 3079<sup>a</sup>  
 זריא 3133<sup>a</sup>  
 זרם 3148<sup>a</sup>  
 זרח 3148<sup>a</sup>  
 זר  
 זרב 504<sup>b</sup>  
 זרב 1402<sup>b</sup>  
 זרה 1586<sup>a</sup>  
 זרבלא 778<sup>a</sup>  
 זבור 599<sup>a</sup>; 1313<sup>b</sup>  
 זבירה }  
 זברה } 526<sup>b</sup>  
 זברה }  
 זביה } 1311<sup>a</sup>; 1402<sup>b</sup>  
 זבה }  
 זבל 2179<sup>b</sup>; 2408<sup>b</sup>; 3007<sup>b</sup>  
 זבל } 382<sup>a</sup>; 672<sup>a</sup>; 709<sup>b</sup>;  
 724<sup>a</sup>; 981<sup>b</sup>; 1344<sup>a</sup>;  
 זבל } 1894<sup>a</sup>; 2207<sup>a, b</sup>;  
 2422<sup>b</sup>; 2623<sup>b</sup>;  
 2836<sup>b</sup>  
 זבל 2408<sup>b</sup>  
 זבל } 2408<sup>b</sup>  
 זבלה }  
 זבל 421<sup>a</sup>; 2774<sup>b</sup>; 2775<sup>a</sup>  
 זבצלת 2623<sup>b</sup>; 2750<sup>b</sup>  
 זבצונה 1313<sup>a</sup>  
 זבק 1121<sup>a</sup>  
 זבסקוק 1311<sup>a</sup>  
 זכר 691<sup>a</sup>; 724<sup>b</sup>; 942<sup>b</sup>  
 זכר 691<sup>b</sup>; 942<sup>b</sup>; 1354<sup>b</sup>;  
 1964<sup>b</sup>; 2079<sup>a</sup>  
 זכר 1106<sup>a</sup>

**תְּבַרְבְּרָה** 2846<sup>b</sup>  
**תְּבַרְהָ** 1106<sup>a</sup>  
**תְּבַרְוֹן** 1365<sup>a</sup>; 1366<sup>b</sup>  
**תְּבַרְוֵי** } 1366<sup>b</sup>  
**תְּבַרְוֵי** }  
**תְּבַרִי** 1354<sup>b</sup>  
**תְּבַשׁ** 1349<sup>a</sup>; 2237<sup>a</sup>; 2658<sup>b</sup>  
**תְּבַת** 2237<sup>a</sup>  
**תְּג** { 1103<sup>a</sup>; 1123<sup>a</sup>; 1317<sup>a</sup>;  
 2257<sup>a</sup>; 2639<sup>a, b</sup>;  
**תְּג** { 2822<sup>a</sup>  
**תְּגַב** 1316<sup>a</sup>; 1907<sup>b</sup>; 1908<sup>a</sup>  
**תְּגַבָּא** } 1316<sup>a</sup>  
**תְּגַבָּה** }  
**תְּגַג** 587<sup>a</sup>; 1103<sup>a</sup>; 1405<sup>a</sup>;  
 2822<sup>a</sup>  
**תְּגוֹר** }  
**תְּגוֹר** } 254<sup>a</sup>  
**תְּגוֹרָה** }  
**תְּגָרָה** }  
**תְּגִי** 1319<sup>a</sup>  
**תְּגִי** 1317<sup>a</sup>  
**תְּגִיָּה** 1319<sup>a</sup>  
**תְּגִיָּת** 1319<sup>a</sup>  
**תְּדַר** 1313<sup>b</sup>  
**תְּדִי** 517<sup>b</sup>  
**תְּדִיר** 586<sup>a</sup>; 1315<sup>b</sup>  
**תְּדַל** 1126<sup>b</sup>  
**תְּדַל** 3108<sup>b</sup>  
**תְּדַלִי** 1315<sup>b</sup>  
**תְּדַק** 1366<sup>b</sup>; 2974<sup>a</sup>  
**תְּדַקְל** 1388<sup>b</sup>; 2981<sup>a</sup>  
**תְּדַר** 312<sup>b</sup>; 591<sup>b</sup>; 1455<sup>b</sup>;  
 1490<sup>b</sup>; 1998<sup>b</sup>  
**תְּדַרְדָּר** 1316<sup>a</sup>; 1421<sup>b</sup>  
**תְּדַשׁ** 1145<sup>b</sup>  
**תְּדַשׁ** 731<sup>a</sup>; 2140<sup>b</sup>  
**תְּדַשׁ** 303<sup>a</sup>; 1403<sup>a</sup>; 2081<sup>a</sup>;  
 2140<sup>b</sup>; 2811<sup>a</sup>;  
 2982<sup>a</sup>  
**תְּדַשָּׁה** 1314<sup>b</sup>  
**תְּדַת** 1314<sup>b</sup>  
**תְּדַבָּה** 1402<sup>b</sup>  
**תְּדַג** 314<sup>b</sup>; 656<sup>b</sup>; 694<sup>b</sup>  
**תְּדַה** 1266<sup>a</sup>  
**תְּדַה** 599<sup>a</sup>; 1040<sup>a</sup>; 1266<sup>a</sup>;  
 1345<sup>a</sup>; 3001<sup>a</sup>;  
 3049<sup>b</sup>; 3083<sup>b</sup>  
**תְּדוֹת יְאִיר** 411<sup>a</sup>; 1345<sup>a</sup>  
**תְּדוֹן** 1439<sup>a</sup>

**חֹתִם** 1419<sup>a</sup>; 1441<sup>a</sup>; 2972<sup>a</sup>;  
 2974<sup>a</sup>  
**חֹתִח** 2974<sup>b</sup>  
**חֹיט** 1110<sup>a</sup>  
**חֹי** 128<sup>a</sup>; 1402<sup>a</sup>  
**חֹיָה** 1345<sup>a</sup>  
**חֹיָל** } 136<sup>a</sup>; 522<sup>b</sup>; 1136<sup>a</sup>;  
**חֹיָל** } 2207<sup>a, b</sup>; 3007<sup>a, b</sup>  
**חֹיָל** 1439<sup>a</sup>  
**חֹיָל** 2458<sup>b</sup>; 2688<sup>b</sup>  
**חֹמָה** 1137<sup>a</sup>; 1140<sup>a</sup>  
**חֹס** 2402<sup>a</sup>  
**חֹהֶה** 672<sup>a</sup>; 1344<sup>b</sup>; 2779<sup>b</sup>  
**חֹפֶסֶם** 1441<sup>b</sup>  
**חֹיָץ** } 23<sup>a</sup>; 1136<sup>b</sup>; 1446<sup>b</sup>;  
**חֹיָץ** } 1811<sup>a</sup>  
**חֹר** } 340<sup>a</sup>; 676<sup>a</sup>; 1441<sup>b</sup>  
**חֹר** }  
**חֹר** } 585<sup>a</sup>  
**חֹר** }  
**חֹרְוֹן** see **חֹרְוֹן בֵּית**  
**חֹרִי** see **חֹרִי**  
**חֹרִי** 676<sup>a</sup>; 1442<sup>a</sup>  
**חֹרִי** 1388<sup>b</sup>; 1442<sup>a</sup>  
**חֹרְסִים** 1394<sup>b</sup>; 1442<sup>a</sup>  
**חֹרְוֹן** 1344<sup>a</sup>  
**חֹשׁ** 1343<sup>a</sup>  
**חֹשָׁה** 1443<sup>a</sup>  
**חֹשִׁי** 1443<sup>a</sup>  
**חֹשִׁים** }  
**חֹשִׁים** } 1443<sup>a</sup>  
**חֹשֶׁם** }  
**חֹשֶׁם** } 1443<sup>a</sup>  
**חֹשֶׁם** }  
**חֹתָם** } 1434<sup>a</sup>; 2594<sup>b</sup>; 2708<sup>a</sup>  
**חֹתָם** }  
**חֹתָל** } 1345<sup>b</sup>  
**חֹתָל** }  
**חֹזָה** 2156<sup>a</sup>; 2411<sup>a</sup>; 2581<sup>a</sup>;  
 2712<sup>b</sup>  
**חֹזָה** 517<sup>b</sup>  
**חֹזָה** 631<sup>b</sup>; 674<sup>a</sup>; 783<sup>b</sup>;  
 1152<sup>a</sup>; 1439<sup>a</sup>;  
 1447<sup>b</sup>; 2581<sup>a</sup>;  
 2713<sup>a</sup>  
**חֹזָל** see **חֹזָל**  
**חֹזִל** 1347<sup>b</sup>  
**חֹזֹן** 2581<sup>a, b</sup>; 3057<sup>b</sup>  
**חֹזִית** 2156<sup>a</sup>; 2581<sup>a</sup>  
**חֹזִיָּל** 1347<sup>b</sup>

**חֹזִיָּה** 1346<sup>b</sup>  
**חֹזִיָּו** 1388<sup>b</sup>; 2588<sup>b</sup>  
**חֹזִיָּו** 2581<sup>a</sup>; 3045<sup>b</sup>; 3057<sup>b</sup>  
**חֹזִיָּה** 1892<sup>b</sup>  
**חֹזִיר** 491<sup>a</sup>; 1339<sup>a</sup>; 2875<sup>b</sup>  
**חֹזִיר** 1388<sup>b</sup>  
**חֹזִק** 88<sup>a</sup>; 704<sup>b</sup>; 724<sup>b</sup>;  
 747<sup>b</sup>; 1337<sup>b</sup>;  
 1338<sup>a</sup>; 2558<sup>a</sup>;  
 2569<sup>b</sup>; 2871<sup>b</sup>;  
 3045<sup>b</sup>  
**חֹזִקִי** 1402<sup>a</sup>  
**חֹזִקָּה** }  
**חֹזִקָּה** } 1385<sup>a</sup>; 1402<sup>a</sup>  
**חֹזִקָּה** }  
**חֹזִקָּה** }  
**חֹח** } 512<sup>b</sup>; 513<sup>a</sup>; 523<sup>b</sup>;  
**חֹחִי** } 1419<sup>a</sup>; 1441<sup>a</sup>  
**חֹטָא** 321<sup>a, b</sup>; 668<sup>a</sup>; 1101<sup>b</sup>;  
 1929<sup>b</sup>; 2179<sup>b</sup>;  
 2506<sup>b</sup>  
**חֹטָא** 1101<sup>b</sup>; 1306<sup>b</sup>  
**חֹטָא** 2179<sup>b</sup>; 2806<sup>a</sup>  
**חֹטָאָה** 2639<sup>a</sup>  
**חֹטָאָה** } 1069<sup>a</sup>; 2020<sup>a</sup>; 2504<sup>b</sup>;  
 2639<sup>a</sup>; 2642<sup>b</sup>;  
**חֹטָאָה** } 2798<sup>b</sup>  
**חֹטָב** 1384<sup>b</sup>  
**חֹטָבָה** 581<sup>b</sup>  
**חֹטָה** 1122<sup>a</sup>; 1789<sup>a</sup>; 3082<sup>b</sup>  
**חֹטָשׁ** 1343<sup>b</sup>  
**חֹטָשָׁא** 1343<sup>b</sup>  
**חֹטָשָׁל** 1343<sup>b</sup>  
**חֹטָשָׁא** 1343<sup>b</sup>  
**חֹי** 97<sup>a</sup>; 145<sup>b</sup>; 208<sup>b</sup>;  
 418<sup>b</sup>; 503<sup>a</sup>; 604<sup>a</sup>;  
 739<sup>a</sup>; 1888<sup>a</sup>;  
 1889<sup>a</sup>; 1905<sup>b</sup>;  
 1906<sup>a</sup>; 2189<sup>a</sup>;  
 2495<sup>a</sup>; 3009<sup>a</sup>;  
 3084<sup>a</sup>  
**חֹנָא** } 1266<sup>a</sup>  
**חֹנָה** }  
**חֹנָל** 1389<sup>a</sup>  
**חֹנָה** 789<sup>a</sup>; 1170<sup>b</sup>; 1171<sup>a</sup>;  
 1337<sup>b</sup>; 2469<sup>b</sup>;  
 2471<sup>a</sup>; 2515<sup>a</sup>;  
 2591<sup>a</sup>  
**חֹנָה** 418<sup>b</sup>; 421<sup>b</sup>; 1888<sup>a</sup>;  
 2515<sup>a</sup>; 2538<sup>b</sup>;  
 2558<sup>a</sup>; 2587<sup>b</sup>  
**חֹנָה** 1905<sup>b</sup>  
**חֹיָל** } 176<sup>a</sup>; 528<sup>a</sup>; 1137<sup>a</sup>;  
**חֹל** } 1140<sup>a</sup>; 2930<sup>a</sup>;  
 2937<sup>b</sup>

חורל see חורל  
 חורל 382<sup>a</sup>; 491<sup>a</sup>; 1127<sup>a</sup>;  
 1279<sup>a</sup>; 2590<sup>b</sup>;  
 3005<sup>a</sup>; 3045<sup>b</sup>;  
 3057<sup>b</sup>; 3076<sup>a</sup>  
 חורלה 528<sup>a</sup>  
 חורלם } 1370<sup>a</sup>  
 חורלם  
 חורלם } 1370<sup>a</sup>  
 חורלם  
 חורלם } 1392<sup>a</sup>  
 חורלם  
 חורלם } 182<sup>b</sup>; 554<sup>b</sup>  
 חורלם  
 חורלם } 504<sup>b</sup>; 510<sup>b</sup>; 511<sup>a</sup>;  
 חורלם } 1839<sup>a</sup>  
 חורלם  
 חורלם } 1394<sup>b</sup>  
 חורלם  
 חורלם } 1394<sup>b</sup>  
 חורלם  
 חורלם } 2093<sup>a</sup>; 2917<sup>b</sup>  
 חורלם  
 חורלם } 1116<sup>a</sup>; 1419<sup>a</sup>  
 חורלם  
 חורלם } 1313<sup>b</sup>  
 חורלם  
 חורלם } 1313<sup>b</sup>  
 חורלם  
 חורלם } 676<sup>a</sup>  
 חורלם  
 חורלם } 2813<sup>b</sup>; 3089<sup>a</sup>  
 חורלם  
 חורלם } 336<sup>a</sup>; 765<sup>b</sup>; 766<sup>a</sup>;  
 חורלם } 783<sup>b</sup>; 789<sup>b</sup>; 2868<sup>a</sup>;  
 חורלם } 3089<sup>a</sup>; 3098<sup>a</sup>  
 חורלם  
 חורלם } 1124<sup>b</sup>; 1541<sup>a</sup>; 2191<sup>a</sup>;  
 חורלם } 2471<sup>a</sup>; 2474<sup>b</sup>;  
 חורלם } 3089<sup>a</sup>; 3097<sup>a</sup>  
 חורלם  
 חורלם } 1313<sup>b</sup>  
 חורלם  
 חורלם } see חורל  
 חורלם  
 חורלם } see חורל  
 חורלם  
 חורלם } 1369<sup>b</sup>; 2627<sup>a</sup>; 2706<sup>a</sup>  
 חורלם  
 חורלם } 441<sup>b</sup>; 1099<sup>b</sup>; 1101<sup>b</sup>;  
 חורלם } 1110<sup>b</sup>; 1294<sup>a</sup>;  
 חורלם } 1370<sup>a</sup>; 1999<sup>b</sup>  
 חורלם  
 חורלם } 1123<sup>b</sup>; 2051<sup>b</sup>  
 חורלם  
 חורלם } 1370<sup>a</sup>  
 חורלם  
 חורלם } 1370<sup>a</sup>  
 חורלם  
 חורלם } 1163<sup>a</sup>  
 חורלם  
 חורלם } 71<sup>a</sup>; 3108<sup>b</sup>  
 חורלם  
 חורלם } 1370<sup>a</sup>  
 חורלם  
 חורלם } 1106<sup>b</sup>; 1906<sup>a</sup>; 1907<sup>b</sup>;  
 חורלם } 2074<sup>a</sup>; 3076<sup>b</sup>  
 חורלם  
 חורלם } 1439<sup>a</sup>  
 חורלם  
 חורלם } 1370<sup>a</sup>  
 חורלם  
 חורלם } 578<sup>a</sup>; 854<sup>a</sup>; 1305<sup>b</sup>;  
 חורלם } 1306<sup>a</sup>; 1468<sup>a</sup>;  
 חורלם } 1675<sup>b</sup>; 2207<sup>a, b</sup>;  
 חורלם } 2783<sup>a</sup>  
 חורלם  
 חורלם } 517<sup>a</sup>  
 חורלם  
 חורלם } 874<sup>a</sup>  
 חורלם

חורלם } 1405<sup>a</sup>  
 חורלם  
 חורלם } 1437<sup>a</sup>; 2412<sup>a</sup>  
 חורלם  
 חורלם } 1321<sup>b</sup>  
 חורלם  
 חורלם } 854<sup>a</sup>; 1305<sup>b</sup>; 1306<sup>a</sup>;  
 חורלם } 2783<sup>a</sup>  
 חורלם  
 חורלם } 2095<sup>a</sup>; 2097<sup>a</sup>  
 חורלם  
 חורלם } 1097<sup>b</sup>; 1127<sup>a</sup>  
 חורלם  
 חורלם } 426<sup>a</sup>; 485<sup>a</sup>; 517<sup>b</sup>;  
 חורלם } 747<sup>b</sup>; 818<sup>a</sup>; 2458<sup>b</sup>;  
 חורלם } 3036<sup>a</sup>  
 חורלם  
 חורלם } 2458<sup>b</sup>  
 חורלם  
 חורלם } see חורלם  
 חורלם  
 חורלם } 874<sup>a</sup>; 1370<sup>a</sup>  
 חורלם  
 חורלם } 1119<sup>b</sup>; 2596<sup>a</sup>  
 חורלם  
 חורלם } 1374<sup>a</sup>  
 חורלם  
 חורלם } 593<sup>b</sup>  
 חורלם  
 חורלם } 1370<sup>a</sup>  
 חורלם  
 חורלם } 1942<sup>a</sup>; 2553<sup>b</sup>  
 חורלם  
 חורלם } 1370<sup>b</sup>  
 חורלם  
 חורלם } 1797<sup>b</sup>; 1917<sup>a, b</sup>  
 חורלם  
 חורלם } 860<sup>a</sup>; 2422<sup>b</sup>  
 חורלם  
 חורלם } 1468<sup>b</sup>; 2422<sup>b</sup>  
 חורלם  
 חורלם } 1322<sup>a</sup>  
 חורלם  
 חורלם } 1307<sup>a</sup>; 2247<sup>b</sup>  
 חורלם  
 חורלם } 1370<sup>b</sup>  
 חורלם  
 חורלם } 1370<sup>b</sup>; 1392<sup>a</sup>  
 חורלם  
 חורלם } 1370<sup>b</sup>  
 חורלם  
 חורלם } 1370<sup>b</sup>  
 חורלם  
 חורלם } 128<sup>a</sup>; 1323<sup>b</sup>; 2069<sup>b</sup>;  
 חורלם } 2556<sup>a</sup>  
 חורלם  
 חורלם } 68<sup>b</sup>; 1352<sup>a</sup>  
 חורלם  
 חורלם } see חורלם  
 חורלם  
 חורלם } 1123<sup>b</sup>; 2052<sup>a</sup>  
 חורלם  
 חורלם } 433<sup>a</sup>; 820<sup>a</sup>; 1941<sup>b</sup>;  
 חורלם } 1942<sup>a</sup>  
 חורלם  
 חורלם } 832<sup>b</sup>; 2534<sup>b</sup>; 3074<sup>a</sup>  
 חורלם  
 חורלם } 1374<sup>b</sup>  
 חורלם  
 חורלם } 2415<sup>b</sup>; 2418<sup>a</sup>  
 חורלם  
 חורלם } 301<sup>b</sup>  
 חורלם  
 חורלם } 1326<sup>a</sup>  
 חורלם  
 חורלם } 1332<sup>b</sup>  
 חורלם  
 חורלם } 1452<sup>a</sup>  
 חורלם

חורלם } 287<sup>a</sup>; 678<sup>b</sup>; 941<sup>b</sup>;  
 חורלם } 1332<sup>b</sup>; 1350<sup>b</sup>;  
 חורלם } 2052<sup>b</sup>  
 חורלם  
 חורלם } 2556<sup>a</sup>  
 חורלם  
 חורלם } 1106<sup>b</sup>; 1906<sup>a</sup>; 1907<sup>a</sup>;  
 חורלם } 2688<sup>b</sup>; 2819<sup>a</sup>  
 חורלם  
 חורלם } 1430<sup>a</sup>  
 חורלם  
 חורלם } 667<sup>b</sup>  
 חורלם  
 חורלם } 695<sup>a</sup>; 2402<sup>a</sup>  
 חורלם  
 חורלם } 2402<sup>a</sup>  
 חורלם  
 חורלם } 1324<sup>a</sup>  
 חורלם  
 חורלם } 1454<sup>b</sup>; 1533<sup>b</sup>; 2527<sup>b</sup>  
 חורלם  
 חורלם } 3051<sup>a</sup>  
 חורלם  
 חורלם } 763<sup>b</sup>; 778<sup>a</sup>  
 חורלם  
 חורלם } 883<sup>b</sup>; 1122<sup>a</sup>; 1306<sup>a</sup>;  
 חורלם } 1832<sup>a</sup>; 2469<sup>b</sup>  
 חורלם  
 חורלם } 3051<sup>a</sup>; 3087<sup>a</sup>  
 חורלם  
 חורלם } 287<sup>a</sup>; 676<sup>a</sup>; 1141<sup>b</sup>  
 חורלם  
 חורלם } 3086<sup>b</sup>  
 חורלם  
 חורלם } 3086<sup>b</sup>  
 חורלם  
 חורלם } see חורלם  
 חורלם  
 חורלם } 667<sup>a</sup>; 1350<sup>b</sup>; 1418<sup>a</sup>;  
 חורלם } 2000<sup>a</sup>; 2817<sup>b</sup>;  
 חורלם } 3080<sup>a</sup>  
 חורלם  
 חורלם } 242<sup>a</sup>; 667<sup>a</sup>; 2401<sup>b</sup>;  
 חורלם } 2817<sup>b</sup>  
 חורלם  
 חורלם } 126<sup>a</sup>; 1374<sup>b</sup>  
 חורלם  
 חורלם } 1117<sup>b</sup>  
 חורלם  
 חורלם } 2590<sup>a</sup>  
 חורלם  
 חורלם } 255<sup>a</sup>; 1340<sup>b</sup>; 2590<sup>a</sup>  
 חורלם  
 חורלם } see חורלם  
 חורלם  
 חורלם } 509<sup>b</sup>; 2814<sup>a</sup>; 3088<sup>a</sup>  
 חורלם  
 חורלם } 1324<sup>b</sup>  
 חורלם  
 חורלם } see חורלם  
 חורלם  
 חורלם } 941<sup>a</sup>; 1325<sup>a</sup>  
 חורלם  
 חורלם } 1326<sup>a</sup>  
 חורלם  
 חורלם } 127<sup>b</sup>; 1102<sup>a</sup>; 1292<sup>a</sup>;  
 חורלם } 1374<sup>b</sup>  
 חורלם  
 חורלם } 1374<sup>b</sup>  
 חורלם  
 חורלם } 2948<sup>b</sup>  
 חורלם  
 חורלם } 136<sup>b</sup>; 1336<sup>a</sup>  
 חורלם  
 חורלם } 953<sup>a</sup>; 1336<sup>a</sup>; 1374<sup>b</sup>  
 חורלם  
 חורלם } 1336<sup>b</sup>  
 חורלם  
 חורלם } 536<sup>a</sup>  
 חורלם  
 חורלם } 940<sup>a</sup>  
 חורלם  
 חורלם } 1336<sup>a</sup>  
 חורלם  
 חורלם } 252<sup>a, b</sup>  
 חורלם  
 חורלם } 3005<sup>a</sup>

**הַנְּקָא** 1617<sup>b</sup>  
**הַנְּקָה** 816<sup>b</sup>; 1951<sup>a</sup>; 1952<sup>a</sup>;  
 1953<sup>a</sup>  
**הַנְּקָם** 1145<sup>a</sup>; 1471<sup>a</sup>; 2156<sup>b</sup>;  
 3063<sup>a</sup>  
**הַנְּמָאָל** 1332<sup>b</sup>  
**הַנְּמָל** 1147<sup>a, b</sup>  
**הַנְּן** 1292<sup>b</sup>; 1490<sup>b</sup>; 2035<sup>b</sup>;  
 2402<sup>a</sup>  
**הַנְּן** 137<sup>a</sup>; 1333<sup>a</sup>  
**הַנְּנָאָל** 1333<sup>a</sup>  
**הַנְּנִי** 1333<sup>a</sup>  
**הַנְּנִיָּה** } 129<sup>a</sup>; 1333<sup>a</sup>  
**הַנְּנִיָּהָ** }  
**הַנְּס** 1335<sup>b</sup>  
**הַנְּה** 818<sup>a</sup>; 1270<sup>a</sup>; 1445<sup>a, b</sup>;  
 3036<sup>a</sup>  
**הַנְּפָה** 2458<sup>b</sup>  
**הַנְּק** 1107<sup>a</sup>; 2866<sup>a</sup>  
**הַנְּתָן** 1336<sup>a</sup>  
**הַסָּד** 1934<sup>a</sup>  
**הַסָּד** 747<sup>a</sup>; 1278<sup>a</sup>; 1279<sup>a</sup>;  
 1292<sup>a</sup>; 1781<sup>b</sup>;  
 1799<sup>a</sup>; 1934<sup>a, b</sup>;  
 2035<sup>b</sup>; 2402<sup>a</sup>;  
 2555<sup>a</sup>  
**הַסָּדִיָּה** 1342<sup>a</sup>  
**הַסָּה** 1424<sup>a</sup>  
**הַסִּיד** 1002<sup>a</sup>; 1270<sup>a</sup>; 1428<sup>a</sup>;  
 1527<sup>b</sup>; 1540<sup>b</sup>;  
 2044<sup>a</sup>; 2658<sup>b</sup>;  
 2659<sup>b</sup>; 2661<sup>b</sup>  
**הַסִּידָה** 2863<sup>a, b</sup>  
**הַסִּיל** 583<sup>a</sup>; 1473<sup>a</sup>; 1907<sup>b</sup>;  
 1908<sup>b</sup>  
**הַסִּל** 1907<sup>b</sup>; 1908<sup>b</sup>  
**הַסָּם** 2102<sup>a</sup>  
**הַסָּן** 2422<sup>b</sup>  
**הַסָּן** 2590<sup>b</sup>; 3007<sup>b</sup>; 3008<sup>a</sup>  
**הַסָּה** 667<sup>a</sup>  
**הַסָּר** 439<sup>b</sup>; 1821<sup>a</sup>  
**הַסָּרָה** 1342<sup>b</sup>  
**הַסָּרֹן** 896<sup>b</sup>  
**הַסָּ** 1471<sup>a</sup>  
**הַסָּה** 587<sup>a</sup>; 669<sup>b</sup>  
**הַסָּה** 566<sup>a</sup>; 591<sup>b</sup>; 669<sup>b</sup>;  
 1441<sup>b</sup>; 1998<sup>b</sup>  
**הַסָּזֹן** 1343<sup>a</sup>  
**הַסָּים** 1441<sup>b</sup>  
**הַסָּן** 1334<sup>b</sup>  
**הַסָּנִי** 1421<sup>a</sup>  
**הַסָּה** 1344<sup>b</sup>

**הַסָּן** 820<sup>a</sup>; 1343<sup>a</sup>; 3096<sup>b</sup>  
**הַסָּן** 27<sup>b</sup>; 820<sup>b</sup>; 2408<sup>b</sup>;  
 2811<sup>b</sup>  
**הַסָּרָה** 1375<sup>a</sup>  
**הַסָּר** 2074<sup>a</sup>; 2293<sup>a</sup>  
**הַסָּר** 267<sup>a</sup>; 700<sup>b</sup>  
**הַסָּר** 1375<sup>a</sup>  
**הַסָּרִי** 1375<sup>a</sup>  
**הַסָּרִים** 1336<sup>b</sup>  
**הַסָּש** 1389<sup>a</sup>  
**הַסָּשִׁית** } 2744<sup>b</sup>  
**הַסָּשִׁית** }  
**הַסָּן** 252<sup>a</sup>; 789<sup>b</sup>; 1293<sup>b</sup>;  
 2746<sup>b</sup>  
**הַסָּן** see הַסָּן  
**הַסָּב** } 1385<sup>a</sup>; 2007<sup>a</sup>  
**הַסָּב** }  
**הַסָּזֹר** 1347<sup>b</sup>  
**הַסָּזֹר תַּדְּתָה** 1347<sup>b</sup>  
**הַסָּזֹת** 2050<sup>a</sup>  
**הַסָּזִי** 2050<sup>a</sup>; 2078<sup>b</sup>  
**הַסָּזִי הַמְּנָחֹת** } 1343<sup>b</sup>  
**הַסָּזִי הַמְּנָחֹתֵי** }  
**הַסָּזִיר** 1122<sup>a</sup>; 1293<sup>a</sup>; 1375<sup>a</sup>;  
 1864<sup>b</sup>  
**הַסָּזִן** 504<sup>b</sup>; 1839<sup>a</sup>  
**הַסָּזִן** 246<sup>b</sup>; 1839<sup>a, b</sup>  
**הַסָּזִן** 382<sup>a</sup>; 1293<sup>b</sup>  
**הַסָּזִן** 1293<sup>b</sup>  
**הַסָּזִן תַּמָּר** } 1347<sup>a, b</sup>  
**הַסָּזִן תַּמָּר** }  
**הַסָּזִרָה** 305<sup>a</sup>; 1103<sup>a</sup>; 2095<sup>a</sup>;  
 2097<sup>a</sup>  
**הַסָּזִר** } 1346<sup>b</sup>  
**הַסָּזִר** }  
**הַסָּזִר** 725<sup>a</sup>; 1346<sup>b</sup>; 2889<sup>a</sup>;  
 2932<sup>b</sup>; 2933<sup>a</sup>;  
 3001<sup>a</sup>; 3049<sup>b</sup>  
**הַסָּזִרָה** 1346<sup>b</sup>  
**הַסָּזִר גָּדָה** 1347<sup>a</sup>  
**הַסָּזִר הַתִּיכּוֹן** 1347<sup>a</sup>  
**הַסָּזִר** 1388<sup>b</sup>  
**הַסָּזִרֹן** 1388<sup>b</sup>; 1793<sup>a, b</sup>  
**הַסָּזִרִי** 1388<sup>b</sup>  
**הַסָּזִרֹת** 1347<sup>b</sup>; 1811<sup>a</sup>  
**הַסָּזִרים** 340<sup>b</sup>; 1347<sup>a</sup>; 1790<sup>a</sup>  
**הַסָּזִרֹת** 1347<sup>a</sup>  
**הַסָּזִר סוּסָה** 1347<sup>a</sup>  
**הַסָּזִר עֵינָן** 1346<sup>b</sup>

**הַסָּזִר שׁוּעָל** 1347<sup>a</sup>  
**הַסָּן** see הַסָּן  
**הַסָּן** 706<sup>a</sup>; 769<sup>b</sup>; 883<sup>b</sup>;  
 1852<sup>a, b</sup>; 2016<sup>a</sup>;  
 2201<sup>a</sup>  
**הַסָּה** 581<sup>b</sup>  
**הַסָּה** 769<sup>b</sup>; 2201<sup>a</sup>  
**הַסָּפָא** 1321<sup>b</sup>  
**הַסָּן** 1289<sup>b</sup>; 1858<sup>b</sup>; 2156<sup>b</sup>;  
 2702<sup>a</sup>; 2743<sup>a</sup>;  
 3119<sup>a</sup>  
**הַסָּן** 2710<sup>a</sup>  
**הַסָּן** } 1370<sup>b</sup>; 1439<sup>a</sup>  
**הַסָּן** }  
**הַסָּן** 2710<sup>a</sup>  
**הַסָּן** 2710<sup>a</sup>  
**הַסָּר** see הַסָּר  
**הַסָּר** see הַסָּר  
**הַסָּרָה** } see הַסָּר  
**הַסָּרִי** }  
**הַסָּרִב** 252<sup>b</sup>; 341<sup>b</sup>; 1815<sup>b</sup>;  
 2012<sup>b</sup>  
**הַסָּרִב** 815<sup>a</sup>; 833<sup>a</sup>  
**הַסָּרִב** 1352<sup>a</sup>  
**הַסָּרִבָּה** 831<sup>b</sup>  
**הַסָּרִבָּה** } 1337<sup>b</sup>  
**הַסָּרִבָּה** }  
**הַסָּרִגָּל** 425<sup>a</sup>; 745<sup>b</sup>; 1473<sup>a</sup>;  
 1907<sup>b</sup>; 1908<sup>a</sup>  
**הַסָּרִר** 1145<sup>a</sup>  
**הַסָּרִרָה** 577<sup>b</sup>; 1337<sup>a</sup>  
**הַסָּרִרִי** 1340<sup>b</sup>  
**הַסָּרִרָה** 669<sup>b</sup>; 1145<sup>b</sup>; 1306<sup>a</sup>  
**הַסָּרִרָה** 1339<sup>a</sup>  
**הַסָּרִרָל** } 2140<sup>a</sup>  
**הַסָּרִרָל** }  
**הַסָּרִרֹן** see הַסָּרִרֹן  
**הַסָּרִרָה** 1341<sup>b</sup>  
**הַסָּרִרָה** 1341<sup>b</sup>  
**הַסָּרִרָן** 1111<sup>a</sup>; 1274<sup>a</sup>; 1341<sup>b</sup>;  
 1967<sup>b</sup>; 2976<sup>a</sup>  
**הַסָּרִרָר** 1339<sup>a</sup>  
**הַסָּרִרָס** 1339<sup>a</sup>  
**הַסָּרִרָר** 1108<sup>b</sup>  
**הַסָּרִרָט** 3119<sup>a</sup>  
**הַסָּרִרָט** 2297<sup>b</sup>  
**הַסָּרִרָט** see הַסָּרִרָט  
**הַסָּרִרָטָם** 1568<sup>a</sup>; 3125<sup>b</sup>  
**הַסָּרִרָרִי** see הַסָּרִרָרִי



חַרִּי	128 <sup>a</sup> ; 1421 <sup>b</sup> ; 2154 <sup>a</sup> ;	חֲרָשׁ	1376 <sup>b</sup>	חַתִּית	2949 <sup>b</sup>
חֹרֵר	2974 <sup>b</sup>	חֲרַשׁ	811 <sup>a</sup>	חֲתַל	2874 <sup>a</sup>
חֲרִישׁ	} 377 <sup>b</sup> ; 748 <sup>b</sup>	חֲרָשׁ	1132 <sup>a</sup> ; 1507 <sup>b</sup> ; 2781 <sup>a</sup>	חֲתַלָּה	2874 <sup>a</sup>
חֲרַט		חֲרַשׁ	1421 <sup>b</sup>	חֲתַלֵּן	1384 <sup>b</sup>
חֲרִי-יֹדֵקִים	} 872 <sup>b</sup>	חֲרָשׁ	580 <sup>a, b</sup> ; 1968 <sup>b</sup> ;	חֲתָם	427 <sup>a</sup> ; 430 <sup>a</sup> ; 943 <sup>a</sup> ;
חֲרַאִיֹּן		3105 <sup>b</sup>	חֲרָשָׁא	1341 <sup>a</sup>	חֲתָם
חֲרִיָּה	1339 <sup>b</sup>	חֲרָשִׁים	594 <sup>a</sup> ; 1909 <sup>a</sup>	חֲתָם	see חֲתָם
חֲרִיץ	} 1123 <sup>b</sup> ; 1341 <sup>a</sup> ; 2052 <sup>a</sup>	חֲרָשָׁת	581 <sup>b</sup> ; 769 <sup>b</sup> ; 1341 <sup>a</sup>	חֲתָן	66 <sup>a</sup> ; 1674 <sup>b</sup> ; 2525 <sup>a</sup> ;
חֲרָץ		חֲרָת	1339 <sup>a</sup> ; 1377 <sup>a</sup>	2556 <sup>a</sup>	חֲתָר
חֲרִישׁ	886 <sup>b</sup> ; 1307 <sup>a</sup>	חֲשַׁב	765 <sup>b</sup> ; 766 <sup>a</sup> ; 840 <sup>a</sup> ;	חֲתַת	15 <sup>a</sup> ; 523 <sup>a</sup> ; 594 <sup>a</sup> ;
חֲרִישֵׁי	3046 <sup>b</sup>		940 <sup>a</sup> ; 1005 <sup>b</sup> ;	חֲתַת	700 <sup>b</sup>
חֲרָף	1437 <sup>a</sup>		1127 <sup>b</sup> ; 1456 <sup>a</sup> ;	חֲתַת	1343 <sup>b</sup>
חֲרַל	see חֲרוּל		1462 <sup>b</sup> ; 2813 <sup>b</sup> ;		
חֲרָם	1117 <sup>b</sup> ; 1132 <sup>a</sup> ; 1341 <sup>a</sup>	חֲשַׁב	2972 <sup>b</sup> ; 2975 <sup>a</sup>	ט	
חֲרָם	} 15 <sup>b</sup> ; 34 <sup>b</sup> ; 130 <sup>a</sup> ; 767 <sup>b</sup> ;	חֲשַׁבְתָּה	767 <sup>a</sup>	טָב	1110 <sup>b</sup>
חֲרָם		816 <sup>b</sup> ; 840 <sup>a</sup> ; 1050 <sup>b</sup> ;	חֲשַׁבְתָּה	1342 <sup>a</sup>	טָבֵאל
חֲרָם	1256 <sup>a</sup>	חֲשַׁבְתָּה	1342 <sup>b</sup>	טָבֵאל	2887 <sup>b</sup>
חֲרָם	1115 <sup>a</sup> ; 1421 <sup>b</sup>	חֲשַׁבְתָּן	1384 <sup>a</sup>	טָבוּל	883 <sup>b</sup>
חֲרָם	1339 <sup>a</sup> ; 2553 <sup>a</sup>	חֲשַׁבְתָּה	} 1342 <sup>a</sup>	טָבַח	418 <sup>b</sup>
חֲרַמָּה	1422 <sup>a</sup>	חֲשַׁבְתָּה		חֲשַׁבְתָּה	טָבַח
חֲרַמוֹן	1378 <sup>a</sup>	חֲשַׁבְתָּה	1342 <sup>a</sup>	טָבַח	1307 <sup>b</sup>
חֲרַמוֹנִים	1378 <sup>a</sup>	חֲשַׁבְתָּה	1342 <sup>a</sup>	טָבַחַת	1118 <sup>b</sup>
חֲרַמֵּשׁ	2784 <sup>a</sup>	חֲשַׁבְתָּה	2293 <sup>b</sup>	טָבַחַת	2980 <sup>a</sup>
חֲרָן	1337 <sup>a</sup>	חֲשַׁבְתָּה	1342 <sup>b</sup>	טָבַל	851 <sup>a</sup>
חֲרָן	see חֲרוֹן	חֲשַׁבְתָּה	see חֲשַׁבְתָּה	טָבַלְתָּה	2924 <sup>a</sup>
חֲרָנִי	1423 <sup>a</sup>	חֲשַׁבְתָּה	1126 <sup>b</sup>	טָבַע	2594 <sup>a</sup> ; 2743 <sup>b</sup>
חֲרָנִים	1423 <sup>a</sup>	חֲשַׁבְתָּה	789 <sup>a</sup> ; 2177 <sup>b</sup>	טָבַעַת	2887 <sup>a</sup>
חֲרָקָר	1340 <sup>b</sup>	חֲשַׁבְתָּה	2016 <sup>a</sup>	טָבַעַת	2594 <sup>a</sup> ; 2708 <sup>a</sup>
חֲרָם	} 301 <sup>b</sup> ; 452 <sup>b</sup> ; 665 <sup>b</sup> ;	חֲשַׁבְתָּה	1342 <sup>b</sup>	טָבַרְמוֹן	2902 <sup>a</sup>
חֲרָם		1341 <sup>a</sup> ; 1376 <sup>b</sup> ;	חֲשַׁבְתָּה	see חֲשַׁבְתָּה	טָבַרְתָּה
חֲרָסָה	1491 <sup>a</sup> ; 2193 <sup>a</sup> ;	חֲשַׁבְתָּה	see חֲשַׁבְתָּה	טָבַרְתָּה	2887 <sup>b</sup>
חֲרָסָה	2856 <sup>a</sup>	חֲשַׁבְתָּה	584 <sup>a</sup>	טָהוֹר	} 1087 <sup>b</sup> ; 2506 <sup>b</sup>
חֲרָס	1543 <sup>a</sup> ; 2423 <sup>b</sup> ; 2425 <sup>b</sup>	חֲשַׁבְתָּה	1384 <sup>b</sup>	טָהוֹר	
חֲרַסִּית	} 1341 <sup>a</sup>	חֲשַׁבְתָּה	927 <sup>b</sup> ; 2044 <sup>a</sup> ; 2859 <sup>a</sup> ;	טָהַר	667 <sup>a, b</sup> ; 668 <sup>a</sup> ; 2506 <sup>b</sup>
חֲרַסִּית		חֲרָה	2860 <sup>a</sup>	חֲשַׁמֵּן	טָהַר
חֲרָה	485 <sup>b</sup> ; 819 <sup>a</sup> ; 2525 <sup>b</sup> ;	חֲרָה	2454 <sup>b</sup>	חֲשַׁן	1110 <sup>b</sup> ; 1277 <sup>a</sup> ;
חֲרָה	3089 <sup>a</sup>	חֲרָה	1342 <sup>a</sup>	חֲשַׁן	1278 <sup>b</sup> ; 1279 <sup>a</sup> ;
חֲרָה	2710 <sup>b</sup> ; 2982 <sup>b</sup> ; 3089 <sup>a</sup>	חֲרָה	517 <sup>b</sup> ; 518 <sup>a</sup> ; 1060 <sup>a</sup> ;	חֲשַׁה	1799 <sup>a</sup> ; 2990 <sup>a, b</sup>
חֲרָה	1339 <sup>a</sup>	חֲרָה	2442 <sup>a</sup> ; 3041 <sup>a</sup>	חֲשַׁה	1087 <sup>b</sup> ; 1277 <sup>a, b</sup> ;
חֲרָץ	834 <sup>a</sup> ; 1917 <sup>a</sup>	חֲרָה	584 <sup>a</sup> ; 852 <sup>a</sup>	חֲשַׁה	1279 <sup>a</sup>
חֲרָץ	see חֲרַיֵּץ	חֲרָה	} 1110 <sup>a</sup>	חֲשַׁה	
חֲרַצָּה	382 <sup>a</sup>	חֲרָה		חֲשַׁק	חֲשַׁה
חֲרָץ	see חֲרַיֵּץ	חֲרָה	חֲשַׁק	חֲשַׁה	} 2924 <sup>a</sup> ; 2990 <sup>a, b</sup>
חֲרַצָּן	1793 <sup>b</sup> ; 3050 <sup>a</sup>	חֲרָה	חֲשַׁק	חֲשַׁה	
חֲרַק	1239 <sup>b</sup>	חֲרָה	578 <sup>a</sup> ; 588 <sup>b</sup> ; 1293 <sup>a</sup>	חֲשַׁה	2408 <sup>a</sup>
חֲרַר	2247 <sup>b</sup> ; 3001 <sup>b</sup>	חֲרָה	1443 <sup>a</sup>	חֲשַׁה	1147 <sup>a</sup> ; 2392 <sup>b</sup> ; 2393 <sup>a</sup>
חֲרָשׁ	887 <sup>b</sup>	חֲרָה	1384 <sup>b</sup> ; 1395 <sup>b</sup>	חֲשַׁה	1392 <sup>b</sup>
חֲרָשׁ	1421 <sup>b</sup> ; 1456 <sup>a</sup> ; 2007 <sup>a</sup> ;	חֲרָה	1113 <sup>a</sup> ; 1350 <sup>b</sup>	חֲשַׁה	1490 <sup>b</sup>
	2293 <sup>b</sup> ; 2409 <sup>a</sup> ;	חֲרָה	2597 <sup>b</sup>		
	2813 <sup>b</sup> ; 3027 <sup>b</sup> ;	חֲרָה	1395 <sup>b</sup>		
	3105 <sup>b</sup> ; 3119 <sup>a</sup>				



יהועדן 1574<sup>b</sup>  
 יהועדן 1574<sup>b</sup>  
 יהועדן 1584<sup>b</sup>  
 יהורם 1580<sup>b</sup>; 1736<sup>b</sup>  
 יהושבע 1583<sup>a</sup>  
 יהושבעה 1581<sup>b</sup>  
 יהושע 1424<sup>a</sup>; 1583<sup>b</sup>; 1624<sup>a</sup>;  
 יהושע 1626<sup>a</sup>; 1743<sup>a, b</sup>  
 יהושפט 1431<sup>a</sup>; 1581<sup>b</sup>; 1582<sup>a</sup>;  
 1583<sup>a</sup>; 2759<sup>b</sup>  
 יהלאל 1574<sup>a</sup>  
 יהלם 2 8 5 6<sup>b</sup>; 2 8 5 7<sup>a</sup>;  
 2862<sup>a, b</sup>  
 יחז 1558<sup>a</sup>  
 יחצה 1677<sup>a</sup>  
 יחב 1678<sup>a</sup>; 1695<sup>a</sup>  
 יחצה 1678<sup>a</sup>  
 יחזק 1448<sup>a</sup>; 1688<sup>a, b</sup>  
 יחזק 1575<sup>b</sup>; 1679<sup>a</sup>  
 יחב 1491<sup>a</sup>  
 יחב 1688<sup>a</sup>  
 יחבל 1422<sup>a</sup>; 1546<sup>b</sup>; 1756<sup>a</sup>;  
 יחבל 2100<sup>a</sup>  
 יחבל 2867<sup>a</sup>; 3074<sup>b</sup>  
 יחבל 1756<sup>a</sup>  
 יחזק 1755<sup>b</sup>  
 יחזק 1756<sup>a</sup>  
 יחזק 1695<sup>a</sup>  
 יחזק 1695<sup>b</sup>; 1730<sup>a</sup>  
 יחזק see יחזק  
 יחזק 1727<sup>a</sup>  
 יחזק 1727<sup>a</sup>  
 יחזק 1580<sup>a</sup>; 1727<sup>a</sup>  
 יחזק 1688<sup>a</sup>  
 יחבל 1586<sup>a</sup>  
 יחם 71<sup>a</sup>; 705<sup>a</sup>; 777<sup>a</sup>;  
 797<sup>b</sup>; 798<sup>a</sup>; 799<sup>a, b</sup>;  
 1389<sup>b</sup>; 2049<sup>a</sup>;  
 2982<sup>a</sup>; 3077<sup>a</sup>;  
 3126<sup>a</sup>  
 יחז 1572<sup>a</sup>  
 יחז 1580<sup>a</sup>  
 יחז 871<sup>a</sup>; 1727<sup>b</sup>; 1730<sup>a</sup>  
 יחז 2395<sup>a</sup>  
 יחז 1572<sup>a</sup>  
 יחז 2947<sup>a</sup>  
 יחזק 513<sup>b</sup>; 2947<sup>a</sup>

יחזקאל } 1730<sup>a</sup>; 2488<sup>b</sup>; 2830<sup>b</sup>  
 יחזקאל } 1730<sup>a, b</sup>  
 יחזקאל 1736<sup>b</sup>; 1737<sup>a</sup>  
 יחזקאל 1753<sup>b</sup>  
 יחזקאל 1695<sup>a</sup>  
 יחזקאל 1688<sup>a</sup>  
 יחזקאל 1679<sup>b</sup>  
 יחזקאל 1584<sup>b</sup>  
 יחזקאל 1727<sup>a</sup>  
 יחזקאל 2525<sup>b</sup>; 2982<sup>b</sup>  
 יחזקאל 1732<sup>a</sup>  
 יחזקאל 1732<sup>a</sup>  
 יחזקאל 1580<sup>b</sup>; 1732<sup>a</sup>; 1736<sup>b</sup>  
 יחזקאל 1781<sup>b</sup>  
 יחזקאל 1743<sup>a</sup>  
 יחזקאל 1743<sup>a</sup>  
 יחזקאל 1743<sup>a</sup>  
 יחזקאל 1743<sup>a</sup>  
 יחזקאל 1754<sup>a</sup>  
 יחזקאל 1677<sup>a</sup>  
 יחזקאל 1545<sup>b</sup>  
 יחזקאל 1572<sup>b</sup>  
 יחזקאל 1545<sup>b</sup>  
 יחזקאל } 1675<sup>b</sup>  
 יחזקאל } 2874<sup>b</sup>  
 יחזקאל 1545<sup>b</sup>  
 יחזקאל 1545<sup>b</sup>  
 יחזקאל 993<sup>a</sup>; 1677<sup>a</sup>  
 יחזקאל 1677<sup>a</sup>  
 יחזקאל 1677<sup>a</sup>  
 יחזקאל 1586<sup>a</sup>  
 יחזקאל 3037<sup>b</sup>  
 יחזקאל } 1558<sup>b</sup>  
 יחזקאל } 1558<sup>b</sup>  
 יחזקאל 1574<sup>a</sup>  
 יחזקאל see יחזקאל  
 יחזקאל 1558<sup>b</sup>  
 יחזקאל 1559<sup>a</sup>  
 יחזקאל 1071<sup>a</sup>; 1574<sup>a</sup>  
 יחזקאל } 1574<sup>b</sup>  
 יחזקאל } 1559<sup>a</sup>  
 יחזקאל } 1574<sup>a</sup>; 1586<sup>b</sup>  
 יחזקאל } 1574<sup>a</sup>; 1586<sup>b</sup>

יחזקאל 1574<sup>a</sup>  
 יחזקאל 789<sup>b</sup>; 833<sup>b</sup>  
 יחזקאל 1574<sup>a</sup>  
 יחזקאל 1419<sup>b</sup>  
 יחזקאל 1558<sup>b</sup>; 1573<sup>b</sup>  
 יחזקאל 1558<sup>b</sup>  
 יחזקאל 8 1 7<sup>a, b</sup>; 2 5 9 7<sup>a</sup>;  
 3066<sup>a</sup>; 3155<sup>b</sup>  
 יחזקאל 1558<sup>b</sup>  
 יחזקאל 1558<sup>b</sup>  
 יחזקאל 1559<sup>a</sup>  
 יחזקאל 1558<sup>b</sup>  
 יחזקאל 1183<sup>b</sup>  
 יחזקאל 1183<sup>b</sup>  
 יחזקאל 1558<sup>a</sup>  
 יחזקאל 435<sup>b</sup>; 1276<sup>b</sup>; 1277<sup>a</sup>;  
 2813<sup>b</sup>; 3011<sup>a</sup>  
 יחזקאל 1754<sup>a</sup>  
 יחזקאל 1754<sup>a</sup>  
 יחזקאל } 1788<sup>b</sup>  
 יחזקאל } 1544<sup>b</sup>; 1675<sup>a</sup>  
 יחזקאל 879<sup>b</sup>; 1896<sup>b</sup>; 3086<sup>a</sup>;  
 3088<sup>a</sup>  
 יחזקאל 1334<sup>a</sup>  
 יחזקאל see יחזקאל  
 יחזקאל see יחזקאל  
 יחזקאל 170<sup>b</sup>; 241<sup>a</sup>; 799<sup>a</sup>;  
 2018<sup>b</sup>; 2408<sup>b</sup>;  
 2534<sup>b</sup>; 2535<sup>a</sup>;  
 2560<sup>b</sup>  
 יחזקאל see יחזקאל  
 יחזקאל 1547<sup>b</sup>  
 יחזקאל } 328<sup>a</sup>  
 יחזקאל } 1573<sup>b</sup>  
 יחזקאל } 1577<sup>a</sup>  
 יחזקאל } 418<sup>a</sup>; 426<sup>b</sup>; 522<sup>b</sup>;  
 821<sup>a</sup>; 1183<sup>b</sup>;  
 2034<sup>a</sup>; 2050<sup>a</sup>;  
 2295<sup>a</sup>; 3007<sup>a</sup>  
 יחזקאל 512<sup>b</sup>; 606<sup>b</sup>; 1317<sup>a</sup>  
 יחזקאל 1232<sup>a</sup>  
 יחזקאל 1559<sup>b</sup>  
 יחזקאל 1418<sup>a</sup>; 2815<sup>a</sup>  
 יחזקאל 1121<sup>b</sup>; 1221<sup>a</sup>; 1248<sup>a</sup>

רָשָׁע 2701 <sup>a</sup>	רָעוּר } 1546 <sup>a</sup> ; 1572 <sup>a</sup>	רָעַג 1968 <sup>a</sup>
רָקַק 553 <sup>b</sup> ; 583 <sup>a</sup> ; 1473 <sup>a</sup> ; 1907 <sup>b</sup> ; 1908 <sup>b</sup>	רָעוּר } 1546 <sup>a</sup> ; 1572 <sup>a</sup>	רָעָה 1545 <sup>b</sup> ; 2181 <sup>b</sup>
רָם 128 <sup>a</sup> ; 1547 <sup>a</sup> ; 2026 <sup>b</sup> ; 2037 <sup>a</sup> ; 2145 <sup>b</sup> ; 2153 <sup>b</sup> ; 2538 <sup>b</sup> ; 2706 <sup>b</sup> ; 2838 <sup>a</sup> ; 3082 <sup>a</sup>	רָעַט 704 <sup>b</sup>	רָעָה־רַי 1545 <sup>b</sup>
רָם 128 <sup>a</sup> ; 2093 <sup>b</sup>	רָעִיאַל 1574 <sup>a</sup> ; 1586 <sup>b</sup>	רָעִיעַ 422 <sup>a</sup> ; 591 <sup>b</sup> ; 2863 <sup>a</sup>
רָמוּאֵל 1586 <sup>b</sup>	רָעִיר see רָעִיר	רָעִיק 1493 <sup>b</sup> ; 1843 <sup>b</sup>
רָמוּיָה 1586 <sup>b</sup>	רָעִישׁ 1675 <sup>a</sup>	רָעִיחַ 3154 <sup>b</sup>
רָמוּיָן 128 <sup>a</sup> ; 1333 <sup>b</sup> ; 1567 <sup>b</sup> ; 1865 <sup>b</sup> ; 2591 <sup>a</sup> ; 2838 <sup>a</sup>	רָעִל 288 <sup>b</sup>	רָעִיעַ see רָעִיעַ
רָמוּיָר 1568 <sup>a</sup> ; 2745 <sup>a</sup>	רָעִל 705 <sup>a</sup>	רָעַק 1337 <sup>b</sup>
רָמְלָא } 1456 <sup>b</sup>	רָעִל 592 <sup>b</sup> ; 817 <sup>a,b</sup> ; 1249 <sup>a</sup> ; 1557 <sup>b</sup> ; 1559 <sup>b</sup> ; 3156 <sup>a</sup>	רָעַר 145 <sup>b</sup> ; 1098 <sup>b</sup> ; 1968 <sup>a,b</sup> ; 2425 <sup>b</sup> ; 2864 <sup>a</sup>
רָמְלָה } 1456 <sup>b</sup>	רָעִלָא } 817 <sup>a,b</sup> ; 1249 <sup>a</sup> ; 1545 <sup>a</sup>	רָעַר 1144 <sup>b</sup> ; 1456 <sup>a</sup> ; 1676 <sup>b</sup>
רָמְלָךְ 1568 <sup>a</sup>	רָעִלָה } 817 <sup>a,b</sup> ; 1249 <sup>a</sup> ; 1545 <sup>a</sup>	רָעַר 2030 <sup>a</sup>
רָמְנָה 1461 <sup>b</sup> ; 1677 <sup>a</sup>	רָעִלָם 1559 <sup>b</sup>	רָעַר־רַי 1545 <sup>b</sup> ; 1676 <sup>b</sup>
רָמְנַע 1461 <sup>b</sup>	רָעִנָה 1548 <sup>b</sup> ; 2203 <sup>a</sup> ; 2205 <sup>b</sup> ; 2697 <sup>a</sup> ; 3084 <sup>b</sup>	רָקַב 3086 <sup>b</sup>
רָמְרָה 1466 <sup>a</sup>	רָעִנִי 1568 <sup>a</sup>	רָקַבְצָאֵל 1586 <sup>b</sup>
רָנָח } 1568 <sup>b</sup>	רָעָה 65 <sup>a</sup> ; 1086 <sup>b</sup> ; 1121 <sup>a</sup>	רָקַד 1357 <sup>b</sup>
רָנָה } 1568 <sup>b</sup>	רָעָה 65 <sup>a</sup> ; 1086 <sup>b</sup> ; 1121 <sup>a</sup>	רָקַדְעָם 1727 <sup>a</sup>
רָנִים see רָנִים	רָעָה 65 <sup>a</sup> ; 1086 <sup>b</sup> ; 1121 <sup>a</sup>	רָקָה 1559 <sup>b</sup>
רָנָה 97 <sup>b</sup>	רָעָץ 64 <sup>b</sup> ; 704 <sup>b</sup> ; 1141 <sup>a</sup> ; 1308 <sup>b</sup>	רָקֹה־רַיָאֵל 1586 <sup>b</sup>
רָנִים } 1568 <sup>a,b</sup>	רָעֻב 1549 <sup>a</sup> ; 1556 <sup>a</sup>	רָקָטָן 1727 <sup>b</sup>
רָנִים } 1568 <sup>a,b</sup>	רָעֻבָה 1545 <sup>a</sup> ; 1549 <sup>a</sup>	רָקִים 1559 <sup>b</sup>
רָנַק 513 <sup>b</sup> ; 2947 <sup>a</sup>	רָעֻקָן 435 <sup>b</sup> ; 1547 <sup>b</sup> ; 1559 <sup>b</sup>	רָקִיָה 1586 <sup>b</sup>
רָנְשִׁוּה } 2206 <sup>a</sup> ; 2697 <sup>a</sup>	רָעַר 1132 <sup>a</sup> ; 1377 <sup>a</sup> ; 1545 <sup>b</sup> ; 1812 <sup>b</sup> ; 3001 <sup>b</sup>	רָקִמְעָם 1586 <sup>b</sup>
רָנְשִׁוּה } 2206 <sup>a</sup> ; 2697 <sup>a</sup>	רָעָה 1569 <sup>b</sup>	רָקִמְעָם 1727 <sup>a</sup>
רָסַד 1141 <sup>b</sup> ; 1307 <sup>b</sup>	רָעָרִי אַרְגָּיִם 1545 <sup>b</sup>	רָקִמְעָם 1727 <sup>a</sup>
רָסוּד 411 <sup>a</sup>	רָעָרִים 1572 <sup>b</sup> ; 2197 <sup>a</sup>	רָקַץ 340 <sup>b</sup>
רָסְבָה 1508 <sup>b</sup>	רָעָרְשִׁוּה 1546 <sup>a</sup>	רָקַר 1235 <sup>b</sup> ; 2434 <sup>b</sup>
רָסְמְקָהוּ 1511 <sup>b</sup>	רָעָשׁוּ 1546 <sup>a</sup>	רָקַר 1418 <sup>b</sup>
רָסַם 1150 <sup>b</sup> ; 2116 <sup>a</sup> ; 2459 <sup>a</sup>	רָעָשִׁיאֵל 1546 <sup>a</sup> ; 1571 <sup>a</sup>	רָקַשׁ 1143 <sup>a</sup>
רָסַר 2545 <sup>b</sup>	רָעָה־רַיָאֵל 1546 <sup>a</sup> ; 1571 <sup>a</sup>	רָקַשָׁן 1727 <sup>b</sup>
רָע 2780 <sup>b</sup>	רָעָה־רַיָה 1491 <sup>a</sup>	רָקַחְאֵל 1586 <sup>b</sup> ; 1727 <sup>b</sup>
רָעֲבָץ 1547 <sup>a</sup>	רָעָה 1087 <sup>b</sup> ; 1568 <sup>b</sup>	רָרָא see רָרָה
רָעַד 706 <sup>a</sup>	רָעָה 1087 <sup>b</sup> ; 1278 <sup>b</sup>	רָרָא 1102 <sup>a</sup> ; 2156 <sup>a</sup> ; 2587 <sup>b</sup> ; 2949 <sup>b</sup>
רָעָה } see רָדָה	רָפֹל } 1731 <sup>a</sup>	רָרָה 1102 <sup>a</sup>
רָעָה־רַיָה } see רָדָה	רָפֹלָה 1731 <sup>a</sup>	רָרָה־רַיָאֵן 1492 <sup>b</sup>
רָעָה 2780 <sup>b</sup>	רָפֹח 518 <sup>a</sup>	רָרָה־רַיָה 1492 <sup>a</sup>
רָעִיאַל 1675 <sup>a</sup>	רָפִיעַ 1569 <sup>a</sup>	רָרַב 1569 <sup>b</sup>
רָעִיר 1675 <sup>a</sup>	רָפִלַט 1569 <sup>a</sup>	רָרְבַעַל 1227 <sup>a</sup> ; 1595 <sup>a</sup>
רָעִיר } 1546 <sup>a</sup> ; 1559 <sup>a</sup>	רָפִלַט־רַיָה 1569 <sup>a</sup>	רָרְבַעַם 1593 <sup>a</sup>
רָעִישׁ 1675 <sup>a</sup>	רָפִקָה 1587 <sup>a</sup>	רָרְבַעַת 1595 <sup>a</sup>
רָעִיאַל 1546 <sup>a</sup>	רָפַע 2773 <sup>b</sup>	רָרַר 831 <sup>b</sup> ; 1221 <sup>a</sup> ; 1248 <sup>a</sup>
רָעִיָהוּ 1546 <sup>a</sup>	רָפַח 1568 <sup>b</sup>	רָרַר 1570 <sup>a</sup> ; 1587 <sup>b</sup>
	רָפַחְח 1491 <sup>a</sup> ; 1587 <sup>a</sup> ; 1677 <sup>a</sup>	רָרַדָן 660 <sup>a</sup> ; 1732 <sup>a</sup> ; 1765 <sup>a</sup>
	רָפַחְח־אֵל 1491 <sup>a</sup>	רָרָה } 1852 <sup>b</sup> ; 2921 <sup>a</sup>
	רָצָא 1049 <sup>b</sup> ; 1107 <sup>b</sup> ; 1221 <sup>a</sup> ; 1248 <sup>a</sup> ; 1542 <sup>b</sup> ; 1603 <sup>b</sup> ; 3081 <sup>b</sup> ; 3128 <sup>a</sup>	רָרָאֵל 1595 <sup>b</sup>
	רָצַב 588 <sup>b</sup>	רָרוּם 1570 <sup>a</sup>

ירושא } 1622<sup>a</sup>  
 ירושה }  
 ירושלם } 1596<sup>a</sup>; 1966<sup>a</sup>; 2078<sup>b</sup>;  
 ירושלם } 2663<sup>a</sup>  
 ירושלם }  
 ירח } 303<sup>a</sup>; 1587<sup>a</sup>; 2081<sup>a</sup>;  
 } 2982<sup>b</sup>  
 ירה } 303<sup>a</sup>; 2081<sup>a</sup>  
 ירהו } see ירחו  
 ירחם } 1595<sup>a</sup>  
 ירחמאל } 1587<sup>b</sup>  
 ירחיע } 1570<sup>a</sup>  
 יריאל } 1592<sup>b</sup>  
 יריב } 1570<sup>a</sup>  
 יריבי } 1592<sup>a</sup>  
 יריה } 1592<sup>a</sup>  
 יריהו }  
 יריהו } 1592<sup>a</sup>  
 יריהו }  
 ירימה }  
 ירימה } 1591<sup>a</sup>  
 ירימה }  
 ירימה }  
 יריעה } 767<sup>b</sup>; 2889<sup>b</sup>  
 יריעות } 1593<sup>a</sup>  
 ירה } 411<sup>a</sup>; 492<sup>a</sup>; 1917<sup>a, b</sup>;  
 } 2746<sup>b</sup>; 2972<sup>b</sup>  
 ירקא } 2785<sup>a</sup>; 2972<sup>b</sup>;  
 ירקה } 503<sup>b</sup>  
 ירמיה } 1570<sup>a</sup>  
 ירמות } see ירימות  
 ירמי } 1587<sup>b</sup>  
 ירמיה } 1587<sup>b</sup>; 1588<sup>a</sup>; 2529<sup>a</sup>  
 ירמיהו }  
 ירע } 1306<sup>a</sup>  
 ירפאל } 1492<sup>b</sup>  
 ירק } 2846<sup>a</sup>  
 ירק } 1293<sup>a</sup>  
 ירקון } see יִרְקוֹן  
 ירקון } 2051<sup>b</sup>  
 ירקעם } 1736<sup>b</sup>  
 ירש } 1369<sup>a</sup>; 2420<sup>a</sup>; 2422<sup>b</sup>;  
 } 2426<sup>b</sup>; 2868<sup>b</sup>  
 ירש }  
 ירשה } 1468<sup>b</sup>  
 ירש } 224<sup>a</sup>  
 ישב } 9<sup>a</sup>; 1468<sup>a</sup>; 2743<sup>b</sup>;  
 } 2813<sup>b</sup>  
 ישבא } 1622<sup>a</sup>  
 ישוב בשבח } 1743<sup>a</sup>

ישובו כנב } 1508<sup>b</sup>  
 ישבי כנב }  
 ישבח } 1508<sup>b</sup>  
 ישבי } 1571<sup>a</sup>  
 ישבי לחם } 1571<sup>a</sup>  
 ישבי לחם }  
 ישבעם } 1570<sup>a</sup>  
 ישבק } 1508<sup>b</sup>  
 ישבקשה } 1743<sup>a</sup>  
 ישוב } 1491<sup>a</sup>; 1571<sup>a</sup>  
 ישיב }  
 ישנה } 1511<sup>a</sup>  
 ישנה } 1622<sup>b</sup>  
 ישנה } 1508<sup>b</sup>; 1511<sup>a</sup>  
 ישוע } 1622<sup>b</sup>; 1743<sup>a, b</sup>;  
 } 1749<sup>a</sup>  
 ישחק } 1493<sup>b</sup>  
 ישי } 1509<sup>a</sup>; 1623<sup>a</sup>  
 ישי }  
 ישיב } see ישיב  
 ישיה } 1542<sup>b</sup>  
 ישיהו }  
 ישומאל } 1623<sup>a</sup>  
 ישומון } 831<sup>b</sup>; 1622<sup>a, b</sup>  
 ישומות } see בית הַיְשׁוּמוֹת  
 ישוש } 130<sup>b</sup>  
 ישוש } 1622<sup>b</sup>  
 ישם } 1509<sup>a</sup>  
 ישמא } 1509<sup>a</sup>  
 ישמעאל } 1509<sup>a</sup>  
 ישמעאלי } 1510<sup>b</sup>  
 ישמעיה } 1510<sup>b</sup>  
 ישמעיהו }  
 ישמרי } 1510<sup>b</sup>  
 ישן } 282<sup>b</sup>; 1570<sup>a</sup>; 2817<sup>a</sup>  
 ישן } 443<sup>b</sup>; 1507<sup>b</sup>; 2761<sup>a</sup>  
 ישן } 1622<sup>a</sup>; 2761<sup>a</sup>  
 ישע } 340<sup>a</sup>; 820<sup>b</sup>; 1424<sup>a</sup>;  
 } 2700<sup>a</sup>  
 ישעי } 1509<sup>a</sup>  
 ישעיה } 1495<sup>b</sup>; 1622<sup>a</sup>  
 ישעיהו }  
 ישפה } 2856<sup>b</sup>; 2857<sup>a</sup>; 2860<sup>b</sup>;  
 } 2862<sup>b</sup>  
 ישפה } 1511<sup>a</sup>  
 ישר } 2406<sup>b</sup>  
 ישר } 1622<sup>a</sup>  
 ישר } 2027<sup>b</sup>; 2591<sup>a</sup>

ישר } 1570<sup>a</sup>; 1623<sup>a</sup>; 2027<sup>b</sup>;  
 } 2591<sup>a</sup>; 2864<sup>a</sup>  
 ישראל } 1623<sup>a</sup>  
 ישוראלה } 1622<sup>a</sup>  
 ישורין } 1623<sup>a</sup>  
 יששכר } 1541<sup>b</sup>  
 יחד } 2111<sup>a</sup>; 2207<sup>a</sup>; 2399<sup>a</sup>;  
 } 2743<sup>a</sup>; 2780<sup>b</sup>;  
 } 2847<sup>b</sup>; 3077<sup>b</sup>  
 יחום } 1101<sup>a</sup>; 2202<sup>a</sup>  
 יחור } 2530<sup>a</sup>  
 יחיר } 1050<sup>a</sup>; 1571<sup>a</sup>  
 יחלה } 1543<sup>b</sup>; 1674<sup>a</sup>  
 יחמה } 1543<sup>b</sup>  
 יחניאל } 1571<sup>b</sup>  
 יחר } 7<sup>b</sup>; 2557<sup>a, b</sup>  
 יחר } 709<sup>b</sup>; 1050<sup>a</sup>; 1674<sup>a</sup>;  
 } 2557<sup>b</sup>; 3098<sup>b</sup>  
 יחרא } 1543<sup>b</sup>  
 יחרה } 17<sup>b</sup>; 2590<sup>b</sup>  
 יחרו } 1674<sup>a</sup>  
 יחרון } 896<sup>b</sup>; 1050<sup>a</sup>  
 יחרי } 1543<sup>b</sup>  
 יחרן } 1543<sup>b</sup>  
 יחצם } 1543<sup>b</sup>; 1593<sup>a</sup>  
 יחה } 1674<sup>a</sup>  
 כ }  
 כאב } 2207<sup>a, b</sup>  
 כאב } 1306<sup>a</sup>; 2207<sup>a, b</sup>  
 קבד } 17<sup>b</sup>; 522<sup>b</sup>; 595<sup>a</sup>;  
 } 1236<sup>b</sup>; 1239<sup>a</sup>;  
 } 1294<sup>a</sup>; 1306<sup>b</sup>;  
 } 1337<sup>b</sup>; 1338<sup>a</sup>;  
 } 1354<sup>a, b</sup>; 1418<sup>b</sup>;  
 } 1905<sup>b</sup>; 2154<sup>a</sup>;  
 } 2818<sup>a</sup>  
 כבד } 1306<sup>b</sup>  
 כבד } see כבוד  
 כבדה } 1354<sup>b</sup>  
 כבוד } 1235<sup>b</sup>; 1236<sup>b</sup>; 1253<sup>b</sup>;  
 } 1418<sup>b</sup>; 1906<sup>a</sup>  
 כבדה } 580<sup>b</sup>; 2850<sup>a</sup>  
 כבול } 536<sup>a</sup>  
 כבון } 536<sup>a</sup>  
 כבס } 1148<sup>a</sup>; 3072<sup>b</sup>  
 כבך } 599<sup>a</sup>  
 כברה } 3076<sup>a</sup>  
 כברה } 2976<sup>a</sup>  
 כבש } 1126<sup>a</sup>; 1215<sup>b</sup>; 1822<sup>b</sup>  
 כבשה } 1822<sup>b</sup>

קבשן 1149<sup>b</sup>  
 קב 2401<sup>b</sup>; 2425<sup>b</sup>; 3075<sup>a</sup>  
 קבכד 709<sup>a</sup>; 2858<sup>b</sup>; 2860<sup>b</sup>  
 קבדלעמר 599<sup>a</sup>  
 קבה 1395<sup>b</sup>  
 קבה 1086<sup>b</sup>  
 קבה 1349<sup>b</sup>; 1354<sup>b</sup>  
 קבהן 756<sup>b</sup>; 794<sup>b</sup>; 2436<sup>b</sup>;  
 2439<sup>a</sup>; 2441<sup>b</sup>;  
 2443<sup>a</sup>; 2450<sup>a</sup>;  
 2454<sup>b</sup>; 2624<sup>b</sup>;  
 3129<sup>a</sup>  
 קביב 650<sup>b</sup>; 765<sup>a</sup>  
 קובע 253<sup>b</sup>; 254<sup>a</sup>  
 קובח see קבח  
 קובל 696<sup>a</sup>; 1126<sup>b</sup>; 1308<sup>b</sup>;  
 1403<sup>b</sup>  
 קובן 650<sup>b</sup>; 765<sup>b</sup>; 1098<sup>b</sup>;  
 2027<sup>b</sup>; 2200<sup>b</sup>  
 קובנהו 696<sup>a</sup>  
 קובס 511<sup>b</sup>; 766<sup>a</sup>; 2206<sup>a</sup>;  
 2425<sup>b</sup>  
 קובר 1149<sup>b</sup>  
 קובר see קב  
 קובר-עשן 709<sup>b</sup>  
 קוברש 773<sup>b</sup>; 1507<sup>b</sup>  
 קוברש 767<sup>b</sup>; 768<sup>b</sup>; 769<sup>a</sup>;  
 1031<sup>a</sup>  
 קוברשי 768<sup>b</sup>; 769<sup>a</sup>; 2145<sup>b</sup>;  
 3146<sup>b</sup>  
 קובשית 769<sup>a</sup>  
 קובשן 768<sup>b</sup>  
 קובשן } 768<sup>b</sup>  
 קובשית }  
 קובת } 770<sup>a</sup>  
 קובתה }  
 קובב 1832<sup>a</sup>; 1887<sup>a</sup>  
 קובבא 37<sup>b</sup>; 614<sup>b</sup>  
 קובבי 734<sup>a</sup>  
 קוביב 37<sup>b</sup>  
 קבח { 592<sup>a</sup>; 1106<sup>b</sup>; 1826<sup>b</sup>;  
 1906<sup>a, b</sup>; 1907<sup>a</sup>;  
 2999<sup>b</sup>  
 קבח }  
 קבחד 769<sup>b</sup>  
 קבחל 2208<sup>a</sup>  
 קבחש 432<sup>a</sup>; 830<sup>a</sup>; 1105<sup>a</sup>  
 קבי 588<sup>b</sup>; 1062<sup>b</sup>; 1126<sup>b</sup>;  
 1438<sup>b</sup>  
 קבירון 252<sup>a</sup>; 606<sup>a</sup>; 1279<sup>b</sup>;  
 2108<sup>b</sup>  
 קבירן 612<sup>a</sup>  
 קבירד } 1352<sup>a</sup>; 1436<sup>b</sup>; 1843<sup>b</sup>;  
 קביר } 2237<sup>a</sup>; 2701<sup>a</sup>

קבלי } 655<sup>b</sup>  
 קבלי }  
 קבלה 1325<sup>b</sup>  
 קבמה 311<sup>b</sup>; 312<sup>a</sup>; 313<sup>a</sup>;  
 314<sup>b</sup>  
 קביר 2530<sup>a</sup>  
 קביר see קביר  
 קביר 655<sup>b</sup>; 656<sup>b</sup>; 660<sup>a</sup>;  
 807<sup>b</sup>; 1930<sup>a</sup>;  
 1966<sup>b</sup>; 2076<sup>a</sup>;  
 2210<sup>a</sup>; 2406<sup>b</sup>;  
 2407<sup>a</sup>; 2904<sup>a</sup>  
 קבל } 585<sup>a</sup>; 705<sup>a</sup>; 1439<sup>a</sup>  
 קבל }  
 קבלא 1127<sup>a</sup>; 2569<sup>b</sup>  
 קבלא 2456<sup>a</sup>  
 קבלאב 611<sup>a</sup>  
 קבלאים 2712<sup>b</sup>  
 קבלב 541<sup>a</sup>; 867<sup>b</sup>  
 קבלב 541<sup>a</sup>  
 קבלב אפרתה 541<sup>b</sup>  
 קבלה { 704<sup>b</sup>; 943<sup>a</sup>; 1086<sup>a</sup>;  
 1111<sup>b</sup>; 1199<sup>a</sup>;  
 קבלה } 1780<sup>b</sup>  
 קבלה 2846<sup>b</sup>  
 קבלוב 412<sup>b</sup>; 413<sup>a</sup>; 538<sup>a</sup>;  
 600<sup>b</sup>  
 קבלובי 601<sup>a</sup>  
 קבלוהי 601<sup>a</sup>  
 קבלח 71<sup>a</sup>; 539<sup>b</sup>  
 קבלחונה 674<sup>a</sup>  
 קבלי 254<sup>a</sup>; 261<sup>a</sup>; 377<sup>b</sup>;  
 580<sup>b</sup>; 1150<sup>a</sup>;  
 1483<sup>b</sup>; 1675<sup>b</sup>;  
 2097<sup>a</sup>; 2425<sup>b</sup>;  
 2764<sup>a</sup>; 2867<sup>b</sup>;  
 3049<sup>a</sup>; 3072<sup>a</sup>  
 קבלוה 1797<sup>b</sup>; 2553<sup>b</sup>  
 קבליון 611<sup>a</sup>  
 קבליון 704<sup>b</sup>  
 קבלי 1117<sup>b</sup>; 2320<sup>b</sup>;  
 2639<sup>a, b</sup>  
 קבלבל 541<sup>a</sup>  
 קבלל 1111<sup>a</sup>  
 קבלל 600<sup>b</sup>  
 קבלם 267<sup>a</sup>; 700<sup>b</sup>  
 קבלמד 611<sup>a</sup>  
 קבלמה 700<sup>b</sup>  
 קבלנה } 546<sup>a, b</sup>  
 קבלנה }  
 קבלנו }  
 קבלמהם 611<sup>a</sup>; 1219<sup>b</sup>

קבמוש } 601<sup>a</sup>; 2070<sup>b</sup>  
 קבמיש }  
 קבמן 765<sup>b</sup>; 1123<sup>a</sup>  
 קבמירר 485<sup>a</sup>  
 קבן 410<sup>b</sup>; 1118<sup>b</sup>; 1240<sup>a</sup>;  
 1438<sup>b</sup>; 1886<sup>b</sup>;  
 1887<sup>a</sup>; 2180<sup>b</sup>;  
 2295<sup>a</sup>; 2404<sup>b</sup>;  
 2688<sup>b</sup>  
 קבנה 553<sup>b</sup>  
 קבנור 660<sup>a</sup>; 791<sup>a</sup>; 2095<sup>a</sup>;  
 2097<sup>a</sup>; 2101<sup>a</sup>  
 קבנהו 701<sup>a</sup>; 1577<sup>a</sup>  
 קבני 602<sup>b</sup>  
 קבנהו } 602<sup>b</sup>  
 קבנהו }  
 קבנע 522<sup>b</sup>  
 קבנעה 3072<sup>a</sup>  
 קבנען 549<sup>a</sup>; 1202<sup>a</sup>; 3002<sup>a</sup>;  
 3004<sup>b</sup>  
 קבנעה 602<sup>b</sup>  
 קבנעני 3002<sup>a</sup>  
 קבנה 721<sup>b</sup>  
 קבנה 887<sup>a</sup>; 943<sup>a</sup>; 1143<sup>a</sup>;  
 2814<sup>b</sup>; 3088<sup>b</sup>  
 קבנרות } 611<sup>a, b</sup>; 656<sup>a</sup>; 1165<sup>b</sup>;  
 קבנרת } 2706<sup>b</sup>  
 קבסא } 303<sup>b</sup>  
 קבסה }  
 קבסא } 1801<sup>b</sup>; 2710<sup>b</sup>; 2862<sup>b</sup>;  
 קבסה } 2976<sup>a</sup>  
 קבסה 669<sup>b</sup>; 733<sup>a</sup>  
 קבסה see קבסא  
 קבסה see קבסא  
 קבסרת 733<sup>a</sup>  
 קבסיל 311<sup>b</sup>; 312<sup>a, b</sup>; 313<sup>a</sup>;  
 314<sup>b</sup>; 444<sup>b</sup>; 605<sup>a</sup>;  
 704<sup>b</sup>; 1124<sup>a, b</sup>  
 קבסל 700<sup>a</sup>; 1917<sup>a, b</sup>  
 קבסלה 700<sup>a</sup>  
 קבסלו 541<sup>b</sup>; 1813<sup>b</sup>  
 קבסלון 612<sup>a</sup>  
 קבסלון 604<sup>b</sup>  
 קבסלות 605<sup>b</sup>  
 קבסלקהים 581<sup>b</sup>  
 קבסם 2415<sup>b</sup>  
 קבסמת 1117<sup>b</sup>; 1122<sup>a</sup>; 2840<sup>a</sup>  
 קבסה 832<sup>b</sup>  
 קבסה 581<sup>b</sup>; 1447<sup>b</sup>; 2076<sup>a, b</sup>;  
 2395<sup>a</sup>; 2792<sup>b</sup>;  
 2793<sup>a</sup>

**קספא** 581<sup>b</sup>  
**קעס** 1305<sup>b</sup>; 1306<sup>a</sup>; 2486<sup>b</sup>  
**קה** 1333<sup>b</sup>; 1334<sup>b</sup>; 1335<sup>a</sup>;  
 1404<sup>b</sup>; 2235<sup>a</sup>;  
 2293<sup>a</sup>; 2846<sup>a</sup>  
**קה** 2596<sup>a</sup>  
**קעה** 513<sup>b</sup>  
**קפור** 1147<sup>a</sup>  
**קפיס** 417<sup>a</sup>  
**קפיר** 1895<sup>a</sup>; 1896<sup>a</sup>; 3049<sup>b</sup>  
**קפירה** 602<sup>b</sup>  
**קפל** 870<sup>b</sup>  
**קפן** 1097<sup>a</sup>  
**קפה** 599<sup>a</sup>; 2235<sup>a</sup>  
**קפר** 137<sup>b</sup>; 321<sup>a, b</sup>; 668<sup>a</sup>;  
 1069<sup>a</sup>; 1132<sup>b</sup>;  
 1133<sup>a</sup>; 2019<sup>b</sup>;  
 2020<sup>a</sup>; 2036<sup>a</sup>;  
 2401<sup>b</sup>; 2506<sup>b</sup>;  
 2531<sup>a</sup>; 2536<sup>a</sup>;  
 2808<sup>a</sup>  
**קפר** 3049<sup>b</sup>  
**קפר** 520<sup>b</sup>; 1279<sup>b</sup>; 2022<sup>a</sup>;  
 2401<sup>b</sup>; 2530<sup>a, b</sup>;  
 2531<sup>a, b</sup>; 2651<sup>a</sup>;  
 2655<sup>a</sup>; 2697<sup>a</sup>;  
 2817<sup>b</sup>; 3049<sup>b</sup>  
**קפר** 326<sup>a</sup>  
**קפר העמוני** 602<sup>b</sup>  
**קפרת** 242<sup>b</sup>; 327<sup>b</sup>; 1063<sup>a</sup>;  
 2036<sup>a</sup>  
**קפתר** } 568<sup>a</sup>; 1815<sup>b</sup>  
**קפתור** }  
**קפתרי** 568<sup>a</sup>  
**קר** 569<sup>a</sup>; 1150<sup>a</sup>; 1822<sup>b</sup>;  
 2527<sup>b</sup>  
**קר** } 709<sup>a</sup>; 3080<sup>a</sup>  
**קור** }  
**קרבלא** 1343<sup>a</sup>  
**קרה** 533<sup>a</sup>  
**קרוב** 603<sup>b</sup>; 739<sup>a</sup>  
**קרוז** 1375<sup>a</sup>  
**קרי** 578<sup>b</sup>; 2379<sup>b</sup>; 2787<sup>a</sup>  
**קריה** 603<sup>a</sup>  
**קרנב** 694<sup>b</sup>; 1864<sup>b</sup>  
**קרנפס** 2661<sup>a</sup>  
**קרמיש** 576<sup>b</sup>  
**קרנפס** 576<sup>b</sup>; 1423<sup>b</sup>  
**קרנרה** 419<sup>a</sup>; 547<sup>b</sup>; 548<sup>a</sup>;  
 2875<sup>b</sup>  
**קרמי** 579<sup>b</sup>  
**קרמיל** 675<sup>b</sup>; 884<sup>a</sup>  
**קרמל** 579<sup>a</sup>; 2523<sup>b</sup>

**קרמלי** 579<sup>b</sup>  
**קרמלית** 579<sup>b</sup>  
**קרע** 1104<sup>b</sup>; 1865<sup>a</sup>  
**קרע** 1865<sup>a</sup>  
**קרפס** 723<sup>a</sup>  
**קרטש** 2013<sup>a</sup>  
**קרש** see **כורש**  
**קרשנא** 580<sup>b</sup>  
**קרת** 728<sup>a, b</sup>; 746<sup>a</sup>; 769<sup>b</sup>;  
 1086<sup>a</sup>; 1966<sup>b</sup>;  
 2256<sup>b</sup>; 3008<sup>b</sup>  
**קרתי** 255<sup>b</sup>; 603<sup>a</sup>; 2379<sup>a, b</sup>  
**קשוב** 1822<sup>b</sup>; 3155<sup>b</sup>  
**קטובה** 1822<sup>b</sup>  
**קטורי** } 589<sup>b</sup>; 605<sup>a</sup>; 2147<sup>b</sup>;  
**קטורמה** } 2218<sup>a</sup>; 3039<sup>a</sup>;  
 3042<sup>b</sup>  
**קטורי** 862<sup>b</sup>  
**קטויל** 342<sup>a</sup>; 1344<sup>a</sup>  
**קטל** 439<sup>b</sup>; 815<sup>a</sup>; 1105<sup>a</sup>  
**קטה** 1964<sup>b</sup>; 3097<sup>a</sup>  
**קטה** 3097<sup>b</sup>  
**קטר** 896<sup>b</sup>; 968<sup>a</sup>; 1122<sup>a</sup>  
**קטרון** 896<sup>b</sup>; 968<sup>a</sup>; 1277<sup>b</sup>  
**קתב** 723<sup>b</sup>; 831<sup>b</sup>; 3119<sup>a</sup>  
**קתב** 2487<sup>a</sup>; 2628<sup>b</sup>  
**קתי** } 605<sup>b</sup>; 1814<sup>b</sup>  
**קתירי** }  
**קתליש** 612<sup>a</sup>; 1814<sup>a</sup>  
**קתם** 1985<sup>b</sup>  
**קתם** 709<sup>a</sup>; 1274<sup>a</sup>; 3078<sup>b</sup>  
**קתנת** } 669<sup>a</sup>; 876<sup>a, b</sup>; 877<sup>a</sup>;  
**קתנת** } 1984<sup>a</sup>  
**קתה** 246<sup>b</sup>; 721<sup>b</sup>; 2780<sup>a, b</sup>;  
 3037<sup>a</sup>  
**קתה** 762<sup>a, b</sup>  
**קתה** 762<sup>a, b</sup>; 763<sup>a</sup>  
**קתש** 514<sup>b</sup>  
**קתח** 523<sup>a</sup>; 723<sup>b</sup>  
  
**ל**  
**לא** } 1127<sup>a</sup>; 2156<sup>b</sup>; 2411<sup>a</sup>;  
**לא** } 2961<sup>b</sup>  
**לא** }  
**לא דבר** }  
**לו דבר** } 1887<sup>a</sup>; 1909<sup>b</sup>  
**לדבר** }  
**לדבר** }  
**לאה** 1306<sup>a</sup>

**לאה** 1861<sup>b</sup>; 1868<sup>b</sup>  
**לאום** see **לאם**  
**לאל** 1821<sup>b</sup>  
**לאם** } 1121<sup>b</sup>; 2319<sup>a</sup>  
**לאום** }  
**לאמים** 1868<sup>b</sup>  
**לא עמי** 1426<sup>b</sup>; 1907<sup>a</sup>  
**לא רחמה** 1426<sup>b</sup>; 1907<sup>a</sup>  
**לב** 376<sup>b</sup>; 449<sup>a</sup>; 523<sup>b</sup>;  
 577<sup>b</sup>; 678<sup>b</sup>; 1350<sup>b</sup>;  
 1351<sup>b</sup>; 2056<sup>a</sup>;  
 3089<sup>a</sup>  
**לבאות** 1864<sup>a</sup>  
**לבב** 3089<sup>a</sup>  
**לבב** 724<sup>b</sup>; 1350<sup>b</sup>; 2496<sup>b</sup>  
**לבונה** } 1111<sup>a</sup>; 1144<sup>b</sup>; 1145<sup>a</sup>;  
**לבנה** } 1466<sup>b</sup>; 1864<sup>a</sup>;  
 2639<sup>a, b</sup>  
**לביא** }  
**לביא** } 1895<sup>a</sup>; 3083<sup>a</sup>  
**לבאים** }  
**לבאות** }  
**לבן** 1111<sup>a</sup>  
**לבן** } 676<sup>a</sup>; 1145<sup>a</sup>; 1862<sup>b</sup>  
**לבן** }  
**לבן** } 1819<sup>a</sup>  
**לבן** }  
**לבנא** } 1862<sup>b</sup>  
**לבנה** }  
**לבנה** } 2421<sup>a</sup>  
**לבנה** } 1881<sup>b</sup>; 2768<sup>a</sup>  
**לבנה** } 301<sup>b</sup>; see also **לבנא**  
**לבנה** } 520<sup>b</sup>; 2981<sup>b</sup>  
**לבנה** } see **לבונה**  
**לבנון** 1862<sup>b</sup>; 3000<sup>b</sup>  
**לבני** 1882<sup>a</sup>  
**לבש** } 259<sup>b</sup>; 678<sup>b</sup>  
**לבש** }  
**לבש** } see **לבוש**  
**לג** 1910<sup>a</sup>; 3080<sup>a</sup>  
**לד** 1909<sup>a</sup>  
**לדבר** see **לא דבר**  
**להב** 1117<sup>b</sup>; 1235<sup>a</sup>  
**להקה** } 1348<sup>a</sup>  
**להבת** }  
**להבים** } 1865<sup>b</sup>  
**להד** 1821<sup>b</sup>  
**להט** 942<sup>a</sup>  
**לוא** see **לא**

לא }  
 לא } 1336<sup>b</sup>  
 לה }  
 להבי }  
 להבי } 1934<sup>b</sup>  
 להד } 1935<sup>a</sup>  
 להדי }  
 להדי } 1935<sup>a</sup>  
 להה } 741<sup>a</sup>; 1865<sup>b</sup>; 1868<sup>b</sup>  
 להז } 100<sup>a,b</sup>; 1942<sup>a</sup>; 2348<sup>a</sup>  
 להח } 491<sup>a</sup>; 2408<sup>a</sup>; 2898<sup>a</sup>;  
 להח } 2900<sup>b</sup>; 2901<sup>a</sup>  
 להחית }  
 להחית } 1935<sup>b</sup>  
 להחש } 1423<sup>a</sup>  
 להחש } 733<sup>a</sup>; 1929<sup>b</sup>  
 להחש } 1931<sup>b</sup>  
 להי } 1868<sup>b</sup>  
 להי } 2446<sup>b</sup>  
 להי } 309<sup>a</sup>; 1868<sup>b</sup>  
 להי }  
 להי } 1307<sup>b</sup>; 1910<sup>a</sup>; 2094<sup>b</sup>  
 להי }  
 להי } 115<sup>a</sup>; 831<sup>b</sup>; 2072<sup>b</sup>;  
 להי } 2703<sup>a</sup>  
 להחית } see להחית  
 להח } 3098<sup>b</sup>  
 להח } 2122<sup>b</sup>  
 להח } see להח  
 להח }  
 להח } 1118<sup>b</sup>  
 להח }  
 להח } 600<sup>a</sup>; 1572<sup>a</sup>  
 להח } 514<sup>b</sup>; 1118<sup>b</sup>; 1122<sup>a</sup>;  
 להח } 2767<sup>a</sup>  
 להח } see להח  
 להח } 1821<sup>b</sup>  
 להח } 1821<sup>b</sup>  
 להח } 2198<sup>a</sup>  
 להח } 862<sup>b</sup>; 942<sup>b</sup>; 1964<sup>b</sup>;  
 להח } 2594<sup>b</sup>  
 להח } 126<sup>b</sup>; 887<sup>a</sup>; 1964<sup>b</sup>;  
 להח } 2199<sup>a</sup>  
 להח } 942<sup>b</sup>  
 להח } 1821<sup>a</sup>; 2102<sup>b</sup>  
 להח } 1106<sup>b</sup>; 1906<sup>a</sup>; 1907<sup>a</sup>  
 להח } 1868<sup>b</sup>  
 להח } 1132<sup>b</sup>; 3027<sup>b</sup>

ליל }  
 ליל } 798<sup>a</sup>; 2050<sup>a</sup>; 2145<sup>a</sup>;  
 ליל } 2256<sup>b</sup>  
 לילה }  
 לילה } 369<sup>a</sup>; 2206<sup>a</sup>; 2697<sup>a</sup>  
 ליש } 1821<sup>b</sup>; 1822<sup>a</sup>;  
 ליש } 1895<sup>a,b</sup>; 1896<sup>a</sup>  
 ליש } 1820<sup>a</sup>  
 לקאה } 1919<sup>a</sup>  
 לקה } 2581<sup>b</sup>; 2813<sup>b</sup>; 2921<sup>a</sup>  
 לקה }  
 לקה } 1865<sup>b</sup>  
 לקה } 1823<sup>b</sup>  
 לקה } 831<sup>b</sup>; 1843<sup>b</sup>; 2072<sup>b</sup>;  
 לקה } 2703<sup>a</sup>  
 לקה } 2703<sup>a</sup>  
 לקה } 2072<sup>b</sup>  
 לקה } 1819<sup>a</sup>  
 לקה } 1821<sup>a</sup>  
 לקה } 1167<sup>a</sup>; 3109<sup>b</sup>; 3110<sup>a</sup>  
 לקה } 514<sup>a</sup>; 1112<sup>b</sup>; 1825<sup>a</sup>;  
 לקה } 2999<sup>b</sup>  
 לקה } 1839<sup>b</sup>  
 לקה } 2703<sup>a</sup>  
 לקה } 2703<sup>a</sup>  
 לקה } 1822<sup>b</sup>  
 לקה } 533<sup>a</sup>; 1107<sup>b</sup>  
 לקה } 866<sup>b</sup>; 1087<sup>b</sup>  
 לקה } 1893<sup>a</sup>  
 לקה } 1234<sup>b</sup>  
 לקה } 1839<sup>b</sup>; 1907<sup>b</sup>  
 לקה } 1293<sup>a</sup>  
 לקה } 1145<sup>b</sup>  
 לקה } 348<sup>b</sup>; 416<sup>b</sup>; 474<sup>b</sup>;  
 לקה } 1043<sup>a</sup>; 2994<sup>b</sup>;  
 לקה } 3078<sup>b</sup>  
 לקה } 591<sup>b</sup>; 1308<sup>b</sup>; 1470<sup>b</sup>;  
 לקה } 2747<sup>a</sup>  
 לקה } 1840<sup>a</sup>; 2856<sup>a</sup>; 2857<sup>b</sup>;  
 לקה } 2859<sup>a</sup>; 2860<sup>b</sup>  
 לקה } 2814<sup>b</sup>  
 לקה } 1840<sup>a</sup>  
 לקה } 1868<sup>b</sup>; 3080<sup>a</sup>  
 מ }  
 מאברס } 2863<sup>a</sup>  
 מאד } 1294<sup>a</sup>; 1780<sup>a</sup>; 2839<sup>b</sup>;  
 מאד } 3048<sup>b</sup>  
 מאה }  
 מאה } 1325<sup>a</sup>; 1440<sup>a</sup>; 2013<sup>a</sup>

מואל } see מואל  
 מאום } 486<sup>b</sup>; 490<sup>b</sup>; 2846<sup>t</sup>  
 מום }  
 מאומה } 1101<sup>b</sup>; 2156<sup>b</sup>  
 מאור }  
 מאור } 1890<sup>b</sup>  
 מאורה }  
 מאורה } 829<sup>b</sup>  
 מאונ } 379<sup>b</sup>  
 מאנה } see מאנה  
 מאנקל } 1815<sup>b</sup>  
 מאנקל } 1147<sup>a</sup>  
 מאמץ } 1127<sup>a</sup>  
 מאמר } 1260<sup>a</sup>; 1699<sup>a</sup>  
 מאר } 1145<sup>b</sup>; 1868<sup>a</sup>  
 מאר } see מאור  
 מארב } 115<sup>b</sup>  
 מארה } 767<sup>a</sup>  
 מארה } see מאור  
 מבוא } 1273<sup>a</sup>; 3082<sup>a</sup>  
 מבול } 1120<sup>a</sup>  
 מבוץ } 3081<sup>b</sup>  
 מבחר } 2045<sup>a</sup>  
 מבטח } 700<sup>a</sup>; 1419<sup>b</sup>  
 מבנה } 1144<sup>b</sup>  
 מבני } 2016<sup>b</sup>  
 מבצר } 1106<sup>b</sup>; 1136<sup>b</sup>; 1137<sup>a</sup>;  
 מבצר } 1140<sup>a,b</sup>; 2045<sup>b</sup>  
 מבחר } 1148<sup>a</sup>  
 מבשם } 2045<sup>b</sup>  
 מבשלה } 494<sup>b</sup>  
 מג } see מג  
 מגביש } 1962<sup>a</sup>  
 מגדון } 1340<sup>a</sup>; 2027<sup>b</sup>  
 מגהו }  
 מגדול } 355<sup>b</sup>; 2003<sup>b</sup>; 2050<sup>b</sup>;  
 מגדול } 2222<sup>a</sup>; 2501<sup>b</sup>  
 מגדול } 1962<sup>a</sup>  
 מגדל } 1137<sup>a</sup>; 1544<sup>b</sup>; 1603<sup>b</sup>;  
 מגדל } 1610<sup>b</sup>; 1962<sup>a</sup>;  
 מגדל } 3000<sup>b</sup>  
 מגדל } see מגדול  
 מגדל } see מגדל  
 מגדל-אל } 2050<sup>a</sup>  
 מגדל-גד } 2050<sup>b</sup>  
 מגדל } 1965<sup>b</sup>



מגור }  
מגור } 2398<sup>b</sup>  
מגר }  
מגורה 405<sup>a</sup>  
מגור מסריב 1965<sup>b</sup>; 2255<sup>b</sup>  
מגורה 341<sup>b</sup>  
מגל 2784<sup>a</sup>  
מגלה 555<sup>a</sup>; 896<sup>a</sup>; 1006<sup>a</sup>;  
1825<sup>a</sup>; 2507<sup>b</sup>;  
2597<sup>a,b</sup>; 2628<sup>b</sup>;  
2910<sup>a</sup>; 3058<sup>a</sup>  
מגן 820<sup>b</sup>  
מגן } 252<sup>b</sup>; 253<sup>a</sup>; 2626<sup>b</sup>;  
מגנה } 2701<sup>a,b</sup>; 2789<sup>a</sup>  
מגפה 2402<sup>a</sup>; 2808<sup>b</sup>  
מגרה 341<sup>b</sup>  
מגרון 2051<sup>a</sup>  
מגרפה 669<sup>b</sup>; 2976<sup>a</sup>  
מד } 251<sup>a</sup>; 2016<sup>a</sup>; 2850<sup>a</sup>  
מד }  
מדבר 831<sup>b</sup>; 2707<sup>a</sup>; 2838<sup>a</sup>  
מדר 2016<sup>a</sup>; 2044<sup>b</sup>  
מדה 2016<sup>a</sup>; 2045<sup>a</sup>; 2545<sup>a</sup>;  
2850<sup>a</sup>; 2918<sup>a</sup>;  
2994<sup>a</sup>; 3010<sup>b</sup>  
מדהבה 1275<sup>a</sup>  
מדון 1961<sup>b</sup>  
מדירה } 2398<sup>b</sup>  
מירה }  
מדי 611<sup>a</sup>; 1337<sup>a</sup>; 1961<sup>b</sup>;  
2018<sup>a</sup>  
מדין 514<sup>a</sup>; 2049<sup>a</sup>  
מדין 2049<sup>a</sup>  
מדינה 896<sup>b</sup>; 1008<sup>b</sup>; 2485<sup>b</sup>  
מדיני 514<sup>a</sup>; 2049<sup>a,b</sup>  
מדכה 2083<sup>a</sup>  
מדמן 1961<sup>b</sup>  
מדמקה 882<sup>b</sup>; 1961<sup>b</sup>  
מדמקה 1961<sup>b</sup>  
מדן 2016<sup>b</sup>  
מדע see מדע  
מירה see מדירה  
מדרש 687<sup>a</sup>; 2050<sup>a</sup>; 2184<sup>a</sup>  
מדתא 1325<sup>b</sup>  
מה }  
מ } 381<sup>b</sup>; 1438<sup>b</sup>; 1439<sup>a</sup>  
מה }  
מהומה 852<sup>a</sup>  
מהומן 2028<sup>a</sup>  
מהיטבאל 2028<sup>a</sup>

מהיר } 1343<sup>a</sup>; 2534<sup>a</sup>  
מהר }  
מהללא 1965<sup>b</sup>  
מהפכת 2456<sup>a</sup>  
מהר 944<sup>b</sup>; 1102<sup>a</sup>; 1343<sup>a</sup>  
מהר see מהיר  
מהר 863<sup>b</sup>; 872<sup>b</sup>; 1997<sup>b</sup>  
מהרי 1966<sup>b</sup>  
מהר של } 1967<sup>a</sup>; 2439<sup>a</sup>  
הש }  
מזאב 1810<sup>b</sup>; 2069<sup>a,b</sup>;  
2207<sup>a</sup>  
מזאבי }  
מזאבה } 2069<sup>b</sup>; 2072<sup>b</sup>  
מזאבת }  
מזאל see מזל  
מזע } 1810<sup>b</sup>  
מזע }  
מזעת 1799<sup>a</sup>; 1810<sup>b</sup>  
מזט 402<sup>a</sup>; 3126<sup>b</sup>  
מזטה 382<sup>a</sup>; 1354<sup>a</sup>; 2850<sup>a</sup>;  
3126<sup>b</sup>  
מזל }  
מזל } 656<sup>b</sup>; 1127<sup>b</sup>  
מזאל }  
מזל }  
מזלה 2073<sup>b</sup>  
מזלת 1542<sup>b</sup>; 1799<sup>a</sup>  
מזלה 656<sup>b</sup>  
מזלד 486<sup>b</sup>; 2075<sup>b</sup>  
מזם see מאים  
מזמן see במזמן  
מזסדה 1307<sup>b</sup>  
מזסר }  
מזסרה } 2083<sup>b</sup>; 3127<sup>a</sup>  
מזסרה }  
מזסר 598<sup>b</sup>; 599<sup>a</sup>; 722<sup>b</sup>;  
852<sup>a</sup>; 866<sup>b</sup>; 2535<sup>a</sup>  
מזסרה } 2083<sup>b</sup>  
מזסרות }  
מזער } 303<sup>b</sup>; 701<sup>a</sup>; 1103<sup>a</sup>;  
מזער } 2822<sup>a</sup>; 2887<sup>b</sup>;  
מזערה } 2888<sup>b</sup>  
מזפעת }  
מזפעת } 2033<sup>b</sup>  
מזפעת }  
מזפת } 2063<sup>a</sup>; 2789<sup>a</sup>; 3104<sup>b</sup>  
מזפת }

מוצא } 1273<sup>a</sup>; 2093<sup>b</sup>; 2205<sup>a</sup>;  
מוצא } 3047<sup>b</sup>; 3081<sup>b</sup>  
מוצק } 1338<sup>a</sup>; 2864<sup>a</sup>  
מוצק }  
מוקד 1112<sup>b</sup>  
מוקדה 1351<sup>b</sup>  
מוקש } 1231<sup>b</sup>; 1352<sup>a</sup>;  
מוקש } 1441<sup>a,b</sup>; 2180<sup>a</sup>;  
מוקש } 3007<sup>a</sup>  
מור 594<sup>a</sup>  
מורא }  
מורא } 2118<sup>a</sup>; 2082<sup>a</sup>; 2533<sup>b</sup>  
מורה }  
מורג } 2976<sup>a</sup>  
מרג }  
מורה } 119<sup>b</sup>; 331<sup>a</sup>; 2525<sup>b</sup>  
מרה }  
מורה see מורא  
מוריה } 2082<sup>b</sup>  
מריה }  
מורשה 1468<sup>b</sup>  
מורשת פת 2082<sup>a</sup>  
מורשתאי 2081<sup>b</sup>  
מוש 1105<sup>a</sup>  
מושב } 1313<sup>a</sup>  
משב }  
משי } 2094<sup>b</sup>  
משי }  
מושקה 314<sup>b</sup>  
מות 408<sup>a</sup>; 764<sup>b</sup>; 800<sup>b</sup>;  
848<sup>b</sup>  
מות } 801<sup>a</sup>; 811<sup>a</sup>; 2746<sup>a</sup>  
מתן }  
מות לבן 2102<sup>a</sup>; 2488<sup>b</sup>; 2831<sup>a</sup>  
מותר 2437<sup>a</sup>  
מזבם 106<sup>b</sup>; 110<sup>b</sup>; 1522<sup>b</sup>;  
1534<sup>a</sup>  
מזג 3086<sup>b</sup>  
מזה 2069<sup>b</sup>  
מזוזה } 126<sup>b</sup>; 128<sup>a</sup>  
מזוזה }  
מזזיר 2538<sup>a</sup>  
מזלג } 1119<sup>b</sup>; 1419<sup>a</sup>  
מזלקה }  
מזלה 312<sup>b</sup>; 313<sup>a,b</sup>; 2407<sup>b</sup>  
מזמה 1880<sup>b</sup>; 3097<sup>a</sup>  
מזמור 2487<sup>a</sup>  
מזמרה 1419<sup>a</sup>  
מזמרה 2820<sup>a</sup>

מִזְרָה	1097 <sup>b</sup> ; 2976 <sup>a</sup>	מִתְרַת	} 2083 <sup>a</sup>	מִכָּאָב	} 1306 <sup>a</sup> ; 2207 <sup>a</sup> ; 2836 <sup>b</sup>	
מִזְרָה	313 <sup>b</sup> ; 2155 <sup>b</sup>	מִתְרָתָם				מִכָּאָב
מִזְרָה	310 <sup>a</sup> ; 311 <sup>a</sup> ; 312 <sup>b</sup> ; 313 <sup>a</sup> ; 314 <sup>a</sup>	מִתְשָׁבֵה	} 766 <sup>a</sup> ; 767 <sup>a</sup> ; 840 <sup>a</sup> ; 2975 <sup>a</sup>	מִכָּאָה		
מִזְרַח	888 <sup>b</sup> ; 3082 <sup>a</sup>	מִתַּת		1966 <sup>b</sup>	מִכְבִּיר	17 <sup>b</sup>
מִזְרָק	511 <sup>b</sup>	מִתְהַתָּה	587 <sup>b</sup> ; 1113 <sup>a</sup> ; 2237 <sup>a</sup> ; 2820 <sup>a</sup>	מִכְבָּנָא	1959 <sup>b</sup>	
מִתָּ	1999 <sup>b</sup>	מִתְאַטָּא	2976 <sup>a</sup>	מִכְבָּנִי	1959 <sup>b</sup>	
מִתָּא	665 <sup>b</sup>	מִטְּהָ	} 513 <sup>b</sup> ; 1185 <sup>b</sup> ; 2596 <sup>b</sup> ; 2702 <sup>a</sup> ; 2847 <sup>b</sup> ; 3010 <sup>a</sup>	מִכְבָּר	1293 <sup>b</sup>	
מִתְּבַת	515 <sup>b</sup> ; 2237 <sup>a</sup>	מִטְּהָ			מִכְּהָ	} 2402 <sup>a</sup> ; 2836 <sup>b</sup>
מִתָּחָ	15 <sup>a</sup> ; 490 <sup>b</sup> ; 1999 <sup>b</sup>	מִטְּהָ		מִכּוּנָה	} 410 <sup>b</sup> ; 2016 <sup>b</sup> ; 2023 <sup>b</sup>	
מִתְּוִינָה	694 <sup>a</sup>	מִטְּהָ	422 <sup>a, b</sup> ; 472 <sup>b</sup> ; 530 <sup>a</sup> ; 1905 <sup>b</sup>	מִכְּנָה		
מִתְּוִזָּ	1344 <sup>b</sup>	מִטִּיל	402 <sup>a</sup>	מִכְּרִי	1959 <sup>b</sup>	
מִתְּוִינָאָל	} 2028 <sup>a</sup>	מִטְּמוֹן	} 3007 <sup>b</sup>	מִכְּרִי	1959 <sup>b</sup>	
מִתְּוִינָאָל				מִטְּמוֹן		מִכְּלָאָה
מִתְּוִינָאָל		מִטְּמוֹן			מִכְּלָה	
מִתְּוִינָאָל	1967 <sup>a</sup>	מִטְּמוֹן		מִכְּלֹל	1279 <sup>b</sup>	
מִתְּוִינָאָל	1967 <sup>a</sup>	מִטְּמוֹן		מִכְּלָל	2321 <sup>a</sup>	
מִתְּוִינָאָל	see מִתְּוִינָאָל	מִטְּעָם	777 <sup>a</sup>	מִכְּמֶן	3007 <sup>b</sup>	
מִתְּוִינָאָל	2581 <sup>a</sup>	מִטְּעָמָה		מִכְּמָם		
מִתְּוִינָאָת	1967 <sup>a</sup>	מִטְּפַחָת	3047 <sup>a</sup>	מִכְּמָשׁ	} 2048 <sup>a</sup>	
מִתְּוִינָאָת	2028 <sup>a</sup>	מִטְּרָ	2525 <sup>b</sup>	מִכְּמָשׁ		
מִתְּוִינָאָת	2515 <sup>a, b</sup> ; 2587 <sup>b</sup>	מִטְּרָא	} 1986 <sup>a</sup> ; 2465 <sup>a</sup>	מִכְּמָרְתָּ	} 1115 <sup>a</sup>	
מִתְּוִינָאָת	1153 <sup>b</sup> ; 2028 <sup>a</sup>	מִטְּרָה				מִכְּמָרְתָּ
מִתְּוִינָאָת	} 1468 <sup>a</sup> ; 1965 <sup>b</sup> ; 1967 <sup>a</sup> ; 2783 <sup>a</sup>	מִטְּרַד	2008 <sup>a</sup>	מִכְּמָשׁ	see מִכְּמָם	
מִתְּוִינָאָת			מִטְּרִי	2008 <sup>a</sup>	מִכְּמָתָת	2049 <sup>a</sup>
מִתְּוִינָאָת	585 <sup>a</sup>	מִיְדָבָא	2017 <sup>a</sup>	מִכְּנָדְבִיר	1959 <sup>b</sup>	
מִתְּוִינָאָת	1967 <sup>a</sup>	מִיְדָד	2016 <sup>b</sup>	מִכּוּנָה	see מִכּוּנָה	
מִתְּוִינָאָת	1967 <sup>a</sup>	מִיְהִיבְרָקוֹן	2028 <sup>a</sup>	מִכְּנָס	518 <sup>a</sup>	
מִתְּוִינָאָת	1815 <sup>b</sup>	מִיְזָב	2045 <sup>a</sup>	מִכְּסָ	3010 <sup>b</sup>	
מִתְּוִינָאָת	1907 <sup>a, b</sup>	מִיכָא	2045 <sup>b</sup>	מִכְּסָה	733 <sup>a</sup>	
מִתְּוִינָאָת	2216 <sup>a</sup> ; 2714 <sup>a</sup>	מִיכָאָל	2047 <sup>a</sup> ; 2048 <sup>a</sup>	מִכְּפָלָה	1959 <sup>b</sup>	
מִתְּוִינָאָת	1965 <sup>b</sup> ; 2488 <sup>b</sup> ; 2831 <sup>a</sup>	מִיכָה	2045 <sup>b</sup> ; 2046 <sup>a</sup>	מִכְּרָ	3072 <sup>a</sup>	
מִתְּוִינָאָת	2028 <sup>a</sup>	מִיכָהוּ	2045 <sup>b</sup> ; 2047 <sup>a</sup>	מִכְּרִי	2049 <sup>a</sup>	
מִתְּוִינָאָת	1934 <sup>a</sup>	מִיכָל	523 <sup>b</sup> ; 2048 <sup>a</sup>	מִכְּרִי	2016 <sup>b</sup>	
מִתְּוִינָאָת	2402 <sup>a</sup>	מִיָּם	2037 <sup>a</sup> ; 3072 <sup>b</sup> ; 3074 <sup>a</sup> ; 3075 <sup>a</sup>	מִכְּשׁוֹל	2179 <sup>b</sup> ; 2180 <sup>a</sup> ; 2625 <sup>b</sup> ; 2867 <sup>b</sup>	
מִתְּוִינָאָת	382 <sup>a</sup> ; 584 <sup>a</sup> ; 3070 <sup>b</sup>	מִיָּמֶן	2051 <sup>a</sup>	מִכְּשׁוֹל	2867 <sup>b</sup>	
מִתְּוִינָאָת	1966 <sup>b</sup>	מִיָּן	567 <sup>a, b</sup>	מִכְּשָׁלָה	2867 <sup>b</sup>	
מִתְּוִינָאָת	1966 <sup>a</sup>	מִיָּסָף	733 <sup>a</sup>	מִכְּתָם	2488 <sup>b</sup> ; 2491 <sup>b</sup>	
מִתְּוִינָאָת	} 2545 <sup>b</sup> ; 2558 <sup>a</sup>	מִיָּפְעָת	see מִיָּפְעָת	מִכְּתָשׁ	1969 <sup>a</sup> ; 2083 <sup>a</sup>	
מִתְּוִינָאָת			מִיָּשָׁא	} 2037 <sup>b</sup> ; 2038 <sup>a</sup>	מִלְ	see מִלְ
מִתְּוִינָאָת	483 <sup>a</sup>	מִיָּשָׁא			מִלָּא	} 1106 <sup>b</sup> ; 1148 <sup>a</sup> ; 1149 <sup>b</sup> ; 2438 <sup>b</sup> ; 2461 <sup>b</sup> ; 2743 <sup>a</sup>
מִתְּוִינָאָת	} 2319 <sup>a</sup> ; 2420 <sup>a</sup>	מִיָּשָׁאָל	2066 <sup>b</sup>	מִלָּא		
מִתְּוִינָאָת			מִיָּשׁוֹר	459 <sup>b</sup> ; 2017 <sup>a</sup> ; 2406 <sup>b</sup> ; 2407 <sup>a</sup> ; 2751 <sup>a</sup>	מִלָּא	
מִתְּוִינָאָת	1967 <sup>a</sup>	מִיָּשׁוֹר		מִלָּא	} 533 <sup>a</sup>	
מִתְּוִינָאָת	2049 <sup>a</sup>	מִיָּשׁוֹר		מִלּוֹ		
מִתְּוִינָאָת	474 <sup>a</sup>	מִיָּשׁוֹר	2038 <sup>a</sup>	מִלּוֹ		
מִתְּוִינָאָת	1364 <sup>b</sup> ; 2083 <sup>a</sup>	מִיָּשׁוֹר	2037 <sup>b</sup>	מִלּוֹ	see מִלּוֹ	
מִתְּוִינָאָת	2012 <sup>b</sup>	מִיָּשׁוֹר	2037 <sup>b</sup>	מִלּוֹ	704 <sup>a</sup>	
		מִיָּשׁוֹר	709 <sup>b</sup> ; 3098 <sup>b</sup>			

מְלֹאָה	704 <sup>a</sup> ; 2743 <sup>b</sup>	מְלִפְי־צָדֵק	58 <sup>a</sup> ; 2028 <sup>b</sup>	מְנַהֵה	1228 <sup>a</sup> ; 1857 <sup>a</sup> ; 2177 <sup>b</sup> ; 2442 <sup>a</sup> ; 2443 <sup>b</sup> ; 2539 <sup>a,b</sup> ; 2642 <sup>a</sup> ; 2644 <sup>a</sup> ; 2645 <sup>a</sup> ; 2652 <sup>a</sup> ; 2732 <sup>a</sup>	
מְלֹאָהָ	115 <sup>a</sup> ; 132 <sup>b</sup> ; 1253 <sup>b</sup> ; 2039 <sup>a</sup>	מְלִפְיָרִים	1971 <sup>a</sup>	מְנַהֵה	see מְנַהֵהָ	
מְלֹאָהָ	533 <sup>a</sup> ; 583 <sup>b</sup> ; 1279 <sup>a</sup> ; 2178 <sup>a</sup> ; 2514 <sup>a</sup> ; 2867 <sup>b</sup> ; 3105 <sup>b</sup>	מְלִפְי־שׁוֹרֵעַ	1971 <sup>a</sup> ; 2028 <sup>b</sup>	מְנַהֵהוֹת	2033 <sup>a</sup> ; see also הַמְנַהֵהוֹת	
מְלֹאָכִי	1969 <sup>b</sup>	מְלִמָּם	1971 <sup>a</sup>	מְנַהֵת	2031 <sup>a</sup>	
מְלִבָּן	522 <sup>a</sup>	מְלִכּוֹם	2074 <sup>b</sup>	מְנַהֵתִי	2033 <sup>a</sup> ; see also הַמְנַהֵתִי	
מְלִהָ	} 535 <sup>b</sup> ; 2411 <sup>a</sup>	מְלִכָּת	2513 <sup>b</sup> ; 2514 <sup>a</sup>	מְנִי	593 <sup>b</sup> ; 1152 <sup>a</sup> ; 2062 <sup>a</sup>	
מְלִהָ		מְלִכָּת	1325 <sup>b</sup>	מְנִי	see מֵן	
מְלִי	} see מְלֹאָ	מְלִי	2051 <sup>a</sup>	מְנַמְיִן	2057 <sup>a</sup>	
מְלִיאָ		} 2055 <sup>a, b</sup>	מְלַמֵּד	1248 <sup>b</sup> ; 2976 <sup>a</sup>	מְנַח	2062 <sup>a</sup>
מְלִיאָ	מְלַצֵּר		2030 <sup>a</sup> ; 2853 <sup>b</sup>	מְנַחָה	2321 <sup>a</sup>	
מְלִיחָ	} 2055 <sup>a, b</sup>	מְלַקוֹחַ	503 <sup>b</sup> ; 600 <sup>b</sup> ; 1572 <sup>a</sup> ; 2439 <sup>a</sup>	מְנַע	830 <sup>a</sup>	
מְלִיחָ		מְלַקוֹשׁ	2525 <sup>b</sup>	מְנַעוּל	} 1436 <sup>b</sup>	
מְלִיחָת	1122 <sup>b</sup> ; 2664 <sup>b</sup>	מְלַקָּח	} 2820 <sup>a</sup> ; 2994 <sup>a</sup>	מְנַעַל		2779 <sup>a</sup>
מְלִיחָתָ	} 491 <sup>b</sup> ; 1972 <sup>a</sup> ; 2029 <sup>b</sup>	מְלַקָּח		מְלַתְהָה	3049 <sup>a</sup>	מְנַעֵם
מְלִיכִי		מְלַתְעָה	600 <sup>b</sup> ; 1572 <sup>a</sup>	מְמַגְרָה	405 <sup>a</sup>	מְנַעֵנֵעַ
מְלוֹכָה	2624 <sup>b</sup>	מְמַרְבֵּן	} 2031 <sup>a</sup>	מְמַזְרֵד	413 <sup>b</sup>	
מְלוֹךְ	1470 <sup>a, b</sup>	מְמַרְבֵּן		2662 <sup>b</sup> ; 3072 <sup>a</sup>	מְמַלְכָה	2624 <sup>a, b</sup>
מְלוֹכָה	1470 <sup>a, b</sup> ; 1910 <sup>a</sup>	מְמַרְבֵּן	} 2031 <sup>a</sup>	מְמַסָּה	3086 <sup>b</sup>	
מְלוֹחֵי	1972 <sup>a</sup>	מְמַרְבֵּן		1973 <sup>a</sup>	מְמַשְׁרֵי	1980 <sup>b</sup>
מְלוֹחַ	2929 <sup>a</sup>	מְמַרְדֵּי	413 <sup>b</sup>	מְסָ	} 2919 <sup>b</sup> ; 3010 <sup>b</sup>	
מְלוֹחַ	729 <sup>b</sup> ; 1123 <sup>a</sup> ; 2524 <sup>b</sup> ; 2539 <sup>a, b</sup> ; 2624 <sup>a</sup> ; 2664 <sup>a</sup>	מְמַרְדֵּי	2662 <sup>b</sup> ; 3072 <sup>a</sup>	מְסָ		
מְלוֹחַ	2774 <sup>b</sup> ; 2775 <sup>a</sup>	מְמַלְכָה	2624 <sup>a, b</sup>	מְסָב	} 2898 <sup>a</sup>	
מְלוֹחָה	406 <sup>a</sup>	מְמַסָּה	3086 <sup>b</sup>	מְסָבוֹת		
מְלוֹחָהָ	3069 <sup>b</sup> ; 3072 <sup>a</sup>	מְמַרְאָ	1973 <sup>a</sup>	מְסָבָת		
מְלוֹט	820 <sup>b</sup>	מֵן	1982 <sup>a</sup>	מְסָבָתָ	503 <sup>b</sup> ; 669 <sup>b</sup>	
מְלוֹט	667 <sup>a</sup>	מֵן	} 2016 <sup>a</sup> ; 2411 <sup>a</sup>	מְסָבָרְדִין	2421 <sup>a</sup>	
מְלוֹטָה	2028 <sup>b</sup>	מְנִי		מֵן	מְסָה	2007 <sup>a</sup>
מְלוֹטָהָ	789 <sup>b</sup> ; 1110 <sup>a</sup> ; 2471 <sup>a</sup>	מְנִי	2097 <sup>b</sup>	מְסָהָ	3047 <sup>a</sup>	
מְלוֹצָה	704 <sup>b</sup> ; 1799 <sup>b</sup> ; 1968 <sup>a</sup> ; 2553 <sup>a</sup>	מֵן	} 2422 <sup>b</sup>	מְסָרְבָה	2974 <sup>b</sup>	
מְלוֹצָה	777 <sup>b</sup> ; 1254 <sup>b</sup> ; 1288 <sup>a</sup> ; 1325 <sup>b</sup> ; 1569 <sup>b</sup> ; 1587 <sup>b</sup> ; 1799 <sup>b</sup> ; 1808 <sup>a, b</sup> ; 1971 <sup>a, b</sup> ; 2029 <sup>b</sup> ; 2624 <sup>a</sup> ; 2758 <sup>b</sup> ; 3152 <sup>b</sup>	מְנָא		2032 <sup>a</sup>	מְסָרְחַר	3004 <sup>b</sup>
מְלוֹצָה	612 <sup>a</sup> ; 2074 <sup>a</sup>	מְנָה	see מְנָהָ	מְסָרְחַר	3086 <sup>b</sup>	
מְלוֹצָהָ	2051 <sup>a</sup>	מְנָה	723 <sup>b</sup>	מְסָרְחַר	1336 <sup>a</sup> ; 2889 <sup>a</sup>	
מְלוֹכָה	2513 <sup>b</sup> ; 2624 <sup>a</sup>	מְנָה	1981 <sup>a</sup> ; 2426 <sup>b</sup> ; 3078 <sup>b</sup>	מְסָרְבָה	1450 <sup>a</sup> ; 3047 <sup>a</sup>	
מְלִכּוֹת	} 2553 <sup>a</sup> ; 2624 <sup>a</sup>	מְנָהָ	829 <sup>b</sup>	מְסָרְבָהָ	2520 <sup>a</sup> ; 2863 <sup>a</sup> ; 3007 <sup>b</sup>	
מְלִכָּת		מְנָהָ	1983 <sup>b</sup>	מְנָהָ	301 <sup>a</sup> ; 585 <sup>a</sup> ; 2949 <sup>a</sup> ; 3075 <sup>b</sup>	
מְלִכָּתָ	1971 <sup>a</sup>	מְנָהָ	} 1977 <sup>a</sup> ; 2033 <sup>a</sup> ; 2453 <sup>b</sup> ; 2561 <sup>b</sup> ; 2732 <sup>a</sup> ; 2854 <sup>b</sup>	מְסָלוּל	3075 <sup>b</sup>	
מְלִכָּתָהָ	1971 <sup>a</sup>	מְנָהָ		מְסָמֵר	} 2111 <sup>a</sup>	
מְלִכָּתָהָ	1971 <sup>a</sup>	מְנָהָ	2545 <sup>b</sup>	מְסָמֵר		
מְלִכָּתָהָ	1971 <sup>a</sup>	מְנָהָ	417 <sup>a</sup>	מְסָמֵרָה	} 2111 <sup>a</sup>	
מְלִכָּתָהָ	1971 <sup>a</sup> ; 2028 <sup>b</sup>	מְנָהָ	552 <sup>b</sup> ; 553 <sup>a</sup>	מְסָמֵרָה		
מְלִכָּתָהָ		מְנָהָ		מְשַׁמְרָה		

מָסַס	1086 <sup>b</sup>	מִצְכָּחַי	1945 <sup>a</sup>	מִשְׁתַּח	1793 <sup>b</sup>	
מִסְעָר	585 <sup>a</sup> ; 2398 <sup>b</sup>	מִעַל	746 <sup>b</sup> ; 1141 <sup>a</sup>	מִשְׁתָּן	776 <sup>b</sup> ; 777 <sup>a</sup> ; 1436 <sup>b</sup>	
מִסְפּוֹא	2469 <sup>b</sup>	מִעַל	1273 <sup>a</sup>	מִזְן	} 588 <sup>b</sup>	
מִסְפָּחָה	1793 <sup>a</sup>	מִעֲלָה	89 <sup>a</sup> ; 266 <sup>b</sup> ; 606 <sup>b</sup> ; 1273 <sup>a</sup> ; 1310 <sup>b</sup> ; 1376 <sup>b</sup> ; 1392 <sup>b</sup> ; 1935 <sup>b</sup> ; 2185 <sup>b</sup> ; 2703 <sup>b</sup> ; 3153 <sup>a</sup>	מִזָּא		1221 <sup>a</sup>
מִסְפָּר	1467 <sup>a</sup> ; 2067 <sup>a</sup> ; 2904 <sup>a</sup>	מִעֲלָה	519 <sup>a</sup> ; 819 <sup>a,b</sup> ; 841 <sup>b</sup> ; 2863 <sup>a</sup>	מִזָּא	see מִזָּא	
מִסְפָּרָה	2067 <sup>a</sup>	מִעֲלָה	} 38 <sup>a</sup> ; 89 <sup>a</sup> ; 2703 <sup>b</sup>	מִצָּב	1392 <sup>b</sup> ; 3071 <sup>a</sup>	
מִסָּר	382 <sup>a</sup>	עֲקָרָבִים			מִצָּב	1136 <sup>b</sup> ; 1392 <sup>b</sup> ; 2398 <sup>b</sup> ; 2407 <sup>b</sup>
מִסְרֹחַ	see מוֹסְרָה	מִצְמֵד	2180 <sup>b</sup>	מִצְבָּה	138 <sup>b</sup> ; 331 <sup>a</sup> ; 444 <sup>a</sup> ; 927 <sup>b</sup> ; 1386 <sup>a</sup> ; 1390 <sup>b</sup> ; 1450 <sup>a</sup> ; 1452 <sup>a</sup> ; 1454 <sup>a,b</sup> ; 1533 <sup>a</sup> ; 1808 <sup>b</sup> ; 2177 <sup>b</sup> ; 2227 <sup>a</sup> ; 2234 <sup>a</sup> ; 2398 <sup>b</sup> ; 3154 <sup>b</sup>	
מִסְרָה	2555 <sup>a</sup>	מִצָּן	943 <sup>a</sup> ; 1484 <sup>a</sup>	מִצָּד	} 830 <sup>a</sup>	
מִעֲבָה	667 <sup>a</sup> ; 2000 <sup>a</sup>	מִצְנָה	1150 <sup>b</sup>	מִצְדָּה		
מִעֲבָר	} 1127 <sup>a</sup> ; 2255 <sup>b</sup>	מִעֲנָה	see מִעֲנָה	מִצְדָּה	see מִצְדָּה	
מִעֲבָרָה			מִצָּץ	1946 <sup>a</sup>	מִצָּה	941 <sup>a</sup>
מִעֲגָל	} 580 <sup>b</sup> ; 1334 <sup>a</sup> ; 3070 <sup>b</sup> ; 3075 <sup>b</sup>	מִצָּד	2994 <sup>b</sup> ; 2998 <sup>b</sup>	מִצָּה	515 <sup>b</sup> ; 517 <sup>a</sup> ; 1122 <sup>a</sup> ; 1862 <sup>b</sup> ; 2256 <sup>a,b</sup>	
מִעֲגָלָה			מִצָּר	341 <sup>b</sup>	מִצְדָּה	} 528 <sup>a</sup>
מִצְרֵי	1945 <sup>b</sup>	מִצָּר	2467 <sup>b</sup>	מִצְדָּה		
מִצְרָה	1945 <sup>b</sup>	מִצְרָב	} 888 <sup>b</sup> ; 1945 <sup>b</sup> ; 1995 <sup>b</sup> ; 2035 <sup>a</sup> ; 3002 <sup>a</sup> ; 3063 <sup>b</sup> ; 3082 <sup>a</sup>	מִצְדָּה		
מִצְדָּן	312 <sup>a</sup> ; 314 <sup>b</sup> ; 777 <sup>a</sup> ; 820 <sup>a</sup> ; 1468 <sup>a</sup>	מִצְרָה		1945 <sup>b</sup> ; 2013 <sup>a</sup>	מִצְדָּה	see מִצְדָּה
מִצְדָּקָה	} 820 <sup>a</sup> ; 1468 <sup>a</sup>	מִצְרָה	585 <sup>a</sup> ; 593 <sup>a</sup> ; 829 <sup>b</sup> ; 1444 <sup>a</sup> ; 2016 <sup>a</sup>	מִצָּה	941 <sup>a</sup>	
מִצְדָּר		2012 <sup>b</sup>	מִצְרָה	254 <sup>b</sup> ; 2530 <sup>a</sup>	מִצָּה	515 <sup>b</sup> ; 517 <sup>a</sup> ; 1122 <sup>a</sup> ; 1862 <sup>b</sup> ; 2256 <sup>a,b</sup>
מִצְהָ	432 <sup>b</sup> ; 492 <sup>a</sup> ; 511 <sup>a</sup> ; 2838 <sup>a</sup>	מִצְרָת	1945 <sup>b</sup>	מִצְדָּה		
מִצְהָ	511 <sup>a</sup>	מִצְטָה	533 <sup>a</sup> ; 817 <sup>a</sup> ; 2196 <sup>b</sup> ; 3072 <sup>a</sup> ; 3105 <sup>b</sup>	מִצְדָּה		
מִצְוֹז	} 1127 <sup>a</sup> ; 1136 <sup>b</sup> ; 2012 <sup>b</sup>	מִצְטָה	114 <sup>a</sup> ; 1945 <sup>b</sup>	מִצְדָּה		
מִצְוֹז			מִצְטָה	348 <sup>a</sup> ; 1945 <sup>b</sup>	מִצְדָּה	1136 <sup>b</sup> ; 1140 <sup>a</sup>
מִצְוֹז			מִצְטָה	2905 <sup>b</sup> ; 2987 <sup>b</sup>	מִצְדָּה	679 <sup>b</sup> ; 1852 <sup>a,b</sup> ; 2201 <sup>a</sup> ; 2434 <sup>b</sup>
מִצְוֹז	1984 <sup>a</sup>	מִצְטָה	2030 <sup>b</sup>	מִצְדָּה	} 510 <sup>b</sup>	
מִצְוֹן	} 829 <sup>b</sup> ; 1313 <sup>a</sup> ; 1984 <sup>a</sup>	מִצְטָה	see מִפְּבִשָּׁח	מִצְדָּה		
מִצְוֹן			מִצְטָה	1986 <sup>a</sup>	מִצְדָּה	
מִצְוֹנָה	} 829 <sup>b</sup>	מִפְּבִשָּׁח	2033 <sup>b</sup>	מִצְדָּה		
מִצְוֹנָה			מִפְּבִשָּׁח	2033 <sup>b</sup>	מִצְדָּה	2398 <sup>b</sup>
מִצְוֹנִי	} 2028 <sup>a</sup>	מִפְּבִשָּׁח	2094 <sup>a</sup>	מִצְדָּה	} 528 <sup>a</sup> ; 1106 <sup>b</sup> ; 1136 <sup>b</sup> ; 2595 <sup>a</sup> ; 2786 <sup>a,b</sup> ; 2787 <sup>a</sup>	
מִצְוֹנִי			מִפְּבִשָּׁח	2012 <sup>b</sup>		מִצְדָּה
מִצְוֹנִי	2033 <sup>b</sup>	מִפְּבִשָּׁח	1117 <sup>b</sup>	מִצְדָּה	} 1106 <sup>b</sup> ; 1136 <sup>b</sup>	
מִצְוֹז	} see מִצְוֹז	מִפְּבִשָּׁח	576 <sup>b</sup> ; 2625 <sup>b</sup>	מִצְדָּה		
מִצְוֹז			מִפְּבִשָּׁח	342 <sup>a</sup>	מִצְדָּה	526 <sup>b</sup> ; 1127 <sup>b</sup>
מִצְוֹז	1946 <sup>a</sup>	מִפְּבִשָּׁח	1325 <sup>b</sup> ; 2062 <sup>b</sup>	מִצְדָּה	254 <sup>a</sup>	
מִצְוֹזָה	1984 <sup>a</sup>	מִפְּבִשָּׁח	514 <sup>b</sup>	מִצְדָּה	432 <sup>a</sup> ; 510 <sup>b</sup>	
מִצְוֹזָה	1945 <sup>b</sup>	מִפְּבִשָּׁח	2129 <sup>a</sup>	מִצְדָּה	2095 <sup>a</sup> ; 2097 <sup>a</sup> ; 2101 <sup>a</sup>	
מִצְוֹזָה	669 <sup>a</sup> ; 670 <sup>a</sup> ; 876 <sup>b</sup>	מִפְּבִשָּׁח	see מוֹפְתָה	מִצְדָּה	841 <sup>a</sup> ; 1080 <sup>a</sup>	
מִצְוֹזָה	see מִצְהָ	מִפְּבִשָּׁח		מִצְדָּה	422 <sup>a</sup>	
מִצְוֹזָה	} 658 <sup>a</sup> ; 3081 <sup>a</sup>	מִפְּבִשָּׁח				
מִצְוֹזָה			מִפְּבִשָּׁח			
מִצְוֹזָה	see מִצְוֹזָה	מִפְּבִשָּׁח				
מִצְוֹזָה	} 1945 <sup>a</sup>	מִפְּבִשָּׁח				
מִצְוֹזָה			מִפְּבִשָּׁח			

מַצְעָר 2068<sup>a</sup>  
 מַצְפָּה 2068<sup>b</sup>; 2069<sup>a</sup>; 3074<sup>a</sup>  
 מַצְפָּה 1350<sup>b</sup>; 2068<sup>b</sup>; 2127<sup>a</sup>  
 מַצְפּוֹן 1389<sup>a</sup>  
 מַצָּק see מַצְוִק  
 מַצְקָה see מַצְוִקָה  
 מַצַּר 2207<sup>a</sup>; 2864<sup>a</sup>  
 מַצְרָה see מַצְרִיחַ  
 מַצְרִים 424<sup>a</sup>; 906<sup>a</sup>; 1324<sup>a</sup>;  
 1826<sup>a</sup>; 2069<sup>a</sup>;  
 2145<sup>b</sup>; 3003<sup>a</sup>  
 מַק 2624<sup>a</sup>  
 מַקְבָּה 1946<sup>b</sup>; 2998<sup>b</sup>  
 מַקְבָּח 1325<sup>b</sup>; 1948<sup>a</sup>  
 מַקְדָּה 1969<sup>a</sup>  
 מַקְדֵּשׁ } 326<sup>a</sup>; 594<sup>b</sup>; 2686<sup>b</sup>  
 מַקְדֵּשׁ }  
 מַקְהֵלָה 1969<sup>a</sup>  
 מַקְנָה } 2419<sup>b</sup>; 2420<sup>a</sup>  
 מַקְנָה }  
 מַקְנָא }  
 מַקְנָה 2419<sup>b</sup>; 2561<sup>a</sup>  
 מַקּוּם }  
 מַקָּם } 444<sup>a</sup>; 724<sup>a</sup>; 1417<sup>b</sup>;  
 1942<sup>b</sup>; 2210<sup>a</sup>;  
 מַקּוּמָה } 2402<sup>a</sup>; 2743<sup>b</sup>  
 מַקְמָה }  
 מַקּוּר } 658<sup>a</sup>; 1542<sup>b</sup>; 3081<sup>b</sup>;  
 מַקָּר } 3082<sup>a</sup>  
 מַקְתָּה 3072<sup>a</sup>  
 מַקְטִירָה } 587<sup>b</sup>; 588<sup>a</sup>  
 מַקְטִירָתָה }  
 מַקְל } 1335<sup>b</sup>; 2596<sup>b</sup>; 2847<sup>b</sup>  
 מַקְלָה }  
 מַקְלוֹת 2051<sup>a</sup>  
 מַקְלָט 2545<sup>b</sup>  
 מַקְלַעַת 581<sup>b</sup>; 1109<sup>b</sup>  
 מַקָּם } see מַקּוּם  
 מַקְמָה }  
 מַקְנָה } 583<sup>b</sup>; 584<sup>a</sup>  
 מַקְנָה }  
 מַקְנִירָה 2051<sup>a</sup>  
 מַקְצָ 1968<sup>a</sup>  
 מַקְצוּעַ } 721<sup>b</sup>; 2998<sup>b</sup>  
 מַקְצַע }  
 מַקְצָה }  
 מַקָּק 704<sup>b</sup>; 2399<sup>b</sup>  
 מַקָּר see מַקּוּר  
 מַקְרָא 701<sup>a</sup>; 708<sup>a</sup>; 2534<sup>a</sup>;  
 2911<sup>a</sup>

מַקְרָה 593<sup>a</sup>; 1041<sup>a</sup>; 1336<sup>b</sup>  
 מַקְשׁ see מוֹקֵשׁ  
 מַקְשָׁה 765<sup>b</sup>  
 מַר } 483<sup>b</sup>; 588<sup>b</sup>; 1354<sup>a</sup>;  
 מַרְה } 2000<sup>a</sup>  
 מַר } 2102<sup>b</sup>  
 מוֹר }  
 מַרְא 1919<sup>a</sup>  
 מַרְא see מוֹרְהַ  
 מַרְאָדָּ } 2036<sup>b</sup>  
 מַרְאָדָּן }  
 מַרְאָה 207<sup>b</sup>; 208<sup>b</sup>; 724<sup>a</sup>;  
 1136<sup>a</sup>; 1278<sup>b</sup>;  
 1981<sup>b</sup>; 2264<sup>b</sup>;  
 2581<sup>a, b</sup>  
 מַרְאָה 1234<sup>a</sup>; 2581<sup>a</sup>; 3057<sup>b</sup>  
 מַרְאָה 760<sup>b</sup>  
 מַרְאוֹן see שְׁמֵרוֹן מַרְאוֹן  
 מַרְאִישָׁה } 1985<sup>a</sup>  
 מַרְשָׁה }  
 מַרְאִישָׁה 1348<sup>a</sup>; 2454<sup>b</sup>  
 מַרְבֵּד 2909<sup>a</sup>  
 מַרְבֵּץ 723<sup>b</sup>  
 מַרְבֵּק 542<sup>b</sup>; 2847<sup>b</sup>  
 מַרְג see מוֹרְגַ  
 מַרְגָּעָה 2545<sup>b</sup>  
 מַרְד 313<sup>a, b</sup>  
 מַרְד 2036<sup>a</sup>  
 מַרְדָּ 2036<sup>b</sup>  
 מַרְדִּי 2081<sup>b</sup>  
 מַרְה 854<sup>b</sup>; 1125<sup>a</sup>; 1306<sup>a</sup>;  
 1984<sup>b</sup>; 2486<sup>b</sup>  
 מַרְה see מוֹרְהַ  
 מַרוֹז 2037<sup>b</sup>  
 מַרוֹחַ 523<sup>a</sup>  
 מַרוֹם 849<sup>a</sup>; 1369<sup>a</sup>; 1390<sup>a</sup>  
 מַרוֹם 2037<sup>a</sup>  
 מַרוֹץ 2523<sup>b</sup>  
 מַרוֹר see מוֹר  
 מַרוֹרָה see מוֹרְהַ  
 מַרוֹת 1996<sup>a</sup>  
 מַרְח 2408<sup>a</sup>  
 מַרְחָק see בֵּית הַמַּרְחָק  
 מַרְט 2295<sup>a</sup>  
 מַרִי 583<sup>b</sup>  
 מַרְיב־בַּעַל 2036<sup>b</sup>  
 מַרְיבָה 1153<sup>b</sup>; 2007<sup>a</sup>; 2486<sup>b</sup>  
 מַרְיב־בַּעַל 2036<sup>b</sup>  
 מַרְיָה see מוֹרְיָה

מַרְיָם 2001<sup>a</sup>; 2066<sup>a</sup>  
 מַרְכָּב 595<sup>a</sup>; 2658<sup>b</sup>  
 מַרְכָּבָה 595<sup>a</sup>; 596<sup>b</sup>  
 מַרְפֵּלָה 2035<sup>a</sup>; 3002<sup>a</sup>  
 מַרְמָה 815<sup>b</sup>; 1105<sup>a</sup>; 1309<sup>a</sup>;  
 2066<sup>a</sup>; 2868<sup>a</sup>  
 מַרְמוֹת 2036<sup>a</sup>  
 מַרְנָחַר 2037<sup>a</sup>  
 מַרְסָּא 1999<sup>b</sup>  
 מַרְעִיחַ 584<sup>a</sup>  
 מַרְעִלָה 1984<sup>b</sup>  
 מַרְפֵּא 766<sup>b</sup>; 767<sup>a</sup>; 1349<sup>b</sup>;  
 1350<sup>a</sup>  
 מַרְפֵּשׁ 1141<sup>b</sup>  
 מַרְצָ 1306<sup>b</sup>  
 מַרְצַע 341<sup>a</sup>  
 מַרְק 525<sup>a</sup>  
 מַרְק 525<sup>a</sup>  
 מַרְקָה 2183<sup>a</sup>  
 מַרְר 483<sup>b</sup>; 612<sup>b</sup>; 1306<sup>a</sup>  
 מַרְר } 483<sup>b</sup>; 484<sup>a</sup>  
 מַרְרוֹר }  
 מַרְרָה }  
 מַרְרָה } 483<sup>b</sup>; 1167<sup>a</sup>  
 מַרְרוֹהַ }  
 מַרְרִי 2034<sup>b</sup>; 2035<sup>a</sup>  
 מַרְשָׁה see מַרְאִישָׁה  
 מַרְתִּים 2035<sup>a</sup>  
 מַשׁ 2006<sup>b</sup>  
 מַשָּׂא see מַרְשָׂא  
 מַשָּׂא 528<sup>b</sup>; 1488<sup>b</sup>; 1559<sup>b</sup>;  
 2007<sup>a</sup>; 2198<sup>b</sup>;  
 2473<sup>a</sup>; 2581<sup>b</sup>;  
 2919<sup>b</sup>; 2942<sup>b</sup>  
 מַשָּׂא 1049<sup>b</sup>; 3041<sup>a</sup>  
 מַשָּׂאֵל 2066<sup>b</sup>  
 מַשָּׂאֵלָה 2358<sup>a</sup>  
 מַשָּׂאָה 528<sup>b</sup>; 674<sup>a</sup>; 1117<sup>b</sup>;  
 1228<sup>b</sup>; 2039<sup>a</sup>  
 מַשָּׁב see מוֹשָׁב  
 מַשָּׁבָה see מוֹשָׁבָה  
 מַשָּׁבָה 2204<sup>b</sup>  
 מַשָּׁבָב 1136<sup>b</sup>; 1139<sup>b</sup>; 1140<sup>a</sup>  
 מַשָּׁבָב 2066<sup>b</sup>  
 מַשָּׂה 2790<sup>b</sup>  
 מַשָּׂה 1977<sup>a</sup>; 2083<sup>b</sup>  
 מַשָּׂה 741<sup>a</sup>  
 מַשׁוּבָב 2038<sup>b</sup>

מְשֻׁבָּה } 376<sup>b</sup>  
 מְשֻׁבָּה }  
 מְשֻׁבָּה 970<sup>b</sup>; 1941<sup>b</sup>  
 מְשֻׁבָּה } 1366<sup>b</sup>  
 מְשֻׁבָּה }  
 מְשֻׁבָּה 2016<sup>a</sup>  
 מְשֻׁשׁ 1755<sup>a</sup>  
 מְשֻׁח 138<sup>a</sup>; 2208<sup>a</sup>  
 מְשֻׁח 2181<sup>b</sup>; 2183<sup>b</sup>  
 מְשֻׁחָה } 2183<sup>a</sup>; 2186<sup>a</sup>  
 מְשֻׁחָה }  
 מְשֻׁחִית 722<sup>b</sup>; 2186<sup>a</sup>  
 מְשֻׁחֶה 2082<sup>b</sup>  
 מְשֻׁחָת } 722<sup>b</sup>  
 מְשֻׁחָת }  
 מְשֻׁי 2790<sup>b</sup>; 2791<sup>a</sup>  
 מְשֻׁי see מְשֻׁי  
 מְשֻׁיבָאֵל 2038<sup>b</sup>  
 מְשֻׁיח 136<sup>b</sup>; 981<sup>b</sup>; 1411<sup>a</sup>;  
 1626<sup>a</sup>; 2039<sup>a, b</sup>;  
 2441<sup>b</sup>  
 מְשֻׁיָּה 382<sup>a</sup>; 818<sup>a</sup>; 1126<sup>b</sup>;  
 1335<sup>a</sup>; 2459<sup>a</sup>  
 מְשֻׁיָּה 2006<sup>b</sup>; 2038<sup>a</sup>  
 מְשֻׁיָּב 422<sup>a, b</sup>  
 מְשֻׁיָּה see מְשֻׁיָּה  
 מְשֻׁיָּל 2488<sup>b</sup>; 2491<sup>b</sup>  
 מְשֻׁיָּם see שְׂכָם  
 מְשֻׁיָּת 592<sup>a</sup>; 1452<sup>b</sup>; 1455<sup>b</sup>;  
 2394<sup>b</sup>; 3096<sup>b</sup>  
 מְשֻׁיָּן 1313<sup>a</sup>; 1817<sup>a</sup>; 2887<sup>b</sup>;  
 2888<sup>b</sup>; 2889<sup>b</sup>;  
 2948<sup>a</sup>  
 מְשֻׁיָּת 3063<sup>a</sup>  
 מְשֻׁל 694<sup>b</sup>; 1289<sup>b</sup>; 2469<sup>b</sup>;  
 2470<sup>a</sup>; 2471<sup>b</sup>;  
 2625<sup>b</sup>  
 מְשֻׁל 379<sup>a</sup>; 535<sup>b</sup>; 789<sup>b</sup>;  
 1170<sup>a</sup>; 1681<sup>a</sup>;  
 1687<sup>b</sup>; 2006<sup>b</sup>;  
 2414<sup>a</sup>; 2474<sup>a, b</sup>;  
 2475<sup>a, b</sup>; 2476<sup>a</sup>;  
 2806<sup>b</sup>  
 מְשֻׁל 535<sup>b</sup>  
 מְשֻׁלוֹשׁ see שְׁלוֹשׁ  
 מְשֻׁלָּם 2038<sup>b</sup>  
 מְשֻׁלָּמֹת 2038<sup>b</sup>  
 מְשֻׁלָּמִיָּה } 2038<sup>b</sup>  
 מְשֻׁלָּמִיָּה }  
 מְשֻׁלָּמֹת 2039<sup>a</sup>  
 מְשֻׁלָּמֵן 1101<sup>b</sup>  
 מְשֻׁלָּמָה 2066<sup>b</sup>

מְשֻׁמֵּע 2066<sup>b</sup>  
 מְשֻׁמֵּעַת 1307<sup>b</sup>  
 מְשֻׁמֵּר 1307<sup>b</sup>; 2180<sup>b</sup>;  
 2465<sup>a, b</sup>; 3074<sup>a</sup>  
 מְשֻׁמֵּרַת 97<sup>b</sup>; 594<sup>a</sup>; 2201<sup>a</sup>;  
 3074<sup>a</sup>  
 מְשֻׁנָּה 519<sup>a</sup>; 674<sup>a</sup>; 2066<sup>b</sup>;  
 2200<sup>b</sup>  
 מְשֻׁסָּה 503<sup>b</sup>  
 מְשֻׁעָם 2066<sup>b</sup>  
 מְשֻׁסָּהָה 1094<sup>b</sup>; 1101<sup>a</sup>;  
 1799<sup>a</sup>; 2554<sup>a</sup>;  
 2556<sup>b</sup>; 2701<sup>a</sup>  
 מְשֻׁסָּט 518<sup>a</sup>; 730<sup>a</sup>; 745<sup>b</sup>;  
 834<sup>a</sup>; 883<sup>b</sup>; 1098<sup>b</sup>;  
 1136<sup>a</sup>; 1256<sup>b</sup>;  
 1852<sup>a, b</sup>; 1858<sup>a</sup>;  
 1982<sup>b</sup>; 1983<sup>a</sup>;  
 2016<sup>a</sup>; 2201<sup>a</sup>;  
 2591<sup>a</sup>  
 מְשֻׁסָּת 2757<sup>b</sup>  
 מְשֻׁק 518<sup>b</sup>; 929<sup>b</sup>; 2853<sup>b</sup>  
 מְשֻׁקָה 533<sup>a</sup>; 766<sup>b</sup>  
 מְשֻׁקֹל 3079<sup>a</sup>  
 מְשֻׁקֹה 1435<sup>b</sup>  
 מְשֻׁקֶל 3079<sup>a</sup>  
 מְשֻׁקֶלַת } 2999<sup>a</sup>  
 מְשֻׁקֶלַת }  
 מְשֻׁרָּה 3086<sup>b</sup>  
 מְשֻׁרָּקִי 2095<sup>a</sup>; 2097<sup>a</sup>  
 מְשֻׁרָּעִי 2067<sup>a</sup>  
 מְשֻׁרָּפֹת } 2067<sup>a</sup>  
 מִים }  
 מְשֻׁרָּקָה 2007<sup>a</sup>  
 מְשֻׁרָּת 2237<sup>a</sup>  
 מְשֻׁשׁ 1105<sup>a</sup>  
 מְשֻׁתָּה 384<sup>b</sup>  
 מֵת 408<sup>a</sup>; 2337<sup>a</sup>  
 מְתָבֵן 2866<sup>b</sup>  
 מְתָג 482<sup>b</sup>  
 מְתָג הָאֲמָה 2045<sup>a</sup>  
 מְתָהֲשָׂאֵל 2045<sup>a</sup>  
 מְתָהֲשָׁלַח 2045<sup>a</sup>  
 מְתָיִם see מֵת  
 מְתָפְנֵת 695<sup>b</sup>; 2016<sup>a</sup>; 2904<sup>a</sup>  
 מְתָקָה 600<sup>b</sup>  
 מְתָן see מְתָנִי  
 מְתָן 868<sup>a</sup>; 1917<sup>a, b</sup>  
 מְתָן 171<sup>b</sup>; 872<sup>b</sup>; 2008<sup>a</sup>  
 מְתָנָה 1228<sup>a</sup>; 2008<sup>b</sup>  
 מְתָנִי 2067<sup>b</sup>

מְתָנִי 2009<sup>b</sup>  
 מְתָנָה } 2008<sup>b</sup>; 3141<sup>a</sup>  
 מְתָנָה }  
 מְתָנִים see מְתָן  
 מְתָקָה 2067<sup>b</sup>  
 מְתָרָת 2067<sup>b</sup>  
 מְתָתָה 2009<sup>a</sup>  
 מְתָתָה } 2012<sup>a, b</sup>  
 מְתָתָה }  
 נ  
 נָא 1248<sup>a</sup>  
 נָא 2153<sup>b</sup>  
 נָאֵד 509<sup>b</sup>; 526<sup>b</sup>; 1249<sup>b</sup>;  
 נָאֵד } 2052<sup>a</sup>; 2814<sup>a</sup>;  
 נָאֵד } 2923<sup>b</sup>; 3088<sup>a</sup>  
 נָאֵדָה }  
 נָאָה 421<sup>b</sup>  
 נָאָה 421<sup>b</sup>; 678<sup>b</sup>  
 נָאָם 2473<sup>a</sup>  
 נָאָם 1559<sup>b</sup>; 2578<sup>b</sup>; 2581<sup>b</sup>  
 נָאָם 517<sup>b</sup>  
 נָאָץ 485<sup>b</sup>  
 נָאָק 1306<sup>b</sup>; 1307<sup>a</sup>  
 נָאָקָה 1306<sup>b</sup>  
 נָב 2153<sup>b</sup>  
 נָבָא 2921<sup>b</sup>  
 נָבֵב 1404<sup>b</sup>  
 נָבו 2126<sup>b</sup>; 2127<sup>a</sup>  
 נָבוּאָה 405<sup>b</sup>  
 נָבוּרָאֵדָן 2129<sup>a</sup>  
 נָבוּרָאֵדָר } 2127<sup>b</sup>  
 נָבוּרָאֵדָר }  
 נָבוּרָאֵדָר }  
 נָבוּרָאֵדָר }  
 נָבוּרָאֵדָר }  
 נָבוּרָאֵדָן 2129<sup>a</sup>  
 נָבוּת 2108<sup>a</sup>  
 נָבוּתָה 2141<sup>a</sup>  
 נָבֻט 2126<sup>b</sup>  
 נָבִיא 125<sup>a</sup>; 555<sup>a</sup>; 783<sup>b</sup>;  
 1152<sup>a</sup>; 1408<sup>a</sup>;  
 1447<sup>b</sup>; 2183<sup>b</sup>;  
 2459<sup>b</sup>; 2460<sup>a</sup>;  
 2461<sup>b</sup>; 2578<sup>a</sup>;  
 2581<sup>a</sup>  
 נָבִיאָה 2466<sup>b</sup>  
 נָבוּתָה } 2126<sup>b</sup>  
 נָבוּתָה }  
 נָבֻל 1086<sup>a</sup>; 2156<sup>b</sup>; 3098<sup>b</sup>

נָבֵל } 509<sup>b</sup>; 660<sup>a</sup>; 1117<sup>b</sup>;  
 1942<sup>a</sup>; 2095<sup>a</sup>;  
 נָבֵל } 2097<sup>a</sup>; 2101<sup>a</sup>;  
 2401<sup>b</sup>; 2814<sup>a</sup>;  
 3049<sup>a</sup>; 3051<sup>a</sup>;  
 3088<sup>a</sup>  
 נָבֵל 1124<sup>a, b</sup>; 2107<sup>a</sup>  
 נָבֵלָה 491<sup>b</sup>; 576<sup>b</sup>; 722<sup>b</sup>  
 נָבֵלָה 1124<sup>a, b</sup>  
 נָבֵלֹת 1880<sup>b</sup>  
 נָבֵלֹת 2126<sup>b</sup>  
 נָבֵרֶשֶׁתָא 552<sup>b</sup>  
 נָבֶשֶׁן 2141<sup>a</sup>  
 נָבֵב 724<sup>b</sup>; 2130<sup>a</sup>; 2210<sup>a</sup>;  
 2538<sup>a, b</sup>  
 נָבֵר 459<sup>a</sup>; 588<sup>b</sup>; 2458<sup>b</sup>;  
 2550<sup>b</sup>  
 נָבֵר 2438<sup>a</sup>  
 נָבֵה 952<sup>b</sup>  
 נָבֵה 2082<sup>b</sup>; 2154<sup>b</sup>; 2773<sup>b</sup>  
 נָבֵה 1279<sup>b</sup>  
 נָבֵר } 569<sup>a</sup>; 606<sup>a</sup>; 2040<sup>a</sup>;  
 2443<sup>b</sup>; 2454<sup>a</sup>;  
 נָבֵר } 2626<sup>a</sup>  
 נָבֵרָה } 2488<sup>b</sup>  
 נָבֵרָה }  
 נָבֵן 2029<sup>b</sup>; 2813<sup>b</sup>  
 נָבֵע 522<sup>b</sup>; 1336<sup>b</sup>; 2403<sup>a</sup>  
 נָבֵע 2402<sup>a</sup>; 2403<sup>a</sup>;  
 2836<sup>a, b</sup>  
 נָבֵה 2403<sup>a</sup>  
 נָבֵה 2403<sup>a</sup>  
 נָבֵר 2756<sup>b</sup>  
 נָבֵשׁ 1049<sup>a, b</sup>; 2917<sup>a</sup>  
 נָבֵשׁ 522<sup>b</sup>; 1338<sup>a</sup>  
 נָבֵ 1350<sup>b</sup>  
 נָבֵ 1145<sup>a</sup>  
 נָבֵ 1145<sup>a</sup>  
 נָבֵ 2108<sup>b</sup>  
 נָבֵהָ 1145<sup>a</sup>; 2639<sup>a, b</sup>;  
 2644<sup>b</sup>; 3058<sup>a</sup>  
 נָבֵרָה 2129<sup>b</sup>  
 נָבֵר 2124<sup>a</sup>  
 נָבֵה } 1050<sup>b</sup>  
 נָבֵהָ }  
 נָבֵה 1228<sup>b</sup>  
 נָבֵה 160<sup>b</sup>; 1110<sup>b</sup>; 2721<sup>b</sup>;  
 3035<sup>b</sup>  
 נָבֵת 695<sup>b</sup>; 2204<sup>b</sup>  
 נָבֵיב 1881<sup>a</sup>; 2154<sup>a</sup>; 2454<sup>a</sup>  
 נָבֵן 1228<sup>b</sup>  
 נָבֵה 492<sup>a</sup>

נָבֵר } 2639<sup>a, b</sup>; 2644<sup>b</sup>;  
 נָבֵר } 2805<sup>a</sup>; 3058<sup>a</sup>  
 נָבֵג 580<sup>b</sup>  
 נָבֵי 869<sup>a</sup>; 1307<sup>a</sup>  
 נָבֵהָ 869<sup>a</sup>  
 נָבֵלָל } 532<sup>a</sup>; 2108<sup>b</sup>  
 נָבֵלָל }  
 נָבֵק 514<sup>b</sup>  
 נָבֵר 2524<sup>a, b</sup>  
 נָבֵר 2595<sup>a</sup>; 2866<sup>b</sup>  
 נָבֵר 523<sup>b</sup>; 524<sup>a, b</sup>; 552<sup>b</sup>;  
 897<sup>b</sup>; 1120<sup>a</sup>;  
 2145<sup>b</sup>; 2595<sup>a</sup>;  
 2866<sup>b</sup>  
 נָבֵא 851<sup>a</sup>  
 נָבֵב 2108<sup>a</sup>  
 נָבֵבֵר 2126<sup>b</sup>; 2154<sup>a</sup>  
 נָבֵר 1221<sup>a</sup>; 2402<sup>a</sup>; 3044<sup>a</sup>  
 נָבֵר } 2154<sup>b</sup>  
 נָבֵר }  
 נָבֵהָ } 1313<sup>a</sup>; 2757<sup>b</sup>  
 נָבֵהָ }  
 נָבֵה 699<sup>a</sup>; 2117<sup>a</sup>  
 נָבֵהָ } 2153<sup>a</sup>; 2561<sup>b</sup>  
 נָבֵהָ }  
 נָבֵהָ 2154<sup>b</sup>  
 נָבֵהָ 2111<sup>a</sup>; 2462<sup>a</sup>  
 נָבֵן } 2155<sup>a</sup>; 2170<sup>a</sup>  
 נָבֵן }  
 נָבֵס 1584<sup>a</sup>  
 נָבֵע 1148<sup>a</sup>  
 נָבֵעֵהָ 2153<sup>a</sup>  
 נָבֵהָ } 1104<sup>b</sup>  
 נָבֵהָ }  
 נָבֵר 1112<sup>a</sup>  
 נָבֵה 2846<sup>b</sup>  
 נָבֵר } 2124<sup>a</sup>; 3050<sup>a</sup>  
 נָבֵר }  
 נָבֵל 1120<sup>a</sup>; 2867<sup>a</sup>  
 נָבֵס 1675<sup>b</sup>; 2156<sup>a</sup>; 2594<sup>b</sup>  
 נָבֵק 943<sup>b</sup>  
 נָבֵק 778<sup>a</sup>  
 נָבֵר 703<sup>a</sup>; 762<sup>a</sup>; 2721<sup>b</sup>  
 נָבֵר } 703<sup>a</sup>; 762<sup>a</sup>; 763<sup>a</sup>;  
 נָבֵר } 1801<sup>a</sup>  
 נָבֵרֵי 2109<sup>b</sup>  
 נָבֵהָ 1308<sup>b</sup>  
 נָבֵהָם 2109<sup>b</sup>; 2132<sup>a</sup>  
 נָבֵהָר 2109<sup>b</sup>

נָבֵהָ 2488<sup>b</sup>  
 נָבֵהָר 2155<sup>b</sup>  
 נָבֵל 1308<sup>b</sup>; 1377<sup>b</sup>  
 נָבֵל } 441<sup>a</sup>; 523<sup>b</sup>; 524<sup>a, b</sup>;  
 603<sup>a</sup>; 1120<sup>a</sup>;  
 נָבֵל } 1369<sup>b</sup>; 1394<sup>a</sup>;  
 1606<sup>b</sup>; 1798<sup>a</sup>;  
 נָבֵהָ } 1808<sup>b</sup>; 1813<sup>b</sup>;  
 1966<sup>b</sup>; 2422<sup>b</sup>;  
 נָבֵהָ } 2595<sup>a</sup>; 2792<sup>b</sup>;  
 2836<sup>b</sup>; 2866<sup>b</sup>;  
 3045<sup>a</sup>; 3151<sup>a</sup>  
 נָבֵהָ 1377<sup>b</sup>; 1468<sup>b</sup>  
 נָבֵלֵרָאָל 2109<sup>a</sup>  
 נָבֵלֵמֵר 2131<sup>a</sup>  
 נָבֵס 2153<sup>a</sup>; 2558<sup>a, b</sup>  
 נָבֵס 2109<sup>a</sup>  
 נָבֵמֵרָה 2131<sup>a</sup>  
 נָבֵמֵרֵי 2109<sup>a</sup>  
 נָבֵחַ 1343<sup>a</sup>  
 נָבֵרֵי } 2109<sup>a</sup>  
 נָבֵרֵי }  
 נָבֵשׁ 862<sup>b</sup>; 942<sup>a</sup>; 1068<sup>b</sup>;  
 2109<sup>b</sup>; 2737<sup>a, b</sup>  
 נָבֵשׁ 9<sup>b</sup>; 127<sup>a</sup>; 427<sup>a</sup>; 428<sup>b</sup>;  
 862<sup>b</sup>; 873<sup>a</sup>; 1492<sup>a</sup>;  
 2132<sup>a</sup>; 2703<sup>b</sup>;  
 2737<sup>a</sup>; 2738<sup>a</sup>  
 נָבֵשׁוֹן 2109<sup>b</sup>  
 נָבֵשׁת 416<sup>b</sup>; 514<sup>a</sup>; 589<sup>a</sup>;  
 708<sup>a</sup>; 1110<sup>b</sup>;  
 1111<sup>a</sup>; 2132<sup>a</sup>;  
 2737<sup>a</sup>; 3027<sup>b</sup>  
 נָבֵשׁתָא 2132<sup>a</sup>  
 נָבֵשׁתָן 1386<sup>a</sup>; 2132<sup>a</sup>; 2737<sup>a</sup>  
 נָבֵת 2743<sup>b</sup>  
 נָבֵת 2109<sup>b</sup>; 2515<sup>b</sup>  
 נָבֵהָ 68<sup>b</sup>; 511<sup>b</sup>; 798<sup>b</sup>;  
 816<sup>b</sup>; 2459<sup>a</sup>  
 נָבֵיפָה 589<sup>a</sup>; 674<sup>a</sup>; 2298<sup>a</sup>  
 נָבֵעֵרֵם 2139<sup>a</sup>  
 נָבֵס 674<sup>a</sup>  
 נָבֵס 2847<sup>b</sup>  
 נָבֵסָה 2140<sup>a</sup>  
 נָבֵר 1307<sup>b</sup>  
 נָבֵרָה 2147<sup>b</sup>  
 נָבֵסָן 541<sup>b</sup>; 2153<sup>a</sup>  
 נָבֵר } 1094<sup>a</sup>  
 נָבֵר }  
 נָבֵר }  
 נָבֵר }  
 נָבֵר } 517<sup>b</sup>; 552<sup>b</sup>; 1825<sup>a</sup>;  
 2134<sup>a</sup>  
 נָבֵר }  
 נָבֵרָה }

נכאח 2840<sup>a</sup>  
 נכה 288<sup>a</sup>; 665<sup>b</sup>; 1141<sup>a</sup>  
 נכה 13<sup>b</sup>  
 נכה 706<sup>a</sup>; 1823<sup>b</sup>  
 נכו 2129<sup>b</sup>; 2360<sup>a</sup>  
 נכוך 588<sup>a</sup>; 2108<sup>a</sup>  
 נכל 2868<sup>a</sup>  
 נכס 1279<sup>b</sup>  
 נכס 2590<sup>b</sup>; 3076<sup>a</sup>  
 נכר 851<sup>a</sup>; 1105<sup>a</sup>  
 נכר 97<sup>a</sup>; 2467<sup>b</sup>; 2865<sup>a, b</sup>  
 נכרי 97<sup>a</sup>; 1128<sup>a</sup>; 1339<sup>b</sup>;  
 2205<sup>a</sup>; 2467<sup>b</sup>;  
 2865<sup>a, b</sup>  
 נלה 943<sup>a</sup>  
 נמראל 2133<sup>b</sup>  
 נמראלי 2133<sup>b</sup>  
 נמלה 139<sup>a</sup>  
 נמר 1866<sup>b</sup>  
 נמר 1866<sup>b</sup>  
 נמרוד see נמרוד  
 נמרה 1866<sup>b</sup>; 2147<sup>a</sup>  
 נמרוד } 2147<sup>b</sup>  
 נמרוד }  
 נמרים 1866<sup>b</sup>; 2147<sup>a</sup>  
 נמשיר 2147<sup>b</sup>  
 נס 1584<sup>a</sup>; 2415<sup>b</sup>; 2776<sup>a</sup>;  
 3070<sup>b</sup>  
 נסבה 585<sup>a</sup>  
 נסג 328<sup>a</sup>  
 נסה see נשא  
 נסרף 882<sup>a</sup>; 1441<sup>b</sup>; 2454<sup>b</sup>  
 נסף 2454<sup>b</sup>; 2743<sup>a</sup>  
 נסף } 2639<sup>a, b</sup>; 2645<sup>a</sup>  
 נסף }  
 נסע 1141<sup>a</sup>  
 נסרף 2153<sup>a</sup>  
 נעה 2126<sup>a</sup>  
 נעה 2153<sup>b</sup>  
 נעיאל 2132<sup>b</sup>  
 נעל 494<sup>b</sup>; 2779<sup>a</sup>  
 נעל 2779<sup>a, b</sup>  
 נעם 2106<sup>a</sup>  
 נעם 421<sup>a</sup>  
 נעמה 2106<sup>a</sup>  
 נעמי 2118<sup>a</sup>  
 נעמן 2106<sup>a, b</sup>  
 נעמתי 2106<sup>b</sup>

נעצורין 1366<sup>a</sup>; 2974<sup>b</sup>  
 נער 348<sup>b</sup>; 512<sup>b</sup>; 606<sup>b</sup>;  
 1182<sup>a</sup>; 1212<sup>a</sup>;  
 1317<sup>a</sup>; 1821<sup>a</sup>;  
 1967<sup>b</sup>; 2316<sup>a</sup>;  
 2816<sup>b</sup>; 3127<sup>b</sup>  
 נערה 1967<sup>b</sup>; 2106<sup>b</sup>; 2107<sup>a</sup>;  
 2316<sup>a</sup>; 2960<sup>b</sup>;  
 3051<sup>b</sup>  
 נערי 2107<sup>a</sup>  
 נעריה 2126<sup>b</sup>  
 נערין 2107<sup>a</sup>  
 נערת 1118<sup>a</sup>; 3000<sup>b</sup>  
 נערתה see נערה  
 נם 2031<sup>a</sup>; 2155<sup>a</sup>  
 נפג 2133<sup>b</sup>  
 נפושאים 2134<sup>a</sup>  
 נפח 2495<sup>a</sup>  
 נפח 2155<sup>a</sup>  
 נפיל } 143<sup>b</sup>; 1224<sup>b</sup>; 2133<sup>b</sup>  
 נפל }  
 נפאים 2133<sup>b</sup>  
 נפיש 2118<sup>a</sup>  
 נפף 2856<sup>b</sup>; 2857<sup>a</sup>; 2860<sup>a</sup>;  
 2861<sup>a</sup>  
 נפל 576<sup>b</sup>; 1092<sup>a</sup>; 1148<sup>a</sup>;  
 3005<sup>a</sup>  
 נפל see נפיל  
 נפץ 507<sup>b</sup>  
 נפש 2545<sup>b</sup>  
 נפש 50<sup>a</sup>; 145<sup>b</sup>; 208<sup>b</sup>;  
 418<sup>b</sup>; 491<sup>b</sup>; 739<sup>a</sup>;  
 801<sup>a</sup>; 1224<sup>a</sup>;  
 1236<sup>b</sup>; 1351<sup>a</sup>;  
 1881<sup>a</sup>; 1888<sup>a, b</sup>;  
 1889<sup>a</sup>; 1906<sup>b</sup>;  
 1941<sup>b</sup>; 1942<sup>a</sup>;  
 2056<sup>a</sup>; 2263<sup>b</sup>;  
 2337<sup>a, b</sup>; 2408<sup>b</sup>;  
 2495<sup>a</sup>; 2496<sup>b</sup>;  
 2562<sup>b</sup>; 2563<sup>a</sup>;  
 2837<sup>a, b</sup>; 2838<sup>a</sup>;  
 3028<sup>a</sup>; 3085<sup>a</sup>  
 נפת 724<sup>a</sup>  
 נפח 1123<sup>b</sup>  
 נפתוח 2133<sup>b</sup>  
 נפתחים 2119<sup>b</sup>  
 נפתלי 2118<sup>b</sup>; 2119<sup>b</sup>  
 נץ 1120<sup>b</sup>; 1345<sup>a</sup>  
 נצב 1392<sup>b</sup>; 1443<sup>b</sup>; 2743<sup>b</sup>  
 נצב see נציב  
 נצב 830<sup>b</sup>  
 נצה 2625<sup>b</sup>  
 נצה see נוצה

נצה 1120<sup>b</sup>; 3050<sup>a</sup>  
 נצורה see נצר  
 נצה 170<sup>b</sup>; 1141<sup>a</sup>; 2205<sup>b</sup>;  
 2323<sup>a</sup>  
 נצה } 174<sup>b</sup>; 943<sup>a</sup>; 2323<sup>a</sup>  
 נצה }  
 נציב } 2141<sup>a</sup>; 2180<sup>b</sup>; 2398<sup>b</sup>  
 נצב }  
 נציה 2141<sup>a</sup>  
 נצל 820<sup>b</sup>; 2538<sup>b</sup>  
 נצן 1120<sup>b</sup>  
 נצר 1175<sup>a</sup>; 2123<sup>a</sup>; 2868<sup>a</sup>;  
 3046<sup>b</sup>; 3074<sup>a</sup>  
 נצר 513<sup>b</sup>; 1633<sup>b</sup>; 2221<sup>a</sup>  
 נקב 210<sup>a</sup>; 485<sup>b</sup>; 1106<sup>b</sup>;  
 2112<sup>a</sup>  
 נקב 2133<sup>a</sup>  
 נקבה 1106<sup>b</sup>; 1971<sup>b</sup>  
 נקד 1375<sup>b</sup>; 2758<sup>a</sup>  
 נקד 734<sup>a</sup>  
 נקדה 2867<sup>b</sup>  
 נקה 668<sup>a</sup>; 2515<sup>b</sup>  
 נקודא 2133<sup>a</sup>  
 נקי } 667<sup>a, b</sup>; 1471<sup>a</sup>; 2515<sup>b</sup>  
 נקיא }  
 נקיון } 1470<sup>b</sup>; 1471<sup>a</sup>  
 נקין }  
 נקם 340<sup>a, b</sup>; 2587<sup>a</sup>  
 נקם 2512<sup>b</sup>  
 נר see ניר  
 נרגל 2134<sup>b</sup>  
 נרגל שראצור 2134<sup>b</sup>  
 נרד 2840<sup>b</sup>  
 נרה see ניר  
 נריה } 2134<sup>b</sup>  
 נריה }  
 נריה } 27<sup>b</sup>; 254<sup>a</sup>; 288<sup>b</sup>;  
 418<sup>a</sup>; 528<sup>b</sup>; 580<sup>b</sup>;  
 728<sup>b</sup>; 1049<sup>b</sup>;  
 1107<sup>b</sup>; 1132<sup>b</sup>;  
 1133<sup>a</sup>; 1149<sup>b</sup>;  
 1150<sup>b</sup>; 1221<sup>a</sup>;  
 1248<sup>a</sup>; 1418<sup>b</sup>;  
 1890<sup>b</sup>; 2399<sup>a</sup>;  
 2454<sup>a</sup>; 2469<sup>b</sup>;  
 2561<sup>b</sup>; 2903<sup>b</sup>;  
 2942<sup>b</sup>; 3046<sup>a</sup>  
 נשא 1484<sup>a</sup>  
 נשא 1049<sup>b</sup>  
 נשיא see נשיא  
 נשיאה see נשיאה



נְשָׂה 741<sup>a</sup>; 816<sup>a</sup>; 1049<sup>b</sup>;  
 1865<sup>b</sup>; 3041<sup>b</sup>  
 נְשִׂאָה } 580<sup>b</sup>  
 נְשִׂאָה }  
 נְשִׂי 814<sup>a</sup>  
 נְשִׂיא { 569<sup>a</sup>; 755<sup>a</sup>; 1289<sup>b</sup>;  
 1441<sup>b</sup>; 2454<sup>a</sup>;  
 נְשִׂא { 2626<sup>a</sup>; 2689<sup>b</sup>;  
 3046<sup>a</sup>  
 נְשִׂיָה 2080<sup>a</sup>  
 נְשִׂים see אִשָּׁה  
 נְשִׂיקָה 1813<sup>b</sup>  
 נְשִׂיף 1865<sup>b</sup>; 3041<sup>b</sup>  
 נְשִׂיף 3041<sup>a</sup>  
 נְשִׂקָה 591<sup>b</sup>  
 נְשִׂם 592<sup>a</sup>; 1826<sup>a</sup>  
 נְשִׂמָה 145<sup>b</sup>; 486<sup>b</sup>; 518<sup>a</sup>;  
 592<sup>a</sup>; 973<sup>a</sup>; 1474<sup>a</sup>;  
 2495<sup>a</sup>  
 נְשִׂה 490<sup>b</sup>  
 נְשִׂה 797<sup>b</sup>; 798<sup>b</sup>; 2143<sup>b</sup>  
 נְשִׂק 1813<sup>b</sup>; 1814<sup>a</sup>  
 נְשִׂק } 251<sup>a</sup>; 254<sup>b</sup>; 1340<sup>b</sup>;  
 נְשִׂק } 1488<sup>b</sup>  
 נְשִׂר 885<sup>a</sup>  
 נְתִבָה see נְתִיב  
 נְתִיךְ see נְתִיךְ  
 נְתִה 5<sup>a</sup>; 769<sup>b</sup>  
 נְתִיב } 535<sup>b</sup>; 2263<sup>a</sup>; 3007<sup>b</sup>;  
 נְתִיבָה } 3075<sup>b</sup>  
 נְתִיבָה }  
 נְתִיךְ } 2825<sup>b</sup>  
 נְתִיךְ }  
 נְתִיךְ 2139<sup>b</sup>; 2825<sup>b</sup>  
 נְתִיף 2052<sup>a</sup>  
 נְתִן 173<sup>b</sup>; 210<sup>a</sup>; 728<sup>b</sup>;  
 820<sup>b</sup>; 1144<sup>b</sup>;  
 1228<sup>b</sup>; 1232<sup>b</sup>;  
 1395<sup>a</sup>; 1859<sup>a</sup>;  
 1865<sup>b</sup>; 1968<sup>a</sup>;  
 2178<sup>a</sup>; 2825<sup>b</sup>  
 נְתִן 2120<sup>a</sup>; 2450<sup>a</sup>  
 נְתִנָּא 2121<sup>a</sup>; 2139<sup>a</sup>  
 נְתִנָּה } 2139<sup>a</sup>  
 נְתִנָּה }  
 נְתִן-מִלְכָּה 2121<sup>b</sup>  
 נְתִעַ 3081<sup>b</sup>  
 נְתִיץ 517<sup>b</sup>  
 נְתִק 517<sup>b</sup>  
 נְתִק 2701<sup>b</sup>; 3081<sup>b</sup>  
 נְתִר 316<sup>b</sup>  
 נְתִר 2153<sup>a</sup>

ט  
 טָאָה 931<sup>b</sup>; 1123<sup>b</sup>; 2708<sup>a</sup>;  
 3080<sup>a</sup>  
 טָאֹךְ 503<sup>b</sup>  
 טָאָהָה 2016<sup>a</sup>  
 טָבָא 2629<sup>a</sup>; 3088<sup>a</sup>  
 טָבָא 2710<sup>b</sup>  
 טָבָא 3086<sup>b</sup>  
 טָבָאִי 2629<sup>a</sup>  
 טָבָב 656<sup>b</sup>; 694<sup>b</sup>; 706<sup>a</sup>;  
 1107<sup>b</sup>  
 טָבִיב } 656<sup>b</sup>  
 טָבִיבָה }  
 טָבִיף 1121<sup>a</sup>  
 טָבִיף 2972<sup>a</sup>  
 טָבִיף 1132<sup>a</sup>; 1437<sup>a</sup>; 2972<sup>a</sup>  
 טָבִיקָא } 2095<sup>a</sup>; 2097<sup>a</sup>  
 טָבִיקָא }  
 טָבִיכִי 2783<sup>a</sup>  
 טָבִל 528<sup>b</sup>  
 טָבִלָה 1060<sup>a</sup>  
 טָבִלַת 2783<sup>a</sup>  
 טָבִירִים 2783<sup>a</sup>  
 טָבִיתָא } 2636<sup>a</sup>  
 טָבִיתָה }  
 טָבִיתָא 2636<sup>a</sup>  
 טָגִד 3110<sup>a</sup>  
 טָגִד 3110<sup>a</sup>  
 טָגִד 584<sup>a</sup>; 709<sup>a</sup>  
 טָגִלָה 2294<sup>b</sup>  
 טָגִן 263<sup>a</sup>  
 טָגִן 830<sup>b</sup>; 1289<sup>b</sup>; 1965<sup>a</sup>;  
 2626<sup>a</sup>  
 טָגִר 584<sup>a</sup>; 669<sup>b</sup>; 2558<sup>a</sup>;  
 2864<sup>a</sup>  
 טָרִיךְ 876<sup>a</sup>; 1111<sup>a</sup>; 1894<sup>a</sup>  
 טָדָם 2821<sup>b</sup>  
 טָדָר 1083<sup>a</sup>; 2200<sup>b</sup>; 2905<sup>a</sup>  
 טָהָר 2178<sup>a</sup>  
 טָהָר 2456<sup>a</sup>  
 טָוָא 2820<sup>a</sup>  
 טָוִג 376<sup>b</sup>  
 טָוִג see טָוִג  
 טָוִר 1441<sup>a</sup>  
 טָוִר 132<sup>b</sup>; 1681<sup>b</sup>; 2105<sup>a</sup>  
 טָוִרִי 2821<sup>a</sup>  
 טָוִת 2868<sup>a</sup>  
 טָוִי 2837<sup>a</sup>  
 טָוִי 138<sup>a</sup>

סוּמְפִּוּנָּה }  
 סוּמְפִּוּנָּה } 2095<sup>a</sup>; 2097<sup>a</sup>  
 סוּמְפִּוּנָּה }  
 סוּנָה }  
 סוּנָה } 914<sup>a</sup>; 2744<sup>a</sup>  
 סוּן }  
 סוּס } 1422<sup>b</sup>; 2874<sup>a, b</sup>  
 סוּס }  
 סוּסָה 1423<sup>b</sup>; 1985<sup>a</sup>  
 סוּסִי 2874<sup>a</sup>  
 סוּסָה 242<sup>a</sup>; 704<sup>b</sup>; 1052<sup>b</sup>;  
 1117<sup>b</sup>; 2538<sup>b</sup>;  
 2871<sup>a</sup>; 3078<sup>b</sup>  
 סוּסָה 696<sup>b</sup>; 943<sup>a</sup>  
 סוּסָה 2871<sup>b</sup>; 3083<sup>a</sup>  
 סוּר } 816<sup>b</sup>; 819<sup>a</sup>; 993<sup>a</sup>;  
 סוּר } 1248<sup>a</sup>; 2838<sup>a</sup>  
 סוּרָה 671<sup>a</sup>; 2524<sup>b</sup>  
 סוּרִי 2180<sup>b</sup>  
 סוּרִי 687<sup>b</sup>; 1995<sup>b</sup>  
 סוּרִי 2035<sup>b</sup>  
 סוּרִי 3002<sup>b</sup>; 3004<sup>b</sup>  
 סוּרִיה 2035<sup>b</sup>  
 סוּרִית 1984<sup>b</sup>  
 סוּג } 880<sup>a</sup>  
 סוּג }  
 סוּגִן 541<sup>b</sup>; 2813<sup>b</sup>  
 סוּחֹן } 2790<sup>a</sup>  
 סוּחֹן }  
 סוּן 2802<sup>a</sup>  
 סוּנִי 2805<sup>b</sup>  
 סוּנִי 2802<sup>b</sup>  
 סוּנִים 2805<sup>b</sup>  
 סוּסָרָא 2812<sup>b</sup>  
 סוּסָרָא } 2783<sup>a</sup>  
 סוּסָרָא }  
 סוּמְפִּוּנָּה see סוּמְפִּוּנָּה  
 סוּר 541<sup>a</sup>; 1116<sup>a</sup>; 1119<sup>b</sup>;  
 1419<sup>a</sup>; 2237<sup>a</sup>;  
 2423<sup>a</sup>; 2974<sup>b</sup>;  
 3073<sup>b</sup>  
 סוּרָה }  
 סוּרָה } 829<sup>b</sup>; 2292<sup>b</sup>  
 סוּרָה } 503<sup>b</sup>; 829<sup>b</sup>; 2292<sup>b</sup>;  
 2948<sup>a</sup>  
 סוּרָת } 2869<sup>a</sup>  
 סוּרָת }  
 סוּרָת בְּנוּת 2869<sup>a</sup>  
 סוּרִי 2870<sup>a</sup>

קָבַד	} 2743 <sup>a</sup>	סָפָה	see קָרִית־סָפָה	סָרַד	2732 <sup>b</sup>
שָׁבַד		סָנְוֹאָה	} 1342 <sup>a, b</sup> ; 2721 <sup>a</sup>	סָרִיס	} 591 <sup>b</sup> ; 1037 <sup>a</sup> ; 2180 <sup>b</sup>
סָבְכָה	2711 <sup>a</sup>	סָנְאָה		סָרַס	
סָבַל	896 <sup>b</sup> ; 1125 <sup>a</sup>	סָנְחָרִיב	2720 <sup>a</sup>	סָרְזַן	1929 <sup>b</sup> ; 2377 <sup>a</sup> ; 2408 <sup>a</sup>
סָבַל	1124 <sup>a, b</sup> ; 1125 <sup>a</sup> ; 2837 <sup>a</sup>	סָסְסָה	2690 <sup>a</sup>	סָרְעָפָה	513 <sup>b</sup>
סָבְלוֹת	} 896 <sup>b</sup> ; 1125 <sup>a</sup>	סָס	2091 <sup>b</sup> ; 2092 <sup>a</sup> ; 3109 <sup>a</sup>	סָרְפַד	2974 <sup>b</sup>
שָׁבְלוֹת		סָס	see סָרַס	סָרַר	376 <sup>b</sup>
סָבַן	64 <sup>b</sup> ; 603 <sup>a</sup> ; 2450 <sup>a</sup> ; 2753 <sup>b</sup> ; 2754 <sup>a</sup> ; 2853 <sup>b</sup> ; 3008 <sup>a</sup> ; 3129 <sup>a</sup>	סָסְמִי	2813 <sup>a</sup>	סָרְוִי	} 2710 <sup>b</sup> ; 3089 <sup>a</sup>
סָבַת	see סָבוֹת	סָעַד	2545 <sup>b</sup>	סָרְוִי	
סָל	412 <sup>b</sup> ; 413 <sup>a</sup>	סָעִיָה	513 <sup>b</sup>	סָרְזִיר	2743 <sup>b</sup>
סָלָא	2791 <sup>a</sup>	סָעִיָה	2198 <sup>a</sup>	סָתַס	} 430 <sup>a</sup>
סָלַד	1338 <sup>b</sup>	שָׁעִיָה	} 2198 <sup>a</sup>	שָׁתַס	
סָלַד	2714 <sup>a</sup>	סָעָפָה		513 <sup>b</sup>	סָתַר
סָלָה	2096 <sup>b</sup> ; 2488 <sup>b</sup> ; 2963 <sup>a</sup>	סָעַר	} 2929 <sup>b</sup> ; 3083 <sup>a</sup>	סָתַר	} 376 <sup>b</sup>
סָלוּ	} 2663 <sup>a</sup> ; 2664 <sup>b</sup>	סָעָרָה		} 2929 <sup>b</sup> ; 3083 <sup>a</sup>	
סָלוּא		סָה	1175 <sup>b</sup> ; 1435 <sup>b</sup> ; 1436 <sup>b</sup> ; 2690 <sup>b</sup>		סָתַרִי
סָלוּא	} 2663 <sup>a</sup> ; 2664 <sup>b</sup>	סָפָה	704 <sup>b</sup> ; 1350 <sup>b</sup>	ע	
סָלְוִי		סָפָה	} 2701 <sup>a</sup>	עָב	670 <sup>a</sup> ; 1132 <sup>a</sup>
סָלוּן	} 2974 <sup>b</sup>	שָׁפָה		1867 <sup>a</sup> ; 2701 <sup>a</sup>	עָבַד
סָלוּן		סָפַחַת	2774 <sup>a</sup> ; 2775 <sup>a</sup>	עָבַד	1968 <sup>a</sup>
סָלַח	1132 <sup>b</sup> ; 1133 <sup>a</sup>	סָפִינָה	2774 <sup>a</sup> ; 2775 <sup>a</sup>	עָבַד	495 <sup>a</sup> ; 890 <sup>b</sup> ; 1182 <sup>a</sup> ; 1983 <sup>b</sup> ; 2738 <sup>b</sup> ; 2815 <sup>a</sup> ; 2825 <sup>b</sup>
סָלְוִי	see סָלְוִי	סָפִיר	709 <sup>a</sup> ; 2856 <sup>b</sup> ; 2857 <sup>a</sup> ; 2861 <sup>b</sup>	עָבְדָא	4 <sup>a</sup>
סָלְכָה	2662 <sup>b</sup>	סָפַל	511 <sup>b</sup> ; 854 <sup>b</sup>	עָבַד אֲדוּס	2175 <sup>a</sup>
סָלַל	1392 <sup>b</sup>	סָפַן	587 <sup>a</sup>	עָבְדָאֵל	4 <sup>a</sup>
סָלְלָה	} 383 <sup>a</sup> ; 1392 <sup>b</sup> ; 2787 <sup>a</sup>	סָפַן	587 <sup>a</sup>	עָבְדָה	} 176 <sup>a</sup> ; 494 <sup>b</sup> ; 495 <sup>a</sup> ; 2742 <sup>b</sup>
סוּלְלָה		סָפַק	} 665 <sup>b</sup>	עָבְדָה	
סָלַע	737 <sup>a</sup> ; 1119 <sup>b</sup> ; 2032 <sup>b</sup> ; 2216 <sup>a</sup> ; 2593 <sup>b</sup> ; 2596 <sup>a</sup> ; 2713 <sup>b</sup> ; 2856 <sup>a</sup>	שָׁפַק		} 665 <sup>b</sup>	עָבְדוֹן
סָלַע	} 2714 <sup>a</sup>	סָפַר	256 <sup>b</sup> ; 336 <sup>a</sup> ; 723 <sup>b</sup> ; 813 <sup>b</sup> ; 902 <sup>b</sup> ; 903 <sup>a, b</sup> ; 1815 <sup>b</sup> ; 1886 <sup>a</sup> ; 2000 <sup>a</sup> ; 2689 <sup>b</sup> ; 2704 <sup>b</sup> ; 2754 <sup>a</sup> ; 3123 <sup>a</sup>		עָבְדוֹת
הַפְּתִילָקוֹת		סָלַע	} 182 <sup>b</sup> ; 495 <sup>b</sup> ; 496 <sup>a</sup> ; 503 <sup>a, b</sup> ; 729 <sup>b</sup> ; 1041 <sup>b</sup> ; 1570 <sup>a</sup> ; 1812 <sup>b</sup> ; 2487 <sup>a</sup> ; 2597 <sup>a</sup> ; 3123 <sup>a</sup>	עָבְדִי	4 <sup>a</sup>
סָלַעַם	1473 <sup>a</sup> ; 1907 <sup>b</sup> ; 1908 <sup>a</sup>	סָפַר		עָבְדִיאֵל	4 <sup>a</sup>
סָלַת	1111 <sup>a</sup> ; 1122 <sup>a</sup>	סָפַרְהַ	עָבְדִיָה	} 2173 <sup>a</sup>	
סָס	2840 <sup>a</sup>	סָפַרְהַ	עָבְדִיָה		
סָמְצַר נְבוּ	2674 <sup>b</sup>	סָפַרְהַ	עָבַד מְלִיךָ	890 <sup>b</sup>	
סָמְדַר	2947 <sup>a</sup> ; 3050 <sup>a</sup>	סָפַרְדַּ	עָבַד נְגוּ	} 4 <sup>b</sup>	
סָמְזָה	1337 <sup>b</sup>	סָפַרְהַ	עָבַד נְגוּאָה		
סָמְכָרְוִי	2717 <sup>a</sup>	see סָפַר	עָבוֹט	} 1049 <sup>b</sup> ; 2408 <sup>b</sup>	
סָמַל	} 1109 <sup>b</sup> ; 1455 <sup>b</sup>	סָפַרְוִי	עָבַט		
סָמַל		סָפַרְוִי	2722 <sup>a</sup>	עָבוֹר	} 585 <sup>a</sup> ; 1484 <sup>a</sup>
סָנְאָה	2719 <sup>b</sup>	סָפַרְוִי	2255 <sup>a</sup> ; 2721 <sup>b</sup>	עָבַר	
סָנְאָה	see סָנְאָה	סָפַרְתַּ	2836 <sup>a</sup>	עָבַט	} 667 <sup>a</sup> ; 1865 <sup>b</sup>
סָנְבַלַּט	2681 <sup>a</sup>	סָר	1354 <sup>b</sup>	עָבַטִיט	
סָנָה	532 <sup>a, b</sup>	סָרַב	2974 <sup>b</sup>	עָבִי	} 667 <sup>a</sup> ; 2000 <sup>a</sup>
סָנָה	2720 <sup>a</sup>	סָרַבַּל	518 <sup>b</sup>	עָבִי	
		סָרְגוֹן	2693 <sup>a</sup>		

עֲבִירָה	2742 <sup>b</sup>	עֲדָלִי	56 <sup>b</sup>	עֵה	1086 <sup>b</sup> ; 1121 <sup>a</sup> ; 1142 <sup>b</sup>
עֲבָר	97 <sup>a</sup> ; 459 <sup>a</sup> ; 728 <sup>b</sup> ; 1127 <sup>a</sup> ; 1183 <sup>b</sup> ; 1248 <sup>a</sup> ; 1355 <sup>a</sup> ; 2081 <sup>a</sup> ; 2205 <sup>a</sup> ; 2255 <sup>b</sup> ; 3076 <sup>a</sup>	עֲדָלָם	62 <sup>b</sup>	עוֹה	425 <sup>a</sup> ; 744 <sup>a</sup> ; 1142 <sup>b</sup>
עֲבָר	459 <sup>a</sup>	עֲדָן	152 <sup>a</sup> ; 820 <sup>a</sup> ; 897 <sup>b</sup>	עוֹפְרָת	} 1861 <sup>a</sup>
עֲבָר	226 <sup>a</sup> ; 459 <sup>a</sup> ; 890 <sup>b</sup> ; 1354 <sup>b</sup> ; 1758 <sup>a</sup>	עֲדָן	306 <sup>a</sup>	עֲפָרָת	
עֲבָרָה	1127 <sup>a,b</sup>	עֲדָנָא	56 <sup>b</sup>	עוֹפִי	955 <sup>b</sup>
עֲבָרִי	1355 <sup>a</sup> ; 1446 <sup>a</sup> ; 1513 <sup>b</sup> ; 1514 <sup>a</sup>	עֲדָנָה	57 <sup>a</sup>	עוֹץ	1343 <sup>a</sup> ; 3042 <sup>a,b</sup>
עֲבָרִים	3 <sup>b</sup>	עֲדָעָה	48 <sup>a</sup> ; 259 <sup>b</sup>	עוֹר	340 <sup>b</sup> ; 2527 <sup>a</sup>
עֲבָרָן	894 <sup>b</sup>	עֲדָה	2205 <sup>a</sup>	עוֹר	593 <sup>a</sup> ; 2111 <sup>a</sup> ; 2834 <sup>b</sup>
עֲבָרָנָה	23 <sup>a</sup>	עֲדָר	259 <sup>b</sup> ; 1086 <sup>a</sup> ; 2200 <sup>a</sup>	עוֹר	377 <sup>a</sup> ; 1862 <sup>a</sup> ; 2422 <sup>a</sup> ; 2709 <sup>b</sup> ; 2813 <sup>b</sup> ; 2814 <sup>a</sup>
עֲבָשׁ	2624 <sup>a</sup>	עֲדָר	584 <sup>a,b</sup> ; 899 <sup>a</sup>	עוֹר	487 <sup>b</sup>
עֲבָת	} 2972 <sup>a</sup>	עֲדָרָא	899 <sup>a</sup>	עוֹרָב	see עֲרָב
עֲבוֹת			עֲדָרָאֵל	62 <sup>b</sup>	עוֹרָת
עֲבָת	} 382 <sup>a</sup> ; 709 <sup>b</sup> ; 2623 <sup>b</sup>	עֲדָשׁ	1122 <sup>a</sup> ; 1866 <sup>a</sup>	עוֹרָתִי	3042 <sup>a</sup>
עֲבוֹת			עֲדָא	see עֲדָה	עֵז
עֲבָתָה		עוֹבָר	2175 <sup>a</sup>	עֵז	1123 <sup>a</sup> ; 1248 <sup>b</sup> ; 1249 <sup>b</sup> ; 1797 <sup>b</sup>
עֲבָב	1934 <sup>a</sup>	עוֹבָל	889 <sup>b</sup>	עֵזָא	} 3043 <sup>a</sup>
עֲבָב	1934 <sup>a</sup>	עוֹנ	2180 <sup>b</sup>	עֵזָה	
עֲבָבָה	1472 <sup>b</sup>	עוֹנָב	} 2095 <sup>a</sup> ; 2097 <sup>a</sup>	עֵזָזֵל	342 <sup>b</sup> ; 2144 <sup>a</sup>
עֲבָר	737 <sup>a</sup> ; 2874 <sup>a,b</sup>	עֲנָב			עֵזָבוֹן
עֲבָרָל	2594 <sup>b</sup>	עוֹרָד	} 2178 <sup>b</sup>	עֵזָבוֹק	344 <sup>a</sup>
עֲבָל	542 <sup>a,b</sup>	עוֹרָד			עֵזָגָר
עֲבָלָה	734 <sup>a</sup> ; 905 <sup>b</sup> ; 1367 <sup>b</sup> ; 1905 <sup>b</sup> ; 2999 <sup>b</sup>	עוֹרָה	87 <sup>b</sup> ; 760 <sup>b</sup> ; 2348 <sup>a</sup>	עֵזָה	345 <sup>b</sup> ; 1178 <sup>a</sup>
עֲבָלָה	581 <sup>a</sup>	עוֹרָה	340 <sup>b</sup>	עֵזָהָה	345 <sup>b</sup>
עֲבָלוֹן	905 <sup>b</sup> ; 906 <sup>a</sup>	עוֹרָה	} 1374 <sup>b</sup> ; 1469 <sup>a</sup> ; 1544 <sup>b</sup>	עֵזָר	} 345 <sup>b</sup>
עֲד	120 <sup>a</sup> ; 1041 <sup>a</sup> ; 1338 <sup>a</sup> ; 1395 <sup>b</sup> ; 2323 <sup>b</sup> ; 2411 <sup>a</sup>	עוֹרָא			
עֲד	748 <sup>b</sup> ; 897 <sup>a</sup> ; 1110 <sup>b</sup> ; 1852 <sup>a,b</sup> ; 3099 <sup>a</sup>	עוֹרָן	see עוֹן	עֵזָר	342 <sup>b</sup> ; 1337 <sup>b</sup> ; 1338 <sup>b</sup>
עֲדָר	see עוֹרָד	עוֹרָם	340 <sup>b</sup>	עֵזָר	342 <sup>b</sup>
עֲדָה	48 <sup>b</sup>	עוֹרָת	} 340 <sup>b</sup> ; 2132 <sup>b</sup>	עֵזָרָה	344 <sup>a</sup>
עֲדָה	132 <sup>b</sup> ; 653 <sup>b</sup> ; 700 <sup>b</sup> ; 701 <sup>a</sup> ; 3099 <sup>a</sup>	עוֹרָת			עֵזָרִי
עֲדָו	} 1447 <sup>b</sup>	עוֹל	103 <sup>b</sup> ; 734 <sup>a</sup> ; 1049 <sup>a</sup>	עֵזָרָא	3043 <sup>b</sup>
עֲדָוָא			עוֹל	1819 <sup>b</sup>	עֵזָרָאֵל
עֲדָוָא		עוֹל	see עֵל	עֵזָרָאֵלִי	3044 <sup>b</sup>
עֲדָרָת	244 <sup>b</sup> ; 905 <sup>a</sup> ; 1063 <sup>a,b</sup> ; 1578 <sup>b</sup>	עוֹלָ	} 1469 <sup>a</sup> ; 3083 <sup>b</sup>	עֵזָרָה	} 3043 <sup>a,b</sup>
עֲדָרִי	2201 <sup>b</sup>	עוֹלָה			
עֲדָרָה	} 48 <sup>b</sup>	עוֹלָה	see עֵלָה	עֵזָרָתָא	344 <sup>b</sup>
עֲדָרָהָה			עוֹלָל	} 348 <sup>b</sup>	עֵזָרָתָנָה
עֲדָרָן	55 <sup>b</sup>	עוֹלָל			עֵזָרָתָן
עֲדָרָנָא	55 <sup>b</sup>	עוֹלָם	} 130 <sup>b</sup> ; 705 <sup>a</sup> ; 1010 <sup>b</sup> ; 1011 <sup>a</sup> ; 1041 <sup>a</sup> ; 2323 <sup>a</sup> ; 2504 <sup>a</sup> ; 2925 <sup>a</sup> ; 3106 <sup>a</sup> ; 3108 <sup>b</sup>	עֵזָרָתָה	2202 <sup>a</sup>
עֲדָרָנוֹ	56 <sup>a</sup>	עוֹלָם			עֵזָק
עֲדָרָתָם	56 <sup>a</sup>	עוֹנ	1070 <sup>a</sup>	עֵזָקָא	2708 <sup>a</sup>
		עוֹן	} 1101 <sup>b</sup> ; 1468 <sup>b</sup> ; 1469 <sup>a</sup> ; 2504 <sup>b</sup> ; 2798 <sup>b</sup>	עֵזָקָה	344 <sup>a</sup>
		עוֹן			עֵזָר
		עוֹן		עֵזָר	1374 <sup>a</sup>
		עוֹנָה	883 <sup>b</sup>	עֵזָר	1040 <sup>b</sup> ; 1081 <sup>b</sup> ; 3100 <sup>a</sup>

עֲזָרָא 1082<sup>a</sup>  
 עֲזָרְאֵל 342<sup>a</sup>  
 עֲזָרָה } 1374<sup>a</sup>  
 עֲזָרְתָה }  
 עֲזָרָה 1082<sup>a</sup>  
 עֲזָרָה 1864<sup>b</sup>; 2743<sup>b</sup>  
 עֲזָרִי 1085<sup>b</sup>  
 עֲזָרִיאֵל 345<sup>a</sup>  
 עֲזָרִיָּה } 342<sup>a</sup>; 3043<sup>b</sup>  
 עֲזָרִיָּהוּ }  
 עֲזָרִיקָם 345<sup>a</sup>  
 עֲזָתִי 1179<sup>a</sup>  
 עֲט 2297<sup>b</sup>  
 עֲטָה 259<sup>b</sup>  
 עֲטִין 2052<sup>a</sup>  
 עֲטִישָׁה 2130<sup>a</sup>; 2819<sup>b</sup>  
 עֲטִלָּה 414<sup>a</sup>  
 עֲטָם 1086<sup>b</sup>  
 עֲטָר 762<sup>a</sup>  
 עֲטָרָה 317<sup>a</sup>; 762<sup>a</sup>; 763<sup>a</sup>;  
 1801<sup>a</sup>  
 עֲטָרוֹת 317<sup>a</sup>  
 עֲטָרוֹת אֲדָר 317<sup>a</sup>  
 עֲטָרוֹת בַּיִת } 328<sup>a</sup>  
 יוֹאָב }  
 עֲטָרוֹת שׁוֹפָן 328<sup>a</sup>; 2779<sup>b</sup>  
 עֵי }  
 עֵינָא } 87<sup>b</sup>; 88<sup>a</sup>; 1319<sup>b</sup>  
 עֵינָה }  
 עֵיבָל 889<sup>b</sup>  
 עֵינָה see עֵי  
 עֵיוֹן 1449<sup>a</sup>  
 עֵיט 1121<sup>a</sup>; 2525<sup>b</sup>  
 עֵיט 475<sup>a</sup>; 1142<sup>b</sup>; 1444<sup>a</sup>;  
 2533<sup>b</sup>  
 עֵיטָם 1010<sup>a</sup>  
 עֵינֵי הַעֲבָרִים 1545<sup>a</sup>  
 עֵינִים 1449<sup>a</sup>  
 עֵילִי 1449<sup>a</sup>  
 עֵילָם } 917<sup>a</sup>  
 עֵילָם }  
 עֵירִי 88<sup>b</sup>; 210<sup>a</sup>; 267<sup>a</sup>;  
 342<sup>a</sup>; 658<sup>a</sup>; 674<sup>b</sup>;  
 724<sup>a</sup>; 941<sup>b</sup>; 1042<sup>b</sup>;  
 1069<sup>b</sup>; 1085<sup>b</sup>;  
 1150<sup>b</sup>; 2196<sup>b</sup>;  
 2438<sup>a</sup>; 3081<sup>a</sup>  
 עֵין גָּדִי 945<sup>a</sup>  
 עֵין גַּנִּים 945<sup>a</sup>

עֵין-דָּאָר }  
 עֵין הַדֹּר } 943<sup>b</sup>  
 עֵין-הַדֹּר }  
 עֵין הַקּוֹרָא 952<sup>b</sup>  
 עֵין חֲדָה 952<sup>a</sup>  
 עֵין חֲצוֹר 952<sup>b</sup>  
 עֵין חֲרָד 1340<sup>b</sup>  
 עֵינִים } 941<sup>b</sup>  
 עֵינָם }  
 עֵינָן 942<sup>a</sup>; 1346<sup>b</sup>  
 עֵין עֲגִלִים 944<sup>b</sup>  
 עֵין רִגְל 953<sup>b</sup>  
 עֵין רַמּוֹן 953<sup>b</sup>  
 עֵין שָׁמֶשׁ 954<sup>b</sup>  
 עֵין תַּנִּים 1548<sup>b</sup>  
 עֵין תַּפְּסִיחַ 954<sup>b</sup>  
 עֵיִם 1086<sup>b</sup>  
 עֵיפָה 955<sup>b</sup>  
 } 87<sup>b</sup>; 132<sup>b</sup>; 171<sup>b</sup>;  
 211<sup>a</sup>; 288<sup>b</sup>; 662<sup>a</sup>;  
 עֵיר 665<sup>a,b</sup>; 1136<sup>b</sup>;  
 1337<sup>a</sup>; 1376<sup>b</sup>;  
 עֵיר } 1491<sup>a</sup>; 1492<sup>a</sup>;  
 1596<sup>b</sup>; 1810<sup>b</sup>;  
 עֵיר } 2191<sup>a</sup>; 2545<sup>b</sup>;  
 2552<sup>b</sup>; 3001<sup>a</sup>;  
 3074<sup>a</sup>; 3134<sup>b</sup>  
 עֵיר 287<sup>a</sup>; 678<sup>a,b</sup>  
 עֵירָא 1491<sup>a</sup>  
 עֵירָד 1491<sup>a</sup>; 1570<sup>a</sup>  
 עֵיר הַמְּלָח 2664<sup>b</sup>  
 עֵיר הַתְּמָרִים 666<sup>b</sup>  
 עֵירוֹ 1493<sup>a</sup>  
 עֵירִי 1492<sup>a</sup>  
 עֵירָם 1491<sup>a</sup>  
 עֵיר נָחֶשׁ 1492<sup>a</sup>  
 עֵיר שָׁמֶשׁ 1493<sup>a</sup>  
 עֵרֶשׁ } 311<sup>a</sup>; 313<sup>a,b</sup>; 314<sup>b</sup>  
 עֵרֶשׁ }  
 עֵרֶת see עֵי  
 עֵקְבוֹר 36<sup>a</sup>; 2092<sup>b</sup>  
 עֵקְבִישׁ 2737<sup>b</sup>; 2840<sup>b</sup>  
 עֵקְבָר 1106<sup>b</sup>; 1906<sup>a</sup>; 1907<sup>a</sup>;  
 2092<sup>b</sup>  
 עֵכּוֹ 28<sup>a</sup>  
 עֵכוֹר 37<sup>a</sup>  
 עֵכָן 35<sup>b</sup>  
 עֵקְסָה 37<sup>a</sup>  
 עֵקָר 35<sup>b</sup>; 579<sup>b</sup>; 2178<sup>a</sup>;  
 2854<sup>b</sup>  
 עֵקָר 35<sup>b</sup>; 579<sup>b</sup>

עֵקְרָן 2178<sup>a</sup>  
 עֵקְשׁוּיָב 55<sup>a</sup>; 2737<sup>b</sup>; 2738<sup>a</sup>  
 עֵל 585<sup>b</sup>; 678<sup>b</sup>; 728<sup>b</sup>;  
 1136<sup>b</sup>; 1559<sup>a</sup>;  
 2411<sup>b</sup>; 2779<sup>b</sup>;  
 2961<sup>b</sup>  
 עֵל } 2976<sup>a</sup>; 3126<sup>b</sup>  
 עֵל }  
 עֵלָא 3033<sup>a</sup>  
 עֵלָג 2848<sup>a</sup>  
 עֵלָה 522<sup>b</sup>; 605<sup>b</sup>; 797<sup>b</sup>;  
 1107<sup>b</sup>; 1221<sup>a</sup>;  
 1248<sup>a</sup>; 1267<sup>a</sup>;  
 1392<sup>b</sup>; 2639<sup>a</sup>;  
 3046<sup>a</sup>  
 עֵלָה 1861<sup>b</sup>  
 עֵלָה } 266<sup>b</sup>; 2639<sup>a,b</sup>; 2641<sup>a</sup>;  
 2642<sup>b</sup>; 2643<sup>a</sup>;  
 עֵלָה } 2644<sup>a</sup>  
 עֵלָה 112<sup>b</sup>  
 עֵלָה } 97<sup>a</sup>  
 עֵלָה }  
 עֵלָן } 97<sup>a</sup>; 112<sup>b</sup>  
 עֵלָן }  
 עֵלְקָה 1424<sup>a</sup>; 2144<sup>a</sup>; 3045<sup>b</sup>  
 עֵלִי 2348<sup>b</sup>  
 עֵלִי 928<sup>b</sup>; 1370<sup>b</sup>  
 עֵלִי 591<sup>b</sup>  
 עֵלִיָּה see עֵלְקָה  
 עֵלִיָּה 266<sup>b</sup>; 591<sup>b</sup>; 1437<sup>b</sup>;  
 3039<sup>a</sup>  
 עֵלִיוֹן 19<sup>a</sup>; 1205<sup>b</sup>; 1250<sup>a</sup>;  
 1251<sup>a</sup>; 1254<sup>a</sup>;  
 1264<sup>b</sup>; 1267<sup>a</sup>;  
 1390<sup>a</sup>  
 עֵלִיל 1149<sup>b</sup>  
 עֵלִילָה } 817<sup>a</sup>  
 עֵלִילָה }  
 עֵלִלָן see עֵלָן  
 עֵלִל 26<sup>b</sup>; 818<sup>a</sup>; 1234<sup>b</sup>;  
 3036<sup>a</sup>  
 עֵלִל see עֵלִלָל  
 עֵלִלָה see עֵלִילָה  
 עֵלָם 1560<sup>a</sup>  
 עֵלָם see עֵלָם  
 עֵלְמָה 891<sup>b</sup>; 1458<sup>a,b</sup>; 1967<sup>b</sup>;  
 3051<sup>b</sup>  
 עֵלְמוֹן 100<sup>a</sup>  
 עֵלְמוֹת 2096<sup>a</sup>; 2488<sup>a,b</sup>  
 עֵלְ-מִוִּת see מִוִּת לְבָן  
 עֵלְמוֹן } 100<sup>a</sup>  
 הַבְּלָתוּמָה }

עֲלָמָה	89 <sup>b</sup> ; 90 <sup>a</sup> ; 98 <sup>b</sup>	עֲמִשָּׂא	113 <sup>b</sup>	עֲפָעַם	797 <sup>b</sup>
עֲלֵע	2590 <sup>a</sup>	עֲמִשִּׁי	114 <sup>a</sup>	עֲפָר	817 <sup>b</sup>
עֲלָה	1086 <sup>b</sup>	עֲמִשְׁטִי	114 <sup>a</sup>	עֲפָר	955 <sup>b</sup>
עֵם	117 <sup>a</sup> ; 584 <sup>a</sup> ; 1121 <sup>b</sup> ; 1215 <sup>a</sup> ; 1570 <sup>b</sup> ; 1586 <sup>b</sup> ; 1593 <sup>a</sup> ; 2319 <sup>a</sup>	עֲנָב	128 <sup>a</sup>	עֲפָר	817 <sup>a, b</sup> ; 887 <sup>a</sup>
עֲמֹד	210 <sup>a</sup> ; 1559 <sup>a</sup> ; 1968 <sup>a</sup> ; 2558 <sup>a</sup> ; 2743 <sup>b</sup> ; 2745 <sup>b</sup>	עֲנָב	1122 <sup>b</sup> ; 2527 <sup>a</sup> ; 3050 <sup>a</sup>	עֲפָר	883 <sup>a</sup> ; 887 <sup>a</sup>
עֲמֹד	see עֲמֹד	עֲנָג	820 <sup>a</sup>	עֲפָרָה	see בֵּית לְעֲפָרָה
עֲמֹה	1338 <sup>a</sup> ; 2415 <sup>a</sup> ; 3033 <sup>a</sup>	עֲנָה	3 <sup>b</sup> ; 818 <sup>a</sup> ; 1051 <sup>b</sup> ; 1099 <sup>a</sup> ; 1215 <sup>b</sup> ; 2420 <sup>a</sup> ; 2488 <sup>b</sup> ; 2831 <sup>a</sup> ; 3036 <sup>a</sup> ; 3099 <sup>a</sup>	עֲפָרָה	964 <sup>a</sup> ; 2198 <sup>a</sup>
עֲמֹד	} 1984 <sup>b</sup> ; 2398 <sup>b</sup>	עֲנָה	128 <sup>a</sup> ; 2420 <sup>a</sup>	עֲפָרֹן	964 <sup>a</sup>
עֲמֹד		עֲנָי	2027 <sup>a</sup> ; 2420 <sup>a</sup>	עֲפָרָת	see עֲוֵפָרָת
עֲמוֹן	117 <sup>b</sup> ; 794 <sup>a</sup> ; 797 <sup>a</sup> ; 1931 <sup>a</sup>	עֲנִי	160 <sup>a</sup>	עֵץ	1335 <sup>b</sup> ; 1374 <sup>a</sup> ; 2183 <sup>a</sup> ; 2778 <sup>b</sup> ; 2847 <sup>b</sup> ; 2854 <sup>b</sup> ; 2972 <sup>a</sup> ; 3009 <sup>a</sup> ; 3155 <sup>b</sup>
עֲמוּנִי	117 <sup>b</sup>	עֲנוּב	160 <sup>a</sup>	עֵצָב	1305 <sup>b</sup> ; 1306 <sup>a</sup> ; 1547 <sup>a</sup> ; 1968 <sup>a</sup> ; 3110 <sup>a</sup> ; 3114 <sup>a</sup>
עֲמוּנִיה	118 <sup>a</sup>	עֲנוּהָ	1215 <sup>b</sup> ; 2027 <sup>a</sup>	עֵצָב	2426 <sup>a</sup>
עֲמוֹס	120 <sup>a</sup>	עֲנוּהָ	1439 <sup>b</sup> ; 2027 <sup>a</sup>	עֵצָה	65 <sup>a</sup>
עֲמוֹק	118 <sup>b</sup>	עֲנִי	66 <sup>a</sup>	עֲצִיזֹן נָבֵר	} 1082 <sup>a</sup>
עֲמִיאֵל	117 <sup>a</sup>	עֲנִי	2420 <sup>a, b</sup> ; 2427 <sup>a</sup>	עֲצִיזֹן	
עֲמִיהֹד	117 <sup>a</sup>	עֲנִי	3038 <sup>a</sup>	עֲצֵל	1447 <sup>b</sup> ; 2818 <sup>a</sup>
עֲמִיזָבֵד	117 <sup>b</sup>	עֲנִיהָ	128 <sup>b</sup>	עֲצָם	669 <sup>b</sup>
עֲמִיחֹר	117 <sup>a, b</sup>	עֲנִי	see עָנִי	עֲצָם	491 <sup>b</sup> ; 493 <sup>a</sup> ; 495 <sup>b</sup> ; 1081 <sup>b</sup>
עֲמִיקָרִיב	117 <sup>b</sup>	עֲנִים	136 <sup>a</sup>	עֲצָם	495 <sup>b</sup> ; 1144 <sup>b</sup>
עֲמִיר	1334 <sup>b</sup> ; 2752 <sup>a</sup>	עֲנָן	533 <sup>a</sup> ; 896 <sup>b</sup> ; 3007 <sup>a</sup>	עֲצָמָה	17 <sup>b</sup>
עֲמִישִׁיעִי	117 <sup>b</sup>	עֲנָם	132 <sup>a</sup>	עֲצָמוֹן	} 345 <sup>a</sup>
עֲמִית	1106 <sup>a</sup>	עֲנָמִים	129 <sup>a</sup>	עֲצָמוֹן	
עֲמֵל	3007 <sup>a</sup>	עֲנָמְלָאָה	61 <sup>b</sup> ; 129 <sup>a</sup>	עֲצָן	1082 <sup>a</sup>
עֲמֵל	1306 <sup>b</sup>	עֲנָן	331 <sup>a</sup> ; 522 <sup>b</sup> ; 862 <sup>a</sup> ; 942 <sup>b</sup> ; 2033 <sup>b</sup>	עֲצָר	669 <sup>b</sup> ; 2569 <sup>b</sup>
עֲמֵל	112 <sup>b</sup>	עֲנָן	129 <sup>a</sup> ; 670 <sup>a</sup>	עֲצָרָה	} 701 <sup>a</sup> ; 2822 <sup>a</sup>
עֲמֵלֵק	112 <sup>b</sup>	עֲנָנִי	129 <sup>a</sup>	עֲצָרָת	
עֲמֵלְקִי	112 <sup>b</sup>	עֲנָנִיהָ	129 <sup>a</sup>	עֲקָב	1549 <sup>a</sup>
עֲמִנְיָאֵל	1457 <sup>b</sup>	עֲנָה	513 <sup>b</sup>	עֲקָב	1549 <sup>a</sup>
עֲמִס	} 1354 <sup>a</sup>	עֲנָה	513 <sup>b</sup>	עֲקָב	} 1367 <sup>a</sup>
עֲמִשׁ		עֲנָם	513 <sup>b</sup>	עֲקָבָה	
עֲמִסְיָה	114 <sup>a</sup>	עֲנָק	589 <sup>a</sup> ; 2999 <sup>a</sup>	עֲקָבָה	2868 <sup>a</sup>
עֲמִעַד	112 <sup>b</sup>	עֲנָקָר	128 <sup>b</sup>	עֲקָד	see בֵּית עֲקָד
עֲמִק	439 <sup>a</sup> ; 777 <sup>b</sup> ; 1583 <sup>a, b</sup> ; 1808 <sup>a, b</sup> ; 2092 <sup>a</sup> ; 2560 <sup>a</sup> ; 2751 <sup>a</sup> ; 2784 <sup>a</sup> ; 3045 <sup>a, b</sup>	עֲנָר	132 <sup>b</sup>	עֲקָד	2594 <sup>b</sup>
עֲמִלֵק	3045 <sup>a</sup>	עֲנָשׁ	698 <sup>a</sup> ; 1132 <sup>b</sup> ; 2093 <sup>b</sup>	עֲקָרִב	89 <sup>a</sup> ; 1549 <sup>a</sup>
עֲמִר	2035 <sup>a</sup>	עֲנָשׁ	2504 <sup>b</sup> ; 3010 <sup>b</sup>	עֲקָלְקֵל	760 <sup>b</sup>
עֲמִר	1067 <sup>a</sup> ; 2188 <sup>b</sup> ; 2257 <sup>a</sup> ; 2752 <sup>a</sup> ; 3080 <sup>a</sup>	עֲנָת	130 <sup>a</sup> ; 442 <sup>a</sup> ; 2748 <sup>b</sup>	עֲקָלְחוֹן	309 <sup>a</sup> ; 760 <sup>b</sup>
עֲמִרָה	1277 <sup>a</sup>	עֲנָתוֹת	130 <sup>b</sup>	עֲקָן	88 <sup>b</sup>
עֲמִרִי	2191 <sup>b</sup>	עֲנָתוֹתִי	130 <sup>b</sup> ; 144 <sup>b</sup>	עֲקָר	1402 <sup>b</sup>
עֲמִרָם	125 <sup>b</sup>	עֲסִים	1780 <sup>b</sup> ; 2140 <sup>b</sup> ; 3086 <sup>b</sup>	עֲקָר	916 <sup>a</sup>
עֲמִרְמִי	126 <sup>a</sup>	עֲפָל	2438 <sup>b</sup>	עֲקָר	406 <sup>a</sup>
עֲמִשׁ	see עֲמִס	עֲפָל	940 <sup>b</sup> ; 1392 <sup>a</sup> ; 3027 <sup>b</sup>	עֲקָרָב	2703 <sup>a</sup>
		עֲפָל	2196 <sup>b</sup>	עֲקָרוֹן	27 <sup>b</sup> ; 916 <sup>a</sup>
		עֲפָרִי	2198 <sup>a</sup>	עֲקָשׁ	760 <sup>b</sup> ; 2348 <sup>a</sup>



פָּה	33 <sup>b</sup> ; 674 <sup>a</sup> ; 679 <sup>b</sup> ; 728 <sup>b</sup> ; 899 <sup>a</sup> ; 2093 <sup>a</sup> ; 2422 <sup>b</sup> ; 2814 <sup>b</sup> ; 3096 <sup>b</sup>	פִּינָן	2400 <sup>a</sup>	פְּלִשְׁתָּא	2208 <sup>b</sup> ; 2376 <sup>a</sup>
פּוּאָה	} 2501 <sup>a</sup>	פִּישׁוֹן	2400 <sup>b</sup>	פְּלִשְׁתֵּי	2026 <sup>b</sup> ; 2297 <sup>b</sup> ; 2376 <sup>a,b</sup> ; 2963 <sup>a</sup>
פִּינָה		פִּיתוֹן	2402 <sup>a</sup>	פְּלִתָּה	2297 <sup>a</sup>
פּוּחַ	490 <sup>b</sup>	פִּי	512 <sup>a</sup> ; 1231 <sup>b</sup> ; 2425 <sup>b</sup> ; 3049 <sup>a</sup>	פְּלִתֵּי	255 <sup>b</sup> ; 2297 <sup>a</sup> ; 2379 <sup>a,b</sup>
פּוּט	2392 <sup>b</sup> ; 2511 <sup>a</sup>	פִּכְרַת צְבָרִים	1443 <sup>b</sup> ; 2410 <sup>a</sup>	פֶּסֶם	2093 <sup>a</sup>
פּוּטִיאַל	2511 <sup>a</sup>	פִּלָּא	1337 <sup>b</sup> ; 1389 <sup>a</sup> ; 2001 <sup>a</sup> ; 2062 <sup>b</sup> ; 2403 <sup>a</sup> ; 2805 <sup>a</sup> ; 3104 <sup>b</sup>	פֶּסֶג	2237 <sup>b</sup>
פּוּטִיפּר	2423 <sup>a</sup>	פִּלָּא	2062 <sup>b</sup> ; 3104 <sup>b</sup>	פֶּסְנָה	706 <sup>a</sup> ; 797 <sup>b</sup>
פּוּקָה	674 <sup>b</sup> ; 1087 <sup>b</sup> ; 1234 <sup>b</sup> ; 1793 <sup>a</sup> ; 2208 <sup>a</sup>	פִּלְאִיָּה	see פְּלִיָּה	פֶּסְנִים	see פְּנִים
פּוּל	417 <sup>b</sup>	פִּלְאָסְר	see תְּגִלַּת פִּלְאָסְר	פֶּסְנָה	721 <sup>b</sup> ; 722 <sup>a</sup> ; 1137 <sup>a</sup> ; 1435 <sup>b</sup> ; 1607 <sup>b</sup>
פּוּנִי	2506 <sup>a</sup>	פִּלְג	2296 <sup>b</sup> ; 2866 <sup>b</sup>	פְּנוּאָל	} 2298 <sup>a</sup> ; 2358 <sup>b</sup>
פּוּנָן	2506 <sup>a</sup>	פִּלְג	2296 <sup>b</sup>	פְּנוּאָל	
פּוּעִיָּה	2501 <sup>a</sup>	פִּלְג	2296 <sup>b</sup> ; 2595 <sup>a</sup> ; 2866 <sup>b</sup> ; 2899 <sup>b</sup> ; 3074 <sup>b</sup>	פְּנִי	see פְּנִין
פּוּק	1150 <sup>b</sup>	פִּלְגָּה	2595 <sup>a</sup>	פְּנִים	723 <sup>b</sup> ; 1085 <sup>b</sup> ; 1127 <sup>b</sup> ; 1131 <sup>a</sup> ; 1141 <sup>a</sup> ; 1253 <sup>a</sup> ; 1354 <sup>b</sup> ; 1418 <sup>b</sup> ; 2337 <sup>a</sup> ; 2438 <sup>a</sup> ; 2561 <sup>b</sup> ; 2767 <sup>a</sup>
פּוּקָה	1306 <sup>a</sup>	פִּלְגָּשׁ	see פִּילְגָּשׁ	פְּנִימִי	2932 <sup>b</sup>
פּוּר	2156 <sup>b</sup>	פִּלְהֵשׁ	2398 <sup>b</sup>	פְּנִין	} 709 <sup>a</sup> ; 2860 <sup>a</sup> ; 2861 <sup>a,b</sup>
פּוּר	} 2506 <sup>b</sup>	פִּלְהָה	2744 <sup>b</sup>	פְּנִי	
פּוּרִים		פִּלְוִיא	2235 <sup>a</sup> ; 2358 <sup>b</sup>	פְּנִיָּה	2298 <sup>a</sup>
פּוּרִים	} 2506 <sup>b</sup>	פִּלְוִי	2297 <sup>b</sup>	פְּסָג	2400 <sup>b</sup>
פּוּרָה		פִּלְח	316 <sup>b</sup> ; 2409 <sup>b</sup>	פְּסָנָה	2400 <sup>a</sup>
פּוּרְתָא	2421 <sup>a</sup>	פִּלְחָא	2398 <sup>b</sup>	פְּסָה	1334 <sup>b</sup>
פּוּרְתֵי	2501 <sup>b</sup> ; 2511 <sup>a</sup>	פִּלְחָן	2742 <sup>b</sup>	פְּסָח	962 <sup>b</sup> ; 1323 <sup>b</sup>
פּוּז	1111 <sup>a</sup> ; 1274 <sup>a</sup>	פִּלְחָט	1148 <sup>a</sup>	פְּסָח	889 <sup>a</sup> ; 2256 <sup>a</sup>
פּוּזָה	441 <sup>b</sup>	פִּלְחָט	2297 <sup>a</sup>	פְּסָחָה	2255 <sup>a</sup> ; 2365 <sup>b</sup>
פּוּח	1441 <sup>a, b</sup> ; 2408 <sup>a</sup> ; 2819 <sup>a</sup>	פִּלְחָט	see פְּלִיט	פְּסָחָה	1823 <sup>b</sup>
פּוּחַד	1102 <sup>a</sup> ; 2856 <sup>a</sup>	פִּלְחָטָה	see פְּלִיטָה	פְּסָחָה	581 <sup>b</sup> ; 2512 <sup>b</sup>
פּוּחָה	569 <sup>a</sup> ; 1289 <sup>b</sup> ; 1969 <sup>b</sup> ; 2681 <sup>a</sup> ; 2986 <sup>b</sup> ; 2987 <sup>a</sup>	פִּלְחָטִי	2236 <sup>b</sup> ; 2358 <sup>b</sup>	פְּסָחָה	2255 <sup>a</sup>
פּוּחָם	671 <sup>b</sup> ; 672 <sup>a</sup>	פִּלְחָטִי	2399 <sup>a</sup>	פְּסָחָה	2512 <sup>b</sup>
פּוּחַת	1146 <sup>a</sup> ; 2401 <sup>b</sup> ; 2681 <sup>b</sup>	פִּלְחָטִיָּל	2236 <sup>b</sup> ; 2358 <sup>b</sup>	פְּסָחָה	2512 <sup>b</sup>
פּוּחַת מוּאָב	474 <sup>b</sup> ; 2207 <sup>a</sup>	פִּלְחָטִיָּה	} 2296 <sup>b</sup>	פְּסָחָה	581 <sup>b</sup> ; 1450 <sup>a</sup> ; 2512 <sup>b</sup>
פּוּחַתָּה	1146 <sup>a</sup>	פִּלְחָטִיָּה		2296 <sup>b</sup>	פְּסָחָרִין
פּוּחַדָּה	709 <sup>a</sup> ; 2856 <sup>b</sup> ; 2857 <sup>a</sup>	פִּלְחָטִיָּה	} 1148 <sup>a</sup>	פְּסָחָרִין	
פּוּחַדִּי	2861 <sup>a</sup> ; 2862 <sup>a</sup>	פִּלְחָטִי		1148 <sup>a</sup>	פְּסָחָה
פּוּחַשׁ	518 <sup>b</sup> ; 1325 <sup>b</sup>	פִּלְחָט	} 755 <sup>a</sup>	פְּעוּ	} 2207 <sup>a</sup>
פּוּחַר	} 2453 <sup>a</sup>	פִּלְחָט		755 <sup>a</sup>	
פּוּחַרָּה		פִּלְחָטָה	859 <sup>b</sup>	פִּלְחָטָה	see פְּעוּר
פּוּחַסְתָּ	2366 <sup>a</sup> ; 2394 <sup>b</sup>	פִּלְחָטָה	2208 <sup>a</sup>	פְּעֵל	1968 <sup>a, b</sup> ; 3105 <sup>b</sup>
פּוּחַסְתָּ	1825 <sup>a</sup>	פִּלְחָטָה	2296 <sup>b</sup>	פְּעֵל	817 <sup>a</sup> ; 1221 <sup>a</sup> ; 1968 <sup>b</sup>
פּוּחַת הַיְהוּדִים	2396 <sup>a</sup>	פִּלְחָטָה	} 2296 <sup>b</sup>	פְּעֵלָה	3063 <sup>a</sup>
פּוּחַל	2366 <sup>a</sup>	פִּלְחָטָה		2296 <sup>b</sup>	פְּעֵלָתֵי
פִּילְגָּשׁ	} 2247 <sup>a</sup>	פִּלְחָטָה	} see תְּגִלַּת פִּ	פְּעֵם	} 160 <sup>a</sup> ; 2200 <sup>a</sup> ; 3083 <sup>b</sup>
פִּילְגָּשׁ		פִּלְחָטָה		פִּלְחָטָה	
פִּימָה	674 <sup>b</sup>	פִּלְחָטָה	379 <sup>b</sup> ; 2701 <sup>b</sup>	פְּעֵמָן	432 <sup>a</sup>
פִּינְחָס	768 <sup>b</sup> ; 1421 <sup>a</sup> ; 2385 <sup>b</sup>	פִּלְחָטָה	1102 <sup>a</sup> ; 1423 <sup>a</sup>	פְּעֵרִי	2206 <sup>a</sup>
		פִּלְחָטָה	449 <sup>a</sup>		

- פָּצַח 517<sup>b</sup>; 2154<sup>b</sup>  
 פָּצִירָה 1110<sup>a</sup>  
 פָּעֵלָה 2864<sup>a</sup>  
 פָּעִץ see פָּעִץ בֵּית  
 פָּקַד 210<sup>a</sup>; 680<sup>a</sup>; 688<sup>a</sup>;  
 1968<sup>a</sup>; 2200<sup>b</sup>;  
 2205<sup>b</sup>  
 פָּקַד see פָּקִיד  
 פָּקִידָה 595<sup>a</sup>; 769<sup>a</sup>; 2180<sup>b</sup>;  
 3058<sup>a</sup>  
 פָּקִיד 2296<sup>b</sup>  
 פָּקִיד }  
 פָּקִיד } 2434<sup>b</sup>  
 פָּקִד }  
 פָּקַח 2295<sup>a</sup>  
 פָּקַח 3089<sup>a</sup>  
 פָּקַחָה 2296<sup>a</sup>  
 פָּקִיד 1289<sup>b</sup>; 1852<sup>a,b</sup>;  
 2180<sup>b</sup>; 3134<sup>b</sup>  
 פָּקַע 1286<sup>b</sup>; 1815<sup>b</sup>  
 פָּקַעָה 935<sup>b</sup>; 1286<sup>b</sup>  
 פָּק }  
 פָּק } 546<sup>b</sup>  
 פָּקָא }  
 פָּקָה } 287<sup>a</sup>  
 פָּקָה see פָּקָא  
 פָּקָם 2400<sup>a</sup>  
 פָּקָר }  
 פָּקָר } 2247<sup>a</sup>  
 פָּקָר }  
 פָּקָר 316<sup>b</sup>; 2744<sup>b</sup>  
 פָּקָה 2093<sup>b</sup>  
 פָּקָם 896<sup>b</sup>; 1132<sup>a</sup>; 2199<sup>a</sup>;  
 2246<sup>a</sup>; 2248<sup>b</sup>;  
 2831<sup>b</sup>  
 פָּקָה 734<sup>a</sup>; 1367<sup>b</sup>; 1799<sup>a</sup>;  
 2247<sup>a</sup>  
 פָּקָה see פָּקָא  
 פָּקִידָא }  
 פָּקִידָא } 2323<sup>a</sup>; 2712<sup>b</sup>  
 פָּקִידָה 2255<sup>a</sup>  
 פָּקִידָה 2255<sup>a</sup>  
 פָּקִיד 2237<sup>b</sup>; 2423<sup>a</sup>; 2425<sup>b</sup>  
 פָּקִיד see פָּקִיד  
 פָּקִידָה 3001<sup>a</sup>; 3049<sup>b</sup>  
 פָּקִידָה 3049<sup>b</sup>  
 פָּקִיד 2323<sup>a</sup>  
 פָּקִיד 517<sup>b</sup>; 1120<sup>a</sup>  
 פָּקִיד 1120<sup>b</sup>; 3050<sup>a</sup>  
 פָּקִיד 594<sup>a</sup>  
 פָּקִיד 1273<sup>b</sup>  
 פָּקִידָא see פָּקִידָה
- פָּרִים see פָּרִי  
 פָּרִיץ 2533<sup>b</sup>  
 פָּרָךְ 763<sup>b</sup>  
 פָּרָכָה 1336<sup>a</sup>; 3047<sup>a</sup>  
 פָּרְמִשְׁתָּא 2248<sup>b</sup>  
 פָּרְנָךְ 2248<sup>b</sup>  
 פָּרַס 2032<sup>a</sup>; 3038<sup>b</sup>  
 פָּרַס 2202<sup>b</sup>  
 פָּרַס 2032<sup>a</sup>; 2329<sup>a</sup>; 2335<sup>a</sup>  
 פָּרַסָה 667<sup>a</sup>  
 פָּרַסִי 2335<sup>a</sup>  
 פָּרַע 340<sup>a</sup>; 1055<sup>b</sup>; 2111<sup>a</sup>  
 פָּרַע 1907<sup>a,b</sup>  
 פָּרַעָה 1055<sup>b</sup>  
 פָּרַעָה 2359<sup>a</sup>  
 פָּרַעָה הַפָּרַע 2359<sup>b</sup>  
 פָּרַעָה נָחָה }  
 פָּרַעָה נָחָה } 2360<sup>a</sup>  
 פָּרַעָה נָחָה }  
 פָּרַעֶשׁ 1118<sup>b</sup>; 2248<sup>b</sup>; 2365<sup>b</sup>  
 פָּרַעְהוֹן 2360<sup>b</sup>; 2400<sup>a</sup>  
 פָּרַפַּר 316<sup>a</sup>; 2365<sup>b</sup>  
 פָּרַץ 517<sup>b</sup>; 695<sup>b</sup>; 1143<sup>b</sup>;  
 1968<sup>a</sup>  
 פָּרַץ 514<sup>b</sup>; 1173<sup>b</sup>; 2320<sup>b</sup>  
 פָּרַצִי 2365<sup>b</sup>  
 פָּרַצִים 2320<sup>a</sup>  
 פָּרַק 517<sup>a</sup>; 525<sup>a</sup>; 2541<sup>a</sup>  
 פָּרַק 762<sup>a</sup>  
 פָּרַר 746<sup>a</sup>  
 פָּרַשׁ 614<sup>a</sup>; 859<sup>b</sup>; 1147<sup>b</sup>;  
 2846<sup>b</sup>  
 פָּרַשׁ 2032<sup>a</sup>; 2854<sup>b</sup>  
 פָּרַשׁ 882<sup>b</sup>; 2320<sup>b</sup>  
 פָּרַשׁ 1423<sup>a,b</sup>; 2032<sup>b</sup>  
 פָּרַשׁ-בְּדָתָא 2251<sup>b</sup>  
 פָּרַת 897<sup>b</sup>; 1038<sup>b</sup>  
 פָּרַתָם 2154<sup>a</sup>  
 פָּשׁ 1069<sup>b</sup>  
 פָּשְׁחוּר 2255<sup>a</sup>  
 פָּשַׁע 340<sup>a</sup>; 2179<sup>b</sup>  
 פָּשַׁע 2798<sup>b</sup>; 3006<sup>b</sup>  
 פָּשַׁת 1118<sup>a</sup>; 1894<sup>a</sup>  
 פָּשַׁתָה 1118<sup>a</sup>; 3000<sup>b</sup>  
 פָּת }  
 פָּתָה } 1393<sup>b</sup>; 1436<sup>a</sup>  
 פָּתָה see פָּתִי  
 פָּתָם 896<sup>b</sup>  
 פָּתָה 99<sup>b</sup>; 816<sup>a</sup>; 2712<sup>a</sup>;  
 2798<sup>a</sup>
- פָּתוּאָל 2358<sup>a</sup>  
 פָּתוּחַ }  
 פָּתוּחַ } 581<sup>b</sup>  
 פָּתוּחַ }  
 פָּתוּר 2358<sup>a</sup>  
 פָּתַח 517<sup>b</sup>; 2196<sup>b</sup>  
 פָּתַח 869<sup>a</sup>; 1175<sup>b</sup>; 1435<sup>b</sup>;  
 2196<sup>b</sup>  
 פָּתַחָה 2358<sup>a</sup>  
 פָּתִי }  
 פָּתִי } 1125<sup>a</sup>; 2798<sup>a</sup>  
 פָּתִי }  
 פָּתִי }  
 פָּתִיגִיל 2856<sup>a</sup>  
 פָּתִיחַת 2798<sup>a</sup>  
 פָּתִיל 512<sup>b</sup>; 513<sup>a</sup>; 1819<sup>b</sup>;  
 2590<sup>a</sup>  
 פָּתִלְתָל 760<sup>b</sup>  
 פָּתָם 2401<sup>b</sup>  
 פָּתָן 55<sup>a</sup>; 286<sup>b</sup>; 2737<sup>b</sup>;  
 2738<sup>a</sup>  
 פָּתָרוּס 2263<sup>a</sup>  
 פָּתָרִסִי 2263<sup>a</sup>  
 פָּתַת 517<sup>b</sup>  
 פָּתַת  
 פָּתַת see פָּתַת  
 פָּתַת see פָּתַת  
 פָּתַת 1931<sup>b</sup>  
 פָּתַת }  
 פָּתַת } 583<sup>b</sup>; 584<sup>a,b</sup>; 1822<sup>b</sup>;  
 פָּתַת } 2756<sup>b</sup>; 2758<sup>a</sup>  
 פָּתַת 1542<sup>b</sup>  
 פָּתַת 1106<sup>b</sup>; 1905<sup>a,b</sup>;  
 1906<sup>a</sup>; 1907<sup>a</sup>;  
 2999<sup>b</sup>  
 פָּתַת }  
 פָּתַת } 254<sup>b</sup>; 1254<sup>b</sup>; 1264<sup>b</sup>;  
 פָּתַת } 1267<sup>b</sup>; 1433<sup>b</sup>;  
 פָּתַת } 1919<sup>a</sup>; 2188<sup>b</sup>;  
 פָּתַת } 2742<sup>a</sup>; 3148<sup>b</sup>  
 פָּתַת  
 פָּתַת 3134<sup>a</sup>  
 פָּתַת }  
 פָּתַת }  
 פָּתַת 132<sup>b</sup>; 2875<sup>a</sup>  
 פָּתַת see פָּתַת  
 פָּתַת 1443<sup>b</sup>  
 פָּתַת 2597<sup>a</sup>; 3085<sup>a</sup>  
 פָּתַת 144<sup>a</sup>; 817<sup>a,b</sup>; 1179<sup>a</sup>;  
 1235<sup>b</sup>; 3155<sup>b</sup>;  
 3156<sup>a</sup>  
 פָּתַת 3148<sup>b</sup>  
 פָּתַת 3148<sup>b</sup>  
 פָּתַת 817<sup>a,b</sup>; 1179<sup>a</sup>; 2597<sup>a</sup>  
 פָּתַת see פָּתַת



צָבַע 1444<sup>a</sup>  
 צָבַע 883<sup>b</sup>  
 צָבְעוֹן 1443<sup>b</sup>; 3148<sup>b</sup>  
 צָבָעִים 1443<sup>b</sup>  
 צָבַר 1350<sup>b</sup>  
 צָבַח 528<sup>a</sup>  
 צָד 1886<sup>a</sup>  
 צָדַד 3140<sup>b</sup>  
 צָדָה 1370<sup>b</sup>  
 צָדָה see צִדְדָה  
 צָדוּק 3129<sup>b</sup>  
 צָדִים 3149<sup>a</sup>  
 צָדִיק 1264<sup>b</sup>; 1267<sup>b</sup>; 1858<sup>a</sup>;  
 2591<sup>a</sup>; 2795<sup>a</sup>;  
 3129<sup>b</sup>  
 צָדִק 1267<sup>b</sup>; 1782<sup>b</sup>; 3129<sup>b</sup>  
 צָדִק 1781<sup>b</sup>; 1782<sup>b</sup>; 2591<sup>a</sup>  
 צָדִיקָה 1781<sup>b</sup>; 2073<sup>a</sup>; 2591<sup>a</sup>;  
 2681<sup>b</sup>  
 צָדִיקָה } 80<sup>a</sup>; 3141<sup>a</sup>  
 צָדִיקָה }  
 צָדִל 2132<sup>b</sup>  
 צָדָה 1311<sup>a</sup>  
 צָדָה 2049<sup>a</sup>; 2155<sup>a</sup>; 2200<sup>b</sup>  
 צָד }  
 צָד } 2434<sup>b</sup>  
 צָד }  
 צָדָה } 1110<sup>b</sup>  
 צָדָה }  
 צָדָר }  
 צָדָר } 2129<sup>a</sup>  
 צָדָר }  
 צָדָרָה }  
 צָדָרָה }  
 צָדָה } 1325<sup>a</sup>; 3154<sup>b</sup>  
 צָדָה }  
 צָדָה }  
 צָדָד 3047<sup>b</sup>  
 צָדָה 210<sup>a</sup>; 1127<sup>a</sup>; 2200<sup>b</sup>;  
 2201<sup>a</sup>; 3150<sup>b</sup>  
 צָדָה 695<sup>b</sup>  
 צָדָם 1099<sup>a</sup>  
 צָדָם } 1103<sup>a</sup>  
 צָדָם }  
 צָדָר 3158<sup>b</sup>  
 צָדָה 2227<sup>a</sup>  
 צָדָה }  
 צָדָה } 3156<sup>b</sup>; 3158<sup>b</sup>; 3159<sup>a</sup>  
 צָדָה }  
 צָדָה } 3156<sup>b</sup>  
 צָדָה see צָדָה

צוּפֵר 3156<sup>b</sup>  
 צוּץ 1120<sup>a</sup>; 2766<sup>b</sup>  
 צוּק 136<sup>a</sup>  
 צוּר { 288<sup>b</sup>; 1098<sup>b</sup>; 1136<sup>a,b</sup>;  
 1254<sup>b</sup>; 1264<sup>b</sup>;  
 1569<sup>b</sup>; 2189<sup>a</sup>;  
 2596<sup>a</sup>; 2856<sup>a</sup>;  
 3146<sup>b</sup>; 3159<sup>a</sup>  
 צוּר see צָר  
 צוּר see צָרָא  
 צוּרָה 1136<sup>a</sup>  
 צוּרָן see צָרָא  
 צוּרָאֵל 3159<sup>a</sup>  
 צוּרֵשֶׁתִי 3159<sup>b</sup>  
 צוּח 676<sup>a</sup>  
 צוּחָא see צִיחָא  
 צוּחָה 2247<sup>b</sup>  
 צוּחִיתָה 2247<sup>b</sup>  
 צוּחַק 1168<sup>b</sup>; 1317<sup>a</sup>; 1493<sup>b</sup>;  
 1843<sup>b</sup>; 2072<sup>b</sup>  
 צוּחַק 1843<sup>b</sup>; 2703<sup>a</sup>  
 צוּחַר 3154<sup>b</sup>  
 צוּחַר 287<sup>a</sup>; 676<sup>a</sup>  
 צוּי 1548<sup>a, b</sup>; 2774<sup>a</sup>;  
 2775<sup>b</sup>; 3076<sup>a</sup>;  
 3084<sup>a</sup>  
 צוּד 1440<sup>a</sup>; 3047<sup>b</sup>  
 צוּדָה } 3047<sup>b</sup>  
 צוּדָה }  
 צוּדוֹן } 2785<sup>a</sup>  
 צוּדוֹן }  
 צוּדָה 406<sup>a</sup>; 831<sup>b</sup>; 1548<sup>b</sup>;  
 3084<sup>b</sup>  
 צוּדִין 2988<sup>b</sup>  
 צוּדִין 3150<sup>b</sup>  
 צוּדָה } 3149<sup>a</sup>  
 צוּדָה }  
 צוּדִי 582<sup>b</sup>; 2697<sup>a</sup>  
 צוּדַעַר 3152<sup>b</sup>  
 צוּדָה see צוּדָה  
 צוּדָה } 1120<sup>b</sup>; 2408<sup>a</sup>; 3153<sup>a</sup>  
 צוּדָה }  
 צוּדָה 1120<sup>b</sup>  
 צוּדָה 128<sup>a</sup>; 1146<sup>b</sup>; 1907<sup>a</sup>;  
 2917<sup>b</sup>  
 צוּדָלַג see צָקָלַג  
 צוּר 115<sup>a</sup>; 1436<sup>a</sup>; 2207<sup>a, b</sup>  
 צוּל 2745<sup>b</sup>  
 צוּלָה 3149<sup>a</sup>  
 צוּלָה } 517<sup>b</sup>; 678<sup>b</sup>; 2027<sup>b</sup>  
 צוּלָה }

צוּלָה 2237<sup>b</sup>  
 צוּלָחִיה 764<sup>b</sup>; 2237<sup>b</sup>  
 צוּלָחַת 504<sup>a</sup>; 854<sup>b</sup>  
 צוּלָל 510<sup>b</sup>; 1907<sup>b</sup>  
 צוּלָפּוּנִי 1348<sup>a</sup>  
 צוּלָם 145<sup>b</sup>; 146<sup>a</sup>; 1109<sup>b</sup>;  
 1136<sup>a</sup>; 1264<sup>b</sup>;  
 1450<sup>a</sup>; 1452<sup>a</sup>;  
 1454<sup>a</sup>; 2766<sup>b</sup>  
 צוּלָמוֹן 3131<sup>b</sup>  
 צוּלָמֶנָה 2746<sup>a</sup>  
 צוּלָמֶנָה 3131<sup>b</sup>  
 צוּלָמֶנֶע 3133<sup>b</sup>  
 צוּלָע 1323<sup>b</sup>  
 צוּלָע 64<sup>b</sup>; 2590<sup>a</sup>; 3142<sup>b</sup>  
 צוּלָע } 417<sup>a</sup>; 591<sup>b</sup>; 1861<sup>b</sup>;  
 צוּלָע } 2590<sup>a</sup>  
 צוּלָה 3131<sup>b</sup>  
 צוּלָפּוּר 3143<sup>a</sup>  
 צוּלָצָה 3143<sup>a</sup>  
 צוּלָצַל 1907<sup>b</sup>; 1908<sup>b</sup>; 2095<sup>a</sup>;  
 2097<sup>a</sup>; 2101<sup>a</sup>  
 צוּלָק 3143<sup>a</sup>  
 צוּלָחִי 3149<sup>b</sup>  
 צוּם see צוּם  
 צוּמָא 2595<sup>b</sup>; 2973<sup>a</sup>  
 צוּמָא 2973<sup>a</sup>  
 צוּמָד 38<sup>a</sup>; 287<sup>b</sup>; 724<sup>b</sup>;  
 3127<sup>a</sup>  
 צוּמָה 1320<sup>b</sup>; 1907<sup>b</sup>; 3047<sup>a</sup>  
 צוּמֶרַק 528<sup>a</sup>; 671<sup>a</sup>; 1123<sup>a</sup>;  
 2527<sup>a</sup>  
 צוּמָח 513<sup>b</sup>  
 צוּמִיד } 512<sup>b</sup>; 513<sup>a</sup>; 733<sup>a</sup>  
 צוּמִיד }  
 צוּמִיר 2595<sup>b</sup>  
 צוּמִיר 3104<sup>b</sup>  
 צוּמִיר 3143<sup>a</sup>  
 צוּמִירִים 3143<sup>a</sup>  
 צוּמִירָה 513<sup>b</sup>; 1390<sup>a</sup>  
 צוּמִת 769<sup>b</sup>  
 צוּן 3066<sup>a</sup>; 3150<sup>a, b</sup>  
 צוּן 2974<sup>b</sup>  
 צוּנָא } see צוּנָן  
 צוּנָה }  
 צוּנָה 252<sup>b</sup>; 253<sup>a</sup>; 728<sup>b</sup>;  
 1116<sup>a</sup>; 1419<sup>a</sup>;  
 2787<sup>b</sup>  
 צוּנָר 1435<sup>b</sup>; 1609<sup>a</sup>; 3074<sup>b</sup>;  
 3075<sup>a</sup>

צָרִיךְ } 2974 <sup>b</sup>	צָפְתָה 3146 <sup>a</sup>	קְבֻרוֹת } 1797 <sup>a</sup> ; 1942 <sup>a</sup>
צָרִיךְ }	צָרַץ see צָרַץ	קְבֻרָה } 762 <sup>a</sup>
צָרוּחַ } 841 <sup>a</sup> ; 878 <sup>b</sup> ; 1343 <sup>b</sup>	צָקְלַג } 3149 <sup>a</sup>	קְדָה 582 <sup>a</sup>
צָרוּפָה }	צָר } 64 <sup>b</sup> ; 136 <sup>a</sup> ; 944 <sup>b</sup> ;	קְדוּם 1813 <sup>b</sup>
צָרִיךְ see צָרִיךְ	צָר } 1370 <sup>b</sup> ; 2864 <sup>a</sup>	קְדוּשׁ } 35 <sup>a</sup> ; 132 <sup>b</sup> ; 1264 <sup>b</sup> ;
צָרִיחַ 841 <sup>a</sup> ; 1343 <sup>b</sup> ; 2067 <sup>b</sup>	צָר 3146 <sup>b</sup>	קְדִישׁ } 1403 <sup>b</sup> ; 1596 <sup>b</sup> ;
צָרְעָנָה 2423 <sup>a</sup>	צָר } 1119 <sup>b</sup> ; 3030 <sup>b</sup>	קְדִישׁ } 2078 <sup>b</sup> ; 2661 <sup>a, b</sup>
צָרְתָה 3075 <sup>a</sup>	צָר } 3140 <sup>b</sup>	קְדָה 2860 <sup>a, b</sup>
צָעַד 522 <sup>b</sup>	צָרְתָה } 3140 <sup>b</sup>	קְדָמָה 78 <sup>a</sup> ; 1107 <sup>b</sup>
צָעַד 2206 <sup>a</sup>	צָרָה 64 <sup>b</sup> ; 1611 <sup>b</sup> ; 3010 <sup>b</sup>	קְדִישׁ 2661 <sup>a</sup>
צָעֲדָה 1578 <sup>b</sup> ; 1865 <sup>a</sup>	צָרוּחַ 3148 <sup>a</sup>	קְדָם 160 <sup>a</sup> ; 888 <sup>b</sup> ; 2438 <sup>b</sup>
צָעָה 1052 <sup>b</sup>	צָרוּעָה 3147 <sup>b</sup>	קְדָם } 130 <sup>b</sup> ; 888 <sup>b</sup> ; 1041 <sup>a</sup> ;
צָעִיחַ 3047 <sup>a</sup>	צָרוּר } 377 <sup>b</sup> ; 528 <sup>a</sup> ; 2856 <sup>a</sup> ;	קְדָמָה } 1141 <sup>a</sup> ; 1789 <sup>a</sup> ;
צָעִיר 3131 <sup>b</sup>	צָרָה } 3147 <sup>b</sup>	קְדָמָה } 1790 <sup>a, b</sup> ; 3042 <sup>b</sup>
צָעִן 3153 <sup>a</sup>	צָרִי } 381 <sup>a</sup> ; 3147 <sup>b</sup>	קְדָם 2438 <sup>a</sup>
צָעֲנָנִים } 3128 <sup>a</sup>	צָרִי }	קְדָמָה 160 <sup>a</sup>
צָעֲנָנִים }	צָרַע 1422 <sup>b</sup>	קְדָמָה see קְדָם
צָעֶק 764 <sup>b</sup> ; 1490 <sup>b</sup>	צָרְעָה 1422 <sup>b</sup>	קְדָמוּנִי } 131 <sup>a</sup> ; 1136 <sup>b</sup> ; 1789 <sup>a</sup> ;
צָעַר 3154 <sup>a</sup>	צָרְעָה 1422 <sup>b</sup> ; 3132 <sup>b</sup> ; 3157 <sup>a</sup>	קְדָמוּנִי } 2026 <sup>b</sup>
צָפָה 3074 <sup>a</sup>	צָרְעָתִי 3157 <sup>a</sup>	קְדָמוֹת 1790 <sup>b</sup>
צָפוֹ } 3146 <sup>a</sup>	צָרְעָתִי 1422 <sup>b</sup> ; 1867 <sup>a</sup> ; 1868 <sup>a</sup>	קְדָמִיאל 1789 <sup>a</sup>
צָפוּי }	צָרָה 1141 <sup>b</sup> ; 1275 <sup>a</sup> ; 2506 <sup>b</sup> ;	קְדָמוּנִי see קְדָמוּנִי
צָפוֹן } 2155 <sup>a</sup> ; 3132 <sup>a</sup>	צָרָה } 2545 <sup>a</sup>	קְדָקָד 762 <sup>a</sup> ; 1348 <sup>a</sup> ; 2263 <sup>a</sup>
צָפוֹן }	צָרְפָת 3132 <sup>b</sup>	קְדָר 1798 <sup>a</sup>
צָפוּנִי 3146 <sup>b</sup>	צָרַר 64 <sup>b</sup> ; 944 <sup>b</sup> ; 2864 <sup>a</sup> ;	קְדָר 1790 <sup>a</sup>
צָפוּר } 1143 <sup>a</sup> ; 2838 <sup>b</sup> ; 3152 <sup>b</sup>	צָרַר } 3049 <sup>a</sup>	קְדָרוֹן 1798 <sup>a</sup>
צָפֹר }	צָרָת 3133 <sup>a</sup> ; 3147 <sup>b</sup>	קְדָרוֹת 485 <sup>a</sup>
צָפְתָה 764 <sup>a</sup>	צָרָת הַשָּׁמַיִם 3133 <sup>a</sup> ; 3147 <sup>b</sup>	קְדִישׁ 816 <sup>b</sup> ; 818 <sup>a</sup> ; 1323 <sup>a, b</sup> ;
צָפוֹן 3152 <sup>b</sup>	צָרְתָה 3132 <sup>b</sup> ; 3133 <sup>a</sup>	קְדִישׁ } 1408 <sup>b</sup> ; 2681 <sup>b</sup> ;
צָפִים 2127 <sup>a</sup> ; 3157 <sup>a</sup>	ק	קְדִישׁ } 2682 <sup>a</sup>
צָפִירָה 841 <sup>a</sup> ; 869 <sup>a</sup>	קָא } 1559 <sup>b</sup> ; 2297 <sup>a</sup>	קְדִישׁ 1790 <sup>b</sup>
צָפִן 1006 <sup>a</sup> ; 1389 <sup>a</sup> ; 2155 <sup>a</sup> ;	קִיא } 2297 <sup>a</sup> ; 2697 <sup>a</sup>	קְדִישׁ } 326 <sup>b</sup> ; 1403 <sup>b</sup> ; 1405 <sup>a, b</sup> ;
2711 <sup>b</sup>	קִיאָת 2297 <sup>a</sup> ; 2697 <sup>a</sup>	קְדִישׁ } 1596 <sup>b</sup> ; 2686 <sup>b</sup> ;
צָפוֹן see צָפוֹן	קָב 1788 <sup>a</sup>	קְדִישׁ } 2758 <sup>b</sup>
צָפְנָה } 938 <sup>a</sup> ; 3144 <sup>a</sup>	קָבָה 2013 <sup>a</sup>	קְדִישׁ } 703 <sup>a</sup> ; 1132 <sup>b</sup> ; 1788 <sup>b</sup> ;
צָפְנָה }	קָבָה 432 <sup>a</sup> ; 2013 <sup>a</sup>	קְדִישׁ } 1789 <sup>a</sup> ; 1971 <sup>b</sup> ;
צָפְנָת פְּעֻמָּה 2089 <sup>b</sup> ; 3132 <sup>a</sup>	קָבָה 89 <sup>b</sup> ; 2293 <sup>a</sup> ; 3149 <sup>b</sup>	קְדִישׁ } 2007 <sup>b</sup> ; 2821 <sup>b</sup>
צָפַע } 55 <sup>a</sup> ; 411 <sup>a</sup> ; 672 <sup>b</sup> ;	קָבָה } 287 <sup>b</sup> ; 2524 <sup>a</sup>	קְדִישׁ see קְדוּשׁ
צָפְעָנִי } 2737 <sup>b</sup> ; 2738 <sup>a</sup>	קָבָל 612 <sup>b</sup> ; 613 <sup>b</sup>	קְדִישׁ בְּרִינֵעַ 1788 <sup>b</sup>
צָפָה 612 <sup>a</sup> ; 2295 <sup>a</sup>	קָבַעַת 511 <sup>b</sup> ; 875 <sup>b</sup>	קְדִישָׁה 746 <sup>b</sup> ; 1339 <sup>b</sup> ; 2211 <sup>a</sup> ;
צָפְפָה 3085 <sup>b</sup>	קָבַץ 1177 <sup>b</sup> ; 1350 <sup>b</sup> ; 2415 <sup>b</sup>	קְדִישָׁה } 2682 <sup>a</sup> ; 2821 <sup>b</sup>
צָפַר 1143 <sup>a</sup> ; 1249 <sup>a</sup>	קָבָל } 1788 <sup>a</sup>	קְדָה 899 <sup>a</sup>
צָפַר 1143 <sup>a</sup>	קָבַר 532 <sup>a</sup>	קְהֵל 651 <sup>a</sup>
צָפַר see צָפֹר	קָבָרָה see קָבָרָה	קְהֵל } 132 <sup>b</sup> ; 653 <sup>b</sup> ; 700 <sup>b</sup> ;
צָפְרָדַע 1147 <sup>a</sup> ; 2404 <sup>a</sup>		קְהֵל } 701 <sup>a</sup>
צָפְרָה 2774 <sup>a</sup> ; 3152 <sup>b</sup>		קְהֵלָת 894 <sup>b</sup> ; 1816 <sup>b</sup> ; 2433 <sup>a</sup> ;
צָפְרָן 2111 <sup>a</sup>		2649 <sup>b</sup>
		קְהֵלָתָה 1791 <sup>a</sup>
		קְהֵת 1816 <sup>a</sup>
		קְהֵתִי 1816 <sup>a</sup>

קר } 2016<sup>a</sup>; 2044<sup>b</sup>; 3080<sup>a</sup>  
 קר  
 קובע 253<sup>b</sup>  
 קנה 2263<sup>b</sup>  
 קנה 2016<sup>a</sup>  
 קיט 1306<sup>b</sup>; 2870<sup>a</sup>  
 קול { 1053<sup>a</sup>; 1094<sup>a</sup>; 1892<sup>b</sup>;  
 2154<sup>b</sup>; 2293<sup>b</sup>;  
 קל { 2309<sup>a</sup>; 2476<sup>a</sup>;  
 2977<sup>a</sup>  
 קוליה 1816<sup>b</sup>  
 קים 944<sup>b</sup>; 2461<sup>a</sup>; 2527<sup>a</sup>  
 קומה 1369<sup>a</sup>; 2850<sup>a</sup>  
 קינ 728<sup>b</sup>; 2117<sup>a</sup>  
 קיץ 1810<sup>b</sup>; 1816<sup>a</sup>  
 קוס } 160<sup>b</sup>  
 קס  
 קיץ 6<sup>b</sup>; 2870<sup>a</sup>  
 קיץ } 33<sup>b</sup>; 734<sup>a</sup>; 943<sup>a</sup>;  
 קץ } 1321<sup>b</sup>; 2974<sup>b</sup>  
 קנצה 1907<sup>a, b</sup>  
 קיר 849<sup>a</sup>; 2840<sup>b</sup>  
 קירה } 417<sup>a</sup>; 1167<sup>b</sup>; 1437<sup>a</sup>  
 קרה  
 קישיה 1818<sup>a</sup>  
 קטב 2403<sup>a</sup>  
 קטורה 1446<sup>b</sup>; 2639<sup>a, b</sup>  
 קטורה 1793<sup>b</sup>  
 קטן 1111<sup>b</sup>  
 קיץ } 1321<sup>b</sup>  
 קיץ  
 קטה 760<sup>b</sup>  
 קטר 1446<sup>b</sup>; 2321<sup>b</sup>  
 קטר 1446<sup>b</sup>  
 קטרון 1814<sup>a</sup>  
 קטרת 111<sup>b</sup>; 2321<sup>b</sup>; 2639<sup>a, b</sup>;  
 2840<sup>a</sup>  
 קשת 1790<sup>a</sup>  
 קנה 1559<sup>b</sup>  
 קיט 2710<sup>b</sup>; 2870<sup>a</sup>  
 קיטור } 3046<sup>a</sup>  
 קיטור  
 קימוש see קמוש  
 קינ 538<sup>b</sup>; 1789<sup>b</sup>  
 קינה 1798<sup>b</sup>; 1824<sup>a</sup>; 1836<sup>a</sup>;  
 2413<sup>a</sup>; 3145<sup>b</sup>  
 קיני } 1799<sup>a</sup>  
 קיני

קינן 1791<sup>b</sup>  
 קיץ 2710<sup>b</sup>; 2870<sup>b</sup>; 2982<sup>b</sup>  
 קיקרון 1286<sup>b</sup>  
 קיר } 171<sup>b</sup>; 302<sup>a</sup>; 1167<sup>a</sup>;  
 קר } 1810<sup>b</sup>; 1971<sup>b</sup>;  
 קר } 1980<sup>b</sup>; 2007<sup>a</sup>;  
 קירה } 2720<sup>b</sup>; 3001<sup>a</sup>  
 קיר קרש } 302<sup>a</sup>; 1811<sup>a</sup>  
 קיר קרש  
 קירוס } 1793<sup>b</sup>  
 קירוס  
 קיש 1813<sup>a</sup>  
 קישון 1813<sup>a</sup>  
 קישי 1813<sup>a</sup>  
 קל 1789<sup>b</sup>  
 קל see קול  
 קלה 411<sup>a</sup>; 1006<sup>a</sup>; 2247<sup>b</sup>  
 קלון 700<sup>b</sup>; 2748<sup>a</sup>  
 קלחת 541<sup>a</sup>  
 קלי 1789<sup>b</sup>  
 קלנה 1791<sup>b</sup>  
 קליטא 1791<sup>b</sup>  
 קלל 1006<sup>a</sup>; 1349<sup>a</sup>; 1892<sup>b</sup>  
 קללה 767<sup>a</sup>  
 קלס 2072<sup>b</sup>  
 קלסה 2072<sup>b</sup>  
 קלע 581<sup>b</sup>  
 קלע 1335<sup>b</sup>; 2889<sup>a</sup>  
 קלע 252<sup>a</sup>  
 קלשון 1136<sup>a</sup>  
 קמה 2847<sup>b</sup>  
 קמראל 1791<sup>b</sup>  
 קמון 1789<sup>b</sup>  
 קמוש } 2140<sup>a</sup>; 2974<sup>b</sup>  
 קימוש  
 קמח 1111<sup>a</sup>; 1122<sup>a</sup>  
 קמט 3114<sup>a</sup>  
 קמץ 1334<sup>b</sup>  
 קמשון 2140<sup>a</sup>  
 קן 494<sup>a</sup>; 2138<sup>b</sup>  
 קנא 955<sup>a</sup>; 2797<sup>b</sup>  
 קנא 533<sup>a</sup>  
 קנא 1264<sup>b</sup>; 1267<sup>b</sup>  
 קנאה 955<sup>a</sup>; 1267<sup>b</sup>; 1572<sup>b</sup>  
 קנה 328<sup>a</sup>; 533<sup>a</sup>; 538<sup>b</sup>;  
 583<sup>b</sup>; 1221<sup>a</sup>;  
 1789<sup>b</sup>; 2117<sup>a</sup>;  
 2422<sup>b</sup>; 2506<sup>a</sup>;  
 2872<sup>b</sup>

קנה 379<sup>b</sup>; 513<sup>b</sup>; 544<sup>a</sup>;  
 548<sup>b</sup>; 2016<sup>a</sup>;  
 2544<sup>a, b</sup>; 2545<sup>a</sup>;  
 2780<sup>b</sup>; 2847<sup>b</sup>;  
 3079<sup>a</sup>  
 קניז 1791<sup>b</sup>; 3032<sup>a</sup>  
 קניז 1791<sup>b</sup>  
 קנזן 1221<sup>a</sup>; 1279<sup>b</sup>; 2590<sup>b</sup>  
 קנמון 656<sup>a</sup>  
 קנת 1791<sup>b</sup>  
 קסם 1964<sup>a</sup>  
 קסם 862<sup>a</sup>; 1964<sup>b</sup>; 3097<sup>b</sup>  
 קסת 1322<sup>a</sup>; 1469<sup>b</sup>  
 קעילה 1791<sup>a</sup>  
 קעקע 1986<sup>a</sup>  
 קערה 595<sup>a</sup>; 854<sup>b</sup>; 2408<sup>a</sup>  
 קה see קיה  
 קפא 766<sup>b</sup>  
 קפד 2422<sup>a</sup>  
 קפור { 484<sup>a</sup>; 485<sup>a</sup>; 1367<sup>a</sup>;  
 קפד { 2421<sup>a</sup>; 2422<sup>a</sup>;  
 2697<sup>a</sup>  
 קפור 260<sup>a</sup>; 1367<sup>a</sup>; 2138<sup>b</sup>;  
 2422<sup>a</sup>; 2697<sup>a</sup>;  
 2736<sup>b</sup>; 2737<sup>a, b</sup>;  
 2738<sup>a</sup>  
 קפע 2422<sup>a</sup>  
 קץ 504<sup>a</sup>; 1467<sup>a</sup>  
 קץ see קיץ  
 קצב 510<sup>b</sup>  
 קצה 2716<sup>b</sup>  
 קצה { 503<sup>b</sup>; 522<sup>a</sup>; 523<sup>a</sup>;  
 קצה { 899<sup>a</sup>; 1147<sup>a</sup>;  
 1467<sup>a</sup>; 2780<sup>a</sup>  
 קצה 2513<sup>a</sup>  
 קצה 1117<sup>a</sup>; 1123<sup>a</sup>  
 קצין 569<sup>a</sup>; 1308<sup>b</sup>; 2454<sup>b</sup>;  
 2626<sup>a</sup>  
 קציעה 582<sup>a</sup>; 1797<sup>a</sup>  
 קציץ 940<sup>b</sup>; 1797<sup>a</sup>  
 קציר 513<sup>b</sup>; 1341<sup>b</sup>; 2982<sup>b</sup>  
 קצה 1121<sup>a</sup>; 1145<sup>b</sup>  
 קצה 510<sup>b</sup>; 1121<sup>a</sup>  
 קציץ 316<sup>b</sup>; 2415<sup>b</sup>  
 קצר 2093<sup>b</sup>; 2534<sup>a</sup>; 2780<sup>a</sup>  
 קר see קיר  
 קר 673<sup>b</sup>  
 קרא 459<sup>a</sup>; 593<sup>b</sup>; 764<sup>b</sup>;  
 1308<sup>b</sup>; 1336<sup>b</sup>;  
 2112<sup>a</sup>; 2433<sup>a</sup>;  
 2534<sup>a</sup>  
 קרא 1818<sup>a</sup>; 2254<sup>a</sup>

קרב	1334 <sup>a</sup> ; 2126 <sup>a</sup> ; 2639 <sup>b</sup>	קָשָׁה	655 <sup>b</sup> ; 1306 <sup>b</sup> ; 1337 <sup>b</sup> ; 1354 <sup>a</sup> ; 2854 <sup>a</sup>	רְבָה	333 <sup>a</sup> ; 334 <sup>b</sup> ; 1350 <sup>b</sup> ; 1907 <sup>b</sup>
קרב	746 <sup>a</sup> ; 1490 <sup>b</sup> ; 2510 <sup>a</sup> ; 2947 <sup>a</sup>	קָשָׁה	1338 <sup>b</sup>	רְבָה	2520 <sup>b</sup> ; 2522 <sup>a</sup>
קרב	see קָרֹב	קָשִׁיזֶן	1813 <sup>a</sup>	רְבוּ	2157 <sup>b</sup> ; 2159 <sup>a</sup>
קרבן	709 <sup>b</sup> ; 1059 <sup>a</sup> ; 1864 <sup>a</sup> ; 2177 <sup>b</sup> ; 2396 <sup>b</sup> ; 2639 <sup>a, b</sup> ; 2644 <sup>a</sup>	קָשִׁיטָה	1793 <sup>b</sup> ; 2076 <sup>a, b</sup> ; 2394 <sup>b</sup> ; 2395 <sup>a</sup>	רְבוּא	2781 <sup>a</sup>
קרהם	341 <sup>b</sup>	קָשָׁשׁוֹת	2701 <sup>a</sup>	רְבִיב	589 <sup>a</sup> ; 2129 <sup>b</sup>
קרה	133 <sup>b</sup> ; 210 <sup>a</sup> ; 417 <sup>a</sup>	קָשָׁר	474 <sup>b</sup> ; 699 <sup>a</sup> ; 1968 <sup>a</sup> ; 3007 <sup>b</sup>	רְבִית	2522 <sup>a</sup>
קרה	see קוֹרָה	קָשָׁר	699 <sup>a</sup> ; 3007 <sup>b</sup>	רְבִלָה	2590 <sup>a</sup>
קרוֹב	99 <sup>b</sup> ; 1334 <sup>a</sup> ; 1810 <sup>a</sup> ;	קָשָׁת	252 <sup>a</sup> ; 2527 <sup>a</sup>	רְבִמָּג	1962 <sup>b</sup> ; 2522 <sup>a</sup>
קֹרֵב	2126 <sup>a</sup> ; 2132 <sup>b</sup>	ר		רְבִסְרִיס	2522 <sup>b</sup>
קרח	764 <sup>b</sup> ; 1147 <sup>a</sup> ; 1446 <sup>b</sup> ;	רָאָה	65 <sup>a</sup> ; 208 <sup>a</sup> ; 477 <sup>b</sup> ; 851 <sup>a</sup> ; 997 <sup>b</sup> ; 1068 <sup>b</sup> ; 1234 <sup>b</sup> ; 1267 <sup>b</sup> ; 2027 <sup>b</sup> ; 2411 <sup>a</sup> ; 2581 <sup>a</sup> ; 2921 <sup>b</sup>	רְבַע	1183 <sup>b</sup>
קִרְחָה	2860 <sup>a, b</sup>	רָאָה	1308 <sup>a</sup> ; 1341 <sup>a</sup> ; 2459 <sup>b</sup> ; 2581 <sup>a</sup> ; 2713 <sup>a</sup>	רְבַע	1142 <sup>b</sup>
קרח	1816 <sup>b</sup> ; 1817 <sup>b</sup>	רְאוּבֵן	2572 <sup>a</sup>	רְבַע	2079 <sup>a</sup> ; 2534 <sup>b</sup>
קרח	1790 <sup>a</sup>	רְאוּבֵנִי	2573 <sup>b</sup>	רְבִץ	723 <sup>b</sup>
קרהה	380 <sup>b</sup>	רְאוּמָה	2573 <sup>b</sup>	רְבָקָה	2534 <sup>b</sup>
קרחא	1817 <sup>b</sup>	רְאוּ	1179 <sup>b</sup>	רְבָשָׁקָה	2522 <sup>b</sup>
קרחי	705 <sup>a</sup>	רְאוּ	2534 <sup>a</sup>	רְבָב	669 <sup>b</sup>
קריאה	2433 <sup>a</sup>	רְאִים	144 <sup>a</sup> ; 165 <sup>b</sup> ; 584 <sup>a</sup> ; 2218 <sup>a</sup> ; 2511 <sup>b</sup> ; 2589 <sup>a</sup> ; 3037 <sup>b</sup> ; 3084 <sup>b</sup> ; 3156 <sup>a</sup>	רְבַז	1145 <sup>b</sup>
קריה	662 <sup>a</sup> ; 665 <sup>b</sup> ; 1811 <sup>a</sup>	רְאִים		רְבַז	2154 <sup>b</sup>
קריה	1765 <sup>b</sup> ; 1793 <sup>a</sup>	רְאִים		רְבַל	376 <sup>b</sup> ; 1248 <sup>a</sup> ; 2710 <sup>a</sup> ; 2814 <sup>b</sup>
קרנת הצהר	1811 <sup>a</sup>	רְאִים		רְבַל	523 <sup>b</sup> ; 1121 <sup>b</sup> ; 1125 <sup>a</sup> ; 1344 <sup>a</sup> ; 1865 <sup>a</sup> ; 2257 <sup>b</sup>
קרנתים	1811 <sup>a</sup>	רְאִים		רְבָלִים	2597 <sup>a</sup>
קרנת וערים	1811 <sup>a</sup>	רְאִים		רְבָם	2910 <sup>b</sup>
קרנת ערים	1811 <sup>a</sup>	רְאִים		רְבָם	2546 <sup>b</sup>
קרנת-סנה	813 <sup>b</sup> ; 1812 <sup>b</sup>	רְאִים		רְבָן	2094 <sup>b</sup>
קרנת-ספר	2773 <sup>b</sup>	רְאִים		רְבַע	860 <sup>a</sup>
קרן	1131 <sup>b</sup> ; 1322 <sup>b</sup> ; 1392 <sup>b</sup> ; 1422 <sup>a</sup> ; 1756 <sup>a</sup> ; 2095 <sup>a</sup> ; 2097 <sup>a</sup>	רְאִים		רְבַע	2076 <sup>a</sup>
קרן הפסח	1793 <sup>a</sup>	רְאִים		רְבַשׁ	491 <sup>a</sup>
קרס	665 <sup>b</sup>	רְאִים		רְבָשָׁה	2626 <sup>a</sup>
קרס	see קִירֶס	רְאִים		רְבִי	2524 <sup>a</sup>
קרסל	1125 <sup>a</sup>	רְאִים		רְבִיד	3047 <sup>a</sup>
קרע	670 <sup>a</sup>	רְאִים		רְבִם	282 <sup>b</sup> ; 2817 <sup>b</sup>
קרע	2524 <sup>b</sup>	רְאִים		רְבִם	1121 <sup>b</sup>
קרקע	510 <sup>b</sup> ; 1435 <sup>a</sup> ; 1790 <sup>a</sup>	רְאִים		רְבִב	2871 <sup>b</sup>
קרקר	1790 <sup>a</sup>	רְאִים		רְבִב	2525 <sup>b</sup>
קרש	434 <sup>a</sup> ; 491 <sup>a</sup>	רְאִים		רְבִט	1167 <sup>b</sup> ; 1320 <sup>b</sup> ; 1437 <sup>a</sup>
קרחה	1790 <sup>a</sup>	רְאִים		רְבִיט	1136 <sup>a</sup>
קרחה	1790 <sup>a</sup>	רְב	17 <sup>b</sup> ; 569 <sup>a</sup> ; 1294 <sup>a</sup> ; 1307 <sup>b</sup> ; 1569 <sup>b</sup> ; 1981 <sup>b</sup> ; 2522 <sup>a</sup> ; 2775 <sup>a</sup>	רִיב	see רִיב
קש	2866 <sup>b</sup> ; 2867 <sup>b</sup>	רְב		רְבָה	2545 <sup>b</sup>
קשא	765 <sup>b</sup> ; 1122 <sup>a</sup>	רְבִב	1981 <sup>b</sup>	רְבָה	880 <sup>b</sup>
קשב	328 <sup>b</sup>	רְבִבָה	2159 <sup>a</sup>	רְבָה	2597 <sup>a</sup>
קשנה	1117 <sup>b</sup> ; 2425 <sup>b</sup>	רְבִד	2909 <sup>a</sup>	רְבָה	952 <sup>b</sup> ; 1306 <sup>b</sup>
קשה	1337 <sup>b</sup> ; 1338 <sup>a</sup>				

רִיחַ	68 <sup>b</sup> ; 88 <sup>b</sup> ; 486 <sup>a</sup> ; 518 <sup>a</sup> ; 708 <sup>a</sup> ; 724 <sup>b</sup> ; 973 <sup>a</sup> ; 1074 <sup>a</sup> ; 1253 <sup>b</sup> ; 1350 <sup>b</sup> ; 1351 <sup>a</sup> ; 1406 <sup>b</sup> ; 1474 <sup>a</sup> ; 1888 <sup>a</sup> ; 1918 <sup>a</sup> ; 2056 <sup>a</sup> ; 2496 <sup>b</sup> ; 2497 <sup>a</sup> ; 2515 <sup>a, b</sup> ; 2562 <sup>b</sup> ; 2563 <sup>a</sup> ; 2818 <sup>a</sup> ; 2837 <sup>a</sup> ; 2838 <sup>a</sup> ; 2841 <sup>a</sup> ; 3085 <sup>b</sup>	רַחֵם	492 <sup>a</sup> ; 511 <sup>a</sup> ; 695 <sup>a</sup> ; 2402 <sup>a</sup> ; 2525 <sup>b</sup> ; 2947 <sup>a</sup>	רָקַשׁ	419 <sup>a</sup> ; 547 <sup>b</sup> ; 1423 <sup>b</sup> ; 2093 <sup>b</sup> ; 2875 <sup>b</sup>
רִיחַ	518 <sup>a</sup> ; 709 <sup>a</sup> ; 1049 <sup>b</sup> ; 1232 <sup>b</sup> ; 1369 <sup>a</sup> ; 2527 <sup>b</sup>	רַחֵם	492 <sup>a</sup> ; 511 <sup>a</sup> ; 2453 <sup>a</sup>	רָקַשׁ	see רָקַשׁ
רִימָה	2627 <sup>a</sup>	רַחֵם	1228 <sup>a</sup>	רָם	see רָאָם
רִמְמַתֵּי עֶזְרָא	2597 <sup>b</sup>	רַחֵם	1228 <sup>a</sup>	רָם	258 <sup>b</sup> ; 1569 <sup>b</sup> ; 2438 <sup>b</sup> ; 2527 <sup>b</sup>
רִמְמַתֵּי		רַחֲמָה	2402 <sup>a</sup>	רָם	see רָם
רִיעַ	764 <sup>b</sup>	רַחֲמָה	412 <sup>b</sup> ; 415 <sup>a</sup> ; 3072 <sup>b</sup>	רָמָה	454 <sup>b</sup> ; 1390 <sup>a</sup> ; 2527 <sup>b</sup>
רִיעַ	1307 <sup>b</sup> ; 2379 <sup>b</sup> ; 2423 <sup>a</sup>	רַחֲמָה	3073 <sup>b</sup>	רָמָה	3109 <sup>a</sup>
רִיעַ	2420 <sup>a</sup> ; 2426 <sup>b</sup>	רַחֲמָה	see רַחֲמָה	רָמוֹן	2417 <sup>b</sup> ; 2557 <sup>b</sup> ; 2593 <sup>b</sup> ; 2594 <sup>a</sup>
רִיעַ	see רִאֵשׁ	רַחֲמָה	494 <sup>b</sup> ; 1467 <sup>a</sup>	רָמוֹן	
רִיעַ	2627 <sup>a</sup>	רַחֲמָה	2780 <sup>b</sup>	רָמוֹן	2557 <sup>b</sup>
רִיעַ	404 <sup>b</sup> ; 2105 <sup>a</sup>	רַחֲמָה	1145 <sup>b</sup>	רָמוֹן	1591 <sup>a</sup> ; 2528 <sup>b</sup> ; 2529 <sup>a</sup>
רִיעַ		רַחֲמָה	606 <sup>a</sup> ; 706 <sup>a</sup> ; 2522 <sup>b</sup>	רָמוֹן	
רִיעַ	1097 <sup>b</sup>	רַחֲמָה	1569 <sup>b</sup> ; 1593 <sup>a</sup> ; 2408 <sup>b</sup> ; 2535 <sup>a</sup>	רָמָה	252 <sup>a</sup>
רִיעַ	2588 <sup>b</sup>	רַחֲמָה	2590 <sup>a</sup>	רָמָה	2529 <sup>a</sup>
רִיעַ	2454 <sup>a</sup>	רַחֲמָה	2700 <sup>b</sup> ; 2701 <sup>b</sup> ; 2818 <sup>a</sup>	רָמָה	1309 <sup>a</sup>
רִיעַ	2399 <sup>b</sup>	רַחֲמָה	see רָאָם	רָמָה	547 <sup>b</sup> ; 548 <sup>a</sup> ; 1424 <sup>a</sup> ; 1985 <sup>a</sup>
רִיעַ	3088 <sup>b</sup>	רַחֲמָה	see רַעַ	רָמָה	2557 <sup>a</sup>
רִיעַ	2454 <sup>a</sup> ; 2626 <sup>a</sup> ; 3049 <sup>b</sup>	רַחֲמָה	1307 <sup>a</sup>	רָמָם	1049 <sup>b</sup> ; 2594 <sup>a</sup> ; 3109 <sup>a</sup>
רִיעַ	517 <sup>a</sup>	רַחֲמָה	851 <sup>a</sup> ; 2594 <sup>b</sup>	רָמוֹן	see רָמוֹן
רִיעַ	523 <sup>a</sup> ; 2550 <sup>b</sup>	רַחֲמָה	941 <sup>b</sup>	רָמוֹן פָּרָץ	2594 <sup>a</sup>
רִיעַ		רַחֲמָה	941 <sup>b</sup> ; 1106 <sup>a</sup> ; 2523 <sup>a</sup>	רָמַשׁ	743 <sup>b</sup>
רִיעַ	517 <sup>a</sup> ; 523 <sup>a</sup>	רַחֲמָה	941 <sup>b</sup>	רָמַשׁ	743 <sup>b</sup>
רִיעַ	1881 <sup>b</sup> ; 2144 <sup>a</sup> ; 2525 <sup>a</sup>	רַחֲמָה	676 <sup>a</sup> ; 2846 <sup>a</sup>	רָמַת	2557 <sup>a</sup>
רִיעַ	2552 <sup>a, b</sup>	רַחֲמָה	1348 <sup>a</sup>	רָמַת	2529 <sup>a</sup>
רִיעַ		רַחֲמָה	487 <sup>b</sup> ; 1861 <sup>b</sup> ; 2947 <sup>a</sup>	רָמַת	
רִיעַ	2550 <sup>b</sup>	רַחֲמָה	2947 <sup>a</sup>	רָמַת	2529 <sup>a</sup>
רִיעַ	2551 <sup>a</sup>	רַחֲמָה	595 <sup>a</sup>	רָמַת	2529 <sup>a</sup>
רִיעַ	see רַחֲבָה	רַחֲמָה	2535 <sup>b</sup> ; 2536 <sup>a</sup>	רָמַת	2528 <sup>a</sup>
רִיעַ	2052 <sup>a</sup>	רַחֲמָה	604 <sup>a</sup>	רָמַת	2528 <sup>a</sup>
רִיעַ	see רַחֲבָה	רַחֲמָה	2947 <sup>a</sup>	רָמַת	2528 <sup>a</sup>
רִיעַ	2552 <sup>b</sup> ; 2553 <sup>a</sup>	רַחֲמָה	595 <sup>a</sup>	רָמַת	2529 <sup>a</sup>
רִיעַ	1097 <sup>b</sup>	רַחֲמָה	2535 <sup>b</sup>	רָמַת	2529 <sup>a</sup>
רִיעַ		רַחֲמָה	2535 <sup>b</sup> ; 2536 <sup>a</sup>	רָמַת	2528 <sup>a</sup>
רִיעַ	1167 <sup>b</sup>	רַחֲמָה	604 <sup>a</sup>	רָמַת	2528 <sup>a</sup>
רִיעַ	1049 <sup>a</sup> ; 2523 <sup>b</sup> ; 2524 <sup>a</sup>	רַחֲמָה	1202 <sup>a</sup> ; 1279 <sup>a</sup> ; 2590 <sup>b</sup> ; 2868 <sup>a</sup>	רָמַת	2529 <sup>a</sup>
רִיעַ	18 <sup>a</sup> ; 695 <sup>a</sup> ; 2035 <sup>b</sup> ; 2402 <sup>a</sup>	רַחֲמָה	1086 <sup>b</sup> ; 2075 <sup>b</sup>	רָמַת	2529 <sup>a</sup>
		רַחֲמָה	687 <sup>b</sup> ; 2427 <sup>b</sup> ; 3002 <sup>a</sup>	רָמַת	64 <sup>b</sup> ; 540 <sup>b</sup> ; 748 <sup>a</sup> ; 1041 <sup>b</sup> ; 1042 <sup>b</sup> ; 1043 <sup>a, b</sup> ; 1354 <sup>a</sup> ; 1442 <sup>a</sup> ; 2122 <sup>b</sup> ; 2155 <sup>a</sup> ; 2798 <sup>b</sup> ; 3083 <sup>b</sup> ; see also
		רַחֲמָה	2523 <sup>b</sup>	רָמַת	רָמַת
		רַחֲמָה	2035 <sup>a</sup> ; 3002 <sup>a</sup> ; 3004 <sup>b</sup> ; 3005 <sup>a</sup>	רָמַת	רָמַת
		רַחֲמָה	548 <sup>a</sup> ; 1221 <sup>a</sup>	רָמַת	רָמַת

רע	1022 <sup>a</sup> ; 1106 <sup>a</sup> ; 1934 <sup>a</sup> ;	רפירים	2560 <sup>b</sup>	רתם	525 <sup>a</sup> ; 672 <sup>a</sup> ; 1781 <sup>a</sup>
ריע	2132 <sup>b</sup> ; 2553 <sup>a</sup>	רפיה	2559 <sup>b</sup>	רתם	
רע	2122 <sup>b</sup> ; 3084 <sup>a</sup>	רפסרה	2774 <sup>b</sup>	רהמיה	2595 <sup>a</sup>
רעב	1097 <sup>b</sup>	רפש	1141 <sup>b</sup>	ש and ש	
רעב	1097 <sup>a</sup> ; 1440 <sup>a</sup>	רפת	2847 <sup>b</sup>	שאב	873 <sup>b</sup>
רעבון	1097 <sup>a</sup>	רץ	2076 <sup>b</sup> ; 2395 <sup>a</sup>	שאל	27 <sup>a</sup> ; 974 <sup>b</sup> ; 992 <sup>b</sup> ; 1370 <sup>b</sup> ; 1905 <sup>b</sup> ; 2401 <sup>b</sup> ; 2761 <sup>a</sup>
רעה	1102 <sup>a</sup>	רצא	966 <sup>b</sup>	שאל	
רעה	523 <sup>a</sup> ; 584 <sup>a</sup> ; 631 <sup>b</sup> ; 1375 <sup>b</sup> ; 2258 <sup>a</sup> ; 2763 <sup>a</sup> ; 2825 <sup>a</sup> ; 2921 <sup>b</sup> ; see also רע	רצה	27 <sup>b</sup> ; 321 <sup>a</sup> ; 820 <sup>a</sup> ; 2094 <sup>a</sup> ; 2536 <sup>b</sup> ; 2987 <sup>a</sup>	שאולי	2697 <sup>b</sup>
רעה	1146 <sup>a</sup>	רצון	27 <sup>b</sup> ; 820 <sup>b</sup> ; 1102 <sup>a</sup> ; 1292 <sup>a</sup> ; 2408 <sup>b</sup> ; 2716 <sup>b</sup> ; 3085 <sup>a</sup>	שאון	1423 <sup>a</sup> ; 2154 <sup>a</sup>
רעה	1106 <sup>a</sup> ; 2825 <sup>a</sup>	רצו	2716 <sup>b</sup> ; 3085 <sup>a</sup>	שאט	833 <sup>b</sup>
רעי	2572 <sup>a</sup>	רצח	288 <sup>b</sup> ; 746 <sup>b</sup> ; 1418 <sup>a</sup> ; 1983 <sup>b</sup>	שאל	282 <sup>b</sup> ; 704 <sup>b</sup> ; 1305 <sup>a</sup> ; 1472 <sup>b</sup> ; 1865 <sup>b</sup> ; 2358 <sup>a</sup> ; 2761 <sup>b</sup> ; 3096 <sup>b</sup>
רעיאל	2525 <sup>a</sup> ; 2573 <sup>b</sup>	רצוא	2595 <sup>a</sup>	שאל	
רעית	2627 <sup>a</sup>	רצין	2588 <sup>a</sup>	שאל	see שאל
רעי	2553 <sup>a</sup>	רצה	2076 <sup>b</sup>	שאלא	1865 <sup>b</sup>
רעי	2763 <sup>a</sup>	רצה	671 <sup>b</sup> ; 2588 <sup>a</sup>	שאלה	2358 <sup>a</sup>
רעיה	1106 <sup>a</sup>	רצה	671 <sup>b</sup> ; 1984 <sup>b</sup> ; 2292 <sup>b</sup> ; 2595 <sup>a</sup>	שאלתיאל	
רעיון	673 <sup>a</sup> ; 896 <sup>b</sup>	רצין	523 <sup>a</sup> ; 526 <sup>b</sup>	שאן	888 <sup>b</sup>
רעלה	2093 <sup>b</sup>	רק	1438 <sup>b</sup> ; 1439 <sup>a</sup>	שאר	1862 <sup>a</sup> ; 2237 <sup>a</sup>
רעליה	2445 <sup>a</sup>	רק	2846 <sup>a</sup>	שאר	2557 <sup>b</sup>
רעם	709 <sup>a</sup> ; 1145 <sup>b</sup>	רקב	2624 <sup>a</sup>	שאר	492 <sup>a</sup> ; 1118 <sup>b</sup> ; 1810 <sup>a</sup> ; 2122 <sup>b</sup> ; 2837 <sup>a</sup>
רעם	2977 <sup>a</sup>	רקב	2624 <sup>a</sup>	שארה	1118 <sup>b</sup> ; 1810 <sup>a</sup>
רעמיה		רקב	2624 <sup>a</sup>	שארה	2758 <sup>a</sup> ; 3043 <sup>a</sup>
רעמיה	2520 <sup>a</sup>	רקבון	2624 <sup>a</sup>	שאר לשוב	2752 <sup>b</sup>
רעמא		רקב	2942 <sup>b</sup>	שאריה	2557 <sup>a, b</sup>
רעמיה	2520 <sup>a</sup> ; 2545 <sup>a</sup>	רקב	2527 <sup>b</sup>	שאה	849 <sup>a</sup> ; 1050 <sup>a</sup> ; 1867 <sup>a</sup> ; 2594 <sup>b</sup>
רעמס	2520 <sup>a</sup>	רקח	695 <sup>b</sup> ; 2321 <sup>b</sup>	שא	2629 <sup>a</sup> ; 2752 <sup>b</sup>
רעמס		רקח	2840 <sup>a</sup> ; 3086 <sup>a</sup>	שא	2629 <sup>a</sup>
רען	675 <sup>b</sup> ; 1145 <sup>b</sup>	רקח	695 <sup>b</sup> ; 699 <sup>a</sup>	שבה	569 <sup>b</sup> ; 1693 <sup>a</sup> ; 2752 <sup>b</sup>
רעע	517 <sup>b</sup> ; 1042 <sup>b</sup> ; 1442 <sup>a</sup>	רקחה	699 <sup>b</sup>	שוב	2856 <sup>b</sup> ; 2857 <sup>a</sup>
רעש	700 <sup>b</sup> ; 888 <sup>a, b</sup>	רקיע	315 <sup>a, b</sup> ; 3106 <sup>b</sup>	שובאל	2754 <sup>b</sup> ; 2781 <sup>a</sup>
רפא	815 <sup>a</sup> ; 974 <sup>b</sup> ; 1224 <sup>b</sup> ; 1349 <sup>a</sup> ; 2393 <sup>b</sup> ; 2532 <sup>b</sup> ; 2533 <sup>b</sup> ; 2558 <sup>a</sup> ; 2562 <sup>b</sup> ; 3083 <sup>b</sup> ; see also רפה, <i>infra</i>	רקיק	516 <sup>a</sup>	שובע	
רפה		רקם	767 <sup>a</sup>	שבועה	288 <sup>b</sup> ; 2172 <sup>b</sup>
רפאה		1349 <sup>a</sup> ; 2026 <sup>a</sup>	רקם	2527 <sup>b</sup> ; 2553 <sup>a</sup>	שבוח
רפאות	1350 <sup>a</sup>	רקמה	523 <sup>a</sup> ; 674 <sup>b</sup> ; 709 <sup>a</sup> ; 940 <sup>a</sup> ; 2534 <sup>b</sup>	שבית	
רפאל	2532 <sup>b</sup> ; 2559 <sup>b</sup>	רשם	2156 <sup>b</sup>	שבח	2429 <sup>a</sup>
רפה	766 <sup>b</sup> ; 1086 <sup>a</sup> ; 1447 <sup>b</sup> ; 2533 <sup>a</sup> ; 2559 <sup>b</sup> ; 2560 <sup>a</sup> ; see also רפא	רשע	698 <sup>a</sup>		
רפה	2560 <sup>a</sup>	רשע	3084 <sup>a</sup>		
רפה	see ריפה	רשע	3037 <sup>b</sup>		
רפה	2559 <sup>b</sup>	רשעה	1101 <sup>b</sup> ; 3083 <sup>b</sup> ; 3084 <sup>a, b</sup>		
רפירה	510 <sup>b</sup>	רשה	494 <sup>b</sup> ; 671 <sup>b</sup> ; 2561 <sup>b</sup>		
		רשת	1293 <sup>b</sup>		
		רתיק	589 <sup>a</sup>		
		רתח	494 <sup>a, b</sup>		

שָׁבַט	3010 <sup>a</sup>	שָׁבַט	2745 <sup>b</sup>	שָׂדֵה	see שָׂדֵה
שָׁבַט	722 <sup>b</sup> ; 1185 <sup>b</sup> ; 1801 <sup>a</sup> ; 2596 <sup>b</sup> ; 2701 <sup>b</sup> ; 2702 <sup>a</sup> ; 2847 <sup>b</sup> ; 3010 <sup>a</sup>	שָׂנָא	2746 <sup>b</sup>	שָׂנְהָה	340 <sup>a</sup> ; 694 <sup>b</sup> ; 724 <sup>a</sup>
שָׁבַט	541 <sup>b</sup> ; 2753 <sup>b</sup>	שָׂנַב	1049 <sup>b</sup>	שָׂנְהָה	2751 <sup>b</sup>
שָׁבִי	569 <sup>b</sup> ; 1052 <sup>b</sup>	שָׂנְהָה	970 <sup>b</sup> ; 1448 <sup>a</sup> ; 2645 <sup>a</sup>	שָׂנְהָה קְרִיבִים	2751 <sup>b</sup>
שָׁבִי	2779 <sup>a</sup>	שָׂנְהָה	970 <sup>b</sup>	שָׂנְהָה	2781 <sup>a</sup>
שָׁבִי	2779 <sup>a</sup>	שָׂגִיב	2713 <sup>a</sup>	שָׂנְהָה	2781 <sup>a</sup>
שָׁבִיב	1117 <sup>b</sup>	שָׂגִיבִין	2488 <sup>a, b</sup> ; 2767 <sup>b</sup> ;	שָׂנְהָה	2781 <sup>b</sup>
שָׁבִיב	1117 <sup>b</sup>	שָׂנְהָה	2910 <sup>b</sup>	שָׂנְהָה	2781 <sup>b</sup>
שָׂנְהָה	569 <sup>b</sup>	שָׂנַל	2513 <sup>b</sup>	שָׂנְהָה	2774 <sup>b</sup>
שָׂנְהָה	2745 <sup>b</sup>	שָׂנַל	2513 <sup>b</sup>	שָׂנְהָה	2704 <sup>a</sup>
שָׂנְהָה		שָׂנַע	1941 <sup>b</sup> ; 1960 <sup>b</sup>	שָׂנְהָה	1106 <sup>b</sup>
שָׂנְהָה	see שָׂנְהָה	שָׂנַה	517 <sup>b</sup> ; 2237 <sup>b</sup> ; 2923 <sup>b</sup>	שָׂנְהָה	513 <sup>b</sup>
שָׂנְהָה	see שָׂנְהָה	שָׂנַה		שָׂנְהָה	
שָׂנְהָה	see שָׂנְהָה	שָׂנַה	530 <sup>b</sup> ; 690 <sup>b</sup>	שָׂנְהָה	2868 <sup>b</sup>
שָׂנְהָה	599 <sup>a</sup> ; 2140 <sup>a</sup>	שָׂנַה	1341 <sup>a</sup>	שָׂנְהָה	
שָׂנַל	1865 <sup>a</sup>	שָׂנַה	1266 <sup>b</sup> ; 2846 <sup>a</sup>	שָׂנְהָה	577 <sup>b</sup> ; 688 <sup>a</sup> ; 728 <sup>b</sup> ; 1232 <sup>b</sup> ; 1350 <sup>b</sup> ; 1462 <sup>b</sup> ; 1859 <sup>a</sup> ; 1968 <sup>a</sup> ; 2200 <sup>b</sup> ; 2550 <sup>b</sup> ; 2756 <sup>b</sup> ; 2911 <sup>a</sup>
שָׂנַל	594 <sup>a</sup> ; 1120 <sup>a</sup> ; 2767 <sup>b</sup>	שָׂנַה	724 <sup>a</sup> ; 1286 <sup>b</sup> ; 1307 <sup>a</sup> ; 1826 <sup>b</sup> ; 3084 <sup>a</sup> ; 3157 <sup>a</sup>	שָׂנְהָה	
שָׂנַל		שָׂנַה	2101 <sup>b</sup>	שָׂנְהָה	2779 <sup>b</sup>
שָׂנַל	2819 <sup>a</sup>	שָׂנַה	100 <sup>a</sup> ; 145 <sup>b</sup> ; 1129 <sup>b</sup> ; 1250 <sup>a</sup> ; 1251 <sup>a</sup> ; 1254 <sup>a</sup> ; 1264 <sup>b</sup> ; 1267 <sup>a</sup> ; 2188 <sup>b</sup> ; 2393 <sup>a</sup> ; 3034 <sup>a</sup>	שָׂנְהָה	
שָׂנַל	513 <sup>b</sup>	שָׂנַה	2756 <sup>b</sup>	שָׂנְהָה	2681 <sup>b</sup>
שָׂנַל	2711 <sup>a</sup> ; 2767 <sup>b</sup>	שָׂנַה	2784 <sup>a</sup>	שָׂנְהָה	
שָׂנַל		שָׂנַה	486 <sup>a</sup>	שָׂנְהָה	764 <sup>b</sup>
שָׂנַל	2753 <sup>b</sup>	שָׂנַה	486 <sup>a</sup> ; 2051 <sup>b</sup>	שָׂנְהָה	
שָׂנַל		שָׂנַה	491 <sup>a</sup> ; 2530 <sup>a</sup>	שָׂנְהָה	2590 <sup>b</sup>
שָׂנַל	56 <sup>a</sup> ; 424 <sup>b</sup> ; 2864 <sup>a</sup>	שָׂנַה	583 <sup>b</sup> ; 1049 <sup>a</sup> ; 1240 <sup>b</sup> ; 1822 <sup>b</sup> ; 1823 <sup>a</sup> ; 3155 <sup>b</sup>	שָׂנְהָה	
שָׂנַל	2743 <sup>b</sup> ; 2753 <sup>b</sup> ; 2767 <sup>b</sup> ; 2982 <sup>a</sup> ; 3078 <sup>b</sup>	שָׂנַה	1574 <sup>a</sup>	שָׂנְהָה	2781 <sup>a</sup>
שָׂנַל	see שָׂנַל	שָׂנַה	709 <sup>a</sup> ; 2442 <sup>a</sup> ; 2779 <sup>b</sup> ; 2856 <sup>b</sup> ; 2857 <sup>a</sup> ; 2861 <sup>a</sup> ; 2862 <sup>a</sup>	שָׂנְהָה	
שָׂנַל	see שָׂנַל	שָׂנַה	303 <sup>b</sup> ; 744 <sup>b</sup>	שָׂנְהָה	869 <sup>a</sup> ; 2422 <sup>a</sup>
שָׂנַל	2744 <sup>a</sup>	שָׂנַה	3045 <sup>b</sup>	שָׂנְהָה	
שָׂנַל	940 <sup>a</sup> ; 3078 <sup>a</sup>	שָׂנַה	2751 <sup>b</sup> ; 2766 <sup>b</sup>	שָׂנְהָה	2779 <sup>a</sup>
שָׂנַל	136 <sup>a</sup>	שָׂנַה	340 <sup>b</sup> ; 522 <sup>b</sup> ; 706 <sup>a</sup> ; 1232 <sup>b</sup> ; 1248 <sup>a</sup> ; 1417 <sup>b</sup> ; 1693 <sup>a</sup> ; 2538 <sup>b</sup> ; 2558 <sup>a, b</sup>	שָׂנְהָה	
שָׂנַל	517 <sup>a</sup> ; 523 <sup>b</sup>	שָׂנַה	376 <sup>b</sup>	שָׂנְהָה	305 <sup>a</sup> ; 605 <sup>a</sup> ; 2095 <sup>a</sup> ; 2097 <sup>a</sup>
שָׂנַל		533 <sup>a</sup> ; 1442 <sup>a</sup> ; 1780 <sup>a</sup> ; 2512 <sup>b</sup>	שָׂנַה	2779 <sup>a</sup>	
שָׂנַל	514 <sup>b</sup> ; 523 <sup>b</sup> ; 737 <sup>b</sup> ; 1442 <sup>a</sup> ; 2512 <sup>b</sup> ; 2753 <sup>b</sup>	שָׂנַה	376 <sup>b</sup>	שָׂנְהָה	2782 <sup>a</sup>
שָׂנַל	2753 <sup>b</sup> ; 2912 <sup>b</sup>	שָׂנַה	2779 <sup>a</sup>	שָׂנְהָה	
שָׂנַל	586 <sup>a</sup> ; 587 <sup>a</sup> ; 1780 <sup>a</sup> ; 2629 <sup>b</sup>	שָׂנַה	2779 <sup>a</sup>	שָׂנְהָה	see שָׂנְהָה
שָׂנַל	1780 <sup>a</sup> ; 2318 <sup>b</sup> ; 2629 <sup>b</sup> ; 2634 <sup>b</sup> ; 2822 <sup>a</sup> ; 2982 <sup>a</sup>	שָׂנַה	2779 <sup>a</sup>	שָׂנְהָה	
שָׂנַל	2629 <sup>b</sup> ; 2634 <sup>b</sup> ; 2822 <sup>a</sup>	שָׂנַה	2779 <sup>a</sup>	שָׂנְהָה	see שָׂנְהָה





שְׁלוֹמִיית see שְׁלֹמִית  
 שְׁלוֹן 2747<sup>b</sup>  
 שְׁלוֹשׁ }  
 שְׁלֹשׁ } 2975<sup>b</sup>  
 שְׁלוֹשָׁה }  
 שְׁלֹשָׁה }  
 שְׁלוּ see שְׁלֹו  
 שְׁלַח 210<sup>a</sup>; 522<sup>b</sup>; 2721<sup>a</sup>  
 שְׁלַח 2721<sup>a</sup>; 2790<sup>a</sup>  
 שְׁלַח 2662<sup>a</sup>; 2758<sup>b</sup>; 2899<sup>b</sup>  
 שְׁלַח } 1609<sup>b</sup>; 2721<sup>a</sup>; 2758<sup>b</sup>;  
 שְׁלַח } 2791<sup>a</sup>  
 שְׁלַחִי 2768<sup>b</sup>  
 שְׁלַחִים 2768<sup>b</sup>  
 שְׁלַחֵן 2767<sup>b</sup>; 2898<sup>a, b</sup>  
 שְׁלַט 896<sup>b</sup>  
 שְׁלַט 2008<sup>a</sup>  
 שְׁלַט 2626<sup>b</sup>  
 שְׁלַטוֹן }  
 שְׁלַטָּן } 2626<sup>a</sup>  
 שְׁלַטָּן }  
 שְׁלֹו see שְׁלֹו  
 שְׁלִיט 569<sup>a</sup>; 1289<sup>b</sup>; 2626<sup>a</sup>  
 שְׁלִישׁ } 288<sup>b</sup>; 569<sup>a</sup>; 1136<sup>a</sup>;  
 שְׁלִישׁ } 1484<sup>a</sup>; 2016<sup>a</sup>;  
 שְׁלוֹשׁ } 2095<sup>a</sup>; 2097<sup>a</sup>;  
 שְׁלֹשׁ } 2790<sup>a</sup>  
 שְׁלִישִׁי 2973<sup>a</sup>  
 שְׁלָף 484<sup>b</sup>; 720<sup>b</sup>  
 שְׁלָכָה 2747<sup>a</sup>  
 שְׁלָל 2439<sup>a</sup>  
 שְׁלָם 943<sup>a</sup>; 2293<sup>a</sup>  
 שְׁלָם 1305<sup>b</sup>  
 שְׁלָם 551<sup>b</sup>; 2639<sup>a</sup>  
 שְׁלָם 2320<sup>b</sup>; 2663<sup>a</sup>; 2746<sup>b</sup>  
 שְׁלָם see שְׁלָו  
 שְׁלָם 2768<sup>b</sup>  
 שְׁלָם see שְׁלָו  
 שְׁלָמָא 2663<sup>b</sup>  
 שְׁלָמָה 876<sup>a</sup>; 2663<sup>b</sup>  
 שְׁלָמָה 2822<sup>a</sup>  
 שְׁלָמוֹן 2663<sup>b</sup>  
 שְׁלָמוֹת 2759<sup>a</sup>  
 שְׁלָמִי 2663<sup>b</sup>  
 שְׁלָמִי 2759<sup>a</sup>  
 שְׁלָמִי 2768<sup>b</sup>  
 שְׁלָמִיאל 2759<sup>a</sup>; 2761<sup>a</sup>

שְׁלִמְיָה }  
 שְׁלִמְיָהוּ } 2758<sup>b</sup>  
 שְׁלִמְיָה }  
 שְׁלִמְיָה } 2759<sup>a</sup>  
 שְׁלִמְיָה }  
 שְׁלִמְיָן 2747<sup>b</sup>  
 שְׁלִמְיָסָר 2747<sup>b</sup>  
 שְׁלִי see שְׁלֹו  
 שְׁלִי 2759<sup>a</sup>  
 שְׁלִשׁ 2759<sup>a</sup>  
 שְׁלִשׁ see שְׁלֹשׁ  
 שְׁלִשָׁה 2769<sup>a</sup>  
 שְׁלִשָׁה 2746<sup>b</sup>  
 שְׁלִשָׁה see שְׁלֹשׁ  
 שְׁלִשׁוֹם }  
 שְׁלִשׁוֹם } 1375<sup>b</sup>  
 שְׁלִיתִיאל see שְׁאֵלִיתִיאל  
 שְׁם 411<sup>a</sup>; 1094<sup>a</sup>; 1253<sup>b</sup>;  
 2112<sup>a</sup>; 2759<sup>a</sup>  
 שְׁמִיא 535<sup>b</sup>  
 שְׁמִיאָר 2760<sup>b</sup>  
 שְׁמִיאָה 2769<sup>a</sup>  
 שְׁמִיאל }  
 שְׁמִיאל } 1333<sup>b</sup>; 1864<sup>b</sup>  
 שְׁמִיאל 1864<sup>b</sup>  
 שְׁמִיאלִי 1864<sup>b</sup>  
 שְׁמִיָר 2748<sup>b</sup>  
 שְׁמִד 283<sup>a</sup>  
 שְׁמָה see שְׁמִים  
 שְׁמִיאל 2677<sup>a</sup>; 2678<sup>b</sup>; 2761<sup>a</sup>  
 שְׁמִיע 2749<sup>b</sup>  
 שְׁמִיעָה 866<sup>b</sup>; 1094<sup>a</sup>  
 שְׁמִח 1098<sup>a</sup>  
 שְׁמִחָה 600<sup>b</sup>; 1755<sup>a</sup>  
 שְׁמִחָה 1755<sup>a</sup>  
 שְׁמִיט 2556<sup>b</sup>  
 שְׁמִיטָה 2556<sup>b</sup>; 2635<sup>a</sup>  
 שְׁמִי 2749<sup>b</sup>  
 שְׁמִידָע 2760<sup>b</sup>  
 שְׁמִיכָה 2625<sup>b</sup>  
 שְׁמִים } 493<sup>a</sup>; 887<sup>a</sup>; 1352<sup>b</sup>;  
 שְׁמִים } 1433<sup>b</sup>; 2814<sup>b</sup>  
 שְׁמִינִית 2096<sup>a</sup>; 2488<sup>b</sup>  
 שְׁמִיר 54<sup>a</sup>; 2749<sup>a</sup>; 2858<sup>b</sup>;  
 2860<sup>a</sup>; 2862<sup>a</sup>;  
 2974<sup>b</sup>  
 שְׁמִירָמוֹת }  
 שְׁמִירָמוֹת } 2761<sup>a</sup>  
 שְׁמִירָמוֹת }  
 שְׁמִירָמוֹת } 422<sup>a</sup>; 669<sup>a</sup>; 876<sup>a</sup>;  
 שְׁמִירָמוֹת } 1147<sup>a</sup>; 2917<sup>b</sup>

שְׁמִלָה 2674<sup>b</sup>  
 שְׁמִלִי 2663<sup>b</sup>  
 שְׁמִם 833<sup>a</sup>; 1050<sup>b</sup>  
 שְׁמִמִית 1906<sup>a, b</sup>; 1907<sup>a</sup>;  
 2415<sup>b</sup>; 2840<sup>b</sup>  
 שְׁמִין 1985<sup>b</sup>  
 שְׁמִין 1101<sup>b</sup>; 2181<sup>b</sup>; 2183<sup>a</sup>;  
 2399<sup>a</sup>; 2639<sup>a, b</sup>  
 שְׁמִינִים }  
 שְׁמִינִים } 1142<sup>b</sup>  
 שְׁמִיע (שְׁמִיע) 526<sup>b</sup>; 851<sup>a</sup>; 1088<sup>a</sup>;  
 2112<sup>a</sup>; 2117<sup>a</sup>;  
 2154<sup>b</sup>; 2175<sup>a</sup>;  
 2793<sup>a</sup>; 2795<sup>b</sup>;  
 2877<sup>b</sup>; 2923<sup>b</sup>;  
 3110<sup>a</sup>  
 שְׁמִיע 2759<sup>b</sup>  
 שְׁמִיע 526<sup>b</sup>; 1094<sup>a</sup>  
 שְׁמִיע 1094<sup>a</sup>  
 שְׁמִיע 2759<sup>b</sup>  
 שְׁמִיע 2748<sup>a</sup>  
 שְׁמִיעָה 2769<sup>a</sup>  
 שְׁמִיעָה 2759<sup>b</sup>  
 שְׁמִיעוֹן 2770<sup>b</sup>; 2793<sup>a</sup>; 2794<sup>a</sup>;  
 2795<sup>b</sup>  
 שְׁמִיעִי 2770<sup>a</sup>  
 שְׁמִיעָה }  
 שְׁמִיעָה } 2759<sup>b</sup>  
 שְׁמִיעָה }  
 שְׁמִיעָה 2769<sup>a</sup>  
 שְׁמִיעָתִי 2769<sup>a</sup>  
 שְׁמִיר 97<sup>b</sup>; 1367<sup>a</sup>; 1791<sup>a</sup>;  
 2177<sup>b</sup>; 3074<sup>a</sup>  
 שְׁמִיר 875<sup>b</sup>; 2760<sup>b</sup>; 2769<sup>a</sup>;  
 3087<sup>b</sup>  
 שְׁמִיר 2256<sup>b</sup>  
 שְׁמִיר see שְׁמִיר  
 שְׁמִירָה 3074<sup>a</sup>  
 שְׁמִירוֹן 2771<sup>a</sup>  
 שְׁמִירוֹן 2671<sup>a</sup>; 2672<sup>b</sup>; 2760<sup>b</sup>  
 שְׁמִירוֹן }  
 שְׁמִירוֹן } 2771<sup>a</sup>  
 שְׁמִירָאוֹן }  
 שְׁמִירָי 2770<sup>b</sup>  
 שְׁמִירָה }  
 שְׁמִירָה } 2760<sup>b</sup>  
 שְׁמִירָמוֹת see שְׁמִירָמוֹת  
 שְׁמִירָת 2769<sup>a</sup>; 2771<sup>a</sup>  
 שְׁמִירָנִי 2673<sup>b</sup>  
 שְׁמִירָת 2770<sup>b</sup>  
 שְׁמִישׁ 301<sup>b</sup>; 596<sup>b</sup>; 1376<sup>b</sup>;  
 2675<sup>a</sup>; 2771<sup>a</sup>;  
 3082<sup>a</sup>

שְׂמִינִי 2675<sup>a</sup>  
 שְׂמִינִי 2675<sup>b</sup>; 2771<sup>a</sup>  
 שְׂמִינִי 2749<sup>b</sup>  
 שְׂמִינִי 2781<sup>b</sup>  
 שֵׁן 737<sup>a</sup>; 1127<sup>b</sup>; 1544<sup>b</sup>;  
 1622<sup>a</sup>; 2761<sup>a</sup>;  
 3000<sup>b</sup>  
 שְׂנָא 944<sup>b</sup>; 1343<sup>b</sup>  
 שְׂנָא see שְׂנָה  
 שְׂנָאב 2771<sup>a</sup>  
 שְׂנָה 1343<sup>b</sup>  
 שְׂנָאָא 2761<sup>a</sup>  
 שְׂנָה (שְׂנָה) 542<sup>a</sup>; 870<sup>b</sup>; 1756<sup>a</sup>;  
 2634<sup>b</sup>; 2635<sup>a</sup>;  
 2904<sup>b</sup>; 2961<sup>a</sup>;  
 2982<sup>a</sup>; 3024<sup>b</sup>;  
 3025<sup>a</sup>; 3126<sup>a</sup>  
 שְׂנָה 3126<sup>a</sup>  
 שְׂנָה } 2817<sup>a</sup>  
 שְׂנָא }  
 שְׂנָה בַיִם 1544<sup>b</sup>  
 שְׂנִי 884<sup>a</sup>; 2701<sup>b</sup>; 3109<sup>a</sup>  
 שְׂנִי 2961<sup>b</sup>  
 שְׂנִיר } 2720<sup>a</sup>; 2761<sup>a</sup>  
 שְׂנִיר }  
 שְׂנִיעַר 2771<sup>a, b</sup>  
 שְׂסַע 671<sup>a</sup>  
 שְׂעָה 798<sup>b</sup>; 1434<sup>a</sup>; 2982<sup>a</sup>  
 שְׂעוּר } see { שְׂעַר  
 שְׂעוּרָה } שְׂעָרָה  
 שְׂעִטָּה 1894<sup>b</sup>; 2867<sup>b</sup>  
 שְׂעוּר } 690<sup>b</sup>; 1248<sup>b</sup>; 1424<sup>a</sup>;  
 שְׂעוּר } 1533<sup>b</sup>; 1548<sup>b</sup>;  
 שְׂעַר } 1797<sup>b</sup>; 2144<sup>a</sup>;  
 שְׂעַר } 2145<sup>a</sup>; 2697<sup>a</sup>;  
 2713<sup>a</sup>; 3084<sup>b</sup>  
 שְׂעִירָה 2713<sup>a</sup>  
 שְׂעַל 1334<sup>b</sup>; 1404<sup>b</sup>  
 שְׂעַל see שְׂעַל  
 שְׂעַלְבִים } 2745<sup>a</sup>  
 שְׂעַלְבִין }  
 שְׂעַלְבִין 2745<sup>a</sup>  
 שְׂעַלִים 2745<sup>a</sup>  
 שְׂעַע 782<sup>a</sup>; 820<sup>a, b</sup>  
 שְׂעָה see קְעָה  
 שְׂעָה 2745<sup>a</sup>  
 שְׂעַר 1423<sup>a</sup>  
 שְׂעַר 2515<sup>b</sup>  
 שְׂעַר 1320<sup>a</sup>

שְׂעַר 416<sup>a</sup>; 1175<sup>b</sup>; 1325<sup>b</sup>;  
 1607<sup>b</sup>; 2062<sup>b</sup>;  
 2758<sup>a</sup>; 2769<sup>a</sup>;  
 2986<sup>a</sup>; 3045<sup>b</sup>  
 שְׂעַר see שְׂעִיר  
 שְׂעַר } 375<sup>b</sup>; 1320<sup>a</sup>; 1423<sup>a</sup>  
 שְׂעַר }  
 שְׂעַר see שְׂעִיר  
 שְׂעָרָה 2929<sup>b</sup>  
 שְׂעָרָה }  
 שְׂעָרָה } 405<sup>a</sup>; 1122<sup>a</sup>; 2721<sup>a</sup>  
 שְׂעָרָה }  
 שְׂעָרָה }  
 שְׂעָרָה } 1423<sup>a</sup>  
 שְׂעָרָה }  
 שְׂעָרָה } 2752<sup>b</sup>  
 שְׂעָרָה } 2745<sup>a</sup>  
 שְׂעָרָה } see שְׂעָרָה  
 שְׂעָרָה }  
 שְׂעָרָה } 2745<sup>b</sup>  
 שְׂעָרָה } 782<sup>a</sup>; 820<sup>b</sup>  
 שְׂעָרָה } 382<sup>a</sup>; 383<sup>a</sup>; 504<sup>a</sup>;  
 שְׂעָרָה } 522<sup>a</sup>; 523<sup>a</sup>; 899<sup>a</sup>;  
 שְׂעָרָה } 1896<sup>a</sup>; 2779<sup>b</sup>  
 שְׂעָרָה } 2764<sup>a</sup>  
 שְׂעָרָה } 2764<sup>a</sup>  
 שְׂעָרָה } 495<sup>a</sup>; 1202<sup>a</sup>; 1335<sup>a</sup>;  
 שְׂעָרָה } 1967<sup>b</sup>; 2556<sup>b</sup>;  
 3082<sup>a</sup>  
 שְׂעָרָה } 340<sup>a</sup>; 698<sup>a</sup>; 725<sup>b</sup>;  
 שְׂעָרָה } 1287<sup>a</sup>; 1759<sup>a</sup>;  
 שְׂעָרָה } 1771<sup>b</sup>; 1772<sup>a</sup>;  
 שְׂעָרָה } 1965<sup>a</sup>; 2200<sup>b</sup>;  
 שְׂעָרָה } 2408<sup>a</sup>; 2534<sup>b</sup>;  
 3010<sup>b</sup>  
 שְׂעָרָה } 1965<sup>a</sup>  
 שְׂעָרָה } 2750<sup>a</sup>  
 שְׂעָרָה } 2762<sup>a</sup>  
 שְׂעָרָה } 2774<sup>a</sup>  
 שְׂעָרָה } see שְׂעָרָה  
 שְׂעָרָה } 2782<sup>a</sup>  
 שְׂעָרָה } 55<sup>a</sup>; 2737<sup>b</sup>  
 שְׂעָרָה } 2690<sup>b</sup>; 2750<sup>a</sup>  
 שְׂעָרָה } 1087<sup>b</sup>  
 שְׂעָרָה } 2756<sup>b</sup>  
 שְׂעָרָה } 2030<sup>a</sup>  
 שְׂעָרָה } 3<sup>b</sup>; 1439<sup>b</sup>; 3045<sup>a</sup>

שְׂפַל 3<sup>b</sup>; 411<sup>a</sup>  
 שְׂפַל 411<sup>a</sup>  
 שְׂפַלָּה 381<sup>b</sup>; 411<sup>a</sup>; 724<sup>b</sup>;  
 1763<sup>a</sup>; 1934<sup>b</sup>;  
 2197<sup>a</sup>; 2209<sup>a</sup>;  
 2220<sup>a</sup>; 2227<sup>a</sup>;  
 2377<sup>b</sup>; 2407<sup>a</sup>;  
 2762<sup>a</sup>; 3045<sup>a</sup>  
 שְׂפַם 403<sup>a</sup>; 418<sup>a</sup>; 1896<sup>a</sup>  
 שְׂפַם 2749<sup>b</sup>  
 שְׂפַמּוֹת 2806<sup>a</sup>  
 שְׂפַן 3007<sup>b</sup>  
 שְׂפַן 698<sup>b</sup>; 1339<sup>a</sup>; 2596<sup>b</sup>;  
 2749<sup>b</sup>  
 שְׂפַע 17<sup>b</sup>  
 שְׂפַעִי 2774<sup>a</sup>  
 שְׂפַק see קְפַק  
 שְׂפַר 1278<sup>b</sup>  
 שְׂפַר 2763<sup>a</sup>  
 שְׂפַר see שְׂפַר  
 שְׂפַרָה 1175<sup>b</sup>  
 שְׂפַרָה 2774<sup>a</sup>  
 שְׂפַרָה 2293<sup>a</sup>; 2624<sup>b</sup>  
 שְׂפַת 943<sup>b</sup>; 1419<sup>a</sup>  
 שְׂק 1865<sup>a</sup>  
 שְׂקַד 1343<sup>a</sup>  
 שְׂקַד 100<sup>a</sup>; 1123<sup>a</sup>  
 שְׂקִיר 1999<sup>b</sup>  
 שְׂקִירָה } 15<sup>b</sup>; 16<sup>b</sup>; 612<sup>a</sup>; 834<sup>a</sup>  
 שְׂקִירָה }  
 שְׂקַט 1447<sup>b</sup>; 1965<sup>a</sup>; 2515<sup>b</sup>;  
 2743<sup>b</sup>  
 שְׂקַל 2535<sup>b</sup>; 3079<sup>a</sup>  
 שְׂקַל 605<sup>a</sup>; 2032<sup>b</sup>; 2076<sup>b</sup>;  
 2078<sup>a, b</sup>; 2758<sup>a, b</sup>;  
 3081<sup>a</sup>  
 שְׂקַם } 1123<sup>a</sup>; 2877<sup>a</sup>  
 שְׂקַמָּה }  
 שְׂקַרְרָה 1404<sup>b</sup>; 2864<sup>a</sup>  
 שְׂקַרְרָה } 6<sup>b</sup>; 16<sup>b</sup>  
 שְׂקַרְרָה } 15<sup>b</sup>; 834<sup>a</sup>  
 שְׂקַרְרָה } see שְׂקַרְרָה  
 שְׂקַרְרָה } 208<sup>b</sup>; 1788<sup>b</sup>; 2530<sup>a</sup>  
 שְׂקַרְרָה } 746<sup>b</sup>; 748<sup>b</sup>; 1105<sup>a</sup>;  
 1887<sup>a</sup>; 2876<sup>b</sup>  
 שְׂר 569<sup>a</sup>; 606<sup>a</sup>; 1289<sup>b</sup>;  
 1307<sup>b</sup>; 1929<sup>b</sup>;  
 2438<sup>b</sup>; 2453<sup>b</sup>;  
 2454<sup>b</sup>; 2626<sup>a</sup>;  
 2690<sup>b</sup>; 2732<sup>a</sup>;  
 2917<sup>a</sup>; 3134<sup>b</sup>  
 שְׂר 2122<sup>b</sup>; see also שְׂר

שְׂרָאָאָר } 2750<sup>a</sup>  
 שְׂרָאָאָר }  
 שְׂרָב } 1352<sup>a</sup>; 2247<sup>b</sup>  
 שְׂרַבְיָה } 2764<sup>b</sup>  
 שְׂרַבִּיט } 2701<sup>b</sup>  
 שְׂרַד } 2742<sup>b</sup>  
 שְׂרַד } 1894<sup>a</sup>; 2178<sup>a</sup>; 3119<sup>a</sup>  
 שְׂרַה } 1821<sup>b</sup>; 2454<sup>b</sup>; 2513<sup>b</sup>;  
 2690<sup>b</sup>  
 שְׂרַה } 576<sup>b</sup>  
 שְׂרַה } 512<sup>b</sup>; 513<sup>a</sup>  
 שְׂרַוּג } 2738<sup>b</sup>  
 שְׂרַוּחַן } 2751<sup>a</sup>  
 שְׂרַוּחַן } 1840<sup>b</sup>; 2779<sup>a, b</sup>  
 שְׂרַוּן } 1840<sup>a</sup>; 2750<sup>b</sup>  
 שְׂרַוּנִי } 2751<sup>a</sup>  
 שְׂרַוּקָה } 1395<sup>b</sup>  
 שְׂרַוּקָה }  
 שְׂרַח } 2732<sup>a</sup>  
 שְׂרַט } 769<sup>b</sup>; 770<sup>a</sup>  
 שְׂרַטָּת }  
 שְׂרַי } 2690<sup>b</sup>  
 שְׂרַי } 2750<sup>a</sup>  
 שְׂרַיג } 513<sup>b</sup>  
 שְׂרַיִד } 2692<sup>b</sup>  
 שְׂרַיָּה } 2732<sup>a</sup>  
 שְׂרַיָּה }  
 שְׂרַיִן }  
 שְׂרַיִן }  
 שְׂרַרְן } 253<sup>b</sup>; 254<sup>a</sup>; 1340<sup>b</sup>  
 שְׂרַרְיָה }  
 שְׂרַרְיָה }  
 שְׂרַרְיִן } 2812<sup>b</sup>  
 שְׂרַרְיִן }  
 שְׂרַרְקָה } 1110<sup>b</sup>; 1395<sup>b</sup>  
 שְׂרַרְרוּת } 1456<sup>a</sup>; 1941<sup>b</sup>; 1942<sup>a</sup>  
 שְׂרַרְסָבִים } 2693<sup>b</sup>  
 שְׂרַרַע } 2871<sup>a</sup>  
 שְׂרַרַה } 744<sup>a</sup>; 2692<sup>a</sup>; 2732<sup>a</sup>;  
 2737<sup>a</sup>  
 שְׂרַרַם } 2692<sup>a</sup>; 2703<sup>b</sup>; 2732<sup>a</sup>;  
 2737<sup>a</sup>  
 שְׂרַרַץ } 518<sup>a</sup>; 522<sup>b</sup>; 744<sup>a</sup>  
 שְׂרַרַץ } 425<sup>a</sup>; 739<sup>a</sup>; 743<sup>b</sup>;  
 744<sup>a</sup>  
 שְׂרַק } 1395<sup>b</sup>  
 שְׂרַק }  
 שְׂרַק } 2836<sup>b</sup>; 3050<sup>a</sup>  
 שְׂרַקָה }

שְׂרַקָה } 1395<sup>b</sup>  
 שְׂרַר } 944<sup>b</sup>  
 שְׂרַר } 2122<sup>b</sup>  
 שְׂרַרַשׁ } 510<sup>b</sup>; 2623<sup>a, b</sup>; 2764<sup>b</sup>  
 שְׂרַרַשׁ }  
 שְׂרַרְיָה } 589<sup>a</sup>  
 שְׂרַרַת } 2742<sup>b</sup>; 3063<sup>b</sup>  
 שְׂרַשׁ } 675<sup>b</sup>; 1111<sup>a</sup>; 1894<sup>a, b</sup>;  
 1984<sup>b</sup>; 1985<sup>a</sup>;  
 שְׂרַשׁ } 2089<sup>b</sup>; 2790<sup>b</sup>;  
 2791<sup>a</sup>  
 שְׂרַשׁ } 2766<sup>a</sup>  
 שְׂרַשׁוּן } 1755<sup>a</sup>  
 שְׂרַשׁוּן }  
 שְׂרַשׁי } 2751<sup>a</sup>  
 שְׂרַשׁי } 2766<sup>a</sup>  
 שְׂרַשׁים } 2813<sup>b</sup>  
 שְׂרַשׁי } 1590<sup>b</sup>; 2765<sup>b</sup>  
 שְׂרַשׁוּן } 2766<sup>a</sup>  
 שְׂרַשׁוּן } see שְׂרַשׁוּן  
 שְׂרַשׁק } 2751<sup>a</sup>  
 שְׂרַשׁר } 676<sup>a</sup>  
 שְׂרַת } 2743<sup>b</sup>  
 שְׂרַתָּה } 1141<sup>b</sup>  
 שְׂרַתִּי } 880<sup>b</sup>  
 שְׂרַתִּי } 3072<sup>a, b</sup>; 3077<sup>a</sup>  
 שְׂרַתִּים } see שְׂרַתִּים  
 שְׂרַתִּן } 1971<sup>b</sup>; 1980<sup>b</sup>  
 שְׂרַתִּר } 2766<sup>a</sup>  
 שְׂרַתִּר בּוֹזְזִי } 2766<sup>b</sup>  
 ר }  
 רָא } 144<sup>a</sup>; 1307<sup>b</sup>  
 רָאָה } 6<sup>b</sup>  
 רָאָה } see רָא  
 רָאָו } 143<sup>b</sup>; 144<sup>a</sup>; 584<sup>a</sup>;  
 3084<sup>b</sup>; 3155<sup>b</sup>;  
 רָאָו } 3156<sup>a</sup>  
 רָאָוּה } 1941<sup>b</sup>; 1942<sup>a</sup>  
 רָאָוִם } 817<sup>b</sup>; 2973<sup>a</sup>  
 רָאָם } 2208<sup>a</sup>  
 רָאָם } see רָאָוִם  
 רָאָן } 1108<sup>b</sup>; 1122<sup>a</sup>  
 רָאָנָה } 1354<sup>b</sup>  
 רָאָנָה } 2887<sup>a</sup>  
 רָאָר } 1985<sup>b</sup>

רָאָר } 1136<sup>a</sup>  
 רָאָרַע } 2910<sup>a</sup>  
 רָאָשׁוּר } 512<sup>a</sup>  
 רָבָה } 242<sup>a</sup>  
 רָבִיָּה } 1153<sup>b</sup>; 2587<sup>a</sup>  
 רָבִין } 2191<sup>a</sup>; 3089<sup>a</sup>  
 רָבִיָּה }  
 רָבִיָּה } 345<sup>a</sup>; 2172<sup>b</sup>; 2901<sup>a</sup>;  
 2902<sup>a</sup>  
 רָבִל } 700<sup>b</sup>; 747<sup>a</sup>  
 רָבִל } 3106<sup>a</sup>  
 רָבִל } see רָבִל  
 רָבִלָל } 486<sup>b</sup>  
 רָבִן } 588<sup>b</sup>; 1424<sup>a</sup>; 2866<sup>b</sup>;  
 2867<sup>b</sup>  
 רָבִנִי } 2980<sup>a</sup>  
 רָבִנִית } 1109<sup>b</sup>; 1136<sup>a</sup>; 2264<sup>b</sup>  
 רָבִרָה } 2887<sup>b</sup>  
 רָבִר } 2965<sup>a</sup>  
 רָבִלָת }  
 רָבִלָת } 2980<sup>b</sup>  
 רָבִלָת }  
 רָבִלָת }  
 רָבִלָת } see רָבִלָת  
 רָבִרָה } 2399<sup>a</sup>  
 רָבִרָה } 705<sup>a</sup>  
 רָבִרָה } 2902<sup>a</sup>  
 רָבִרָה } 2980<sup>a</sup>  
 רָבִרָה } 665<sup>a</sup>; 700<sup>b</sup>; 831<sup>b</sup>;  
 941<sup>b</sup>; 1136<sup>a</sup>;  
 2156<sup>b</sup>; 2309<sup>a</sup>  
 רָבִרָה } 26<sup>b</sup>; 315<sup>b</sup>; 316<sup>a</sup>;  
 817<sup>a</sup>; 3081<sup>b</sup>;  
 3106<sup>b</sup>; 3108<sup>b</sup>  
 רָבִרָה } 2429<sup>a</sup>; 2487<sup>a</sup>  
 רָבִרָה } 1125<sup>a</sup>  
 רָבִרָה } see רָבִרָה  
 רָבִרָה } 1147<sup>b</sup>  
 רָבִר } 1986<sup>a</sup>; 2704<sup>b</sup>  
 רָבִל } 3027<sup>b</sup>  
 רָבִל } 3027<sup>b</sup>  
 רָבִל } see רָבִל  
 רָבִלָה } 1354<sup>b</sup>  
 רָבִלָה } 2993<sup>b</sup>

תֹּדָה 2429<sup>a</sup>; 2639<sup>a</sup>; 2644<sup>b</sup>  
 תָּהָה 2704<sup>a, b</sup>  
 תֹּדָה } 511<sup>a</sup>; 1417<sup>b</sup>; 2050<sup>a</sup>;  
 תָּהָה } see also תָּהָה  
 תֹּדָה see תָּהָה  
 תֹּלְדָה } 1058<sup>a</sup>; 1183<sup>b</sup>; 1199<sup>a</sup>;  
 תָּלְדָה } 1200<sup>b</sup>; 1494<sup>b</sup>  
 תֹּלַע }  
 תֹּלְעָה } 675<sup>b</sup>; 676<sup>a</sup>; 884<sup>a</sup>;  
 תֹּלְעַת } 2701<sup>b</sup>; 2994<sup>a</sup>;  
 תֹּלְעַת } 3109<sup>a</sup>  
 תֹּלְעָה }  
 תֹּלְעָה } 15<sup>b</sup>; 834<sup>a</sup>  
 תֹּלְעָה }  
 תֹּלְעָה } 504<sup>a</sup>; 1273<sup>a</sup>; 1542<sup>b</sup>;  
 תֹּלְעָה } 2205<sup>a</sup>  
 תֹּלְקָה } 2981<sup>b</sup>  
 תֹּלְקָה }  
 תֹּר } 594<sup>b</sup>; 831<sup>b</sup>; 2530<sup>a</sup>;  
 תֹּר } 3002<sup>a</sup>  
 תֹּר } 504<sup>a</sup>; 583<sup>b</sup>; 871<sup>b</sup>  
 תֹּר }  
 תֹּר } 408<sup>a</sup>; 430<sup>b</sup>; 555<sup>a</sup>;  
 תֹּר } 902<sup>a</sup>; 1256<sup>b</sup>;  
 תֹּר } 1536<sup>b</sup>; 1539<sup>b</sup>;  
 תֹּר } 1852<sup>a, b</sup>; 1854<sup>a</sup>;  
 תֹּר } 1857<sup>b</sup>; 1983<sup>a</sup>;  
 תֹּר } 2298<sup>b</sup>; 2581<sup>b</sup>;  
 תֹּר } 2582<sup>a</sup>  
 תֹּשֵׁב } 1128<sup>a</sup>; 2467<sup>b</sup>; 2556<sup>b</sup>;  
 תֹּשֵׁב } 2865<sup>a, b</sup>; 2866<sup>a</sup>  
 תֹּשֵׁה } 1682<sup>b</sup>; 2474<sup>b</sup>; 2475<sup>b</sup>;  
 תֹּשֵׁה } 2476<sup>a</sup>; 3089<sup>a</sup>  
 תֹּזְנִית } 746<sup>b</sup>; 748<sup>b</sup>  
 תֹּזְנִית }  
 תֹּחֲכָמִי 2902<sup>b</sup>  
 תֹּחֲלִיא } 1306<sup>b</sup>; 2783<sup>a</sup>  
 תֹּחֲלִיא }  
 תֹּחֲמִס 2143<sup>b</sup>  
 תֹּחֲזֵן 2902<sup>a</sup>  
 תֹּחֲפָה 2924<sup>a</sup>  
 תֹּחֲקִי 2902<sup>a</sup>  
 תֹּחֲפִיקָה }  
 תֹּחֲפִיקָה } 2902<sup>b</sup>; 2903<sup>a</sup>  
 תֹּחֲפִיקָה }  
 תֹּחֲפִיקָה }  
 תֹּחֲרָא 1313<sup>a</sup>  
 תֹּחֲרַע 2903<sup>a</sup>; 2910<sup>a</sup>  
 תֹּחֲשׁ } 376<sup>b</sup>; 377<sup>a</sup>; 2422<sup>a</sup>;  
 תֹּחֲשׁ } 2709<sup>b</sup>; 2710<sup>a</sup>;  
 תֹּחֲשׁ } 2814<sup>a</sup>; 2902<sup>b</sup>  
 תֹּחֲת 2850<sup>b</sup>; 2902<sup>b</sup>; 3037<sup>a</sup>

תֹּחֲתוֹן } 1789<sup>a</sup>  
 תֹּחֲתוֹן }  
 תֹּחֲמִיא } 2928<sup>b</sup>  
 תֹּחֲמִיא }  
 תֹּחֲמִין } 312<sup>b</sup>; 2838<sup>a</sup>; 2929<sup>a</sup>  
 תֹּחֲמִין }  
 תֹּחֲמִינִי 2929<sup>a</sup>  
 תֹּחֲמִינִי 2929<sup>a</sup>  
 תֹּחֲצֵן 2990<sup>a</sup>  
 תֹּירוֹשׁ } 2140<sup>b</sup>; 3086<sup>b</sup>  
 תֹּירוֹשׁ }  
 תֹּירָא 2986<sup>b</sup>  
 תֹּירָס 2986<sup>a</sup>  
 תֹּירוֹשׁ see תֹּירוֹשׁ  
 תֹּירֵשׁ 1249<sup>a</sup>  
 תֹּיָךְ } 1417<sup>b</sup>  
 תֹּיָךְ }  
 תֹּכֹרֶה 1098<sup>b</sup>; 2710<sup>b</sup>  
 תֹּכִי } 2294<sup>a</sup>  
 תֹּכִי }  
 תֹּכִיָּה 2321<sup>a</sup>  
 תֹּכִיָּה 2321<sup>a</sup>  
 תֹּכִיָּת 675<sup>b</sup>; 884<sup>a</sup>; 1146<sup>b</sup>  
 תֹּכֵן 968<sup>a</sup>; 3037<sup>b</sup>  
 תֹּכֵן 2904<sup>a</sup>; 2993<sup>b</sup>  
 תֹּל 1350<sup>b</sup>  
 תֹּל אָבִיב 2924<sup>a</sup>  
 תֹּלְאָה 3007<sup>a</sup>  
 תֹּלְאָשׁוּר } 2925<sup>a</sup>; 2965<sup>b</sup>  
 תֹּלְאָשׁוּר }  
 תֹּלַג 2819<sup>b</sup>  
 תֹּלְגַת see תֹּלְגַת  
 תֹּלְדָה see תֹּלְדָה  
 תֹּלָה 1335<sup>b</sup>  
 תֹּלַח 2925<sup>a</sup>  
 תֹּלַח 2925<sup>a</sup>  
 תֹּלִי 2515<sup>b</sup>  
 תֹּלִל 941<sup>a</sup>  
 תֹּלִם 1150<sup>a</sup>  
 תֹּלְמִי 2904<sup>a</sup>  
 תֹּל מֶלֶח 2928<sup>b</sup>  
 תֹּלְעַת see תֹּלְעַת  
 תֹּלְפִיָּה 254<sup>b</sup>  
 תֹּלְפִיָּה see תֹּלְפִיָּה  
 תֹּלְתַל 533<sup>a</sup>  
 תֹּלְתַל } 2320<sup>b</sup>; 2407<sup>a</sup>; 2515<sup>b</sup>;  
 תֹּלְתַל } 3037<sup>a</sup>  
 תֹּלְתַל }  
 תֹּלְתַל } 1484<sup>a</sup>; 2321<sup>a</sup>; 2798<sup>a</sup>

תֹּמֵא see תֹּמֵא  
 תֹּמֵה 1484<sup>a</sup>  
 תֹּמֵה 2001<sup>a</sup>  
 תֹּמֵה 372<sup>a</sup>; 541<sup>b</sup>; 2908<sup>a</sup>;  
 תֹּמֵה } 2964<sup>b</sup>  
 תֹּמֵל } 1375<sup>b</sup>  
 תֹּמֵל }  
 תֹּמוֹנָה } 1254<sup>a</sup>; 2794<sup>b</sup>  
 תֹּמֵה }  
 תֹּמַח 2929<sup>a</sup>  
 תֹּמִיד 112<sup>b</sup>; 705<sup>a</sup>; 1057<sup>b</sup>;  
 תֹּמִיד } 1063<sup>a</sup>; 2323<sup>a</sup>  
 תֹּמִים 2320<sup>b</sup>; 2804<sup>b</sup>; 2846<sup>b</sup>;  
 תֹּמִים } 3141<sup>b</sup>  
 תֹּמִים 1484<sup>a</sup>; 3040<sup>b</sup>  
 תֹּמֵךְ 1403<sup>a</sup>; 2569<sup>b</sup>  
 תֹּמֵל see תֹּמֵל  
 תֹּמֵם 704<sup>b</sup>  
 תֹּמֵן see תֹּמֵן  
 תֹּמֵה 2972<sup>b</sup>; 2983<sup>a</sup>  
 תֹּמֵה see תֹּמוֹנָה  
 תֹּמֵי 2929<sup>a</sup>; 2983<sup>b</sup>  
 תֹּמֵק 2983<sup>a</sup>  
 תֹּמֵת קָרָס } 2983<sup>a</sup>  
 תֹּמֵת סָרַח }  
 תֹּמֵר 665<sup>b</sup>; 1123<sup>a, b</sup>; 1350<sup>b</sup>;  
 תֹּמֵר } 2235<sup>a</sup>; 2907<sup>b</sup>  
 תֹּמֵר 2236<sup>b</sup>  
 תֹּמֵר } 2235<sup>b</sup>  
 תֹּמֵר }  
 תֹּמֵר see תֹּמֵר  
 תֹּמֵרוֹק }  
 תֹּמֵרוֹק } 667<sup>b</sup>  
 תֹּמֵרוֹק }  
 תֹּמֵרוֹר 483<sup>b</sup>; 1350<sup>b</sup>  
 תֹּמֵרוֹק } see תֹּמֵרוֹק  
 תֹּמֵרוֹק }  
 תֹּמֵה 2550<sup>b</sup>  
 תֹּמֵה 873<sup>a</sup>; 3082<sup>a</sup>  
 תֹּמֵה 514<sup>b</sup>  
 תֹּמֵה 2639<sup>a, b</sup>; 2643<sup>b</sup>  
 תֹּמֵר 515<sup>b</sup>  
 תֹּמֵמַת 2908<sup>b</sup>  
 תֹּמֵן } 427<sup>a</sup>; 428<sup>b</sup>; 873<sup>a</sup>;  
 תֹּמֵן } 1548<sup>a, b</sup>; 2144<sup>a</sup>;  
 תֹּמֵן } 2525<sup>b</sup>; 2697<sup>a</sup>;  
 תֹּמֵן } 2707<sup>a</sup>; 2737<sup>a</sup>;  
 תֹּמֵן } 3075<sup>b</sup>; 3082<sup>a</sup>;  
 תֹּמֵן } 3084<sup>b</sup>

תְּנַשְׂמָה 592<sup>a</sup>; 1826<sup>b</sup>; 1906<sup>a, b</sup>;  
2074<sup>a</sup>; 2874<sup>b</sup>  
תָּעַב 6<sup>b</sup>  
תְּעַבְדָּה see תוֹעַבְדָּה  
תָּעָה 748<sup>a</sup>; 970<sup>b</sup>; 2712<sup>a</sup>  
תָּעַי } 3000<sup>b</sup>  
תָּעַי }  
תָּעַלָּה 1349<sup>b</sup>; 3074<sup>b</sup>  
תְּעַלְלוּ 348<sup>b</sup>; 826<sup>a</sup>  
תְּעַנִּית 1103<sup>a</sup>; 1354<sup>b</sup>  
תְּעַנְנָה } 2887<sup>a</sup>; 2908<sup>b</sup>  
תְּעַנְנָה }  
תָּעַר 1815<sup>b</sup>; 2533<sup>b</sup>  
תָּה 2095<sup>a</sup>; 2097<sup>a</sup>; 2101<sup>a</sup>  
תְּפַאֲרָה } 514<sup>a</sup>; 1235<sup>b</sup>  
תְּפַאֲרָת }  
תְּפַנֵּחַ 209<sup>a, b</sup>; 1123<sup>a</sup>; 2220<sup>a</sup>;  
2909<sup>a, b</sup>  
תָּפַל 1125<sup>a</sup>; 3038<sup>b</sup>  
תָּפַל 2999<sup>a</sup>  
תְּפַלָּה 1125<sup>a</sup>; 1681<sup>b</sup>  
תְּפַלָּה 2393<sup>a</sup>; 2487<sup>a</sup>  
תְּפַסֵּחַ 2985<sup>b</sup>  
תָּפַח 2887<sup>b</sup>  
תָּפַח 2999<sup>b</sup>  
תְּפַתִּי 2765<sup>b</sup>

תוֹצְאָה see תוֹצְאָה  
תִּקְוָה 1419<sup>b</sup>; 2981<sup>b</sup>  
תִּקְוֵעַ 2924<sup>a</sup>  
תִּקְוֵי } 2924<sup>a</sup>  
תִּקְוֵי }  
תִּקְוֵיפָה } 656<sup>b</sup>; 943<sup>a</sup>  
תִּקְוֵיפָה }  
תִּקְל 2032<sup>a</sup>; 2924<sup>a</sup>  
תִּקְוָן 896<sup>b</sup>; 2200<sup>b</sup>  
תִּקְוֵעַ 490<sup>b</sup>; 665<sup>b</sup>; 2399<sup>a</sup>;  
2872<sup>a</sup>  
תִּקְוֵי see תִּקְוֵי  
תִּקְוָה 333<sup>a</sup>; 334<sup>b</sup>  
תִּקְוֵיפָה see תִּקְוֵיפָה  
תִּר see תוֹר  
תִּרְאָלָה 2909<sup>b</sup>  
תִּרְה see תוֹרְה  
תִּרְנָמָה 2817<sup>b</sup>  
תִּרְהָקָה 1387<sup>a</sup>; 2986<sup>a</sup>  
תִּרְוָמָה } 1228<sup>b</sup>; 2177<sup>b</sup>;  
תִּרְוָמָה } 2639<sup>a, b</sup>; 2643<sup>b</sup>  
תִּרְוֵיפָה 89<sup>b</sup>; 305<sup>a</sup>  
תִּרְוֵיפָה 2026<sup>a</sup>  
תִּרְזָה 1405<sup>a</sup>  
תִּרְח 2948<sup>b</sup>

תִּרְחָמָה 2986<sup>b</sup>  
תִּרְמָה } 2999<sup>b</sup>  
תִּרְמִית }  
תִּרְמִית }  
תִּרְוָמָה see תִּרְוָמָה  
תִּרְוָן 417<sup>a</sup>  
תִּרְע 1175<sup>b</sup>; 2769<sup>b</sup>; 2986<sup>a</sup>  
תִּרְעָהוּ 2986<sup>a</sup>  
תִּרְפִּים 1270<sup>b</sup>; 1390<sup>b</sup>; 1447<sup>b</sup>;  
1455<sup>a</sup>; 1551<sup>a</sup>  
תִּרְצָה 2987<sup>a</sup>  
תִּרְש 2949<sup>a</sup>  
תִּרְשִׁישׁ 2774<sup>a</sup>; 2856<sup>b</sup>; 2857<sup>a</sup>;  
2862<sup>a</sup>; 2914<sup>a</sup>;  
2965<sup>a</sup>  
תִּרְשָׁתָּה 1289<sup>b</sup>; 2132<sup>a</sup>; 2986<sup>b</sup>;  
2987<sup>a</sup>  
תִּרְתָּן 2917<sup>a</sup>  
תִּרְתָּק 2917<sup>a</sup>  
תִּרְשָׂה 764<sup>b</sup>; 2154<sup>b</sup>  
תִּרְשָׁב see תוֹשָׁב  
תִּרְשָׁבִין 523<sup>a</sup>; 940<sup>a</sup>  
תִּרְשָׁח see אֶל-תִּשְׁחַח  
תִּרְשִׁיה see תוֹשִׁייה  
תִּרְשִׁי 2917<sup>b</sup>  
תִּרְשִׁי' תִּרְשִׁי' תִּרְשִׁי'

## INDEX OF GREEK WORDS

- ἄβυσσος*, 26<sup>b</sup>; 511<sup>a</sup>; 992<sup>b</sup>  
*ἀγαθόν*, τὸ, 1014<sup>b</sup>  
*ἀγαλλίασις*, 1755<sup>a</sup>  
*ἀγαπάω*, 1932<sup>a</sup>  
*ἀγάπη*, 69<sup>b</sup>; 525<sup>b</sup>; 596<sup>b</sup>; 597<sup>a</sup>; 680<sup>a</sup>;  
 959<sup>a</sup>; 1829<sup>a</sup>; 1933<sup>a</sup>  
*ἀγαπητός*, 432<sup>b</sup>  
*ἀγαπεύω*, 695<sup>b</sup>  
*ἀγγελος*, 132<sup>b</sup>; 202<sup>b</sup>; 1913<sup>b</sup>  
*ἀγιασμός*, 2681<sup>b</sup>  
*ἄγιος*, 1404<sup>a</sup>; 2686<sup>b</sup>  
*ἄγνωστος*, 3037<sup>b</sup>  
*ἀγοράζω*, 533<sup>a</sup>  
*ἀγοραῖος*, 411<sup>a</sup>; 2522<sup>a</sup>  
*ἀγοράφα*, 72<sup>a</sup>  
*ἀγωνία*, 71<sup>b</sup>  
*ἀγών*, 71<sup>b</sup>; 1171<sup>b</sup>  
*ἀδάπανος* (LXX), 595<sup>a</sup>  
*ἀδημονέω*, 1354<sup>b</sup>  
*ἀδικία*, 2798<sup>b</sup>  
*ἀδίκιμος*, 582<sup>a</sup>; 724<sup>a</sup>; 2560<sup>b</sup>  
*ἄδντον*, 65<sup>a</sup>  
*ἀήρ*, 88<sup>b</sup>  
*ἄθεος*, 318<sup>b</sup>  
*ἀθετέω*, 137<sup>b</sup>  
*ἄδης*, 1314<sup>b</sup>; 2761<sup>a</sup>  
*ἄδιδιος*, 1010<sup>b</sup>; 1041<sup>a</sup>  
*αἰδώς*, 2748<sup>b</sup>  
*αἶμα*, 489<sup>a</sup>  
*αἶνυγμα*, 789<sup>a</sup>; 1170<sup>b</sup>  
*αἶρω*, 1823<sup>a</sup>  
*αἶρεσις*, 1377<sup>a</sup>; 2711<sup>b</sup>  
*αἰσθητήριον*, 2720<sup>b</sup>  
*αἰσχύνη* (LXX), 346<sup>a</sup>  
*αἰτέω*, 282<sup>b</sup>; 425<sup>b</sup>  
*αἶτλα*, 581<sup>b</sup>  
*αἰών*, 65<sup>b</sup>; 70<sup>b</sup>; 980<sup>b</sup>; 1010<sup>b</sup>; 2455<sup>a</sup>;  
 3108<sup>b</sup>  
*αἰώνιος*, 990<sup>b</sup>; 991<sup>b</sup>; 1010<sup>b</sup>; 1041<sup>a</sup>;  
 1702<sup>b</sup>; 2502<sup>a</sup>  
*ἀκάνθινος*, 763<sup>a</sup>  
*ἀκέραιος*, 2798<sup>a</sup>  
*ἀκριβής*, 1069<sup>a</sup>  
*ἀκριδες*, 892<sup>a</sup>  
*ἀκυρώω*, 137<sup>b</sup>  
*ἀλάβαστρον*, 89<sup>a</sup>; 512<sup>a</sup>  
*ἀλάστρωρ*, 1150<sup>b</sup>  
*ἀλέλω*, 138<sup>a</sup>  
*ἀλεκτοροφωλία*, 798<sup>b</sup>  
*ἀλήθεια*, 1090<sup>a</sup>; (LXX) 1484<sup>a</sup>;  
 1698<sup>a</sup>; 1712<sup>b</sup>  
*ἀληθής*, 1090<sup>a</sup>  
*ἀληθινός*, 1090<sup>a</sup>; 1712<sup>a</sup>; 1716<sup>b</sup>
- ἀλλάσσω*, 321<sup>b</sup>  
*ἀλληγορέω*, 21<sup>b</sup>; 98<sup>a</sup>  
*ἀλληγορία*, 97<sup>b</sup>  
*ἄλλος*, 989<sup>a</sup>  
*ἀλλοτριεπίσκοπος*, 533<sup>a</sup>  
*ἀλλότριος*, 97<sup>a</sup>  
*ἄλογος*, 526<sup>b</sup>  
*ἄλος*, 268<sup>b</sup>  
*ἄλφα*, 103<sup>b</sup>  
*ἄλωπηξ*, 1143<sup>a</sup>  
*ἄμαρτάνω*, 2798<sup>b</sup>  
*ἄμαρτημα*, 1016<sup>b</sup>  
*ἄμαρτια*, 1016<sup>b</sup>; 2498<sup>a</sup>  
*ἄμικτος*, 3037<sup>a</sup>  
*ἀναβλέπω*, 68<sup>a</sup>  
*ἀνάθεμα*, 130<sup>a</sup>  
*ἀνάθημα*, 1228<sup>b</sup>  
*ἀνασταυρώω*, 68<sup>a</sup>  
*ἀνάστασις*, 986<sup>b</sup>  
*ἀναστροφή*, 706<sup>b</sup>; 1828<sup>b</sup>  
*ἀνατολή*, 800<sup>a</sup>; 888<sup>b</sup>  
*ἀνδραποδιστής*, 747<sup>a</sup>  
*ἀνήρ*, 145<sup>a</sup>; 819<sup>b</sup>; 1442<sup>a</sup>; 2806<sup>a</sup>  
*ἀνθρακιά*, 671<sup>b</sup>  
*ἄνθραξ*, 671<sup>b</sup>  
*ἀνθρωπος*, 144<sup>b</sup>; 819<sup>b</sup>  
*ἀνθρώπατος*, 830<sup>b</sup>  
*ἀνίστημι*, 986<sup>a</sup>  
*ἀνομία*, 1093<sup>a</sup>; 1469<sup>a</sup>; 1713<sup>b</sup>  
*ἄνομος*, 1859<sup>a</sup>  
*ἀνοχή*, 1126<sup>b</sup>  
*ἀντιδικος*, 64<sup>b</sup>; 2693<sup>a</sup>  
*ἀντίθεος*, 155<sup>b</sup>  
*ἀντίκειμαι*, 64<sup>b</sup>  
*ἀντιληψις*, 1374<sup>a</sup>  
*ἀντίλυτρον*, 2654<sup>a</sup>  
*ἀντίτυπος*, 396<sup>a</sup>  
*ἀντίχριστος*, 154<sup>b</sup>  
*ἀπαλγέω*, 1105<sup>a</sup>  
*ἀπαρχή*, 1114<sup>a</sup>; 1416<sup>b</sup>  
*ἀπαύγασμα*, 522<sup>a</sup>; 1451<sup>b</sup>; 1914<sup>b</sup>  
*ἀπειθεία*, 3033<sup>a</sup>  
*ἀπελεύθεροι*, 1881<sup>a</sup>  
*ἀπιστία*, 3033<sup>a</sup>  
*ἄπιστος*, 1467<sup>a</sup>  
*ἀπλότης*, 511<sup>a</sup>  
*ἀπλούς*, 2805<sup>a</sup>  
*ἀποθήκη*, 405<sup>a</sup>  
*ἀποκαλύπτω*, 2581<sup>b</sup>  
*ἀποκάλυψις*, 981<sup>b</sup>; 983<sup>b</sup>; 2249<sup>a</sup>  
*ἀποκατάστασις*, 991<sup>a</sup>; 1756<sup>b</sup>; 2546<sup>b</sup>;  
 2562<sup>a</sup>  
*ἀπόκριφος*, 179<sup>a</sup>
- Ἀπολλών*, 201<sup>b</sup>  
*ἀπολούω*, 394<sup>b</sup>  
*ἀπολύτρωσις*, 2024<sup>a</sup>  
*ἀποπομπαῖος* (LXX), 343<sup>b</sup>  
*ἀποστάσιον*, 865<sup>a</sup>  
*ἀποστολή* (LXX), 409<sup>a</sup>  
*ἀπόστολος*, 202<sup>b</sup>  
*ἀποσυγγέω*, 6<sup>b</sup>  
*ἀπόλεια*, 780<sup>b</sup>; 991<sup>a</sup>; 2320<sup>b</sup>  
*ἀργύριον*, 2395<sup>a</sup>; 2792<sup>b</sup>  
*ἀριστερός*, 1334<sup>b</sup>  
*ἄριστον*, 385<sup>a</sup>; 849<sup>b</sup>  
*ἄρμα*, 595<sup>a</sup>  
*ἄρπαγμα*, 2457<sup>b</sup>  
*ἄρπαγμός*, 1293<sup>a</sup>; 2457<sup>b</sup>; 2595<sup>b</sup>  
*ἄρραβών*, 401<sup>a</sup>; 886<sup>b</sup>; 1416<sup>b</sup>  
*ἀρσενοκίτης*, 26<sup>b</sup>  
*ἄρσην*, 145<sup>a</sup>  
*ἄρτος*, 514<sup>b</sup>  
*ἀρχηγός*, 333<sup>a</sup>; 569<sup>a</sup>; 2453<sup>a</sup>; 2700<sup>b</sup>  
*ἀρχιτρίκλινος*, 385<sup>a</sup>; 2627<sup>a</sup>  
*ἀρχων*, 665<sup>b</sup>; 2453<sup>a</sup>  
*ἀσέλγεια*, 1003<sup>a</sup>; 1839<sup>b</sup>  
*ἀσκάς*, 509<sup>b</sup>; 2814<sup>a</sup>  
*ἀσπάλαθος*, 286<sup>b</sup>  
*ἄσπονδος*, 3024<sup>a</sup>  
*ἀσσάριον*, 1098<sup>b</sup>  
*ἀστεῖος*, 1087<sup>b</sup>  
*ἀστήρ*, 308<sup>b</sup>  
*ἀσύνθετος*, 1746<sup>a</sup>  
*ἀσφαλτος* (LXX), 2401<sup>b</sup>  
*ἄτακτος*, 855<sup>a</sup>  
*ἄτοπος*, 116<sup>b</sup>  
*αὐλή*, 2429<sup>a</sup>  
*αὐτάρκεια*, 2275<sup>a</sup>  
*αὐτόματος*, 33<sup>b</sup>  
*ἄφεςις*, 1132<sup>b</sup>; 2557<sup>b</sup>  
*ἀφίημι*, 24<sup>a</sup>  
*ἀφικνέομαι*, 22<sup>b</sup>
- βαῖτον*, 514<sup>a</sup>  
*βαπτίζω*, 385<sup>b</sup>; 386<sup>a</sup>; 387<sup>a</sup>; 388<sup>b</sup>;  
 390<sup>a</sup>; 394<sup>a</sup>; 395<sup>a</sup>; 399<sup>a</sup>; 415<sup>a</sup>;  
 1710<sup>a</sup>; 3011<sup>b</sup>  
*βάπτισμα*, 385<sup>b</sup>; 388<sup>b</sup>; 389<sup>a</sup>; 394<sup>a</sup>  
*βαπτισμός*, 385<sup>b</sup>; 388<sup>b</sup>; 389<sup>a</sup>; 394<sup>a</sup>  
*βάπτω*, 385<sup>b</sup>; 386<sup>a</sup>; 389<sup>a</sup>; 390<sup>a</sup>;  
 394<sup>a</sup>  
*βάρβαρος*, 402<sup>b</sup>  
*βάρος*, 528<sup>b</sup>  
*βασιλεύω*, 2553<sup>b</sup>  
*βασκαίνω*, 458<sup>b</sup>; 3097<sup>b</sup>  
*βάτος* (LXX), 532<sup>a</sup>

- βατταλογήω, 1964<sup>b</sup>; 2559<sup>b</sup>  
 βδέλυγμα, 16<sup>b</sup>  
 βδελύσσομαι, 6<sup>b</sup>  
 βῆμα, 1661<sup>b</sup>  
 βιαστής, 3051<sup>b</sup>  
 βιβλίον, 459<sup>b</sup>; 2597<sup>a</sup>  
 βίβλος, 495<sup>b</sup>  
 βίβλος γενέσεως, 1183<sup>b</sup>  
 βίβλος τῆς ζωῆς, 503<sup>a</sup>  
 βίος, 1889<sup>a</sup>  
 βλασφημία, 485<sup>b</sup>  
 βουλευτής, 723<sup>b</sup>; 2689<sup>b</sup>  
 βούλημα, 3085<sup>a</sup>  
 βούλωμαι, 3085<sup>a</sup>  
 βροτός, 145<sup>a</sup>  
 βρώσις, 2627<sup>b</sup>  
 βύσσος, 876<sup>b</sup>  
 βωμός, 106<sup>b</sup>  
  
 γάμος (LXX), 385<sup>a</sup>  
 γενεά, 1199<sup>a</sup>  
 γενέσια, 478<sup>a</sup>  
 γένεσις, 477<sup>b</sup>  
 γεννάω, 398<sup>b</sup>; 426<sup>b</sup>; 1410<sup>b</sup>; 1703<sup>a</sup>  
 γερούσια, 2719<sup>b</sup>  
 γέφυρα, 522<sup>a</sup>  
 γινώσκω, 37<sup>b</sup>; 99<sup>b</sup>; 1130<sup>a</sup>; 1698<sup>a</sup>  
 γλώσσα, 2996<sup>a</sup>  
 γλωσσόκομον, 377<sup>b</sup>  
 γνώσις, 302<sup>a</sup>; 677<sup>b</sup>; 959<sup>b</sup>; 1240<sup>a</sup>;  
 1241<sup>b</sup>; 1242<sup>b</sup>; 1245<sup>b</sup>; 2260<sup>b</sup>;  
 2702<sup>b</sup>  
 γνωστός, 37<sup>b</sup>  
 γότης, 748<sup>a</sup>; 942<sup>b</sup>; 1964<sup>b</sup>  
 γόμος, 529<sup>a</sup>  
 γράμμα, 474<sup>a</sup>; 597<sup>b</sup>  
 γραμματεὺς, 2704<sup>b</sup>; 3001<sup>a</sup>  
  
 δαιμόνιον, 689<sup>b</sup>; 827<sup>b</sup>; 829<sup>a</sup>  
 δαίμων, 827<sup>b</sup>  
 δάνειον, 814<sup>a</sup>  
 δαπανᾶω, 595<sup>a</sup>  
 δέσις, 2430<sup>a</sup>  
 δεῖ, 427<sup>b</sup>  
 δείπνον, 385<sup>a</sup>  
 δελεάζω, 426<sup>b</sup>  
 δεσπότης, 1919<sup>a</sup>  
 δευτερόπρωτος, 2634<sup>b</sup>  
 δηνᾶριον, 830<sup>a</sup>  
 διά, 395<sup>b</sup>  
 διάβολος, 35<sup>a</sup>; 64<sup>b</sup>; 957<sup>b</sup>  
 διάδημα, 762<sup>b</sup>  
 διαθήκη, 460<sup>b</sup>; 729<sup>b</sup>; 731<sup>a</sup>  
 διακονέω, 56<sup>b</sup>; 800<sup>b</sup>  
 διακονία, 56<sup>b</sup>; 800<sup>b</sup>  
 διάκονος, 800<sup>a</sup>; 3103<sup>b</sup>  
 διαλαλέω, 23<sup>a</sup>  
 διαλείπω, 586<sup>a</sup>  
 διαμερίζω, 671<sup>a</sup>  
 διάνοια, 2056<sup>a</sup>  
 διασπορά, 855<sup>a</sup>  
 διαφμίξω, 23<sup>a</sup>  
  
 διάψαλμα, 2096<sup>b</sup>; 2488<sup>b</sup>  
 διδακτικός, 1899<sup>a</sup>  
 διδασκαλία, 866<sup>b</sup>  
 διδάσκαλος, 851<sup>b</sup>  
 διδαχή, 867<sup>a</sup>  
 διδραχμα, 1649<sup>b</sup>  
 ίδωμι, 64<sup>b</sup>  
 διαιρέω (LXX), 5<sup>a</sup>  
 δικαίω, 1782<sup>b</sup>; 1784<sup>a</sup>; 1786<sup>a</sup>  
 δικαίωμα, 1782<sup>b</sup>  
 δικη (LXX), 2403<sup>a</sup>  
 διοσετής, 1781<sup>a</sup>  
 διάρθρωσις, 2545<sup>b</sup>  
 Διόσκουροι, 851<sup>a</sup>  
 διχαστασία, 1377<sup>a</sup>  
 δίψυχος, 870<sup>b</sup>  
 δόγμα, 461<sup>a</sup>; 868<sup>a</sup>  
 δοκιμάζω, 99<sup>b</sup>; 210<sup>b</sup>  
 δόξα, 146<sup>a</sup>; 849<sup>a</sup>; 991<sup>b</sup>; (LXX)  
 1236<sup>b</sup>; 1238<sup>b</sup>; 1239<sup>a</sup>  
 δουλεία, 495<sup>a</sup>  
 δοῦλος, 495<sup>a</sup>; 800<sup>a</sup>  
 δοχή, 385<sup>a</sup>  
 δράκων, 427<sup>b</sup>; 873<sup>a</sup>  
 δραχμή (LXX), 872<sup>b</sup>; 2395<sup>a</sup>  
 δύναμαι, 13<sup>b</sup>  
 δύναμις, 11<sup>a</sup>; 333<sup>a</sup>; 403<sup>a</sup>; 2063<sup>a</sup>;  
 2427<sup>b</sup>; 3057<sup>a</sup>  
 δυνάστης, 333<sup>a</sup>; 2423<sup>a</sup>  
  
 ἐγγαστρέμυθος (LXX), 690<sup>a</sup>; 944<sup>a</sup>  
 ἐγείρω, 53<sup>a</sup>; 986<sup>a</sup>; 992<sup>a</sup>  
 ἐγκαίνια, τὰ, 816<sup>b</sup>  
 ἐγκεντρίζω, 1292<sup>b</sup>  
 ἔθνος, 1215<sup>a</sup>  
 ἔθος, 769<sup>b</sup>  
 εἰδωλόθνητος, 715<sup>a</sup>  
 εἰκών, 145<sup>b</sup>; 146<sup>a</sup>; 1451<sup>b</sup>; 1454<sup>b</sup>;  
 1914<sup>b</sup>  
 εἰρήνη, 2293<sup>a</sup>  
 εἰς, 386<sup>b</sup>; 387<sup>b</sup>; 395<sup>a</sup>  
 ἐκ, 386<sup>b</sup>  
 ἑκατοντάρχης, 588<sup>a</sup>  
 ἐκκλησία, 289<sup>a</sup>; 651<sup>a</sup>; 893<sup>b</sup>; 1648<sup>b</sup>;  
 2292<sup>a</sup>  
 ἐκλέγω, 613<sup>b</sup>  
 ἐκλεκτός, 925<sup>a</sup>  
 ἐκλογή, 925<sup>b</sup>  
 ἕκστασις, 3005<sup>a</sup>  
 ἐλάτης (LXX), 533<sup>a</sup>  
 ἐλεᾶτε, 2546<sup>a</sup>  
 ἐλέγχω, 2560<sup>b</sup>  
 ἐλεημοσύνη, 101<sup>b</sup>; 425<sup>b</sup>  
 ἔλεος, 2035<sup>b</sup>  
 ἔλλην, 1295<sup>a</sup>  
 Ἑλληνιστής, 1295<sup>a</sup>  
 ἐλπὶς, 1087<sup>b</sup>  
 ἐμπορεύομαι, 533<sup>a</sup>  
 ἐν, 387<sup>a</sup>; 395<sup>a</sup>  
 ἐνθυμέομαι, 2972<sup>b</sup>  
 ἐναντός, 3126<sup>a</sup>  
 ἐνοχος, 782<sup>a</sup>; 1310<sup>a</sup>  
  
 ἐνταφιάζω, 529<sup>a</sup>  
 ἐντυγχάνω, 1484<sup>b</sup>  
 ἐξαγοράζω, 59<sup>a</sup>; 2655<sup>b</sup>  
 ἐξίστημι, 441<sup>a</sup>; 3097<sup>b</sup>  
 ἐξορκίζω, 1067<sup>b</sup>  
 ἐξουσία, 333<sup>a</sup>; 1781<sup>b</sup>; 2427<sup>b</sup>; 3057<sup>a</sup>  
 ἐξωτερικός, 179<sup>b</sup>  
 ἐπάνω, 103<sup>b</sup>  
 ἐπερώτημα, 395<sup>a</sup>  
 ἐπίγειος, 887<sup>b</sup>; 2497<sup>a</sup>  
 ἐπίγνωσις, 1816<sup>a</sup>  
 ἐπιείκεια, 668<sup>b</sup>; 1215<sup>b</sup>  
 ἐπεικής, 1215<sup>b</sup>  
 ἐπίθεσις χειρῶν, 1335<sup>a</sup>  
 ἐπίθυμέω, 1086<sup>b</sup>  
 ἐπιθυμία, 698<sup>a</sup>; 1942<sup>a</sup>  
 ἐπικαλέω, 208<sup>a</sup>  
 ἐπιλέγω, 613<sup>b</sup>  
 ἐπιούσιος, 1364<sup>b</sup>; 1921<sup>a</sup>; 3060<sup>a</sup>  
 ἐπίσκοπος, 478<sup>b</sup>; 482<sup>a</sup>; 1899<sup>a</sup>; 1902<sup>b</sup>  
 ἐπιστρέφω, 706<sup>b</sup>; 2558<sup>b</sup>  
 ἐπιστροφή, 706<sup>b</sup>  
 ἐπιτίθημι, 54<sup>b</sup>  
 ἐπιφάνεια, 981<sup>b</sup>; 2054<sup>b</sup>; 2249<sup>a</sup>; 2700<sup>b</sup>  
 ἐπόπτης, 427<sup>a</sup>  
 ἐπουράνιος, 587<sup>b</sup>; 957<sup>b</sup>; 959<sup>a</sup>; 1352<sup>b</sup>  
 ἐπωμίς (LXX), 962<sup>a</sup>  
 ἐργασία, 533<sup>a</sup>; 1153<sup>b</sup>  
 ἐρημία, 832<sup>a</sup>  
 ἔρημος, 832<sup>a</sup>  
 ἔριφος, 1249<sup>a</sup>  
 ἔρρωσο, 1098<sup>a</sup>  
 ἔσσοτρον, 1234<sup>a</sup>  
 ἔσσοτερικός, 179<sup>b</sup>; 180<sup>a</sup>  
 ἔτερος, 989<sup>a</sup>  
 ἔτος, 3126<sup>a</sup>  
 εὐαγγέλιον, 1039<sup>b</sup>; 1281<sup>a</sup>  
 εὐαγγελιστής, 1039<sup>b</sup>  
 εὐδοκέω, 99<sup>b</sup>  
 εὐθέως, 1993<sup>a</sup>  
 εὐθύς, 535<sup>b</sup>  
 εὐλαβέομαι (LXX), 341<sup>a</sup>  
 εὐλογία, 487<sup>b</sup>; 511<sup>a</sup>  
 εὐνούχος, 1037<sup>a</sup>  
 εὐπερίστατος, 441<sup>a</sup>  
 εὐπρόσδεκτος, 27<sup>b</sup>  
 εὐρακύλων, 1039<sup>b</sup>  
 εὐσεβής, 840<sup>a</sup>  
 εὐσπλαγχνος, 2402<sup>a</sup>  
 εὐσχημόνων, 816<sup>a</sup>  
 εὐτραπελία, 1624<sup>a</sup>  
 εὐχарιστία, 1924<sup>b</sup>  
 εὐώνυμος, 1334<sup>b</sup>  
 ἐχθρός, 1135<sup>b</sup>; 2537<sup>a</sup>  
  
 ζάω, 97<sup>a</sup>  
 ζηλώω, 65<sup>b</sup>  
 ζωή, 1702<sup>b</sup>; 1889<sup>a</sup>  
 ζῆλον, 73<sup>b</sup>; 418<sup>b</sup>  
  
 ἡγεμών, 2453<sup>a</sup>; 2458<sup>a</sup>  
 ἡγέομαι, 2972<sup>b</sup>

- ἦθος, 1013<sup>b</sup>  
 ἡλικία, 71<sup>a</sup>  
  
 θάνατος, 811<sup>a</sup>  
 θαύμα, 56<sup>b</sup>  
 θεατρίζω, 1179<sup>b</sup>  
 θέατρον, 1173<sup>a</sup>; 1179<sup>b</sup>  
 θεϊότης, 1269<sup>a</sup>  
 θεῖον, 1269<sup>a</sup>  
 θέλημα, 3085<sup>a</sup>  
 θέλω, 3085<sup>a</sup>  
 θεμέλιος, 1141<sup>b</sup>  
 θεοκρατία, 2965<sup>b</sup>  
 θεόπνευστος, 1473<sup>b</sup>  
 θεότης, 1269<sup>a</sup>  
 θεραπεύω, 1349<sup>a</sup>; 2394<sup>a</sup>  
 θηρίον, 418<sup>b</sup>  
 θησαυρός (LXX), 254<sup>b</sup>; 3008<sup>a</sup>  
 θλιψίς, 66<sup>a</sup>; 136<sup>a</sup>  
 θορυβέω, 57<sup>a</sup>  
 θρόμβος, 490<sup>b</sup>  
 θυματήριον, 588<sup>a</sup>  
 θυμός, 1017<sup>b</sup>; 2571<sup>a</sup>  
 θυμός, 1472<sup>b</sup>  
 θυσιαστήριον, 106<sup>b</sup>  
  
 ἰάομαι, 1349<sup>a</sup>; 2394<sup>a</sup>  
 ἰατρός, 2393<sup>b</sup>  
 ἰδέαι, 1913<sup>b</sup>  
 ἴδιος, 968<sup>a</sup>; 2745<sup>a</sup>  
 ἱερέυς, 2439<sup>a</sup>  
 ἴκτερος (LXX), 78<sup>a</sup>; 1108<sup>a</sup>  
 ἰλάσκομαι, 321<sup>b</sup>; 2654<sup>a</sup>  
 ἰλασμός, 1717<sup>a</sup>; 2467<sup>a</sup>  
 ἰλαστήριον, 242<sup>b</sup>; 2036<sup>a</sup>; (LXX) 2467<sup>a</sup>; 2617<sup>a</sup>; 2656<sup>a</sup>  
 ἰμάτιον, 876<sup>b</sup>  
 ἴσος, 75<sup>b</sup>; 968<sup>a</sup>  
 ἰσόψυχος, 2497<sup>b</sup>  
 ἰσχύς, 11<sup>a</sup>  
 ἰσχύω, 13<sup>b</sup>; 340<sup>a</sup>  
  
 καθαίρεσις, 2789<sup>a</sup>  
 καθάπτω, 41<sup>a</sup>  
 καθαρίζω, 394<sup>b</sup>  
 καθάρως, 667<sup>a</sup>  
 καθίστημι, 479<sup>a</sup>; 655<sup>a</sup>  
 καθολικός, 583<sup>a</sup>  
 καθόλου, 583<sup>a</sup>  
 καινός, 1975<sup>a</sup>; 2140<sup>b</sup>  
 κακῶς, 116<sup>b</sup>  
 κάλαμος, 2297<sup>b</sup>  
 κάμηλος, 548<sup>a</sup>  
 κανών, 554<sup>a</sup>  
 καρδία, 1350<sup>b</sup>; 1351<sup>a</sup>  
 καρδιογνώστης, 1351<sup>b</sup>  
 καρπὸς τῶν χειλέων (LXX), 546<sup>b</sup>  
 καταλλάσσω, 2635<sup>b</sup>  
 κατάλυμα, 1308<sup>b</sup>; 1433<sup>a</sup>; 1470<sup>b</sup>  
 κατάρα, 767<sup>a</sup>  
 καταργέω, 15<sup>a</sup>  
 κατατομή, 696<sup>b</sup>  
  
 κατήγορος, 35<sup>a</sup>  
 κατήγωρ, 2693<sup>b</sup>  
 κατηγέω, 1991<sup>b</sup>  
 κατηγίζω, 582<sup>b</sup>  
 κατοπτρίζω, 427<sup>a</sup>  
 κάτοπτρον, 427<sup>a</sup>  
 καυχάομαι, 1239<sup>b</sup>  
 καύχημα, 1235<sup>b</sup>; 1239<sup>b</sup>  
 κέντρον, 1248<sup>b</sup>; (LXX) 2403<sup>a</sup>  
 κεντυρίων, 588<sup>a</sup>  
 κένωσις, 1792<sup>a</sup>  
 κεράμιον, 2401<sup>b</sup>  
 κεράτιον, 1443<sup>a</sup>  
 κήσος, 3010<sup>b</sup>  
 κήρυξ, 2433<sup>a</sup>  
 κήτος, 3082<sup>b</sup>  
 κιβωτός, 242<sup>a</sup>; 605<sup>a</sup>; 1883<sup>b</sup>  
 κιθάρα, 660<sup>a</sup>; 2098<sup>a</sup>  
 κινύρα, 660<sup>a</sup>; 2097<sup>b</sup>  
 κλάδος, 514<sup>a</sup>  
 κλάσμα, 1144<sup>a</sup>  
 κλήμα, 514<sup>a</sup>  
 κλήσις, 545<sup>b</sup>  
 κλίση, 422<sup>b</sup>  
 κοδράντης, 1098<sup>b</sup>; 2067<sup>b</sup>  
 κοινός, 688<sup>a</sup>; 690<sup>b</sup>  
 κοινωνία, 652<sup>a</sup>; 688<sup>b</sup>; 705<sup>b</sup>; 1703<sup>b</sup>; 1924<sup>b</sup>; 1927<sup>b</sup>  
 κοινωνικός, 688<sup>b</sup>; 705<sup>b</sup>  
 κοίτη, 422<sup>b</sup>; 591<sup>b</sup>  
 κόλασις, 2571<sup>b</sup>  
 κολλούριον, 1070<sup>a</sup>  
 κολλυβιστής, 594<sup>a</sup>  
 κόλπος, 22<sup>b</sup>; 416<sup>b</sup>; 743<sup>b</sup>  
 κόρη, 210<sup>a</sup>  
 κοσμέω, 61<sup>b</sup>  
 κόσμος, 980<sup>b</sup>; 1704<sup>a</sup>; 1782<sup>b</sup>; 3108<sup>b</sup>  
 κοστωδία, 1308<sup>a</sup>  
 κόφινος, 413<sup>b</sup>  
 κράββατος, 422<sup>b</sup>  
 κράσπεδον, 504<sup>a</sup>; 1374<sup>a</sup>; 1907<sup>a</sup>  
 κρέας, 1118<sup>b</sup>  
 κρίμα, 781<sup>a</sup>  
 κρίσταλλος, 764<sup>b</sup>  
 κτήνος, 419<sup>a</sup>; 583<sup>b</sup>  
 κτίσις, 738<sup>a</sup>  
 κτίσμα, 740<sup>b</sup>  
 κτιστής, 740<sup>a</sup>  
 κυλλικός, 766<sup>b</sup>  
 κυλλός, 1968<sup>a</sup>  
 κυρία, 773<sup>b</sup>; 925<sup>a</sup>  
 κυριακός, 1910<sup>a</sup>; 1919<sup>a</sup>  
 Κύριος, 1254<sup>b</sup>; (LXX) 1268<sup>a</sup>; 1919<sup>a</sup>; 2806<sup>a</sup>  
 κυριότης, 869<sup>a</sup>  
 κωνωπεῖον, 566<sup>b</sup>  
  
 λακτίζω, 1797<sup>a</sup>  
 λαμβάνω, 27<sup>b</sup>  
 λαμπάς, 1825<sup>a</sup>  
 λαός (LXX), 1215<sup>a</sup>  
 λαπιστής (LXX), 348<sup>b</sup>  
  
 λειτουργία, 1828<sup>b</sup>; 2742<sup>b</sup>  
 λεκάνη (LXX), 511<sup>b</sup>  
 λεπτόν, 1657<sup>a</sup>; 2067<sup>b</sup>  
 λιβανωτός, 588<sup>a</sup>  
 λιμός, 2348<sup>b</sup>  
 λογία, 674<sup>a</sup>  
 λογιζομαι, 1462<sup>b</sup>  
 λόγιον, 1884<sup>b</sup>; 1910<sup>a</sup>  
 λόγος, 1884<sup>b</sup>; 1911<sup>b</sup>; 3105<sup>a</sup>  
 λόγος ἐνδιάθετος, 1913<sup>b</sup>  
 λόγος προφορικός, 1913<sup>b</sup>  
 λόγχη, 252<sup>b</sup>  
 λοιμός, 2348<sup>b</sup>  
 λουτρόν, 394<sup>b</sup>; 398<sup>b</sup>; 1844<sup>a</sup>  
 λούω, 14<sup>a</sup>; 394<sup>b</sup>; 3073<sup>a</sup>  
 λύτρον, 2022<sup>a</sup>; 2530<sup>b</sup>; (LXX) 2531<sup>a</sup>  
 λυχρία, 552<sup>b</sup>  
 λύχνος, 552<sup>b</sup>; 1825<sup>a</sup>; 1892<sup>a</sup>  
 λύω, 24<sup>a</sup>; 1716<sup>b</sup>  
  
 μαγεύω, 2795<sup>b</sup>  
 μαγία, 2795<sup>b</sup>  
 μάγος, 404<sup>b</sup>  
 μαθητής, 851<sup>b</sup>  
 μάντις, 860<sup>b</sup>; 863<sup>a</sup>; 942<sup>b</sup>  
 μάστιξ, 2402<sup>b</sup>  
 μάχαιρα, 251<sup>b</sup>  
 μεγαλαυχέω, 513<sup>a</sup>  
 μεγιστάνες, 1919<sup>a</sup>  
 μέθη, 880<sup>b</sup>  
 μέλαν, 1469<sup>a</sup>  
 μέλει, 578<sup>a</sup>  
 μέλλω, 18<sup>a</sup>  
 μένω, 9<sup>a</sup>; 1703<sup>b</sup>  
 μέριμμα, 577<sup>b</sup>  
 μεσίτης, 616<sup>b</sup>; 2018<sup>b</sup>  
 μεταβάλλω, 594<sup>a</sup>  
 μετάθεσις, 3007<sup>a</sup>  
 μεταμέλομαι, 2558<sup>b</sup>  
 μετανοέω, 2558<sup>b</sup>  
 μετασχηματίζω, 594<sup>a</sup>  
 μετοικεσία (LXX), 569<sup>b</sup>  
 μη γένοιτο (LXX), 1097<sup>b</sup>; 1127<sup>a</sup>  
 μισθωτός, 1395<sup>a</sup>  
 μονή, 9<sup>a</sup>; 1983<sup>b</sup>  
 μονογενής, 1113<sup>b</sup>; 2196<sup>a</sup>  
 μορφή, 1098<sup>b</sup>  
 μύθος, 943<sup>b</sup>; 1085<sup>a</sup>  
 μυστήριον, 1924<sup>b</sup>; 2104<sup>a</sup>; 2105<sup>b</sup>; 2636<sup>b</sup>  
 μαρός, 1125<sup>a</sup>; 2523<sup>a</sup>  
  
 νέος, 1975<sup>a</sup>; 2140<sup>b</sup>  
 νεύμα, 421<sup>b</sup>  
 νεωκόρος, 601<sup>a</sup>  
 νήπιος, 348<sup>b</sup>  
 νηστεία, 1099<sup>a</sup>  
 νιπτήρ, 412<sup>b</sup>  
 νίπτω, 14<sup>a</sup>; 3073<sup>a</sup>  
 νόθος, 413<sup>b</sup>  
 νομίζω, 2972<sup>b</sup>  
 νομικός, 1859<sup>a</sup>; 2704<sup>b</sup>



- νομοδιδάσκαλος, 2704<sup>b</sup>  
 νομοθέτης, 1858<sup>b</sup>  
 νόμος, 1844<sup>b</sup>  
 νόσος, 854<sup>a</sup>  
 νοῦς, 2056<sup>a</sup>; 2721<sup>a</sup>; 3094<sup>b</sup>  
 νυμφών, 522<sup>a</sup>
- ἤγηταινω, 2399<sup>b</sup>
- ὄγκος, 529<sup>a</sup>  
 οἰκοδεσπότης, 1438<sup>b</sup>  
 οἰκονόμος, 152<sup>a</sup>; 591<sup>b</sup>  
 οἰκουμένη, 887<sup>a</sup>; 1353<sup>b</sup>; 2600<sup>a</sup>; 3109<sup>a</sup>  
 ὄλεθρος, 991<sup>a</sup>  
 ὄμιλία, 706<sup>a</sup>  
 ὄμοθυμαδόν, 33<sup>b</sup>  
 ὁμοίωμα, 146<sup>a</sup>  
 ὁμοίωσις, 145<sup>b</sup>; 146<sup>a</sup>  
 ὁμολογία, 699<sup>a</sup>  
 δυναρ, 874<sup>a</sup>  
 ὀπή, 585<sup>b</sup>  
 ὀργή, 2571<sup>a</sup>  
 ὀρκίζω, 56<sup>a</sup>  
 ὀρφανός, 679<sup>a</sup>; 1101<sup>a</sup>  
 ὀστρακον, 2202<sup>b</sup>  
 ὀφειλή, 435<sup>b</sup>; 814<sup>a</sup>; 883<sup>b</sup>  
 ὀφειλημα, 1309<sup>a</sup>  
 ὄφιος, 427<sup>b</sup>  
 ὀχύρωμα, 1137<sup>a</sup>; 1140<sup>b</sup>
- πάθημα, 1158<sup>b</sup>  
 πάθος, 1472<sup>b</sup>  
 παιδαγωγός, 1020<sup>a</sup>; 1783<sup>a</sup>; 2702<sup>b</sup>  
 παιδεία, 598<sup>b</sup>; 852<sup>a</sup>; 2571<sup>b</sup>  
 παιδίον, 606<sup>b</sup>; 781<sup>a</sup>  
 παιδίσκη, 495<sup>a</sup>; 781<sup>a</sup>  
 παῖς, 512<sup>b</sup>  
 πάλαι, 1790<sup>b</sup>  
 παλιγενεσία, 1354<sup>a</sup>; 2503<sup>a</sup>; 2546<sup>b</sup>; 2562<sup>a</sup>  
 πανδοχεῖον, 1470<sup>b</sup>  
 πανήγυρις, 289<sup>a</sup>  
 πανουργία, 734<sup>a</sup>  
 πανούργος, 734<sup>a</sup>  
 παντοκράτωρ, 100<sup>a</sup>; 1267<sup>a</sup>; 2188<sup>b</sup>  
 παράβασις, 2798<sup>b</sup>  
 παραβολή, 2469<sup>b</sup>  
 παραγγελία, 595<sup>a</sup>  
 παράδεισος, 152<sup>a</sup>; 1174<sup>a</sup>; 2248<sup>b</sup>  
 παραδίδωμι, 454<sup>b</sup>  
 παραθήκη, 830<sup>a</sup>  
 παρακαλέω, 678<sup>b</sup>  
 παράκλησις, 704<sup>a</sup>; 1051<sup>b</sup>  
 παράκλητος, 65<sup>a</sup>; 679<sup>a</sup>; 1488<sup>a</sup>; 2245<sup>a</sup>  
 παρακλητήτωρ, 2245<sup>a</sup>  
 παραλλαγή, 302<sup>b</sup>  
 παρασκευή, 798<sup>b</sup>; 2437<sup>a</sup>; 2982<sup>a</sup>  
 παρατίθημι, 680<sup>a</sup>  
 παραχρήμα, 1993<sup>a</sup>  
 πάρεσις, 1132<sup>b</sup>; 2557<sup>b</sup>  
 πάροικος, 1128<sup>a</sup>; 1828<sup>b</sup>; 2467<sup>b</sup>  
 παροιμία, 1170<sup>a</sup>; 2469<sup>b</sup>
- πάροις, 514<sup>b</sup>  
 παρουσία, 1657<sup>a</sup>; 2054<sup>b</sup>; 2249<sup>a</sup>; 2438<sup>a</sup>  
 παρρησία, 494<sup>b</sup>  
 παστοφορίον(LXX), 2747<sup>a</sup>  
 πάσχα, 889<sup>a</sup>; 2256<sup>a</sup>  
 πατριά, 1094<sup>b</sup>; 1894<sup>a</sup>  
 πείθω, 2348<sup>a</sup>  
 πειράζω, 288<sup>b</sup>  
 πένης, 2421<sup>a</sup>; 2427<sup>a</sup>  
 πεντηκοστή, 2318<sup>a</sup>  
 πέποιθεις, 700<sup>a</sup>  
 περιβόλαιον, 733<sup>a</sup>  
 περίεργος, 533<sup>a</sup>; 767<sup>a</sup>  
 περικεφαλαία, 251<sup>b</sup>; 253<sup>b</sup>  
 περιούσιος, 2294<sup>b</sup>  
 περιποίησις, 2294<sup>b</sup>  
 περισσίς, 17<sup>b</sup>; 64<sup>b</sup>  
 περιψήμα, 2180<sup>b</sup>  
 πέτασος, 878<sup>b</sup>  
 πέτρα, 1648<sup>b</sup>; 1795<sup>b</sup>  
 πέτρος, 1648<sup>b</sup>; 1795<sup>b</sup>  
 πηλίκος, 1070<sup>b</sup>  
 πιμπρημι, 41<sup>a</sup>  
 πιστεύω, 432<sup>a</sup>  
 πιστις, 1087<sup>b</sup>; 1090<sup>a</sup>  
 πιστός, 958<sup>a</sup>; 1090<sup>a</sup>  
 πιστός ὁ λόγος, 1091<sup>a</sup>  
 πίτυρα (LXX), 13<sup>b</sup>  
 πλανήτης, 308<sup>b</sup>  
 πλεονάζω, 17<sup>b</sup>  
 πλεονεκτέω, 64<sup>b</sup>  
 πλεονεξία, 733<sup>b</sup>; 1069<sup>a</sup>  
 πληγή, 2402<sup>b</sup>  
 πληρώω, 2461<sup>b</sup>  
 πλήρωμα, 677<sup>b</sup>; 960<sup>b</sup>; 1148<sup>b</sup>; 1244<sup>a</sup>; 1245<sup>a</sup>; 2275<sup>b</sup>  
 πνεῦμα, 398<sup>b</sup>; 399<sup>b</sup>; 1406<sup>b</sup>; 2121<sup>b</sup>; 2721<sup>a</sup>; 3094<sup>b</sup>  
 πνευματικός, 989<sup>a</sup>; 2721<sup>a</sup>  
 πνοή ζωής (LXX), 2495<sup>a</sup>  
 ποιέω, 990<sup>b</sup>  
 ποιητής, 2410<sup>a</sup>  
 ποικίλος, 860<sup>a</sup>  
 ποιμήν, 654<sup>b</sup>  
 ποιμνη, 584<sup>a</sup>  
 ποίμνιον, 584<sup>a</sup>  
 ποινή, 2697<sup>a</sup>  
 πόλις, 662<sup>a</sup>  
 πολιτάρχης, 665<sup>b</sup>  
 πολιτεία, 688<sup>b</sup>  
 πολιτευμα, 661<sup>a</sup>  
 πολίτης, 661<sup>a</sup>  
 ποιηρός, 1921<sup>a</sup>; 2805<sup>a</sup>  
 πορνεία, 1339<sup>b</sup>  
 πόρπη, 526<sup>b</sup>  
 πορφύρα, 884<sup>a</sup>  
 ποτήριον, 487<sup>b</sup>; 766<sup>a</sup>; 1924<sup>b</sup>  
 πῶτος, 580<sup>a</sup>  
 πραιτώριον, 1777<sup>b</sup>; 2428<sup>b</sup>  
 πράξις, 39<sup>a</sup>; 817<sup>a</sup>  
 πρᾶος, 2027<sup>a</sup>  
 πράσσω, 990<sup>b</sup>
- πρεσβεία, 115<sup>a</sup>  
 πρεσβεύω, 115<sup>a</sup>  
 πρεσβύτερος, 479<sup>a</sup>; 654<sup>b</sup>; 924<sup>a</sup>; 1828<sup>b</sup>; 2437<sup>b</sup>  
 πρεσβύτερος, 71<sup>a</sup>  
 πρίνος (LXX), 1405<sup>a</sup>  
 προγινώσκω, 1128<sup>a</sup>; 1130<sup>a</sup>  
 πρόγνωσις, 1128<sup>a</sup>; 2435<sup>a</sup>  
 πρόδρομος, 1131<sup>a</sup>  
 πρόθεσις, 2435<sup>a</sup>; 2510<sup>a</sup>; 2767<sup>a</sup>  
 πρόνοια, 2476<sup>b</sup>  
 προδρισιμός, 2435<sup>a</sup>  
 προσαγωγή, 27<sup>b</sup>  
 προσανατίθημι, 699<sup>a</sup>  
 προσδέχομαι, 1026<sup>b</sup>  
 προσευχή, 2469<sup>b</sup>  
 προσήλυτος, 2467<sup>b</sup>  
 προσκεφάλαιον, 769<sup>a</sup>; 2776<sup>b</sup>  
 προσκυνέω, 60<sup>b</sup>; 61<sup>a</sup>  
 προσφορά, 1923<sup>b</sup>  
 πρόσωπον, 2337<sup>a</sup>  
 προφήτης, 1408<sup>a</sup>; 2464<sup>a</sup>  
 προφητεία, 2464<sup>a</sup>  
 προφητεύω, 2464<sup>a</sup>  
 πρωτοκαθεδρία, 606<sup>b</sup>  
 πρωτοκλισία, 722<sup>a</sup>  
 πρωτοτόκια, 478<sup>a</sup>; 2452<sup>b</sup>  
 πρωτότοκος, 519<sup>a</sup>; 676<sup>b</sup>; 1113<sup>a</sup>; 1829<sup>a</sup>; 2196<sup>a</sup>  
 πτερύγιον, 2400<sup>a</sup>  
 πτώμα, 576<sup>b</sup>; 722<sup>b</sup>  
 πτωχός, 426<sup>a</sup>; 2421<sup>a</sup>; 2427<sup>a</sup>  
 πυγμή, 14<sup>b</sup>  
 πυλών, 1175<sup>b</sup>  
 πυρετός, 490<sup>b</sup>; (LXX) 1108<sup>a</sup>  
 πυρώω, 532<sup>a</sup>
- ῥαβδοῦχος, 45<sup>a</sup>; 2732<sup>b</sup>  
 ῥακά, 2523<sup>a</sup>  
 ῥαντίζω, 385<sup>b</sup>; 386<sup>a</sup>; 394<sup>b</sup>  
 ῥήμα, 3105<sup>a</sup>  
 ῥομφαία, 252<sup>b</sup>
- ῥάββατον, 2620<sup>b</sup>; 2982<sup>a</sup>  
 ῥαββάτον ὁδός, 2634<sup>a</sup>  
 ῥαμβύκη, 2099<sup>a</sup>  
 ῥανδάλιον, 2779<sup>b</sup>  
 ῥανίς, 2407<sup>b</sup>  
 ῥαργάνη, 413<sup>b</sup>  
 ῥαρκικός, 580<sup>a</sup>; 989<sup>a</sup>; 1119<sup>a</sup>; 2721<sup>a</sup>  
 ῥάρκινος, 580<sup>a</sup>; 1119<sup>a</sup>  
 ῥάρξ, 492<sup>b</sup>; 580<sup>a</sup>; 1118<sup>b</sup>  
 ῥεληνιάζομαι, 1941<sup>b</sup>; 1961<sup>a</sup>  
 ῥεμνότης, 1294<sup>a</sup>  
 ῥημίον, 2063<sup>a</sup>  
 ῥιαγών, 600<sup>a</sup>  
 ῥικάριοι, 288<sup>a</sup>  
 ῥίκερα, 879<sup>b</sup>  
 ῥκάνδαλον, 1441<sup>b</sup>  
 ῥκῆνος, 2497<sup>a</sup>  
 ῥκνίφες (LXX), 1240<sup>a</sup>  
 ῥκλόψ, 760<sup>b</sup>; 2277<sup>b</sup>

σορός, 472<sup>b</sup>  
 σουδάριον, 210<sup>b</sup>; 878<sup>b</sup>  
 σπείρα, 258<sup>a</sup>; 382<sup>b</sup>; 588<sup>a</sup>; 1669<sup>a</sup>  
 σπεκουλάτωρ, 1051<sup>b</sup>; 1308<sup>a</sup>  
 σπερματικός, 1917<sup>a</sup>  
 σπερμολόγος, 348<sup>b</sup>; 2275<sup>a</sup>  
 σπῆλαιον, 585<sup>b</sup>  
 σπλαγχνίζομαι, 695<sup>a</sup>  
 σπλάγχχον, 511<sup>a</sup>; 695<sup>a</sup>  
 σπουδή, 578<sup>a</sup>  
 στατήρ, 1649<sup>b</sup>; 2394<sup>b</sup>  
 σταυρός, 760<sup>b</sup>; 2652<sup>a</sup>  
 στέφανος (LXX), 315<sup>b</sup>  
 στέφανος, 762<sup>b</sup>  
 στήθος, 517<sup>b</sup>  
 στιβάς, 514<sup>a</sup>  
 στίγμα, 2277<sup>b</sup>  
 στίλβω, 1234<sup>b</sup>  
 στοιχείον, 927<sup>b</sup>; 2455<sup>a</sup>; 2624<sup>b</sup>  
 στοχάζω, 88<sup>b</sup>  
 στρατηγός, 45<sup>a</sup>; 569<sup>b</sup>  
 στρατοπεδάρχης, 258<sup>b</sup>; 569<sup>b</sup>; 1308<sup>a</sup>  
 συμβούλιον, 723<sup>b</sup>  
 σύμβουλος, 723<sup>b</sup>  
 συμπληρώω, 2318<sup>b</sup>  
 σύμφυτος, 2290<sup>b</sup>  
 συμφωνέω, 75<sup>b</sup>  
 σύμψυχος, 2497<sup>b</sup>  
 συναγωγή, 893<sup>b</sup>  
 συνέδριον, 723<sup>b</sup>; 2688<sup>b</sup>; 2719<sup>b</sup>  
 συνειδήσις, 701<sup>b</sup>  
 σύνεισις, 2056<sup>b</sup>  
 συγκυρία, 593<sup>b</sup>  
 συνοχή, 136<sup>a</sup>  
 σύσσωμος, 492<sup>a</sup>  
 σφραγίς, 2708<sup>a</sup>  
 σφυδρόν, 136<sup>a</sup>  
 σφυρίς, 413<sup>b</sup>  
 σχῆμα, 1098<sup>b</sup>  
 σχίσμα, 2702<sup>a</sup>  
 σῶμα, 492<sup>a</sup>; 493<sup>b</sup>; 989<sup>a</sup>; 2056<sup>a</sup>; 2275<sup>a</sup>  
 σωτήρ, 2700<sup>a</sup>  
 σωτηρία, 1786<sup>a</sup>; 2320<sup>b</sup>  
 σωφροσύνη, 1304<sup>a</sup>  
 ταμ(ε)ίον, 669<sup>b</sup>  
 ταπεινός, 1439<sup>b</sup>

ταπεινοφροσύνη, 1439<sup>b</sup>  
 ταπεινώω, 3<sup>b</sup>  
 τάσσω, 55<sup>a</sup>  
 τέκνον, 607<sup>a</sup>; 608<sup>a</sup>; 1703<sup>a</sup>  
 τελειώω, 2686<sup>a</sup>  
 τελειωτής, 1111<sup>b</sup>  
 τέλος, 3010<sup>b</sup>  
 τέρας, 2063<sup>a</sup>  
 τετράδιον, 2513<sup>a</sup>  
 τιμωρία, 2571<sup>b</sup>  
 τόκος, 383<sup>b</sup>; 1488<sup>b</sup>; 3042<sup>a</sup>  
 τράπεζα, 383<sup>b</sup>  
 τραπέζιτης, 383<sup>b</sup>; 384<sup>a</sup>  
 τραχηλίζω, 2196<sup>b</sup>  
 τροπή, 302<sup>b</sup>  
 τρόχος τῆς γενέσεως, 725<sup>a</sup>; 3083<sup>a</sup>  
 τυμπανίζω, 2704<sup>b</sup>  
 τύπος, 396<sup>a</sup>  
 τυφλός, 487<sup>b</sup>  
 τύχη (LXX), 593<sup>a</sup>  
 ἄλος, 1233<sup>a</sup>  
 ἄβρις, 1304<sup>a</sup>  
 υἰοθεσία, 58<sup>a</sup>; 2556<sup>b</sup>  
 υἰός, 608<sup>a</sup>  
 ἄμμος, 1445<sup>a</sup>  
 ὑπακοή, 2175<sup>b</sup>  
 ὑπεροχή, 333<sup>a</sup>  
 ὑπέρετης, 800<sup>a</sup>; 1986<sup>b</sup>; 2689<sup>b</sup>  
 ὑπερψύω, 614<sup>b</sup>  
 ὑπόδημα, 2779<sup>b</sup>  
 ὑπόκρισις, 721<sup>b</sup>; 1445<sup>a</sup>  
 ὑποκριτής, 1445<sup>b</sup>  
 ὑπομονή, 1918<sup>b</sup>  
 ὑπόστασις, 2337<sup>a</sup>  
 φαινόλης, 669<sup>b</sup>  
 φανερώνω, 2581<sup>b</sup>  
 φάντασία, 101<sup>a</sup>  
 φαρμακεία, 1964<sup>b</sup>  
 φέρω, 1823<sup>a</sup>  
 φημί, 66<sup>a</sup>  
 φθόγγος, 1894<sup>a</sup>  
 φιλαδελφία, 525<sup>b</sup>  
 φιλαντος, 1003<sup>a</sup>  
 φιλέω, 432<sup>b</sup>; 1932<sup>a</sup>

φίλημα, 1814<sup>a</sup>  
 φιλοσοφία, 2383<sup>a</sup>  
 φόρος, 3010<sup>b</sup>  
 φορτίον, 528<sup>b</sup>  
 φρέαρ, 424<sup>a</sup>  
 φρονέω, 2972<sup>b</sup>  
 φυλακτήριον, 126<sup>b</sup>; 2392<sup>b</sup>  
 φυλακή (LXX), 538<sup>a</sup>; 2982<sup>a</sup>  
 φυλάρχης, 2393<sup>b</sup>  
 φυλάσσω, 128<sup>a</sup>  
 φῶς, 1892<sup>a</sup>  
 φωτίζω, 1449<sup>a</sup>  
 χαίρω, 967<sup>a</sup>; 1291<sup>b</sup>; 1719<sup>a</sup>  
 χαρακτήρ, 1069<sup>a</sup>; 1451<sup>a</sup>; (LXX)  
 1468<sup>a</sup>  
 χάραξ, 383<sup>a</sup>; 2789<sup>a</sup>  
 χαρίζομαι, 1133<sup>a</sup>  
 χάρις, 27<sup>b</sup>; 1290<sup>a</sup>; 2035<sup>b</sup>  
 χάρισμα, 1228<sup>b</sup>; 1349<sup>b</sup>  
 χάσμα, 1310<sup>b</sup>  
 χειροτονέω, 479<sup>a</sup>; 613<sup>b</sup>; 655<sup>a</sup>;  
 2199<sup>b</sup>  
 χιλιάρχος, 257<sup>a</sup>; 258<sup>b</sup>; 569<sup>b</sup>  
 χιτών, 876<sup>a</sup>  
 χοϊκός, 989<sup>b</sup>  
 χρηματισμός, 2581<sup>b</sup>  
 χριστιανισμός, 622<sup>b</sup>  
 χριστιανός, 621<sup>b</sup>  
 Χριστός, 1411<sup>a</sup>  
 χρίω, 138<sup>a</sup>  
 χρόνος, 629<sup>b</sup>  
 χυλός, 1968<sup>a</sup>  
 ψαλτήριον, 2098<sup>b</sup>  
 ψευδόχριστος, 628<sup>b</sup>  
 ψιλή ποικίλη (LXX), 375<sup>b</sup>  
 ψυχή, 208<sup>b</sup>; 1351<sup>a</sup>; 1889<sup>a</sup>; 2721<sup>a</sup>;  
 3094<sup>a</sup>  
 ψυχικός, 492<sup>b</sup>; 989<sup>a</sup>; 1974<sup>a</sup>; 2121<sup>b</sup>;  
 2721<sup>a</sup>  
 ὠνόμοι, 533<sup>a</sup>  
 ὠρα, 1434<sup>a</sup>  
 ὠρισμένος, 834<sup>a</sup>

## INDEX OF ILLUSTRATIONS

<p>ABANA RIVER . . . . . ii. 779</p> <p>ABRAHAM'S OAK . . . . . ii. 1366</p> <p>ABSALOM'S PILLAR AND TOMBS OF ST. JAMES AND ZACHARIAS (Full Page) . . . . . i. 234</p> <p>ABSALOM'S TOMB . . . . . i. 24</p> <p>ACROPOLIS AND AREOPAGUS, ATHENS . . . . . i. 319</p> <p>ADDER . . . . . iv. 2737</p> <p>AGRICULTURE—</p> <ol style="list-style-type: none"> <li>1. Bringing Home the Barley Harvest . . . . . i. 405</li> <li>2. Egyptian Threshing-floor . . . . . v. 2976</li> <li>3. Field of Boaz . . . . . i. 491</li> <li>4. Going to Market . . . . . i. 534</li> <li>5. Going to Market . . . . . iii. 1996</li> <li>6. Implements of Agriculture . . . . . i. 75</li> <li>7. Market-place at Jaffa . . . . . i. 533</li> <li>8. Modern Syrian Wine Press (Full Page) . . . . . v. 3086</li> <li>9. Olive Press at Banias near Dan (Full Page) . . . . . iv. 2184</li> <li>10. Plowing near Nazareth . . . . . iv. 2221</li> <li>11. Plowing in Syria with Yoke of Oxen . . . . . v. 3127</li> <li>12. Priest-king and God of Cultivation . . . . . iii. 1399</li> <li>13. Primitiv Plowing . . . . . i. 76</li> <li>14. Reaping and Binding Sheaves . . . . . iv. 2534</li> <li>15. Sheep at Dothan (Full Page) . . . . . iii. 1738</li> <li>16. Shepherd of Bethany . . . . . ii. 876</li> <li>17. Shepherd and Sheep . . . . . iv. 2763</li> <li>18. The Shepherd's Field and Field of Boaz . . . . . i. 450</li> <li>19. Syrian Plow, Yoke and Pick . . . . . iv. 2409</li> <li>20. Threshing Instrument with Sharp Teeth . . . . . i. 76</li> <li>21. Threshing with Oxen . . . . . i. 77</li> <li>22. Yoke of Ancient Plow . . . . . v. 3126</li> </ol> <p>AHURA MAZDA . . . . . iv. 2332</p> <p>AIN JIDY, LOOKING SOUTH . . . . . ii. 808</p> <p>ALABASTER BOXES . . . . . i. 512</p> <p>ALGUM TREE . . . . . i. 96</p> <p>ALMOND TREE . . . . . i. 100</p> <p>ALOES . . . . . i. 103</p> <p>ALPHABET—</p> <ol style="list-style-type: none"> <li>1. The Paestos Disk, Face A . . . . . i. 104</li> <li>2. Primitive Alphabets (Insert) . . . . . i. 104</li> <li>3. Primitive Signs Like A . . . . . i. 104</li> <li>4. Table Showing Script of Semitic Lan- guages . . . . . iv. 2314</li> </ol> <p>ALTAR OF BURNT OFFERING AND ALTAR OF INCENSE . . . . . i. 107</p> <p>ALTARS—</p> <ol style="list-style-type: none"> <li>1. Altar of Burnt Offering and Altar of Incense . . . . . i. 107</li> <li>2. Cairn Altar . . . . . i. 107</li> <li>3. Fire Altars . . . . . iv. 2334</li> <li>4. Incense Altars of Sandstone Found in the Rock Shrine at Sinai . . . . . i. 109</li> </ol>	<ol style="list-style-type: none"> <li>5. Rock Altar from Taanach . . . . . i. 109</li> <li>6. Rock Altar at Tell el-Mutasellim— Megiddo (Full Page) . . . . . iii. 1390</li> <li>7. Stone Altar of Gezer . . . . . i. 108</li> </ol> <p>AMICUS RUFUS . . . . . iii. 2079</p> <p>ANATHOTH, JEREMIAH'S BIRTHPLACE (Full Page) . . . . . iii. 1588</p> <p>ANCIENT AQUEDUCT AT SMYRNA . . . . . iv. 2818</p> <p>ANCIENT ASIATIC CROWNS . . . . . ii. 762</p> <p>ANCIENT EGYPTIAN BASKETS . . . . . i. 413</p> <p>ANCIENT EGYPTIAN HINGES . . . . . iii. 1393</p> <p>ANCIENT EGYPTIAN PAINTINGS ON CLOTH (Full Page) . . . . . ii. 914</p> <p>ANCIENT EGYPTIAN TEMPLE—PHILAE (Full Page) . . . . . ii. 1034</p> <p>ANCIENT HORNS AND CURVED TRUMPETS . . . . . v. 3025</p> <p>ANCIENT MANUSCRIPT ON PAPYRUS. (In- sert) . . . . . iii. 2238</p> <p>ANCIENT OIL PRESSES . . . . . iv. 2182</p> <p>ANCIENT PAINTING OF AN EGYPTIAN PRIN- CESS (Full Page) . . . . . iv. 2360</p> <p>ANCIENT POTTERY (Full Page) . . . . . iv. 2424</p> <p>ANCIENT SEALS FROM ORIGINALS IN THE BRITISH MUSEUM . . . . . iv. 2708</p> <p>ANIMALS—</p> <ol style="list-style-type: none"> <li>1. Adder . . . . . iv. 2737</li> <li>2. Antelope . . . . . i. 144</li> <li>3. Asp . . . . . i. 286</li> <li>4. Asses at a Mill . . . . . i. 287</li> <li>5. Asshur-bani-pal Hunting . . . . . i. 294</li> <li>6. Assyrian Lion Hunt . . . . . iii. 1441</li> <li>7. Bas-relief of Lion Hunt . . . . . iv. 2150</li> <li>8. Bats' Ears . . . . . i. 414</li> <li>9. Bit and Bridle . . . . . i. 482</li> <li>10. Broad-tailed Sheep . . . . . iv. 2757</li> <li>11. Bronze Goat Head from Tello . . . . . i. 359</li> <li>12. Camels at the Sea of Galilee . . . . . i. 548</li> <li>13. Cattle . . . . . i. 584</li> <li>14. Chameleon . . . . . i. 592</li> <li>15. Chamois: Persian Wild Goat or Pasang . . . . . i. 592</li> <li>16. Elephant's Tusks Brought to Thoth- mes III . . . . . iii. 1544</li> <li>17. Fighting with Wild Beasts . . . . . ii. 1172</li> <li>18. Fox . . . . . ii. 1144</li> <li>19. Gazelle . . . . . ii. 1179</li> <li>20. Gazelle . . . . . iv. 2597</li> <li>21. Gecko . . . . . iii. 1906</li> <li>22. Group of Conies . . . . . ii. 698</li> <li>23. Hittite Lion, Boghaz-keuy; at the "Lion Gate" . . . . . i. 278</li> <li>24. Hooded Snake . . . . . i. 55</li> <li>25. Hunting Deer in an Enclosed Field . . . . . iii. 1441</li> <li>26. Jackal . . . . . iii. 1548</li> <li>27. Leopard . . . . . iii. 1866</li> </ol>
---	--

28. Lion . . . . . iii. 1895  
 29. Monkey from the Praenestine Mo-  
     saic . . . . . i. 160  
 30. Pariah Dog at Beirut . . . . . ii. 867  
 31. Plowing in Syria with Yoke of Oxen v. 3127  
 32. Sheep at Dothan (Full Page) . . . . . iii. 1738  
 33. Shells of *Murex trunculus* at Sidon . iv. 2510  
 34. Shepherd and Sheep . . . . . iv. 2763  
 35. Syrian Bear . . . . . i. 417  
 36. Threshing with Oxen . . . . . i. 77  
 37. Wild Goat of Sinai . . . . . ii. 1249  
 38. Wolf . . . . . v. 3099  
 39. Young Camels Grazing . . . . . i. 547  
 ANISE . . . . . i. 136  
 ANTELOPE . . . . . i. 144  
 ANTI-LEBANON: SOUK-WADY-BARRADA . . . iii. 1862  
 APHRODITE . . . . . ii. 1298  
 APPROACHES TO A CITY . . . . . i. 663  
 ARAB MEAL . . . . . iii. 2014  
 ARABS—  
   1. Arab Meal . . . . . iii. 2014  
   2. Arab Tent . . . . . v. 2948  
   3. Arab Women Preparing Bread . . . . i. 516  
   4. Bedawin of Moab . . . . . iii. 2070  
   5. Modern Arab Marriage Procession . . iii. 1997  
   6. Modern Arabs . . . . . i. 215  
   7. Modern Arabs Encamped in the  
     Valley of Achor . . . . . i. 214  
   8. Modern Arab Village . . . . . iii. 1437  
   9. Showing "Shed" of Arab Loom . . . v. 3078  
 ARAB TENT . . . . . v. 2948  
 ARAB WOMEN PREPARING BREAD . . . . . i. 516  
 ARAMAIC, GREEK AND LATIN WRITING IN  
 COMMON USE IN PALESTINE IN GOSPEL  
 TIMES . . . . . v. 3125  
 ARARAT . . . . . i. 247  
 ARCHES OF ANCIENT AQUEDUCT AT ANTIOCH  
 (Full Page) . . . . . i. 658  
 ARCHITECTURE—  
   1. Absalom's Pillar and Tombs of St.  
     James and Zacharias (Full Page) . . i. 234  
   2. Areopagus at Athens . . . . . i. 239  
   3. Artificial Mound, Marsovan Plain;  
     Possibly Hittite . . . . . i. 280  
   4. City Wall at Gezer . . . . . ii. 1222  
   5. Coliseum . . . . . iv. 2605  
   6. Colonnade at Amman (Rabbah) . . . iv. 2521  
   7. Doorway with Voluted Slabs at  
     Lachish . . . . . i. 235  
   8. Elevation of House from Court . . . . iii. 1436  
   9. Extremity of the Grand Colonnade  
     at Gerasa . . . . . ii. 1218  
   10. Ezekiel's Temple Plan . . . . . v. 2935  
   11. Front Elevation of Temple . . . . . v. 2938  
   12. Great Court Including Royal Build-  
     ings . . . . . v. 2932  
   13. Hittite Lion, Boghaz-keuy; at the  
     "Lion Gate" . . . . . i. 278  
   14. Hittite Warrior, Boghaz-keuy . . . . i. 278  
   15. Interior of Vizir Khan, Aleppo . . . . iii. 1470  
   16. Isometric Sketch of a House at Gezer . iii. 1435  
   17. Jewish Temple of Leontopolis . . . . i. 235  
   18. Lintel Stones . . . . . i. 236  
   19. Lion Gate at Boghaz-keuy . . . . . iii. 1396  
   20. Modern City of Es Salt . . . . . i. 234  
   21. Monuments in Assur, Discovered by  
     the Germans . . . . . iv. 2765  
   22. Obelisk at On . . . . . iv. 2193  
   23. Obelisk of Thothmes I . . . . . ii. 909  
   24. Old Jisr el-Mujamia, Roman Bridge  
     across the Upper Jordan River  
     (Full Page) . . . . . iv. 2602  
   25. Painted Tombs of Marissa . . . . . i. 236  
   26. Palace of Omri and Ahab at Samaria . iv. 2192  
   27. Pantheon . . . . . iv. 2621  
   28. Pillars and Hollow Stone of the High  
     Place at Gezer . . . . . iii. 1391  
   29. Plan of the Baths in the Castle at  
     Gezer . . . . . i. 414  
   30. Plan of House . . . . . iii. 1436  
   31. Plan of the Library at Nineveh . . . . iv. 2151  
   32. Plan of Pergamon . . . . . iii. 1885  
   33. Plan of Solomon's Temple . . . . . v. 2931  
   34. Robinson's Arch . . . . . iii. 1613  
   35. Roman Forum . . . . . iv. 2613  
   36. Ruins at Amman—Façade of Thea-  
     ter . . . . . iv. 2521  
   37. Ruins of One of Herod's Temples in  
     Samaria . . . . . iii. 1380  
   38. Ruins in Samaria . . . . . iv. 2671  
   39. St. Stephen's Gate . . . . . iii. 1603  
   40. Solomon's Temple—Schick's Model  
     (Full Page) . . . . . v. 2930  
   41. Streets of a Jewish City . . . . . i. 234  
   42. Synagogue at Kefr Berim . . . . . i. 237  
   43. Theater at Gerasa . . . . . ii. 1171  
   44. Tomb of Zechariah . . . . . i. 236  
   45. Tower of Antonia . . . . . ii. 1140  
   46. Tower of David . . . . . iii. 1619  
   47. Traditional House of Ananias . . . . ii. 780  
   48. Traditional House of Simon the  
     Tanner . . . . . iii. 1732  
   49. Traditional Megiddo—Ruins of  
     Palace and Public Buildings (Full  
     Page) . . . . . iii. 2028  
   50. Triple Gate—German Excavations  
     at Nablus (Full Page) . . . . . ii. 1138  
 AREOPAGUS AT ATHENS . . . . . i. 239  
 ARM-CHAIR OR THRONE . . . . . v. 2977  
 ARMOR, ARMS—  
   1. Assyrian Bronze Knives . . . . . iii. 1815  
   2. Battle-axes and Spears . . . . . i. 252  
   3. Bows, Arrows and Quiver . . . . . i. 252  
   4. Breastplate . . . . . i. 253  
   5. Egyptian Slinger . . . . . i. 252  
   6. Egyptian Stone Knives . . . . . iii. 1815  
   7. Egyptian Swords . . . . . i. 252  
   8. Greaves and Sandals . . . . . i. 254  
   9. Group of Ancient Arms . . . . . i. 251  
   10. Heavy-armed Greek Soldier . . . . . i. 251  
   11. Helmet . . . . . i. 253  
   12. Hittite Warrior—Boghaz-keuy . . . . i. 278  
   13. Hittite Warrior—Senjirli . . . . . iii. 1400  
   14. Persian Warriors . . . . . iv. 2336  
   15. Shield, Sword and Girdle . . . . . i. 253

- ARTIFICIAL MOUND, MARSOVAN PLAIN;  
POSSIBLY HITTITE . . . . . i. 280
- ASCENT TO AI: PATH TO ELIJAH'S TRANS-  
LATION . . . . . i. 87
- ASH . . . . . i. 286
- ASHTORETH . . . . . i. 271
- ASP . . . . . i. 286
- ASSES AT A MILL . . . . . i. 287
- ASSHUR-BANI-PAL HUNTING . . . . . i. 294
- ASSHUR-BANI-PAL'S ACCOUNT OF HIS RES-  
Toration OF THE STAGE-TOWER AT  
NIPPUR . . . . . i. 294
- ASSYRIA—
1. Asshur-bani-pal Hunting . . . . . i. 294
  2. Asshur-bani-pal's Account of His  
Restoration of the Stage-tower at  
Nippur . . . . . i. 294
  3. Assyrian Armed Galley in Motion . . . . . iv. 2775
  4. Assyrian Ax . . . . . i. 341
  5. Assyrian Balance . . . . . i. 380
  6. Assyrian Book . . . . . i. 497
  7. Assyrian Bronze Knives . . . . . iii. 1815
  8. Assyrian Chariot . . . . . i. 596
  9. Assyrian Dulcimer . . . . . iii. 2098
  10. Assyrian Fringed Garment . . . . . ii. 1146
  11. Assyrian Glass Bottles . . . . . i. 510
  12. Assyrian King in His Chariot . . . . . i. 292
  13. Assyrian King Placing His Foot on  
the Neck of an Enemy . . . . . ii. 1126
  14. Assyrian Lion Hunt . . . . . iii. 1441
  15. Assyrian Manner of Wearing Hair . . . . . ii. 1320
  16. Assyrian Ring with Wings . . . . . i. 304
  17. Assyrian Standards and Banners . . . . . i. 384
  18. Bas-relief of Sennacherib Besieging  
Lachish . . . . . iv. 2150
  19. Brick Stamp of Sargon I . . . . . i. 361
  20. Bronze and Stone Weights Used in  
Nineveh . . . . . v. 3079
  21. Egyptian and Assyrian Bracelets . . . . . i. 513
  22. Jehu's Tribute—from Obelisk of  
Shalmaneser . . . . . iii. 1584
  23. Monolith of Shalmaneser II . . . . . i. 436
  24. Monuments in Assur, Discovered by  
the Germans . . . . . iv. 2765
  25. Plan of the Library at Nineveh . . . . . iv. 2151
  26. Presentation of Umman-igas to His  
Subjects by the Assyrian General . . . . . ii. 921
  27. Procession of Assyrian Musicians . . . . . iii. 2097
  28. Sargon in His War Chariot . . . . . iv. 2693
  29. Sennacherib on His Throne before  
Lachish . . . . . iii. 1820
  30. Tiglath-pileser I . . . . . v. 2981
- ASSYRIAN ARMED GALLEY IN MOTION . . . . . iv. 2775
- ASSYRIAN AX . . . . . i. 341
- ASSYRIAN BALANCE . . . . . i. 380
- ASSYRIAN BOOK . . . . . i. 497
- ASSYRIAN BRONZE KNIVES . . . . . iii. 1815
- ASSYRIAN CHARIOT . . . . . i. 596
- ASSYRIAN DULCIMER . . . . . iii. 2098
- ASSYRIAN FRINGED GARMENT . . . . . ii. 1146
- ASSYRIAN GLASS BOTTLES . . . . . i. 510
- ASSYRIAN KING IN HIS CHARIOT . . . . . i. 292
- ASSYRIAN KING PLACING HIS FOOT ON THE  
NECK OF AN ENEMY . . . . . ii. 1126
- ASSYRIAN LION HUNT . . . . . iii. 1441
- ASSYRIAN MANNER OF WEARING HAIR . . . . . ii. 1320
- ASSYRIAN RING WITH WINGS . . . . . i. 304
- ASSYRIAN STANDARDS AND BANNERS . . . . . i. 384
- ASTRONOMY—
1. Assyrian Ring with Wings . . . . . i. 304
  2. Corona of Minimum Type . . . . . i. 303
  3. East—A Corner of the Milky Way . . . . . i. 306
  4. East—Star Swarms . . . . . i. 307
  5. Heaven, The Earth and the Abysses  
(Schiaparelli's Hebrew World) . . . . . i. 315
  6. Hercules and Draco . . . . . i. 309
  7. Hydra and the Neighboring Con-  
stellations . . . . . i. 310
  8. Ophinchus and the Neighboring Con-  
stellations . . . . . i. 310
  9. South—The Pleiades . . . . . i. 311
  10. Stars of the Plough, as the Winnow-  
ing Fan . . . . . i. 313
  11. Worshipping Heavenly Bodies . . . . . i. 370
  12. Worshipping the Lunar Deity . . . . . i. 371
- ATHENA PROMACHOS . . . . . ii. 1298
- ATTITUDES—
1. Bowing . . . . . i. 330
  2. Giving a Blessing . . . . . i. 329
  3. Kissing the Hand . . . . . i. 329
  4. Kneeling . . . . . i. 330
  5. Supplication: "Falling at the Feet" . . . . . i. 330
  6. Washing before Eating . . . . . i. 412
- AWLS . . . . . i. 341
- AXES . . . . . i. 341
- BAAL . . . . . i. 345
- BABYLON—
1. Babylonian Idols . . . . . i. 369
  2. Boundary Stone of Nebuchadnezzar  
I . . . . . iv. 2128
  3. Brick Bearing the Name of Nebuchad-  
rezzar . . . . . i. 352
  4. Bronze Goat Head from Tello . . . . . i. 359
  5. Building Inscription of Nabopolassar . . . . . i. 356
  6. Building Inscription of Nebuchad-  
rezzar II . . . . . i. 349
  7. Clay Tablet with Seal Inscription . . . . . i. 364
  8. The Deluge Tablet . . . . . i. 374
  9. Ea . . . . . i. 370
  10. From an Engraving on a Babylonian  
Cylinder Representing the Sun God  
and One of His Priests . . . . . i. 371
  11. Fragments of Inscribed Vases of the  
Early Sumerian Period . . . . . i. 360
  12. Mound Covering Nippur Tower . . . . . i. 349
  13. Nebo . . . . . i. 371
  14. Seal Cylinders . . . . . i. 363
  15. Silver Vase of Entemena . . . . . i. 359
  16. Statue of Gudea from Tello . . . . . i. 362
  17. Stone Object Containing an Inscrip-  
tion of Nebuchadnezzar I . . . . . i. 353
  18. Terra-cotta Cylinder Containing the  
History of the Capture of Babylon  
by Cyrus the Great . . . . . i. 575

19. Tomb of Cyrus . . . . . iv. 2336  
 20. Worshipping Heavenly Bodies . . . . . i. 370  
 21. Worshipping the Lunar Deity . . . . . i. 371  
 BABYLONIAN IDOLS . . . . . i. 369  
 BAG: SCRIP . . . . . i. 377  
 BAKING BREAD ON STONES . . . . . iii. 2013  
 BALANCE (FROM EGYPTIAN TOMB) . . . . . i. 380  
 BANK: MONEY CHANGER . . . . . i. 383  
 BANK OF THE NILE, ON THE . . . . . iv. 2145  
 BANNERS AND STANDARDS—  
 1. Assyrian Standards and Banners . . . . . i. 384  
 2. Egyptian Standards . . . . . i. 384  
 3. Roman Standards or Banners . . . . . v. 3070  
 BAS-RELIEF OF LION HUNT . . . . . iv. 2150  
 BAS-RELIEF OF SENNACHERIB BESIEGING  
 LACHISH . . . . . iv. 2150  
 BATHING AT THE NORTH END OF THE DEAD  
 SEA, THE MOUNTAINS OF MOAB IN THE  
 BACKGROUND . . . . . ii. 806  
 BATTERING-RAM . . . . . iv. 2787  
 BATTLE-AXES AND SPEARS . . . . . i. 252  
 BATTLE OF BETH-HORON . . . . . i. 447  
 BATS' EARS . . . . . i. 414  
 BAZAAR AT JAFFA . . . . . iii. 1995  
 BEARDED DARNEL . . . . . v. 2910  
 BEARDS . . . . . i. 418  
 BEDOUINS PLAYING ON PRIMITIVE INSTRU-  
 MENTS . . . . . iii. 2097  
 BEDSTEAD . . . . . i. 422  
 BEDS OF WHITE MARL AND SILT NEAR THE  
 DEAD SEA . . . . . i. 213  
 BEDAWIN OF MOAB . . . . . iii. 2070  
 BEERSHEBA, OVERLOOKING THE DESERT  
 (Full Page) . . . . . i. 424  
 BETHANY . . . . . i. 442  
 BETHEL . . . . . i. 444  
 BETHPHAGE . . . . . i. 451  
 BIRDS—  
 1. Bird Sign: Above a Four-horse  
 Chariot, Driven by a Goddess,  
 Appears an Eagle Flying . . . . . ii. 1300  
 2. Bittern . . . . . i. 484  
 3. Cormorant . . . . . i. 720  
 4. Crane . . . . . i. 737  
 5. Egyptian Fowler . . . . . ii. 1143  
 6. Gier-eagle . . . . . ii. 1228  
 7. Glede . . . . . ii. 1235  
 8. Heron . . . . . iii. 1384  
 9. Hoopoe . . . . . iii. 1419  
 10. Kestrel . . . . . ii. 1345  
 11. Ostriches . . . . . iv. 2203  
 12. Owl . . . . . iv. 2205  
 13. Partridge . . . . . iv. 2255  
 14. Pelican . . . . . iv. 2297  
 15. Pigeons . . . . . iv. 2395  
 16. Quail . . . . . iv. 2512  
 17. Raven . . . . . iv. 2533  
 18. Short-toed Eagle . . . . . ii. 885  
 19. Sparrow . . . . . v. 2839  
 20. Stork . . . . . v. 2863  
 21. Swift . . . . . v. 2874  
 22. Turtle-dove . . . . . ii. 872  
 BIRD SIGN: ABOVE A FOUR-HORSE CHARIOT,  
 DRIVEN BY A GODDESS, APPEARS AN  
 EAGLE FLYING . . . . . ii. 1300  
 BIT AND BRIDLE . . . . . i. 482  
 BITTERN . . . . . i. 484  
 BLACK-FIGURED VASE PAINTING . . . . . ii. 1302  
 BLOWPIPE AND SMALL FURNACE . . . . . iv. 2545  
 BOGHAZ-KEUY: THE HITTITE FORTRESS  
 CALLED YENIGE KALEH . . . . . ii. 1138  
 BOOKS—  
 1. Assyrian Book . . . . . i. 497  
 2. Egyptian Roll and Case . . . . . iv. 2597  
 3. Old Egyptian Bookcase . . . . . iii. 1886  
 4. Plan of the Library at Nineveh . . . . . iv. 2151  
 5. A Reader with a Roll . . . . . i. 499  
 6. Samaritan High Priest with Scroll . . . . . iv. 2313  
 7. Terra-cotta Cylinder Containing the  
 History of the Capture of Babylon  
 by Cyrus the Great . . . . . i. 575  
 8. A Writer, His Palette, and a Papyrus  
 Leaf . . . . . i. 496  
 BOTTLES—  
 1. Assyrian Glass Bottles . . . . . i. 510  
 2. Bottles of Skins . . . . . i. 510  
 3. Glass Bottles . . . . . ii. 1233  
 4. Water Carriers with Skin Bottles . . . . . i. 510  
 BOTTLES OF SKINS . . . . . i. 510  
 BOUNDARY STONE OF NEBUCHADREZZAR I. . . . . iv. 2128  
 BOWING . . . . . i. 330  
 BOWS, ARROWS AND QUIVER . . . . . i. 252  
 BOXING WITH THE CESTUS . . . . . ii. 1172  
 BREAD—  
 1. Arab Women Preparing Bread . . . . . i. 516  
 2. Baking Bread on Stones . . . . . iii. 2013  
 3. Egyptian Cakes or Loaves of Bread . . . . . i. 516  
 4. Egyptians Kneading Dough with  
 Their Feet . . . . . i. 515  
 5. Egyptians Kneading Dough with  
 Their Hands . . . . . i. 515  
 BREASTPLATE . . . . . i. 253  
 BREECHES OF THE HIGH PRIEST . . . . . i. 518  
 BRICK BEARING THE NAME OF NEBUCHAD-  
 REZZAR . . . . . i. 352  
 BRICK STAMP OF SARGON I. . . . . i. 361  
 BRIDGES—  
 1. Natural Bridge at Lebanon . . . . . i. 585  
 2. Old Jisr el-Mujamia, Roman Bridge  
 across Upper Jordan River (Full  
 Page) . . . . . iv. 2602  
 3. Roman Bridge over the Halys . . . . . i. 281  
 BRINGING HOME THE BARLEY HARVEST . . . . . i. 405  
 BROAD-TAILED SHEEP . . . . . iv. 2757  
 BRONZE GOAT HEAD FROM TELLO . . . . . i. 359  
 BRONZE PANEL FROM PALACE GATE AT  
 BALAWAT . . . . . i. 291  
 BRONZE AND STONE WEIGHTS USED IN  
 NINEVEH . . . . . v. 3079  
 BROOK CHERITH . . . . . iv. 2217  
 BROWN ANT . . . . . i. 139  
 BUILDING INSCRIPTION OF NABOPOLASSAR . . . . . i. 356  
 BUILDING INSCRIPTION OF NEBUCHADREZ-  
 ZAR II. . . . . i. 349

## BURIAL—

1. Burial Procession . . . . . i. 473
2. Cutting the Flesh . . . . . ii. 770
3. Interments in the Second Burial Cave at Gezer . . . . . iv. 2232
4. Mourners About a Couch on Which Rests the Body of the Dead . . . . . ii. 1303
5. Sacrificed Infant Buried in a Jar at Gezer . . . . . ii. 1224

## BURIAL PROCESSION . . . . . i. 473

## CAIRN ALTAR . . . . . i. 107

## CAMELS AT THE SEA OF GALILEE . . . . . i. 548

## CANA OF GALILEE . . . . . i. 548

## CANALS—

1. Canals in Egypt . . . . . i. 552
2. Ship-canal at Corinth . . . . . ii. 710

## CANALS IN EGYPT . . . . . i. 552

## CAPER . . . . . iii. 1445

## CARMEL OF JUDAH . . . . . i. 579

## CAROB TREE . . . . . iii. 1443

## CARP FOUND IN THE SEA OF GALILEE . . . . . ii. 1115

## CASSIA . . . . . i. 582

## CATAPULT FOR HURLING MISSILES . . . . . iv. 2788

## CATTLE . . . . . i. 584

## CAVE IN LEBANON CONVERTED INTO A SHRINE . . . . . i. 585

## CAVES—

1. Cave in Lebanon Converted into a Shrine . . . . . i. 585
2. Cenotaph over Tomb of Sarah in Mosque of Hebron above Cave of Machpelah (Full Page) . . . . . iii. 1960
3. Grotto of Jeremiah—"Gordon's Calvary" . . . . . ii. 1276
4. High Place of the Cave-dwellers at Gezer . . . . . iv. 2234
5. Interments in the Second Burial Cave at Gezer . . . . . iv. 2232
6. Mosque over the Cave of Machpelah at Hebron . . . . . ii. 1365
7. Plan of the Cave-dwellings at Gezer . . . . . iii. 1435
8. Signs of the Cave-dwellers . . . . . v. 3121
9. Stream Issuing from Cave at Afka, Lebanon . . . . . i. 585

## CEDARS OF LEBANON AT THE BESHERRI GROVE . . . . . i. 586

## CENOTAPH OVER TOMB OF SARAH IN MOSQUE OF HEBRON ABOVE CAVE OF MACHPELAH (Full Page) . . . . . iii. 1960

## CENSERS . . . . . i. 588

## CHAMELEON . . . . . i. 592

## CHAMOIS: PERSIAN WILD GOAT OR PASANG . . . . . i. 592

## CHANNEL OF WADY MUHAUWAT, AS IT ENTERS THE DEAD SEA . . . . . ii. 805

## CHORAZIN—RUINS OF JEWISH SYNAGOGUE (ONLY RUINS EXTANT) (Full Page) . . . . . v. 2878

## CITADEL OF ZION . . . . . v. 3151

## CITIES AND VILLAGES—

1. Anathoth, Jeremiah's Birthplace (Full Page) . . . . . iii. 1588
2. Approaches to a City . . . . . i. 663

## 3. Beersheba, Overlooking the Desert (Full Page) . . . . . i. 424

## 4. Chorazin—Ruins of Jewish Synagogue (only ruins extant) (Full Page) . . . . . v. 2378

## 5. City Gate . . . . . i. 664

## 6. City Wall at Gezer . . . . . ii. 1222

## 7. Gaza . . . . . ii. 1178

## 8. General View of Petra (Full Page) . . . . . iv. 2714

## 9. Ground Plan of Olympia . . . . . ii. 1299

## 10. Modern Arab Village . . . . . iii. 1437

## 11. Modern City of Es Salt . . . . . i. 234

## 12. Modern Jerusalem . . . . . iii. 1621

## 13. Nablus and Mount Ebal . . . . . iv. 2755

## 14. Ruins at Amman—Façade of Theater . . . . . iv. 2521

## 15. Ruins of Ancient Corinth with Acrocorinthus in Background . . . . . ii. 711

## 16. Streets of a Jewish City . . . . . i. 234

## 17. Tell el Hesi . . . . . i. 663

## 18. Tell Hum—Traditional Capernaum (Full Page) . . . . . i. 567

## 19. Tell Sandahannah . . . . . i. 662

## 20. Traditional Megiddo—Ruins of Palace and Public Buildings (Full Page) . . . . . iii. 2028

## 21. Walls of Tell ej Judeideh . . . . . i. 664

## CITRON . . . . . ii. 1278

## CITY GATE . . . . . i. 664

## CITY WALL AT GEZER . . . . . ii. 1222

## CLAY TABLET WITH SEAL INSCRIPTION . . . . . i. 364

## CLOTHES-MOTH . . . . . iii. 2091

## CODE OF HAMMURABI (Insert) . . . . . iii. 1854

## COINS—

## 1. Amicus Rufus . . . . . iii. 2079

## 2. Bank: Money Changer . . . . . i. 383

## 3. Chalkous of Pontius Pilate . . . . . iii. 2080

## 4. Coin of Agrippa . . . . . iii. 2079

## 5. Coin of Alexander Struck at Accho . . . . . iii. 2077

## 6. Coin of Antigonus . . . . . i. 553

## 7. Coin of Antiochus IV of Syria . . . . . iii. 2077

## 8. Coin of Antoninus Pius, Showing Anchor . . . . . iv. 2777

## 9. Coin of Aradus . . . . . iii. 2077

## 10. Coin of Ariarathes V, Philometer, King of Cappadocia . . . . . i. 568

## 11. Coin of Augustus . . . . . i. 332

## 12. Coin of Cyprus under Emperor Claudius . . . . . ii. 772

## 13. Coin of Cyrene . . . . . ii. 773

## 14. Coin of Elis—Zeus of Pheidias . . . . . ii. 1297

## 15. Coin of the Herods . . . . . iii. 2079

## 16. Coin of Licinius, Roman Emperor in the East . . . . . i. 281

## 17. Coin of Macedonia . . . . . iii. 1956

## 18. Coin of Philippi . . . . . iv. 2369

## 19. Coin of Ptolemy Soter . . . . . iii. 2078

## 20. Coin of Rhodes . . . . . iv. 2589

## 21. Coin of Sardis . . . . . iv. 2692

## 22. Coin Showing Image of Diana . . . . . ii. 961

## 23. Coin of Sidon . . . . . iii. 2077

## 24. Coin of Sidon . . . . . iv. 2786

25. Coin of Tarsus . . . . . v. 2915  
 26. Coin of Tyre . . . . . v. 3032  
 27. Coin of Tyre . . . . . iii. 2080  
 28. Coin of Vespasian, Representing Ju-  
 daea Mourning for Her Captivity iv. 2236  
 29. Denarius of Tiberius . . . . . ii. 830  
 30. Denarius of Tiberius . . . . . iii. 2080  
 31. Half-shekel, Year 1, 141 (?) BC . . . . . iii. 2078  
 32. Isthmian Crowns . . . . . ii. 1173  
 33. Mite of John Hyrcanus . . . . . iii. 2079  
 34. Octodrachm (Egyptian Talent) of  
 Ptolemy II . . . . . iv. 2499  
 35. One-fourth Shekel . . . . . iii. 2079  
 36. Reverse of a Coin of Aelia Capito-  
 lina . . . . . iii. 2080  
 37. Reverse of a Coin of Antigonos . . . . . iii. 2079  
 38. Roman Coin Commemorating Vic-  
 tory over the Jews . . . . . iii. 2080  
 39. Shekel, Simon Bar-cochba . . . . . iii. 2080  
 40. Shekel, Year 4, 138-7 (?) BC . . . . . iii. 2078  
 41. Tetradrachm (Attic Talent) of An-  
 tiochus III . . . . . i. 159  
 42. Tetradrachm of Augustus Struck at  
 Antioch . . . . . iii. 2080  
 43. Tetradrachm (Ptolemaic Talent) of  
 Alexander Balas . . . . . i. 91  
 44. Trumpets on a Coin from Bar-cochba iii. 2098  
 45. Year 3 . . . . . iii. 2078  
 COLISEUM . . . . . iv. 2605  
 COLOCYNTH . . . . . ii. 1287  
 COLONNADE AT AMMAN (RABBAH) . . . . . iv. 2521  
 COMBAT BETWEEN KING AND EVIL SPIRIT. iv. 2333  
 COMMON EGYPTIAN WRITING DURING THE  
 BONDAGE . . . . . v. 3125  
 COMMON EGYPTIAN WRITING IN THE TIME  
 OF ABRAHAM . . . . . v. 3124  
 CONSTRUCTION OF TABERNACLE, ACCORDING  
 TO FERGUSSON . . . . . v. 2890  
 CONVENT GARDEN, SINAI . . . . . iv. 2804  
 CORMORANT . . . . . i. 720  
 CORN AND PALM TREES IN GOSHEN . . . . . ii. 1280  
 CORNER OF WALL OF JERUSALEM FROM  
 KIDRON VALLEY (Full Page) . . . . . iii. 1602  
 CORONA OF MINIMUM TYPE . . . . . i. 303  
 COUCH BED WITH HEAD REST . . . . . i. 422  
 CRANE . . . . . i. 737  
 CROSS-SECTION OF NILOMETER . . . . . iv. 2146  
 CROSS-SECTIONS—  
 1. Cross-section of Nilometer . . . . . iv. 2146  
 2. Geological Cross-section of Southern  
 Palestine . . . . . i. 212  
 3. Map and Longitudinal Section of the  
 Dead Sea . . . . . ii. 803  
 4. Section from the Mediterranean to  
 Moab (after Lartet) . . . . . ii. 1216  
 5. Transverse Section of the Dead Sea. ii. 804  
 CUMMIN . . . . . ii. 766  
 CUNEIFORM TABLET FROM BOGHAZ-KEUY . . . . . i. 281  
 CUTTING THE FLESH . . . . . ii. 770  
 DAGON . . . . . ii. 776  
 DATE PALM WITH FRUIT . . . . . iv. 2235  
 DEAD SEA—  
 1. Bathing at the North End of the  
 Dead Sea, the Mountains of Moab  
 in the Background . . . . . ii. 806  
 2. Beds of White Marl and Silt near the  
 Dead Sea . . . . . i. 213  
 3. Channel of Wady Muhauwat, as It  
 Enters the Dead Sea . . . . . ii. 805  
 4. Jebel Usdum from the South, Looking  
 over the Mud Flat Covered by the  
 Sea in High Water . . . . . ii. 801  
 5. Map and Longitudinal Section of the  
 Dead Sea . . . . . ii. 803  
 6. North End of the Dead Sea, Border-  
 ing the Plain of Jericho . . . . . ii. 802  
 7. Salt Cliffs on the East Side of Jebel  
 Usdum . . . . . ii. 807  
 8. Section from the Mediterranean to  
 Moab (after Lartet) . . . . . ii. 1216  
 9. Shells from Ancient Bed of the Salt  
 Sea . . . . . i. 213  
 10. Shore Line at Southwest Corner of  
 the Dead Sea . . . . . ii. 802  
 11. Transverse Section of the Dead Sea. ii. 804  
 12. View from Ain Jidy, Looking South. ii. 808  
 13. View from the Heights behind Ma-  
 sada . . . . . ii. 809  
 14. View from Mount of Olives Over-  
 looking the Dead Sea (Full Page) . ii. 802  
 DELUGE TABLET, THE . . . . . i. 374  
 DENARIUS OF TIBERIUS . . . . . ii. 830  
 DESERT OF EDOM, IN THE . . . . . ii. 832  
 DIANA . . . . . ii. 843  
 DIPPING SKINS IN VATS OF SUMACH . . . . . v. 2908  
 DISCUS THROWER . . . . . ii. 1172  
 DOORWAY WITH VOLUTED SLABS AT LA-  
 CHISH . . . . . i. 235  
 DOTHAN . . . . . ii. 870  
 DOUBLE PIPE WITH ACCOMPANIMENT OF  
 CLAPPING OF HANDS . . . . . iii. 2099  
 DRESS—  
 1. Ancient Asiatic Crowns . . . . . ii. 762  
 2. Ancient Painting of an Egyptian  
 Princess (Full Page) . . . . . iv. 2360  
 3. Assyrian Fringed Garment . . . . . ii. 1146  
 4. Bag: Scrip . . . . . i. 377  
 5. Breeches of the High Priest . . . . . i. 518  
 6. Dress of Egyptian Priests . . . . . iv. 2440  
 7. Egyptian Amulets and Earrings . . . . . i. 127  
 8. Egyptian Anklets . . . . . i. 136  
 9. Egyptian and Assyrian Bracelets . . . . . i. 513  
 10. Egyptian Sandals . . . . . iv. 2779  
 11. Egyptian Signet Rings and Impres-  
 sions Made from Them . . . . . iv. 2594  
 12. Fringed Skirts from Tomb at Bab-el  
 Melook . . . . . ii. 1146  
 13. Median Dress . . . . . iii. 2017  
 14. Modern Druse Headdress . . . . . ii. 878  
 15. Native of Jericho . . . . . ii. 876  
 16. Painting at Beni Hassan . . . . . ii. 877  
 17. Phylacteries for Head and Arm . . . . . iv. 2393  
 18. Sandals . . . . . ii. 879



19. Sculpture on Behistun Rock . . . . . ii. 877  
 20. Shepherd of Bethany . . . . . ii. 876  
 21. Woman's Headdress and Veil  
 (Modern) . . . . . ii. 877  
 DRESS OF EGYPTIAN PRIESTS . . . . . iv. 2440  
 DRESSING HIDES IN A SYRIAN TANNERY . . v. 2909  
 DRUMS . . . . . iii. 2100  
 DRY WADY IN EDOM . . . . . i. 524
- EA . . . . . i. 370  
 EAST—A CORNER OF THE MILKY WAY . . . i. 306  
 EAST—STAR SWARMS . . . . . i. 307  
 EASTERN WATERPOTS . . . . . v. 3075  
 EBONY . . . . . ii. 894  
 EGYPT—
1. Ancient Egyptian Baskets . . . . . i. 413
  2. Ancient Egyptian Hinges . . . . . iii. 1393
  3. Ancient Egyptian Paintings on  
 Cloth (Full Page) . . . . . ii. 914
  4. Ancient Egyptian Temple—Philae  
 (Full Page) . . . . . ii. 1034
  5. Ancient Painting of an Egyptian  
 Princess (Full Page) . . . . . iv. 2360
  6. Balance (from Egyptian Tomb) . . . . i. 380
  7. On the Bank of the Nile . . . . . iv. 2145
  8. Canals in Egypt . . . . . i. 552
  9. Common Egyptian Writing during  
 the Bondage . . . . . v. 3125
  10. Common Egyptian Writing in the  
 Time of Abraham . . . . . v. 3124
  11. Dress of Egyptian Priests . . . . . iv. 2440
  12. Drums . . . . . iii. 2100
  13. Egyptian Amulets and Earrings . . . . i. 127
  14. Egyptian Anklets . . . . . i. 136
  15. Egyptian and Assyrian Bracelets . . . i. 513
  16. Egyptian Ax . . . . . i. 341
  17. Egyptian Bellows . . . . . i. 432
  18. Egyptian Cakes or Loaves of Bread . . i. 516
  19. Egyptian Cart . . . . . i. 581
  20. Egyptian Cymbals . . . . . iii. 2101
  21. Egyptian Dance—from Tomb at  
 Thebes . . . . . ii. 1169
  22. Egyptian Fowler . . . . . ii. 1143
  23. Egyptian Fuller . . . . . ii. 1148
  24. Egyptian Key . . . . . iii. 1794
  25. Egyptians Kneading Dough with  
 Their Feet . . . . . i. 515
  26. Egyptians Kneading Dough with  
 Their Hands . . . . . i. 515
  27. Egyptian Lyre Held Horizontally . . . . iii. 2097
  28. Egyptian Manner of Wearing Hair . . ii. 1320
  29. Egyptian Roll and Case . . . . . iv. 2597
  30. Egyptian Sandals . . . . . iv. 2779
  31. Egyptian Signet Rings and Impres-  
 sions Made from Them . . . . . iv. 2594
  32. Egyptian Slinger . . . . . i. 252
  33. Egyptian Standards . . . . . i. 384
  34. Egyptian Stone Knives . . . . . iii. 1815
  35. Egyptian Swords . . . . . i. 252
  36. Egyptian Threshing-floor . . . . . v. 2976
  37. Egyptian Throne . . . . . v. 2976
  38. Egyptian War Chariot . . . . . i. 595
39. Egyptian Water Wheel . . . . . iii. 1493  
 40. Elephant's Tusks Brought to Thoth-  
 mes III . . . . . iii. 1544  
 41. First Cataract of the Nile . . . . . ii. 907  
 42. Great Pyramid of Khufu . . . . . ii. 908  
 43. High Priest (Egyptian) . . . . . iv. 2441  
 44. "Israel" Stele in Museum at Cairo  
 (Full Page) . . . . . iii. 1516  
 45. King Merenptah . . . . . ii. 912  
 46. Large Foot Press (Egyptian) . . . . . v. 3087  
 47. Map of Ancient Alexandria . . . . . i. 94  
 48. Modern Egyptian Writing Materials . v. 3119  
 49. Obelisk at On . . . . . iv. 2193  
 50. Obelisk of Thothmes I . . . . . ii. 909  
 51. Octodrachm (Egyptian Talent) of  
 Ptolemy II . . . . . iv. 2499  
 52. Old Egyptian Bookcase . . . . . iii. 1886  
 53. Pharaoh . . . . . iv. 2359  
 54. Plan of Egyptian Garden with House,  
 Temple or Chapel, Vineyard, Tanks  
 of Water or Ponds, and Summer  
 Houses . . . . . ii. 1174  
 55. Potters at Work (Egyptian) . . . . . iv. 2424  
 56. Scarab with Name of Amenhotep  
 III, from Gezer . . . . . ii. 1223  
 57. Seti I . . . . . ii. 910  
 58. Statue of Rameses II at Luqsor . . . . ii. 911  
 59. Statue of Rameses II at Memphis . . . iii. 2031  
 60. Various Forms of Egyptian Harps . . . iii. 2099
- EGYPTIAN AMULETS AND EARRINGS . . . . . i. 127  
 EGYPTIAN ANKLETS . . . . . i. 136  
 EGYPTIAN AND ASSYRIAN BRACELETS . . . . i. 513  
 EGYPTIAN AX . . . . . i. 341  
 EGYPTIAN BELLOWS . . . . . i. 432  
 EGYPTIAN CAKES OR LOAVES OF BREAD . . . i. 516  
 EGYPTIAN CART . . . . . i. 581  
 EGYPTIAN CYMBALS . . . . . iii. 2101  
 EGYPTIAN DANCE—FROM TOMB OF THEBES . ii. 1169  
 EGYPTIAN FOWLER . . . . . ii. 1143  
 EGYPTIAN FULLER . . . . . ii. 1148  
 EGYPTIAN KEY . . . . . iii. 1794  
 EGYPTIAN LYRE HELD HORIZONTALLY . . . . iii. 2097  
 EGYPTIAN MANNER OF WEARING HAIR . . . ii. 1320  
 EGYPTIAN ROLL AND CASE . . . . . iv. 2597  
 EGYPTIAN SANDALS . . . . . iv. 2779  
 EGYPTIAN SIGNET RINGS AND IMPRESSIONS  
 MADE FROM THEM . . . . . iv. 2594  
 EGYPTIANS KNEADING DOUGH WITH THEIR  
 FEET . . . . . i. 515  
 EGYPTIANS KNEADING DOUGH WITH THEIR  
 HANDS . . . . . i. 515  
 EGYPTIAN SLINGER . . . . . i. 252  
 EGYPTIAN STANDARDS . . . . . i. 384  
 EGYPTIAN STONE KNIVES . . . . . iii. 1815  
 EGYPTIAN SWORDS . . . . . i. 252  
 EGYPTIAN THRESHING-FLOOR . . . . . v. 2976  
 EGYPTIAN THRONE . . . . . v. 2976  
 EGYPTIAN WAR CHARIOT . . . . . i. 595  
 EGYPTIAN WATER WHEEL . . . . . iii. 1493
- ELAM, ELAMITES—
1. The Installation of Umman-igas . . . . ii. 920
  2. Last Stand of Te-umman . . . . . ii. 921

3. Naram-Sin . . . . . ii. 919  
 4. Presentation of Umman-igas to His  
 Subjects by the Assyrian General. ii. 921  
 5. The Spinning Woman . . . . . ii. 922  
 ELEPHANT'S TUSKS BROUGHT TO THOTHMES  
 III. . . . . iii. 1544  
 ELEVATION OF HOUSE FROM COURT. . . . . iii. 1436  
 EN-DOR . . . . . ii. 944  
 EN-GEDI. . . . . ii. 945  
 ENGRAVING ON A BABYLONIAN CYLINDER  
 REPRESENTING THE SUN GOD AND ONE  
 OF HIS PRIESTS, FROM AN. . . . . i. 371  
 ENTRANCE TO KOUYUNJIK . . . . . iv. 2149  
 ENTRANCE TO THE SIK . . . . . iv. 2714  
 EXCAVATING FOR CUNEIFORM TABLETS AT  
 BOGHAZ-KEUY. . . . . i. 277  
 EXCAVATIONS—  
 1. Excavating for Cuneiform Tablets at  
 Boghaz-keuy. . . . . i. 277  
 2. Excavations at Jericho. . . . . iv. 2230  
 3. Excavations on Southeastern Hill of  
 Jerusalem (Full Page). . . . . iv. 2226  
 4. Plan Showing Results of Warren's  
 Excavations at "Robinson's Arch" iii. 1612  
 5. Stamped Jar-handles Excavated at  
 Gezer. . . . . iv. 2233  
 6. Triple Gate—German Excavations  
 at Nablus (Full Page). . . . . ii. 1138  
 EXCAVATIONS AT JERICHO. . . . . iv. 2230  
 EXCAVATIONS ON SOUTHEASTERN HILL OF  
 JERUSALEM (Full Page). . . . . iv. 2226  
 EXTERIOR OF GARDEN TOMB. . . . . i. 531  
 EXTERIOR OF POTTERY. . . . . iv. 2426  
 EXTREMITY OF THE GRAND COLONNADE AT  
 GERASA. . . . . ii. 1218  
 EZEKIEL'S TEMPLE PLAN. . . . . v. 2935  
 FACSIMILE OF CODEX EPHRAEMI RESCRIPTUS  
 . . . . . v. 2953  
 FACSIMILE OF CODEX SINAITICUS. . . . . v. 2951  
 FACSIMILE MINUSCULE MANUSCRIPT. . . . . v. 2954  
 FIELD OF BOAZ. . . . . i. 491  
 FIG. . . . . ii. 1109  
 FIGHTING WITH WILD BEASTS. . . . . ii. 1172  
 FIRE ALTARS. . . . . iv. 2334  
 FIRST CATARACT OF THE NILE. . . . . ii. 907  
 FISHERS MENDING THEIR NETS BY THE SEA  
 OF GALILEE. . . . . ii. 1116  
 FISHES OF THE SEA OF GALILEE. . . . . ii. 1115  
 FISHING—  
 1. Carp Found in the Sea of Galilee. . . . . ii. 1115  
 2. Fishers Mending Their Nets by the  
 Sea of Galilee. . . . . ii. 1116  
 3. Fishes of the Sea of Galilee. . . . . ii. 1115  
 4. Fishing on the Sea of Galilee. . . . . ii. 1166  
 FLAX. . . . . ii. 1118  
 FOOT RACE. . . . . ii. 1173  
 FOREIGN CAPTIVES EMPLOYED IN MAKING  
 BRICKS AT THEBES. . . . . i. 521  
 FOUNDATION SACRIFICE FOUND AT GEZER. . . . . i. 550  
 FOUNTAIN AT ASKAR. . . . . v. 2876  
 FOUNTAIN AT KHAN MINYEH, THE. . . . . i. 567  
 FOX. . . . . ii. 1144  
 FRAGMENTS OF INSCRIBED VASES OF THE  
 EARLY SUMERIAN PERIOD. . . . . i. 360  
 FRANKINCENSE. . . . . ii. 1144  
 FRINGED SKIRTS FROM TOMB AT BAB-EL  
 MELOOK. . . . . ii. 1146  
 FRONT ELEVATION OF TEMPLE. . . . . v. 2938  
 GAMES—  
 1. Boxing with the Cestus. . . . . ii. 1172  
 2. Discus Thrower. . . . . ii. 1172  
 3. Fighting with Wild Beasts. . . . . ii. 1172  
 4. Foot Race. . . . . ii. 1173  
 5. Isthmian Crowns. . . . . ii. 1173  
 6. Ruins at Amman—Façade of  
 Theater. . . . . iv. 2521  
 7. Theater at Gerasa. . . . . ii. 1171  
 GAZA. . . . . ii. 1178  
 GAZELLE. . . . . ii. 1179  
 GECKO. . . . . iii. 1906  
 GEHENNA AND AKELDAMA. . . . . iii. 1394  
 GENERAL VIEW OF PETRA (Full Page). . . . . iv. 2714  
 GEOLOGICAL CROSS-SECTION OF SOUTHERN  
 PALESTINE. . . . . i. 212  
 GEOLOGICAL MAP OF BIBLE LANDS (Insert). . . . . ii. 1216  
 GETHESEMANE. . . . . ii. 1221  
 GEZER—  
 1. City Wall at Gezer. . . . . ii. 1222  
 2. Foundation Sacrifice Found at Gezer. . . . . i. 550  
 3. Hebrew Inscribed Tablet from Gezer. . . . . i. 105  
 4. High Place of the Cave-dwellers at  
 Gezer. . . . . iv. 2234  
 5. "Household God" from Gezer. . . . . iii. 1455  
 6. Interments in the Second Burial Cave  
 at Gezer. . . . . iv. 2232  
 7. Isometric Sketch of a House at  
 Gezer. . . . . iii. 1435  
 8. Lamp and Bowls Discovered at  
 Gezer. . . . . iv. 2234  
 9. Pillars and Hollow Stone of the High  
 Place at Gezer. . . . . iii. 1391  
 10. Plan of the Baths in the Castle at  
 Gezer. . . . . i. 414  
 11. Plan of the Cave-dwellings at Gezer. . . . . iii. 1435  
 12. Reservoir at Gezer. . . . . i. 658  
 13. Sacrificed Infant Buried in a Jar at  
 Gezer. . . . . ii. 1224  
 14. Scarab with Name of Amenhotep III,  
 from Gezer. . . . . ii. 1223  
 15. Series of Baths in the Castle at Gezer. . . . . i. 415  
 16. Stamped Jar-handles Excavated at  
 Gezer. . . . . iv. 2233  
 17. Stone Altar of Gezer. . . . . i. 108  
 "GIDEON'S FOUNTAIN" IN THE PLAIN OF  
 ESDRAELON. . . . . ii. 993  
 GIER-EAGLE. . . . . ii. 1228  
 GIVING A BLESSING. . . . . i. 329  
 GLASS BOTTLES. . . . . ii. 1233  
 GLASS VASES. . . . . ii. 1233  
 GLEDE. . . . . ii. 1235  
 GOD AMON HOLDING CAPTIVE THE CITIES  
 OF JUDAH FOR SHISHAK, THE. . . . . iv. 2778

GOING TO MARKET . . . . . i.	534	HEAD OF THE BEARDED DIONYSUS . . . . . ii.	1300
GOING TO MARKET . . . . . iii.	1996	HEAD FROM OLD SAMSOUN . . . . . i.	277
GOLDEN CANDLESTICK . . . . . i.	553	HEADS OF AMORITES, AKIN TO NORTH	
GREAT COURT, INCLUDING ROYAL BUILD-		AFRICAN . . . . . i.	119
INGS . . . . . v.	2932	HEADS OF PHILISTINES . . . . . iv.	2378
GREAT PYRAMID OF KHUFU . . . . . ii.	908	HEATHEN DEITIES—	
"THE GREAT SEA" UNDER THE TEMPLE . . . i.	658	1. Ahura Mazda . . . . . iv.	2332
GREAVES AND SANDALS . . . . . i.	254	2. Aphrodite . . . . . ii.	1298
GREECE—		3. Ashtoreth . . . . . i.	271
1. Acropolis and Areopagus, Athens . . . i.	319	4. Athena Promachos . . . . . ii.	1298
2. Aphrodite . . . . . ii.	1298	5. Baal . . . . . i.	345
3. Areopagus at Athens . . . . . i.	239	6. Babylonian Idols . . . . . i.	369
4. Athena Promachos . . . . . ii.	1298	7. Coin of Elis—Zeus of Pheidias . . . . . ii.	1297
5. Bird Sign: Above a Four-horse		8. Dagon . . . . . ii.	776
Chariot, Driven by a Goddess,		9. Diana . . . . . ii.	843
Appears an Eagle Flying . . . . . ii.	1300	10. Ea . . . . . i.	370
6. Black-figured Vase Painting . . . . . ii.	1302	11. From an Engraving on a Babylonian	
7. Coin of Elis—Zeus of Pheidias . . . . . ii.	1297	Cylinder Representing the Sun	
8. Ground Plan of Olympia . . . . . ii.	1299	God and One of His Priests . . . . . i.	371
9. Head of the Bearded Dionysus . . . . . ii.	1300	12. The God Amon Holding Captive the	
10. Heavy-armed Greek Soldier . . . . . i.	251	Cities of Judah for Shishak . . . . . iv.	2778
11. Isthmian Crowns . . . . . ii.	1173	13. Head of the Bearded Dionysus . . . . . ii.	1300
12. Mourners about a Couch on Which		14. "Household God" from Gezer . . . . . iii.	1455
Rests the Body of the Dead . . . . . ii.	1303	15. Nebo . . . . . i.	371
13. Orestes Pursued by Two Erinyes . . . . . ii.	1304	16. Priest-king and God of Cultivation . . . . . iii.	1399
14. Persian Satrap Dictating Terms to		17. River-god . . . . . ii.	1300
Grecian Chiefs at the Gate of a		18. Storm-god Tessupas . . . . . iii.	1401
City. (Bas-relief from Lycian		19. Worshipping Heavenly Bodies . . . . . i.	370
Monument.) . . . . . ii.	1176	20. Worshipping the Lunar Deity . . . . . i.	371
15. Plan of the Precincts of Apollo's		21. Zeus from Mylasa . . . . . ii.	1297
Temple at Delphi . . . . . ii.	1301	HEAVEN, THE EARTH AND THE ABYSSES	
16. Purification . . . . . ii.	1302	(SCHIAPARELLI'S HEBREW WORLD) . . . . . i.	315
17. River-god . . . . . ii.	1300	HEAVY-ARMED GREEK SOLDIER . . . . . i.	251
18. Ruins of Ancient Corinth with Acro-		HEBREW INSCRIBED TABLET FROM GEZER . . . . . i.	105
Corinthus in Background . . . . . ii.	711	HEIGHTS BEHIND MASADA . . . . . ii.	809
19. Ruins of Eleusis . . . . . ii.	1303	HELMET . . . . . i.	253
20. Ship-canal at Corinth . . . . . ii.	710	HERCULES AND DRACO . . . . . i.	309
21. Temple of Jupiter at Athens . . . . . i.	320	HERON . . . . . iii.	1384
22. Tetradrachm (Attic Talent) of An-		HIEROGLYPHIC WRITING . . . . . v.	3118
tiochus III. . . . . i.	159	HIGH PLACE OF THE CAVE-DWELLERS AT	
23. Votive Offering . . . . . ii.	1302	GEZER . . . . . iv.	2234
24. Zeus from Mylasa . . . . . ii.	1297	HIGH PRIEST . . . . . iv.	2441
GREEK PAPYRUS CONTAINING MATTHEW		HILLS AND VALLEYS OF JERUSALEM WITH	
1:1-9.12.13.14-20 . . . . . iv.	2241	MODERN NAMES . . . . . iii.	1599
GROTTO OF JEREMIAH—"Gordon's Cal-		HITTITE KING AND DAUGHTER . . . . . iii.	1398
vary" . . . . . ii.	1276	HITTITE LION, BOGHHAZ-KEYU; AT THE	
GROUND PLAN OF OLYMPIA . . . . . ii.	1299	"LION GATE" . . . . . i.	278
GROUND PLAN (OF TABERNACLE), ACCORD-		HITTITES—	
ING TO KEIL . . . . . v.	2889	1. Boghaz-keyu: The Hittite Fortress	
GROUP OF ANCIENT ARMS . . . . . i.	251	Called Yenige Kaleh . . . . . ii.	1138
GROUP OF CONIES . . . . . ii.	698	2. Hittite King and Daughter . . . . . iii.	1398
GROUP OF LEPERS BEGGING . . . . . iii.	1867	3. Hittite Lion, Boghaz-keyu; at the	
HALF-SHEKEL, YEAR 1, 141 (?) BC . . . . . iii.	2078	"Lion Gate" . . . . . i.	278
HAMMURABI—		4. Hittite Sculptures, Yasili-kaya (1) . . . . . i.	279
1. Code of Hammurabi (Insert) . . . . . iii.	1854	5. Hittite Sculptures, Yasili-kaya (2) . . . . . i.	279
2. Hammurabi Receiving the Laws . . . . . ii.	1328	6. Hittite Warrior—Boghaz-keyu . . . . . i.	278
3. Text of the Code of Hammurabi . . . . . ii.	1329	7. Hittite Warrior—Senjirli . . . . . iii.	1400
HAMMURABI RECEIVING THE LAWS . . . . . ii.	1328	8. Inscription and Mutilated Figure	
HANGING . . . . . iv.	2505	from Jerabis . . . . . iii.	1401
HARP, LYRE AND DOUBLE PIPE WITH MEN		9. Passage-frieze, Yasili-kaya . . . . . iii.	1399
AND WOMEN SINGING . . . . . iii.	2095	10. Priest-king and God of Cultivation . . . . . iii.	1399
		11. Storm-god Tessupas . . . . . iii.	1401

- HITTITE SCULPTURES, YASILI-KAYA . . . . . i. 279  
HITTITE WARRIOR—BOGHAZ-KEUY . . . . . i. 278  
HITTITE WARRIOR—SENJIRLI . . . . . iii. 1400  
HOODED SNAKE . . . . . i. 55  
HOOPE . . . . . iii. 1419  
HOUSE—  
1. Doorway with Voluted Slabs at Lachish . . . . . i. 235  
2. Elevation of House from Court . . . . . iii. 1436  
3. The Inn of the Good Samaritan . . . . . i. 64  
4. Isometric Sketch of a House at Gezer . . . . . iii. 1435  
5. Living-room of House . . . . . iii. 1436  
6. Palace of Omri and Ahab at Samaria . . . . . iv. 2192  
7. Plan of House . . . . . iii. 1436  
8. Traditional House of Ananias . . . . . ii. 780  
9. Traditional House of Simon the Tanner . . . . . iii. 1732  
10. Traditional Megiddo—Ruins of Palace and Public Buildings (Full Page) . . . . . iii. 2028  
11. Window . . . . . iii. 1436  
“HOUSEHOLD GOD” FROM GEZER . . . . . iii. 1455  
HUMAN BODY—  
1. Assyrian Manner of Wearing Hair . . . . . ii. 1320  
2. Beards . . . . . i. 418  
3. Egyptian Manner of Wearing Hair . . . . . ii. 1320  
4. Group of Lepers Begging . . . . . iii. 1867  
5. Modern Jew of Jericho with Long Side Locks . . . . . ii. 1321  
6. Painted Eyes . . . . . ii. 1070  
HUNTING DEER IN AN ENCLOSED FIELD . . . . . iii. 1441  
HYDRA AND THE NEIGHBORING CONSTELLATIONS . . . . . i. 310  
IMPLEMENTS OF AGRICULTURE . . . . . i. 75  
IMPRESSION OF A SEAL CYLINDER . . . . . i. 291  
INCENSE ALTARS OF SANDSTONE FOUND IN THE ROCK SHRINE AT SINAI . . . . . i. 109  
INK-WELLS AND PEN-CASE WITH INK-WELL . . . . . iii. 1469  
INN OF THE GOOD SAMARITAN, THE . . . . . i. 64  
INSCRIBED TABLET IMPRESSED WITH SEALS . . . . . iv. 2152  
INSCRIPTION AND MUTILATED FIGURE FROM JERABIS . . . . . iii. 1401  
INSCRIPTIONS—  
1. Asshur-bani-pal's Account of His Restoration of the Stage-tower at Nippur . . . . . i. 294  
2. Brick Bearing the Name of Nebuchadrezzar . . . . . i. 352  
3. Brick Stamp of Sargon I. . . . . i. 361  
4. Building Inscription of Nabopolassar . . . . . i. 356  
5. Building Inscription of Nebuchadrezzar II. . . . . i. 349  
6. Clay Tablet with Seal Inscription . . . . . i. 364  
7. Cuneiform Tablet from Boghaz-keuy . . . . . i. 281  
8. The Deluge Tablet . . . . . i. 374  
9. Hebrew Inscribed Tablet from Gezer . . . . . i. 105  
10. Inscribed Tablet Impressed with Seals . . . . . iv. 2152  
11. Inscription and Mutilated Figure from Jerabis . . . . . iii. 1401  
12. “Israel” Stele in Museum at Cairo (Full Page) . . . . . iii. 1516  
13. Moabite Stone . . . . . iii. 2071  
14. Monolith of Shalmaneser II. . . . . i. 436  
15. Niches and Tablets at Banias (Full Page) . . . . . i. 536  
16. Signs of the Cave-dwellers . . . . . v. 3121  
17. Siloam Inscription—Writing at Jerusalem at Time of Hezekiah . . . . . v. 3120  
18. Stone Object Containing an Inscription of Nebuchadrezzar I. . . . . i. 353  
19. Title on the Cross . . . . . v. 2988  
20. Warning Tablet of Herod's Temple . . . . . iv. 2254  
INSECTS—  
1. Brown Ant . . . . . i. 139  
2. Clothes-moth . . . . . iii. 2091  
3. Locust . . . . . iii. 1908  
4. Scarlet Insect . . . . . v. 3109  
5. Scorpion . . . . . iv. 2703  
6. Silkworm . . . . . iv. 2791  
7. Spider . . . . . v. 2840  
8. Sticks of Dried Locusts on Sculptures from Kouyunjik . . . . . iii. 1908  
INSTALLATION OF UMMAN-IGAS, THE . . . . . ii. 920  
INTERIOR OF GARDEN TOMB . . . . . i. 531  
INTERIOR OF POTTERY . . . . . iv. 2425  
INTERIOR OF TOMB AT MARISSA . . . . . iv. 2228  
INTERIOR OF TOMBS OF THE KINGS . . . . . i. 531  
INTERIOR OF VIZIR KHAN, ALEPPO . . . . . iii. 1470  
INTERMENTS IN THE SECOND BURIAL CAVE AT GEZER . . . . . iv. 2232  
ISOMETRIC SKETCH OF A HOUSE AT GEZER . . . . . iii. 1435  
“ISRAEL” STELE IN MUSEUM AT CAIRO (Full Page) . . . . . iii. 1516  
ISTHMIAN CROWNS . . . . . ii. 1173  
JABBOK, THE . . . . . iii. 1546  
JACKAL . . . . . iii. 1548  
JACOB'S WELL . . . . . iii. 1556  
JEBEL USDUM FROM THE SOUTH, LOOKING OVER THE MUD FLAT COVERED BY THE SEA IN HIGH WATER . . . . . ii. 801  
JEHU'S TRIBUTE—FROM OBELISK OF SHALMANESER . . . . . iii. 1584  
JERUSALEM—  
1. Citadel of Zion . . . . . v. 3151  
2. Corner of Wall of Jerusalem from Kidron Valley (Full Page) . . . . . iii. 1602  
3. Excavations on Southeastern Hill of Jerusalem (Full Page) . . . . . iv. 2226  
4. Front Elevation of Temple . . . . . v. 2938  
5. Great Court, Including Royal Buildings . . . . . v. 2932  
6. “The Great Sea” under the Temple . . . . . i. 658  
7. Hills and Valleys of Jerusalem with Modern Names . . . . . iii. 1599  
8. Jerusalem Beggars . . . . . i. 425  
9. Jerusalem of the Jebusites, as Captured by David . . . . . iii. 1614  
10. Kidron, Looking Southeast from the Wall of Jerusalem . . . . . iii. 1798  
11. Letter from the Governor of Jerusalem about 1375 BC. . . . . v. 3120

12. Modern Jerusalem . . . . . iii. 1621  
 13. Plan of the Environs of Jerusalem . . . . . iii. 1611  
 14. Plan Showing Results of Warren's Excavations at "Robinson's Arch" . . . . . iii. 1612  
 15. Plan of Solomon's Temple . . . . . v. 2931  
 16. Pools of Solomon . . . . . i. 659  
 17. Probable Course of Solomon's Wall . . . . . iii. 1607  
 18. Probable Course of the Three Walls Described by Josephus . . . . . iii. 1605  
 19. Probable Course of Walls and Position of the Principal Gates from Hezekiah till Long after Nehemiah . . . . . iii. 1606  
 20. "Robinson's Arch" . . . . . iii. 1613  
 21. St. Stephen's Gate . . . . . iii. 1603  
 22. Semi-diagrammatic Plan of "Warren's Shaft" and Other Rock Passages . . . . . iii. 1608  
 23. Siloam Inscription—Writing at Jerusalem at the Time of Hezekiah . . . . . v. 3120  
 24. Slope of Zion—Tyropoeon Valley at Right . . . . . v. 3151  
 25. Solomon's Temple—Schick's Model (Full Page) . . . . . v. 2930  
 26. Tower of David . . . . . iii. 1619  
 27. Typical Grove of Olive Trees at Jerusalem . . . . . iv. 2184  
 28. "Up to Jerusalem" from the Inn of the Good Samaritan . . . . . iv. 2122  
 29. Warning Tablet of Herod's Temple . . . . . iv. 2254  
 30. The Water-supply . . . . . iii. 1609  
 JERUSALEM BEGGARS . . . . . i. 425  
 JERUSALEM OF THE JEBUSITES, AS CAPTURED BY DAVID . . . . . iii. 1614  
 JEWELRY—  
 1. Ancient Asiatic Crowns . . . . . ii. 762  
 2. Ancient Seals from Originals in the British Museum . . . . . iv. 2708  
 3. Egyptian Amulets and Earrings . . . . . i. 127  
 4. Egyptian Anklets . . . . . i. 136  
 5. Egyptian and Assyrian Bracelets . . . . . i. 513  
 6. Egyptian Signet Rings and Impressions Made from Them . . . . . iv. 2594  
 JEWISH MNEMONIC FRINGES, 9TH CENTURY BC . . . . . v. 3117  
 JEWISH TEMPLE OF LEONTOPOLIS . . . . . i. 235  
 JORDAN LEAVING THE SEA OF GALILEE . . . . . iii. 1733  
 "JOSHUA'S OAK"—A TEREBINTH . . . . . iv. 2172  
 KESTREL . . . . . ii. 1345  
 KIDRON, LOOKING SOUTHEAST FROM THE WALL OF JERUSALEM . . . . . iii. 1798  
 KING MERENPTAH . . . . . ii. 912  
 KISSING THE HAND . . . . . i. 329  
 KNEELING . . . . . i. 330  
 LAMP AND BOWLS DISCOVERED AT GEZER . . . . . iv. 2234  
 LAMPS—  
 1. Figures 1, 2 . . . . . iii. 1825  
 2. Figures 3, 4, 6, 14 . . . . . iii. 1825  
 3. Figure 5 . . . . . iii. 1825  
 4. Figures 7, 8, 9, 10, 11 . . . . . iii. 1826  
 5. Figure 12 . . . . . iii. 1826  
 6. Figure 13 . . . . . iii. 1826  
 7. Lamp and Bowls Discovered at Gezer . . . . . iv. 2234  
 8. Stamped Jar-handles, Lamp and Iron Implements from Tombs at Beit Jibrin . . . . . iv. 2227  
 LAMPS: FIGURES 1-14 . . . . . iii. 1825-1826  
 LARGE FOOT PRESS (EGYPTIAN) . . . . . v. 3087  
 LARGE VINE AT JERICHO . . . . . v. 3050  
 LAST STAND OF TE-UMMAN . . . . . ii. 921  
 LATERAL VIEW OF TABERNACLE, ACCORDING TO KENNEDY . . . . . v. 2888  
 LEEK . . . . . iii. 1864  
 LENTIL . . . . . iii. 1866  
 LEOPARD . . . . . iii. 1866  
 LETTER FROM THE GOVERNOR OF JERUSALEM ABOUT 1375 BC . . . . . v. 3120  
 LINTEL STONES . . . . . i. 236  
 LION . . . . . iii. 1895  
 LION GATE AT BOGHAZ-KEUY . . . . . iii. 1396  
 LITTER . . . . . iii. 1905  
 LIVING-ROOM OF HOUSE . . . . . iii. 1436  
 LOCUST . . . . . iii. 1908  
 LOOPHOLES THROUGH WHICH ARROWS WERE SHOT . . . . . iv. 2765  
 LYRE HELD PERPENDICULARLY . . . . . iii. 2097  
 MAGDALA . . . . . iii. 1962  
 MAKING A PAPYRUS BOAT . . . . . iv. 2775  
 MANDRAKE . . . . . iii. 1981  
 MANUSCRIPTS—  
 1. Ancient Manuscripts on Papyrus (Insert) . . . . . iii. 2238  
 2. Code of Hammurabi (Insert) . . . . . iii. 1854  
 3. Facsimile of Codex Ephraemi Rescriptus . . . . . v. 2953  
 4. Facsimile of Codex Sinaiticus . . . . . v. 2951  
 5. Facsimile Minuscule Manuscript . . . . . v. 2954  
 6. Greek Papyrus Containing Matthew 1:1-9.12.13.14-20 . . . . . iv. 2241  
 7. New Sayings of Jesus . . . . . iv. 2241  
 8. Section of Codex Washingtoniensis—Mark 1:1-7 (Insert) . . . . . v. 2952  
 9. Timotheus Papyrus . . . . . iv. 2240  
 MAP OF ANCIENT ALEXANDRIA . . . . . i. 94  
 MAP AND LONGITUDINAL SECTION OF THE DEAD SEA . . . . . ii. 803  
 MAPS, PLANS AND DIAGRAMS—  
 1. Battle of Beth-horon . . . . . i. 447  
 2. Construction of Tabernacle, according to Fergusson . . . . . v. 2890  
 3. Cross-section of Nilometer . . . . . iv. 2146  
 4. Elevation of House from Court . . . . . iii. 1436  
 5. Ezekiel's Temple Plan . . . . . v. 2935  
 6. Front Elevation of Temple . . . . . v. 2938  
 7. Geological Cross-section of Southern Palestine . . . . . i. 212  
 8. Geological Map of Bible Lands (Insert) . . . . . ii. 1216  
 9. Great Court, Including Royal Buildings (Jerusalem) . . . . . v. 2932  
 10. Ground Plan of Olympia . . . . . ii. 1299

11. Ground Plan (of Tabernacle), according to Keil. . . . . v. 2889
12. Hills and Valleys of Jerusalem with Modern Names. . . . . iii. 1599
13. Isometric Sketch of a House at Gezer. . . . . iii. 1435
14. Jerusalem of the Jebusites, as Captured by David. . . . . iii. 1614
15. Lateral View of Tabernacle, according to Kennedy. . . . . v. 2888
16. Map of Ancient Alexandria. . . . . i. 94
17. Map and Longitudinal Section of the Dead Sea. . . . . ii. 803
18. Mount Sinai and the Adjacent Valleys. . . . . iv. 2802
19. Plan of the Baths in the Castle at Gezer. . . . . i. 414
20. Plan of the Cave-dwellings at Gezer. iii. 1435
21. Plan of Egyptian Garden with House, Temple or Chapel, Vineyard, Tanks of Water or Ponds, and Summer Houses. . . . . ii. 1174
22. Plan of the Environs of Jerusalem. . iii. 1611
23. Plan of House. . . . . iii. 1436
24. Plan of the Library at Nineveh. . . iv. 2151
25. Plan of Pergamon. . . . . iii. 1885
26. Plan of the Precincts of Apollo's Temple at Delphi. . . . . ii. 1301
27. Plan Showing Results of Warren's Excavations at "Robinson's Arch" iii. 1612
28. Plan of Solomon's Temple. . . . . v. 2931
29. Probable Course of Solomon's Wall. iii. 1607
30. Probable Course of the Three Walls Described by Josephus. . . . . iii. 1605
31. Probable Course of Walls and Position of the Principal Gates from Hezekiah till Long after Nehemiah. iii. 1606
32. Section from the Mediterranean to Moab (after Lartet). . . . . ii. 1216
33. Semi-diagrammatic Plan of "Warren's Shaft" and Other Rock Passages. . . . . iii. 1608
34. Serpentine Course of Siloam Aqueduct. . . . . iv. 2791
35. Sketch Map of the Environs of Hebron to Show the Various Proposed Sites of Mamre. . . . . iii. 1973
36. Tabernacle—Schick's Model (Full Page). . . . . v. 2890
37. Solomon's Temple—Schick's Model (Full Page). . . . . v. 2930
38. Transverse Section of the Dead Sea. . ii. 804
39. The Water-supply (of Jerusalem). . . iii. 1609
- MARKET-PLACE AT JAFFA. . . . . i. 533
- MAT. . . . . i. 421
- MATTRESS WITH PILLOW. . . . . i. 422
- MEDIAN DRESS. . . . . iii. 2017
- MESSAGE STICKS. . . . . v. 3116
- MILLET. . . . . iii. 2055
- MIRROR OF POLISHED BRONZE. . . . . ii. 1234
- MITE OF JOHN HYRCANUS. . . . . iii. 2079
- MIZPAH. . . . . iii. 2069
- MOABITE STONE. . . . . iii. 2071
- MODERN ARAB MARRIAGE PROCESSION. . . iii. 1997
- MODERN ARABS. . . . . i. 215
- MODERN ARABS ENCAMPED IN THE VALLEY OF ACHOR. . . . . i. 214
- MODERN ARAB VILLAGE. . . . . iii. 1437
- MODERN CART. . . . . i. 581
- MODERN CITY OF ES SALT. . . . . i. 234
- MODERN DRUSE HEADRESS. . . . . ii. 878
- MODERN EGYPTIAN WRITING MATERIALS. . v. 3119
- MODERN JERUSALEM. . . . . iii. 1621
- MODERN JEW OF JERICO WITH LONG SIDE LOCKS. . . . . ii. 1321
- MODERN ORIENTAL BASKETS. . . . . i. 413
- MODERN SYRIAN WINE PRESS (Full Page). . v. 3086
- MODERN TRAFFIC ON THE HALYS RIVER. . i. 280
- MOHAMMEDANS PRAYING IN THE MOSQUE AT DAMASCUS. . . . . ii. 1220
- MONKEY FROM THE PRAENESTINE MOSAIC. . i. 160
- MONOLITH OF SHALMANESER II. . . . . i. 436
- MONUMENTS IN ASSUR DISCOVERED BY THE GERMANS. . . . . iv. 2765
- MOSQUE OVER THE CAVE OF MACHPELAH AT HEBRON. . . . . ii. 1365
- MOUND COVERING NIPPUR TOWER. . . . . i. 349
- MOUNTAINS—
1. Anti-Lebanon: Souk-Wady-Barrada iii. 1862
  2. Ararat. . . . . i. 247
  3. Ascent to Ai: Path to Elijah's Translocation. . . . . i. 87
  4. Bathing at the North End of the Dead Sea, the Mountains of Moab in the Background. . . . . ii. 806
  5. Convent Garden, Sinai. . . . . iv. 2804
  6. Jebel Usdum from the South, Looking over the Mud Flat Covered by the Sea in High Water. . . . . ii. 801
  7. Mount Ebal. . . . . ii. 890
  8. Mount Gerizim with Shechem. . . . . ii. 1218
  9. Mount Nebo from the Spring Ain Neba. . . . . iv. 2127
  10. Mount of Olives from the Golden Gate. . . . . iv. 2187
  11. Mount Sinai and the Adjacent Valleys. . . . . iv. 2802
  12. Mount Tabor. . . . . v. 2901
  13. Nablus and Mount Ebal. . . . . iv. 2755
  14. Ras-es-Safsafah. . . . . iv. 2803
  15. Traditional Mount of the Precipitation near Nazareth. . . . . iv. 2221
  16. View from Mount of Olives Overlooking the Dead Sea (Full Page). . . . . ii. 802
  17. View from Top of Mount Sinai (Full Page). . . . . iv. 2802
- MOUNT EBAL. . . . . ii. 890
- MOUNT GERIZIM WITH SHECHEM. . . . . ii. 1218
- MOUNT NEBO FROM THE SPRING AIN NEBA. iv. 2127
- MOUNT OF OLIVES FROM THE GOLDEN GATE. iv. 2187
- MOUNT OF OLIVES OVERLOOKING THE DEAD SEA (Full Page). . . . . ii. 802
- MOUNT SINAI AND THE ADJACENT VALLEYS. iv. 2802
- MOUNT TABOR. . . . . v. 2901

MOURNERS ABOUT A COUCH ON WHICH RESTS THE BODY OF THE DEAD . . . . . ii.	1303	ORIENTAL BARBER, AN . . . . . i.	403
MUSIC—		OSTRACON WITH LUKE 22:70 f. . . . . iv.	2203
1. Ancient Horns and Curved Trumpets . . . . . v.	3025	OSTRICHES . . . . . iv.	2203
2. Assyrian Dulcimer . . . . . iii.	2098	OUTER BANKS OF THE DELTA OF THE JORDAN . . . . . iii.	1735
3. Bedouins Playing on Primitive Instruments . . . . . iii.	2097	OWL . . . . . iv.	2205
4. Double Pipe with Accompaniment of Clapping of Hands . . . . . iii.	2099	PAESTOS DISK, FACE A, THE . . . . . i.	104
5. Drums . . . . . iii.	2100	PAINTED EYES . . . . . ii.	1070
6. Egyptian Cymbals . . . . . iii.	2101	PAINTED TOMBS OF MARISSA . . . . . i.	236
7. Egyptian Lyre Held Horizontally . . . . . iii.	2097	PAINTING AT BENI HASSAN . . . . . ii.	877
8. Harp, Lyre and Double Pipe with Men and Women Singing . . . . . iii.	2095	PALACE OF OMRI AND AHAB AT SAMARIA . . . . . iv.	2192
9. Lyre Held Perpendicularly . . . . . iii.	2097	PANTHEON . . . . . iv.	2621
10. Musical Party . . . . . iii.	2096	PAPYRUS ANTIQUORUM . . . . . iv.	2239
11. Procession of Assyrian Musicians . . . . . iii.	2097	PAPYRUS MARSH WITH BOAT . . . . . v.	3121
12. Sistra . . . . . iii.	2101	PARIAH DOG AT BEIRUT . . . . . ii.	867
13. Straight Trumpets . . . . . iii.	2100	PARTHIAN HORSEMEN . . . . . iv.	2252
14. Three Bearded Men with Lyres . . . . . iii.	2095	PARTRIDGE . . . . . iv.	2255
15. Timbrel . . . . . iii.	2101	PART OF ROCK OF BEHISTUN . . . . . iv.	2329
16. Trumpets on a Coin from Barcochba . . . . . iii.	2098	PASSAGE-FRIEZE, YASILI-KAYA . . . . . iii.	1399
17. Various Forms of Egyptian Harps . . . . . iii.	2099	PASS OF MICHMASH . . . . . iii.	2048
MUSICAL PARTY . . . . . iii.	2096	PELICAN . . . . . iv.	2297
MUSTARD . . . . . iii.	2102	PERSIA—	
MYRRH . . . . . iii.	2103	1. Ahura Mazda . . . . . iv.	2332
MYRTLE . . . . . iii.	2103	2. Chamois: Persian Wild Goat or Pasang . . . . . i.	592
NABLUS AND MOUNT EBAL . . . . . iv.	2755	3. Persian Satrap Dictating Terms to Grecian Chiefs at the Gate of a City. (Bas-relief from Lycian Monument.) . . . . . ii.	1176
NAPHTALI . . . . . iv.	2119	4. Persian Warriors . . . . . iv.	2336
NARAM-SIN . . . . . ii.	919	5. Terra-cotta Cylinder Containing the History of the Capture of Babylon by Cyrus the Great . . . . . i.	575
NARD . . . . . v.	2840	6. Tomb of Cyrus . . . . . iv.	2336
NATIVE OF JERICHO . . . . . ii.	876	PERSIAN SATRAP DICTATING TERMS TO GRECIAN CHIEFS AT THE GATE OF A CITY. (BAS-RELIEF FROM LYCIAN MONUMENT.) . . . . . ii.	1176
NATURAL BRIDGE AT LEBANON . . . . . i.	585	PERSIAN WARRIORS . . . . . iv.	2336
NAZARETH, FROM THE ROAD TO THE PLAIN OF ESDRAELON . . . . . iv.	2124	PHILISTINE WAGONS . . . . . iv.	2378
NEBO . . . . . i.	371	PHARAOH . . . . . iv.	2359
NEO . . . . . iv.	2135	PHYLACTERIES FOR HEAD AND ARM . . . . . iv.	2393
NEW SAYINGS OF JESUS . . . . . iv.	2241	PIGEONS . . . . . iv.	2395
NICHES AND TABLETS AT BANIAS (Full Page) . . . . . i.	536	PILGRIMS BATHING IN THE JORDAN . . . . . iv.	2219
NORTH END OF THE DEAD SEA, BORDERING THE PLAIN OF JERICHO . . . . . ii.	802	PILLARS AND HOLLOW STONE OF THE HIGH PLACE AT GEZER . . . . . iii.	1391
OAK AT GILEAD, THE SINDEEYAN . . . . . iv.	2171	PINE FOREST AT BEIRUT . . . . . iv.	2399
OBELISK AT ON . . . . . iv.	2193	PISTACHIO NUT . . . . . iv.	2170
OBELISK OF THOTHMES I . . . . . ii.	909	PLAIN OF SHARON . . . . . iv.	2751
OCTODRACHM (EGYPTIAN TALENT) OF PTOLEMY II . . . . . iv.	2499	PLAN OF THE BATHS IN THE CASTLE AT GEZER . . . . . i.	414
OLD EGYPTIAN BOOKCASE . . . . . iii.	1886	PLAN OF THE CAVE-DWELLINGS AT GEZER . . . . . iii.	1435
OLD JISR EL-MUJAMIA, ROMAN BRIDGE ACROSS THE UPPER JORDAN RIVER (Full Page) . . . . . iv.	2602	PLAN OF EGYPTIAN GARDEN WITH HOUSE, TEMPLE OR CHAPEL, VINEYARD, TANKS OF WATER OR PONDS AND SUMMER HOUSES . . . . . ii.	1174
OLIVE . . . . . iv.	2185	PLAN OF THE ENVIRONS OF JERUSALEM . . . . . iii.	1611
OLIVE PRESS AT BANIAS NEAR DAN (Full Page) . . . . . iv.	2184	PLANE TREE . . . . . iv.	2407
ONE-FOURTH SHEKEL . . . . . iii.	2079	PLAN OF HOUSE . . . . . iii.	1436
OPHINCHUS AND THE NEIGHBORING CONSTELLATIONS . . . . . i.	310	PLAN OF THE LIBRARY AT NINEVEH . . . . . iv.	2151
ORESTES PURSUED BY TWO ERINYES . . . . . ii.	1304	PLAN OF PERGAMON . . . . . iii.	1885
		PLAN OF THE PRECINCTS OF APOLLO'S TEMPLE AT DELPHI . . . . . ii.	1301

- PLAN SHOWING RESULTS OF WARREN'S EXCAVATIONS AT "ROBINSON'S ARCH" . . . . . iii. 1612
- PLAN OF SOLOMON'S TEMPLE . . . . . v. 2931
- PLANTS—
1. Anise . . . . . i. 136
  2. Bearded Darnel . . . . . v. 2910
  3. Caper . . . . . iii. 1445
  4. Cassia . . . . . i. 582
  5. Colocynth . . . . . ii. 1287
  6. Cummin . . . . . ii. 766
  7. Flax . . . . . ii. 1118
  8. Frankincense . . . . . ii. 1144
  9. Large Vine at Jericho . . . . . v. 3050
  10. Leek . . . . . iii. 1864
  11. Lentil . . . . . iii. 1866
  12. Mandrake . . . . . iii. 1981
  13. Millet . . . . . iii. 2055
  14. Mustard . . . . . iii. 2102
  15. Myrrh . . . . . iii. 2103
  16. Myrtle . . . . . iii. 2103
  17. Nard . . . . . v. 2840
  18. *Papyrus Antiquorum* . . . . . iv. 2239
  19. Reed . . . . . iv. 2544
  20. Retem Bush . . . . . iii. 1781
  21. Rock-rose . . . . . iii. 2103
  22. Rue . . . . . iv. 2625
  23. Saffron . . . . . iv. 2661
  24. Wormwood . . . . . v. 3109
- PLOWING NEAR NAZARETH . . . . . iv. 2221
- PLOWING IN SYRIA WITH YOKE OF OXEN . . . . . v. 3127
- POMEGRANATE . . . . . iv. 2417
- POOL OF BETHESDA . . . . . i. 445
- POOL OF HEZEKIAH . . . . . iii. 1386
- POOLS OF SOLOMON . . . . . i. 659
- POTTER'S WHEEL STILL USED IN PALESTINE AND SYRIA . . . . . iv. 2424
- POTTERS AT WORK (EGYPTIAN) . . . . . iv. 2424
- PRESENTATION OF UMMAN-IGAS TO HIS SUBJECTS BY THE ASSYRIAN GENERAL . . . . . ii. 921
- PRIEST-KING AND GOD OF CULTIVATION . . . . . iii. 1399
- PRIMITIVE ALPHABETS (Insert) . . . . . i. 104
- PRIMITIVE PLOWING . . . . . i. 76
- PRIMITIVE SIGNS LIKE A . . . . . i. 104
- PROBABLE COURSE OF SOLOMON'S WALL . . . . . iii. 1607
- PROBABLE COURSE OF THE THREE WALLS DESCRIBED BY JOSEPHUS . . . . . iii. 1605
- PROBABLE COURSE OF WALLS AND POSITION OF THE PRINCIPAL GATES FROM HEZEKIAH TILL LONG AFTER NEHEMIAH . . . . . iii. 1606
- PROCESSION OF ASSYRIAN MUSICIANS . . . . . iii. 2097
- PURIFICATION . . . . . ii. 1302
- QUAIL . . . . . iv. 2512
- QUIPU, THE . . . . . v. 3117
- RACHEL'S TOMB . . . . . iv. 2524
- RAS-ES-SAFSAFEH . . . . . iv. 2803
- RAVEN . . . . . iv. 2533
- READER WITH A ROLL, A . . . . . i. 499
- REAPING AND BINDING SHEAVES . . . . . iv. 2534
- RECLINING ON COUCHES . . . . . iii. 2015
- REED . . . . . iv. 2544
- RESERVOIR AT GEZER . . . . . i. 658
- RETEM BUSH . . . . . iii. 1781
- REVERSE OF A COIN OF AELIA CAPITOLINA . . . . . iii. 2080
- REVERSE OF A COIN OF ANTIGONUS . . . . . iii. 2079
- RIVER-GOD . . . . . ii. 1300
- RIVER JORDAN, THE . . . . . iii. 1734
- RIVERS—
1. Abana River . . . . . ii. 779
  2. On the Bank of the Nile . . . . . iv. 2145
  3. Brook Cherith . . . . . iv. 2217
  4. Cross-section of Nilometer . . . . . iv. 2146
  5. First Cataract of the Nile . . . . . ii. 907
  6. Jordan Leaving the Sea of Galilee . . . . . iii. 1733
  7. Kidron, Looking Southeast from the Wall of Jerusalem . . . . . iii. 1798
  8. Modern Traffic on the Halys River . . . . . i. 280
  9. Natural Bridge at Lebanon . . . . . i. 585
  10. Old Jisr el-Mujamia, Roman Bridge across the Upper Jordan River (Full Page) . . . . . iv. 2602
  11. Outer Banks of the Delta of the Jordan . . . . . iii. 1735
  12. Pilgrims Bathing in the Jordan . . . . . iv. 2219
  13. River-god . . . . . ii. 1300
  14. The River Jordan . . . . . iii. 1734
  15. Roman Bridge over the Halys . . . . . i. 281
  16. Sources of the Jordan at Dan (Full Page) . . . . . ii. 782
  17. Stream Issuing from Cave at Afka, Lebanon . . . . . i. 585
  18. Traditional Site of the Brook Cherith . . . . . i. 603
  19. Water Wheel on River Orontes at Antioch (Full Page) . . . . . i. 158
- ROBINSON'S ARCH . . . . . iii. 1613
- ROCK ALTAR FROM TAANACH . . . . . i. 109
- ROCK ALTAR AT TELL EL-MUTASELLIM—MEGIDDO (Full Page) . . . . . iii. 1390
- ROCK-CUT AQUEDUCT . . . . . i. 659
- ROCK OF MASADA . . . . . iv. 2788
- ROCK-ROSE . . . . . iii. 2103
- ROCK TOMBS AT AMASIA . . . . . iv. 2418
- ROMAN BRIDGE OVER THE HALYS . . . . . i. 281
- ROMAN COIN COMMEMORATING VICTORY OVER THE JEWS . . . . . iii. 2080
- ROMAN FORUM . . . . . iv. 2613
- ROMAN SCOURGES . . . . . iv. 2704
- ROMAN SHIP, FROM TOMB AT POMPEII . . . . . iv. 2776
- ROMAN STANDARDS OR BANNERS . . . . . v. 3070
- ROME—
1. Coliseum . . . . . iv. 2605
  2. Nero . . . . . iv. 2135
  3. Old Jisr el-Mujamia, Roman Bridge across the Upper Jordan River (Full Page) . . . . . iv. 2602
  4. Pantheon . . . . . iv. 2621
  5. Roman Bridge over the Halys . . . . . i. 281
  6. Roman Forum . . . . . iv. 2613
  7. Roman Scourges . . . . . iv. 2704
  8. Roman Ship, from Tomb at Pompeii . . . . . iv. 2776
  9. Roman Standards or Banners . . . . . v. 3070
- RUE . . . . . iv. 2625



- RUINED CHURCH AT KURIET . . . . . iii. 1812  
 RUINS AT AMMAN—FAÇADE OF THEATER . . . . . iv. 2521  
 RUINS OF ANCIENT CORINTH WITH ACRO-  
 CORINTHUS IN BACKGROUND . . . . . ii. 711  
 RUINS OF ELEUSIS . . . . . ii. 1303  
 RUINS OF ONE OF HEROD'S TEMPLES IN  
 SAMARIA . . . . . iii. 1380  
 RUINS IN SAMARIA . . . . . iv. 2671  
 SACRIFICE—  
 1. Altar of Burnt Offering and Altar of  
 Incense . . . . . i. 107  
 2. Cairn Altar . . . . . i. 107  
 3. Fire Altars . . . . . iv. 2334  
 4. Foundation Sacrifice Found at Gezer . . . . . i. 550  
 5. Incense Altars of Sandstone Found  
 in the Rock Shrine at Sinai . . . . . i. 109  
 6. Rock Altar from Taanach . . . . . i. 109  
 7. Rock Altar at Tell el-Mutasellim—  
 Megiddo (Full Page) . . . . . iii. 1390  
 8. Sacrificed Infant Buried in a Jar at  
 Gezer . . . . . ii. 1224  
 9. Stone Altar of Gezer . . . . . i. 108  
 SACRIFICED INFANT BURIED IN A JAR AT  
 GEZER . . . . . ii. 1224  
 SAFED AND JEBEL JERMUK . . . . . v. 3006  
 SAFFRON . . . . . iv. 2661  
 ST. MARY'S WELL AT NAZARETH . . . . . ii. 874  
 ST. STEPHEN'S GATE . . . . . iii. 1603  
 SALT CLIFFS ON THE EAST SIDE OF JEBEL  
 USDUM . . . . . ii. 807  
 SAMARIA—  
 1. Mount Ebal . . . . . ii. 890  
 2. Mount Gerizim with Shechem . . . . . ii. 1218  
 3. Nablus and Mount Ebal . . . . . iv. 2755  
 4. Palace of Omri and Ahab at Samaria . . . . . iv. 2192  
 5. Ruins of One of Herod's Temples in  
 Samaria . . . . . iii. 1380  
 6. Ruins in Samaria . . . . . iv. 2671  
 7. Samaritan High Priest with Scroll . . . . . iv. 2313  
 8. Triple Gate—German Excavations at  
 Nablus (Full Page) . . . . . ii. 1138  
 SAMARITAN HIGH PRIEST WITH SCROLL . . . . . iv. 2313  
 SANDALS . . . . . ii. 879  
 SARGON IN HIS WAR CHARIOT . . . . . iv. 2693  
 SCARAB WITH NAME OF AMENHOTEP III,  
 FROM GEZER . . . . . ii. 1223  
 SCARLET INSECT . . . . . v. 3109  
 SCRIBE'S PALETTE . . . . . iii. 1469  
 SCRIBES WITH UTENSILS . . . . . v. 3123  
 SCORPION . . . . . iv. 2703  
 SCULPTURE ON BEHISTUN ROCK . . . . . ii. 877  
 SCULPTURE, PAINTING, ETC—  
 1. Ahura Mazda . . . . . iv. 2332  
 2. Ancient Egyptian Paintings on Cloth  
 (Full Page) . . . . . ii. 914  
 3. Ancient Painting of an Egyptian  
 Princess (Full Page) . . . . . iv. 2360  
 4. Aphrodite . . . . . ii. 1298  
 5. Asshur-bani-pal Hunting . . . . . i. 294  
 6. Assyrian King in His Chariot . . . . . i. 292  
 7. Assyrian King Placing His Foot on  
 the Neck of an Enemy . . . . . ii. 1126  
 8. Athena Promachos . . . . . ii. 1298  
 9. Bas-relief of Lion Hunt . . . . . iv. 2150  
 10. Bas-relief of Sennacherib Besieging  
 Lachish . . . . . iv. 2150  
 11. Bird Sign: Above a Four-horse  
 Chariot, Driven by a Goddess,  
 Appears an Eagle Flying . . . . . ii. 1300  
 12. Black-figured Vase Painting . . . . . ii. 1302  
 13. Bronze Goat Head from Tello . . . . . i. 359  
 14. Bronze Panel from Palace Gate at  
 Balawat . . . . . i. 291  
 15. Combat between King and Evil  
 Spirit . . . . . iv. 2333  
 16. Egyptian Dance—from Tomb at  
 Thebes . . . . . ii. 1169  
 17. Entrance to Kouyunjik . . . . . iv. 2149  
 18. Fragments of Inscribed Vases of the  
 Early Sumerian Period . . . . . i. 360  
 19. The God Amon Holding Captive the  
 Cities of Judah for Shishak . . . . . iv. 2778  
 20. Golden Candlestick . . . . . i. 553  
 21. Great Pyramid of Khufu . . . . . ii. 908  
 22. Hammurabi Receiving the Laws . . . . . ii. 1328  
 23. Hanging . . . . . iv. 2505  
 24. Head of the Bearded Dionysus . . . . . ii. 1300  
 25. Head from Old Samsoun . . . . . i. 277  
 26. Heads of Amorites, Akin to North  
 African . . . . . i. 119  
 27. Heads of Philistines . . . . . iv. 2378  
 28. Hittite King and Daughter . . . . . iii. 1398  
 29. Hittite Lion, Boghaz-keuy; at the  
 "Lion Gate" . . . . . i. 278  
 30. Hittite Sculptures, Yasili-kaya (1) . . . . . i. 279  
 31. Hittite Sculptures, Yasili-kaya (2) . . . . . i. 279  
 32. Hittite Warrior—Boghaz-keuy . . . . . i. 278  
 33. Hittite Warrior—Senjirli . . . . . iii. 1400  
 34. "Household God" from Gezer . . . . . iii. 1455  
 35. Impression of a Seal Cylinder . . . . . i. 291  
 36. The Installation of Umman-igas . . . . . ii. 920  
 37. Jehu's Tribute—from Obelisk of  
 Shalmaneser . . . . . iii. 1584  
 38. King Merenptah . . . . . ii. 912  
 39. Last Stand of Te-umman . . . . . ii. 921  
 40. Monkey from the Praenestine Mo-  
 saic . . . . . i. 160  
 41. Monolith of Shalmaneser II . . . . . i. 436  
 42. Monuments in Assur, Discovered by  
 the Germans . . . . . iv. 2765  
 43. Naram-Sin . . . . . ii. 919  
 44. Obelisk at On . . . . . iv. 2193  
 45. Obelisk of Thothmes I . . . . . ii. 909  
 46. Orestes Pursued by Two Erinyes . . . . . ii. 1304  
 47. Painting at Beni Hassan . . . . . ii. 877  
 48. Parthian Horsemen . . . . . iv. 2252  
 49. Passage-frieze, Yasili-kaya . . . . . iii. 1399  
 50. Persian Satrap Dictating Terms to  
 Grecian Chiefs at the Gate of a  
 City. (Bas-relief from Lycian  
 Monument.) . . . . . ii. 1176  
 51. Philistine Wagons . . . . . iv. 2378  
 52. Presentation of Umman-igas to His  
 Subjects by the Assyrian General . . . . . ii. 921

53. River-god . . . . . ii. 1300  
 54. Sculpture on Behistun Rock . . . . . ii. 877  
 55. Sennacherib on His Throne before Lachish . . . . . iii. 1820  
 56. Siege of a City . . . . . ii. 1139  
 57. Silver Vase of Entemena . . . . . i. 359  
 58. The Spinning Woman . . . . . ii. 922  
 59. Statue of Gudea from Tello . . . . . i. 362  
 60. Statue of Rameses II at Luqsor . . . . . ii. 911  
 61. Statue of Rameses II at Memphis . . . . . iii. 2031  
 62. Sticks of Dried Locusts on Sculptures from Kouyunjik . . . . . iii. 1908  
 63. A Subject People Paying Tribute . . . . . v. 3011  
 64. Tiglath-pileser I . . . . . v. 2981  
 65. Zeus from Mylasa . . . . . ii. 1297  
 SEA OF GALILEE . . . . . ii. 1165  
 SEAL CYLINDERS . . . . . i. 363  
 SEALED STONE AT ENTRANCE TO A TOMB . . . . . iv. 2709  
 SECTION OF CODEX WASHINGTONIENSIS—Mark 1:1-7 (Insert) . . . . . v. 2952  
 SECTION FROM THE MEDITERRANEAN TO MOAB (AFTER LARTET) . . . . . ii. 1216  
 SEMI-DIAGRAMMATIC PLAN OF "WARREN'S SHAFT" AND OTHER ROCK PASSAGES . . . . . iii. 1608  
 SENNACHERIB ON HIS THRONE BEFORE LACHISH . . . . . iii. 1820  
 SERIES OF BATHS IN THE CASTLE AT GEZER . . . . . i. 415  
 SERPENTINE COURSE OF SILOAM AQUEDUCT . . . . . iv. 2791  
 SETI I . . . . . ii. 910  
 SHEEP AT DOTHAN (Full Page) . . . . . iii. 1738  
 SHEKEL, SIMON BAR-COCHBA . . . . . iii. 2080  
 SHEKEL, YEAR 4, 138-7 (?) BC . . . . . iii. 2078  
 SHELLS FROM ANCIENT BED OF THE SALT SEA . . . . . i. 213  
 SHELLS OF *Murex trunculus* AT SIDON . . . . . iv. 2510  
 SHEPHERD OF BETHANY . . . . . ii. 876  
 SHEPHERD AND SHEEP . . . . . iv. 2763  
 SHEPHERD'S FIELD AND FIELD OF BOAZ, THE . . . . . i. 450  
 SHIELD, SWORD AND GIRDLE . . . . . i. 253  
 SHIP-CANAL AT CORINTH . . . . . ii. 710  
 SHIPS AND BOATS—  
 1. Assyrian Armed Galley in Motion . . . . . iv. 2775  
 2. Coin of Antoninus Pius, Showing Anchor . . . . . iv. 2777  
 3. Making a Papyrus Boat . . . . . iv. 2775  
 4. Modern Traffic on the Halys River . . . . . i. 280  
 5. Papyrus Marsh with Boat . . . . . v. 3121  
 6. Roman Ship, from Tomb at Pompeii . . . . . iv. 2776  
 7. Ship-canal at Corinth . . . . . ii. 710  
 8. Ships Drawn up on Coast of Black Sea . . . . . i. 483  
 SHITTIM WOOD . . . . . i. 27  
 SHORE LINE AT SOUTHWEST CORNER OF THE DEAD SEA . . . . . ii. 802  
 SHORT-TOED EAGLE . . . . . ii. 885  
 SHOWING "SHED" OF ARAB LOOM . . . . . v. 3078  
 SHOWING UPRIGHT LOOM . . . . . v. 3078  
 SIEGE OF A CITY . . . . . ii. 1139  
 SIGNS OF THE CAVE-DWELLERS . . . . . v. 3121  
 SILKWORM . . . . . iv. 2791  
 SILOAM INSCRIPTION—WRITING AT JERUSALEM AT THE TIME OF HEZEKIAH . . . . . v. 3120  
 SILVER VASE OF ENTEMENA . . . . . i. 359  
 SISTRA . . . . . iii. 2101  
 SITE OF ANCIENT JERICO . . . . . iii. 1592  
 SKETCH MAP OF THE ENVIRONS OF HEBRON TO SHOW THE VARIOUS PROPOSED SITES OF MAMRE . . . . . iii. 1973  
 SLAVE BEARING COVERED DISHES . . . . . ii. 854  
 SLOPE OF ZION—TYROPOBON VALLEY AT RIGHT . . . . . v. 3151  
 SNAKES—  
 1. Adder . . . . . iv. 2737  
 2. Asp . . . . . i. 286  
 3. Hooded Snake . . . . . i. 55  
 SOLOMON'S TEMPLE—SCHICK'S MODEL (Full Page) . . . . . v. 2930  
 SOURCES OF THE JORDAN AT DAN (Full Page) . . . . . ii. 782  
 SOUTH—THE PLEIADES . . . . . i. 311  
 SPARROW . . . . . v. 2839  
 SPIDER . . . . . v. 2840  
 SPINDLES . . . . . v. 2841  
 SPINNING WOMAN, THE . . . . . ii. 922  
 STAMPED JAR-HANDLES EXCAVATED AT GEZER . . . . . iv. 2233  
 STAMPED JAR-HANDLES, LAMP AND IRON IMPLEMENTS FROM TOMBS AT BEIT JIBRIN . . . . . iv. 2227  
 STARS OF THE PLOUGH, AS THE WINNOWER FAN . . . . . i. 313  
 STATUE OF GUDEA FROM TELLO . . . . . i. 362  
 STATUE OF RAMESES II AT LUQSOR . . . . . ii. 911  
 STATUE OF RAMESES II AT MEMPHIS . . . . . iii. 2031  
 STICKS OF DRIED LOCUSTS ON SCULPTURES FROM KOUYUNJIK . . . . . iii. 1908  
 STONE ALTAR OF GEZER . . . . . i. 108  
 STONE OBJECT CONTAINING AN INSCRIPTION OF NEBUCHADREZZAR I . . . . . i. 353  
 STONE IN QUARRIES AT BAALBEK . . . . . iv. 2513  
 STORK . . . . . v. 2863  
 STORM-GOD TESSUPAS . . . . . iii. 1401  
 STRAIGHT TRUMPETS . . . . . iii. 2100  
 STREAM ISSUING FROM CAVE AT AFKA, LEBANON . . . . . i. 585  
 STREETS OF A JEWISH CITY . . . . . i. 234  
 SUBJECT PEOPLE PAYING TRIBUTE, A . . . . . v. 3011  
 SUNRISE ON THE SEA OF GALILEE (Full Page) . . . . . ii. 1376  
 SUPPLICATION: "FALLING AT THE FEET" . . . . . i. 330  
 SWIFT . . . . . v. 2874  
 SYCAMINE OR BLACK MULBERRY . . . . . v. 2876  
 SYCOMORE . . . . . v. 2877  
 SYNAGOGUE AT KEFR BERIM . . . . . i. 237  
 SYRIAN BEAR . . . . . i. 417  
 SYRIAN PLOW, YOKE AND PICK . . . . . iv. 2409  
 TABERNACLE—  
 1. Censers . . . . . i. 588  
 2. Construction of Tabernacle, according to Fergusson . . . . . v. 2890  
 3. Golden Candlestick . . . . . i. 553  
 4. Ground Plan (of Tabernacle) according to Keil . . . . . v. 2889

5. Lateral View of Tabernacle, according to Kennedy . . . . . v. 2888

6. Tabernacle—Schick's Model (Full Page) . . . . . v. 2890

TABLE AND COUCHES WITH SEATS NUMBERED IN ORDER OF RANK . . . . . iii. 2015

TABLE SHOWING SCRIPT OF SEMITIC LANGUAGES . . . . . iv. 2314

TABLETS—

1. Brick Stamp of Sargon I. . . . . i. 361

2. Clay Tablet with Seal Inscription. . . . . i. 364

3. Cuneiform Tablet from Boghaz-keuy . . . . . i. 281

4. The Deluge Tablet. . . . . i. 374

5. Excavating for Cuneiform Tablets at Boghaz-keuy . . . . . i. 277

6. Hebrew Inscribed Tablet from Gezer . . . . . i. 105

7. Inscribed Tablet Impressed with Seals . . . . . iv. 2152

8. "Israel" Stele in Museum at Cairo (Full Page) . . . . . iii. 1516

9. Mosaic Stone . . . . . iii. 2071

10. Niches and Tablets at Baniyas (Full Page) . . . . . i. 536

11. Warning Tablet of Herod's Temple. . . . . iv. 2254

TELL EL HESY . . . . . i. 663

TELL HUM—TRADITIONAL CAPERNAUM (Full Page) . . . . . i. 567

TELL SANDAHANNAH . . . . . i. 662

TELL TAANACH . . . . . iii. 1390

TEMPLES, HEATHEN—

1. Ancient Egyptian Temple—Philae (Full Page) . . . . . ii. 1034

2. Cenotaph over Tomb of Sarah in Mosque of Hebron above Cave of Machpelah (Full Page) . . . . . iii. 1960

3. Mohammedans Praying in the Mosque at Damascus. . . . . ii. 1220

4. Mosque over the Cave of Machpelah at Hebron . . . . . ii. 1365

5. Plan of the Precincts of Apollo's Temple at Delphi . . . . . ii. 1301

6. Temple of Jupiter at Athens. . . . . i. 320

7. Temple of Tirhakah at Napata . . . . . ii. 1032

TEMPLE OF JUPITER AT ATHENS . . . . . i. 320

TEMPLE, THE—

1. Ezekiel's Temple Plan . . . . . v. 2935

2. Front Elevation of Temple . . . . . v. 2938

3. Great Court Including Royal Buildings . . . . . v. 2932

4. "The Great Sea" under the Temple. . . . . i. 658

5. Plan of Solomon's Temple . . . . . v. 2931

6. Solomon's Temple—Schick's Model (Full Page) . . . . . v. 2930

7. Warning Tablet of Herod's Temple. . . . . iv. 2254

TEMPLE OF TIRHAKAH AT NAPATA . . . . . ii. 1032

TERRA-COTTA CYLINDER CONTAINING THE HISTORY OF THE CAPTURE OF BABYLON BY CYRUS THE GREAT . . . . . i. 575

TETRADRACHM (ATTIC TALENT) OF ANTIOCHUS III. . . . . i. 159

TETRADRACHM OF AUGUSTUS STRUCK AT ANTIOCH . . . . . iii. 2080

TETRADRACHM (PTOLEMAIC TALENT) OF ALEXANDER BALAS . . . . . i. 91

TEXT OF THE CODE OF HAMMURABI . . . . . ii. 1329

THEATER AT GERASA . . . . . ii. 1171

THREE BEARDED MEN WITH LYRES . . . . . iii. 2095

THRESHING INSTRUMENT WITH SHARP TEETH . . . . . i. 76

THRESHING WITH OXEN . . . . . i. 77

THROUGH THE ROCKS AT JOPPA . . . . . ii. 1732

THYNE WOOD . . . . . v. 2978

TIBERIAS . . . . . v. 2978

TIGLATH-PILESER I. . . . . v. 2981

TIMBREL . . . . . iii. 2101

TIMOTHEUS PAPYRUS . . . . . iv. 2240

TITLE ON THE CROSS . . . . . v. 2988

TOMB OF CYRUS . . . . . iv. 2336

TOMBS—

1. Absalom's Pillar and Tombs of St. James and Zacharias (Full Page) . . . . . i. 234

2. Absalom's Tomb . . . . . i. 24

3. Balance (from Egyptian Tomb) . . . . . i. 380

4. Cenotaph over Tomb of Sarah in Mosque of Hebron above Cave of Machpelah (Full Page) . . . . . iii. 1960

5. Egyptian Dance—from Tomb at Thebes . . . . . ii. 1169

6. Exterior of Garden Tomb . . . . . i. 531

7. Fringed Skirts from Tomb at Bab-el Melook . . . . . ii. 1146

8. Interior of Garden Tomb . . . . . i. 531

9. Interior of Tomb at Marissa . . . . . iv. 2228

10. Interior of Tombs of the Kings . . . . . i. 531

11. Painted Tombs of Marissa . . . . . i. 236

12. Rachel's Tomb . . . . . iv. 2524

13. Rock Tombs at Amasia . . . . . iv. 2418

14. Roman Ship, from Tomb at Pompeii. . . . . iv. 2776

15. Sealed Stone at Entrance to a Tomb . . . . . iv. 2709

16. Stamped Jar-handles, Lamp and Iron Implements from Tombs at Beit Jibrin . . . . . iv. 2227

17. Tomb of Cyrus . . . . . iv. 2336

18. Tomb of Zechariah . . . . . i. 236

19. Tombs of the Kings . . . . . i. 530

20. Traditional Tomb of Lazarus . . . . . iii. 1860

TOMBS OF THE KINGS . . . . . i. 530

TOMB OF ZECHARIAH . . . . . i. 236

TOOLS—

1. Assyrian Ax . . . . . i. 341

2. Assyrian Bronze Knives . . . . . iii. 1815

3. Awls . . . . . i. 341

4. Axes . . . . . i. 341

5. Egyptian Ax . . . . . i. 341

6. Egyptian Key . . . . . iii. 1794

7. Egyptian Stone Knives . . . . . iii. 1815

8. Scribe's Palette . . . . . iii. 1469

9. Spindles . . . . . v. 2841

TOWER OF ANTONIA . . . . . ii. 1140

TOWER OF DAVID . . . . . iii. 1619

TRADES AND CRAFTS—

1. Ancient Oil Presses . . . . . iv. 2182

2. Ancient Pottery (Full Page) . . . . . iv. 2424

3. Bank: Money Changer . . . . . i. 383

4. Blowpipe and Small Furnace . . . . . iv. 2545  
 5. Dipping Skins in Vats of Sumach . . . v. 2908  
 6. Dressing Hides in a Syrian Tannery . . v. 2909  
 7. Egyptian Bellows . . . . . i. 432  
 8. Egyptian Fowler . . . . . ii. 1143  
 9. Egyptian Fuller . . . . . ii. 1148  
 10. Egyptians Kneading Dough with Their Feet . . . . . i. 515  
 11. Egyptians Kneading Dough with Their Hands . . . . . i. 515  
 12. Exterior of Pottery . . . . . iv. 2426  
 13. Fishers Mending Their Nets by the Sea of Galilee . . . . . ii. 1116  
 14. Fishing on the Sea of Galilee . . . . . ii. 1166  
 15. Foreign Captives Employed in Making Bricks at Thebes . . . . . i. 521  
 16. Interior of Pottery . . . . . iv. 2425  
 17. Large Foot Press (Egyptian) . . . . . v. 3087  
 18. Making a Papyrus Boat . . . . . iv. 2775  
 19. Modern Syrian Wine Press (Full Page) . . . . . v. 3086  
 20. Olive Press at Banias near Dan (Full Page) . . . . . iv. 2184  
 21. An Oriental Barber . . . . . i. 403  
 22. Potter's Wheel Still Used in Palestine and Syria . . . . . iv. 2424  
 23. Potters at Work (Egyptian) . . . . . iv. 2424  
 24. Showing "Shed" of Arab Loom . . . . v. 3078  
 25. Showing Upright Loom . . . . . v. 3078  
 26. Spindles . . . . . v. 2841  
 27. The Spinning Woman . . . . . ii. 922  
 28. A Vendor of Water (Full Page) . . . . v. 3074  
 29. Water Carriers with Skin Bottles . . . i. 510  
 30. Weaving (Figure 1) . . . . . v. 3077  
 31. Weaving (Figure 2) . . . . . v. 3077  
 32. Women at a Modern Mill . . . . . iii. 2052  
 TRADITIONAL HOUSE OF ANANIAS . . . . . ii. 780  
 TRADITIONAL HOUSE OF SIMON THE TANNER . . iii. 1732  
 TRADITIONAL MEGIDDO—RUINS OF PALACE AND PUBLIC BUILDINGS (Full Page) . . . . iii. 2028  
 TRADITIONAL MOUNT OF THE PRECIPITATION NEAR NAZARETH . . . . . iv. 2221  
 TRADITIONAL SITE OF THE BROOK CHERITH . . i. 603  
 TRADITIONAL TOMB OF LAZARUS . . . . . iii. 1860  
 TRANSVERSE SECTION OF THE DEAD SEA . . . ii. 804  
 TREES—  
 1. Abraham's Oak . . . . . ii. 1366  
 2. Algum Tree . . . . . i. 96  
 3. Almond Tree . . . . . i. 100  
 4. Aloes . . . . . i. 103  
 5. Carob Tree . . . . . iii. 1443  
 6. Cedars of Lebanon at the Besherri Grove . . . . . i. 586  
 7. Citron . . . . . ii. 1278  
 8. Corn and Palm Trees in Goshen . . . . ii. 1280  
 9. Date Palm with Fruit . . . . . iv. 2235  
 10. Ebony . . . . . ii. 894  
 11. Fig . . . . . ii. 1109  
 12. "Joshua's Oak"—a Terebinth . . . . . iv. 2172  
 13. Oak at Gilcad, the Sindeeyan . . . . . iv. 2171  
 14. Olive . . . . . iv. 2185  
 15. Pine Forest at Beirut . . . . . iv. 2399  
 16. Pistachio Nut . . . . . iv. 2170  
 17. Plane . . . . . iv. 2407  
 18. Pomegranate . . . . . iv. 2417  
 19. Shittim Wood . . . . . i. 27  
 20. Sycamore or Black Mulberry . . . . . v. 2876  
 21. Sycamore . . . . . v. 2877  
 22. Thyine Wood . . . . . v. 2978  
 23. Typical Grove of Olive Trees at Jerusalem . . . . . iv. 2184  
 TRIPLE GATE—GERMAN EXCAVATIONS AT NABLUS (Full Page) . . . . . ii. 1138  
 TRUMPETS ON A COIN FROM BAR-COCHBA . . . iii. 2098  
 TURTLE-DOVE . . . . . ii. 872  
 TYPICAL GROVE OF OLIVE TREES AT JERUSALEM . . . . . iv. 2184  
 TYRE . . . . . v. 3030  
 "UP TO JERUSALEM" FROM THE INN OF THE GOOD SAMARITAN . . . . . iv. 2122  
 UTENSILS AND FURNITURE—  
 1. Alabaster Boxes . . . . . i. 512  
 2. Ancient Egyptian Baskets . . . . . i. 413  
 3. Ancient Egyptian Hinges . . . . . iii. 1393  
 4. Ancient Seals from Originals in the British Museum . . . . . iv. 2708  
 5. Arab Tent . . . . . v. 2948  
 6. Arm-chair or Throne . . . . . v. 2977  
 7. Assyrian Ax . . . . . i. 341  
 8. Assyrian Balance . . . . . i. 380  
 9. Assyrian Bronze Knives . . . . . iii. 1815  
 10. Assyrian Glass Bottles . . . . . i. 510  
 11. Awls . . . . . i. 341  
 12. Axes . . . . . i. 341  
 13. Bedstead . . . . . i. 422  
 14. Bottles of Skins . . . . . i. 510  
 15. Bronze and Stone Weights Used in Nineveh . . . . . v. 3079  
 16. Censers . . . . . i. 588  
 17. Couch Bed with Head Rest . . . . . i. 422  
 18. Eastern Waterpots . . . . . v. 3075  
 19. Egyptian Ax . . . . . i. 341  
 20. Egyptian Bellows . . . . . i. 432  
 21. Egyptian Key . . . . . iii. 1794  
 22. Egyptian Roll and Case . . . . . iv. 2597  
 23. Egyptian Stone Knives . . . . . iii. 1815  
 24. Egyptian Throne . . . . . v. 2976  
 25. Glass Bottles . . . . . ii. 1233  
 26. Glass Vases . . . . . ii. 1233  
 27. Golden Candlestick . . . . . i. 553  
 28. Ink-wells and Pen-case with Ink-well . . iii. 1469  
 29. Lamp and Bowls Discovered at Gezer . . . . . iv. 2234  
 30. Lamps: Figures 1-14 . . . . . iii. 1825-1826  
 31. Mat . . . . . i. 421  
 32. Mattress with Pillow . . . . . i. 422  
 33. Mirror of Polished Bronze . . . . . ii. 1234  
 34. Modern Egyptian Writing Materials . . v. 3119  
 35. Modern Oriental Baskets . . . . . i. 413  
 36. Old Egyptian Bookcase . . . . . iii. 1886  
 37. Reclining on Couches . . . . . iii. 2015  
 38. Scribe's Palette . . . . . iii. 1469  
 39. Scribes with Utensils . . . . . v. 3123

40. Silver Vase of Entemena . . . . . i.	359	11. Boghaz-keuy: The Hittite Fortress Called Yenige Kaleh . . . . . ii.	1138
41. Slave Bearing Covered Dishes . . . . . ii.	854	12. Camels at the Sea of Galilee . . . . . i.	548
42. Spindles . . . . . v.	2841	13. Cana of Galilee . . . . . i.	548
43. Stamped Jar-handles Excavated at Gezer . . . . . iv.	2233	14. Canals in Egypt . . . . . i.	552
44. Stamped Jar-handles, Lamp and Iron Implements from Tombs at Beit Jibrin . . . . . iv.	2227	15. Carmel of Judah . . . . . i.	579
45. Table and Couches with Seats Num- bered in Order of Rank . . . . . iii.	2015	16. Citadel of Zion . . . . . v.	3151
46. A Vendor of Water (Full Page) . . . . . v.	3074	17. Convent Garden, Sinai . . . . . iv.	2804
47. Washing before Eating . . . . . i.	412	18. In the Desert of Edom . . . . . ii.	832
48. Water Carriers with Skin Bottles . . . . . i.	510	19. Dothan . . . . . ii.	870
49. A Writer, His Palette, and a Papyrus Leaf . . . . . i.	496	20. Dry Wady in Edom . . . . . i.	524
VALLEY OF AIJALON . . . . . i.	88	21. En-dor . . . . . ii.	944
VALLEY OF JEHOSEPHAT . . . . . iii.	1583	22. En-gedi . . . . . ii.	945
VALLEYS—		23. Entrance to the Sik . . . . . iv.	2714
1. Corner of Wall of Jerusalem from Kidron Valley (Full Page) . . . . . iii.	1602	24. Field of Boaz . . . . . i.	491
2. Hills and Valleys of Jerusalem with Modern Names . . . . . iii.	1599	25. The Fountain at Khan Minyeh . . . . . i.	567
3. Modern Arabs Encamped in the Valley of Achor . . . . . i.	214	26. Gehenna and Akeldama . . . . . iii.	1394
4. Mount Sinai and the Adjacent Val- leys . . . . . iv.	2802	27. General View of Petra (Full Page) . . . . . iv.	2714
5. Slope of Zion—Tyropoeon Valley at Right . . . . . v.	3151	28. Gethsemane . . . . . ii.	1221
6. Valley of Aijalon . . . . . i.	88	29. Going to Market . . . . . i.	534
7. Valley of Jehoshaphat . . . . . iii.	1583	30. Group of Lepers Begging . . . . . iii.	1867
VARIOUS FORMS OF EGYPTIAN HARPS . . . . . iii.	2099	31. Heights behind Masada . . . . . ii.	809
VEHICLES—		32. The Jabbok . . . . . iii.	1546
1. Assyrian Chariot . . . . . i.	596	33. Jebel Usdum from the South, Looking over the Mud Flat Covered by the Sea at High Water . . . . . ii.	801
2. Assyrian King in His Chariot . . . . . i.	292	34. Magdala . . . . . iii.	1962
3. Egyptian Cart . . . . . i.	581	35. Market-place at Jaffa . . . . . i.	533
4. Egyptian War Chariot . . . . . i.	595	36. Mizpah . . . . . iii.	2069
5. Litter . . . . . iii.	1905	37. Mound Covering Nippur Tower . . . . . i.	349
6. Modern Cart . . . . . i.	581	38. Mount of Olives from the Golden Gate . . . . . iv.	2187
7. Philistine Wagons . . . . . iv.	2378	39. Mount of Olives Overlooking the Dead Sea (Full Page) . . . . . ii.	802
8. Sargon in His War Chariot . . . . . iv.	2693	40. Naphtali . . . . . iv.	2119
VENDOR OF WATER, A (Full Page) . . . . . v.	3074	41. Nazareth, from the Road to the Plain of Esdraelon . . . . . iv.	2124
VIEW FROM AIN JIDY, LOOKING SOUTH . . . . . ii.	808	42. Part of Rock of Behistun . . . . . iv.	2329
VIEW FROM THE HEIGHTS BEHIND MASADA . . . . . ii.	809	43. Pass of Michmash . . . . . iii.	2048
VIEW FROM MOUNT OF OLIVES OVERLOOK- ING THE DEAD SEA (Full Page) . . . . . ii.	802	44. Plain of Sharon . . . . . iv.	2751
VIEW FROM TOP OF MOUNT SINAI (Full Page) . . . . . iv.	2802	45. Pool of Bethesda . . . . . i.	445
VIEWS OF BIBLE LANDS—		46. Rock of Masada . . . . . iv.	2788
1. Abana River . . . . . ii.	779	47. Ruined Church at Kuriet . . . . . iii.	1812
2. Ain Jidy, Looking South . . . . . ii.	808	48. Ruins of Ancient Corinth with Acro- Corinthus in the Background . . . . . ii.	711
3. Anathoth, Jeremiah's Birthplace (Full Page) . . . . . iii.	1588	49. Ruins of Eleusis . . . . . ii.	1303
4. Arches of Ancient Aqueduct at An- tioch (Full Page) . . . . . i.	658	50. Ruins in Samaria . . . . . iv.	2671
5. Bank of the Nile . . . . . iv.	2145	51. Safed and Jebel Jermuk . . . . . v.	3006
6. Bazaar at Jaffa . . . . . iii.	1995	52. Sea of Galilee . . . . . ii.	1165
7. Beersheba, Overlooking the Desert (Full Page) . . . . . i.	424	53. Series of Baths in the Castle at Gezer . . . . . i.	415
8. Bethany . . . . . i.	442	54. The Shepherd's Field and Field of Boaz . . . . . i.	450
9. Bethel . . . . . i.	444	55. Site of Ancient Jericho . . . . . iii.	1592
10. Bethphage . . . . . i.	451	56. Slope of Zion—Tyropoeon Valley at Right . . . . . v.	3151
		57. Stone in Quarries at Baalbek . . . . . iv.	2513
		58. Sunrise over the Sea of Galilee (Full Page) . . . . . ii.	1166
		59. Tell Hum—Traditional Capernaum (Full Page) . . . . . i.	567
		60. Tell Taanach . . . . . iii.	1390

61. Through the Rocks at Joppa . . . . . iii. 1732  
 62. Tiberias . . . . . v. 2978  
 63. Traditional Megiddo—Ruins of Palace and Public Buildings (Full Page) . . . . . iii. 2028  
 64. Traditional Site of Brook Cherith . . . i. 603  
 65. Tyre . . . . . v. 3030  
 66. "Up to Jerusalem" from the Inn of the Good Samaritan . . . . . iv. 2122  
 67. View from Top of Mount Sinai (Full Page) . . . . . iv. 2802  
 68. Wadi-ul-Ain (Presumed Site of Gerar) . . . . . i. 524  
 69. Waters of Merom . . . . . iii. 2037  
 70. Wilderness of Judaea . . . . . iii. 1757  
 71. Wilderness of Judaea . . . . . v. 3064  
 72. Yezdikhast . . . . . iv. 2330  
 73. Young Camels Grazing . . . . . i. 547  
 VIRGIN'S FOUNT, THE . . . . . ii. 1229  
 VOTIVE OFFERING . . . . . ii. 1302  
 WADI-UL-AIN (PRESUMED SITE OF GERAR) . . i. 524  
 WALLS OF TELL EJ JUDEIDEH . . . . . i. 664  
 WAR—  
 1. Assyrian Armed Galley in Motion . . iv. 2775  
 2. Assyrian King Placing His Foot on the Neck of an Enemy . . . . . ii. 1126  
 3. Assyrian Standards and Banners . . . i. 384  
 4. Bas-relief of Sennacherib Besieging Lachish . . . . . iv. 2150  
 5. Battering-ram . . . . . iv. 2787  
 6. Battle-axes and Spears . . . . . i. 252  
 7. Bows, Arrows and Quiver . . . . . i. 252  
 8. Breastplate . . . . . i. 253  
 9. Catapult for Hurling Missiles . . . . iv. 2788  
 10. Egyptian Slinger . . . . . i. 252  
 11. Egyptian Standards . . . . . i. 384  
 12. Egyptian Swords . . . . . i. 252  
 13. Egyptian War Chariot . . . . . i. 595  
 14. Greaves and Sandals . . . . . i. 254  
 15. Group of Ancient Arms . . . . . i. 251  
 16. Heavy-armed Greek Soldier . . . . . i. 251  
 17. Helmet . . . . . i. 253  
 18. Hittite Warrior—Boghaz-keuy . . . . i. 278  
 19. Hittite Warrior—Senjirli . . . . . iii. 1400  
 20. Loopholes through Which Arrows Were Shot . . . . . iv. 2765  
 21. Persian Warriors . . . . . iv. 2336  
 22. Roman Standards or Banners . . . . . v. 3070  
 23. Sargon in His War Chariot . . . . . iv. 2693  
 24. Shield, Sword, and Girdle . . . . . i. 253  
 25. Siege of a City . . . . . ii. 1139  
 26. A Subject People Paying Tribute . . . v. 3011  
 WARNING TABLET OF HEROD'S TEMPLE . . iv. 2254  
 WASHING BEFORE EATING . . . . . i. 412  
 WATER CARRIERS WITH SKIN BOTTLES . . . i. 510  
 WATERS OF MEROM . . . . . iii. 2037  
 WATER-SUPPLY (OF JERUSALEM), THE . . . . iii. 1609  
 WATER WHEEL ON RIVER ORONTES AT ANTIOCH (Full Page) . . . . . i. 158  
 WEAVING—  
 1. Showing "Shed" of Arab Loom . . . . v. 3078  
 2. Showing Upright Loom . . . . . v. 3078  
 3. Spindles . . . . . v. 2841  
 4. The Spinning Woman . . . . . ii. 922  
 5. Weaving (Figure 1) . . . . . v. 3077  
 6. Weaving (Figure 2) . . . . . v. 3077  
 WEIGHTS AND MEASURES—  
 1. Assyrian Balance . . . . . i. 380  
 2. Balance (from Egyptian Tomb) . . . . i. 380  
 3. Bronze and Stone Weights Used in Nineveh . . . . . v. 3079  
 4. Weights of Phoenician Standard . . . v. 3080  
 WELL OF ABRAHAM AT BEERSHEBA (Full Page) . . . . . i. 18  
 WELLS, RESERVOIRS AND FOUNTAINS—  
 1. Ancient Aqueduct at Smyrna . . . . . iv. 2818  
 2. Arches of Ancient Aqueduct at Antioch (Full Page) . . . . . i. 658  
 3. Fountain at Askar . . . . . v. 2876  
 4. The Fountain at Khan Minyeh . . . . i. 567  
 5. "Gideon's Fountain" in the Plain of Esdraelon . . . . . ii. 993  
 6. Jacob's Well . . . . . iii. 1556  
 7. Plan of the Baths in the Castle at Gezer . . . . . i. 414  
 8. Pool of Bethesda . . . . . i. 445  
 9. Pool of Hezekiah . . . . . iii. 1386  
 10. Pools of Solomon . . . . . i. 659  
 11. Reservoir at Gezer . . . . . i. 658  
 12. Rock-cut Aqueduct . . . . . i. 659  
 13. St. Mary's Well at Nazareth . . . . . ii. 874  
 14. Series of Baths in the Castle at Gezer . i. 415  
 15. Serpentine Course of Siloam Aqueduct . . . . . iv. 2791  
 16. The Virgin's Fount . . . . . ii. 1229  
 17. The Water-supply (of Jerusalem) . . . iii. 1609  
 18. Well of Abraham at Beersheba (Full Page) . . . . . i. 18  
 WILDERNESS OF JUDAEA . . . . . iii. 1757  
 WILDERNESS OF JUDAEA . . . . . v. 3064  
 WILD GOAT OF SINAI . . . . . ii. 1249  
 WINDOW . . . . . iii. 1436  
 WOLF . . . . . v. 3099  
 WOMAN'S HEADRESS AND VEIL (MODERN) . ii. 877  
 WOMEN AT A MODERN MILL . . . . . iii. 2032  
 WORD-SIGNS USED BY TEWA INDIANS . . . . v. 3118  
 WORMWOOD . . . . . v. 3109  
 WORSHIPPING HEAVENLY BODIES . . . . . i. 370  
 WORSHIPPING THE LUNAR DEITY . . . . . i. 371  
 WRITER, HIS PALETTE, AND A PYPYRUS LEAF, A . . . . . i. 496  
 WRITING—  
 1. Aramaic, Greek and Latin Writing in Common Use in Palestine in Gospel Times . . . . . v. 3125  
 2. Ancient Manuscripts on Papyrus (Insert) . . . . . ii. 2238  
 3. Asshur-bani-pal's Account of His Restoration of the Stage-tower at Nippur . . . . . i. 294  
 4. Assyrian Book . . . . . i. 497  
 5. Boundary Stone of Nebuchadrezzar I . . . . . iv. 2128

6. Brick Stamp of Sargon I. . . . . i. 361  
7. Building Inscription of Nabopolassar i. 356  
8. Building Inscription of Nebuchad-  
rezzar II. . . . . i. 349  
9. Clay Tablet with Seal Inscription. . . . . i. 364  
10. Code of Hammurabi (Insert). . . . . iii. 1854  
11. Common Egyptian Writing during  
the Bondage. . . . . v. 3125  
12. Common Egyptian Writing in the  
Time of Abraham. . . . . v. 3124  
13. Cuneiform Tablet from Boghaz-keuy i. 281  
14. The Deluge Tablet. . . . . i. 374  
15. Egyptian Roll and Case. . . . . iv. 2597  
16. From an Engraving on a Babylonian  
Cylinder Representing the Sun  
God and One of His Priests. . . . . i. 371  
17. Facsimile of Codex Ephraemi Re-  
scriptus. . . . . v. 2953  
18. Facsimile of Codex Sinaiticus. . . . . v. 2951  
19. Facsimile Minuscule Manuscript. . . . . v. 2954  
20. Fragments of Inscribed Vases of the  
Early Sumerian Period. . . . . i. 360  
21. Greek Papyrus Containing Matthew  
1:1-9, 12, 13, 14-20. . . . . iv. 2241  
22. Hebrew Inscribed Tablet from Gezer. i. 105  
23. Hieroglyphic Writing. . . . . v. 3118  
24. Impression of a Seal Cylinder. . . . . i. 291  
25. Ink-wells and Pen-case with Ink-  
well. . . . . iii. 1469  
26. Inscribed Tablet Impressed with  
Seals. . . . . iv. 2152  
27. Inscription and Mutilated Figure  
from Jerabis. . . . . iii. 1401  
28. The Installation of Umman-igas. . . . . ii. 920  
29. "Israel" Stele in Museum at Cairo  
(Full Page). . . . . iii. 1516  
30. Jewish Mnemonic Fringes. . . . . v. 3117  
31. Last Stand of Te-umman. . . . . ii. 921  
32. Letter from the Governor of Jerusa-  
lem about 1375 BC. . . . . v. 3120  
33. Message Sticks. . . . . v. 3116  
34. Moabite Stone. . . . . iii. 2071  
35. Modern Egyptian Writing Mate-  
rials. . . . . v. 3119  
36. New Sayings of Jesus. . . . . iv. 2241  
37. Niches and Tablets at Banias (Full  
Page). . . . . i. 536  
38. Ostrakon with Luke 22:70 f. . . . . iv. 2203  
39. The Paestos Disk, Face A. . . . . i. 104  
40. *Papyrus Antiquorum*. . . . . iv. 2239  
41. Presentation of Umman-igas to His  
Subjects by the Assyrian General. . . . . ii. 921  
42. Primitive Alphabets (Insert). . . . . i. 104  
43. Primitive Sigus Like A. . . . . i. 104  
44. The Quipu. . . . . v. 3117  
45. A Reader with a Roll. . . . . i. 499  
46. Samaritan High Priest with Scroll. . . . . iv. 2313  
47. Scribe's Palette. . . . . iii. 1469  
48. Scribes with Utensils. . . . . v. 3123  
49. Seal Cylinders. . . . . i. 363  
50. Section of Codex Washingtoniensis—  
Mark 1:1-7 (Insert). . . . . v. 2952  
51. Sigus of the Cave-dwellers. . . . . v. 3121  
52. Siloam Inscription—Writing at Jeru-  
salem at the Time of Hezekiah. . . . . v. 3120  
53. Stone Object Containing an Inscrip-  
tion of Nebuchadrezzar I. . . . . i. 353  
54. Table Showing Script of Semitic  
Languages. . . . . iv. 2314  
55. Terra-cotta Cylinder Containing the  
History of the Capture of Babylon  
by Cyrus the Great. . . . . i. 575  
56. Text of the Code of Hammurabi. . . . . ii. 1329  
57. Timotheus Papyrus. . . . . iv. 2240  
58. Title on the Cross. . . . . v. 2988  
59. Warning Tablet of Herod's Temple. . . . . iv. 2254  
60. Word-signs Used by Tewa Indians. . . . . v. 3118  
61. Worshipping Heavenly Bodies. . . . . i. 370  
62. Worshipping the Lunar Deity. . . . . i. 371  
63. A Writer, His Palette, and a Papyrus  
Leaf. . . . . i. 496  
YEZDIKHAŠT. . . . . iv. 2330  
YOKE OF ANCIENT PLOW. . . . . v. 3126  
YOUNG CAMELS GRAZING. . . . . i. 547  
ZEUS FROM MYLASA. . . . . ii. 1297

# INDEX TO THE ATLAS OF THE LANDS OF THE BIBLE

## LIST OF MAPS

- |   |   |
|---|---|
| <ol style="list-style-type: none"> <li>1. The Ancient World and the Descendants of Noah</li> <li>2. Sinai and Palestine, Showing Israel's Journeys through the Desert</li> <li>3. Canaan at the Time of the Conquest</li> <li>4. Canaan as Divided among the Twelve Tribes</li> <li>5. Babylonian Empire</li> <li>6. Persian Empire</li> <li>7. Grecian Empire</li> </ol> | <ol style="list-style-type: none"> <li>8. Roman Empire</li> <li>9. The Dominions of David and Solomon</li> <li>10. The Kingdoms of Judah and Israel</li> <li>11. Palestine in the Times of the New Testament</li> <li>12. Missionary Journeys of St. Paul</li> <li>13. Environs of Jerusalem</li> <li>14. Galilee</li> <li>15. Ancient Jerusalem</li> <li>16. Modern Jerusalem</li> </ol> |
|---|---|

## ALPHABETICAL LIST OF BIBLICAL PLACE-NAMES PROPERLY LOCATED BY MAP NUMBER FOLLOWED BY KEY NUMERALS AND LETTERS

NOTE.—Numerals following place-name preceding dash (—) denote the map number. The numeral and letter following the dash indicate the location of the name on the map; thus, Abana River . . . 4, 10, 11—6A; 9—4F, appears on maps 4, 10, and 11 at space 6A and also on map 9 at space 4F.

- | A  |  |
|--|--|
| <p>Abana River . . . . . 4, 10, 11—6A; 9—4F</p> <p>Abdon . . . . . 4—3C</p> <p>Abedije . . . . . 14—5G</p> <p>Abel-beth-maacah . . . . . 4, 10, 11—4C; 9—4F</p> <p>Abel-meholah . . . . . 4, 10—4F</p> <p>Abel-shittim . . . . . 3, 4—4H</p> <p>Abez . . . . . 4—3E</p> <p>Abiad, Wady el . . . . . 2—5E</p> <p>Abila . . . . . 11—5E</p> <p>Abilene . . . . . 11—5A</p> <p>Abimael . . . . . 1—7F</p> <p>Absalom, Tomb of . . . . . 15—5D</p> <p>Abu Dis . . . . . 13—4F</p> <p>Abu el Hamam, Wady . . . . . 13—3L</p> <p>Abu esh Sheba, Kh. . . . . 14—3B</p> <p>Abumudaubar . . . . . 14—7J</p> <p>Abu Said, Wady . . . . . 14—6N</p> <p>Abu Shusheh, Kh. . . . . 14—4C</p> <p>Abyssinian Church . . . . . 16—1A</p> <p>Accad . . . . . 1—6D</p> <p>Acco, see Ptolemais . . . . . 3, 4, 10, 11—3D; 2—6A; 9—3G</p> <p>Achaia . . . . . 8, 12—4C</p> <p>Achor, Valley of . . . . . 13—6D</p> <p>Achshaph . . . . . 4—3D</p> <p>Achzib (Ecdippa) . . . . . 3, 4, 11—3C</p> <p>Acra . . . . . 15—3C</p> <p>Adam . . . . . 4—4G</p> <p>Adamah . . . . . 4—4E; 11—4C</p> <p>Adamah (Damieh) . . . . . 14—4F</p> <p>Adamah, see Adami . . . . . 14—5H</p> <p>Adami . . . . . 4—4E</p> <p>Adami (Adamah) . . . . . 14—5H</p> <p>Adasa (Adaseh) . . . . . 13—3D</p> <p>Adaseh, see Adasa . . . . . 13—3D</p> <p>Adjlun, Wady . . . . . 11—4G</p> | <p>Adoraim . . . . . 4—3J</p> <p>Adramyttium . . . . . 12—6C</p> <p>Adriatic Sea . . . . . 12—3A</p> <p>Adullam . . . . . 4, 10—3J; 3—2I</p> <p>Adummim . . . . . 4—3H; 13—5E</p> <p>Aegyptus . . . . . 8—5E</p> <p>Africa . . . . . 8—3E</p> <p>Agrippa, Palace of . . . . . 15—4D</p> <p>Ahlab . . . . . 4—4C</p> <p>Ahmar, Kh. el . . . . . 13—5E; 14—4M</p> <p>Ai . . . . . 3, 4, 10, 11—3H; 2—6C</p> <p>Ai, Hai, Aiath (Kh. Haiyan). 13—4C</p> <p>Aijalon . . . . . 4—3H</p> <p>Aijalon, Valley of . . . . . 3—1B; 3—2H</p> <p>Ailbun . . . . . 14—3D</p> <p>Ain, Wady el . . . . . 2—4F</p> <p>Ain 'Arik, Wady . . . . . 3—2A</p> <p>Ain Atan . . . . . 13—2H</p> <p>Ain ed Duk, see Docus . . . . . 13—6C</p> <p>Ain el Feshkhal . . . . . 13—7G</p> <p>Ain el Ghuweir . . . . . 13—7J</p> <p>Ain el Kuderat . . . . . 2—4F</p> <p>Ain el Kuseimeh . . . . . 2—4F</p> <p>Ain el Mudauwerah . . . . . 14—4D</p> <p>Ain el-Muweileh (Hagar's Well) . . . . . 2—4F</p> <p>Ain el Weibeh (Kadesh?) . . . . . 2—6F</p> <p>Ain et Tannur . . . . . 13—7G</p> <p>Ain et Tineh . . . . . 14—5C</p> <p>Ain et Trabeh . . . . . 13—7J</p> <p>Ain Haud, see En Shemesh. 13—4F</p> <p>Ain Jalud, see Well of Harod 14—2K</p> <p>Ain Kadeis (Kadesh) . . . . . 2—4F</p> <p>Ain Kana . . . . . 14—1F</p> <p>Ain Karim, see Beth-car? . . . . . 13—2F</p> <p>Ain Mahil, see Nahallal . . . . . 14—2F</p> |



- Ain Sha'in?, see Shihon . . . 14-2F  
 Ain Sinia . . . 13-3A  
 Ain Tubaun, see Tubania . . . 14-2K  
 Ain Yebrud . . . 13-4B  
 Aisawiyeh . . . 13-4E  
 Aiya . . . 11-4C  
 Ajalon . . . 4-3E; 10-3H  
 Akabah, Gulf of . . . 2-5J  
 Akbara . . . 14-4A  
 Akrabbim . . . 4-4M  
 Aksa . . . 16-5C  
 Akur . . . 13-1F  
 Alemeth, Almon . . . 13-4E  
 Aleppo . . . 9-5B  
 Alexandria . . . 6, 7-2C; 7-6A and 5C; 12-8G  
 Almodad . . . 1-6F  
 Aloth . . . 10-3C  
 Alush? . . . 2-4J  
 Alya, Wady . . . 13-4H  
 Amad . . . 4-3C  
 Amalekites . . . 2-4I  
 Amatha . . . 11-4E  
 Ammon . . . 4, 10, 11-5G  
 Ammonites . . . 3-6H; 9-5I  
 Ammonium . . . 7-2C  
 Amorites . . . 2-6D  
 Amphipolis . . . 12-5B  
 Amud, Wady el . . . 14-4C and 7K  
 Amwas, see Emmaus . . . 11-2H  
 Amygdalon, Pool of . . . 15-3C  
 Anab . . . 4-2K  
 Anaharath . . . 4-4E  
 Anaharath? (en Naurah) . . . 14-3J  
 Anamim . . . 1-4E  
 Ananiah . . . 13-3E  
 Anata, see Anathoth . . . 13-4E  
 Anathoth . . . 10-3H  
 Anathoth (Anata) . . . 13-4E  
 Ancient Road . . . 3-1B  
 Ancyra . . . 12-9B  
 Anem . . . 4-3F  
 Anim . . . 4-3K  
 Anti-Lebanon . . . 4, 11-5A  
 Antioch . . . 7-3C; 9-4B; 12-8C and 10D  
 Antiochia . . . 8-5D  
 Antipatris . . . 11-2G  
 Antonia Praetorium . . . 15-4B  
 Antonia, Tower of . . . 16-4B  
 Apek . . . 3, 4-5E; 9-4G; 10-5D  
 Apollonia . . . 11-2G; 12-5B and 5G  
 Appenine Mts. . . . 12-2B  
 Appii Forum . . . 12-1A  
 Arabah, Wady el . . . 2-6F  
 Arabia . . . 5, 6, 7-4D; 1, 8-6E  
 Arabian Gulf . . . 6-3D  
 Arabian Sea . . . 1-5E  
 Arab Protestant Church . . . 16-2A  
 Arab, Wady el . . . 14-6J  
 Arad . . . 3, 4, 10, 11-2K; 9-3I  
 Aral Sea . . . 1-7C  
 Aram . . . 1-6D  
 Aram or Syria . . . 9-6D  
 Araxes River . . . 6-4B  
 Arbela . . . 11-4E and 6E  
 Arbela (Irbid) . . . 14-4D  
 Archi . . . 4-3H; 13-2C  
 Archipelago . . . 12-6C  
 Argob . . . 3, 10-7C; 4-6D; 9-5F  
 Ariana . . . 6-6C; 7-6B  
 'Arish, Wady el (River of Egypt) . . . 2-4E  
 Armenia . . . 5, 6, 7-4B; 8-6C  
 Armenian Convent . . . 16-3D  
 Armenian Quarter . . . 16-3D  
 Ar-moab . . . 4, 10-4K; 9-4I  
 Arnon River . . . 3, 10-5J; 2-7D; 4-4K; 9-4I  
 Arnon River, see Wady el Mojib . . . 11-5K  
 Aroer . . . 2-7D; 3-5J; 4-5K and 2L; 9-3I and 4I; 10-5J; 11-2L, 5H and 5K  
 Ar of Moab . . . 3-5J  
 Arphaxad . . . 1-6E  
 Ar (Rabbath-moab) . . . 11-5K  
 Arrabet el Buttauf . . . 14-2C  
 Arrub, Wady el . . . 13-3J  
 Arvad . . . 9-4D  
 Ascension, Church of the . . . 16-7C  
 Ashdod . . . 3-II; 4-1H; 10-2H  
 Ashdod (Azotus) . . . 11-1J  
 Asher . . . 4-3C  
 Ashik, Kh. el . . . 14-7E  
 Ashkelon . . . 4, 11-1J; 3-II; 10-1H  
 Ashkenaz . . . 1-6D  
 Ashtaroth . . . 3-5E  
 Ashtaroth-karnaim . . . 3, 4, 10-6D  
 Asia . . . 8-5D; 12-7C  
 Asochis, Plain of (Sahel el Buttauf) . . . 14-2D  
 Asshur . . . 1-6D  
 Assos . . . 12-6C  
 Assyria . . . 5-4B; 7-4C  
 Assyrians, Camp of the . . . 15-2C  
 Ataroth . . . 3-4I; 4-3H  
 Atharoth . . . 11-3H  
 Athens . . . 12-5D  
 Attalia . . . 12-8D  
 Attara, see Baal Tamar . . . 13-3C  
 Audjeh River . . . 11-2G  
 Aujeh, el . . . 2-5E  
 Aulam . . . 14-4G  
 Auranitis . . . 11-6C  
 Austrian Hospice . . . 16-4B  
 Auwad . . . 3-1B  
 Auwaj, Wady el . . . 13-5F

- Awanish, el . . . . . 14—7D  
 Azekah . . . . . 3—2I; 4—2J  
 Aziriyeh, see Bethany . . . . . 13—4F  
 Azmaveth (Hizme) . . . . . 13—4D  
 Azotus?, Mount (Birez Zeit) . . . . . 13—3A  
 Azotus, see Ashdod . . . . . 11—1J
- B
- Baalath . . . . . 3—1A; 13—1B  
 Baalbek . . . . . 9—4E  
 Baal-gad . . . . . 4—5C  
 Baal-hazor (Teli Asur) . . . . . 13—4A  
 Baal-meon . . . . . 4—4J; 11—5J  
 Baal-shalisha . . . . . 10—3G  
 Baal Tamar (Attara) . . . . . 13—3C  
 Baal Zephon . . . . . 2—2F  
 Babel . . . . . 1—6D  
 Babylon . . . . . 5, 7—4C  
 Babylonia . . . . . 5, 6, 7—4C  
 Babylonian Empire . . . . . 5—4C; 6—3C  
 Bactriana . . . . . 6, 7—6B  
 Bahr Lut, see Dead Sea . . . . . 13—7K  
 Bahr Tubariya, see Lake of  
   Tiberias . . . . . 14—6E  
 Bamoth-baal . . . . . 4—4J  
 Barium . . . . . 12—2B  
 Barrack . . . . . 16—3D  
 Bashan . . . . . 3—6D; 4—5C; 10—  
   6C  
 Bashan, Conquest of . . . . . 3—5E  
 Bashan, Hills of . . . . . 9—5G  
 Bassas, Wady . . . . . 13—4K  
 Beeroth . . . . . 3, 4—3H  
 Beeroth (Birch) . . . . . 13—3C  
 Beersheba . . . . . 3, 4, 10, 11—2K; 2—  
   5E; 9—3I  
 Beisan, see Beth-shean . . . . . 14—4M  
 Beit Ainun, Kh., see Beth-  
   anath . . . . . 13—2K  
 Beit Anan . . . . . 13—2D  
 Beit Fejjar . . . . . 13—2J  
 Beit Hannina, Wady . . . . . 13—3E  
 Beit Iksa . . . . . 13—3E  
 Beitin, see Bethel, Luz . . . . . 13—4B  
 Beit Izza . . . . . 13—2D  
 Beit Jala, see Gallim . . . . . 13—3G  
 Beit Jubr . . . . . 13—7D  
 Beit Lahm, see Bethlehem . . . . . 13—3G  
 Beit Likia . . . . . 3—1C; 13—1D  
 Beit Mizza, Kh., see Mozah . . . . . 13—2E  
 Beit Sahar . . . . . 13—3G  
 Beit Skaria, Kh., see Beth-  
   zacharias . . . . . 13—2H  
 Beit Sufafa . . . . . 13—3F  
 Beit-sur, see Beth-zur . . . . . 13—1K  
 Beit Surik . . . . . 13—2E  
 Beit Tamir . . . . . 13—3H  
 Beit Tul, see Jethlah . . . . . 13—1E  
 Beitunia . . . . . 13—2C  
 Beit Ur el Foka . . . . . 3—2B  
 Beit Ur et Tahta . . . . . 3—2B  
 Belus River . . . . . 11—3D  
 Bene-berak . . . . . 4—2G  
 Beni Naim, see Janum . . . . . 13—2I  
 Benjamin . . . . . 4—3H  
 Beracah, Valley of . . . . . 13—2J  
 Berea . . . . . 12—5B  
 Bered . . . . . 9—3I  
 Berenice . . . . . 12—3G  
 Berothah . . . . . 9—3E  
 Berytus . . . . . 12—10F  
 Bethabara . . . . . 11—4H  
 Bethabara?   Beth-barah  
   (Makht Abarah) . . . . . 14—5K  
 Beth-anath . . . . . 4—4C  
 Beth-anoth . . . . . 4—3J  
 Beth-anoth (Kh. Beit Ainun) . . . . . 13—2K  
 Bethany . . . . . 11—3H  
 Bethany (Aziriyeh) . . . . . 13—4F  
 Beth-baal-meon . . . . . 3—5I  
 Beth-barah . . . . . 4—4E  
 Beth-barah,   Bethabara?  
   (Makht Abarah) . . . . . 14—5K  
 Beth-car? (Ain Karim) . . . . . 13—2F  
 Beth-dagon . . . . . 4—2H  
 Bethel . . . . . 3, 4, 9, 10 11—3H;  
   2—6C  
 Bethel, Luz (Beitin) . . . . . 13—4B  
 Bether (Bittir) . . . . . 13—2G  
 Bethesda, Pool of . . . . . 16—5B  
 Beth-haran . . . . . 3, 4—4H  
 Beth-hoglah . . . . . 4, 11—4H  
 Beth-horon . . . . . 3, 11—3H; 3—2B  
 Beth-horon and Vicinity . . . . . 3—2B  
 Beth-jeshimoth . . . . . 3, 4—4H  
 Bethlehem . . . . . 4, 11—3J; 9, 10—3H;  
   4—3E; 12—10G;  
   2—6D  
 Bethlehem (Beit Lahm) . . . . . 13—3G  
 Beth-nimrah . . . . . 3, 4, 11—4H  
 Bethphage . . . . . 11—3H  
 Bethphage? (Kefr et Tor) . . . . . 13—4F  
 Beth-rehob . . . . . 3, 4—4C; 2—7A  
 Bethsaida . . . . . 11—4D  
 Bethsaida-Julias . . . . . 11—5D; 14—6B  
 Beth-shean . . . . . 3, 4—4F; 9—4G; 10  
   —4E  
 Beth-shean (Beisan) . . . . . 14—4N  
 Beth-shemesh . . . . . 4, 10—2H; 11—4D  
 Beth-shittah . . . . . 4—4E  
 Beth-shittah (Shutta) . . . . . 14—3K  
 Beth-tappuah . . . . . 4—3J  
 Beth-zacharias (Kh. Beit  
   Skaria) . . . . . 13—2H  
 Beth-zur . . . . . 4, 10—3J  
 Beth-zur (Beit-sur) . . . . . 13—1K  
 Betonim . . . . . 3—4H  
 Betsaanim? (Sabel el Ahma) . . . . . 14—4F  
 Bezek . . . . . 4, 11—4F; 3—2H  
 Bezer . . . . . 3—5J; 4—4K; 9—4I  
 Bezetha . . . . . 16—4B  
 Biar, Wady el . . . . . 13—2H  
 Bileam . . . . . 4—3F  
 Bileam or Ibleam . . . . . 3—3F

Bireh, see Beeroth. . . . . 13—3C  
 Bireh, Wady el. . . . . 14—5J  
 Birein, el. . . . . 2—5F  
 Bir-es Sak. . . . . 13—5F  
 Bir ez Zeit, see Mt. Azotus? . 13—3A  
 Birket es Sultan. . . . . 16—2E  
 Birket Mamila. . . . . 16—1C  
 Bir Nebala. . . . . 13—3D  
 Bithynia. . . . . 6, 7—2B; 8—5C; 12—8B  
 Bittir, see Bether. . . . . 13—2G  
 Biyar Mayein. . . . . 2—5F  
 Black Sea. . . . . 1—5C; 6—3A; 12—9A  
 Boeotia. . . . . 8—4C  
 Bohan, Stone of. . . . . 13—7F  
 Bosphorus. . . . . 6—2B; 12—7A  
 Boundary Line between Turkey and Egypt. . . . . 2—5F  
 Bozkath. . . . . 4—2J  
 Bozrah. . . . . 2, 10—7E; 4, 11—4M; 3—7F; 9—4J  
 Breikut, Kh. . . . . 13—2J  
 Breka. . . . . 14—7F  
 Britannia. . . . . 8—2A  
 Brook Besor. . . . . 11—1K  
 Brundisium. . . . . 12—3B  
 Brusa. . . . . 12—7B  
 Bukeia, el. . . . . 13—6G  
 Burak, el. . . . . 13—2H  
 Burkah. . . . . 13—4C  
 Byblos, see Gebal. . . . . 9—4C  
 Byzantium, see Constantinople. . . . . 12—7B

C

Cabbon. . . . . 4—2J  
 Cabul. . . . . 4, 10—3D; 9—3G; 11—4C  
 Cabura. . . . . 7—6C  
 Caesarea. . . . . 11—2F; 12—10C and 10F  
 Caesarea Philippi. . . . . 11—4C  
 Caiaphas, House of. . . . . 16—3E  
 Cain. . . . . 4—3K  
 Calah. . . . . 1—6D  
 Callirhoe. . . . . 11—4J  
 Calneh. . . . . 1—6D  
 Calvary? . . . . . 15—4A  
 Cana. . . . . 11—3E  
 Cana? (Kh. Kana). . . . . 14—1D  
 Cana of Galilee (Kefr Kenna) . 14—2F  
 Canaan. . . . . 1—5D; 2—6C  
 Canaanites. . . . . 2—6B; 3—3D and 4G  
 Capernaum. . . . . 11—4D  
 Capernaum (Kh. Minieh). . . . 14—5C  
 Caphtorim. . . . . 1—4D  
 Cappadocia. . . . . 6, 7—3B; 8—5C; 12—10C  
 Carchemish. . . . . 5—3B  
 Caria. . . . . 6, 7—2B; 12—7D  
 Carmania. . . . . 6, 7—5D

Carmel. . . . . 4, 11—3K; 9—3I  
 Carmel, Mount. . . . . 3, 4, 11—2D; 9—3G; 10—3D  
 Carmelites' Convent. . . . . 16—7C  
 Carthage. . . . . 8—3D  
 Casluhim. . . . . 1—5E  
 Caspian Sea. . . . . 1—7D; 6—4B  
 Caucasus, Mount. . . . . 6—4B  
 Cedron or Kidron, Brook (Wady en Nar). . . . . 13—5G  
 Central Campaign. . . . . 3—3G  
 Chephar-hammon-ai? (Kefr Ana). . . . . 13—4B  
 Chephirah. . . . . 3, 4—3H  
 Chephirah (Kefreh). . . . . 13—1E  
 Chesalon. . . . . 4—3H  
 Chesulloth. . . . . 4—3E  
 Chesulloth (Iksal). . . . . 14—1G  
 Chinnereth. . . . . 11—4E  
 Chinnereth, Sea of. . . . . 4, 10—4D; 2—7A; 3—4E; 9—4G; 14—6D  
 Chios. . . . . 12—6C  
 Chorazin. . . . . 11—4D  
 Chorazin (Kerazeh). . . . . 14—5B  
 Chozeba (Kh. Kueiziba). . . . 13—2K  
 Christian Cemetery. . . . . 16—3E  
 Church of the Tomb of the Virgin. . . . . 16—6B  
 Cilicia. . . . . 6, 7—3B; 8—5D; 12—10D  
 Citadel. . . . . 15—2D  
 Claudia. . . . . 12—5E  
 Cnidus. . . . . 12—7D  
 Colossae. . . . . 12—7D  
 Conquest of Bashan. . . . . 3—5E  
 Conquest of Gilead. . . . . 3—5I  
 Constantinople (Byzantium) . 12—7B  
 Corinth. . . . . 12—5D  
 Cos. . . . . 12—6D  
 Crete. . . . . 7—2B; 8—4D; 12—5E  
 Cush. . . . . 1—5F and 6E  
 Cyprus. . . . . 6—2C; 8—5D; 9—1D; 12—9E  
 Cyrene. . . . . 12—4G

D

Daberath. . . . . 4—3E  
 Daberath (Deburich). . . . . 14—2G  
 Dacia. . . . . 8—4B  
 Damascus. . . . . 4, 11—6A; 5—3B; 6—3C; 9—4F; 10—7A; 12—10F  
 Damascus Gate. . . . . 16—3B  
 Damieh, see Adamah. . . . . 14—4F  
 Damietta. . . . . 2—1D  
 Dan. . . . . 4, 10—5B; 4—2H and 3C; 9—4F; 11—4C; 12—10F  
 Dan or Laish. . . . . 3—4B; 4—5B  
 Daphne. . . . . 12—10D

Dar el Jerir, Wady . . . . . 13—5B  
 David Street . . . . . 16—3C  
 David's Tomb . . . . . 15—3C; 16—3E  
 Dead Sea (Bahr Lut), see  
 Salt Sea . . . . . 11—4K; 12—10G; 13—7K  
 Debir . . . . . 4, 11—2K; 3—2J; 13—5E  
 Deburieh, see Daberath . . . . . 14—2G  
 Decapolis . . . . . 11—5E  
 Dedan . . . . . 1—5E  
 Deir Diwan . . . . . 13—4C  
 Deir esh Sheikh . . . . . 13—1F  
 Deir Hanna . . . . . 14—2C  
 Deir Hassan, Kh. . . . . 3—2A  
 Deir Izbzia . . . . . 13—2C  
 Deir Yesin . . . . . 13—3F  
 Dekakin, Wady ed. . . . . 13—5F  
 Denna . . . . . 14—4H  
 Derajeh, Wady ed. . . . . 13—6K  
 Derbe . . . . . 12—9D  
 Derb el Hajj or Pilgrim  
 Route to Mecca . . . . . 2—4H  
 Dibon . . . . . 4, 11—5K; 2—7D; 10—5J  
 Dibon, or Dimon . . . . . 3—5J  
 Diklah . . . . . 1—6F  
 Dimon or Dibon . . . . . 3—5J  
 Dium or Dieu, see Eidun . . . . . 3—5E  
 Docus (Ain ed Duk) . . . . . 13—6C  
 Dodanim . . . . . 1—4D  
 Dolorosa, Via . . . . . 16—4B  
 Dominicans' Convent . . . . . 16—3A  
 Dophkah? . . . . . 2—3J  
 Dor . . . . . 3, 4, 10, 11—2E; 2—6B  
 Dorylaion . . . . . 12—7B  
 Dothan . . . . . 3, 4, 10, 11—3F; 2—6B  
 Double Gate . . . . . 15—5D  
 Duer, ed. . . . . 14—6G  
 Duerban . . . . . 14—6F  
 Duket kafr-akib . . . . . 14—7C  
 Dyrrachium . . . . . 12—3A

## E

Ebal, Mount . . . . . 2—6C; 4—3G; 11—4G  
 Eber . . . . . 1—5D  
 Ecbatana . . . . . 5—5B; 6—4C  
 Ecdippa, see Achzib . . . . . 11—3C  
 Edom . . . . . 3—4L; 9—4J; 10—2L  
 Edom, Land of . . . . . 2—7G  
 Edrei . . . . . 3, 4—6E  
 Eglon . . . . . 4, 11—2J; 3—2I  
 Egnatia, Via . . . . . 12—4B  
 Egypt . . . . . 2—1G; 5—3C; 6—2D; 7—2C; 12—8H  
 Egypt, River of, see Wady  
 el 'Arish . . . . . 2—4E  
 Eidun (Dium or Dieu) . . . . . 3—5E  
 Ekron . . . . . 3, 4, 10, 11—2H; 9—3H

Ekseir, Wady el . . . . . 14—6J  
 Elam . . . . . 1—6E  
 Elath . . . . . 2—6H; 9—3L  
 Elealeh . . . . . 3—5H  
 Eleasa . . . . . 13—1C  
 Elen-beth-haman . . . . . 10—3H  
 Eleutheropolis . . . . . 11—2J  
 Elim . . . . . 2—3I  
 Elishah . . . . . 1—3D  
 Elon . . . . . 4—3H  
 Emesa . . . . . 9—5D  
 Emmaus . . . . . 11—4E  
 Emmaus (Amwas) . . . . . 11—2H  
 Emmaus? (Kulanieh) . . . . . 13—2E  
 Encampment by the Red  
 Sea . . . . . 2—3I  
 Endor . . . . . 4, 11—4E; 9—3G; 14—2H  
 Engannim . . . . . 4—2J and 3F  
 Engedi . . . . . 4, 11—4K; 9—3I; 10—4J  
 English Cemetery . . . . . 16—3E  
 En-hazar . . . . . 4—4C  
 En-rimmon . . . . . 4, 10—2K  
 En-tappuah . . . . . 4—3G  
 Entrance of Hamath? . . . . . 9—4D  
 Ephesus . . . . . 12—6D  
 Ephraim . . . . . 4, 11—3G  
 Ephraim, Mount . . . . . 3, 4, 10, 11—3G  
 Erech . . . . . 1—6E  
 Eriha, see Jericho . . . . . 13—7D  
 Erythraean Sea . . . . . 6—6D  
 Esh-sheh, Wady . . . . . 14—5K  
 Eshtaol . . . . . 4—3H; 11—2H  
 Estemoa . . . . . 4—3K  
 Etam . . . . . 4—2K; 11—3J  
 Etam (Urtas) . . . . . 13—3H  
 Etham, Wilderness of . . . . . 2—2G  
 Ethiopia . . . . . 6, 7—2E  
 Et-Tih, Desert of (Paran) . . . . . 2—4H  
 Eughib . . . . . 14—7E  
 Euphrates River (Great  
 River) . . . . . 5, 6—4C; 9—6B  
 Ezion-geber . . . . . 9—3L

## F

Fair Havens . . . . . 12—5E  
 Farah, Wady . . . . . 13—5D  
 Faria, Wady el . . . . . 3—3G; 11—4G  
 Feiyat, Wady es. . . . . 14—7B  
 Fejjas, Wady . . . . . 14—5G  
 Ferry . . . . . 14—6G  
 Feshkhah, Ras . . . . . 13—7G  
 Fikrah, Wady el . . . . . 3—3L  
 First Wall . . . . . 15—3D  
 Fish Gate . . . . . 15—3C  
 Frank Mountain, see Hero-  
 dium (Jebel Fureidis) . . . . . 13—3H  
 Freka . . . . . 14—6K  
 French Pilgrims' Ho. . . . . 16—2B  
 Fuleh, el . . . . . 14—1J

G

Gaash River . . . . . 11—3G  
 Gad . . . . . 4—4G  
 Gadara . . . . . 11—4E  
 Gadara (Mukes) . . . . . 14—7H  
 Gadosia . . . . . 6, 7—6D  
 Galatia . . . . . 8—5C; 12—9B  
 Galilee . . . . . 11—4D  
 Galilee, Sea of . . . . . 11—4D; 14—6D  
 Gallia . . . . . 8—2B  
 Gallim (Beit Jala) . . . . . 13—3G  
 Gamala . . . . . 11—4E  
 Gamala? (Kulat el Hosn) . . . . . 14—7E  
 Garden Tomb . . . . . 15—4A; 16—4A  
 Gath . . . . . 3—2I; 9—3H; 11—2H  
 Gath-hepher . . . . . 3—3E  
 Gath Hopher? (el Meshed) . . . . . 14—1F  
 Gath-libnah . . . . . 4—2J; 10—2H  
 Gaulonitis . . . . . 11—5D  
 Gaza . . . . . 3, 4, 10, 11—1J; 2—5D; 9—2I  
 Geba . . . . . 10, 11—3H; 10—3F  
 Geba, Gaba, Gibeah (Jeba) . . . . . 13—4D  
 Gebal (Byblos) . . . . . 9—4C; 12—10E  
 Gederah (Jedireh) . . . . . 13—3D  
 Gederoth . . . . . 4—2H  
 Gedor . . . . . 3—3I; 4—3J  
 Gedor (Kh. Jedur) . . . . . 13—1J  
 Gennath Gate . . . . . 15—3D  
 Gennesaret, Lake . . . . . 14—6D  
 Gennesaret, Plain of (el Ghuweir) . . . . . 14—5C  
 Gerar . . . . . 2—5D; 4—1K; 9—2I; 10—1J  
 Gerasa . . . . . 11—5F  
 Gergesa . . . . . 11—5D  
 Gergesenes? (Kersa) . . . . . 14—7D  
 Gerizim, Mount . . . . . 4, 11—3G; 2—6C  
 German Church . . . . . 16—3C  
 Germania . . . . . 8—3B  
 Geshur . . . . . 9—4F  
 Geshurites . . . . . 3—5D; 4—5C  
 Gether . . . . . 1—5D  
 Gethsemane . . . . . 16—6B  
 Gezer . . . . . 4—2H; 9—3H  
 Ghar, Wady el . . . . . 13—4L  
 Ghuweir, el; see Plain of Gennesaret . . . . . 14—5C  
 Ghuweir, Wady . . . . . 13—6J  
 Gibbethon . . . . . 4—3H; 10—3F  
 Gibeah . . . . . 4, 11—3H and 3J  
 Gibeah (Jeba) . . . . . 13—1H  
 Gibeah (Jebia) . . . . . 13—1D  
 Gibeon . . . . . 3, 4, 9, 10, 11—3H  
 Gibeon (el Jib) . . . . . 13—3D  
 Gihon . . . . . 15—5E  
 Gilboa . . . . . 11—4E  
 Gilboa, Mount . . . . . 10, 11—4F; 2—6B; 4—3F; 9—3G  
 Gilead . . . . . 4, 10—5F; 3—5G; 9—4G

Gilead, Mount . . . . . 2—7C; 4—4G; 3, 11—5G  
 Gilgal . . . . . 3, 4, 10, 11—4H; 3, 10—3G; 2—7C; 9—3H; 10—2G  
 Giloh (Kh. Jala) . . . . . 13—1J  
 Gischala . . . . . 11—4C  
 Gimzo . . . . . 4—2H; 10—2G  
 Golan . . . . . 3, 4, 10, 11—5D  
 Golden Gate . . . . . 15—5C  
 Gomer . . . . . 1—5C  
 Gophna Ophni (Jufna) . . . . . 13—3B  
 Gordium . . . . . 7—3B  
 Goshen, Land of . . . . . 2—1F  
 Great River, see Euphrates River . . . . . 9—6A  
 Great Sea (Mediterranean) . . . . . 4, 10—2D; 9, 11—2E; 1—4D; 2—4C; 3—1E  
 Grecia . . . . . 6, 7—2B  
 Grecian Empire . . . . . 7  
 Greece . . . . . 12—4D  
 Greek Gethsemane . . . . . 16—6C  
 Greek and Latin Quarter . . . . . 16—3C

H

Hadad-rimmon . . . . . 4—3E  
 Hadashah . . . . . 4—2J  
 Hadoram . . . . . 1—6F  
 Haemus Mountains . . . . . 12—4A  
 Hagar's Well, see Ain el-Muweileh . . . . . 2—4F  
 Hai, Kh. el . . . . . 13—4D  
 Haiyan, Kh., see Ai, Hai, Aiath . . . . . 13—4C  
 Halhul . . . . . 4—3J  
 Halhul (Hulhal) . . . . . 13—1K  
 Halys, River . . . . . 5, 6—3B; 12—9B  
 Hamam, Wady el . . . . . 14—5D  
 Hamath . . . . . 9—5C and 5D  
 Hamis, Wady . . . . . 13—3B  
 Hammath . . . . . 14—5E  
 Hammeh, el, see Zaphon-Amatha . . . . . 14—7G  
 Hammi, el . . . . . 14—6D  
 Hammon . . . . . 4—3C  
 Harod, Well of (Ain Jalud) . . . . . 14—2K  
 Harosheth . . . . . 3, 4—3E; 11—4C  
 Hasbeiyah . . . . . 11—4B  
 Hattin . . . . . 14—4D  
 Hauran . . . . . 4—6E  
 Hausan . . . . . 13—2G  
 Havilah . . . . . 1—5F and 6E  
 Havoth Jair . . . . . 4—6D  
 Hazar-enan . . . . . 9—5E  
 Hazeroth . . . . . 2—5I  
 Hazim, Wady el . . . . . 13—7E  
 Hazor . . . . . 3, 4, 10, 11—4C; 10—3G; 11—1J and 3H  
 Hazor (Kh. Hazzur) . . . . . 13—3E  
 Hazzur, Kh., see Hazor . . . . . 13—3E  
 Hebron . . . . . 3, 10, 11—3J; 9—3I

Hebron, see Kiriath-arba . . . 2-6D; 4-3J; 13-2L  
 Helam? . . . . . 9-6B  
 Helbon . . . . . 9-4E; 10-6A  
 Heliopolis . . . . . 9-4E  
 Helkath . . . . . 4-3D  
 Hellespont . . . . . 6-2B  
 Heraclea . . . . . 12-8A  
 Hermon, Mount . . . . . 4, 10, 11-5B; 9-4F  
 Herodium . . . . . 11-3J  
 Herodium (Jebel Fureidis or Frank Mountain) . . . . . 13-3H  
 Herod's Gate . . . . . 16-4A  
 Herod's Monument . . . . . 15-2E  
 Herod's Palace . . . . . 15-3D  
 Herod's Tombs . . . . . 16-2E  
 Heshbon . . . . . 3, 4, 10 11-5H; 2-7C; 9-4H  
 Hezekiah, Pool of . . . . . 16-3C  
 Hezron . . . . . 4-2M  
 Hibernia . . . . . 8-1A  
 Hierapolis . . . . . 12-7C  
 Hill Country . . . . . 11-3K  
 Hindi, Wady abu . . . . . 13-4F  
 Hinnom . . . . . 13-3F  
 Hinnom, Valley of . . . . . 15-2E and 2F  
 Hippius . . . . . 15-3D  
 Hippos (Susiyeh) . . . . . 14-7E  
 Hispania (Spain) . . . . . 8-1C  
 Hivites . . . . . 2-6B; 9-4F  
 Hizmeb, see Aznaveth . . . . . 13-4D  
 Holy Sepulchre, Church of the . . . . . 16-3C  
 Homonoea? (Umm Junieh) . . . . . 14-5G  
 Hor?, Mount . . . . . 9-4E  
 Hor?, Mount, see Jebel Nebi Harun . . . . . 2-6F  
 Hor, Mount, see Jebel Maderah . . . . . 2-6F  
 Horeb . . . . . 2-4J  
 Hormah . . . . . 3-1L; 9-3I  
 Hormah? (Zephath) . . . . . 4-3M  
 Hot Spring . . . . . 14-6N  
 Hukkuk . . . . . 4-4D  
 Hukkuk (Yakuk) . . . . . 14-4B  
 Hul . . . . . 1-6D  
 Hulhal, see Halhul . . . . . 13-1K  
 Husasah, Wady . . . . . 13-5L and 4K

## I

Ibleam . . . . . 4-4E; 11-3E  
 Ibleam or Bileam . . . . . 3-3F  
 Ibleam (Yebla) . . . . . 14-4J  
 ibn, Kh. . . . . 3-1B  
 Ibn es Seba . . . . . 3-1B  
 Ieonium . . . . . 12-8C  
 Ijon . . . . . 4, 10-4B; 9-4F  
 Iksal, see Chesulloth . . . . . 14-1G  
 Illyricum . . . . . 8-3C; 12-3A  
 India . . . . . 6, 7-7C  
 Indus River . . . . . 6, 7-6C  
 Ipsus . . . . . 7-2B

Irbid, see Arbela . . . . . 14-4D  
 Iron . . . . . 4-4C  
 Irpeel? (Ra-fal) . . . . . 13-3D  
 Israel . . . . . 10-4E  
 Israel, Mountains of . . . . . 11-4F  
 Israelites, Journey of . . . . . 3-5K  
 Issachar . . . . . 4-4E  
 Issus . . . . . 7-3B; 12-10D  
 Italia . . . . . 8-3C  
 Italy . . . . . 12-2B  
 Iturea . . . . . 11-6C

## J

Jabbok, see Wady Zerka . . . . . 11-5G  
 Jabbok River . . . . . 2-7C; 3-4G; 4-5G  
 Jabbul . . . . . 14-5K  
 Jabes, Wady . . . . . 11-5F  
 Jabesh-gilead . . . . . 4, 10-5F; 3-4F; 9-4G  
 Jabneel . . . . . 4-2H and 4E; 11-4C  
 Jabneel? (Yemma) . . . . . 14-4G  
 Jabneh . . . . . 10-2H  
 Jacob's Well . . . . . 11-3G  
 Jaffa Gate . . . . . 16-3C  
 Jahaz? . . . . . 4-5H and 5K; 3-5J  
 Jala, Kh., see Giloh . . . . . 13-1J  
 Jamnia . . . . . 11-2H  
 Janoah . . . . . 10-4B  
 Janohah . . . . . 4-4G  
 Janum . . . . . 4-3J  
 Janum (Beni Naim) . . . . . 13-2L  
 Japhia . . . . . 4-3E  
 Jarkon, Wady . . . . . 11-2H  
 Jarmuk River . . . . . 11-5E  
 Jarmuth . . . . . 3-2I; 4-3F and 2J; 10-3H  
 Jattir . . . . . 4-3K  
 Javan . . . . . 1-4D  
 Jazer . . . . . 3, 4, 11-5H  
 Jeba, see Geba, Gaba, Gibeah . . . . . 13-4D  
 Jeba, see Gibeah . . . . . 13-1H  
 Jebel 'Araif el-Nakah . . . . . 2-4G  
 Jebel Baten el Hawa, see Mount of Offense . . . . . 16-6E  
 Jebel Duhy . . . . . 14-2H  
 Jebel el-Megrah . . . . . 2-5G  
 Jebel et Tor, see Mount Tabor . . . . . 14-3G  
 Jebel et Tur, see Mount of Olives . . . . . 15, 16-7C  
 Jebel Fureidis, see Herodium (Frank Mountain) . . . . . 13-3H  
 Jebel Kuruntul . . . . . 13-6D  
 Jebel Maderah (Mount Hor) . . . . . 2-6F  
 Jebel Nebi Harun (Mount Hor?) . . . . . 2-6F  
 Jebel Shiha . . . . . 11-5K

- Jebel Toran . . . . . 14—2D  
 Jibia, see Gibeah . . . . . 13—1D  
 Jebus . . . . . 3—3I  
 Jebus, see Jerusalem . . . . . 4—3H  
 Jebusites . . . . . 2—6C  
 Jedireh, see Gederah . . . . . 13—3D  
 Jedur, Kh., see Gedor . . . . . 13—1J  
 Jefat, Kh., see Jiphthah?  
   Jotapata . . . . . 14—1D  
 Jehoshaphat, Valley of . . . . . 13—4F  
 Jehud . . . . . 4—2G  
 Jenah . . . . . 1—7F  
 Jeradat, Wady el . . . . . 13—3L  
 Jerafeh, Wady el . . . . . 2—6F  
 Jerash . . . . . 3—5F  
 Jeremiah's Grotto . . . . . 16—4A  
 Jerfan, Wady . . . . . 13—5H  
 Jericho . . . . . 3, 4, 10, 11—4H; 2—  
   6C; 9—3H  
 Jericho (Eriha) . . . . . 13—7D  
 Jeruel, Wilderness of . . . . . 10—3J; 13—4K  
 Jerusalem . . . . . 9, 10, 11—3H; 5,  
   6—3C; 12—10G  
 Jerusalem (El Kuds) . . . . . 13—3F  
 Jerusalem (Jebus) . . . . . 4—3H  
 Jerusalem, see Salem . . . . . 2—6D  
 Jeshanah . . . . . 10—3G  
 Jeshimon . . . . . 4—3K  
 Jessarah, Wady . . . . . 13—7K  
 Jethlah (Beit Tul) . . . . . 13—1E  
 Jewish Cemetery . . . . . 16—4F and 6D  
 Jewish Colony . . . . . 16—2E and 3A  
 Jewish Quarter . . . . . 16—4D  
 Jews' Wailing Place . . . . . 16—4D  
 Jezreel . . . . . 4, 11—3E; 4—3K;  
   9—3G; 10—4E  
 Jezreel (Zerin) . . . . . 14—1K  
 Jezreel, Valley of (Nahr  
   Jalud) . . . . . 14—3K  
 Jib, el, see Gibeon . . . . . 13—3D  
 Jihar, Wady el . . . . . 13—3K  
 Jiphthah?, Jotapata (Kh.  
   Jefat) . . . . . 14—1D  
 Jisr el Mujamiyeh . . . . . 14—5H  
 Jobab . . . . . 1—7F  
 Jogbehah . . . . . 4—5G  
 Jokneam . . . . . 3, 4, 10—3E  
 Joktan . . . . . 1—6F  
 Joktheel . . . . . 4, 10—2H  
 Joppa . . . . . 3, 4, 10, 11—2G; 2—  
   5C; 9—3H; 12—  
   10G  
 Jordan River . . . . . 3, 4, 10, 11—4F; 2—  
   7B; 3—4C; 4—5B;  
   9—3H; 12—10G;  
   14—6A and 6K  
 Jotopata . . . . . 11—3D  
 Jubb Yusef, Kh. . . . . 14—5B  
 Judaea . . . . . 5, 7—3C; 6—2C; 8—  
   5D; 11—3J; 12—  
   10G  
 Judaea, Wilderness of . . . . . 4—4K  
 Judah . . . . . 4—3J; 10—2J  
 Judah, Mountains of . . . . . 3—3J  
 Judah, Wilderness of . . . . . 9—3I  
 Jufna, see Gophna Ophni . . . . . 13—3B  
 Juttah . . . . . 4, 11—3K
- K
- Kabu, el . . . . . 13—2G  
 Kadesh, see Ain Kadeis . . . . . 2—4F  
 Kadesh?, see Ain el Weibeh . . . . . 2—6F  
 Kadish, see Kedesh . . . . . 14—5F  
 Kady, Wady el . . . . . 13—2L  
 Kala 'at el-'Akabah . . . . . 2—6H  
 Kala 'at el 'Arish . . . . . 2—4E  
 Kala 'at en Nakhl . . . . . 2—4H  
 Kana, Kh., see Cana . . . . . 14—1D  
 Kanah . . . . . 4, 11—3C  
 Kanah, Brook . . . . . 4—2G  
 Karnaim . . . . . 11—5E  
 Kaukab el Hawa . . . . . 14—5J  
 Kedesh . . . . . 10, 11—4C; 9—3F  
 Kedesh (Kadish) . . . . . 14—5F  
 Kedesh-naphthali . . . . . 3, 4—4C  
 Kedron, Brook . . . . . 10—4H; 11—3J  
 Kefireh, see Chephirah . . . . . 13—1E  
 Kefr Ana, see Chephar-ham-  
   mon-ai? . . . . . 13—4B  
 Kefr Anan . . . . . 14—3B  
 Kefr et Tor, see Bethphage? . . . . . 13—4F  
 Kefr Harib . . . . . 14—7E  
 Kefr Kama . . . . . 14—3F  
 Kefr Kenna, see Cana of  
   Galilee . . . . . 14—2F  
 Kefr Malik . . . . . 13—5A  
 Kefr Misr . . . . . 14—3H  
 Kefr Sabt . . . . . 14—3F  
 Keilah . . . . . 4—2J; 11—3J  
 Kenath . . . . . 9—5G; 10—7D  
 Keniset er-Rawat . . . . . 13—3G  
 Kerak Kir-moab . . . . . 11—5L  
 Kerak, see Tarichaea . . . . . 14—6F  
 Kerazeh, see Chorazin . . . . . 14—5B  
 Kerek, Brook . . . . . 11—5L  
 Kerioth . . . . . 4—3K; 10—7E  
 Kersa, see Gergesenes? . . . . . 14—7D  
 Kiblem, Wady el . . . . . 3—1A  
 Kidron, Brook . . . . . 3—4I  
 Kidron or Cedron, Brook  
   (Wady en Nar) . . . . . 13—5G  
 Kidron, Valley of the . . . . . 16—5D  
 Kir . . . . . 2—7E  
 Kiriathaim . . . . . 3—5I; 4—4J  
 Kiriath-arba (Hebron) . . . . . 2—6D; 4—3J  
 Kiriath-jeirim . . . . . 3—3I; 4—3H  
 Kiriath-sephar . . . . . 4—2K  
 Kirjath? (Kuryet et Enab) . . . . . 13—2E  
 Kir-moab . . . . . 3—4K; 4—4L; 9—  
   4I; 10—5K  
 Kishon, Brook . . . . . 3—3E; 4—3D; 11—  
   3E  
 Kithlish . . . . . 4—2J  
 Kitron . . . . . 3, 4—3D

Kittim . . . . . 1—5D; 9—1C  
 Khamaseh, Kh. el. . . . . 13—1G  
 Khan et Tujjar . . . . . 14—3F  
 Khneizir . . . . . 14—7H  
 Khudr, el. . . . . 13—2G  
 Khulil, el, see Hebron, Kir-  
 iath-arba . . . . . 13—2L  
 Khurbetha . . . . . 3—1B  
 Khurbet-hellabi . . . . . 3—2A  
 Khureitun, Kh. el. . . . . 13—4J  
 Kolt, Wady . . . . . 11—4H  
 Kubar . . . . . 13—2A  
 Kubeibeh, el. . . . . 13—2D  
 Kuds, el, see Jerusalem . . . . . 13—3F  
 Kueziba, Kh., see Chozeba . . . . . 13—2K  
 Kulanieh, see Emmaus? . . . . . 13—2E  
 Kulat el Hosn, see Gamala? . . . . . 14—7E  
 Kumran, Kh. . . . . 13—7F  
 Kumran, Wady . . . . . 13—7F  
 Kurm Atrad, Kh. . . . . 13—6F  
 Kurn Hattin . . . . . 14—4E  
 Kuryet et Enab, see Kir-  
 jath? . . . . . 13—2E  
 Kustul . . . . . 13—2E

## L

Lachish . . . . . 3, 4, 10, 11—2J; 9—3I  
 Lahman . . . . . 4—2J  
 Laish, see Dan . . . . . 3—4B; 4—5B  
 Laodicea . . . . . 12—7C  
 Lasea . . . . . 12—5E  
 Lasharon, see Sharon . . . . . 11—2G  
 Lebanon, Mount . . . . . 4, 10, 11—4A; 9—4E  
 Lebonah . . . . . 10, 11—3G  
 Lehabim . . . . . 1—4D  
 Leontes River . . . . . 4, 10, 11—4B; 9—4E  
 Libnah . . . . . 3, 11—2I; 9—3I  
 Libya . . . . . 8—4E; 12—5H  
 Libyan Desert . . . . . 1—4E  
 Lifta . . . . . 13—3E  
 Little Hermon . . . . . 11—3E  
 Lod . . . . . 10—2G  
 Lower Beth-horon . . . . . 4, 10—3H; 13—1C  
 Loz, Kh. el. . . . . 13—1F  
 Lubieh . . . . . 14—3E  
 Lubim . . . . . 1—4E  
 Lud . . . . . 1—3D and 5D  
 Ludim . . . . . 1—3D  
 Luz . . . . . 4—4B  
 Lycia . . . . . 12—7D  
 Lydda . . . . . 4, 11—2H  
 Lydia . . . . . 6, 7—2B  
 Lystra . . . . . 12—8D

## M

Maachah . . . . . 9—6F  
 Maachathites . . . . . 4—5C  
 Maad . . . . . 14—6J  
 Maarath . . . . . 4—3J  
 Macedonia . . . . . 7—2B; 8—4C; 12—  
 4B  
 Machaerus . . . . . 11—5J

Madai . . . . . 1—7D  
 Madher . . . . . 14—4G  
 Madin, see Madon? . . . . . 14—4D  
 Madon? (Madin) . . . . . 14—4D  
 Magdala . . . . . 11—4D  
 Magdala (Mejdel) . . . . . 14—4D  
 Magog . . . . . 1—7C  
 Mahanaim . . . . . 3, 4, 10—5F; 2—7B;  
 9—4G  
 Mahometan Quarter . . . . . 16—4B  
 Makht Abarah, see Beth-  
 barah, Bethabara? . . . . . 14—5K  
 Makkedah . . . . . 3—2I; 4—2H; 11—2J  
 Maktul, Wady . . . . . 14—4B  
 Malhah, see Manahath . . . . . 13—3F  
 Malick, Wady el. . . . . 13—6C  
 Malih, Wady el. . . . . 11—4F  
 Malta, see Melita . . . . . 12—1D  
 Mamre, Plain of . . . . . 13—1L  
 Manahath (Malhah) . . . . . 13—3F  
 Manasseh . . . . . 4—3F and 6D  
 Mansurah, el. . . . . 14—3B  
 Maon . . . . . 4, 10, 11—3K  
 Marah (Wells of Moses) . . . . . 2—2G  
 Mare Atlanticum . . . . . 8—1B  
 Mare Caspium . . . . . 8—6B; 7—4B  
 Mare Internum . . . . . 8—4D  
 Mar Elias . . . . . 13—3G  
 Maresah . . . . . 10, 11—2J  
 Mariamne Tower . . . . . 15—3C  
 Marrina, Kh., see Meronoth 13—1J  
 Mar Saba . . . . . 13—5G  
 Masada . . . . . 11—4K  
 Mash . . . . . 1—6D  
 Maspha, Mizpah (Neby  
 Samwil) . . . . . 13—2D  
 Mauritania . . . . . 8—1D  
 Mazar, el. . . . . 14—2M  
 Medeba . . . . . 4, 11—5J; 3—5I; 9—  
 4H; 10—5H  
 Media . . . . . 6, 7—4C; 5—5B  
 Medineh, Wady . . . . . 13—4D  
 Mediterranean Sea, see Great  
 Sea . . . . . 4, 10—2D; 2—4C;  
 3—1E; 11—2E; 12—  
 4F  
 Megiddo . . . . . 3, 4, 10, 11—3E; 9—  
 3G  
 Mejdel, see Magdala . . . . . 14—4D  
 Melita (Malta) . . . . . 12—1D  
 Memphis . . . . . 1—5E; 5—3C; 6—2C  
 Menaah, Kh. . . . . 3—1B  
 Mendah . . . . . 14—7K  
 Menka, Wady el. . . . . 13—4J  
 Merom, Waters of . . . . . 4, 10—5C; 2—7A; 3—  
 4C  
 Meronoth (Kh. Marrina) . . . . . 13—1J  
 Merv . . . . . 7—6B  
 Mesadiyah, el . . . . . 14—6C  
 Meshah . . . . . 1—6E  
 Meshash, Wady . . . . . 13—5J  
 Meshech . . . . . 1—6C



Meshed, el, see Gath Heph-  
er? . . . . . 14—1F  
Mesopotamia . . . . . 5—4B; 8—6D  
Messina . . . . . 12—2C  
Mezeirat el Kibliyeh . . . . . 13—2B  
Michmash . . . . . 4—3H  
Michmash (Mukhmas) . . . . . 13—4C  
Middin . . . . . 4—3J  
Midian . . . . . 2—6I  
Midianites . . . . . 3—6J; 9—6G  
Migdal-gad . . . . . 4—1J  
Migdol . . . . . 2—1F  
Migdol, el . . . . . 4—4C  
Mikyal, Kh. el . . . . . 14—7H  
Miletus . . . . . 12—6D  
Minieh, Kh., see Caper-  
naum . . . . . 14—5C  
Miristan . . . . . 16—3C  
Mishal . . . . . 4—3D  
Mitylene . . . . . 12—6C  
Mizpah . . . . . 4—3H  
Mizpeh . . . . . 4—5F; 10—3H; 11—  
6E  
Mizraim . . . . . 1—5E; 2—1G  
Moab . . . . . 3, 4, 10, 11—5K; 2—  
7E; 9—4I  
Moeris . . . . . 6—3A  
Moesia . . . . . 8—4C; 12—5A  
Mojib, Wady el, or River  
Arnon . . . . . 11—5K  
Moladah . . . . . 4, 10, 11—3L; 9—3I  
Moriah . . . . . 16—5C  
Mosque . . . . . 16—5C  
Mount Zion Street . . . . . 16—3D  
Mozah (Kh. Beit Mizza) . . . . . 13—2E  
Muallak, Wady el . . . . . 13—5K  
Mughar, el . . . . . 14—3B  
Mujedda, el . . . . . 14—4N  
Mukelik, Wady . . . . . 13—6F  
Mukes, see Gadara . . . . . 14—7H  
Mukhmas, see Michmash . . . . . 13—4C  
Mukhraba . . . . . 14—7K  
Mukta el Juss, Wady . . . . . 13—5K  
Muntar, el . . . . . 13—5G  
Murussus, Kh. el . . . . . 13—5F; 14—4K  
Musheirfi, el . . . . . 14—7J  
Musurr, Wady . . . . . 13—2H  
Myra . . . . . 12—8D  
Mysia . . . . . 6, 7—2B; 12—6B

## N

Naarath . . . . . 4—4H  
Nahalal . . . . . 3—3E  
Nahallal? . . . . . 4—3E  
Nahallal? (Ain Mahil) . . . . . 14—2F  
Nahr Jalud, see Valley of  
Jezreel . . . . . 14—3K  
Nain . . . . . 11—4E  
Nain (Nein) . . . . . 14—2H  
Naphtali . . . . . 4—4C  
Naphtuhim . . . . . 1—4E  
Naples . . . . . 12—1B

Nar, Wady en, see Brook  
Kidron or Cedron . . . . . 13—5G  
Nasirah, en, see Nazareth . . . . . 14—1G  
Naurah, en, see Anaharath? . . . . . 14—3J  
Nazareth . . . . . 11—3E; 12—10F  
Nazareth (en Nasirah) . . . . . 14—1G  
Neapolis . . . . . 12—5B  
Nebo, Mount . . . . . 3, 4, 10, 11—5H; 2—  
7D; 9—4H  
Neby Musa . . . . . 13—7E  
Neby Sain . . . . . 14—1F  
Neby Samwil, see Maspha,  
Mizpah . . . . . 13—2D  
Negeb, The . . . . . 4—2L  
Neiel . . . . . 4—3D  
Nein, see Nain . . . . . 14—2H  
Nekeb . . . . . 4—4E  
New Bazaar . . . . . 16—2C  
New Greek Convent . . . . . 16—3B  
Nezib . . . . . 4—2J; 11—3J  
Nicomedia . . . . . 12—7B  
Nicompolis . . . . . 12—4C  
Nile, Mouth of the . . . . . 2—1D  
Nile River . . . . . 5—3D  
Nimrin . . . . . 14—3D  
Nineveh . . . . . 1—6D; 5—4B  
Nobah, see Kenath . . . . . 9—4G  
Noricum . . . . . 8—3B  
Northern Campaign . . . . . 3—4F  
Numidia . . . . . 8—2D

## O

Obal . . . . . 1—6F  
Offense, Mount of (Jebel  
Baten el Hawa) . . . . . 16—6E  
Old Pool . . . . . 16—4F  
Olives, Mount of . . . . . 13—4F; 11—3H  
Olives, Mount of (Jebel et  
Tur) . . . . . 15, 16—7C  
Omar's Mosque . . . . . 16—3C  
Ono . . . . . 4, 10—2G  
Ophel . . . . . 16—4D  
Ophir? . . . . . 1—6F; 5—4E  
Ophrah . . . . . 4, 10—3G  
Ophrah Ephraim (el Tai-  
yibeh) . . . . . 13—5B  
Orontes River . . . . . 9—4C  
Osh el Ghurab (Rock Oreb?) . . . . . 13—7C  
Oxus River . . . . . 6—6B; 7—5B

## P

Palmyra, see Tadmor . . . . . 9—6D  
Pamphylia . . . . . 12—8D  
Pamphylia, Sea of . . . . . 12—8D  
Pannonia . . . . . 8—4B  
Paphlagonia . . . . . 6—2B; 7—3B; 12—9A  
Paphos . . . . . 12—9E  
Parah . . . . . 13—5D  
Paran, see Desert of Et-Tih . . . . . 2—4H  
Paran, Wilderness of . . . . . 9—1L  
Parthia . . . . . 6, 7—5C; 8—6C  
Patara . . . . . 12—7D

Pathrusim . . . . . 1—5E  
 Patmos . . . . . 12—6D  
 Pella . . . . . 11—4F  
 Pelusium . . . . . 2—2E  
 Pelusium, Bay of . . . . . 2—2E  
 Penuel? . . . . . 4, 10, 11—4G  
 Peraea . . . . . 11—5H  
 Perga . . . . . 12—8D  
 Pergamos . . . . . 12—6C  
 Perizzites . . . . . 2—6C  
 Persepolis . . . . . 6, 7—5C  
 Persia . . . . . 6, 7—5C  
 Persian Empire . . . . . 6  
 Persian Gulf . . . . . 1—7E; 6—4D  
 Pessinus . . . . . 12—8C  
 Petra . . . . . 2—7F  
 Pharpar River . . . . . 4, 10, 11—6B; 9—4F  
 Phasaelus . . . . . 15—2C  
 Phasis River . . . . . 6—4B  
 Phenice . . . . . 7—3C  
 Phiala, Lake . . . . . 11—5C  
 Philadelphia . . . . . 12—7C  
 Philippi . . . . . 12—5B  
 Philistia . . . . . 4—1J  
 Philistim . . . . . 1—5E  
 Philistines . . . . . 2—5D; 3—2H; 9—2I  
 Phoenicia . . . . . 9—4E; 11—3C; 12—  
     10F  
 Phoenix . . . . . 12—5E  
 Phrygia . . . . . 6, 7—2B; 12—7C  
 Phut . . . . . 1—4E  
 Pi-hahiroth . . . . . 2—1G  
 Pilgrim Road to Mecca or  
     Derb el Hajj . . . . . 2—4H; 11—6K  
 Pillars of Hercules . . . . . 8—1C  
 Pirathon . . . . . 4—3F  
 Pisgah, Mount . . . . . 4—4J  
 Pisidia . . . . . 12—8D  
 Pithom . . . . . 2—1F  
 Plain, Sea of the . . . . . 3—4I  
 Pontus . . . . . 6, 7—3B; 8—5C; 12—  
     9A  
 Pontus Euxinus . . . . . 6, 7—3A; 8—5C  
 Pontus Galaticus . . . . . 12—9B  
 Protestant School . . . . . 16—3E  
 Propontis . . . . . 12—7B  
 Pteria . . . . . 5—3B  
 Ptolemais . . . . . 12—10F  
 Ptolemais (Acco) . . . . . 11—3D  
 Puteoli . . . . . 12—1B

## R

Raamah . . . . . 1—7E  
 Raamses? . . . . . 2—1F  
 Rabbah . . . . . 3—5H; 4—2J  
 Rabbath-ammon . . . . . 4, 10, 11—5H; 9—4H  
 Rabbath-moab, see Ar . . . . . 11—5K  
 Rabbith . . . . . 4—3F  
 Rachael's Tomb . . . . . 13—3G  
 Ra-fal, see Irpeel? . . . . . 13—3D  
 Rakkath . . . . . 4—4D  
 Rakkon . . . . . 4—2G

Ramah . . . . . 4, 10, 11—3H and 4D  
 Ramah (er Ram) . . . . . 13—3D  
 Ramah (Rameh) . . . . . 14—2A  
 Ram Allah . . . . . 13—3C  
 Rameh, see Ramah . . . . . 14—2A  
 Ram, er, see Ramah . . . . . 13—3D  
 Ramleh . . . . . 11—2H  
 Ramoth-gilead . . . . . 3, 4, 10, 11—5G; 9—  
     4H  
 Ramoth-mizpeh . . . . . 4—5E  
 Raphia, see Tell Refah . . . . . 2—4E  
 Ras Mersid . . . . . 13—6M  
 Ras es Shukf . . . . . 13—6M  
 Red Sea . . . . . 2—5L; 7—3D; 9—3L;  
     12—9H  
 Regnum Antiochi . . . . . 12—9D  
 Regnum Polemonis . . . . . 12—10B  
 Rehob . . . . . 9—5E  
 Rehoboth . . . . . 1—5D; 4—1L  
 Reineh, er . . . . . 14—1F  
 Rephaim, Valley of . . . . . 13—3F  
 Rephidim . . . . . 2—4J  
 Resen . . . . . 1—6D  
 Reuben . . . . . 4—4J  
 Rezech . . . . . 9—7C  
 Rhaetia . . . . . 8—3B  
 Rhegium . . . . . 12—2C  
 Rhodes . . . . . 12—7E  
 Riblah . . . . . 9—5D; 11—5B  
 Rimmon . . . . . 4—3D and 3H; 10—  
     4D; 11—2K  
 Rimmon Dimnah (Rum-  
     maneh) . . . . . 14—1E  
 Riphath . . . . . 1—4C  
 Rock Oreb? (Osh el Ghurab) . . . . . 13—7C  
 Rock Rimmon (Rummon) . . . . . 13—5B  
 Roma (Kh. Rumah) . . . . . 14—1E  
 Roman Empire . . . . . 8  
 Roman Road . . . . . 11—5K  
 Rome . . . . . 8—3C; 12—1A  
 Ruad I. . . . . 9—4D  
 Rumah, Kh., see Roma . . . . . 14—1E  
 Rummaneh, see Rimmon  
     Dimnah . . . . . 14—1E  
 Rummaneh, Wady . . . . . 14—2E  
 Rummon, see Rock Rim-  
     mon . . . . . 13—5B  
 Russian Hospice . . . . . 16—1A  
 Russian Mission . . . . . 16—1B

## S

Sabeans . . . . . 5—3E and 4E  
 Sabtar . . . . . 1—6F  
 Sabteca . . . . . 1—6G  
 Safa . . . . . 13—1H  
 Sahel el Ahma, see Bet-  
     saanim . . . . . 14—4F  
 Sahel el Buttauf, see Plain  
     of Asochis . . . . . 14—2D  
 Sakhni, Kh. es . . . . . 14—6J  
 Salamis . . . . . 12—9E  
 Salcah . . . . . 9—5G

- Salem (Jerusalem).....2—6D  
 Salim.....11—4F  
 Salmona, Cape.....12—6E  
 Salt Sea (Dead Sea).....11—4K; 2—7D; 4—4J; 9—3I  
 Samaria.....6, 7—3C; 10, 11—3F; 8—5D; 9—3H; 12—10G  
 Samieh, Wady.....13—5A  
 Samos.....12—6D  
 Samrah.....14—6F  
 Saphir.....11—1J  
 Sardinia.....8—3C  
 Sardis.....12—7C  
 Sarepta.....11—3B  
 Saris.....13—1E  
 Sarmatia.....8—5A  
 Sarona.....14—4F  
 Schaib, Wady.....11—4H  
 Scythia.....1—8C; 6—4A; 8—6B  
 Scythopolis.....11—4E; 14—4M  
 Sea of Galilee, see Lake Tiberias.....11—4D  
 Sea of the Plain.....4—4K; 10—4J  
 Seba.....1—5F; 5—3E  
 Sechu? (Kh. Suweikeh).....13—3C  
 Second Wall.....15—3C  
 Seffurieh, see Sepphoris.....14—1E  
 Seir, Mount.....2—7F; 9—3J  
 Seiyadeh.....14—5F  
 Sela?.....9—3J  
 Seleucia.....7—3B and 4C; 12—9D and 10D  
 Seli, Wady.....11—4H  
 Selwad.....13—4A  
 Semakh.....14—6G  
 Semakh, Wady es.....14—7D  
 Sephar?, Mount.....1—7F  
 Sepphoris.....11—3E  
 Sepphoris (Seffurieh).....14—1E  
 Seveneh.....6—2D  
 Shaalabbin.....4, 10—3H  
 Shafal.....13—3E  
 Shalem.....11—4F  
 Shalim.....2—6C; 4—3G  
 Shariat el-Menadrieh, see River Yarmuk.....14—6G  
 Sharon (Lasharon).....11—2G  
 Sharon, Plain of.....3, 4, 10, 11—2F  
 Sheba.....1—6E and 6F; 5—4E and 5C  
 Shechem.....3, 4, 10, 11—3G; 2—6C; 9—3H  
 Shehab, Wady esh.....3—2B  
 Sheleph.....1—6F  
 Shemesh, En (Ain Haud).....13—4F  
 Shemsin, Kh.....14—5G  
 Shephelah.....4—2J  
 Sherafat.....13—3F  
 Sherrar, Wady esh.....14—3H  
 Shihon (Ain Sha'in?).....14—2F  
 Shiloh.....3, 4, 10, 11—4G; 9—3H  
 Shimron.....3, 4—3E  
 Shinar.....1—6D  
 Shittim.....11—4H  
 Shkeiyif.....14—7C  
 Shukf, Wady esh.....13—6M  
 Shunem.....4, 10, 11—4E; 9—3G  
 Shunem (Solam).....14—2J  
 Shushan (Susa).....5—5C; 6—4C  
 Shutta, see Beth-shittah.....14—3K  
 Siair, see Zior.....13—2K  
 Sicilia.....8—3C  
 Sicily.....12—1C  
 Sidon.....4, 10, 11—4A; 1—5D; 9—3F; 12—10F  
 Sidonians.....4—4B  
 Sidr, Wady es.....14—3J  
 Sikkeh, Wady es.....13—1F  
 Siklab, Wady.....14—6M  
 Siloam, Pool of.....15, 16—4F  
 Siloam, Village of.....16—5E  
 Simeon.....4—2L  
 Sin, Wilderness of.....2—3J  
 Sinai, Mount.....2—4J  
 Sinai, Wilderness of.....2—4J  
 Single Gate.....15—5D  
 Sinim?.....1—12D  
 Sinnabris (Sinn en Nabrah).....14—5F  
 Sinn en Nabrah, see Sinabris.....14—5F  
 Sinope.....6—3B; 12—9A  
 Sinus Persicus.....7—5D  
 Sirah Well.....13—1L  
 Sir Bahir.....13—3G  
 Sirbonis, Lake.....2—3E  
 Sirin.....14—5H  
 Smyrna.....12—6C  
 Soba.....13—2F  
 Socoh.....4—2J and 3K; 10—3J  
 Sogdiana.....6, 7—6B  
 Solam, see Shunem.....14—2J  
 Sorek, Brook.....11—1J  
 Southern Campaign.....3—2I  
 Spain, see Hispania.....8—1C  
 St. Paul's Bay.....12—1D  
 St. Stephen's Gate.....16—5B  
 Succoth?.....4, 10 11—4F; 2—1F and 7C; 9—4H  
 Suez.....2—2G  
 Suez, Gulf of.....2—2J  
 Suffa.....3—1A  
 Sukhnin.....14—1C  
 Sukiye, Wady es.....13—4M  
 Sumrah, Kh. es.....13—6G  
 Surar, Wady.....13—2F  
 Susa, see Shushan.....5—5C; 6—4C  
 Susiana.....6, 7—4C  
 Susiyeh, see Hippos.....14—7E  
 Suweikeh, see Sechu?.....13—3C  
 Suweinit, Wady.....13—5D

Sychar . . . . . 11—3F  
 Syracuse . . . . . 8—3D; 12—2D  
 Syria . . . . . 6, 7—3C; 5—3B; 8—  
 5D; 12—10E  
 Syria or Aram . . . . . 9—6D  
 Syrian Desert . . . . . 9—6F

## T

Taanach . . . . . 3, 4, 10—3E; 9—3G  
 Taanath . . . . . 4—4G  
 Taba . . . . . 2—6H  
 Tabghah, et . . . . . 14—5C  
 Tabor, Mount . . . . . 2—6B; 4—4E; 11—  
 3E  
 Tabor, Mount (Jebel et Tor) 14—3G  
 Tadmor (Palmyra) . . . . . 9—6D  
 Tahpanhes . . . . . 2—1E  
 Taiyibeh, et . . . . . 14—3J  
 Taiyibeh, et, see Ophrah  
 Ephraim . . . . . 13—5B  
 Tamireh, Wady . . . . . 13—4H  
 Tanitic . . . . . 2—2E  
 Tappuah . . . . . 11—4G  
 Tarentum . . . . . 12—3B  
 Tarentum Gulf . . . . . 12—3B  
 Tarichaea? (Kerak) . . . . . 14—6F  
 Tarsessus . . . . . 8—1C  
 Tarshish . . . . . 1—2C  
 Tarsus . . . . . 12—9D  
 Taurus Mountains . . . . . 12—9D  
 Tavium . . . . . 12—9B  
 Tekoa . . . . . 4—3J  
 Tekoa (Kh. Tekua) . . . . . 13—3J  
 Tekoa, Wilderness of . . . . . 10—3H; 13—5J  
 Tekoah . . . . . 11—3J  
 Tekua, Kh., see Tekoa . . . . . 13—3J  
 Teli Asur, see Baal-hazor . . . . . 13—4A  
 Tell el Ful . . . . . 13—3E  
 Tell el Wawiyat . . . . . 14—1D  
 Tell es Sultan . . . . . 13—7D  
 Tell, et . . . . . 13—4C  
 Tell Hamma . . . . . 14—6N  
 Tell Hum . . . . . 14—5C  
 Tell Refah (Raphia) . . . . . 2—4E  
 Tell Zaraa . . . . . 14—7J  
 Temple . . . . . 15—5C  
 Temple Area . . . . . 16—5C  
 Temple Street . . . . . 16—4C  
 Thapsacus, see Tiphseh . . . . . 9—7B  
 Thebae . . . . . 6—2D  
 Thebez . . . . . 4, 11—3F  
 Thessalonica . . . . . 12—5B  
 Third Wall . . . . . 15—2B  
 Thrace . . . . . 7—2B; 12—6A  
 Thracia . . . . . 8—4C  
 Three Taverns . . . . . 12—1A  
 Thyatira . . . . . 12—7C  
 Tiberias . . . . . 11—4D  
 Tiberias, Lake (Bahr Tu-  
 bariya) . . . . . 14—6E  
 Tiberias, Lake (Sea of Gali-  
 lee) . . . . . 11—4D

Tiberias Rakkath (Tuba-  
 riya) . . . . . 14—5E  
 Tigris River . . . . . 5, 6—4C; 8—6D  
 Timnath . . . . . 4, 10, 11—2H; 4—3G  
 Timnath-serah . . . . . 4—3G  
 Tiphseh (Thapsacus) . . . . . 9—7B  
 Tiphseh . . . . . 4—3G; 10—3F  
 Tiras . . . . . 1—5C  
 Tireh, et . . . . . 13—2D  
 Tirzah . . . . . 3, 4, 10, 11—3F; 9—  
 3G  
 Titus, Wall of Circumvalla-  
 tion . . . . . 15—2D  
 Tob, Land of . . . . . 4—4E  
 Togarmah . . . . . 1—5D  
 Tombs of the Prophets . . . . . 16—7D  
 Tophel . . . . . 4, 11—4M; 2—7E  
 Toran . . . . . 14—2E  
 Tower Psephinus . . . . . 15—1B  
 Triple Gate . . . . . 15—5D  
 Tripolis . . . . . 9—4D; 12—10E  
 Troas . . . . . 12—6C  
 Tubal . . . . . 1—5D  
 Tubania (Ain Tubaun) . . . . . 14—2K  
 Tubariya, see Tiberias Rak-  
 kath . . . . . 14—5E  
 Tubk Amriyeh . . . . . 13—6G  
 Tuffah, Wady et . . . . . 14—3C  
 Tyre . . . . . 3, 4, 7, 10, 11—3C;  
 9—3F; 12—10F; 8  
 —5D  
 Tyropoeon Valley . . . . . 15—3B

## U

Ulai River . . . . . 6—4C  
 Ummah . . . . . 4—3C  
 Umm Junieh, see Ho-  
 monoea? . . . . . 14—5G  
 Umm Taba, Kh . . . . . 13—3G  
 Upper Beth-horon . . . . . 3—2B; 4—3H; 13  
 —1C  
 Upper City . . . . . 15—3E  
 Upper Conduit . . . . . 16—2C  
 Upper Pool of Gihon . . . . . 16—1C  
 Urtas, see Etam . . . . . 13—3H  
 Uz . . . . . 1—5E  
 Uzal . . . . . 1—6F

## V

Valley of Kidron . . . . . 15—5D  
 Virgin's Fount . . . . . 16—5E

## W

Wakkas . . . . . 14—7F  
 War, Wady el . . . . . 13—4H  
 Warmuk River . . . . . 3—5E  
 Water Gate . . . . . 15—5E  
 Weleje, el . . . . . 13—2G  
 Women's Tower . . . . . 15—3A

## Y

Yakuk, see Hukkuk . . . . . 14—4B  
 Yarmuk River . . . . . 4—5E; 10—5D

Yarmuk River (Shariat el-Menadrieh) . . . . . 14—6G  
 Yebla, see Ibleam . . . . . 14—4J  
 Yebrud . . . . . 13—4A  
 Yemma, see Jabneel . . . . . 14—4G  
 Yukin, Kh . . . . . 13—2M

Z

Zanoah . . . . . 4—2J  
 Zaphon . . . . . 4—4E  
 Zaphon Amatha (el Ham-meh) . . . . . 14—7G  
 Zarephath . . . . . 4—3B; 10—3A  
 Zaretan . . . . . 11—4F  
 Zarthan? . . . . . 10—4G  
 Zebda . . . . . 14—7K  
 Zebulun . . . . . 4, 11—3D  
 Zephath, see Hormah? . . . . . 4—3M  
 Zephathah, Wady . . . . . 11—2J  
 Zer? . . . . . 14—5E

Zered, Brook . . . . . 2—7E; 3—4K; 4—4L; 11—5M  
 Zereda? . . . . . 13—3B  
 Zerin, see Jezreel . . . . . 14—1K  
 Zerka Maan, Wady . . . . . 11—5J  
 Zerka, Wady, or Jabbok . . . . . 11—5G  
 Ziddim . . . . . 4—4D  
 Ziklag? . . . . . 4—2L; 9—3I  
 Zin, Wilderness of . . . . . 9—3K  
 Zion? . . . . . 15—4E; 16—3D  
 Zion Gate . . . . . 16—3E  
 Zion, Mount . . . . . 15—3D  
 Zior (Siair) . . . . . 13—2K  
 Ziph . . . . . 4, 10, 11—3K  
 Zoan . . . . . 2—1E  
 Zoar? . . . . . 11—4L  
 Zobah? . . . . . 9—4E  
 Zoheleth . . . . . 15—5E  
 Zorah . . . . . 4—2H; 10—3H  
 Zuhluk, Wady . . . . . 14—6B



# THE ANCIENT WORLD AND THE DESCENDANTS OF NOAH Gen. 10.

Shem's Descendants. ---  
 Ham's Descendants. ---  
 Japheth's Descendants. ---

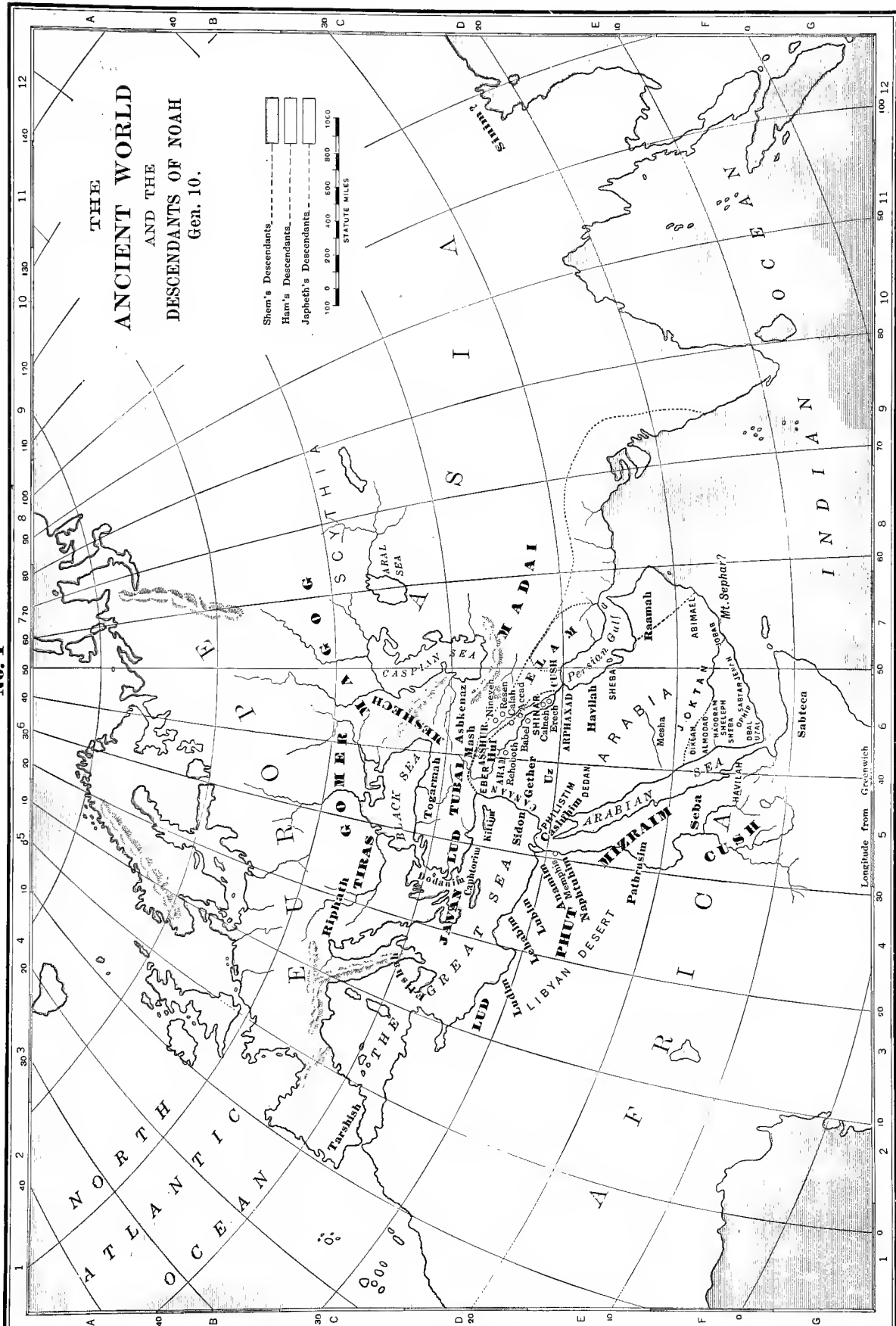

SINAI AND PALESTINE SHOWING ISRAEL'S JOURNEYS THROUGH THE DESERT

THE GREAT SEA (MEDITERRANEAN)

DESERT OF

ET-TIH (Paran)

MALEKITES

HOREB

Wilderness of Sinai

RED SEA

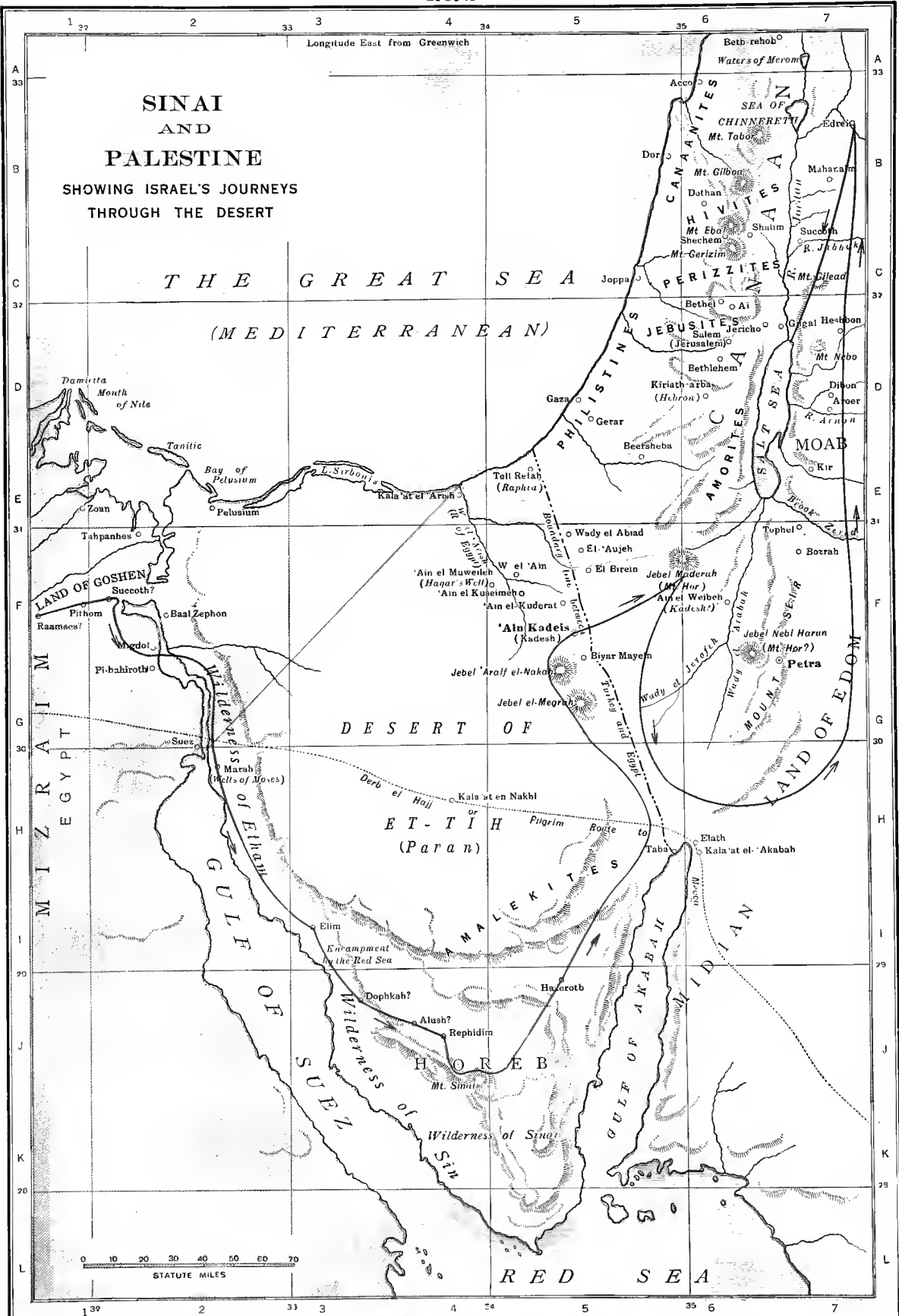



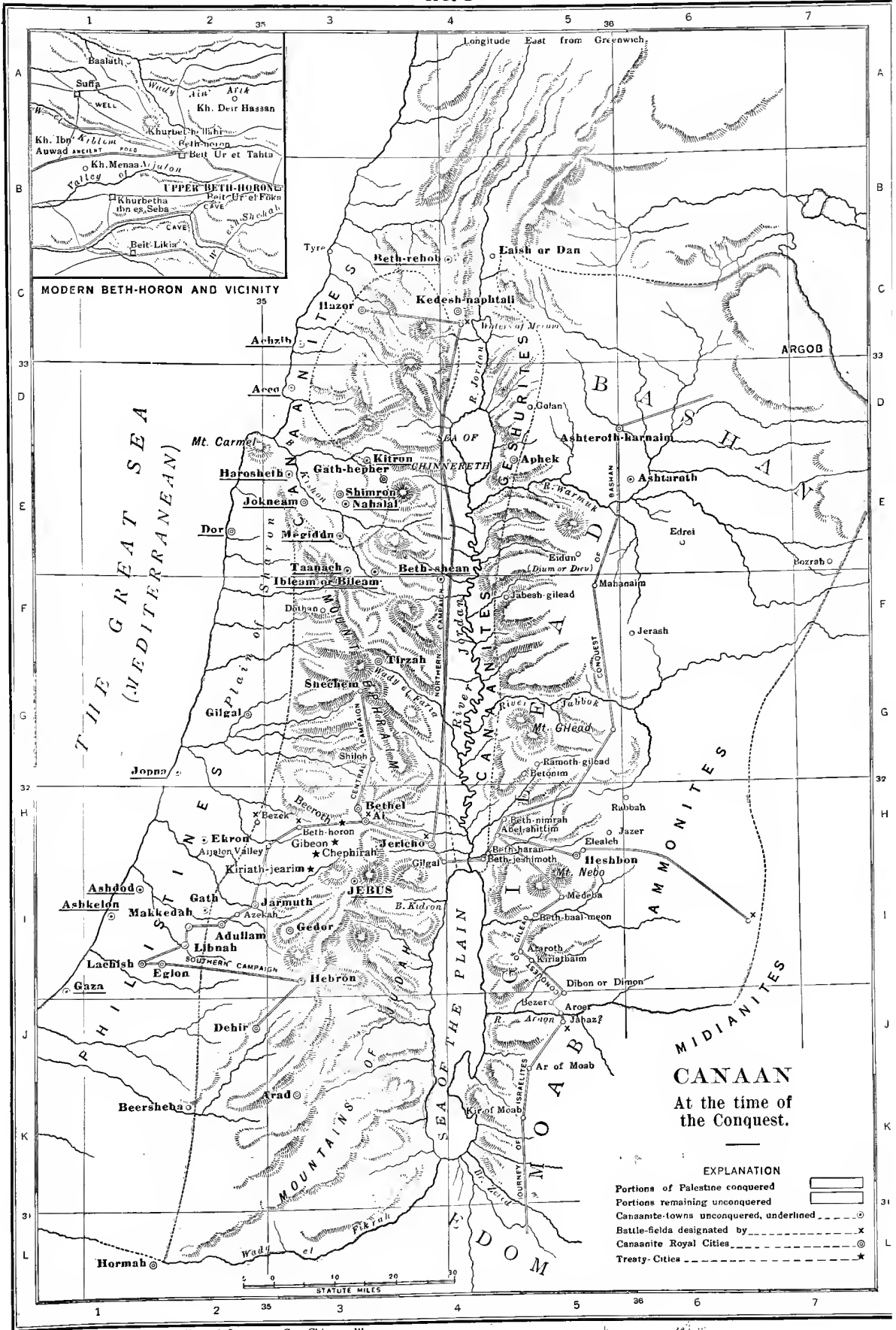



No. 5

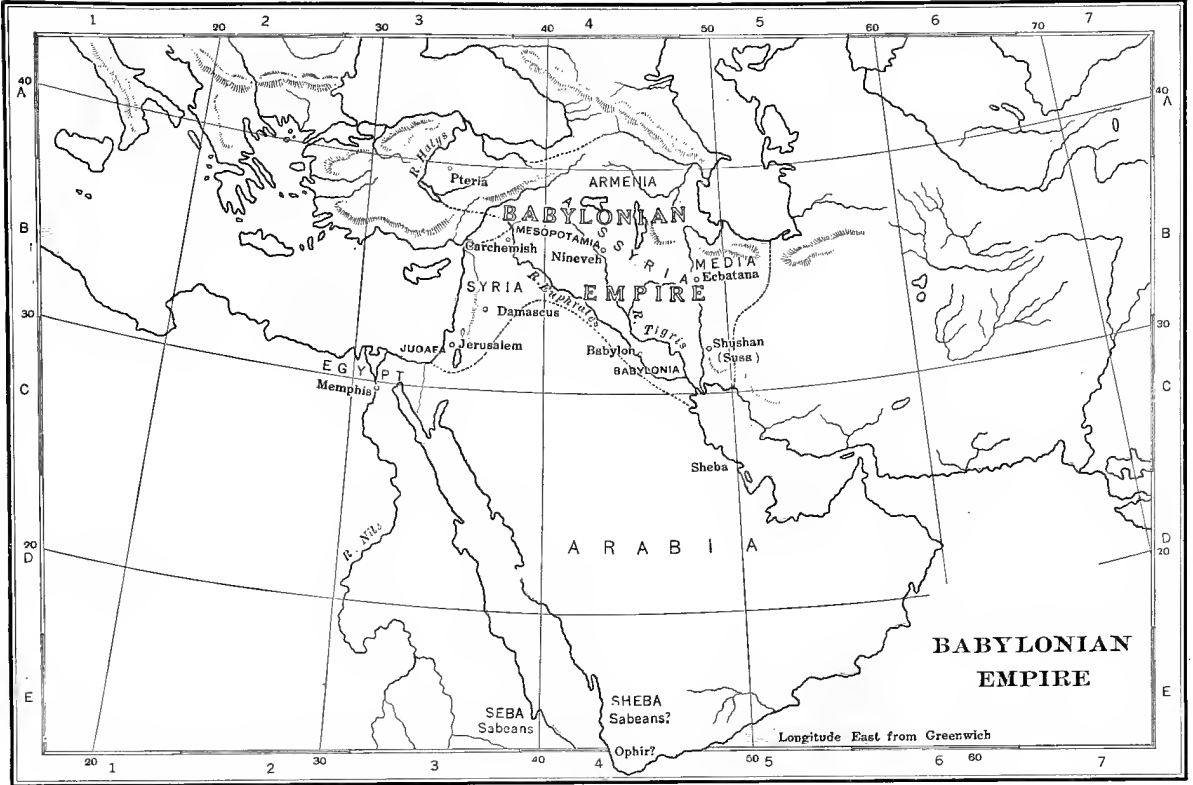

Copyright, 1915, by The Howard-Severance Co., Chicago, Ill.

No. 6

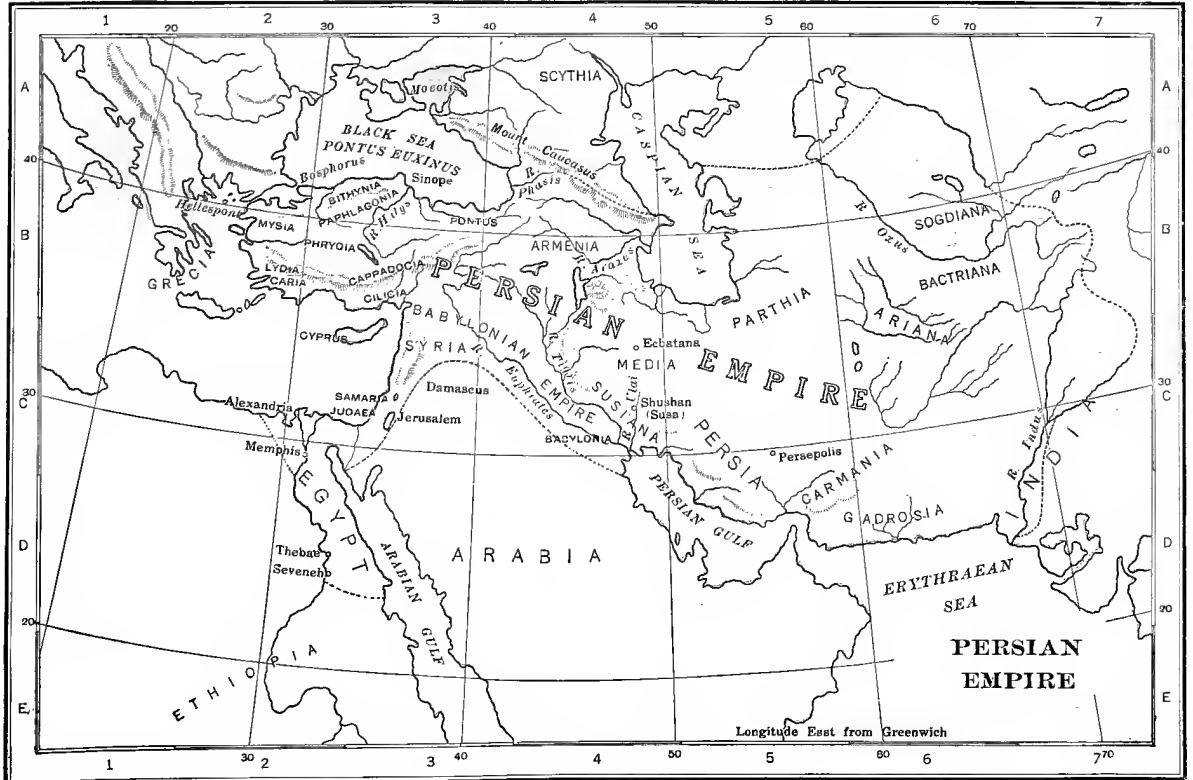

Copyright, 1915, by The Howard-Severance Co., Chicago, Ill.

No. 7



Copyright, 1915, by The Howard-Severance Co., Chicago, Ill.

No. 8

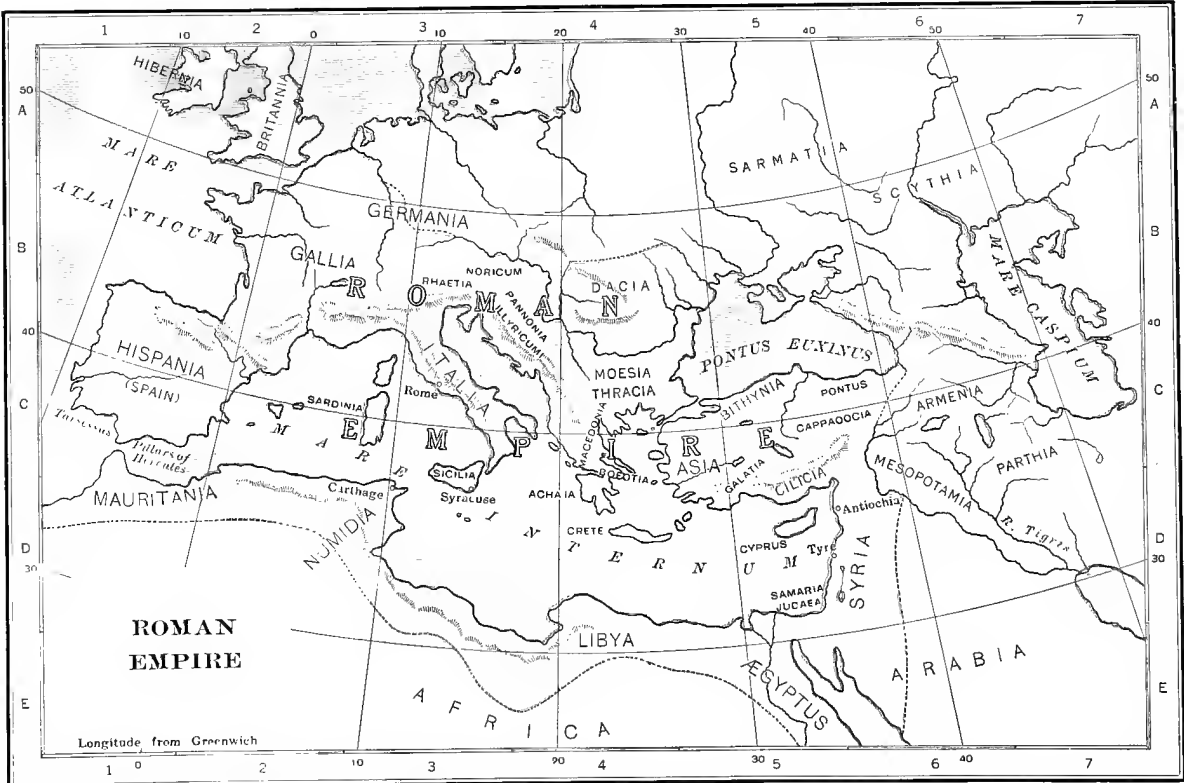

Copyright, 1915, by The Howard-Severance Co., Chicago, Ill.





# PALESTINE IN THE TIMES OF THE NEW TESTAMENT

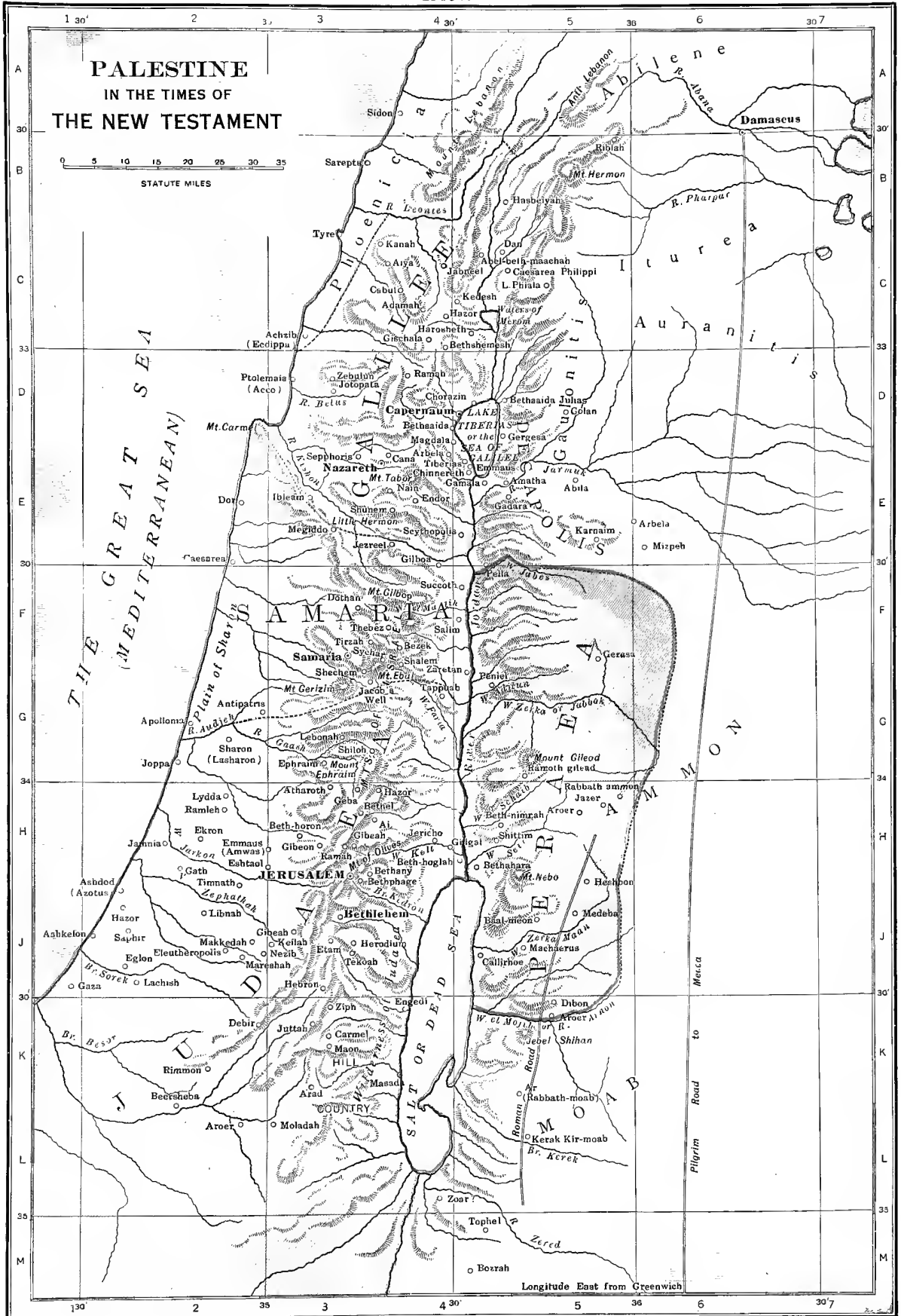
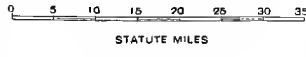

Longitude East from Greenwich

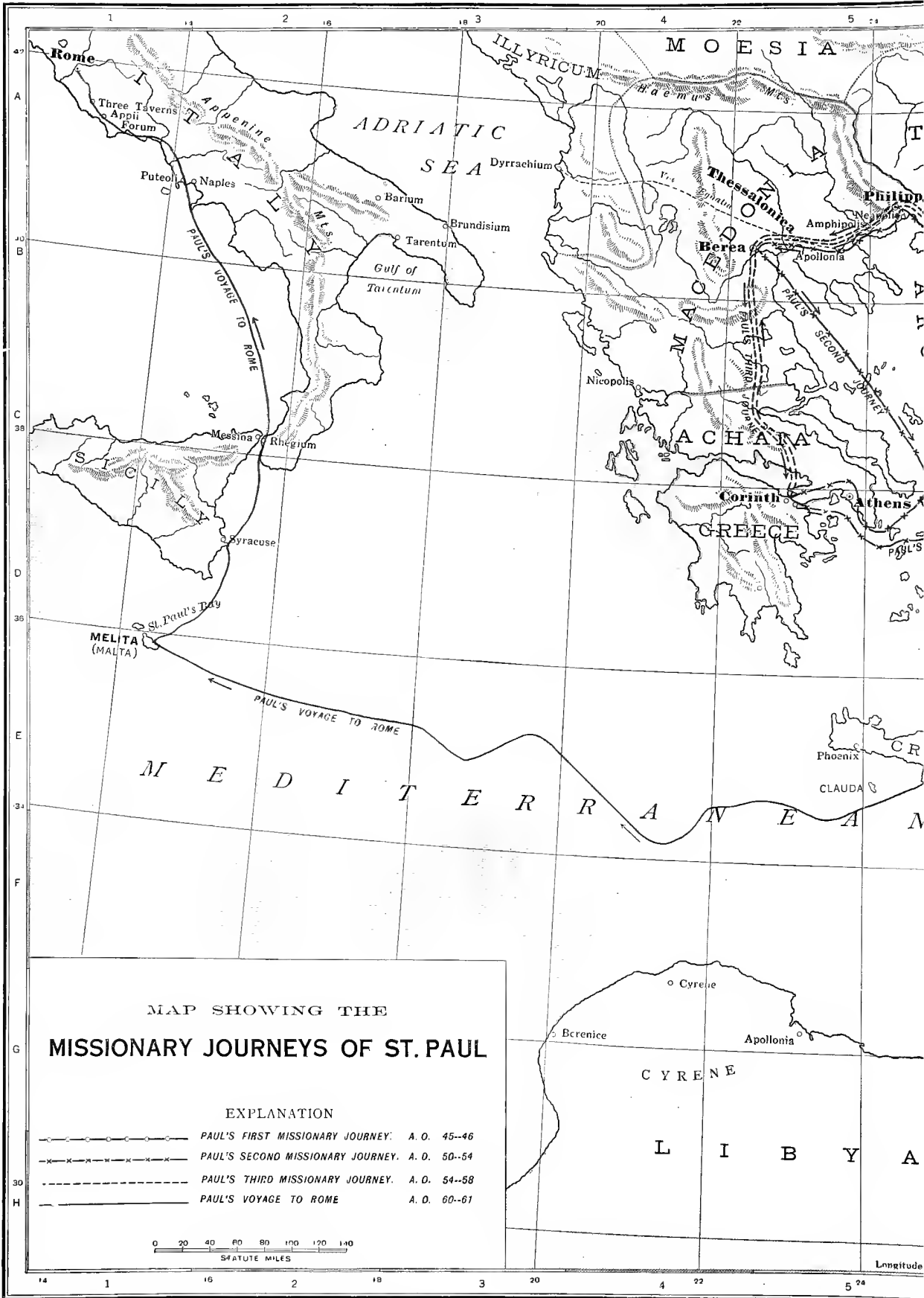





East from Greenwich

BUCKLEY CHICAGO 10

